

Report

Basic Assessment for the Proposed Development of a 9.9MW Internal Combustion Engine (ICE) associated with the Afrikaans PV Plant on the Remaining Extent of Farm Bokpoort 390, Groblershoop, Northern Cape

Revised Basic Assessment Report
DFFE Ref No. 14/12/16/3/3/1/2469

Client: ACWA Power Project DAO (RF) Pty Ltd

Reference: MD4195-ZZ-XX-R-YE-001

Status: 01/Draft

Date: 25 April 2022

ROYAL HASKONINGDHV (PTY) LTD

21 Woodlands Drive
Building 5
Country Club Estate
Woodmead
Johannesburg
2191
Mobility & Infrastructure
Reg No. 1966/001916/07

+27 87 352 1500 **T**
+27 11 798 6005 **F**
capetown@rhdhv.com **E**
royalhaskoningdhv.com **W**

Document title: Basic Assessment for the Proposed Development of a 9.9MW Internal Combustion Engine (ICE) associated with the Afrikaans PV Plant on the Remaining Extent of Farm Bokpoort 390, Groblershoop, Northern Cape
Document short title: BAR_9.9MW ICE
Reference: MD4195-ZZ-XX-R-YE-001
Status: 01/Draft
Date: 25 April 2022
Project name: MD4195
Project number: MD4195
Author(s): Seshni Govender & Prashika Reddy

Drafted by: Prashika Reddy (*Pr Sci Nat, EAPASA*)

Checked by: Malcolm Roods (*EAPASA*)

Date: 25.04.2022

Approved by: Malcolm Roods (*EAPASA*)

Date: 25.04.2022

Classification

Project related

Unless otherwise agreed with the Client, no part of this document may be reproduced or made public or used for any purpose other than that for which the document was produced. Royal HaskoningDHV (Pty) Ltd accepts no responsibility or liability whatsoever for this document other than towards the Client. Please note: this document contains personal data of employees of Royal HaskoningDHV (Pty) Ltd. Before publication or any other way of disclosing, this report needs to be anonymized.

Table of Contents

1	INTRODUCTION	1
1.1.1	Previous EIA Studies	4
1.1.2	Pre-application with Department of Forestry, Fisheries and the Environment (DFFE)	4
1.1.3	Basic Assessment Study	4
1.2	Structure of the Basic Assessment Report (BAR)	5
1.3	Specialist Assessments	9
1.4	Details of the Project Developer	9
1.5	Details of the Environmental Assessment Practitioner	9
2	PROJECT DESCRIPTION	11
2.1	Property Details	11
2.2	Project Location and Co-ordinates	11
2.3	Technical Description	11
2.3.1	Benefits of ICE in Renewable Projects	15
2.4	Need & Desirability	16
2.5	Socio-economic Value	22
3	ENVIRONMENTAL LEGISLATIVE CONTEXT	24
3.1	Other Relevant Acts, Guidelines, Department Policies and Environmental Management Instruments	26
3.2	International Conventions and Agreements	27
3.3	International Standards	29
3.3.1	International Finance Corporation Performance Standards	29
3.4	Equator Principles	33
3.4.1	The World Bank Group Environmental Health and Safety (EHS) Guidelines	33
3.5	Sustainable Development Goals	34
4	PROJECT ALTERNATIVES	35
4.1	Site Alternatives	35
4.2	Fuel Alternatives	35
4.3	No-Go Alternative	35
5	DESCRIPTION OF THE BASELINE ENVIRONMENT	36
5.1	Geology	36
5.2	Meteorological Conditions	37
5.2.1	Rainfall and Water Availability	37
5.2.2	Evaporation	39
5.2.3	Surface Wind Field	40

5.2.4	Temperature	42
5.3	Topography	43
5.4	Soils	44
5.5	Agricultural Capability	45
5.6	Surface Water	46
5.6.1	Water Quality	47
5.6.2	Surface Water Features at the Farm Bokpoort	48
5.7	Groundwater	48
5.7.1	Geology and Hydrogeological Setting	48
5.7.2	Hydrocensus	48
5.7.3	Groundwater Level and Flow	50
5.7.4	National Groundwater Archives and National Register of Water Use Databases	50
5.7.5	Groundwater Quality	50
5.7.6	Hydrogeological Characterisation	50
5.7.7	Groundwater Quality Compared to Water Criteria Guidelines/ Standards	51
5.8	Ecology	53
5.8.1	Alpha Diversity of the Study Area	53
5.8.2	Declared Invasive Species and Common Weeds	54
5.8.3	Plants with Traditional Medicinal Uses	54
5.8.4	Broad-Scale Habitat Types	55
5.8.5	Calcareous Low Shrub Plains	56
5.8.6	Open Shrub Duneveld	57
5.8.7	Open Shrub Plains	58
5.9	Faunal Attributes of the Study Area	59
5.9.1	Invertebrates	59
5.9.2	Amphibians	59
5.9.3	Reptiles	60
5.9.4	Mammals	60
5.9.5	Bats	60
5.10	Avifauna	61
5.10.1	Bird Microhabitats	61
5.10.2	Avifaunal Community	61
5.10.3	Avifaunal Sensitivity Zones	62
5.11	Air Quality	63
5.11.1	Existing Sources of Emissions	63
5.11.2	Air Quality Sensitive Receptors	64
5.11.3	Baseline Ambient Air Quality	64
5.12	Heritage	67
5.12.1	Stone Age	67
5.12.2	Iron Age	68
5.12.3	Historic period	68
5.13	Palaeontology	68
5.14	Traffic	69

5.14.1	Access to Site	69
5.14.2	Road Network and Intersections	69
5.14.3	Non-Motorized Transport	71
5.14.4	Accident Hotspots	71
5.14.5	Railway Lines	71
5.14.6	Proposed Refuse Sites	71
5.14.7	Haul Routes	71
5.14.8	Traffic Counts	72
5.14.9	Road Hierarchy	73
5.14.10	Public Transport Infrastructure	73
5.14.11	Dust	73
5.15	Visual	73
5.15.1	Landscape Physical Characteristics and Land Use	73
5.15.2	Visual Receptors	73
5.16	Noise Baseline	76
5.17	Socio-economic Baseline	78
5.17.1	Administrative Setting	78
5.17.2	Population Demographics	78
5.17.3	Levels of Education	79
5.17.4	Economic Activities	79
5.17.5	Employment Levels	81
6	PUBLIC PARTICIPATION PROCESS	82
6.1	Authority Consultation	83
6.2	Consultation with Other Relevant Stakeholders	83
6.3	Site Notification	83
6.4	Identification of Interested and Affected Parties	83
6.5	Background Notification	84
6.6	Advertising	84
6.7	Issues Trail	84
6.7.1	Public Review of the Revised Consultation BAR	84
6.8	Final BAR	84
7	IMPACT ASSESSMENT	85
7.1	Introduction	85
7.2	Impact Assessment Methodology	85
7.3	Potential Impacts and Significance	87
7.3.1	Geotechnical	87
7.3.2	Soils and Agricultural Potential	87
7.3.3	Hydrogeology	89
7.3.4	Surface Water	90
7.3.5	Ecology	91
7.3.6	Bats	94

7.3.7	Avifauna	95
7.3.8	Air Quality	98
7.3.9	Climate Change	115
7.3.10	Heritage	119
7.3.11	Palaeontology	120
7.3.12	Traffic	121
7.3.13	Visual	123
7.3.14	Noise	129
7.3.15	Socio-economic	134
7.4	Summary of Environmental Impacts	137
7.4.1	Construction Phase	137
7.4.2	Operations Phase	141
7.4.3	Closure and Rehabilitation	144
7.4.4	Cumulative	147
8	ENVIRONMENTAL AND CUMULATIVE IMPACT STATEMENT	149
8.1	Key Findings	149
8.1.1	Geotechnical	149
8.1.2	Soils and Agricultural Potential	149
8.1.3	Hydrogeology	149
8.1.4	Surface Water	149
8.1.5	Ecology	149
8.1.6	Avifauna	149
8.1.7	Air Quality	150
8.1.8	Climate Change	150
8.1.9	Heritage and Palaeontology	150
8.1.10	Traffic	151
8.1.11	Visual	151
8.1.12	Noise	151
8.1.13	Socio-economic	151
8.2	Environmental Impact Statement	152
8.3	Cumulative Impact Statement	152
8.4	Sensitivity Map	155
8.5	Assumptions, Uncertainties or Gaps in Knowledge	157
8.6	Recommendations	157
8.6.1	Recommendations to the CA	157
8.6.2	Recommendations to the Applicant	158
8.7	Declaration by the EAPs	158

Table of Tables

Table 1: Structure of the report.....	5
Table 2: Specialist assessments conducted for the project	9
Table 3: Applicant details	9
Table 4: EAP details	10
Table 5: Property details.....	11
Table 6: Project co-ordinates	11
Table 7: Technical details of the proposed ICE	15
Table 8: Project need, desirability and benefits.....	16
Table 9: Socio-economic details	22
Table 10: Key legislation considered.....	24
Table 11: Other relevant acts, guidelines, policies and environmental management instruments	26
Table 12: Relevant international conventions to which South Africa is a party	28
Table 13: IFC Performance Standards.....	29
Table 14: The classification of moisture availability climate classes for summer rainfall areas across South Africa.....	39
Table 15: Average monthly evaporation values for station D7E001.....	40
Table 16: Monthly temperature summary (2017 to 2019)	42
Table 17: Details of the 2017 Land Capability classification for South Africa	45
Table 18: Water quality in the Orange River at DWS monitoring points compared against the interim RWQOs.....	47
Table 19: Hydrocensus data collected during November 2019	49
Table 20: Livestock watering use compliance and risk status	51
Table 21: Drinking/ domestic use compliance and risk status	52
Table 22: List of common weeds and declared alien and invasive plant species within the study area.....	54
Table 23: List of traditional and medicinal uses within the study area	54
Table 24: Extent of habitat types within the study area	55
Table 25: Butterfly species of conservation concern recorded in the region of the study area	59
Table 26: Confirmed mammal taxa in the region	60
Table 27: Summary of the ambient measurements at DFFE Karoo AQMS for the period 2018 – 2020.....	65
Table 28: Overview of road network	69
Table 29: LOS classifications.....	70
Table 30: Overview of Gariep Road/ Transnet Service Road intersection	70

Table 31: Haul distance from Gauteng	71
Table 32: Traffic volumes 2016 (peak hour)	72
Table 33: Traffic volumes 2019 (peak hour)	72
Table 34: Road hierarchy.....	73
Table 35: Static sensitive receptor locations located within a 10 km radius of the proposed development site	74
Table 36: Rating levels.....	77
Table 37: Contribution to GVA (2010).....	79
Table 38: Criteria for the ranking of impacts.....	86
Table 39: Impact significance.....	86
Table 40: Simulated NO ₂ impact at the closest sensitive receptor for continuous operation of the generators during the 15-day reliability test	102
Table 41: Incremental life-time cancer risk at the closet receptor due to exposure to DPM	105
Table 42: Estimated cumulative impact of the project and existing baseline air pollutant concentrations.....	115
Table 43: Summary of Scope 1 estimated greenhouse gas emissions for the power station operation	117
Table 44: Existing and planned alternative energy generation facilities in the larger region	120
Table 45: Predicted unmitigated construction noise level and excess ambient noise levels	129
Table 46: Simulation of the existing noise levels from the proposed generators	131
Table 47: Simulation of noise levels from the proposed ICE	133
Table 48: Environmental impact assessment matrix for the construction phase	137
Table 49: Environmental impact assessment matrix for the operations phase.....	141
Table 50: Environmental impact assessment matrix for the closure and rehabilitation phase.....	144
Table 51: Summary of cumulative impacts	147
Table 52: Renewable energy projects within 30km of the proposed project	153

Table of Figures

Figure 1: Locality map	3
Figure 2: Example of a diesel engine flow chart	12
Figure 3: The four stages of combustion in a four-reciprocating engine	12
Figure 4: Example of a containerised ICE	13
Figure 5: Layout of a <i>Himoinisa</i> ICE	14

Figure 6: REDZ map.....	22
Figure 7: Sustainable Development Goals.....	34
Figure 8: Geology map	37
Figure 9: Monthly rainfall distribution for rainfall stations in the surrounding area	38
Figure 10: Annual rainfall recorded at the D7E001 (Boegoeberg Dam) station	38
Figure 11: Monthly mean, minimum and maximum evaporation for station D7E001 (Boegoeberg Dam).....	39
Figure 12: Period average, day-time and night-time wind roses (WRF simulated data; 2017 to 2019).....	41
Figure 13: Seasonal wind roses (WRF simulated data; 2017 to 2019).....	42
Figure 14: Monthly temperature profile (WRF simulated data, 2017 to 2019)	43
Figure 15: Terrain of the project area	44
Figure 16: Land types	45
Figure 17: Lower Orange Main Stem catchment area.....	46
Figure 18: Borehole locality map	49
Figure 19: Topography and groundwater head correlation	50
Figure 20: Piper diagram	51
Figure 21: Regional ecological types in spatial relation to the study area	53
Figure 22: Broad-scale habitat types of the study area.....	56
Figure 23: Locations of three Verreaux's Eagle and one Martial Eagle nests	63
Figure 24: Location of the project in relation to the AQSRs	64
Figure 25: Diurnal and seasonal variation plots of observed SO ₂ , NO ₂ , and CO at the DFFE Karoo AQMS (shaded area indicates 95th percentile confidence interval)	66
Figure 26: Diurnal and seasonal variation plots of observed PM _{2.5} and PM ₁₀ at the DFFE Karoo AQMS (shaded area indicates 95th percentile confidence interval)	67
Figure 27: Haul routes	72
Figure 28: Location of sensitive receptor locations within a 10km radius of the proposed development	75
Figure 29: Noise sensitive establishments	77
Figure 30: Percentage of agricultural households in each particular activity within the !Kheis LM	80
Figure 31: Steps in the public participation process.....	82
Figure 32: Simulated hourly average ambient SO ₂ concentrations.....	99
Figure 33: Simulated daily average ambient SO ₂ concentrations	100
Figure 34: Simulated annual average ambient SO ₂ concentrations	101
Figure 35: Simulated hourly NO ₂ concentrations	103
Figure 36: Simulated annual average ambient NO ₂ concentrations	104
Figure 37: Simulated daily average ambient PM ₁₀ concentrations.....	106

Figure 38: Simulated annual average ambient PM ₁₀ concentrations.....	107
Figure 39: Simulated daily average ambient PM _{2.5} concentrations	108
Figure 40: Simulated annual average ambient PM _{2.5} concentrations	109
Figure 41: Simulated excess life-time cancer risk due to exposure to DPM (based on annual PM _{2.5} concentrations	110
Figure 42: Simulated hourly average ambient CO concentrations.....	111
Figure 43: Simulated annual average ambient VOC concentrations.....	112
Figure 44: Simulated daily dustfall rates	114
Figure 45: Map indicating the location of alternative energy generation facilities in the larger region.....	120
Figure 46: Viewshed analysis undertaken as part of the original Visual Assessment for the Ndebele PV plant representative of the southern part of the development site	124
Figure 47: Viewshed analysis undertaken as part of the original Visual Assessment for the Zulu PV plant representative of the northern part of the development site	125
Figure 48: Predicted noise contour map for the construction phase.....	130
Figure 49: Predicted noise contour map for the operational phase.....	131
Figure 50: Predicted noise contour map of the cumulative operational phase of both proposed projects	133
Figure 51: Renewable energy projects within 30km of the proposed project.....	154
Figure 52: Sensitivity map.....	156

Photograph Log

Photograph 1: Example of calcareous low shrub plains.....	57
Photograph 2: Examples of open shrub duneveld habitat.....	58
Photograph 3: Examples of open shrub plains.....	58
Photograph 4: Some identified tools and flakes	68
Photograph 5: The Bokpoort farmstead viewed from the Sanddraai property to the west. Note the elevated position of the farmstead in relation to the surrounding terrain	125
Photograph 6: View in the direction of the development site from the raised portion of the Gariiep Road that crosses the Transnet Railway; neither the Bokpoort 1 Solar Plant or the proposed development area would be visible	126

Appendices

Appendix A: Maps and Layouts

Appendix B: DFFE Consultation and Approval of PP Plan

Appendix C: Specialist Studies

Appendix D: EAP CVs

Appendix E: Environmental Management Programme

Appendix F: Public Participation Report

Appendix G: Offset Feasibility Investigation (entire project)

Executive Summary

Background

In September 2020, the Department of Mineral Resources and Energy (DMRE) released a request for proposal as part of the Risk Mitigation Independent Power Producer Procurement Programme to reduce the current load shedding periods being experienced by the country. In responding to the request, ACWA Power Project DAO (RF) Pty Ltd (hereafter referred to as ACWA Power) submitted a bid for a 150MW (export capacity) PV plant that was bid as “Project DAO” and were successful. Project DAO has been classified as a Strategic Integrated Project (SIP) on the 01 April 2021 under Project Number: RM-TA-0025-001 in terms of Schedule 2 (Section 17(2)) of the Infrastructure Development Act (Act No. 23 of 2014).

A condition in the RFP requires Bidders to not tap into the national grid for power and requires that a reliability test for only 15 days be undertaken at a specified generation rate and time, once the Power Purchase Agreement has been finalised. PV can only generate electricity when the weather is favourable. In order to address this need, ACWA Power proposed additional infrastructure ICE within their authorised plants to create flexibility and efficiency within the plants for the reliability test period.

In meeting the RFP requirements, ACWA Power decided to supplement their already authorised project infrastructure by adding ICE infrastructure in the projects to be bid and were issued with Environmental Authorisations (EAs) in May 2021 for the following:

- Zulu ICE (Ref 14/12/16/3/3/1/2295);
- Venda ICE ((Ref 14/12/16/3/3/1/2296);
- Swati ICE ((Ref 14/12/16/3/3/1/2297);
- Sotho ICE (Ref 14/12/16/3/3/1/2298);
- Pedi ICE (Ref 14/12/16/3/3/1/2299);
- Ndebele ICE (Ref 14/12/16/3/3/1/2300); and
- Afrikaans ICE (Ref 14/12/16/3/3/1/2301).

The DMRE amended the reliability run requirements, and ACWA Power decided to lapse four (Zulu, Afrikaans, Sotho and Swati PV plant ICE) of the seven ICE EAs.

The DMRE has now confirmed that they are not amending the reliability run requirements, and as such, ACWA Power needs two additional ICE to meet these requirements. Individual applications for Environmental Authorisation will be lodged for the 9.9MW ICE within the Afrikaans and Sotho previously approved PV plants on the Bokpoort Farm, however, this Basic Assessment (BA) study is applicable to the entire development of the two individual ICE. The proposed positions of the ICE were planned taking into account the layout of other approved infrastructure e.g. PV plants and access routes, which will have to undergo an amendment process.

The draft consultation Basic Assessment Report (cBAR) was released for review and comment for a period of 30-days from 14 December 2021 to 04 February 2022, with Liquefied Petroleum Gas (LPG) or Liquefied Natural Gas (LNG) being one of the preferred fuel sources. Subsequent to the detailed engineering design, LPG/ LNG is no longer preferred to diesel, which has resulted in the update of the Atmospheric Impact Report (AIR). Therefore, this cBAR is being revised to reflect the preference for diesel, and an updated impact assessment reflecting this change.

The environmental team of Royal HaskoningDHV have been appointed as an Environmental Assessment Practitioner (EAP) by ACWA Power to undertake a Basic Assessment (BA) study for the project in terms of the Environmental Impact Assessment (EIA) Regulations 2014 (as amended), as promulgated under the National Environmental Management Act (NEMA) (Act No. 107 of 1998) (as amended).

Process

This Basic Assessment (BA) follows the legislative process prescribed in the Environmental Impact Assessment (EIA) Regulations 2014 (as amended). This report constitutes the revised cBAR which details the environmental outcomes, impacts and residual risks of the proposed activities. The report aims to assess the key environmental issues and impacts associated with the development, and to document Interested and Affected Parties' (I&APs) issues and concerns. Furthermore, it provides background information of the proposed project, a motivation and details of the proposed project, and describes the public participation undertaken to date.

In order to protect the environment and ensure that the development is undertaken in an environmentally responsible manner, there are a number of significant environmental legislation that were taken into consideration during this study and are elaborated on in this report.

The Department of Environment, Forestry and Fisheries (DFFE) is the lead/ Competent Authority for this BA study and the project needs to be authorised by this Department.

Key Findings**Geotechnical**

The fuel storage tanks associated with the ICE, would typically induce foundation pressures and the ICE exhaust stack would require support. Foundation pressure could be mitigated using conventional pad foundations. Piled foundations could be required for lattice stack structures.

Soils and Agricultural Potential

The proposed ICE will be developed on land which is of low agricultural potential and is not suitable for cultivation. No agriculturally sensitive areas occur within the proposed site and no part of it is therefore required to be set aside from the development. Because of the low agricultural potential of the site, and the consequent low agricultural impact, there are no restrictions relating to agriculture which would preclude authorisation of the proposed development.

Hydrogeology

The potential impacts associated with the development of the ICE will be primarily from spillage of fuels, lubricants and chemicals and will be of a low environmental significance provided that mitigation measures are implemented.

Surface Water

A Stormwater Management Plan (SWMP) must be implemented during the construction phase of the project. Spillage of fuels, lubricants and other chemicals must be cleaned up immediately and disposed of at an appropriately licenced landfill site. Mitigation for spillage or leakages must include bunded areas to store chemicals and/ or fuel.

Ecology

The proposed development will potentially affect biodiversity in three main ways: (i) loss in extent of vegetation communities and loss and associated disturbance of species of conservation concern during construction; (ii) effects on fauna species of conservation concern as a result of site lighting, security fencing and increased road traffic during operation, and (iii) the spread of invasive species and potential contamination of remaining natural (surrounding) ecosystems during closure. A review of the anticipated impacts associated with this type of development on the ecological environment indicates that none of the anticipated impacts can be highlighted or construed to represent an unacceptable or severe threat to sensitive biological or biodiversity components within the study area and wider region.

Avifauna

As the development footprint of the proposed ICEs fall entirely within the original development footprint assessed for the original Environmental Authorisations and the data collected for those impact assessments remain valid and sufficient to inform the assessment of the current proposed ICE additions.

Avian species particularly sensitive to disturbance would unlikely be in the vicinity of the ICEs due to the routine operational activities that would already be present on the site.

An increase in nesting opportunities on the ICE infrastructure would not likely attract target or priority species to the facility as these species generally avoid areas of human traffic and therefore the presence of ICEs will not increase the likelihood or significance rating of impacts associated with electrocutions or collisions beyond those already assessed. Mitigation measures have been recommended for inclusion the EMPr.

Air Quality

The main findings include the following:

- During the construction phase, impacts are likely to be localised and of short duration and a low rating was determined for the impact associated with the construction phase of the project.
- Compliance with hourly, daily, and annual NAAQS under normal operations is likely across the domain and at the receptors for SO₂, particulate matter, (PM₁₀ and PM_{2.5}), and carbon monoxide (CO).
- Hourly exceedances of the NO₂ NAAQ limit concentration is likely both on- and off-site, however, the total number of exceedances at the closest receptor is likely to be fewer than those allowed by the NAAQS. Simulated annual average NO₂ concentrations are lower than the NAAQS across the domain.
- Compliance with the chronic inhalation guidelines for volatile organic compounds (VOCs) and diesel particulate matter (DPM) are likely off-site.
- The excess cancer risk due to exposure to DPM was calculated to be low (on and near site) and very low at closest receptors and across the remainder of the domain.
- The United Nations Economic Commission for Europe (UNECE) Convention on Long Range Transboundary Air Pollution Limits) critical levels were used to assess the potential for impact of annual SO₂ and NO₂ concentrations on vegetation via various measures of productivity and reproductive success. Impacts to vegetative productivity are unlikely due to the project across in the domain or at any receptors.
- The impact of the facility was simulated to be below the NDCR. Mitigation measures for control vehicle entrainment dust emissions are recommended along the delivery route.
- A low rating was determined for the impact of criteria air pollutants associated with the normal operation of the project (2 hours per week).
- Cumulative impact of the project and the other sources in the area is likely to exceed the NAAQ limit concentration off site but not at the closest receptor and a low rating was determined for the mitigated impact of the project in isolation and in the context of other air pollution sources in the vicinity.

Climate Change

The annual CO₂-e emissions from the power station operations using diesel would, at maximum, contribute 0.037% to the South African “energy” sector total and represent a contribution of 0.004% to the National GHG inventory total (based on the published 2015 National GHG Inventory). However, it is noted here that the thermal power generation facilities are a backup to the renewable energy generated by the solar PV arrays and therefore the actual emissions are likely to be much lower than estimated on the assumed

operating hours. GHG emissions must be reported annually via the South African Greenhouse Gas Emission Reporting System.

Heritage and Palaeontology

Stone Age lithics dating to the MSA are found only as low-density surface scatters. The low density of the lithic scatters is, on archaeological grounds, viewed to be of low significance and require no further action. No sites, features or objects of cultural significance are known to exist in the development area, there would be no impact as a result of the proposed development. Should archaeological sites or graves be exposed in other areas during construction work, it must immediately be reported to a heritage practitioner so that an investigation and evaluation of the finds can be made.

No significant impacts on fossil heritage are anticipated during the construction, operational and closure phases of the project.

Traffic

Travel to and from the development site by personnel, deliveries and visitors will add to the existing traffic on the approach roads, affecting road safety, create dust from unpaved roads and road surface quality as experienced by existing road users during the construction phase.

It should be reiterated that the ICE will only be operated when the solar resources are not available in extreme weather conditions. The ICE will not have long periods of operating time, hence the load factors of the ICE shall be low. The delivery of diesel will be by road tanker with current capacity of 32T - 45T per load, current first fill to site storage is expected with monthly top-up fills planned as required. Fuel to be transferred on site will be through a purpose build fuel offloading facility and stored in on-site storage tanks. The fuel storage system will be able to handle fuel for at least three consecutive days of full operation.

Visual

The addition of the ICE is not expected to significantly alter the area of potential visual exposure and is therefore not expected to significantly alter the influence of the Solar Energy Facility (SEF) on areas of higher viewer incidence (observers traveling along the national, arterial/ main, or major secondary roads within the region) or potential sensitive visual receptors (residents of homesteads in close proximity to the SEF).

In consideration of the proposed addition of the ICE, there is no (zero) change to the significance rating compared with the original Visual Impact Assessment Report, and no additional visual impacts are envisaged.

Noise

The assessment outcome indicated that noise mitigation is required during the construction and operational phases. Key mitigation options include:

- Construction Phase - The most important mitigation option is to ensure the construction occurs during day-time hours.
- Mitigation requires engineering input from a qualified acoustic consultant. Further to this, an annual noise measurement programme is recommended.

With mitigation measures implemented, the proposed two 9.9MW ICE would comply with the Noise Control Regulations (GN R.154 of 1992). The project does not present a fatal flaw in terms of noise assessment. The project should be authorised in terms of noise, with mitigation measures adhered to.

Socio-economic

The proposed project will have a positive impact as this will provide further support to the national grid, therefore providing electricity security to the region and the country. The potential job creation during the project's construction phase will be a positive for the local and regional economy as unemployment in the country is increasing. An assured and diversified electricity generation mix is a key step in attracting investors into South Africa and is key for the growth and development.

Recommendations

This revised consultation BAR provides an assessment of both the benefits and potential negative impacts anticipated as a result of the proposed project. The preferred fuel alternative would be diesel. Having duly considered the project, in the Environmental Assessment Practitioner's (EAP's) opinion, the project does not pose a detrimental impact on the receiving environment and its inhabitants and can be mitigated significantly. From a cumulative impact perspective, the proposed project will be developed within a REDZ (REDZ 7) which is earmarked for large scale solar energy facilities and is within the Northern Corridor Strategic Transmission Corridor. Further to this, the development is preferable, from an impact point of view as well as from practical considerations, to rather have a concentrated node of renewable energy development within one area, than to spread out the same number of developments over a larger area.

Note: Key changes to the draft consultation cBAR are underlined for ease of reference in this revised cBAR.

Acronyms

AEL	Atmospheric Emissions Licence
AQMS	Air Quality Monitoring Station
AQSR	Air Quality Sensitive Receptor
BA	Basic Assessment
BAR	Basic Assessment Report
BESS	Battery Energy Storage System
CA	Competent Authority
CBA	Critical Biodiversity Area
CBAR	Consultation Basic Assessment Report
CSP	Concentrating Solar Power
CV	Curriculum Vitae
DFFE	Department of Forestry, Fisheries and the Environment
DMRE	Department of Mineral Resources and Energy
DPM	Diesel Particulate Matter
DWS	Department of Water and Sanitation
EA	Environmental Authorisation
EAP	Environmental Assessment Practitioner
EAPASA	Environmental Assessment Practitioner Association of South Africa
ECO	Environmental Control Officer
EHS	Environmental, Health and Safety
EIA	Environmental Impact Assessment
EMPr	Environmental Management Programme
EP	Equator Principles
EPFI	Equator Principles Financial Institutions
EWT	Endangered Wildlife Trust
GA	General Authorisation
GHG	Greenhouse Gas
GIS	Geographic Information System
GNR	Government Notice Regulation
I&AP	Interested and Affected Party
ICE	Internal Combustion Engine
IFC	International Finance Corporation
IDP	Integrated Development Plan
IPP	Independent Power Producer
IRP	Integrated Resources Plan
IEM	Integrated Environmental Management
LNG	Liquefied Natural Gas
LPG	Liquefied Petroleum Gas
LOS	Level of Service
MW	Megawatt
NAAQS	National Ambient Air Quality Standards
NCDENC	Northern Cape Department of Environment and Nature Conservation
NEMA	National Environmental Management Act (Act No. 107 of 1998)
NEM:AQA	National Environmental Management Air Quality Act (Act No. 39 of 2004)
NEM:BA	National Environmental Management Biodiversity Act (Act No. 10 of 2004)
NEM:PAA	National Environmental Management Protected Areas Act (Act No. 57 of 2003)

NEM:WA	National Environmental Management – Waste Act (Act No. 59 of 2008)
NFA	National Forests Act (Act No. 84 of 1998)
NGO	Non-Governmental Organisation
NHRA	National Heritage Resources Act (Act No. 25 of 1999)
NWA	National Water Act (Act No. 36 of 1998)
OHSA	Occupational Health and Safety Act (Act No 85 of 1993)
PES	Present Ecological State
PP	Public Participation
PPA	Power Purchase Agreement
PS	Performance Standards
PV	Photovoltaic
REC	Recommended Ecological Category
REDZ	Renewable Energy Development Zone
RFP	Request for Proposal
RMIPPP	Risk Mitigation Independent Power Producer Procurement Programme
SAAQIS	South African Air Quality Information System
SACNASP	South African Council of Natural Science Professionals
SDG	Sustainable Development Goals
SEF	Solar Energy Facility
SIP	Strategic Integrated Project
SWMP	Stormwater Management Plan
UNFCC	United Nations Framework Convention on Climate Change
WRF	Weather Research and Forecasting
WUA	Water Use Authorisation

Symbols

CH ₄	Methane
CO	Carbon monoxide
CO ₂	Carbon dioxide
CO ₂ -eq	Carbon dioxide equivalent
NO	Nitrogen oxide
N ₂ O	Nitrous oxide
NO ₂	Nitrogen dioxide
NO _x	Oxides of nitrogen
O ₃	Ozone
PM _{2.5}	Inhalable particulate matter (aerodynamic diameter less than 2.5 µm)
PM ₁₀	Thoracic particulate matter (aerodynamic diameter less than 10µm)
SO ₂	Sulfur dioxide
tpa	Tonnes per annum

Glossary

Activity (Development)	An action either planned or existing that may result in environmental impacts through pollution or resource use. For the purpose of this report, the terms 'activity' and 'development' are freely interchanged.
Alternatives	Different means of meeting the general purpose and requirements of the activity, which may include site or location alternatives; alternatives to the type of activity being undertaken; the design or layout of the activity; the technology to be used in the activity and the operational aspects of the activity.
Applicant	The project proponent or developer responsible for submitting an environmental application to the relevant environmental authority for environmental authorisation.
Biodiversity	The diversity of animals, plants and other organisms found within and between ecosystems, habitats, and the ecological complexes.
Buffer	A buffer is seen as an area that protects adjacent communities from unfavourable conditions. A buffer is usually an artificially imposed zone included in a management plan.
Construction	The building, erection or establishment of a facility, structure or infrastructure that is necessary for the undertaking of a listed or specified activity but excludes any modification, alteration or expansion of such a facility, structure or infrastructure and excluding the reconstruction of the same facility in the same location, with the same capacity and footprint.
Cumulative Impact	The impact of an activity that in itself may not be significant but may become significant when added to the existing and potential impacts eventuating from similar or diverse activities or undertakings in the area.
Decommissioning	The demolition of a building, facility, structure or infrastructure.
Direct Impact	Impacts that are caused directly by the activity and generally occur at the same time and at the same place of the activity. These impacts are usually associated with the construction, operation or maintenance of an activity and are generally quantifiable.
Ecosystem	A dynamic system of plant, animal (including humans) and micro-organism communities and their non-living physical environment interacting as a functional unit. The basic structural unit of the biosphere, ecosystems are characterised by interdependent interaction between the component species and their physical surroundings. Each ecosystem occupies a space in which macro-scale conditions and interactions are relatively homogenous.
Environment	In terms of the National Environmental Management Act (NEMA) (Act No 107 of 1998) (as amended), "Environment" means the surroundings within which humans exist and that are made up of: <ul style="list-style-type: none"> i. the land, water and atmosphere of the earth; ii. micro-organisms, plants and animal life; iii. any part or combination of (i) and (ii), and the interrelationships among and between them; and iv. the physical, chemical, aesthetic and cultural properties and conditions of the foregoing that influence human health and wellbeing.
Environmental Assessment	The generic term for all forms of environmental assessment for projects, plans, programmes or policies and includes methodologies or tools such as environmental impact assessments, strategic environmental assessments and risk assessments.

Environmental Authorisation	An authorisation issued by the competent authority in respect of a listed activity, or an activity which takes place within a sensitive environment.
Environmental Assessment Practitioner (EAP)	The individual responsible for planning, management and coordination of environmental impact assessments, strategic environmental assessments, environmental management programmes or any other appropriate environmental instrument introduced through the EIA Regulations.
Environmental Control Officer (ECO)	An individual nominated through the Client to be present on site to act on behalf of the Client in matters concerning the implementation and day to day monitoring of the EMPr and conditions stipulated by the authorities.
Environmental Impact	Change to the environment (biophysical, social and/ or economic), whether adverse or beneficial, wholly or partially, resulting from an organisation's activities, products or services.
Environmental Management	Ensuring that environmental concerns are included in all stages of development, so that development is sustainable and does not exceed the carrying capacity of the environment.
Environmental Management Programme (EMPr)	A detailed plan of action prepared to ensure that recommendations for enhancing or ensuring positive impacts and limiting or preventing negative environmental impacts are implemented during the life cycle of a project.
Fatal Flaw	An event or condition that could cause an unanticipated problem and/or conflict which could result in a development being rejected or stopped.
Groundwater	Water in the ground that is in the zone of saturation from which wells, springs, and groundwater runoff are supplied.
Hazardous Waste	Any waste that contains organic or inorganic elements or compounds that may, owing to the inherent physical, chemical or toxicological characteristics of that waste, have a detrimental impact on health and the environment and includes hazardous substances, materials or objects within business waste, residue deposits and residue stockpiles as outlined in the National Environmental Management: Waste Amendment Act (No 26 of 2014).Schedule 3: Category A – Hazardous Waste.
Hydrology	The science encompassing the behaviour of water as it occurs in the atmosphere, on the surface of the ground, and underground.
Indirect Impacts	Indirect or induced changes that may occur as a result of the activity. These types if impacts include all of the potential impacts that do not manifest immediately when the activity is undertaken or which occur at a different place as a result of the activity
Integrated Environmental Management	A philosophy that prescribes a code of practice for ensuring that environmental considerations are fully integrated into all stages of the development and decision-making process. The IEM philosophy (and principles) is interpreted as applying to the planning, assessment, implementation and management of any proposal (project, plan, programme or policy) or activity - at local, national and international level – that has a potentially significant effect on the environment. Implementation of this philosophy relies on the selection and application of appropriate tools for a particular proposal or activity. These may include environmental assessment tools (such as strategic environmental assessment and risk assessment), environmental management tools (such as monitoring, auditing and reporting) and decision-making tools (such as multi-criteria decision support systems or advisory councils).
Interested and Affected Party (I&AP)	Any person, group of persons or organisation interested in or affected by an activity; and any organ of state that may have jurisdiction over any aspect of the activity.

Method Statement	A method statement is a written submission by the Contractor to the Engineer in response to the specification or a request by the Engineer, setting out the plant, materials, labour and method the Contractor proposes using to carry out an activity, identified by the relevant specification or the Engineer when requesting a Method Statement. It contains sufficient detail to enable the Engineer to assess whether the Contractor's proposal is in accordance with the Specifications and/or will produce results in accordance with the Specifications.
Mitigate	The implementation of practical measures designed to avoid, reduce or remedy adverse impacts or enhance beneficial impacts of an action.
No-Go Option	In this instance the proposed activity would not take place, and the resulting environmental effects from taking no action are compared with the effects of permitting the proposed activity to go forward.
Pollution	The National Environmental Management Act, No. 107 of 1998 defines pollution to mean any change in the environment caused by – substances; radioactive or other waves; or noise, odours, dust or heat emitted from any activity, including the storage or treatment of waste or substances, construction and the provision of services, whether engaged in by any person or an organ of state, where that change has an adverse effect on human health or well-being or on the composition, resilience and productivity of natural or managed ecosystems, or on materials useful to people, or will have such an effect in the future.
Public Participation Process	A process in which potential interested and affected parties are given an opportunity to comment on, or raise issues relevant to, specific matters.
Re-use	To utilise articles from the waste stream again for a similar or a different purpose without changing the form of properties of the articles.
Rehabilitation	A measure aimed at reinstating an ecosystem to its original function and state (or as close as possible to its original function and state) following activities that have disrupted those functions.
Sensitive Environments	Any environment identified as being sensitive to the impacts of the development.
Significance	Significance can be differentiated into impact magnitude and impact significance. Impact magnitude is the measurable change (i.e. magnitude, intensity, duration and likelihood). Impact significance is the value placed on the change by different affected parties (i.e. level of significance and acceptability). It is an anthropocentric concept, which makes use of value judgements and science-based criteria (i.e. biophysical, social and economic).
Stakeholder Engagement	The process of engagement between stakeholders (the proponent, authorities and I&APs) during the planning, assessment, implementation and/or management of proposals or activities.
Sustainable Development	Development which meets the needs of current generations without hindering future generations from meeting their own needs.
Visual Contrast	The degree to which the development would be congruent with the surrounding environment. It is based on whether or not the development would conform with the land use, settlement density, forms and patterns of elements that define the structure of the surrounding landscape.
Watercourse	Defined as: <ul style="list-style-type: none"> i. a river or spring; ii. a natural channel or depression in which water flows regularly or intermittently; iii. a wetland, lake or dam into which, or from which, water flows; and

- iv. any collection of water which the Minister may, by notice in the Gazette, declare to be a watercourse as defined in the National Water Act, 1998 (Act No. 36 of 1998) and a reference to a watercourse includes, where relevant, its bed and banks.

Water Pollution

The National Water Act, 36 of 1998 defined water pollution to be the direct or indirect alteration of the physical, chemical or biological properties of a water resource so as to make it – less fit for any beneficial purpose for which it may reasonably be expected to be used; or harmful or potentially harmful (aa) to the welfare, health or safety of human beings; (bb) to any aquatic or non-aquatic organisms; (cc) to the resource quality; or (dd) to property”.

Wetland

Land which is transitional between terrestrial and aquatic systems where the water table is usually at or near the surface, or the land is periodically covered with shallow water, and which land in normal circumstances supports or would support vegetation typically adapted to life in saturated soil.

1 INTRODUCTION

In September 2020, the Department of Mineral Resources and Energy (DMRE) released a request for proposal as part of the Risk Mitigation Independent Power Producer Procurement Programme to reduce the current load shedding periods being experienced by the country. In responding to the request, ACWA Power Project DAO (RF) Pty Ltd (hereafter referred to as ACWA Power) submitted a bid for a 150MW (export capacity) PV plant that was bid as “Project DAO” and were successful. Project DAO has been classified as a Strategic Integrated Project (SIP) on the 01 April 2021 under Project Number: RM-TA-0025-001 in terms of Schedule 2 (Section 17(2)) of the Infrastructure Development Act (Act No. 23 of 2014).

A condition in the RFP requires Bidders to not tap into the national grid for power and requires that a reliability test for only 15 days be undertaken at a specified generation rate and time, once the Power Purchase Agreement has been finalised. PV can only generate electricity when the weather is favourable. In order to address this need, ACWA Power proposed additional infrastructure ICE within their authorised plants to create flexibility and efficiency within the plants for the reliability test period.

In meeting the RFP requirements, ACWA Power decided to supplement their already authorised project infrastructure by adding ICE infrastructure in the projects to be bid and were issued with Environmental Authorisations (EAs) in May 2021 for the following:

- Zulu ICE (Ref 14/12/16/3/3/1/2295);
- Venda ICE ((Ref 14/12/16/3/3/1/2296);
- Swati ICE ((Ref 14/12/16/3/3/1/2297);
- Sotho ICE (Ref 14/12/16/3/3/1/2298);
- Pedi ICE (Ref 14/12/16/3/3/1/2299);
- Ndebele ICE (Ref 14/12/16/3/3/1/2300); and
- Afrikaans ICE (Ref 14/12/16/3/3/1/2301).

The DMRE amended the reliability run requirements, and ACWA Power decided to lapse four (Zulu, Afrikaans, Sotho and Swati PV plant ICE) of the seven ICE EAs.

The DMRE has now confirmed that they are not amending the reliability run requirements, and as such, ACWA Power needs two additional ICE to meet these requirements. Individual applications for Environmental Authorisation will be lodged for the 9.9MW ICE within the Afrikaans and Sotho previously approved PV plants on the Bokpoort Farm, however, this Basic Assessment (BA) study is applicable to the entire development of the two individual ICE. The proposed positions of the ICE were planned taking into account the layout of other approved infrastructure e.g. PV plants and access routes, which will have to undergo an amendment process.

The environmental team of Royal HaskoningDHV have been appointed as an Environmental Assessment Practitioner (EAP) by ACWA Power to undertake a Basic Assessment (BA) study for the project in terms of the Environmental Impact Assessment (EIA) Regulations 2014 (as amended), as promulgated under the National Environmental Management Act (NEMA) (Act No. 107 of 1998) (as amended).

The draft consultation Basic Assessment Report (cBAR) was released for review and comment for a period of 30-days from 14 December 2021 to 04 February 2022, with Liquefied Petroleum Gas (LPG) or Liquefied Natural Gas (LNG) being one of the preferred fuel sources. Subsequent to the detailed engineering design, LPG/ LNG is no longer preferred to diesel, which has resulted in the update of the Atmospheric Impact Report (AIR). Therefore, this cBAR is being revised to reflect the preference for diesel, and an updated impact assessment reflecting this change.



ACWA Power has indicated that the development will be funded from local and international sources and hence the environmental studies for the proposed development would need to comply with the International Finance Corporation Performance Standards (IFC) 2012 and the Equator Principles.

The locality map including the layout of the ICE is provided in Figure 1 and **Appendix A**.

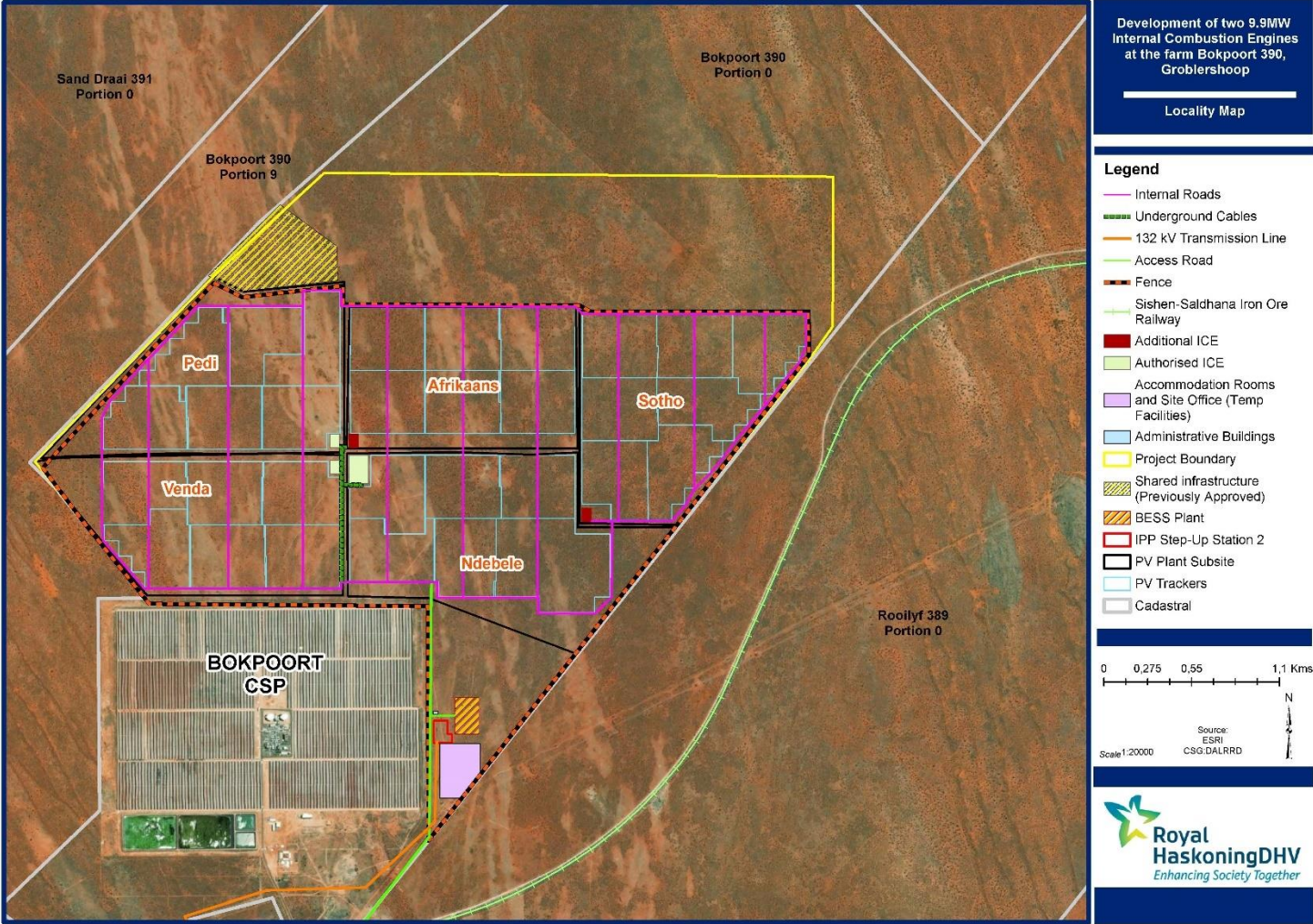

Figure 1: Locality map

1.1.1 Previous EIA Studies

This BA study relies on the previous EIA studies including specialist assessments listed below:

- Proposed 75MW Concentrating Solar Thermal Power Plant and Associated Infrastructure in the Siyanda District, Northern undertaken by Bohlweki SSI Environmental, 2011¹.
- Proposed 150MW CSP Tower Development on the Remaining Extent of the Farm Bokpoort 390, Northern Cape undertaken by Golder Associates Africa, 2016².
- Proposed 75MW Photovoltaic (PV 1) Solar Development on the Remaining Extent of the Farm Bokpoort 390, Northern Cape undertaken by Golder Associates Africa, 2016³.
- Proposed 75MW Photovoltaic (PV 2) Solar Development on the Remaining Extent of the Farm Bokpoort 390, Northern Cape undertaken by Golder Associates Africa, 2016⁴.
- Basic Assessment for the Proposed Development of Seven 9.9MW Internal Combustion Engines (ICE) on the Remaining Extent of Farm Bokpoort 390, Groblershoop, Northern Cape⁵

1.1.2 Pre-application with Department of Forestry, Fisheries and the Environment (DFFE)

No pre-application meeting was held with the DFFE as the Case Officer indicated *via* email (22 October 2021) that it is the choice of the Applicant or EAP to request a pre-application meeting. Clarity was obtained *via* email, where it was indicated that (**Appendix B**):

- If the proposed development will trigger Listing Notice 1 and Listing Notice 3 activities, a BA process would be required. In addition, if the proposed development triggers Listing Notice 2 activities a full Scoping and Environmental Impact Assessment process would be required. However, it remains the task of Applicant and their environmental assessment practitioners (EAPs) to ascertain which listed activities are triggered in terms of Listing Notices 1, 2 and 3.
- The Public Participation (PP) plan will be reviewed and considered by the Department – the PP plan was approved on 04 November 2021 (**Appendix B**).

1.1.3 Basic Assessment Study

A Basic Assessment (BA) is the level of environmental assessment applicable to activities listed in Listing Notices 1 and 3. A BA is applied to activities that are considered less likely to have significant environmental impacts and, therefore, unlikely to require a detailed Environmental Impact Assessment (EIA).

The BA aims to achieve the following:

- Determine the policy and legislative context within which the proposed activity is undertaken and how the activity complies with and responds to the policy and legislative context;
- Describe the need and desirability of the proposed project;
- Identify the alternatives considered, including the activity, location, and technology alternatives;
- Undertake an impact and risk assessment process inclusive of reasonably foreseeable cumulative impacts (where applicable). The focus being determining the geographical, physical, biological, social, economic, heritage and cultural sensitivity of the project and the risk of impact of the

¹ Benedek, F; Roods, M. 2011. *Environmental Impact Assessment for a Proposed 75MW Concentrating Solar Thermal Power Plant and Associated Infrastructure in the Siyanda District, Northern Cape*. Bohlweki SSI Environmental. DEA Reference number: 12/12/20/1920.

² Schlechter, M., & Baxter, B. 2016. *Final EIA Report: Proposed 150MW CSP Tower Development on the Remaining Extent of Farm Bokpoort 390, Northern Cape*. Golder Associates. Ref 14/12/16/3/3/2/879.

³ Schlechter, M., & Baxter, B. 2016. *Final EIA Report: Proposed 75MW Photovoltaic (PV1) Solar Development on the Remaining Extent of the Farm Bokpoort 390, Northern Cape*. Golder Associates. Ref 14/12/16/3/3/2/881.

⁴ Schlechter, M., & Baxter, B. 2016. *Final EIA Report: Proposed 75MW Photovoltaic (PV2) Solar Development on the Remaining Extent of the Farm Bokpoort 390, Northern Cape*. Golder Associates. Ref 14/12/16/3/3/2/880.

⁵ Royal HaskoningDHV. 2021. *Final Basic Assessment for the Proposed Development of Seven 9.9MW Internal Combustion Engines (ICE) on the Remaining Extent of Farm Bokpoort 390, Groblershoop, Northern Cape*

proposed activity on these aspects to determine the nature, significance, consequence, extent, duration, and probability of the impacts occurring to; and the degree to which these impacts:

- can be reversed;
- may cause irreplaceable loss of resources; and
- can be avoided, managed or mitigated.

This revised BAR has been compiled in accordance with the stipulated requirements in GNR 326, Appendix 1 of the EIA Regulations, 2014 (as amended), which outlines the legislative BA process and requirements for assessment of outcomes, impacts and residual risks of the proposed development. The BAR further incorporates the findings and recommendations of the specialist studies conducted for the project.

An Environmental Management Programme (EMPr) has been compiled according to Appendix 4 of GNR 326 of the EIA Regulations, 2014 (as amended) for the construction and operational phases of the project.

The EMPr provides the actions for the management of identified environmental impacts emanating from the project and a detailed outline of the implementation programme to minimise and/ or eliminate any anticipated negative environmental impacts and to enhance positive impacts. The EMPr provides strategies to be used to address the roles and responsibilities of environmental management personnel on site, and a framework for environmental compliance and monitoring.

1.2 Structure of the Basic Assessment Report (BAR)

The revised BAR is structured as follows:

Table 1: Structure of the report

Appendix 1: Content of Basic Assessment Reports	Chapter/ Section
(a) details of <ul style="list-style-type: none"> i) the EAP who prepared the report; and ii) the expertise of the EAP to carry out an environmental impact assessment 	Section 1.5
(b) The location of the activity (21-digit Surveyor General code, physical address and farm name where available, coordinates of the boundary of the property)	Section 2.1 & 2.2
(c) A plan which locates the proposed activity or activities applied for as well as associated structures and infrastructure at an appropriate scale or, if it is – a linear activity, a description of the route of the activity.	Figure 1
(d) A description of the scope of the proposed activity, including – <ul style="list-style-type: none"> i) all listed and specified activities triggered and being applied for; and ii) a description of the activities to be undertaken including associated structures and infrastructure. 	Chapter 2 & 3
(e) A description of the policy and legislative context within which the development is proposed including – <ul style="list-style-type: none"> i) an identification of all legislation, policies, plans, guidelines, spatial tools, municipal development planning frameworks, and instruments that are applicable to this activity and have been considered in the preparation of the report; and 	Chapter 3

Appendix 1: Content of Basic Assessment Reports	Chapter/ Section
ii) how the proposed activity complies with and responds to the legislation and policy context, plans, guidelines, tools frameworks, and instruments.	
(f) A motivation for the need and desirability for the proposed development including the need and desirability of the activity in the context of the preferred location.	Section 2.4
(g) A motivation for the preferred site, activity and technology alternative.	Chapter 4
(h) A full description of the process followed to reach the proposed preferred alternative within the site. <ul style="list-style-type: none"> i) details of all the alternatives considered; ii) details of the public participation process undertaken in terms of regulation 41 of the Regulations, including copies of the supporting documents and inputs; iii) a summary of the issues raised by interested and affected parties, and an indication of the manner in which the issues were incorporated, or the reasons for not including them; iv) the environmental attributes associated with the alternatives focusing on the geographical, physical, biological, social, economic, heritage and cultural aspects; v) the impacts and risks identified for each alternative, including the nature, significance, consequence, extent, duration and probability of the impacts, including the degree to which these impacts – <ul style="list-style-type: none"> (aa) can be reversed; (bb) may cause irreplaceable loss of resources; and (cc) can be avoided, managed or mitigated. vi) the methodology used in determining and ranking the nature, significance, consequences, extent, duration and probability of potential environmental impacts and risks associated with the alternatives. 	Chapter 4 - 7
<ul style="list-style-type: none"> ▪ A full description of the process undertaken to identify, assess and rank the impacts the activity will impose on the preferred location through the life of the activity including – <ul style="list-style-type: none"> i) a description of all environmental issues and risks that were identified during the environmental impact assessment process; and ii) an assessment of the significance of each issue and risk and an indication of the extent to which the issue and risk could be avoided or addressed by the adoption of mitigation measures. 	Chapter 7
<ul style="list-style-type: none"> ▪ An assessment of each identified potentially significant impact and risk including – <ul style="list-style-type: none"> a) cumulative impacts; b) the nature, significance and consequences of the impact and risk; c) the extent and duration of the impact and risk; d) the probability of the impact and risk occurring; e) the degree to which the impact and risk can be reversed; 	Chapter 7

Appendix 1: Content of Basic Assessment Reports	Chapter/ Section
<ul style="list-style-type: none"> f) the degree to which the impact and risk may cause irreplaceable loss of resources; and g) the degree to which the impact and risk can be avoided, managed or mitigated. 	
<ul style="list-style-type: none"> ▪ Where applicable, a summary of the findings and impact management measures identified in any specialist report complying with Appendix 6 to these Regulations and an indication as to how these findings and recommendations have been included in the final report. 	Chapter 7 & 7.4.4
<ul style="list-style-type: none"> ▪ An environmental impact statement which contains- <ul style="list-style-type: none"> i) a summary of the key findings of the environmental impact assessment; ii) a map at an appropriate scale which superimposes the proposed activity and its associated structures and infrastructure on the environmental sensitivities of the preferred site indicating any areas that should be avoided, including buffers; and iii) a summary of the positive and negative impacts and risks of the proposed activity and identified alternatives. 	Chapter 7.4.4
<ul style="list-style-type: none"> ▪ Based on the assessment, and where applicable, impact management measures from specialist reports, the recording of the proposed impact management objectives, and the impact management outcomes for the development for inclusion in the EMPr. 	Chapter 7
<ul style="list-style-type: none"> ▪ Any aspects which were conditional to the findings of the assessment either by the EAP or specialist which are to be included as conditions of authorisation. 	Section 8.6.1
<ul style="list-style-type: none"> ▪ A description of any assumptions, uncertainties, and gaps in knowledge which relate to the assessment and mitigation measures proposed. 	Section 8.5
<ul style="list-style-type: none"> ▪ A reasoned opinion as to whether the proposed activity should or should not be authorised, and if the opinion is that it should be authorised, any conditions that should be made in respect of that authorisation. 	Section 8.6
<ul style="list-style-type: none"> ▪ Where the proposed activity does not include operational aspects, the period for which the environmental authorisation is required, the date on which the activity will be concluded, and the post construction monitoring requirements finalised. 	Section 8.6
<ul style="list-style-type: none"> ▪ An undertaking under oath or affirmation by the EAP in relation to: <ul style="list-style-type: none"> i) the correctness of the information provided in the reports; ii) the inclusion of comments and inputs from stakeholders and I&APs; iii) the inclusion of inputs and recommendations from the specialist reports where relevant; and any information provided by the EAP to interested and affected parties and any responses by the EAP to comments or inputs made by interested and affected parties. 	Section 8.7

Appendix 1: Content of Basic Assessment Reports	Chapter/ Section
<ul style="list-style-type: none"> Where applicable, details of any financial provisions for the rehabilitation, closure, and on-going post decommissioning management of negative environmental impacts. 	NA
<ul style="list-style-type: none"> Any specific information that may be required by the competent authority. 	<ul style="list-style-type: none"> <u>Please confirm the preferred alternative, ensure that the preferred alternative is indicated in both the application form and the final BAR and the impacts related to such are also assessed in the final BAR – <i>The preferred fuel type for this assessment is diesel and the impact assessment and application form has been updated to reflect this change.</i></u> <u>Please ensure that all relevant listed activities are applied for, are specific and can be linked to the development activity or infrastructure as described in the project description. Only activities applicable to the development must be applied for and assessed – <i>all relevant listed activities have been applied for.</i></u> <u>Ensure that specialist studies, where applicable comply with the requirements of GN 320 of 20 March 2020 and GN 1150 of 30 October 2020 unless proof is provided that indicates that the specialist study was commissioned within 50 days after the date of gazetting of the notice i.e. 20 March 2020 and was commissioned prior to 30 October 2020 respectively. Failure to comply with the abovementioned notices presents a risk to this application – <i>the specialist team have provided correspondence with regards to compliance with the protocols or updated their reports where applicable. Refer to Appendix C.</i></u> <u>Identified cumulative impacts must be clearly defined and a cumulative impact environmental statement must be provided – <i>refer to Sections 2.4 and 8.3 of this report.</i></u> <u>A locality map and a sensitivity map for the proposed development have been provided however the layout is not provided, ensure that the layout plan is provided as required in terms of Appendix 1 (3)(1) (c) – <i>the revised layout and sensitivity map is provided in Figure 1 and Figure 52 respectively.</i></u> <u>Please note that the final BAR must also have an undertaking under oath/ affirmation by the EAP – <i>refer to Section 8.7.</i></u> <u>The Public Participation Process must be conducted in terms of Regulations 39, 40, 41, 42, 43 & 44 of the EIA Regulations, 2014 – <i>refer to Appendix F.</i></u>
<ul style="list-style-type: none"> Any other matters required in terms of section 24(4)(a) and (b) of the Act. 	NA

1.3 Specialist Assessments

To ensure the scientific rigour of the BA study, as well as a robust assessment of impacts, a number of specialist inputs including the review and where applicable update of previously conducted and approved studies prepared for the previous seven ICE projects were obtained. This was undertaken in order to comprehensively identify both potentially positive and negative environmental impacts (social and biophysical) associated with the proposed project, and where possible to provide mitigation measures to reduce the potentially negative impacts and enhance the positive impacts (Table 2). The specialist studies can be found in **Appendix C**.

Table 2: Specialist assessments conducted for the project

Specialist Study	Organisation	Appendix
Soils and Agricultural Potential	Johann Lanz (private)	Appendix C1
Ecology	Bathusi Environmental Consultants	Appendix C2
Avifauna	Arcus Consulting Services	Appendix C3
Air Quality and Climate Change	Airshed Planning Professionals	Appendix C4
Noise	Acoustech	Appendix C5
Heritage	Johnny van Schalkwyk (private)	Appendix C6
Palaeontology	Natura Viva	Appendix C7
Visual	<u>Royal HaskoningDHV and peer reviewed by LOGIS</u>	Appendix C8

*conducted for the previous seven ICE environmental study.

1.4 Details of the Project Developer

The Developer is ACWA Power and the details of the responsible person are listed in Table 3 below.

Table 3: Applicant details

Applicant	Details	
Representative	Ashley Singh	
Physical Address	7th Floor 90 Grayston Drive Sandton 2196	
Telephone	(011) 722 4100	
E-mail	Asingh@acwapower.com	

1.5 Details of the Environmental Assessment Practitioner

The environmental team of Royal HaskoningDHV have been appointed as an Environmental Assessment Practitioner (EAP) by ACWA Power to undertake the appropriate environmental studies for this proposed project.

The professional team of Royal HaskoningDHV has considerable experience in the environmental management field. Royal HaskoningDHV been involved in and/ or managed several of the largest EIAs undertaken in South Africa to date. A specialist area of focus is on the assessment of multi-faceted projects,

including the establishment of linear developments (national and provincial roads, and powerlines), mixed-use developments, bulk infrastructure and supply (e.g. wastewater treatment works, pipelines, landfills), electricity generation and transmission, urban, rural and township developments, environmental aspects of Local Integrated Development Plans, as well as general environmental planning, development and management. Royal HaskoningDHV have previously worked on the ten PV Plants and seven ICE projects and have a good working knowledge of the project as a whole.

Details of the EAP are provided in Table 4 below.

Table 4: EAP details

Consultant	Royal HaskoningDHV	
Contact Persons	Prashika Reddy	Seshni Govender
Postal Address	PO Box 867, Gallo Manor, 2191	PO Box 867, Gallo Manor, 2191
Telephone	087 352 1577	087 352 1592
E-mail	prashika.reddy@rhdhv.com	Seshni.govender@rhdhv.com
Qualification	BSc (Hons) Geography BSc (Hons) Botany	BSc (Hons) Environmental Science
Expertise	Prashika Reddy is a Senior Environmental Scientist with 20 years' experience in various environmental fields including: EIAs, EMPs, PPP and environmental monitoring and audits. She is/ has been part of numerous multi-faceted large-scale projects, including the establishment of linear developments (roads and powerlines), industrial plants, electricity generation plants, mixed-use developments and mining projects. She is a Professional Natural Scientist (400133/10) with the South African Council for Natural Scientific Professions as well as a Registered EAP with EAPASA (2019/917).	Seshni Govender is an Environmental Consultant with 8 years' Environmental Consultant with eight (8) years working on compliance and strategic planning projects across South Africa. I have been involved in numerous Screening Studies, Basic Assessment, Water Use License projects, including complex integrated licensing that requires understanding cumulative environmental impacts. She is a Professional Natural Scientist (132741) with the South African Council for Natural Scientific Professions.

The Curriculum Vitae (CV) of the respective consultants can be found in **Appendix D**.

2 PROJECT DESCRIPTION

2.1 Property Details

The project area is located on the north eastern portion of the Farm Bokpoort 390 RE which is 20km north-west of the town of Groblershoop within Ward 3 of the !Kheis Local Municipality in the ZF Mgcawu District Municipality, Northern Cape Province. The total project area designated for the development of Bokpoort II is approximately 1500ha with the ICE occupying 1.5ha (0.5ha actual development footprint). The project site is situated approximately 77km south-east of Upington. The Orange River is located approximately 12km south-west of the site.

The landowner details as well as 21-digit surveyor general codes are provided in Table 5. Consent has been received from ACWA Power SolAfrica Bokpoort CSP as well as an option to lease agreement that is in place.

Table 5: Property details

Property	Owner	21 Digit Surveyor-General Code
Farm Bokpoort 390 RE	ACWA Power SolAfrica Bokpoort CSP Power Plant (Pty) Ltd (RF)	C02800000000038900000

2.2 Project Location and Co-ordinates

The corner point co-ordinates are provided in Table 6.

Table 6: Project co-ordinates

ICE	Corner Co-ordinates
Afrikaans ICE	A: 28°42'37.82"S; 22° 0'0.63"E, B: 28°42'37.66"S; 22° 0'2.53"E C: 28°42'40.40"S; 22° 0'2.62"E, D: 28°42'40.39"S; 22° 0'0.61"E

2.3 Technical Description

Combustion engines are a well-known technology used in automobiles, trucks, construction equipment, marine propulsion, and backup power applications. Combustion engines employ the expansion of hot gases to push a piston within a cylinder, converting the linear movement of the piston into the rotating movement of a crankshaft to generate power. While the steam engines that powered the industrial revolution were driven by externally produced steam, modern combustion engines used for electric power generation are internal combustion engines in which an air-fuel mixture is compressed by a piston and ignited within a cylinder. Reciprocating ICE are characterized by the type of combustion: spark-ignited (SG) or compression-ignited, also known as diesel or gas.

In diesel engines, air is compressed until the temperature rises to the auto-ignition temperature of the fuel. As the fuel is injected into the cylinder, it immediately combusts with the hot compressed air and expanding combustion gases push the piston to the bottom of the cylinder. A built-in heat exchanger for turbo cooling that improves shock load response and facilitates remote cooling, providing flexibility in indoor installations (Figure 2).

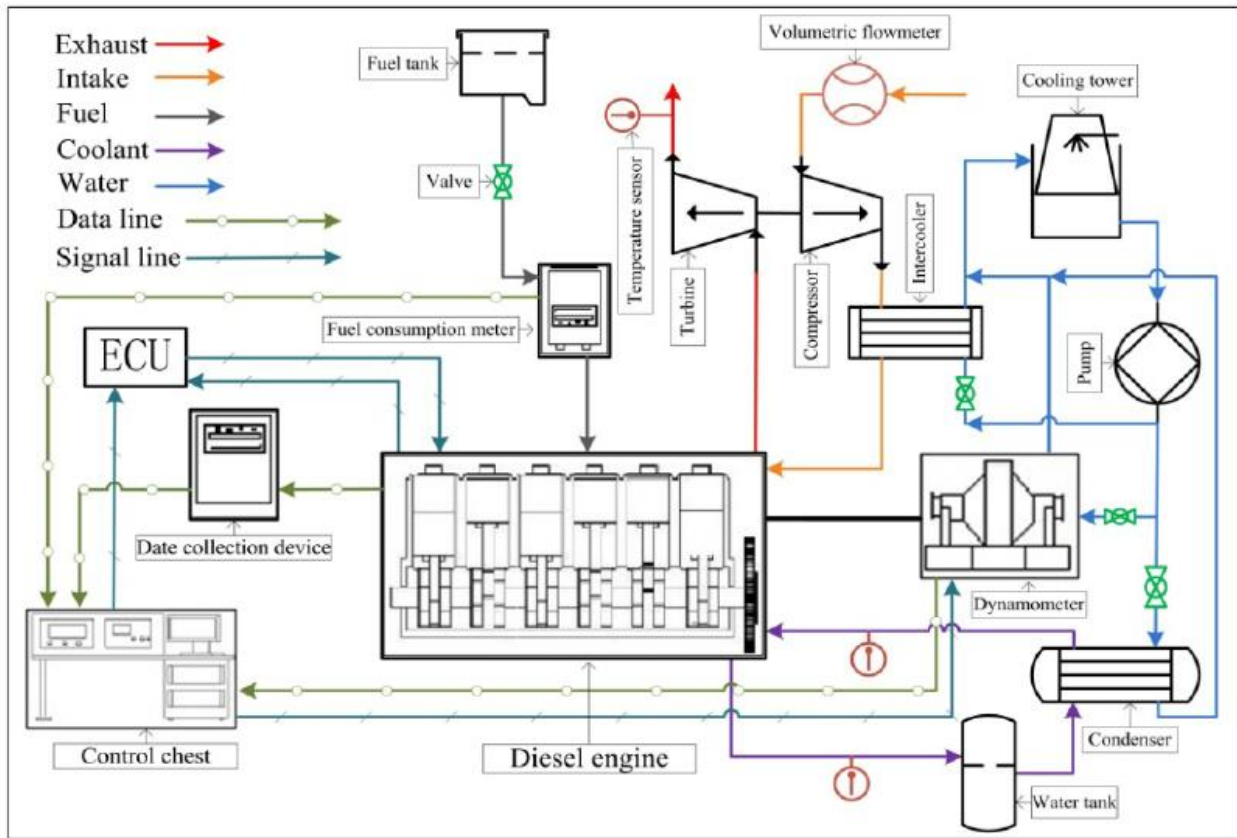

Figure 2: Example of a diesel engine flow chart

For Project DAO, high speed engine four stroke generating set will be applied (Figure 3). The primary fuel will be diesel. The diesel will be transferred to the plant *via* oil road tankers and, the interface point will be at the uploading station inside the power plant boundary. The engine and alternator are a containerised infrastructure (Figure 4), that will be placed on an appropriately bunded civil plant areas. The developer will be responsible for the diesel via a fuel supplier.

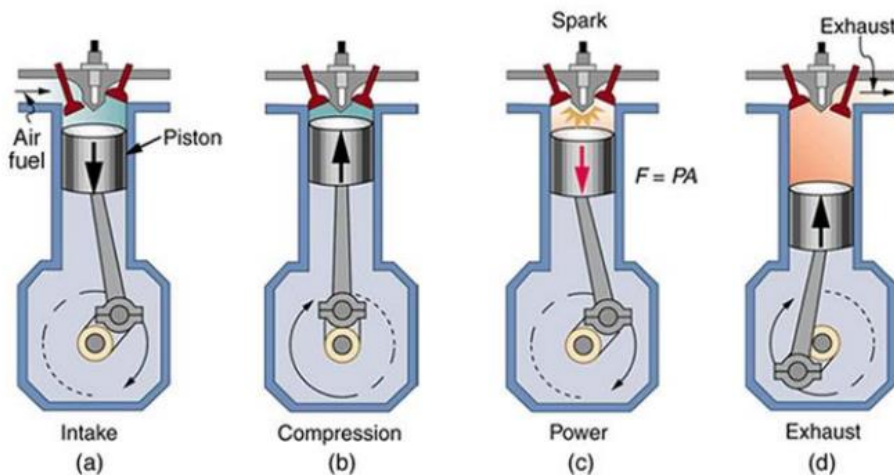

Figure 3: The four stages of combustion in a four-reciprocating engine



Figure 4: Example of a containerised ICE

The components of an ICE are presented in Figure 5.

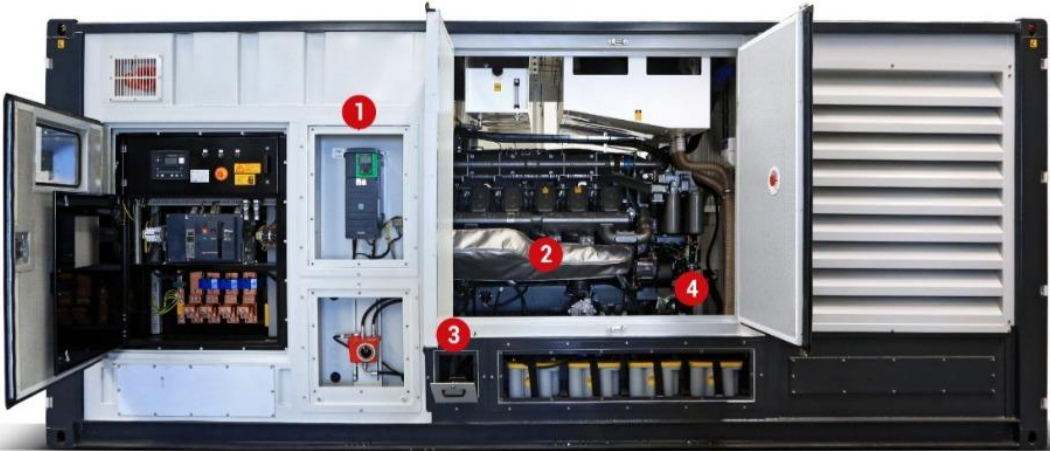



Figure 5: Layout of a Himoinisa ICE

(Key – 1: Remote cooling system, 2: Heat insulated engine parts, 3: Battery disconnecter, 4: Air filter, 5: Refuelling connectors)

The ACWA Power Project DAO is a multi-technology hybrid power plant that is designed to meet the requirements of the Risk Mitigation IPP Procurement (RMIPPPP). The plant has a contracted capacity on the output side onto the transmission system of 150MW. The hybrid power plant consists of 326MW of Photovoltaic (PV), Battery Energy Storage System (BESS) of 540-560MWhrs and ICE of 49.5MW.

The project is dispatched according to needs of the off-taker that is limited to daily availability declarations. The plant is designed to meet its obligations of dispatch as per its available energy from the renewable components of the plant, so it can in essence be considered a PV and BESS power plant.

The RMIPPPP has a dispatchable period requirement of 16.5 hours per day. The RMIPPPP has a reliability test run requirement, that must be executed prior to the start of the operating period of the Power Purchase Agreement (PPA). The requirement of the reliability run is that the power plant must operate at full contracted capacity, 150MW, for the duration of 15 days with some additional starts and stops within that period. Failure to achieve the reliability run, results in the plant being rejected and not achieving the commercial operating date with the risk that the PPA can be terminated.

As the plant is primarily designed for renewable energy from the sun, ensuring a guaranteed 15-day window at 100% capacity of 150MW has a low probability. Hence the design incorporated the ICE component to primarily assist the reliability testing regime. The reliability run places reliance from an energy input from the ICE over a 24-hour period to compensate for low availability of sunlight during the testing regime. Depending on the specific period of the year (weather conditions of the day, seasonality of the year) of the reliability run, the ICE may run for a full 24-hour period, charging the batteries in those periods that are not dispatchable. The design has catered for certain quantity of diesel to be stored at site for the reliability run requirements with a logistic supply solution to meet additional diesel requirements, should it be required.

During the operational phase of the project, it is envisaged that the ICE plant will not be required to provide any energy output to the grid. However, from a prudent operating perspective and to ensure that the ICE plant is appropriately maintained, a start-and-stop regime is envisaged to sustain plant integrity. To meet these requirements, the ICE plant will be operated for 2 hours per week during the operational phase of the plant for 20 years. The plant will use diesel delivered to site by tanker truck for thermal generation of electricity in reciprocating engines. The diesel will be stored in containerised storage tanks on-site. The ICE plants will include reciprocating engines, diesel storage, and ancillary infrastructure. The three authorised

ICE plants situated at the Venda, Pedi and Afrikaans PV plants as well as the two additional ICE at the Afrikaans and Sotho PV plants will allow for individual fuel uploading, fuel storage and regasification system. Each ICE plant will have their own safety mechanisms in place such as fire extinguishers and exhaust systems.

2.3.1 Benefits of ICE in Renewable Projects

- A combustion engine power plant can start and ramp to full load very quickly due to rapid ignition of fuel within the cylinders and the coordinated starting of multiple generating sets.
- Reciprocating ICE often have a standardized, modular design that minimises construction time. The modular design of these units that can be operated in parallel and deployed as needed to match the changing power requirements and can serve an important function for the stability of electricity transmission grids.

Table 7 summarises the main technical details for an ICE and associated infrastructure.

Table 7: Technical details of the proposed ICE

Facility Component	Description/ Dimensions
Generating Capacity	9.9MW
Fuel Type	<u>Diesel</u>
Stack height	<u>5.8m</u>
Number of engines	<u>11</u>
Fuel storage tanks	<u>2 x 71.6m³ and 1 x 35.3m³ (Total volume = 178.5m³)</u>
Fuel volume	Combined capacity of less than 500m ³
Water requirements	Water for cooling which falls within the already assessed threshold i.e. 22 000m ³
Footprint	<u>Site extent 1.5ha (0.5ha actual development footprint)</u>

The layout for the ICE at the Afrikaans PV Plant is provided in **Appendix A.**

2.4 Need & Desirability

Table 8: Project need, desirability and benefits

(i) Is the activity permitted in terms of the property's existing land use rights?	YES		Please explain
<p>ACWA Power Solafrica Bokpoort CSP Power Plant (Pty) Ltd is the landowner of the Farm Bokpoort 390 RE and has leased the property to ACWA Power for the development of the Bokpoort II project. On 11 January 2017, ACWA Power obtained an approval for the rezoning of farm for Agriculture Zone 1 to a Special Zone (Solar Energy Facility). The activity is therefore permitted in terms of the property's existing land use rights.</p>			
(ii) Will the activity be in line with the following?			
(a) Provincial Spatial Development Framework (PSDF)	YES		Please explain
<p>The proposed activity which is a supporting infrastructure required for the efficient generation of renewable energy can be considered in line with the Northern Cape PSDF (2018) Energy Policy, which states that "renewable energy sources (e.g. wind, solar thermal, biomass, and domestic hydroelectricity generation) are to comprise 25% of the province's energy generation capacity by 2030" and the PSDF Objectives which include "to promote the development of renewable energy supply schemes. Large-scale renewable energy supply schemes are strategically important for increasing the diversity of domestic energy supplies and avoiding energy imports while minimizing detrimental environmental impacts".</p> <p>Recognising the suitability of the province to optimise the use of solar power, the Northern Cape Provincial Spatial Development Framework (PSDF) has set the following energy objectives for the province:</p> <ul style="list-style-type: none"> ▪ to promote the development of renewable energy supply schemes; ▪ to reinforce the existing transmission network and to ensure a reliable electricity supply in the Northern Cape; ▪ to develop and institute innovative new energy technologies to improve access to reliable, sustainable and affordable energy services with the objective to realise sustainable economic growth and development; and ▪ to develop and institute energy supply schemes with the aim to contribute to the achievement of the targets set by IRP 2010 – 2030. <p>Solar thermal water heating and photovoltaic energy generation are to be compulsory, linked to main electricity sources as backup, on all new residential, commercial, industrial and community buildings, and should be progressively phased in as appropriate.</p>			
(b) Urban edge / Edge of Built environment for the area		NO	Please explain
<p>The project is located outside of the urban edge. The proposed development site is in a remote, rural area and so it will neither contribute to, nor compromise urban growth.</p>			
(c) Integrated Development Plan (IDP) and Spatial Development Framework (SDF) of the Local Municipality (e.g. would the approval of this application compromise the integrity of the existing approved and credible municipal IDP and SDF?).		NO	Please explain
<p>According to the !Kheis Local Municipality IDP 2017-2022: "The Municipality is in the middle of the Presidential Infrastructure Coordinating Committee (PICC), Strategic Infrastructure Program (SIP) and is therefore part of the Special Economic Development Zone of the Solar Corridor. !Kheis Municipal area could benefit from a number of programs that are not available to other Municipalities, and must be incorporated in the approach in the IDP.</p> <p>Solar energy is a natural resource like water, mining, iron and copper. A lot of macro solar projects are being developed around the Municipality. Micro solar opportunities can assist sustainability of the Municipality by attracting new businesses and provision of basic services to residents. The Municipal area has a high solar radiation which can open enormous potential of green technology and innovation such as powering solar vehicles to render basic services. This resource can be a major advantage to assist the poor rural communities in creation of jobs and providing electricity to under privilege families and business opportunities."</p> <p>Therefore, this project is in line for the vision for the Municipality towards a sustainable low carbon future.</p>			

(d) Approved Structure Plan of the Municipality		NO Please explain
<p>As stated above a key opportunity for the Municipality is to develop green technologies. The unique positioning of the Municipality in the country allows it to achieve its green technologies objective. This is further supported by the Northern Cape PSDF which highlights the importance of renewable energy component of the surface infrastructure for the Municipality. Renewable energy orientated innovation and knowledge economy could play a critical role towards leap-frogging the green economy which could create enormous economic opportunities for the Northern Cape Province.</p>		
(e) An Environmental Management Framework (EMF) adopted by the Department (e.g. Would the approval of this application compromise the integrity of the existing environmental management priorities for the area and if so, can it be justified in terms of sustainability considerations?)		NO Please explain
<p>The ZF Mgcawu District Municipality (formerly known as the Siyanda District) EMF within the !Kheis Municipality IDP (2014 - 2015) states that the climate of the area poses huge potential to utilise solar energy more widely, especially in the remote areas of the district. The proposed activity is a solar plant which is a sustainable and renewable operation that provides an additional economic resource to the area.</p> <p>Furthermore, this BA study is a mechanism of a management intervention that considers the principles of the National Environmental Management Act which includes sustainability.</p>		
(f) Any other Plans (e.g. Guide Plan)		NO Please explain
<p>The IRP 2019 stated that the “Solar PV, wind and CSP with storage present an opportunity to diversify the electricity mix, to produce distributed generation and to provide off-grid electricity. Renewable technologies also present huge potential for the creation of new industries, job creation and localisation across the value chain.”</p> <p>According to the National Climate Change Adaptation Strategy - NCCAS (2019)⁶ climate change is defined as a change in the state of the climate that can be identified (e.g. by using statistical tests) by changes in the mean and/ or the variability of its properties and that persists for an extended period, typically decades or longer. Climate change may be due to natural internal processes or external forces, such as modulations of the solar cycles, volcanic eruptions and persistent anthropogenic changes in the composition of the atmosphere or in land use.</p> <p>The National Climate Change Adaptation Strategy (NCCAS) provides a common vision of climate change adaptation and climate resilience for the country, and outlines priority areas for achieving this vision. The NCCAS goes beyond water, agriculture and commercial forestry, health, biodiversity and ecosystems, human settlements (urban, rural and coastal), and disaster risk reduction and management sectors to include transportation and infrastructure, energy, mining, oceans and coast. One of the actions to achieve climate change considerations is that all public infrastructure (including transport and energy infrastructure) be planned, designed, operated and managed after explicitly taking current and predicted future climate change impacts into account.</p> <p>ACWA Power will be participating in the Department of Mineral Resource and Energy (DMRE) Renewable Projects and/ or Captive Power Projects through their authorised PV projects. Like any other solar technology, PV can only generate electricity when the weather is favourable. The country is in dire need of electricity and especially during peak hours. In order to address this need, ACWA Power is proposing additional infrastructure within their plants to create the flexibility and efficiency of the plants to allow for electricity generation during unfavourable weather conditions and this can be achieved by having additional ICE.</p>		

⁶ Department of Environment, Forestry and Fisheries. 2019. National Climate Change Adaptation Strategy. Version UE10.

(iii) Is the land use (associated with the activity being applied for) considered within the timeframe intended by the existing approved SDF agreed to by the relevant environmental authority (i.e. is the proposed development in line with the projects and programmes identified as priorities within the credible IDP)?	YES	Please explain
<p>From a cumulative impact perspective, the project poses no threat to the land uses, the location of the project is in a strategically important area known as renewable energy development zones (REDZ). REDZ are gazetted geographical areas:</p> <ul style="list-style-type: none"> ▪ In which clusters (several projects) of wind and PV solar development will have the lowest negative impact on the environment while yielding the highest possible social and economic benefit to the country; ▪ That are widely agreed to have strategic importance for wind and PV solar development; ▪ Where the environmental and other authorisation processes have been aligned and streamlined based on scoping level pre-assessment and clear development requirements; ▪ Where pro-active and socialised investment can be made to provide time efficient infrastructure access <p>The study area falls within the REDZ 7 (Figure 6) which is earmarked for large scale solar energy facilities and is within the Northern Corridor Strategic Transmission Corridor.</p> <p>As stated above, it is one of the initiatives of the Municipality to use this opportunity for the improvement of the community by ensuring that these solar plants directly benefit the Municipality through the creation of jobs as well as creating self-sufficient cities.</p>		
(iv) Does the community / area need the activity and the associated land use concerned (is it a societal priority)? (This refers to the strategic as well as local level (e.g. development is a national priority, but within a specific local context it could be inappropriate.)	YES	Please explain
<p>The recent power cuts or load shedding events by Eskom have emphasised the need for additional power generation capacity in South Africa. There is a focus on moving towards increased generation from renewable energy sources. The DMRE's RMIPPP is designed to stimulate more independent power producers to meet the country's ever-growing electricity demand. The IRP 2019 being implemented by the DMRE, highlights the electricity demand forecasts and Government's plan to meet this demand through a variety of approaches and technologies, one of which is to implement more renewable energy projects.</p> <p>Due to South Africa's electricity generation and supply system being overloaded, the demand for an increased and stable electricity supply is a priority not only in the Northern Cape, but in all the other South African provinces. Solar energy plants are important for reducing the country's overall environmental footprint from power generation and for directing a pathway towards sustainability. Thus, the proposed project addresses a national/strategic priority.</p>		
(v) Are the necessary services with adequate capacity currently available (at the time of application), or must additional capacity be created to cater for the development?	YES	Please explain
<p>There are no services at the site, and none will be required from the Municipality. The construction of a new water supply pipeline, access roads, a powerline from the PV installation to Eskom's Garona substation has already been authorised. Domestic and office waste will be removed by a Contractor.</p>		
(vi) Is this development provided for in the infrastructure planning of the municipality, and if not what will the implication be on the infrastructure planning of the municipality (priority and placement of services and opportunity costs)?		NO Please explain
<p>The infrastructure required for the proposed development is to be provided and maintained by both the Developer and the end user, and it will not conflict with municipal infrastructure planning or priorities. In addition, the proposed development is to be constructed on overgrazed agricultural land outside of an urban area, with little or no existing or planned infrastructure.</p>		

(vii) Is this project part of a national programme to address an issue of national concern or importance?	YES		Please explain
The project aims at meeting the National Development Plan objectives. The National Development Plan states the following as a priority objective: <i>Procuring at least 20 000 MW of renewable electricity by 2030, importing electricity from the region, decommissioning 11 000 MW of ageing coal-fired power stations and stepping up investments in energy-efficiency.</i>			
(viii) Do location factors favour this land use (associated with the activity applied for) at this place? (This relates to the contextualisation of the proposed land use on this site within its broader context.)	YES		Please explain
<p>The Northern Cape has been recognised as having the highest solar resource in the country and so is ideally suited to solar power generation. Furthermore, this is in keeping with the Bokpoort CSP Plant which is in its 5th year of operation and is close to the proposed site. The proposed site is well located in terms of proximity to Eskom's Garona Substation and road access (Transnet Service Road).</p> <p>From a cumulative impact perspective, the location of the project is in a strategically important area known as renewable energy development zones (REDZ) 7: Upington and has been identified as one of the most suitable areas in the country for renewable energy development, in terms of several environmental impacts, economic and infrastructural factors.</p>			
(ix) Is the development the best practicable environmental option for this land/site?	YES		Please explain
The site is within one of South Africa's eight REDZs i.e. <i>REDZ 7 Upington</i> , applicable to Large scale solar PV facilities and has therefore been identified as one of the most suitable areas in the country for renewable energy development, in terms of several environmental impacts, economic and infrastructural factors. Renewable energy development is therefore a very suitable land use option for the site. The property is already partly developed for renewable power generation. The current development (Bokpoort I) comprises a CSP parabolic trough facility generating 50 MW of electricity. The property is well located in terms of connection to power infrastructure and water availability.			
(x) Will the benefits of the proposed land use/development outweigh the negative impacts of it?	YES		Please explain
<p>The proposed activity will assist in the supply of renewable energy to Eskom and will consequently increase the amount of electricity available to users. The site is well positioned for production of renewable energy given its proximity to a key grid substation and Eskom transmission lines together with access to water (Orange River). The site is already partly developed for renewable power generation. These are positive factors in motivation of extending renewable energy production at the site.</p> <p>Potential negative impacts are anticipated however these can be mitigated.</p>			
(xi) Will the proposed land use/development set a precedent for similar activities in the area (local municipality)?		NO	Please explain
The existing Bokpoort I project has already set a precedent and the extension of renewable energy production at the site will be in line with the REDZ for large scale solar PV facilities.			
(xii) Will any person's rights be negatively affected by the proposed activity/ies?		NO	Please explain
The public participation process will allow I&AP's an opportunity to raise any concerns with the proposed project.			

(xiii) Will the proposed activity/ies compromise the “urban edge” as defined by the local municipality?		NO Please explain
<p>It is not foreseen that the proposed project and associated activities will compromise the “urban edge” as the project components fall outside the urban edge.</p> <p>The proposed development site is located a short distance outside the rural town of Groblershoop and approximately 110 km by road from Upington. Infrastructure within these towns is under pressure from a variety of solar development projects which are currently under construction in the area. The introduction of a large construction workforce, as is typical of this type of development, will place further strain on the municipal infrastructure, but the relatively small workforce associated with the operation of the proposed PV plants is unlikely to require an expansion of the urban edge of any town.</p>		
(xiv) Will the proposed activity/ies contribute to any of the 17 Strategic Integrated Projects (SIPs)?		NO Please explain
<p>The proposed development is a supporting activity that is in line with Strategic Integrated Projects (SIPs) in that it relates to social and economic infrastructure across all nine provinces and include catalytic projects that can fast-track development and growth but the process of being a SIP project has not been initiated. SIP 9: Electricity generation aims at supporting socio- economic development (Accelerate the construction of new electricity generation capacity in accordance with the IRP to meet the needs of the economy and address historical imbalances).</p>		
(xv) What will the benefits be to society in general and to the local communities?	Please explain	
<p>The access to adequate electricity is a basic human right, which will also ensure the growth and development of the area is maintained as the project area is an important economic area within the municipality.</p> <p>The project is also in line with Sustainable Development Goal 7 (SDG 7) which stipulates <i>Affordable and Clean Energy</i> for all. Investing in solar, wind and thermal power, improving energy productivity, and ensuring energy for all is vital if we are to achieve SDG 7 by 2030. Expanding infrastructure and upgrading technology to provide clean and more efficient energy in all countries will encourage growth and help the environment.</p>		
(xvi) Any other need and desirability considerations related to the proposed activity?	Please explain	
<p>Society: The operations will contribute electricity to the National Grid, thereby improving Eskom’s ability to meet the growing demands of the country. Additional power on the National Grid will in turn mean a lesser likelihood of power outages and an increased amount of power for the Nation’s industrial sector to operate more efficiently, which is of critical importance to the national economy.</p> <p>Communities: The project will have a positive socio-economic impact with an increase in job opportunities and indirect economic spin offs. Among those employed for the project, skills will be developed through training thus bringing about empowerment for both permanent and temporary employees. The jobs generated would benefit households by uplifting their socio-economic standards through an increase in income. Secondary jobs and income sustainability will also be created in terms of repair and supply of the solar panels.</p> <p>The circulation of additional money within the micro-economy will also benefit those who are not directly affiliated with the project. As people will receive an increased income, they will have more money to spend on amenities for both themselves and their families, thus uplifting the local and national economy via the energy saved and jobs created from this initiative.</p>		

(xvii) How does the project fit into the National Development Plan for 2030?	Please explain
	<p>The National Development Plan for 2030 seeks to promote economic growth and development through the provision of quality energy services that are competitively priced, reliable and efficient. The National Development Plan also seeks to promote social equity through the expansion of access to energy services.</p> <p>The National Development Plan states the following as a priority objective: <i>Procuring at least 20 000 MW of renewable electricity by 2030, importing electricity from the region, decommissioning 11 000MW of ageing coal-fired power stations and stepping up investments in energy-efficiency.</i></p> <p>This project provides an opportunity to ensure the success to ensure that the PV plants operate optimally to ensure this goal is met.</p>
(xviii) Please describe how the general objectives of Integrated Environmental Management as set out in section 23 of NEMA have been taken into account.	<p>The impacts associated with the proposed project will be identified, predicted and evaluated to minimise negative impacts, maximise benefits and promote compliance with the principles of environmental management set out in Section 2 of NEMA (Section D). Mitigation and management measures to minimize negative impacts and maximize benefits from the proposed project have been included in the EMPr attached as Appendix E to this Report.</p>
(xix) Please describe how the principles of environmental management as set out in section 2 of NEMA have been taken into account.	<p>The proposed project will be sustainable in terms of the following:</p> <ul style="list-style-type: none"> ▪ Social: Local communities will benefit from the project in terms of receiving adequate electrical supply that serve to meet basic human needs. The local community and society in general will also benefit from the project in terms of direct and indirect job creation. ▪ Economic: Provision of adequate electrical supply is a major contributor to the economic development. Society in general will benefit from the project in terms of indirect job creation as it will contribute to improving service delivery. ▪ Environmentally: the proposed project will avoid as far as practically possible any environmentally and socially sensitive areas such as human settlements and where this is not possible, mitigation measures have been proposed to minimise the impact. ▪ An EMPr (Appendix E) has been compiled that provides the actions for the management of identified environmental impacts emanating from the project and a detailed outline of the implementation programme to minimise and/ or eliminate the anticipated negative environmental impacts.

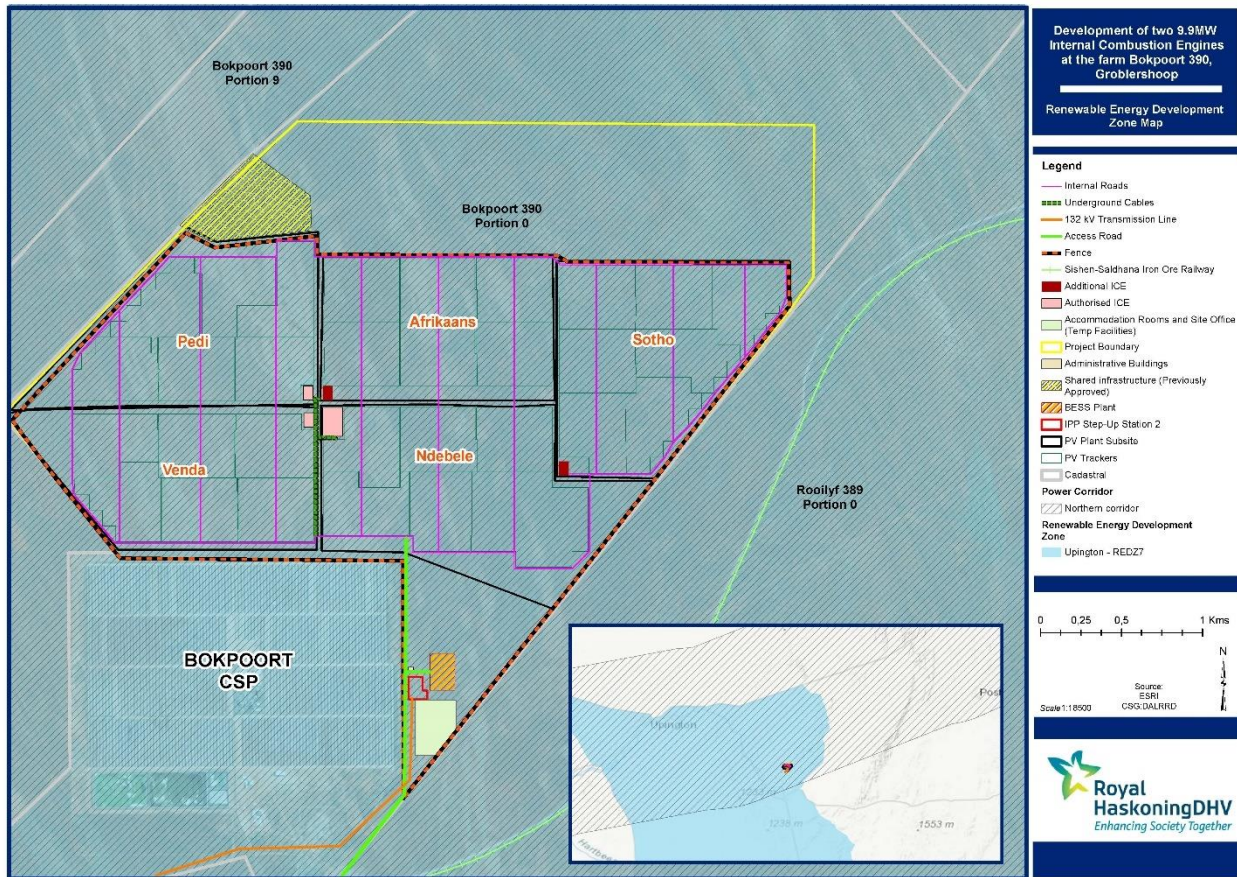

Figure 6: REDZ map

2.5 Socio-economic Value

The socio-economic details for the PV plant development including ICE are provided in Table 9.

Table 9: Socio-economic details

Description	Details
What is the expected capital value of the activity on completion?	R 1.2 billion
What is the expected yearly income that will be generated by or as a result of the activity?	R 180 million
Will the activity contribute to service infrastructure?	Yes
Is the activity a public amenity?	No
How many new employment opportunities will be created in the construction phase of the activity?	100 to 250 construction jobs and 20 to 40 permanent operations and maintenance positions during its lifespan
What is the expected value of the employment opportunities during the construction phase?	R 350 million
What percentage of this will accrue to previously disadvantaged individuals?	This will be in-line with the economic obligations under the implementation agreement which will be between IPP and the DMRE

Description	Details
How many permanent new employment opportunities will be created during the operational phase of the activity?	20 - 40 jobs
What is the expected current value of the employment opportunities during the first 10 years?	R 20 million/ annum
What percentage of this will accrue to previously disadvantaged individuals?	This will be in-line with the economic obligations under the implementation agreement which will be between IPP and the DMRE

3 ENVIRONMENTAL LEGISLATIVE CONTEXT

In order to protect the environment and ensure that the development is undertaken in an environmentally responsible manner, there are a number of significant environmental legislation (Table 10) that need to be considered during this study.

This section outlines the legislation that is applicable to the proposed project and has been considered in the preparation of this report.

Table 10: Key legislation considered

Acts	Objectives, important aspects, associated notices and regulations
<p>National Environmental Management Act, 1998 (Act No. 107 of 1998)(as amended)</p>	<p>Objectives: To provide for co-operative environmental governance by establishing principles for decision-making on matters affecting the environment, institutions that will promote co-operative governance and procedures for co-ordinating environmental functions exercised by organs of state.</p> <p>Relevant Notices and Regulations:</p> <ul style="list-style-type: none"> ▪ Environmental Impact Assessment Regulations, 2014 (GNR 326 in GG 40772 as amended) ▪ Listing Notice 1 (GNR 327) as amended ▪ Listing Notice 2 (GNR 325) as amended ▪ Listing Notice 3 (GNR 324) as amended <p>Relevance to the proposed project:</p> <ul style="list-style-type: none"> ▪ Development must be socially, environmentally and economically sustainable. ▪ Environmental management must be integrated, acknowledging that all elements of the environment are linked and interrelated; the social, economic and environmental impacts of activities including disadvantages and benefits, must be considered, assessed and evaluated and decisions must be appropriate in the light of such consideration. ▪ 'Polluter Pays' principle. ▪ Any activity that is proposed and which is listed in the NEMA EIA Regulations, requires environmental authorisation. <p>Listed Activity/ ies & Applicability:</p> <p>Listing Notice 1</p> <ul style="list-style-type: none"> ▪ <u>Activity 2 - The development and related operation of facilities or infrastructure for the generation of electricity from a non-renewable resource where – (ii) the output of 10 megawatts or less but the total extent of the facility covers an area in excess of 1 hectare.</u> <u>Applicability - The development and operation of the ICE with the total generating capacity of 9.9MW to be developed on an area of 1.5ha (cumulative extent of 1ha with a 0.5ha actual development footprint per ICE).</u> ▪ Activity 14 - The development and related operation of facilities or infrastructure, for the storage, or for the storage and handling, of a dangerous good, where such storage occurs in containers with a combined capacity of 80m³ or more but not exceeding 500m³. <u>Applicability: Diesel will be stored in three (3) storage tanks (2 x 71.6 m³ fuel tanks and 1 x 35.3 m³ fuel tank) with a combined volume not exceeding 500m³. Total volume = 178.5m³</u>

Acts	Objectives, important aspects, associated notices and regulations
	<ul style="list-style-type: none"> ▪ <u>Activity 27 - The clearance of an area of 1ha or more, but less than 20ha of indigenous vegetation, except where such clearance of indigenous vegetation is required for – (i) the undertaking of a linear activity; or (ii) maintenance purposes undertaken in accordance with a maintenance management plan. <i>Applicability - The construction of the proposed 9.9MW ICE on an area of 1.5ha (cumulative clearance of 1ha indigenous vegetation with a 0.5ha actual development footprint per ICE).</i></u> ▪ <u>Activity 28 - Residential, mixed, retail, commercial, industrial or institutional developments where such land was used for agriculture on or after 01 April 1998 and where such development will occur outside an urban area, where the total land to be developed is bigger than 1ha. <i>Applicability - The 9.9MW ICE will entail the development on 1.5ha (cumulative clearance of 1ha indigenous vegetation with a 0.5ha actual development footprint per ICE) of agricultural land. The project site is located outside an urban area.</i></u>
National Water Act (Act No. 36 of 1998) (as amended)	<p>Objectives: The National Water Act (NWA) is a legal framework for the effective and sustainable management of water resources in South Africa. Central to the NWA is recognition that water is a scarce resource in the country which belongs to all the people of South Africa and needs to be managed in a sustainable manner to benefit all members of society. The NWA places a strong emphasis on the protection of water resources in South Africa, especially against its exploitation, and the insurance that there is water for social and economic development in the country for present and future generations.</p> <p>Relevance to the proposed project:</p> <ul style="list-style-type: none"> ▪ Sustainable protection, use, development and conservation of water resources – including aquatic ecosystems. ▪ Defines 11 water uses and provides licencing procedures. <p>Notices and Regulations:</p> <ul style="list-style-type: none"> ▪ General Authorisation in terms of Section 39 of the National Water Act (Act No. 36 of 1998, Water Uses Section 21 (a) and (b) (GN in GG 40243 of 02 September 2016). ▪ General Authorisation in terms of Section 39 of the National Water Act (Act No. 36 of 1998, Water Uses Section 21 (c) and (i) (GN in GG 40229 of 26 August 2016).
National Environmental Management: Air Quality Act (Act No 39 of 2004)	<p>Section 32 - Control of dust. Section 34 - Control of noise. Section 35 - Control of offensive odours.</p> <ul style="list-style-type: none"> ▪ Listed Activities and Minimum National Emission Standards published in 2013 (GN 893, in Government Gazette No. 37054) as amended by GN 551, 12 June 2015; GN 1207, 81 October 2018 and GN 687, 22 May 2019). ▪ Air Dispersion Modelling promulgated in GN 533, in Government Gazette No. 37804; 11 July 2014. ▪ National Ambient Air Quality Standards promulgated in GN 1210 on 24 December 2009, in Government Gazette No. 32816. ▪ National Dust Control Regulations published on the 1st of November 2013 (Government Gazette No. 36974 R.827). ▪ Declaration of Greenhouse Gases as Priority Air Pollutants (21 July 2017). ▪ National Greenhouse Gas Emission Reporting Regulations (03 April 2017).

3.1 Other Relevant Acts, Guidelines, Department Policies and Environmental Management Instruments

Table 11: Other relevant acts, guidelines, policies and environmental management instruments

Acts/Guideline/Policies/Environmental Management Instruments	Considerations
The Constitution (No. 108 of 1996)	Chapter 2 – Bill of Right Section 24 – Environmental Rights
National Environmental Management Biodiversity Act (Act No. 10 of 2004) and Regulations: <ul style="list-style-type: none"> ▪ Threatened or protected species (GN 388) ▪ Lists of species that are threatened or protected (GN 389) ▪ Alien and invasive species regulations (GNR 506) ▪ Publication of exempted alien species (GNR 509) ▪ Publication of National list of invasive species (GNR 507) ▪ Publication of prohibited alien species (GNR 508) 	Provide for the protection of species and ecosystems that warrant national protection and the sustainable use of indigenous biological resources.
National Environmental Management: Waste Act (Act No. 59 of 2008) as amended	<p>Section 17 - Every attempt must be made to reduce, recycle or re-use all waste before it is disposed.</p> <p>Section 25 - All waste (general and hazardous) generated during construction may only be disposed of at appropriately licenced waste disposal sites.</p> <p>All waste management activities (e.g. recycling, treatment) meeting the relevant thresholds should be authorised under the National Environmental Management: Waste Act (Act No. 59 of 2008) [NEM:WA] (as amended) and Government Notice (GN) 921 of 29 November 2013 (as amended in 2015 and 2017). No person may commence, undertake or conduct a waste management activity listed GN 921 (as amended) unless a licence is issued in respect of that activity.</p>
National Heritage Resources Act (Act No. 25 of 1999)	<p>Section 34 - No person may alter or demolish any structure or part of a structure which is older than 60 years without a permit issued by the relevant provincial heritage resources authority.</p> <p>Section 35 - No person may, without a permit issued by the responsible heritage resources authority destroy, damage, excavate, alter, deface or otherwise disturb any archaeological or palaeontological site.</p> <p>Section 36 - No person may, without a permit issued by the South African Heritage Resource Agency (SAHRA) or a provincial heritage resources authority destroy, damage, alter, exhume, remove from its original position or otherwise disturb any grave or burial ground older than 60 years which is situated outside a formal cemetery administered by a local authority. "Grave" is widely defined in the Act to include the contents, headstone or other</p>

Acts/Guideline/Policies/Environmental Management Instruments	Considerations
	<p>marker of such a place, and any other structure on or associated with such place.</p> <p>Section 38 (a) - the construction of a road, wall, powerline, pipeline, canal or other similar form of linear development or barrier exceeding 300m in length; (b) the construction of a bridge or similar structure exceeding 50m in length; (c) any development or other activity which will change the character of a site (i) exceeding 5000m² in extent.</p>
Electricity Regulation Act No. 4 of 2006 as amended by the Electricity Regulation Amendment Act No. 28 of 2007	These regulations regulate the use and generation of electricity.
Occupational Health and Safety Act (Act No. 85 of 1993)	<p>Section 8 - General duties of employers to their employees.</p> <p>Section 9 - General duties of employers and self-employed persons to persons other than their employees.</p>
Construction Regulations (2014)	Contractors must comply with the Construction Regulations which lay out the framework for construction related activities.

Other:

Hazardous Substance Act (Act No. 15 of 1973) and Regulations
 Conservation of Agricultural Resources Act (Act No. 43 of 1983)
 Civil Aviation Act (Act No. 13 of 2009) and Civil Aviation Regulations (CAR) of 1997
 Electricity Act (Act No. 41 of 1987)
 Civil Aviation Authority Act (Act No. 40 of 1998)
 White Paper on Renewable Energy (2003)
 Integrated Resource Plan for South Africa (2019)
 Environmental Impact Assessment Guidelines for Renewable Energy Projects, GNR 989 of 2015 in terms of NEMA (Act No. 107 of 1998)
 Land Use Planning Ordinance (Ordinance 15 of 1985)
 National Road Traffic Act (Act No. 93 of 1996)
 Procedure to be followed in Applying for Environmental Authorisation for Large Scale Wind and Solar Photovoltaic Energy Development Activities in terms of Section 24(2)a of NEMA, 1998 when occurring in Geographical Areas of Strategic Importance (GG No. 114, 16 February 2018)
 National Climate Change Adaptation Strategy (2019) Version UE10
 South African National Climate Change Response Policy (2011)
 Carbon Tax Act (Act No. 15 of 2019)
 National GN R154 National Noise Control Regulations
 SANS 10103:2008, the *Measurement and Rating of Environmental Noise with Respect to Annoyance, and to Speech Communication*
 SANS 10328:2008, *Methods for environmental noise impact assessments*
 ZF Mgcawu District Municipality Integrated Development Plan 2017-2022
 Northern Cape PSDF (2012) Energy Policy
 Kheis Local Municipality By-laws

3.2 International Conventions and Agreements

Relevant environmental and social international conventions and agreements to which South Africa is a party that is applicable to this project are presented in Table 12.

Table 12: Relevant international conventions to which South Africa is a party^{7 8}

Convention	Summary of objectives or relevant conditions	South African Status
Convention on Biological Diversity (29 December 1993)	Develop strategies, plans or programs for conservation and sustainable use of biological diversity or adapt for this purpose existing strategies, plans or programs which shall reflect, inter alia, the measures set out in this Convention.	Party to
United Nations Framework Convention on Climate Change - Kyoto Protocol (23 February 2005)	To further reduce greenhouse gas emissions by enhancing the national programs of developed countries aimed at this goal and by establishing percentage reduction targets for the developed countries and through the clean development mechanism (CDM) (where developed countries can invest in developing country clean technology to offset emissions).	Party to
Montreal Protocol on Substances That Deplete the Ozone Layer (1 January 1989)	Calculated levels of consumption and production of CFCs must not exceed the stipulated thresholds.	Party to
United Nations Convention to Combat Desertification (26 December 1996)	To combat desertification and mitigate the effects of drought through national action programs.	Party to
United Nations Framework Convention on Climate Change (21 March 1994)	Protection of the climate system: Operations must protect the climate system by controlling greenhouse gases not controlled by the Montreal Protocol, which cause climate change through anthropogenic interference with the climate system.	Party to
Stockholm Convention on Persistent Organic Pollutants (POPs) (17 May 2004)	This convention seeks to ban the production and use of persistent organic chemicals but allow the use of some of these banned substances, such as DDT, for vector control.	Party to
The Fourth ACP-EEC Convention 15 December 1989 (Lome)	Control of hazardous and radioactive waste: the operation must be aware that international law emphasizes strict control of hazardous waste and compliance with domestic legislation in this regard. It also seeks to prohibit imports and exports of such substances.	Party to
Convention concerning the Protection of the World Cultural and Natural Heritage 1972 (Paris)	Ensuring the identification, protection, conservation, presentation and transmission to future generations of the cultural and natural heritage	Ratification
Rotterdam Convention on the Prior Informed Consent Procedure for Certain Hazardous Chemicals and Pesticides in International Trade (24 February 2004)	Promote shared responsibility and cooperative efforts among Parties in the international trade of certain hazardous chemicals in order to protect human health and the environment from potential harm	Party to

⁷ Sources: United States Central Intelligence Agency World Fact book (www.cia.gov/library/publications/the-world-factbook/index.html)

⁸ Schlechter, M., & Baxter, B. 2016. Final EIA Report: Proposed 75MW Photovoltaic (PV2) Solar Development on the Remaining Extent of the Farm Bokpoort 390, Northern Cape. Golder Associates. Ref 14/12/16/3/3/2/880.

Convention	Summary of objectives or relevant conditions	South African Status
Paris Agreement adopted on 12 December 2015 at the 21st session of the Conference of the Parties to the United Nations Framework Convention on Climate Change (UNFCCC CoP21)	<p>The Agreement is a comprehensive framework which will guide international efforts to limit greenhouse gas emissions and to meet all the associated challenges posed by climate change.</p> <p>The main objective of the Agreement is to limit the global temperature increase to well below 2 degrees Celsius, while pursuing efforts to limit the increase to 1.5 degrees.</p>	Ratified

3.3 International Standards

3.3.1 International Finance Corporation Performance Standards

ACWA Power is committed to complying with the IFC Performance Standards (PS) on social and environmental sustainability. These were developed by the IFC and were last updated on 1st January 2012.

The PS comprise of eight performance standards as described in Table 13.

Table 13: IFC Performance Standards

Objective	Applicability
<p>PS 1: Assessment and Management of Environmental and Social Risks and Impacts Guidance note on the categorisation of projects during project screening, requirements for institutional capacity and requirements for public consultation and disclosure.</p>	<p>This Basic Assessment Study supported by comprehensive specialist assessments that was assessed as part of the initial investigations for the seven ICE, the respective specialists (Appendix C1 – C8) have provided assessments on the addition of the ICE components which has identified environmental and social risks and impact of the project and provided mitigation measures to enhance positive impacts and minimise negative impacts, where applicable when considering the addition of the ICE component.</p> <p>The impact assessment is consistent with Good International Industry Practices (GIIP) and takes into account the nature, extent, duration, intensity, probability and significance of the identified impacts both before and after mitigation measures (Chapter 7). Cumulative impacts that result from the incremental impacts on areas or resources directly impacted by the project have also been identified and noted in the study (Chapter 7).</p> <p>The EMPr (Appendix E) provides the actions for the management of identified environmental impacts and a detailed outline of the implementation programme. The EMPr provides strategies to be used to address the roles and responsibilities of environmental management personnel on site, and a framework for environmental compliance and monitoring.</p> <p>Extensive engagement has taken place with project affected people for the previously authorised ten PV plants and seven ICE and will also continue for the addition of the two additional ICE components (Chapter 6).</p>

Objective	Applicability
<p>PS 2: Labour and Working Conditions Recognises that the pursuit of economic growth through employment creation and income generation should be accompanied by protection of the fundamental rights of workers, including health and safety. Failure to establish and foster a sound worker-management relationship can undermine worker commitment and retention and can jeopardise a project.</p>	<p>The overall project development (Project DAO) will provide employment opportunities for 100 – 250 people during the construction phase and 20 – 40 people during the operations phase.</p> <p>Prior to development, human resource policies and procedures, working conditions and terms of employment, equal opportunity, retrenchment policy and a formal grievance mechanism must be established to promote the fair treatment, non-discrimination and equal opportunity of workers in line with national employment and labour laws.</p> <p>Further to this, the Developer also has an obligation to provide a safe and healthy work environment for its employees in terms of the Occupational Health and Safety Act (Act No. 85 of 1993).</p>
<p>PS 3: Resource Efficiency and Pollution Prevention Recognises that increased economic activity and urbanisation often generate increased levels of pollution to air, water, and land, and consume finite resources in a manner that may threaten people and the environment at the local, regional, and global levels. More efficient and effective resource use and pollution prevention and greenhouse gas emission avoidance and mitigation technologies enhance the efficiency and sustainability of the project.</p>	<p>South Africa’s reliance on fossil fuels as a primary energy source is well known and coal combustion is the main contributor to carbon dioxide emissions, a greenhouse gas, that has been linked to climate change. The recent RFP by DMRE, specified that the PV plants may not use auxiliary power from the grid and has to be operational for a specific time period at the start up, in anticipation of the operational start up period possibly occurring during unfavourable weather conditions. The ICE does utilise non-renewable sources of fuel, this is expected to be utilised for a limited time period to boost the viability of the project.</p> <p>An Air Quality and Climate Change Assessment (Appendix C4) has been commissioned and the subsequent impacts associated have been assessed with the recommendations and mitigation measure being incorporated in the BAR and the EMPr (Appendix E) to mitigate all impacts as effectively as possible.</p> <p>Pollution prevention measures contained in this report and EMPr (Appendix E) are in line with GIIP and contain comprehensive management outcomes and impact management actions for waste generation during the different project phases as well as the storage and use of hazardous substances as well as the generations of emissions associated with the ICE that may have a potential to have a detrimental impact on the environment.</p>
<p>PS 4: Community Health, Safety and Security Recognises that project activities, equipment, and infrastructure can increase community exposure to risks and impacts. This Performance Standard addresses the Promotor’ responsibility to avoid or minimise the risks and impacts to community health, safety, and security.</p>	<p>The proposed project will be designed, constructed, operated and decommissioned in accordance with GIIP. Mitigation measures and controls are provided in the EMPr (Appendix E) for spills, incidents and pollution control as well as for containment losses of hazardous substances and generation of emissions associated with the ICE. An Emergency Preparedness and Response Plan must be compiled by the Developer for the project prior to implementation.</p> <p>Traffic and dust impacts have been assessed as being moderate prior to the implementation of mitigation measures and have to be carefully managed as these impacts have been documented during the stakeholder engagement process as being major safety and nuisance factors.</p>

Objective	Applicability
	<p>An adequate resolution needs to be obtained regarding the upgrading (re-gravelling, surfacing etc.) of existing roads and intersections in the study area. A separate environmental process has been initiated and under review for the road.</p>
<p>PS 5: Land Acquisition and Involuntary Resettlement Recognises that project-related land acquisition and restrictions on land use can have adverse impacts on communities and persons that use this land. Involuntary resettlement refers both to physical displacement (relocation or loss of shelter) and to economic displacement (loss of assets or access to assets that leads to loss of income sources or other means of livelihood) as a result of project-related land acquisition and/or restrictions on land use, while temporary or permanent.</p>	<p>No physical or economic displacement and resettlement of people will take place. In terms of land acquisition, the study area is owned by ACWA Power SolAfrica Bokpoort CSP Power Plant (Pty) Ltd (RF).</p>
<p>PS 6: Biodiversity Conservation and Sustainable Management of Living Natural Resources Recognises that protecting and conserving biodiversity, maintaining ecosystem services, and sustainably managing living natural resources are fundamental to sustainable development.</p>	<p>The project will not impact any proclaimed protected biodiversity area.</p> <p>The initial assessment⁹ of the critical habitats have shown that apart from the rocky outcrop to the north of the study area associated with the Koranna-Langeberg Mountain Bushveld Vegetation type which is classified as a Natural Habitat, the calcareous low shrub plains, open shrub plains, open shrub duneveld and transformed areas are classified as Modified Habitats. This rocky outcrop is not affected by the proposed project.</p> <p>The Biodiversity Assessment (Appendix C2) was compiled with impacts managed in line with the mitigation hierarchy. No impacts were identified that could not be mitigated to an acceptable level. Mitigation measures associated with the protection of fauna and flora and management of alien invasive species have been included in the EMPr (Appendix E).</p> <p>The Ecological Walkthrough recommended that it is not feasible to remove or relocate tree species found in the study area e.g. <i>Boscia albitrunca</i>, <i>Vachellia erioloba</i> and <i>V. haematoxylon</i>, thus all trees within the development footprint will be removed and destroyed. Permits will need to be obtained from NCDENC.</p> <p>With respect to the other species of conservation concern (SCC) that occur on site, which are mostly restricted to the calcareous low shrubland, these species could be rescued and relocated to surrounding areas. They could also be used as part of the project's rehabilitation plan, particularly if they can be temporarily housed during the construction phase, thereby reducing the total number of plants that would be lost from site. With respect to relocation, it is very important that the relocation</p>

⁹ Bathusi Environmental Consulting cc.2019. Ecological Basic Impact Assessment of the proposed 200MW Solar Power Development that will be situated on the Remaining Extent of Farm Bokpoort 390 within the !Kheis Local Municipality.

Objective	Applicability
	<p>sites are thoroughly investigated, to prevent the relocation sites being disturbed through the artificial addition of plant species. It is not practical to assume that all the species can be rescued and relocated particularly where large amounts of plants are present, such as the in the case of the <i>Acanthopsis hoffmannseggiana</i> and the <i>Aloe claviflora</i>, under these circumstances its best to try and rescue what is practical. These species are well represented in the surrounding area thus indicating that the loss from site would not result in a loss of the species from the immediate area. The <i>Euphobia davyi</i> and <i>Hoodia gordonii</i> should be removed and relocated.</p> <p><u>A Biodiversity Offset Feasibility Investigation has been considered for the entire project inclusive of the PV plants, ICE and other infrastructure on the Bokpoort farm – Appendix G.</u></p>
<p>PS 7: Indigenous Peoples Recognises that Indigenous Peoples, as social groups with identities that are distinct from mainstream groups in national societies, are often among the most marginalised and vulnerable segments of the population. In many cases, their economic, social, and legal status limits their capacity to defend their rights to, and interests in, lands and natural and cultural resources, and may restrict their ability to participate in and benefit from development.</p>	<p>The Socio-economic study^{10 11 12} confirmed that there is no evidence of the presence of any indigenous people residing or utilising the project area and immediate surrounds.</p>
<p>PS 8: Cultural Heritage Recognises the importance of cultural heritage for current and future generations. Consistent with the Convention Concerning the Protection of the World Cultural and Natural Heritage, this Performance Standard aims to ensure that protect cultural heritage in the course of their project activities.</p>	<p>A comprehensive Heritage Impact Assessment¹³ (Appendix C6) and Desktop Palaeontology Impact Assessment¹⁴ (PIA) together with Chance Find Protocol (Appendix C7) were conducted for the initial assessment for the previously authorised PV Plants, the addition of the ICE component has not resulted in any changes the assessment of impacts and therefore the finding are still applicable to this BAR.</p> <p>No sites, features or objects of cultural significance are known to exist in the development area, there would be no impact as a result of the proposed development. Should archaeological sites or graves be exposed in other areas during construction work, measures and controls have been stipulated in this report and EMPr (Appendix D) for the management of the site/ graves.</p> <p>No significant fossil heritage resources have been recorded within the study area. The area is inferred to be of low sensitivity in terms of palaeontological heritage and no sensitive or no-go</p>

¹⁰ Smith, T; de Waal, D. 2016. Socio-economic Impact Assessment for the proposed 75 MW Photovoltaic (PV1) Solar Facility (Bokpoort II Solar Development). Report No 1400951-302448-18.

¹¹ Smith, T; de Waal, D. 2016. Socio-economic Impact Assessment for the proposed 75 MW Photovoltaic (PV2) Solar Facility (Bokpoort II Solar Development). Report No 1400951-303533-1.

¹² Smith, T; de Waal, D. 2016. Socio-economic Impact Assessment for the proposed 150 MW CSP Tower Facility (Bokpoort II Solar Development) on the Remaining Extent of the Farm Bokpoort 390, Northern Cape. Report No 1400951-299899-7.

¹³ Van Schalkwyk, J.A. 2020. Phase 1 Cultural Heritage Impact Assessment: The Proposed Bokpoort II PV Solar Power Facilities on the Farm Bokpoort 390 near Groblershoop, !Kheis Local Municipality, Northern Cape Province

¹⁴ Almond, J.E. 2020. Proposed Bokpoort II Solar Power Facility on the Remaining Extent of Farm Bokpoort 390 near Groblershoop, Northern Cape Province. Palaeontological impact assessment: desktop study, 17 pp. Natura Viva cc, Cape Town.

Objective	Applicability
	areas have been identified within it during the desktop PIA. In the case of any significant chance fossil finds during construction (e.g. vertebrate teeth, bones, burrows, petrified wood, shells), these must be safeguarded - preferably in situ - and reported as soon as possible to the South African Heritage Resources Agency (SAHRA).

3.4 Equator Principles

The Equator Principles (EPs) is a risk management framework, adopted by financial institutions, for determining, assessing and managing environmental and social risk in projects and is primarily intended to provide a minimum standard for due diligence and monitoring to support responsible risk decision-making.

Project finance is often used to fund the development and construction of major infrastructure and industrial projects.

The EPs are adopted by financial institutions and are applied where total project capital costs exceed US\$10 million. The EPs are primarily intended to provide a minimum standard for due diligence to support responsible risk decision-making. The EPs are based on the IFC PS 2012 and on the World Bank Group Environmental, Health and Safety Guidelines (EHS Guidelines).

The Equator Principles Financial Institutions (EPFIs) have consequently adopted these Principles in order to ensure that the projects they finance are developed in a manner that is socially responsible and reflect sound environmental management practices.

EPFIs will only provide loans to projects that conform to the following principles:

- Principle 1: Review and Categorisation;
- Principle 2: Social and Environmental Assessment;
- Principle 3: Applicable Social and Environmental Standards;
- Principle 4: Action plan and Management;
- Principle 5: Consultation and Disclosure;
- Principle 6: Grievance Mechanism;
- Principle 7: Independent review;
- Principle 8: Covenants;
- Principle 9: Independent Monitoring and Reporting; and
- Principle 10: EPFI Reporting.

The proposed project is a Category B project with potential limited adverse environmental or social risks and/ or impacts that are few in number, generally site-specific, largely reversible, and readily addressed through mitigation measures.

3.4.1 The World Bank Group Environmental Health and Safety (EHS) Guidelines

The EHS Guidelines (World Bank Group, 2007) are technical reference documents with general and industry specific examples of Good International Industry Practice (GIIP). Reference to the EHS guidelines is required under IFC PS 3.

The EHS Guidelines contain the performance levels and measures normally acceptable to the IFC and are generally considered to be achievable in new facilities at reasonable cost. When host country regulations

differ from the levels and measures presented in the EHS Guidelines, projects are expected to achieve whichever standard is more stringent.

3.5 Sustainable Development Goals

The Sustainable Development Goals (SDGs), also known as the Global Goals, were adopted by all United Nations Member States in 2015 as a universal call to action to end poverty, protect the planet and ensure that all people enjoy peace and prosperity by 2030. South Africa has embraced sustainable development as its development approach and is fully committed to the 2030 Agenda for Sustainable Development, its principles, goals, targets and indicators.

The 17 SDGs recognise that action in one area will affect outcomes in others, and that development must balance social, economic and environmental sustainability.



Figure 7: Sustainable Development Goals

SDG 7 requires Affordable and Clean Energy for all. Investing in solar, wind and thermal power, improving energy productivity, and ensuring energy for all is vital if we are to achieve SDG 7 by 2030. Expanding infrastructure and upgrading technology to provide clean and more efficient energy in all countries will encourage growth and help the environment¹⁵.

SDG 13 advocates taking urgent action to combat climate change and its impacts. The Paris Agreement is universally regarded as a seminal point in the development of the international climate change regime under the UNFCCC. The main objective of the Agreement is to limit the global temperature increase to well below 2 degrees Celsius, while pursuing efforts to limit the increase to 1.5 degrees. The recognition of the 1.5 degree target is of central importance to South Africa as an African and developing country that is highly vulnerable to climate change.

¹⁵ <https://sustainabledevelopment.un.org/sdg7>

4 PROJECT ALTERNATIVES

In terms of the EIA Regulations 2014 (as amended) feasible alternatives are required to be considered as part of the environmental investigations. In addition, the obligation that alternatives are investigated is also a requirement of Section 24(4) of the NEMA (Act No. 107 of 1998) (as amended).

An alternative in relation to a proposed activity refers to the different means of meeting the general purpose and requirements of the activity which may include alternatives to:

- the property on which or location where it is proposed to undertake the activity;
- the type of activity to be undertaken;
- the design or layout of the activity;
- the technology to be used in the activity;
- the operational aspects of the activity; and
- the option of not implementing the activity.

4.1 Site Alternatives

No site alternatives have been assessed for the development of the ICE as the position of the ICE, has been optimised through the layout revision.

4.2 Fuel Alternatives

The previous draft cBAR considered Liquefied Petroleum Gas (LPG) or Liquefied Natural Gas (LNG) in the generators, however, this option is no longer feasible.

4.3 No-Go Alternative

The No-Go alternative is the option of not establishing new ICE at the identified sites in the Northern Cape Province. With an increasing demand in energy predicted and growing environmental concerns about fossil fuel-based energy systems, the development of large-scale renewable energy supply schemes such as PV is strategically important for increasing the diversity of domestic energy supplies and avoiding energy imports in the country.

A reciprocating ICE will be used for backup, standby or emergency power as per the RMIPPPP dispatchable period requirements. This ICE infrastructure is only a requirement for a duration of 15 days of the reliability run to ensure that the power plant will operate at full contracted capacity, 150MW. Additional starts and stops within the period will take place for 2 hours per week for the duration of the power plant life cycle. Failure to achieve the reliability run, will result in the plant being rejected and not achieving the commercial operation date with the risk that the PPA can be terminated.

Without the implementation of this project, the use of renewable options for power supply will be compromised in the future. This has potentially significant negative impacts on environmental and social well-being.

Therefore, the No-Go option is not considered as a feasible option on this proposed project.

5 DESCRIPTION OF THE BASELINE ENVIRONMENT

The following section describes the biophysical and socio-economic environment that may be affected by the proposed development of the two ICE. The baseline studies for the authorised Bokpoort I project, for a concentrated solar thermal power plant project¹⁶, and more detailed studies^{17 18 19} focussing on significant environmental aspects of the proposed development were consulted to describe the baseline conditions.

5.1 Geology

The geology of the area is generally characterised by metamorphosed sediments and volcanics intruded by granites and is known as the Namaqualand Metamorphic Province.

Groblershoop is located on the Kalahari Group. The Kalahari Group is divided into four formations. At the base is a soft, clay gravel of fluvial origin (the Wessels Formation). Upon this follows calcareous claystone with interlayered gravel (the Budin Formation). This is in turn overlain by clay-containing, calcareous sandstone (the Eden Formation). Upon the Eden Formation follows the aeolian surface which is characteristic of the group (the Gordonia Formation)²⁰. The proposed solar development project site is situated on red-brown windblown sands of the Gordonia Formation, Kalahari Group.

The general geology of the site mainly comprises red-brown, coarse grained granite gneiss and quartz-muscovite schist, quartzite, quartz-amphibole schist and greenstones of the Groblershoop formation, Brulpan group. Calcrete is also present, especially in the south-eastern part of the area (Figure 8).

Dune ridges occur in the northern portions of the site and are characterised by NNW-SSE orientation. Calcrete outcrops occur approximately 2 km west and southwest from the Garona Substation. An anticlinal structure (upward pointing fold) causes the Groblersdal formation to be elevated in the area to the east of the site where it forms a range of hills known as the Skurweberge.

¹⁶ Benedek, F; Roods, M. 2011. *Environmental Impact Assessment for a Proposed 75MW Concentrating Solar Thermal Power Plant and Associated Infrastructure in the Siyanda District, Northern Cape*. Bohlweki SSI Environmental. DEA Reference number: 12/12/20/1920.

¹⁷ Schlechter, M., & Baxter, B. 2016. *Final EIA Report: Proposed 150MW CSP Tower Development on the Remaining Extent of the Farm Bokpoort 390, Northern Cape*. Golder Associates. Ref 14/12/16/3/3/2/879.

¹⁸ Royal HaskoningDHV. 2020. *Proposed 200MW Ndebele and Xhosa Photovoltaic Plant Developments and Associated Battery Energy Storage System on the Remaining Extent of the Farm Bokpoort 390 near Groblershoop with the !Kheis Local Municipality in the Northern Cape Province*. Final Basic Assessment Report. Ref 14/12/16/3/3/1/2148 and Ref 14/12/16/3/3/1/2149

¹⁹ Royal HaskoningDHV. 2020. *Basic Assessment for the Proposed Development of Eight 200MW Photovoltaic (PV) Plants on the Remaining Extent of Farm Bokpoort 390, Groblershoop, Northern Cape*. Final Consultation Basic Assessment Report. Ref 14/12/16/3/3/1/2142, 2143, 2144, 2145, 2146, 2147, 2150, 2151

²⁰ Council for Geoscience. 2016. *Simplified Geology of the Northern Cape Province*. Retrieved January 26, 2016, from Council for Geoscience: www.geoscience.org.za

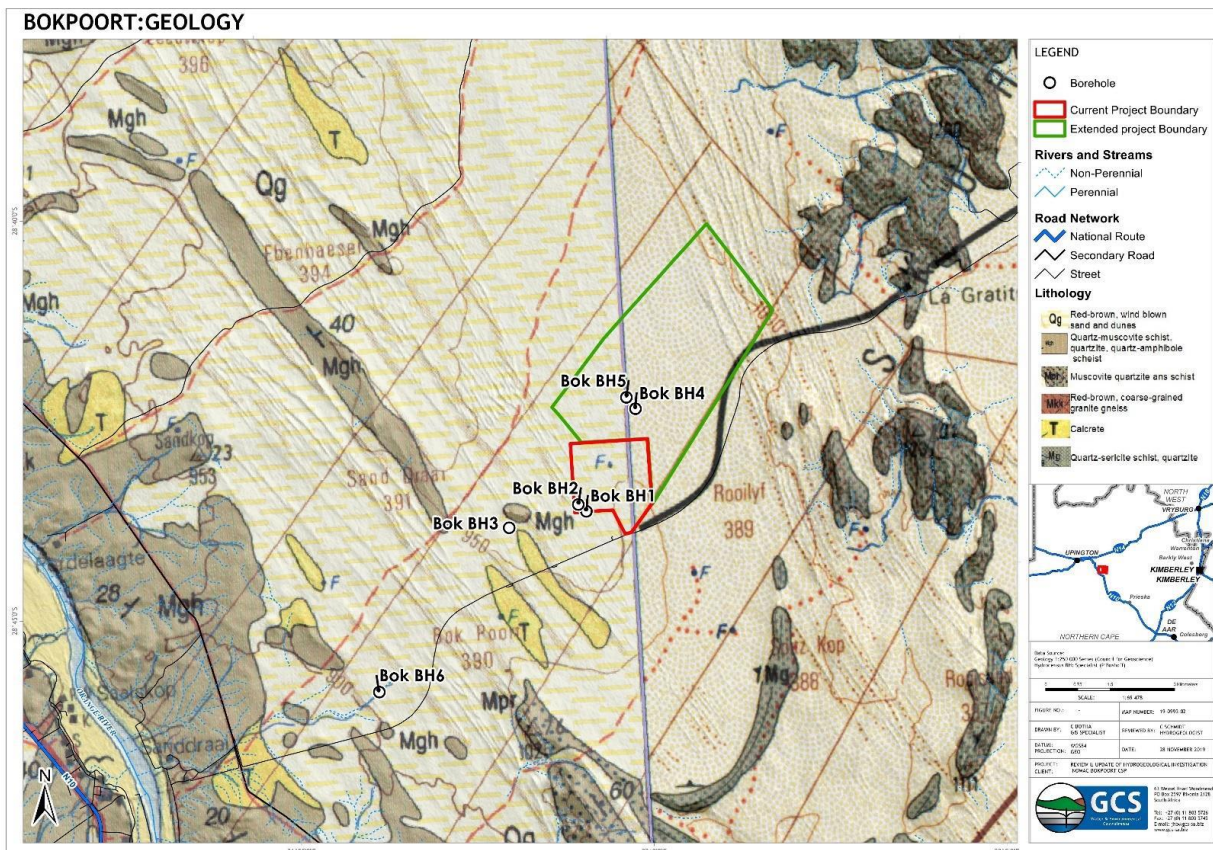

Figure 8: Geology map

5.2 Meteorological Conditions

5.2.1 Rainfall and Water Availability

Rainfall in the project area is scarce and generally occurs in late summer and early autumn between January and April (Figure 9). Average rainfall in the area varies between 170 and 240mm per annum (Figure 10), while evaporation is extremely high, due to the high temperatures, which can reach 35 - 40°C in summer.

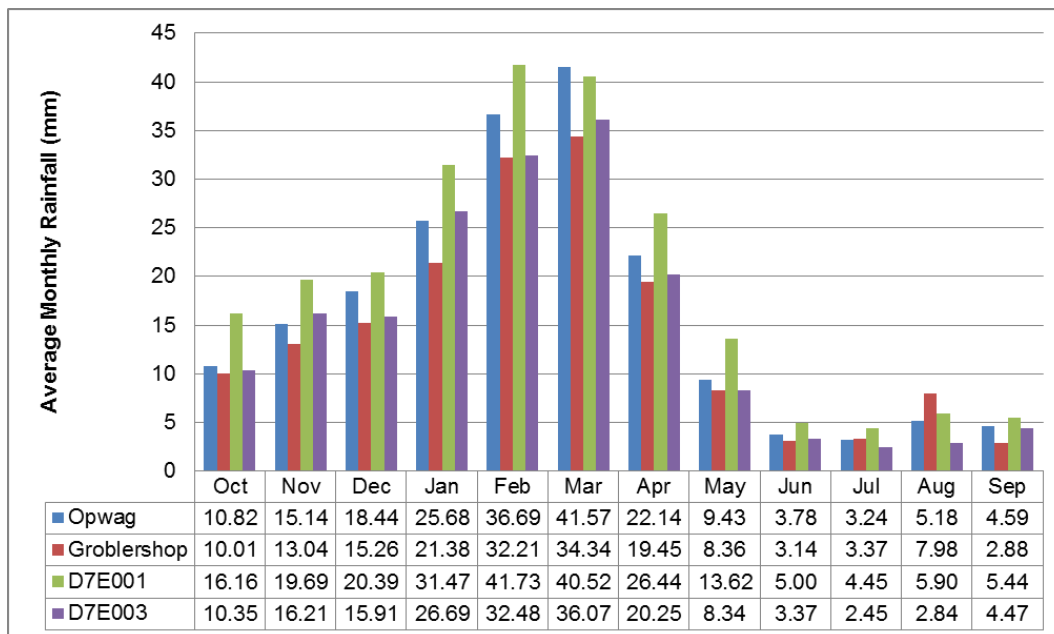

Figure 9: Monthly rainfall distribution for rainfall stations in the surrounding area²¹

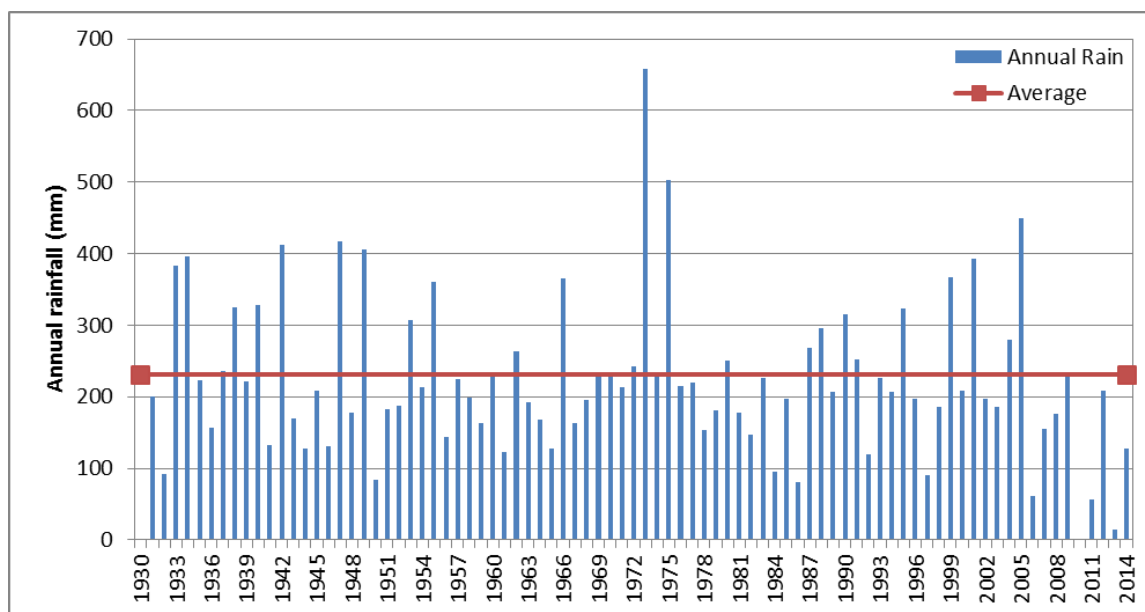

Figure 10: Annual rainfall recorded at the D7E001 (Boegoeberg Dam) station²²

One of the most important climate parameters for agriculture in a South African context is moisture availability, which is the ratio of rainfall to evapotranspiration. Moisture availability is classified into 6 categories across the country (Table 14). The site falls into the driest of these six categories (C6), which is labelled as a very severe limitation to agriculture.

²¹ Schlechter, M., & Baxter, B. 2016. Final EIA Report: Proposed 150MW CSP Tower Development on the Remaining Extent of the Farm Bokpoort 390, Northern Cape. Golder Associates. Ref 14/12/16/3/2/879.

²² Ibid.

Table 14: The classification of moisture availability climate classes for summer rainfall areas across South Africa*

Climate class	Moisture availability (Rainfall/ 0.25 PET)	Description of agricultural limitation
C1	>34	None to slight
C2	27-34	Slight
C3	19-26	Moderate
C4	12-18	Moderate to severe
C5	6-12	Severe
C6	<6	Very severe

*Source: Agricultural Research Council

5.2.2 Evaporation

Monthly evaporation data was available for the DWS Station D7E001, located approximately 40km south east of the project site. The station has an approximate Mean Annual Evaporation (MAE) of 2166.3mm calculated over a period of 1931 - 2008. Monthly mean, minimum and maximum evaporation depths are shown in Figure 11.

The highest evaporation occurs in the summer months of September to March. The average monthly evaporation values are shown in Table 15.

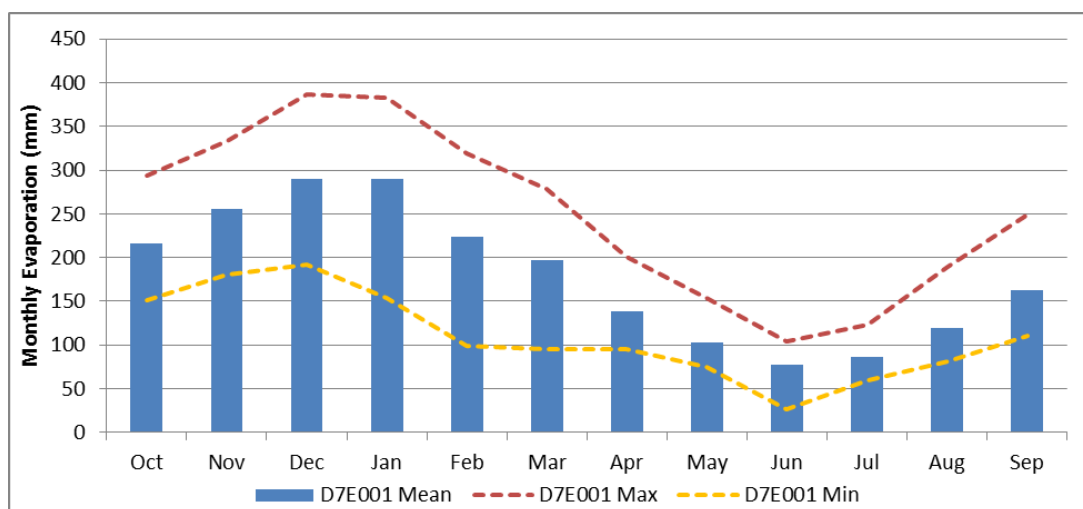

Figure 11: Monthly mean, minimum and maximum evaporation for station D7E001 (Boegoeberg Dam)²³

²³ Schlechter, M., & Baxter, B. 2016. Final EIA Report: Proposed 150MW CSP Tower Development on the Remaining Extent of the Farm Bokpoort 390, Northern Cape. Golder Associates. Ref 14/12/16/3/3/2/879.

Table 15: Average monthly evaporation values for station D7E001²⁴

Month	Monthly Evaporation
October	216
November	255
December	290
January	290
February	223
March	197
June	139
July	103
August	77
September	87
Year	1 877

5.2.3 Surface Wind Field

The Water Research and Forecasting (WRF) data for the period 2017 to 2019 was utilised for the assessment. The WRF period wind roses (Figure 12) depict the predominance of the north-north-easterly winds with wind speeds greater than 5m/ s, especially during the day. Winds from the north-westerly sector were also predominant during the day, albeit at slightly lower overall wind speed. The night-time wind rose shows a decrease in the northerly and the north-westerly winds and an increase in the easterly and east-south-easterly winds. Night-time was also characterised by an increase in the frequency of calm wind conditions.

Calm conditions were most frequently recorded in summer and most infrequently in winter (Figure 13). In summer, west-south-westerly dominance is noted, while in winter north-north-easterly winds were more frequent. Winds in the higher wind speed categories were most common in spring from the north-north-east.

²⁴ *Ibid.*

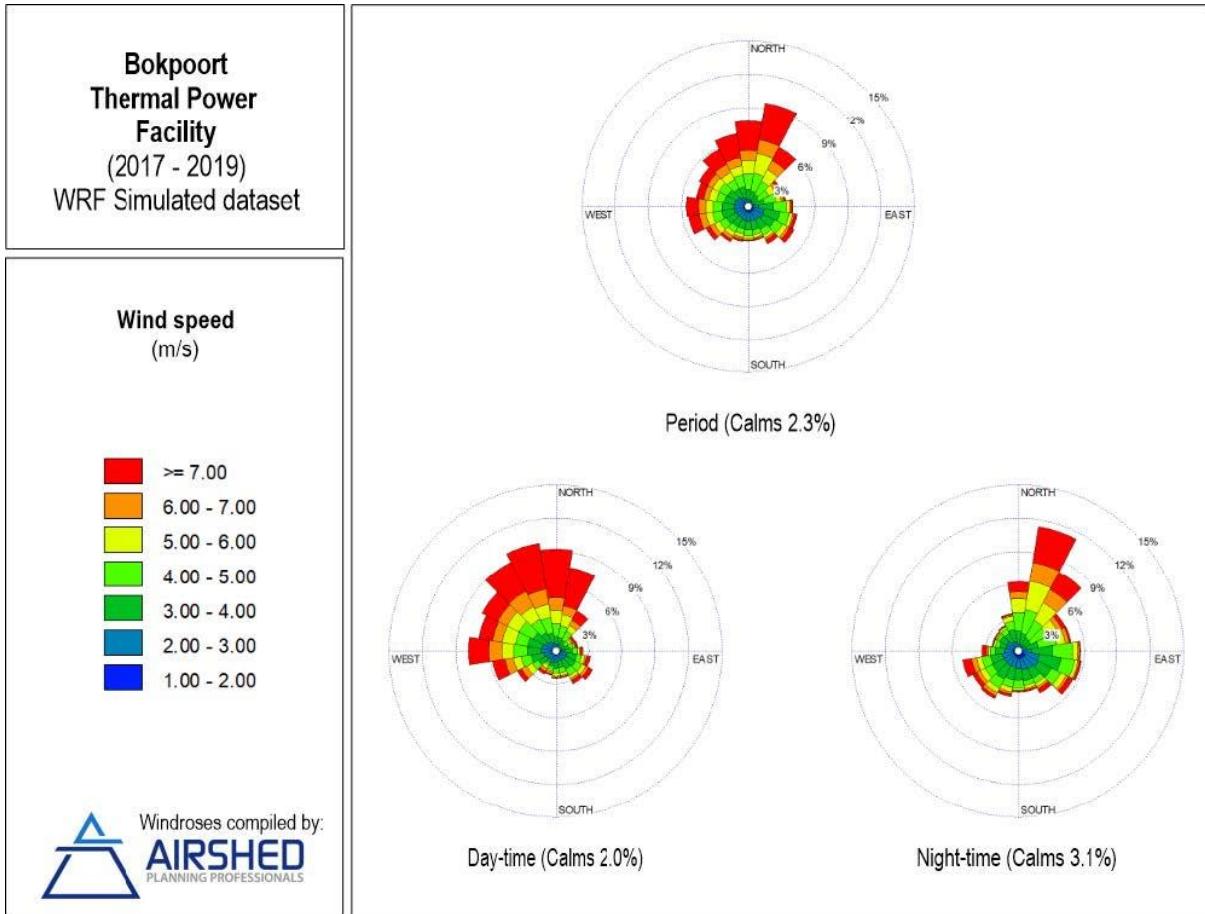

Figure 12: Period average, day-time and night-time wind roses (WRF simulated data; 2017 to 2019)

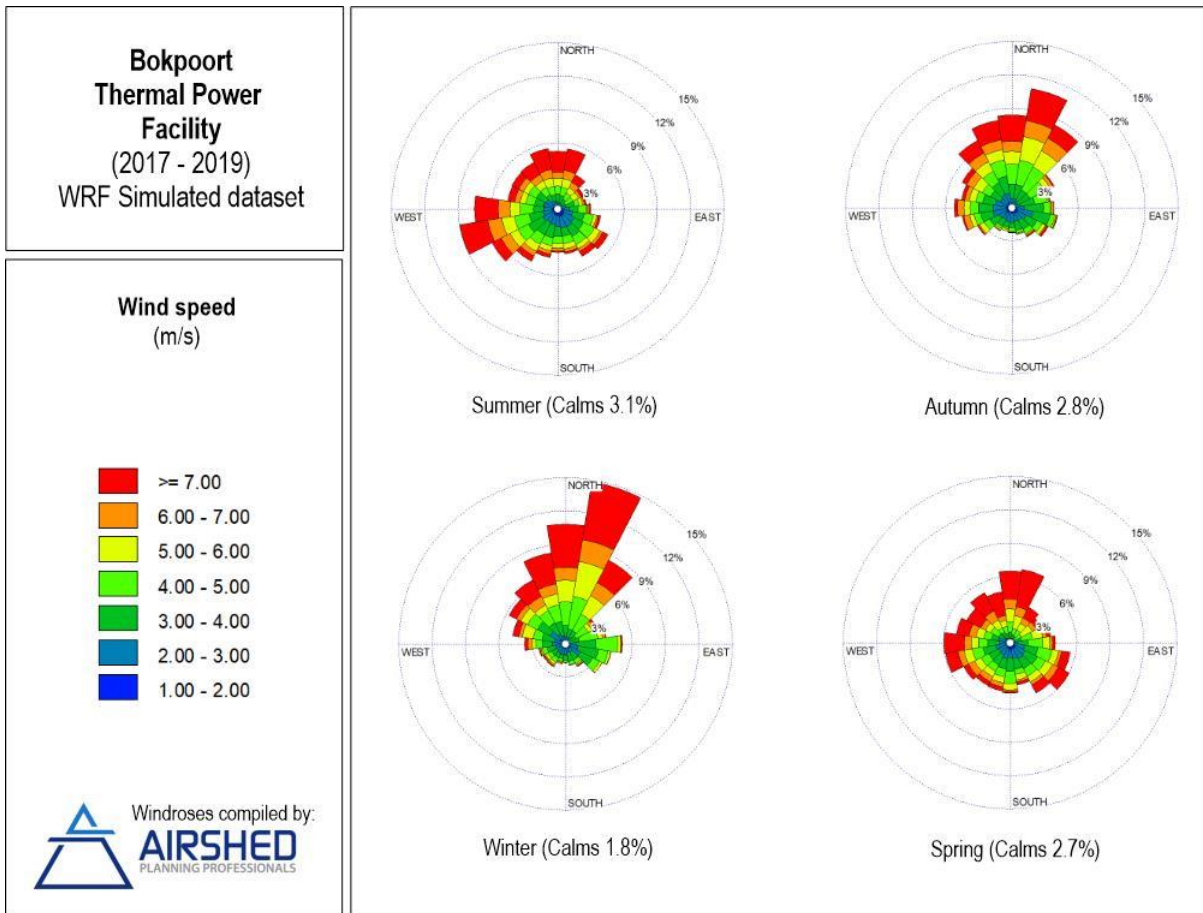

Figure 13: Seasonal wind roses (WRF simulated data; 2017 to 2019)

5.2.4 Temperature

The monthly temperature patterns from the WRF data are shown in Table 16 and Figure 14. Average temperatures ranged between 13.1°C and 25.5°C. The highest temperatures occurred in December and the lowest in July. During the day, temperatures increase to reach maximum at around 15:00 in the afternoon. Ambient air temperature decreases to reach a minimum at around 07:00.

Table 16: Monthly temperature summary (2017 to 2019)

Hourly Minimum, Hourly Maximum and Monthly Average Temperatures (°C)												
Statistics	Jan	Feb	Mar	Apr	May	Jun	Jul	Aug	Sep	Oct	Nov	Dec
Minimum	-1.3	-1.8	-2.5	-2.8	-3.1	-3.6	-3.8	-2.5	2.8	4.4	6.4	7.9
Average	17.0	15.2	14.6	14.0	13.5	13.1	14.3	17.0	19.9	22.3	24.0	25.5
Maximum	31.1	28.1	27.0	27.1	27.2	26.7	29.2	32.3	34.2	35.5	36.8	37.6

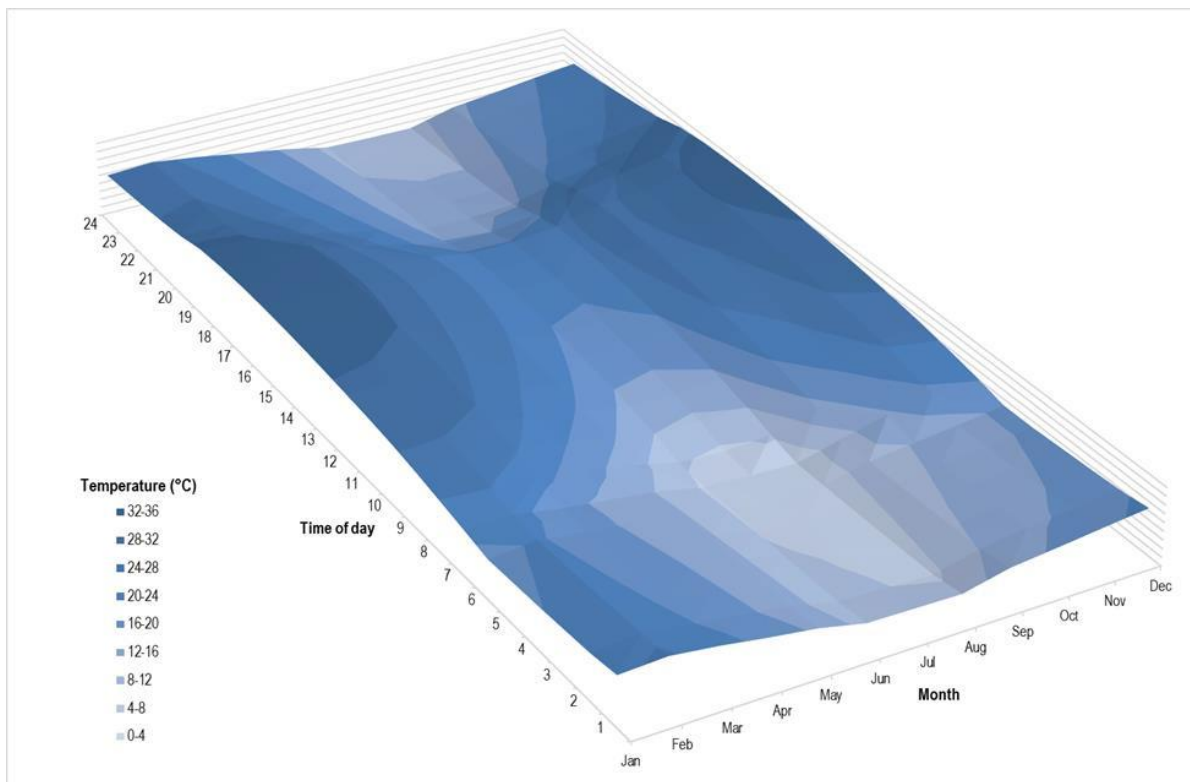

Figure 14: Monthly temperature profile (WRF simulated data, 2017 to 2019)

5.3 Topography

The regional-scale study area (50km radius) is characterised by terrain elevations in the range 800 and 1650m amsl (Figure 15). In closer proximity to the project site, elevations vary between 900 to 1150m amsl with gently undulating terrain with no major topographical features within 10km of the proposed site. The average slope across the study area is less than 10%.

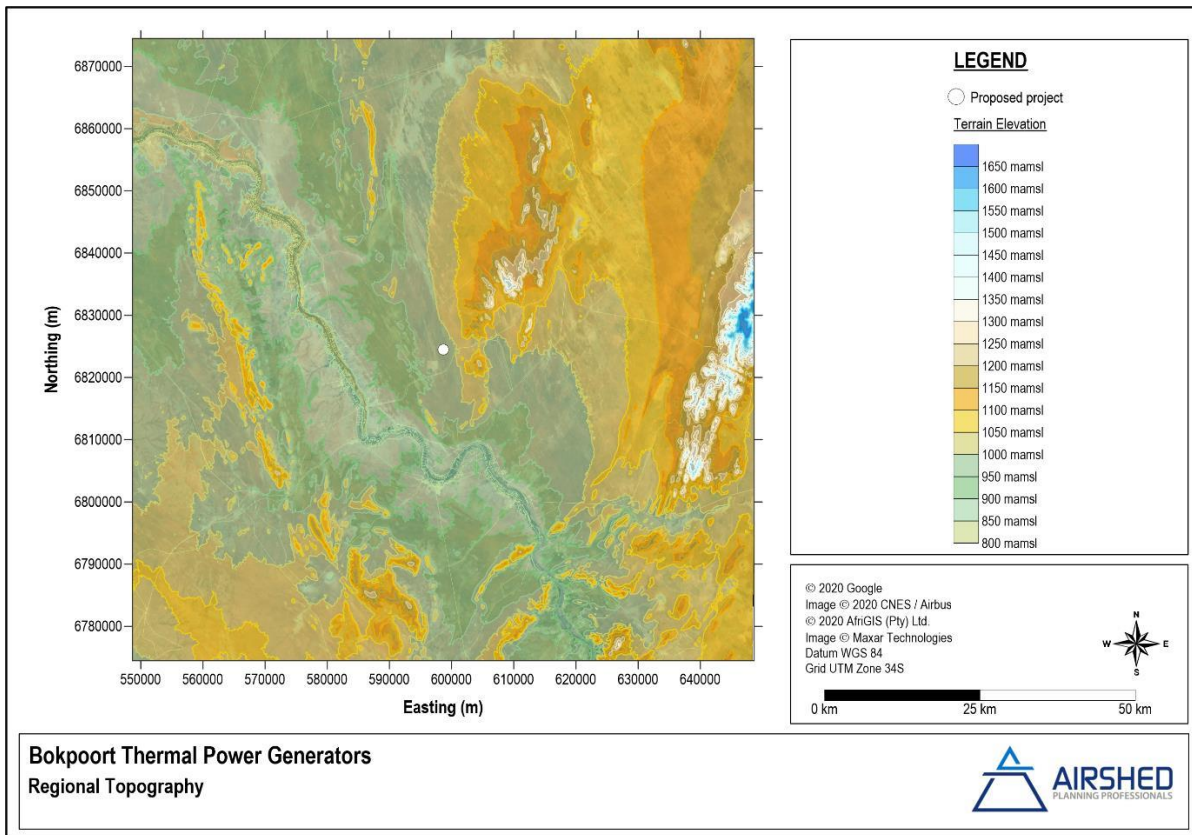

Figure 15: Terrain of the project area

5.4 Soils

The land type classification is a nationwide survey that groups areas of similar soil, terrain and climate conditions into different land types. There is predominantly one land type across most of the site, namely Ae4. A small part of the site in the extreme north east is on land type Af7. The soils of Ae4 are shallow to moderately deep, red, sandy soils overlying hard pan carbonate and sometimes rock. These soils fall into the Calcic and Lithic soil groups according to the classification of Fey²⁵. Land type Af7 comprises deeper red sands and includes dunes. Soils are predominantly of the Coega soil form, with lesser coverage of shallow Plooyburg form. It should be noted that the land type classification presented in Appendix 1 of the Soils and Agricultural Potential Assessment (**Appendix C1**) made use of the older South African soil classification system, which did not include the Coega and Plooyburg forms. These forms would have been classified, according to the older system, as Mispah and Hutton respectively.

The soils are classified as having low to moderate susceptibility to water erosion, and as highly susceptible to wind erosion.

²⁵ Fey, M. 2010. *Soils of South Africa*. Cambridge University Press, Cape Town.

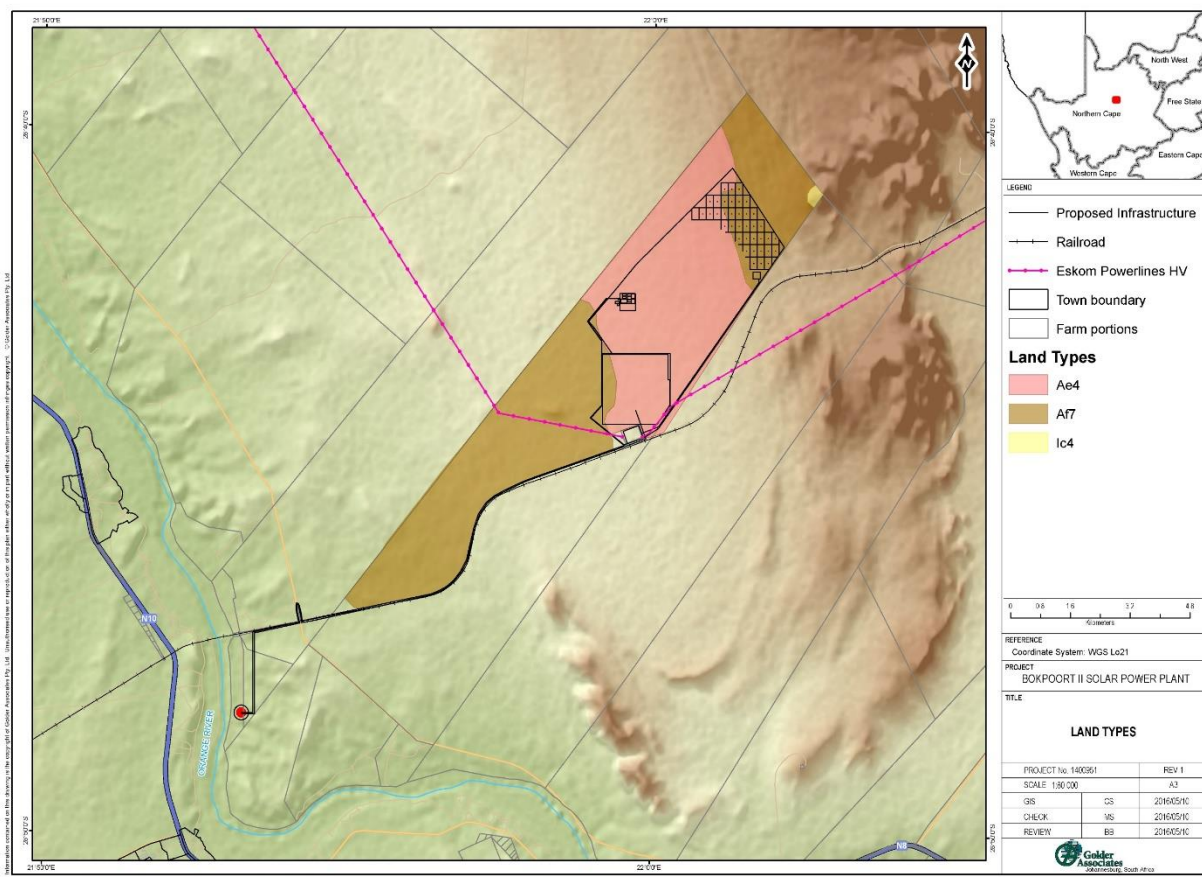

Figure 16: Land types²⁶

5.5 Agricultural Capability

The project area is classified with a predominant land capability evaluation value of 5 (Low), although it varies from 3 (Very Low to Low) to 5 (Low) across the site (Table 17). Agricultural limitations that result in the low land capability classification are predominantly due to the very limited climatic moisture availability. The very sandy soils, with very limited water holding capacity are a further limitation. These factors render the site unsuitable for any kind of mainstream cultivation without irrigation and limit it to low density grazing only.

Table 17: Details of the 2017 Land Capability classification for South Africa

Land capability evaluation value	Description
1	Very Low
2	
3	
4	Very Low to Low
5	
6	Low
7	
8	Low to Moderate
	Moderate

²⁶ Schlechter, M., & Baxter, B. 2016. Final EIA Report: Proposed 75MW Photovoltaic (PV2) Solar Development on the Remaining Extent of the Farm Bokpoort 390, Northern Cape. Golder Associates. Ref 14/12/16/3/3/2/880.

Land capability evaluation value	Description
9	Moderate to High
10	
11	High
12	High to Very High
13	
14	Very High
15	

The long-term grazing capacity of the site is fairly low at 22 hectares per large stock unit.

5.6 Surface Water

The project area is situated in the Lower Orange Main Stem Catchment (116539) and is governed by the Orange Water Management Area (WMA). The catchment is still largely undeveloped with limited water resources and water uses. The project site is situated in the D73D quaternary catchment. The Lower Orange Main Stem catchment area is reflected in Figure 17.

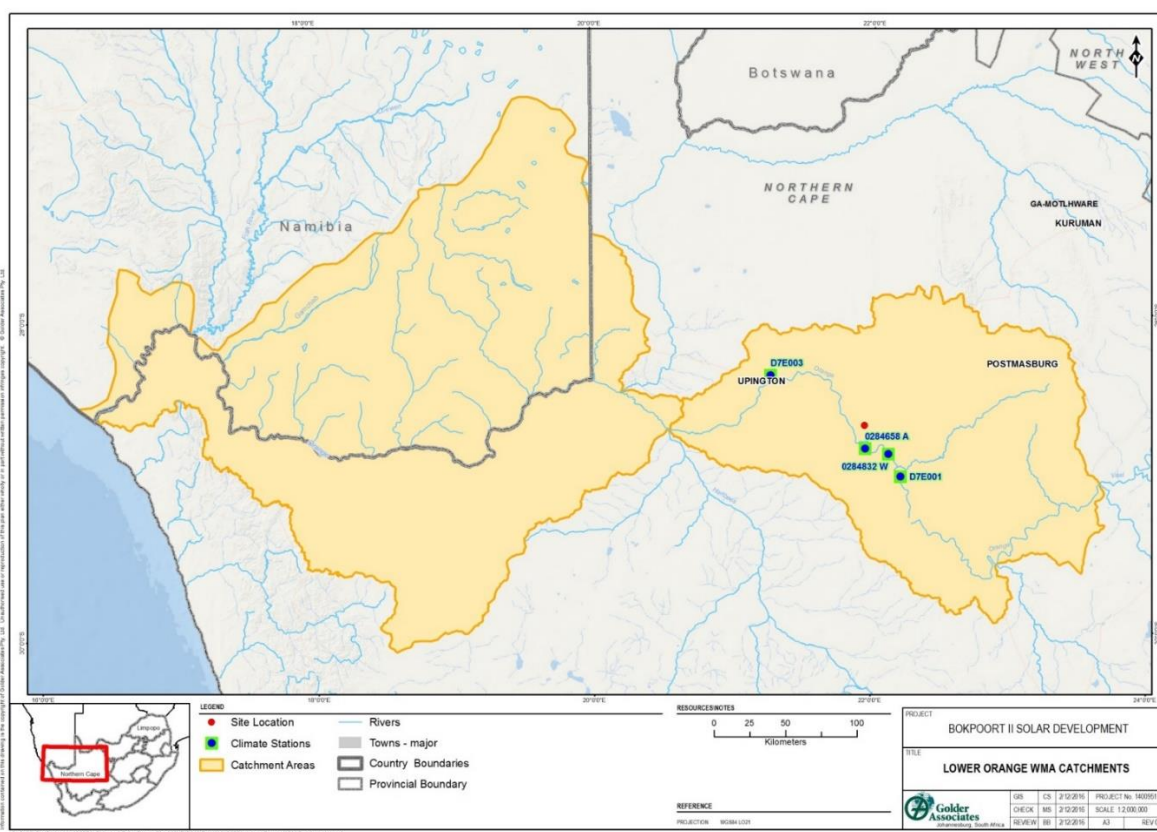

²⁷ Dateling, J; Boyd, L. 2015. 1400951-299955: Surface Water Baseline and Impact Assessment Report for the Proposed 150 MW CSP Tower Facility (Proposed Bokpoort II Solar Development) near Groblershoop, Northern Cape. Midrand: Golder Associates Africa (Pty) Ltd.

5.6.1 Water Quality

There are two DWS monitoring points in the Orange River: D7H8, upstream of the project area and D7H5, downstream of the project at Upington. The water quality at both points is good when compared against the interim Resource Water Quality Objectives (RWQOs) developed as part of the Water Resources Planning project for the Upper and Lower Orange River in 2009. The water is however slightly alkaline and nitrate and orthophosphate exceed the limits set which would lead to eutrophication in the river.

The water quality requirement for the proposed project may however be stricter than that abstracted so that some kind of treatment may still be needed.

Table 18: Water quality in the Orange River at DWS monitoring points compared against the interim RWQOs

Parameter	Units	Interim RWQO*	Upstream (D7H8)			Downstream (D7H5)		
pH		7.1-8.4	7.26	8.13	8.55	7.19	8.14	8.45
Electrical Conductivity	mS/m	70	18.47	26.40	47.64	21.10	32.30	55.83
Total Dissolved Solids	mg/L	400	145.00	197.22	317.46	151.95	228.00	374.19
Calcium	mg/L	80	18.50	23.70	33.75	19.24	25.71	35.69
Chloride	mg/L	100	5.00	13.49	40.93	7.68	17.85	48.09
Fluoride	mg/L	0.7	0.12	0.20	0.34	0.16	0.23	0.41
Potassium	mg/L	15	1.26	1.92	4.26	1.40	2.24	4.29
Magnesium	mg/L	30	6.87	9.70	16.89	7.26	11.40	20.67
Sodium	mg/L	70	7.20	13.50	33.44	9.44	18.10	44.14
Ammonia	mg/L	0.015	0.02	0.04	0.12	0.02	0.03	0.11
Nitrate	mg/L	0.2	0.02	0.24	0.67	0.02	0.18	0.81
Orthophosphate	mg/L	0.02	0.01	0.02	0.06	0.01	0.02	0.08
Silica	mg/L	20	3.22	6.80	8.55	2.60	6.71	8.63
Sulphate	mg/L	80	7.21	20.10	59.61	8.60	23.90	64.65
Total Alkalinity	mg/L	300	73.70	92.20	113.76	70.47	104.70	139.27

*the stricter of the RWQOs set at the two points has been chosen

The Orange River's water quality is categorised as Moderately Transformed (Class C) due to existing agricultural activities along the riverbanks. The Orange River's major inflow of water is from the Vaal River which has high nutrient levels which sometimes result in algal blooms. Slow water flow rates also cause siltation and turbidity of the water which leads to water quality degradation within the river.

5.6.2 Surface Water Features at the Farm Bokpoort

Apart from the Orange River, which is a large regional river, drainage is largely limited to the wider Orange River valley, especially in the areas to the north and east of the river (in which the study area is located). Drainage only occurs within an area of about 4.5km of the river channel, an area which is largely characterised by rugged, incised topography. Beyond this corridor no or very limited drainage occurs. Limited surface water drainage occurs in areas characterised by higher-lying, rockier terrain, such as the mountainous terrain (Skurweberg Hills) located to the east and north-east of the site.

The 1:50000 scale topo-cadastral maps indicate that there are no drainage or surface water features on the development site. A site visit confirmed that no surface water features are located on the site of the proposed development. Of the two primary landforms located on the development site, the calcrete gravel plains are extremely flat, with no linear surface water drainage features present. Pans can occur in such very flat terrain where no linear drainage occurs, but there are no pans that occur on the site.

The closest surface water features to the development site are located 900m – 1km to the east and north-east of the development site's north-eastern boundary where the underlying geology changes and a concomitant change in topography from Duneveld to rocky hills is encountered.

5.7 Groundwater

5.7.1 Geology and Hydrogeological Setting

The general geology of the site mainly comprises red-brown, coarse-grained granite gneiss; and quartz-muscovite schists, quartzite, quartz-amphibole schists and greenstones of the Groblershoop formation, Brulpan group. Calcrete is also found especially on the south eastern part of the area.

The aquifer vulnerability and classification maps of South Africa classifies this area as underlain by a least vulnerability, this means that this aquifer is only vulnerable to conservative pollutants in the long term when continuously discharged or leached²⁸. The metamorphic rocks represent fractured aquifer types with a moderately-yielding aquifer system of variable water quality.

5.7.2 Hydrocensus

During the hydrocensus conducted in November 2019, five (5) boreholes were identified within a ~4km radius of the study area and an additional borehole was located approximately 10km from the study area and was included in the hydrocensus. Therefore, in total six (6) hydrocensus boreholes were identified, of which three (3) were accessible for groundwater level measurements. The results of the hydrocensus are summarised in Table 19 and the spatial distribution with respect to the study area is shown in Figure 18. Borehole Bok BH3 previously had a submersible pump installed and was utilized for domestic water supply for farm owner's house and farm village workers but this borehole is now dry. Similarly, borehole Bok BH6 previously had a windmill installed and was utilized for livestock watering but this borehole is now dry. Boreholes Bok BH1 and Bok BH2 are used for monitoring purposes around the evaporation ponds of the operational CSP plant.

²⁸ Department of Water and Sanitation (DWS) (2013). *Aquifer Vulnerability Map of South Africa*.

Table 19: Hydrocensus data collected during November 2019

Locality ID	Latitude	Longitude	Surface Elevation	Borehole Status	Pump Type	Water Use Application	Collar Height	Groundwater Level (mbch)	Groundwater Elevation (m amsl)
Bok BH1	-28.73413	21.98887	960	Monitoring Borehole	-	Other	0.65	27.9	931.45
Bok BH2	-28.73262	21.98705	953	Monitoring Borehole	-	Other	0	25.65	927.35
Bok BH3	-28.73661	21.97039	944	Not Operational	-	-	Dry		
Bok BH4	-28.71334	22.00186	953	Not Equipped	-	-	0.15	38.55	914.3
Bok BH5	-28.71084	21.99989	958	Operational	Windmill	Stock	Not measured		
Bok BH6	-28.76924	21.93739	890	Not Operational	-	-	Dry		

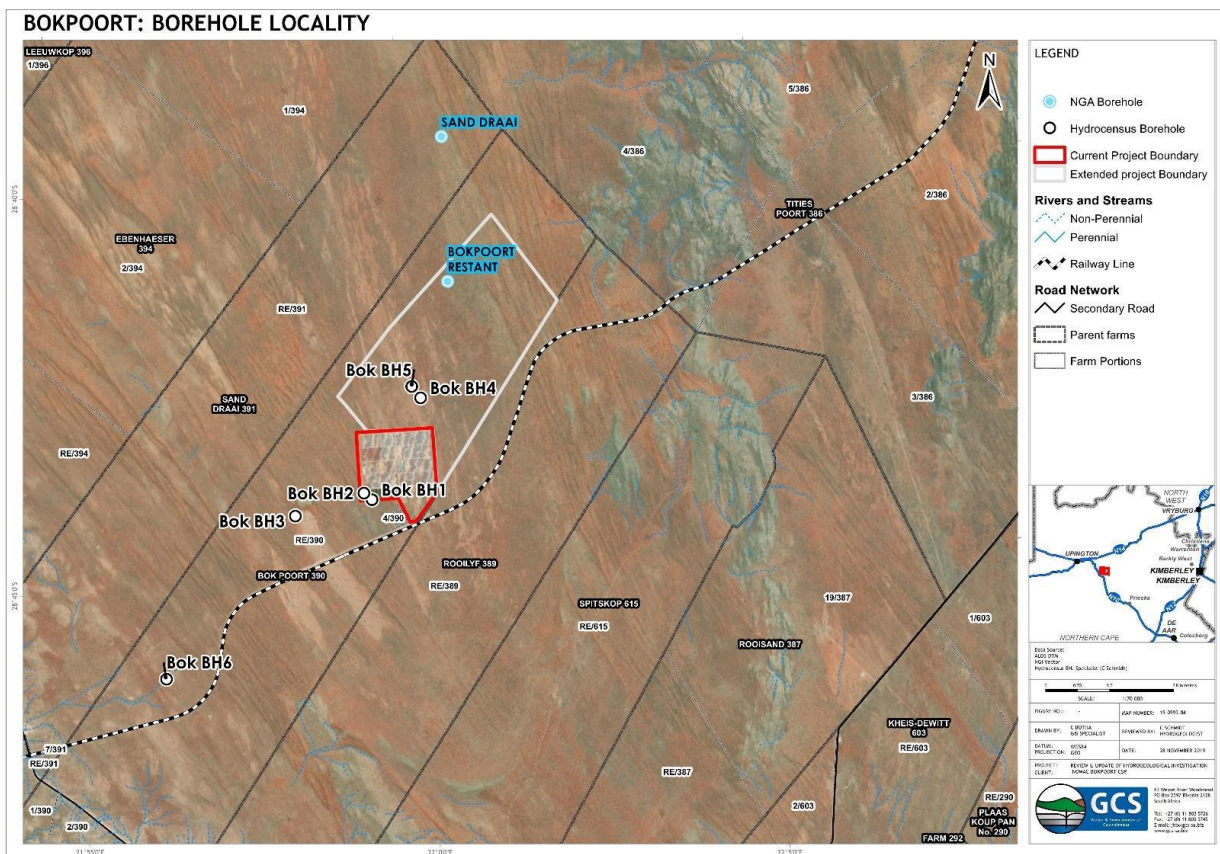

Figure 18: Borehole locality map

The hydrocensus survey in November 2019 indicated that groundwater is mainly used for small-scale livestock watering purposes (goat and sheep farming).

5.7.3 Groundwater Level and Flow

Groundwater elevation recorded during the 2019 hydrocensus survey range between ~914 and ~931m above mean sea level (mamsl), with depth to water varying from ~25m below ground level (m bgl) and ~38m bgl.

From the hydrocensus survey measured water level data, a correlation of ~ 68% exists between the topography and groundwater elevation (Figure 19). The relatively poor correlation is likely depictive of two (2) distinctive aquifer systems (the upper weathered aquifer and the deeper fractured aquifer).

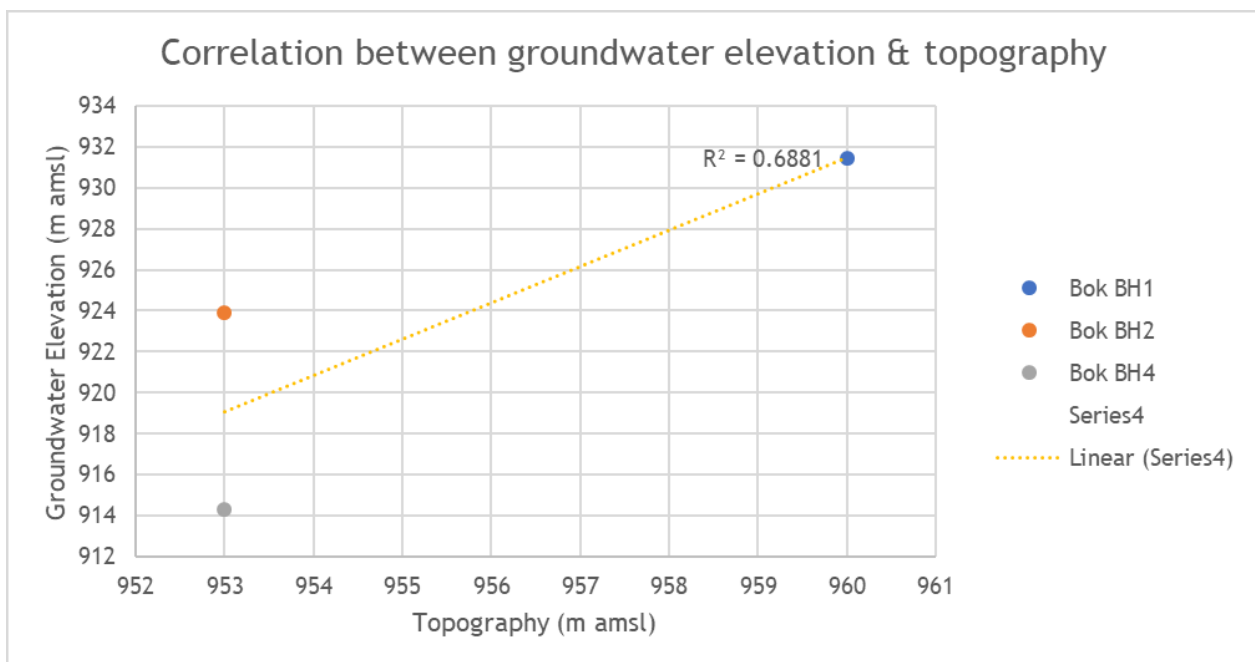

Figure 19: Topography and groundwater head correlation

5.7.4 National Groundwater Archives and National Register of Water Use Databases

The National Groundwater Archive (NGA) and National Register of Water Use (WARMS) was accessed to obtain any existing groundwater data. Within a 5km radius of the study area two (2) boreholes within the NGA were found, however, no registered boreholes on the WARMS database were found. Limited information for the two (2) NGA boreholes is available.

5.7.5 Groundwater Quality

Boreholes Bok BH1 and Bok BH2 indicate water with neutral pH, electrical conductivity (EC) ranging from ~67 to ~105 mS/m, total hardness ranging from hard to very hard and low manganese concentration were recorded. Borehole Bok BH3 indicate very hard water with neutral pH, elevated EC and total dissolved solids (TDS), elevated nitrate concentration and low chromium concentration was recorded.

5.7.6 Hydrogeological Characterisation

The following water types are observed in and surrounding study area (Figure 20):

- Sample sites Bok BH1 and BH2 indicate predominantly Ca-Mg-HCO₃ type water; and
- Sample site Bok BH3 indicate predominantly Ca-Mg-Cl type water.

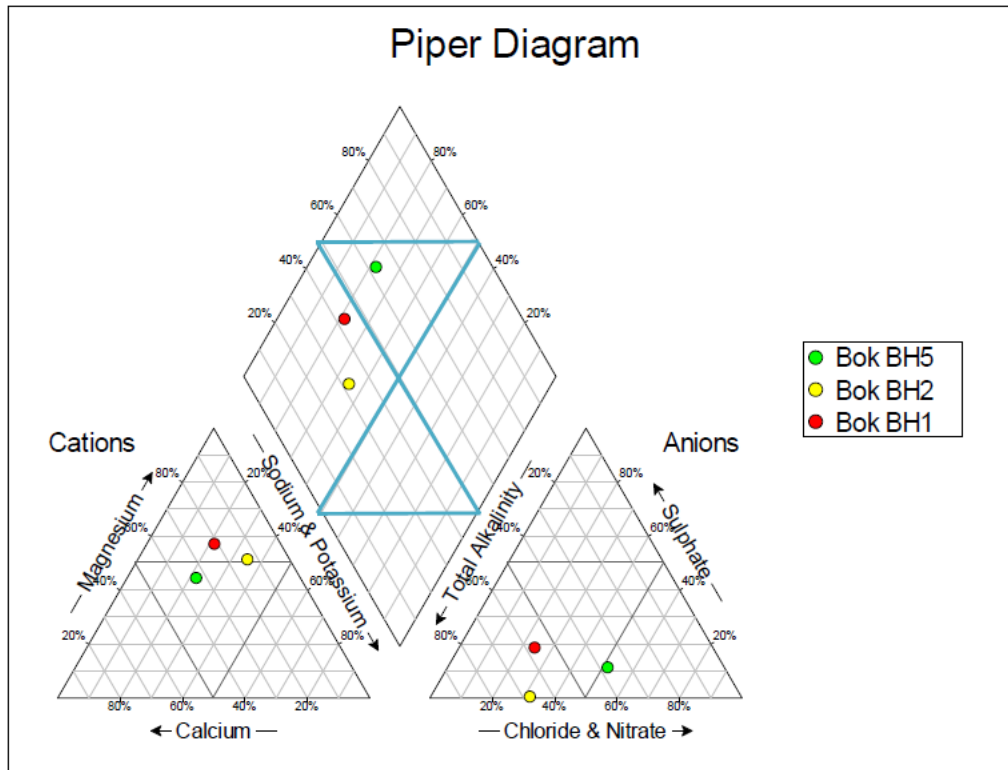

Figure 20: Piper diagram

5.7.7 Groundwater Quality Compared to Water Criteria Guidelines/ Standards

Groundwater in the area is mostly used for livestock watering and is therefore compared to the Department of Water Affairs (DWA) South African Water Quality Guidelines Volume 5 for Livestock Watering Use²⁹. Additionally, the water quality will also be compared to the Department of Water Affairs (DWA) South African Water Quality Guidelines Volume 1 for Domestic Use³⁰ and South African Bureau of Standards (SABS) SANS 241-1:2011 Drinking Water Standards.

Comparison of the groundwater quality to the relevant guidelines is summarized in Table 20 (Livestock Watering Use) and Table 21 (Drinking/ Domestic Use).

Table 20: Livestock watering use compliance and risk status

Sample ID	Compliance Status				Livestock Health Risk Status
	General Parameters	Anions	Nitrogen-species	Cations and metals	
Bok BH1	Yes	Yes	Yes	Yes	None: based on all parameters analysed, the water adheres to SAWQG Target Values for Livestock watering
Bok BH2	Yes	Yes	Yes	Yes	
Bok BH3	Yes	Yes	Yes	Yes	

Note: Red indicates an exceedance of the DWA SAWQG Target Value for Livestock Watering use

²⁹ Department of Water Affairs and Forestry. 1996. South African Water Quality Guidelines (second edition). Volume 4: Agricultural Use: Irrigation.

³⁰ Department of Water Affairs and Forestry. 1996. South African Water Quality Guidelines: Domestic Uses.

Table 21: Drinking/ domestic use compliance and risk status

Sample ID	Compliance Status				Risk Status	
	General Parameters	Anions	Nitrogen-species	Cations and metals	Health	Aesthetic
Bok BH1	No (TDS, turbidity)	Yes	Yes	No (Ca and Mn)	TDS, Ca and Mn: No health effects are likely Turbidity: Water carries an associated risk of disease due to infectious disease agents and chemicals adsorbed onto particulate matter	TDS: Water has a noticeable salty taste but is well tolerated No effects on plumbing or appliances Turbidity: Severe aesthetic effects (appearance, taste and odour) Ca: No health effects. Increased scaling problems Lathering of soap impaired Mn: Threshold for significant staining and taste problems
Bok BH2	No (turbidity)	Yes	Yes	No (Mn)	Mn: No health effects are likely Turbidity: Water carries an associated risk of disease due to infectious disease agents and chemicals adsorbed onto particulate matter	Mn: Increasingly severe staining and taste problems. Turbidity: Severe aesthetic effects (appearance, taste and odour)
Bok BH3	No (EC, TDS and turbidity)	No (Cl)	No (Nitrate as N and as NO ₃)	No (Ca and total Cr)	TDS/EC: Consumption of water does not appear to produce adverse health effects in the short-term Turbidity: Water carries an associated risk of disease due to infectious disease agents and chemicals adsorbed onto particulate matter Cl and Ca: No health effects Nitrate as N: Methaemoglobinaemia occurs in infants. Occurrence of mucous membrane irritation in adults Cr: Danger of kidney damage with long-term exposure. Brief exposure, for less than one week should not cause any noticeable damage. Exposure should not exceed one week	TDS/EC: Water has a marked, salty taste and some effects on plumbing and appliances, such as increased corrosion or scaling, may be expected Turbidity: Severe aesthetic effects (appearance, taste and odour) Cl: Water has a distinctly salty taste. Likelihood of noticeable increase in corrosion rates in domestic appliances Ca: Severe scaling problems. Lathering of soap severely impaired

Note: Red indicates an exceedance of the SANS 241:2011 and/ or DWA SAWQG Target Value for Domestic Use

5.8 Ecology

Two principal natural vegetation types are predicted for the study area³¹, namely Kalahari Karroid Shrubland comprising the largest extent of the site and Gordonia Duneveld that is situated in the northern part of the site (Figure 21).

The Kalahari Karroid Shrubland vegetation type occurs in the Northern Cape Province, forming part of the Nama Karoo Biome (Bushmanland Bioregion). The vegetation and landscape features are typically low karroid shrubland on flat, gravel plains. The conservation status is Least Threatened.

Gordonia Duneveld is part of the Savanna Biome (Kalahari Duneveld Bioregion), with vegetation and landscape features comprising characteristically parallel dunes about 3 – 8m above the plains. The conservation status of this unit is regarded Least Threatened.

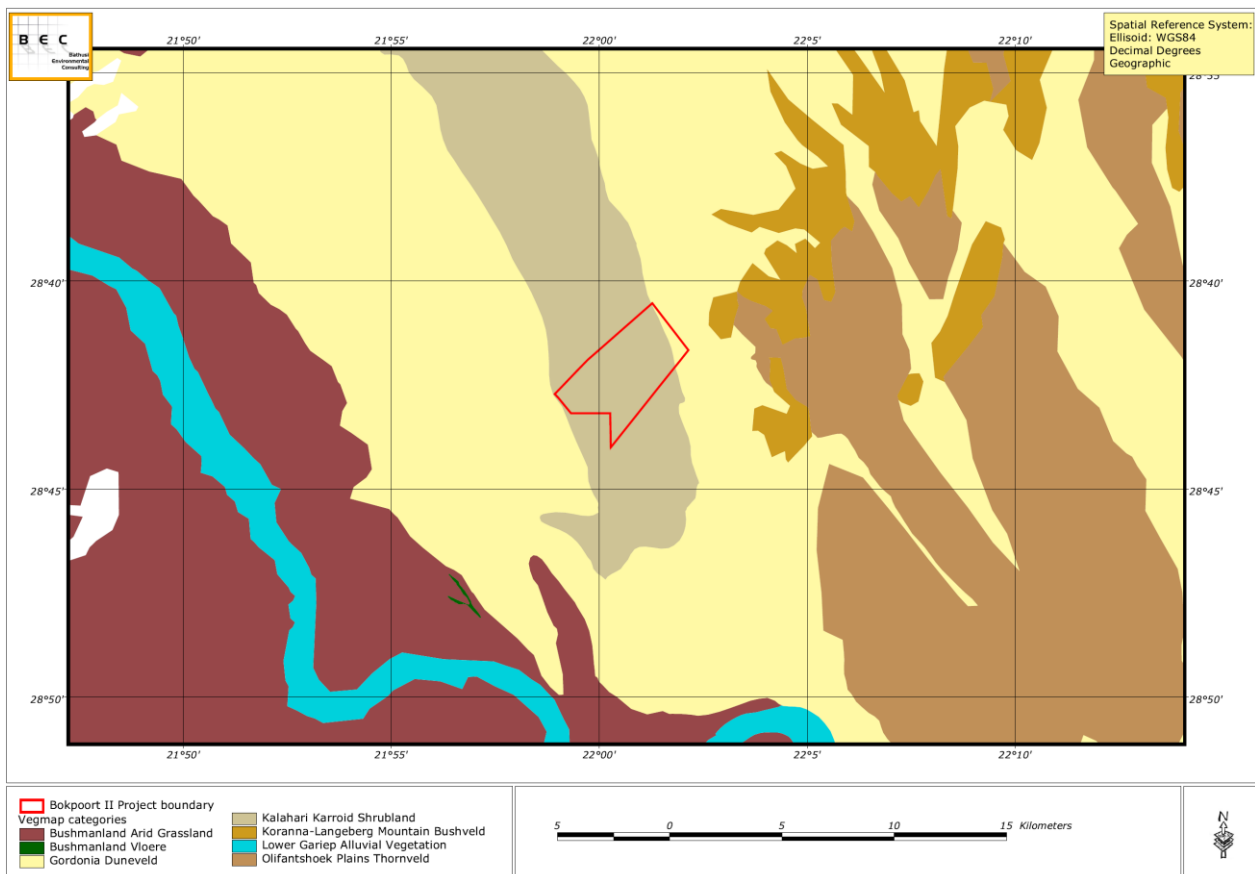

Figure 21: Regional ecological types in spatial relation to the study area

5.8.1 Alpha Diversity of the Study Area

A total of 112 plant species were identified during the site investigations (Appendix 1 of the Biodiversity Report – **Appendix C2**). The regional setting dictates the physiognomic dominance of the herbaceous component with 47 forb species (41.9 %) and 24 grass species (21.4 %). Trees and shrubs occur extensively throughout most of the study area (26 species 28.6 %) and apart from *Acacia erioloba* individuals are not particularly physically significant.

³¹ Mucina, L. and Rutherford, M.C. (eds.). 2006. *The vegetation of South Africa, Lesotho and Swaziland*. Strelitzia 19. South African National Biodiversity Institute, Pretoria.

Taking the setting of the study area into consideration, the species composition of untransformed vegetation types is regarded representative of the regional vegetation. A total of 35 plant families are represented in the study area, dominated by Poaceae (grass family, 24 species, 21.4 %), Fabaceae (16 species, 14.3 %) and Asteraceae (daisy family, 12 species, 10.7 %).

5.8.2 Declared Invasive Species and Common Weeds

Table 22 denotes a list of declared alien and invasive species and common weeds that were recorded on the study site during the 2010 site investigation.

Table 22: List of common weeds and declared alien and invasive plant species within the study area

Species Name	Status/ Uses	Common Name
<i>Acacia mellifera</i>	Declared indicator of encroachment, medicinal uses, poison source	Black Thorn
<i>Berkheya</i> species	Weed	--
<i>Flaveria bidentis</i>	Declared Invader - Category 1B (NEM:BA, 2004. AIP, 2016)	Smelter's bush
<i>Gomphocarpus fruticosus</i>	Medicinal uses, common weed	Milkweed
<i>Prosopis glandulosa</i>	Declared Invader - Category 1B in EC, FS, NE, WC. Category 3 in NC (NEM:BA, 2004. AIP, 2014)	Honey Mesquite
<i>Rhigozum trichotomum</i>	Declared indicator of encroachment	Three Thorn

5.8.3 Plants with Traditional Medicinal Uses

Table 23 denotes plant species with traditional medicinal and traditional uses that were recorded within the study site.

Table 23: List of traditional and medicinal uses within the study area

Species Name	Status/ Uses	Common Name
<i>Acacia erioloba</i>	Declining Status, Protected Tree (National Forest Act, 1998), edible parts, medicinal uses, firewood	Camel Thorn
<i>Acacia mellifera</i>	Declared indicator of encroachment, medicinal uses, poison source	Black Thorn
<i>Adenium oleifolium</i>	Poisonous parts	Sand Quick
<i>Aptosimum procumbens</i>	Medicinal uses (sheep)	
<i>Boscia albitrunca</i>	Protected Tree (National Forest Act, 1998), important fodder, traditional uses, traditional medicinal uses	Shepherd's Tree
<i>Cadaba aphylla</i>	Medicinal properties, potentially poisonous	Desert Spray
<i>Ceratotheca triloba</i>	Medicinal properties	Wild Foxglove
<i>Croton gratissimus</i>	Medicinal uses, larval food for <i>Charaxes candiope candiope</i>	Lavender fever-berry
<i>Dicoma capensis</i>	Medicinal uses	Koorsbossie
<i>Gomphocarpus fruticosus</i>	Medicinal uses, common weed	Milkweed

Species Name	Status/ Uses	Common Name
<i>Grewia flava</i>	Edible parts, weaving, traditional uses, declared indicator of encroachment	Velvet Raisin
<i>Kleinia longiflora</i>	Traditional uses	Sjambokbos
<i>Momordica balsamina</i>	Edible parts, medicinal uses	Balsam Pear
<i>Monechma genistifolium</i>	Medicinal uses	Medicinal uses, traditional uses
<i>Pergularia daemia</i>	Medicinal uses	Bobbejaankambro
<i>Plinthus sericeus</i>	None	--
<i>Senna italica</i>	Medicinal uses	Wild senna
<i>Solanum supinum</i>	Medicinal uses	
<i>Tribulus terrestris</i>	Medicinal uses	Common Dubbeltjie
<i>Tribulus zeyheri</i>	Medicinal uses, grazed but potentially poisonous	Devil-thorn Weed
<i>Ziziphus mucronata</i>	Edible parts, traditional medicinal uses, traditional uses	Buffalo-thorn

5.8.4 Broad-Scale Habitat Types

Despite a relative homogenous appearance and high correlation to the regional types, with the exception of extensive mountain ranges to the north, a relative obvious physiognomic variability is noted in the study area with plains alternating with parallel dunes in the northern parts. It is highly likely that various smaller phytosociological differences are present within each of the identified habitat types, but for the purpose of this assessment, the observed ecological units are considered similar in major phytosociological, physiognomic and biophysical attributes. Many plant species occur across all of the habitat types, but many of the differences between units are ascribed purely on the basis of terrain morphology, soil characteristics or changes in the dominance and structure of the plant species. Surface water and rainfall in this part of the Kalahari is scarce and, together with substrate, is a major driving force of vegetation development.

Results of the photo analysis and site investigations revealed the presence of the following habitat types within the development footprint (Figure 22):

- Calcareous Low Shrub Plains;
- Open Shrub Duneveld; and
- Open Shrub Plains.

The extent and coverage of habitat types within the study area is presented in Table 24.

Table 24: Extent of habitat types within the study area

Habitat Type	Extent (ha)
Calcareous Low Shrub Plains	494.8 ha
Open Shrub Duneveld	288.0 ha
Open Shrub Plains	664.6 ha

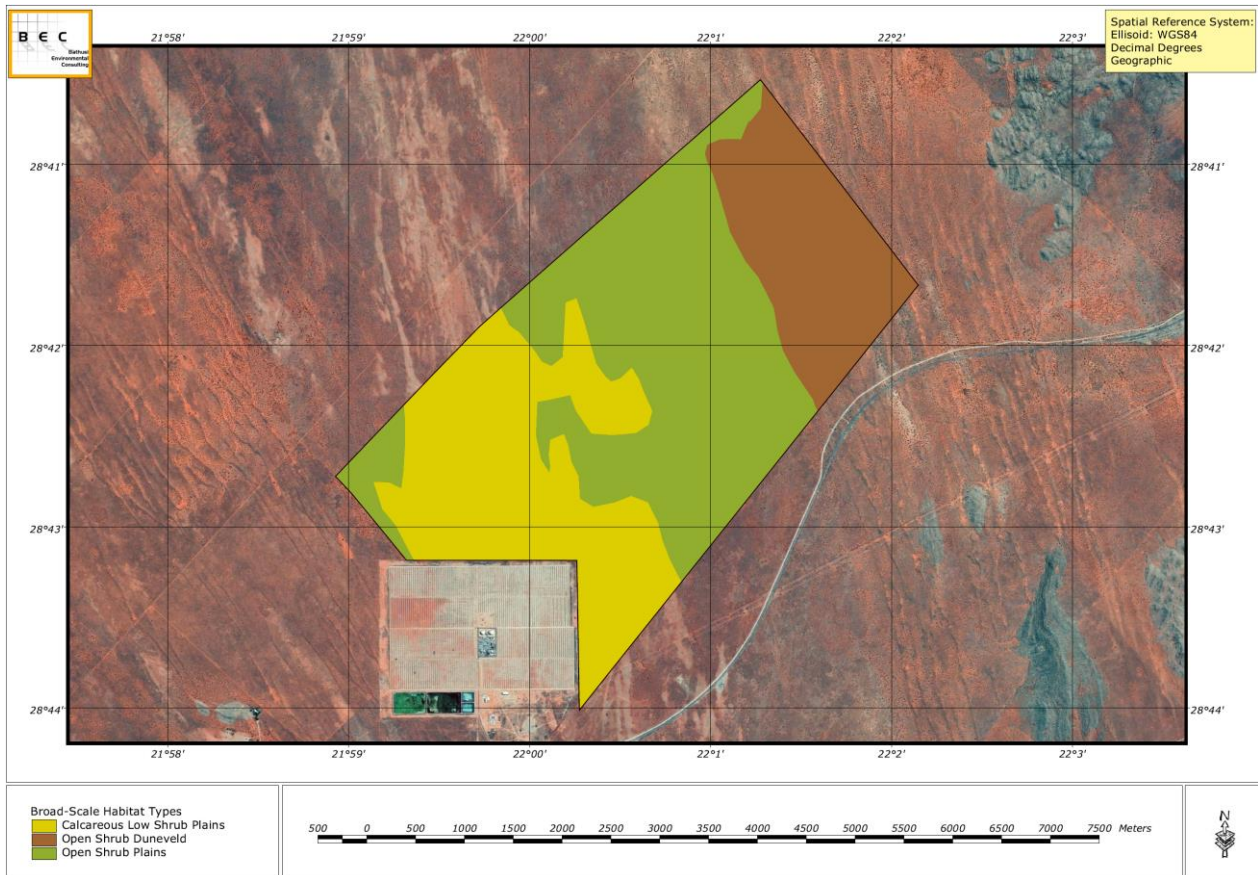

Figure 22: Broad-scale habitat types of the study area

5.8.5 Calcareous Low Shrub Plains

The topography of these areas are characterised by relative flat or slightly undulating plains where the substrate comprises whitish calcareous and compact sandy soils (grey to brown, not red) - Photograph 1. The vegetation is characterised by low shrubs and grasses; tall shrubs and trees are generally absent from this unit, or occur at extremely low intervals. Prominent species include the grasses *Enneapogon desvauxii*, *Eragrostis obtusa*, *Eragrostis truncata*, *Fingerhuthia africana*, *Stipagrostis ciliata*, the shrub *Salsola etoshensis* and the forbs *Pentzia calcarea*, *Eriocephalus spinescens*, *Monechma genistifolium* subsp. *australe*, *Geigeria* species. The shrubs *Rhigozum trichotomum* and *Lycium horridum* were observed in this unit.

The status of these areas appears to be relative degraded due to grazing pressure from sheep and other livestock; a moderate ecological integrity status is therefore ascribed.



Photograph 1: Example of calcareous low shrub plains

5.8.6 Open Shrub Duneveld

The major physiognomic attribute of this unit is the presence of low dunes with characteristic crests, slopes and streets with a floristic composition that largely conforms to an open tree savanna. Each of these units could be described as a variation of this unit on the basis of distinctive habitat attributes and species composition, but for the purpose of this investigation, they are considered holistically as they always occur in association with each other.

The physiognomy conforms to an open tree savanna (Photograph 2). Dominant species include the tree *Acacia mellifera* and the grass *Schmidtia kalahariensis*. Other prominent woody species are *Acacia haematoxylon*, *Parkinsonia africana*, *Rhigozum trichotomum*, *Boscia albitrunca* and *Acacia erioloba* and occasionally *Lycium bosciifolium*. Besides *Schmidtia kalahariensis*, the grass layer is characterised by *Eragrostis lehmanniana*, *Centropodia glauca*, *Stipagrostis amabilis*, *Brachiaria glomerata* *Stipagrostis obtusa* and *S. ciliata*. Herbs that are found in this unit include *Hermannia tomentosa*, *Hermbsstaedtia fleckii*, *Requienia sphaerosperma*, *Dicoma capensis*, *Momordica balsamina* and the climber *Pergularia daemia*.

The presence of the grass species *Schmidtia kalahariensis* is generally accepted as an indicator of high utilisation pressure. This habitat type is representative of the Gordonia Duneveld vegetation type and is in a relatively good condition. During subsequent visits, it appeared to be moderately degraded due to livestock grazing pressure. A moderate ecological integrity status and moderate-high sensitivity is therefore ascribed to this unit due to the association with dune habitat.



Photograph 2: Examples of open shrub duneveld habitat

5.8.7 Open Shrub Plains

This habitat type comprises the largest part of the study area. Biophysical attributes include open plains (flat or slightly undulating) with high shrubs and scattered trees on deep sandy, red soils or gravel plains and a well-developed herbaceous layer (Photograph 3).

The species diversity is relatively low; only 24 species were observed during the survey period. Prominent tall woody species in this undulating landscape are *Acacia erioloba*, *A. mellifera*, *Parkinsonia africana*, *Grewia flava* and *Boscia albitrunca*. Low shrubs include *Lebeckia linearifolia*, *Lycium bosciifolium*, *Rhigozum trichotomum* and *Salsola etoshensis*. Conspicuous grass species include *Schmidtia kalahariensis*, *Eragrostis lehmanniana* and *Stipagrostis ciliata*. Prominent forb species include *Monechma genistifolium* subsp. *genistifolium* and *Indigofera* species.

This habitat type is representative of the regional vegetation type Kalahari Karroid Shrubland which typically forms bands alternating with bands of Gordonia Duneveld. Due to similar grazing pressures in this vegetation community, a moderate floristic status is ascribed to this unit.



Photograph 3: Examples of open shrub plains

5.9 Faunal Attributes of the Study Area

5.9.1 Invertebrates

Invertebrate species previously recorded within the study area in 2010 were restricted to butterflies only (refer to Table 11 in the Biodiversity Assessment – **Appendix C2**). All species are common and ubiquitous species of the region, nevertheless the butterfly species richness is likely a factor of the largely untransformed and non-fragmented nature of the study area.

The invertebrates observed in the study area during the field investigation attested to a healthy, functioning ecosystem on the microhabitat as well as source-sink population dynamics scales. A total of 12 butterflies were observed in the study area; most of these species are common and widespread; if not in Southern Africa then in the drier western regions of the subcontinent. It is highly likely that many other species will complement the observed assemblage of butterflies should the study be repeated in early summer (the only flight time of some Lepidoptera groups, notably *Lycaenidae*). The drier western regions of South Africa have significantly fewer butterflies than the wetter east; consequently, the number of species observed during the field survey (given timing of the survey as well geographic location of the study area) confirms the untransformed and unfragmented nature of the study area.

Two invertebrate species of conservation concern (that have not yet been observed) could potentially occur within the study area, these and their likelihood of presence based on habitat suitability are summarised in Table 25 below.

Table 25: Butterfly species of conservation concern recorded in the region of the study area³²

Species	Common name	Conservation Status (IUCN)	Comment, PoO
<i>Alfredectes browni</i>	Brown's Shieldback	DD	Possible – This katydid species is understudied, being known only from three specimens, but occurs in a wide range of habitats from grasses along highly disturbed roadsides, to low trees, to high elevation fynbos vegetation so could occur within the study area
<i>Lepidochrysops penningtoni</i>	Pennington's Blue	DD	Unlikely – Considerable uncertainty exists around this species' taxonomy and distribution and it is likely that the species will fall into the category of Least Concern with further information as it occupies remote habitats and does not face any major threats. Its strongly seasonal appearance has probably led to it being under-recorded. It is thought to be endemic to the Northern Cape; however, it prefers vegetation consisting of <i>Mesembryanthemum</i> species and other low shrubs (succulent Karoo) which has not been recorded within the study area

5.9.2 Amphibians

No amphibian species have been recorded within the study area or in the immediate surrounds of the study site. Taking cognisance of the absence of surface water within the proposed development footprint, it is regarded unlikely that any of these species will occur on site; however, some frog species are expected to occur in the vicinity of the abstraction point in the Orange River.

³² Bathusi Environmental Consulting. 2010. Biodiversity Impact Assessment for the proposed Concentrated Solar Thermal Power Plant (Siyanda District, Northern Cape Province) on a portion of the Farm Bokpoort 390.

5.9.3 Reptiles

Seven reptile species were observed during the previous baseline fieldwork in 2010, confirmed species (Southern Rock Agama, Cape Cobra, Common Barking Gecko, Spotted Sand Lizard, Striped Skink, Serrated-tent Tortoise and Puff Adder) as well as other species whose distributions overlap with the study area and therefore could potentially occur.

5.9.4 Mammals

A total of fifty-one (51) mammal species are considered potentially occupants of the study area. Fourteen (14) of these have been confirmed during field studies. These and details of their conservation status/ level of protection afforded to them are listed in Table 15 of the Biodiversity Assessment – **Appendix C2**; species that have been confirmed present during fieldwork are provided in Table 26 below.

Table 26: Confirmed mammal taxa in the region

Scientific Name	Common Name	Conservation Status		
		IUCN - Regional status	NEMBA TOPS List	Northern Cape NCA
<i>Canis mesomelas</i>	Black-backed Jackal			
<i>Otocyon megalotis</i>	Bat-eared Fox		Protected	Specially Protected
<i>Caracal caracal</i>	Caracal			
<i>Atilax paludinosus</i>	Water Mongoose			Protected
<i>Cynictis penicillata</i>	Yellow Mongoose			Protected
<i>Galerella sanguinea</i>	Slender Mongoose			Protected
<i>Hystrix africaeaustralis</i>	Porcupine			
<i>Lepus capensis</i>	Cape Hare			Protected
<i>Lepus saxatilis</i>	Scrub Hare			Protected
<i>Ictonyx striatus</i>	Striped Polecat	Data Deficient		Specially Protected
<i>Mellivora capensis</i>	Honey Badger	Near Threatened		Specially Protected
<i>Orycteropus afer</i>	Aardvark		Protected	
<i>Pedetes capensis</i>	Springhare			

5.9.5 Bats

To date, there is little empirical data and very few peer reviewed experimental studies that have investigated the impacts of solar facilities on bats. Studies concerning landscape-scale impacts are also not available.

Under laboratory conditions, bats demonstrated drinking behaviour over smooth artificial plates as they confused these surfaces with water sources³³. This raised the concern of a risk of bats colliding with smooth PV panels as they may confuse it with water, possibly causing injuries and/ or fatalities. Greif *et al.*³⁴ investigated how bats interact with smooth vertical and horizontal surfaces. They confirmed the drinking behaviour over smooth horizontal surfaces and found bats mistake smooth vertical surfaces for open flight paths resulting in collision. The risk of injury or fatality by collision was thus with vertical surfaces rather than

³³ Greif, S. & Siemers, B. M. 2010. Innate recognition of water bodies in echolocating bats. *Nature Communications*, 2(1), 107.

³⁴ *Ibid.*

horizontal. Collision of bats with solar panels has not been investigated and is not confirmed. Given that PV arrays are typically tilted and not oriented vertically, risk of collision with PV panels cannot be inferred from these studies and is typically assumed to be low³⁵.

Additionally, a field experiment recorded bats leaving an area with artificial surfaces when they learnt after a few attempts that drinking from the surfaces was not possible³⁶. If there in fact is a risk of collision, over time bats should learn that PV panels are not water sources and search elsewhere for water. With enough time, collision risk should then be reduced to zero.

PV panels reflect horizontally polarized light and attract polarotactic insects (insects attracted to polarized light) as they perceive the panels to be water sources used for breeding purposes³⁷. It may be assumed that the attraction of insects to PV panels would in turn attract insectivorous bats to forage around the panels³⁸. However, there is no evidence to confirm the attraction of bats to the panels or collision by bats while foraging in the area of a PV facility.

PV panels are also more absorptive than reflective of sunlight, therefore, there is a risk of heat related injuries or fatalities associated with CSP technology that is less applicable to PV panels³⁹. The South African Bat Assessment Association website notes that bat fatalities have occurred at CSP facilities in South Africa (no further information of cause or location is provided) and mentions there to be no evidence that PV farms constructed on the ground in fields pose a direct fatality risk to bats.

5.10 Avifauna

5.10.1 Bird Microhabitats

The site visit in December 2019 confirmed that the main vegetation types and avifaunal micro-habitats that were originally identified in the initial avifaunal impact assessment report⁴⁰ remain largely unchanged. The micro-habitats include scattered kraals, reservoirs and associated water troughs for livestock farming, thornveld/scrubland, open grassy scrubland, gravel plains, and duneveld.

5.10.2 Avifaunal Community

The initial Bird Impact Assessment Report⁴¹ detailed the locations of three Verreux's Eagle and one Martial Eagle nests (Figure 23). These sites were revisited by the avifaunal specialist in December 2019 to confirm their status. The three Verreux's Eagle nests are close together and located approximately 4km to the east of the project site and represent a primary nest and two alternative nests from a pair of Verreux's Eagle. The pair of Verreux's Eagle were observed perched next to the identified nesting site and these nests can be considered to still be active.

³⁵ Taylor, R., Conway, J., Gabb, O., & Gillespie, J. (2019). *Potential impacts of ground-mounted photovoltaic solar panels*. BSG Ecology. Accessed from <https://www.bsg-ecology.com/potential-ecological-impacts-ground-mounted-photovoltaic-solar-panels-uk/>

³⁶ Russo, D., Cistrone, L., & Jones, G. (2012). *Sensory ecology of water detection by bats: a field experiment*. PLoS ONE, 7(10), e48144.

³⁷ Horvath, G., Blaho, M., Egri, A., Kriska, G., Seres, I., & Robertson, B. (2010). *Reducing the maladaptive attractiveness of solar panels to polarotactic insects*. *Conservation Biology*, 24(6), 1644-1653.

³⁸ Harrison, C., Lloyd, H., & Field, C. (2017). *Evidence review of the impact of solar farms on birds, bats and general ecology*. Natural England Technical Report. Available from: <http://publications.naturalengland.org.uk/publication/6384664523046912>

³⁹ Pimentel, D., Rodrigues, G., Wang, T., Abrams, R., Goldberg, K., Staeker, H., Ma, E., Boerke, S. (1994). *Renewable energy: economic and environmental issues*. *BioScience*, 44, 536-547.

⁴⁰ Pearson, A. 2016. *Avifaunal Impact Assessment Report: Bokpoort II Solar Farm*.

⁴¹ *Ibid*.

The Martial Eagle nest located approximately 1.55 km from the project site appeared to no longer be active during the December 2019 site visit. In 2015, the nest consisted of a stick structure placed on top of a sociable weaver nest in a transmission line tower with a lot of white-wash below. During the December 2019 site visit almost no stick structure remained, no new sticks had been added and significantly less white-wash was present below, therefore it appeared as if the nest had not been re-used for a few seasons. Martial Eagles exhibit strong fidelity to nesting sites⁴² but a breeding pair may alternate breeding attempts between multiple nests in their breeding territory⁴³, which range in size from 100 – 800km² in South Africa⁴⁴. Martial Eagle was not recorded in the project area over three months of monitoring by Jeal⁴⁵, nor has it been recorded in the project area or immediate surrounds by the SABAP2 project. The project area therefore may not constitute an important foraging area for these birds.

5.10.3 Avifaunal Sensitivity Zones

High Sensitivity Zones

High sensitivity zones were related to the identified eagle nest sites in the broader study area. These include a 3 km circular area around the Verreux's Eagle primary and alternative nest sites and a 1.5 km circular area around the previously used, but currently inactive Martial Eagle nest site. As some areas within these buffers are already altered and disturbed (e.g. by existing transmission lines, roads and a major railway line), other project infrastructure (e.g. PV panels, battery storage, pipelines and power lines) are allowed within the buffer areas if all the mitigations recommended are implemented.

Medium Sensitivity Zones

Medium Sensitivity Zones are areas identified on the project site that are currently important for avifauna, and/ or support important species and/ or support high abundances of birds at certain times. Two such types of zones were identified associated with gravel plains (which support important species such as coursers and bustards) and artificial water points. These areas are not sufficiently sensitive so as to preclude development and it is understood that should the project proceed these areas within the project site will be completely destroyed/ removed. This has been taken into account when conducting the impact assessment for habitat destruction and disturbance.

Undetermined Sensitivity Zones

Undetermined Sensitivity Zones are all the remaining areas of the project site not buffered in Figure 23 or related to the features discussed above. These areas show no obvious avifaunal features, patterns or sensitivities and are preferred for infrastructure placement. However, considering the general avifauna of the area and broader project area, it is likely that these zones are in fact of moderate sensitivity.

⁴² Herholdt, J.J., Mendelsohn J.M. 1995. Survival and nest-site fidelity in the Martial Eagle in the Kalahari Gemsbok National Park, South Africa. *J. Afr. Raptor Biol.* 10:33-34.

⁴³ Machange, R.W., A.R. Jenkins, and Navarro, R.A. 2005. Eagles as indicators of ecosystem health: is the distribution of Martial Eagle nests in the Karoo, South Africa, influenced by variations in land-use and rangeland quality? *Journal of Arid Environments* 63(1): 223 – 243.

⁴⁴ Hockey, P.A.R., Dean, W.R.J. and Ryan, P.G. (eds). 2005. *Roberts - Birds of southern Africa, VIIIth ed. The Trustees of the John Voelcker Bird Book Fund, Cape Town.*

⁴⁵ Jeal, C. 2017. *The impact of a 'trough' Concentrated Solar Power facility on birds and other animals in the Northern Cape, South Africa. Percy FitzPatrick Institute of African Ornithology, University of Cape Town. MSc. Thesis.*

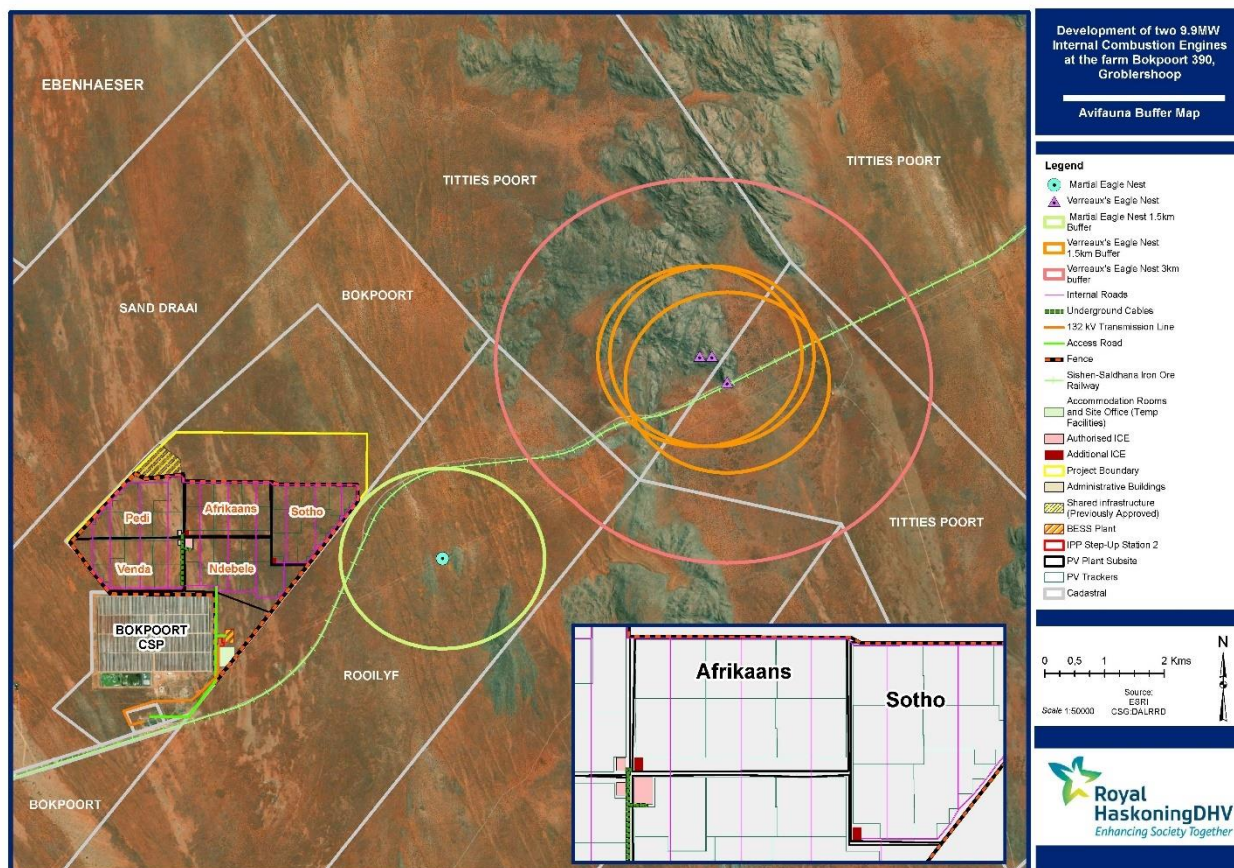

Figure 23: Locations of three Verreaux's Eagle and one Martial Eagle nests

5.11 Air Quality

5.11.1 Existing Sources of Emissions

▪ **Opencast Mining**

Iron ore and manganese mining occurs within the vicinity of the proposed project. Opencast mines are associated with significant dust emissions, sources of which include land clearing, blasting and drilling operations, materials handling, vehicle entrainment, crushing, screening, among others.

▪ **Construction of Solar Facilities**

Solar power facilities awaiting construction within a 60km radius of the project include two 100MW CSP facilities near Upington.

▪ **Other Fugitive Dust Sources**

Fugitive dust emissions may occur as a result of vehicle entrained dust from local paved and unpaved roads, wind erosion from open areas and dust generated by agricultural activities (e.g. tilling) and mining. The extent of particulate emissions from the main roads will depend on the number of vehicles using the roads, and on the silt loading on the roadways.

5.11.2 Air Quality Sensitive Receptors

In accordance with the Regulations Regarding Air Dispersion Modelling⁴⁶, two residences were identified as Air Quality Sensitive Receptors (AQSRs), located 4.8km to the southwest and 8.5km east of the site centre point. These were included in the dispersion model setup as discrete receptors. No schools or medical facilities are located within 10km of the proposed project. The closest residential areas are located outside of a 20km radius of the proposed project (Figure 24).

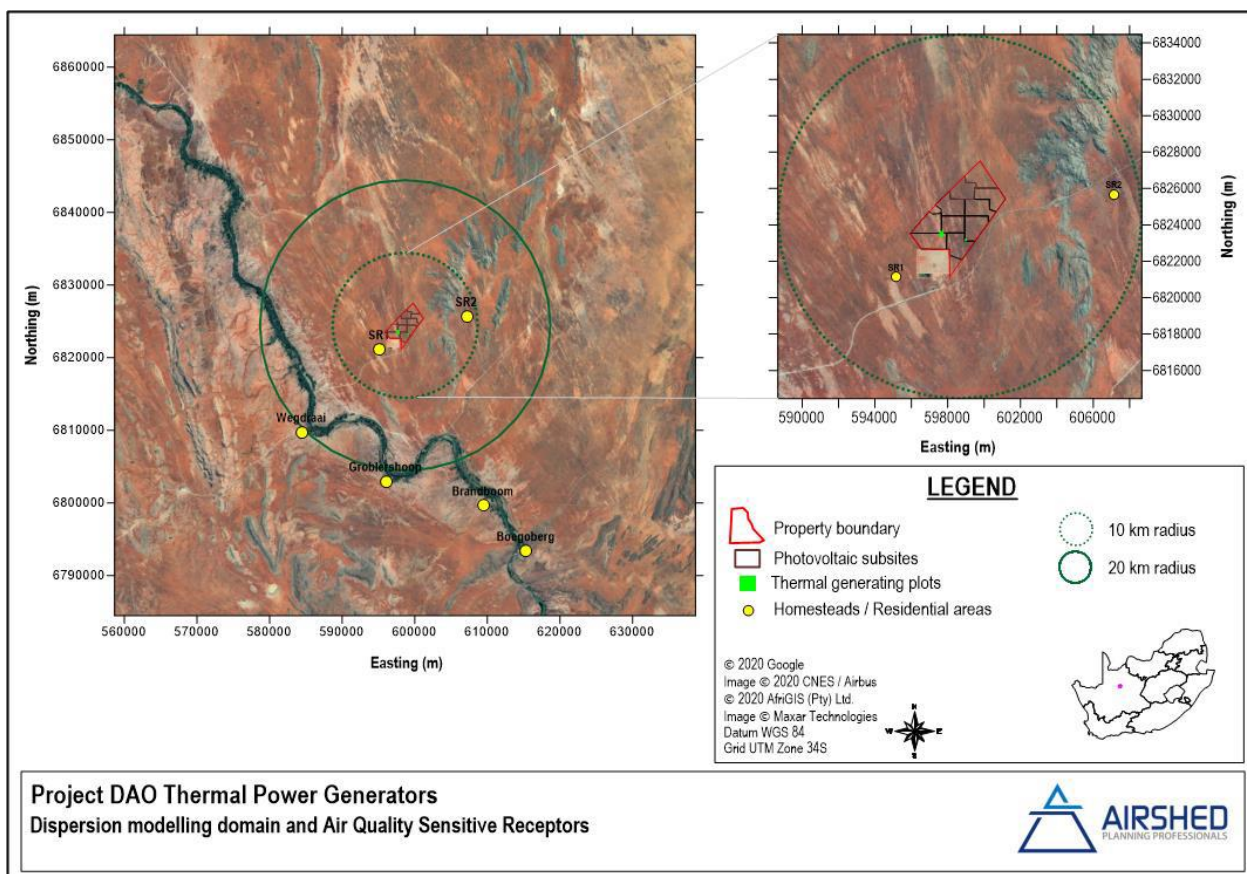

Figure 24: Location of the project in relation to the AQSRs

5.11.3 Baseline Ambient Air Quality

Measured air quality data from the DFFE Karoo Air Quality Monitoring Station (AQMS) was accessed from the South African Air Quality Information System (SAAQIS) for use in the assessment. The station is located near the town of Nieuwoudtville, 400km to the south-west of the proposed project area. The Karoo Station is considered by the DFFE to be a station measuring background levels of pollutants for the country since it is not influenced by typical sources resulting in high pollution loads (for example, industry, domestic fuel burning in high density residential areas, vehicle exhaust emissions in heavy traffic zones). Although the AQMS is located far from the project area, the sources in the vicinity and the climatic zones are similar. The period April 2018 to October 2020 was available from this online database. Data availability for the period varied between 6% and 97%, depending on the pollutant (Table 27). The following is noted from the dataset:

- No exceedances of the hourly National Ambient Air Quality Standards (NAAQS) were recorded for SO₂, NO₂, or CO during the period of assessment;

⁴⁶ Department of Environmental Affairs. 2014. Regulations regarding Air Dispersion Modelling. Department of Environmental Affairs, Government Gazette No. 37804, 11 July 2014.

- No exceedances of the daily NAAQS were recorded for SO₂, PM_{2.5}, or PM₁₀ during the period of assessment;
- Exceedances of the 8-hourly average O₃ NAAQ limit concentration occurred 22 times in 2018 and twice (so far) in 2020. The NAAQS allow for 11 exceedances of the 8-hourly O₃ limit concentration per year; and
- Compliance with annual NAAQS for all relevant pollutants in 2019 – the only year where data availability was sufficient to assess compliance.

Table 27: Summary of the ambient measurements at DFFE Karoo AQMS for the period 2018 – 2020

Karoo Background AQMS						
Period	Data Availability	Hourly 99 th Percentile	Daily 99 th Percentile	Annual Average	No of recorded hourly exceedances	No of recorded daily exceedances
SO₂ (ppb)						
<i>Criteria</i>		<i>134 ppb</i>	<i>48 ppb</i>	<i>19 ppb</i>	<i>88 hours per year</i>	<i>4 days per year</i>
2018(a)	47%	3.16	1.38	1.17	0	0
2019	95%	6.50	6.49	2.44	0	0
2020(b)	52%	5.20	4.76	1.59	0	0
NO₂ (ppb)						
<i>Criteria</i>		<i>106 ppb</i>		<i>21 ppb</i>	<i>88 hours per year</i>	
2018(a)	38%	7.84		1.17	0	
2019	82%	5.08		2.44	0	
2020(b)	48%	5.73		1.59	0	
CO (ppm)						
<i>Criteria</i>		<i>26 ppm</i>			<i>88 hours per year</i>	
2018(a)	41%	0.27			0	
2019	89%	0.50			0	
2020(b)	43%	2.00			0	
PM_{2.5} (µg/m³)						
<i>Criteria</i>		<i>n/a</i>	<i>40 µg/m³</i>	<i>25 µg/m³</i>	<i>n/a</i>	<i>4 days per year</i>
2018(a)	47%		11.54	1.17		0
2019	97%		16.29	2.44		0
2020(b)	30%		8.97	1.59		0
PM₁₀ (µg/m³)						
<i>Criteria</i>		<i>n/a</i>	<i>75 µg/m³</i>	<i>40 µg/m³</i>	<i>n/a</i>	<i>4 days per year</i>
2018(a)	47%		17.25	1.17		0
2019	97%		39.53	2.44		0
2020(b)	29%		30.10	1.59		0
O₃ (ppb)						
<i>Criteria</i>		<i>n/a</i>	<i>61 ppb</i>		<i>n/a</i>	
2018(a)	24%		97.06			22
2019	66%		50.03			0
2020(b)	6%		75.23			2
Notes:						
(a) Incomplete year (April to December)						
(b) Incomplete year (January to October)						

Diurnal and seasonal variation plots – generated using open-air^{47 48} - of ambient SO₂, NO₂, CO (Figure 25) along with PM_{2.5} and PM₁₀ (Figure 26) measured at the DFFE Karoo AQMS show the variation of ambient concentrations over daily, weekly and annual cycles (mean with 95% confidence interval). The data have been normalised by dividing by the respective mean values to allow comparison of the shape of diurnal trends for the variables on very different measurement scales⁴⁹.

The pattern shows morning and late evening peak NO₂ concentrations possibly associated with vehicle traffic and domestic fuel burning. CO concentrations show a similar early morning and late afternoon peak possibly associated with vehicle traffic. A slight mid-day peak is evident for SO₂ and is likely associated with the break-up of an elevated inversion layer, in addition to the development of daytime convective conditions causing the plumes from stacks at small industry sources to be brought down to ground level. Particulate fractions (Figure 26) show increased concentrations in the late afternoon, possibly associated with domestic fuel burning or wind field patterns where higher wind speeds could result in entrainment of particulate matter from exposed areas. The only pollutant with a discernible seasonal pattern is CO which increases in late winter and spring and is possibly associated with veld fires.

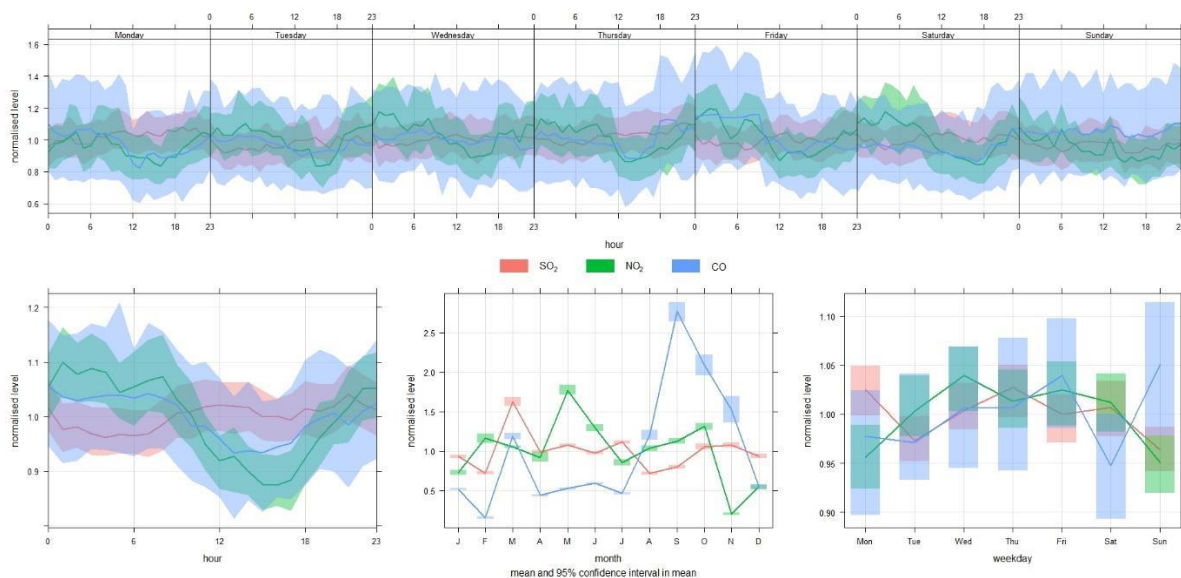

Figure 25: Diurnal and seasonal variation plots of observed SO₂, NO₂, and CO at the DFFE Karoo AQMS (shaded area indicates 95th percentile confidence interval)

⁴⁷ Carslaw, D., & Ropkins, K. 2012. *Openair - An R Package for Air Quality Data Analysis. Environmental Modelling and Software*, 27-28, 52 - 61.

⁴⁸ Carslaw, D. 2019. *The Openair Manual - Open-source Tools for Analysing Air Pollution Data. Manual for version 2.6-5. King's College London.*

⁴⁹ *Ibid.*

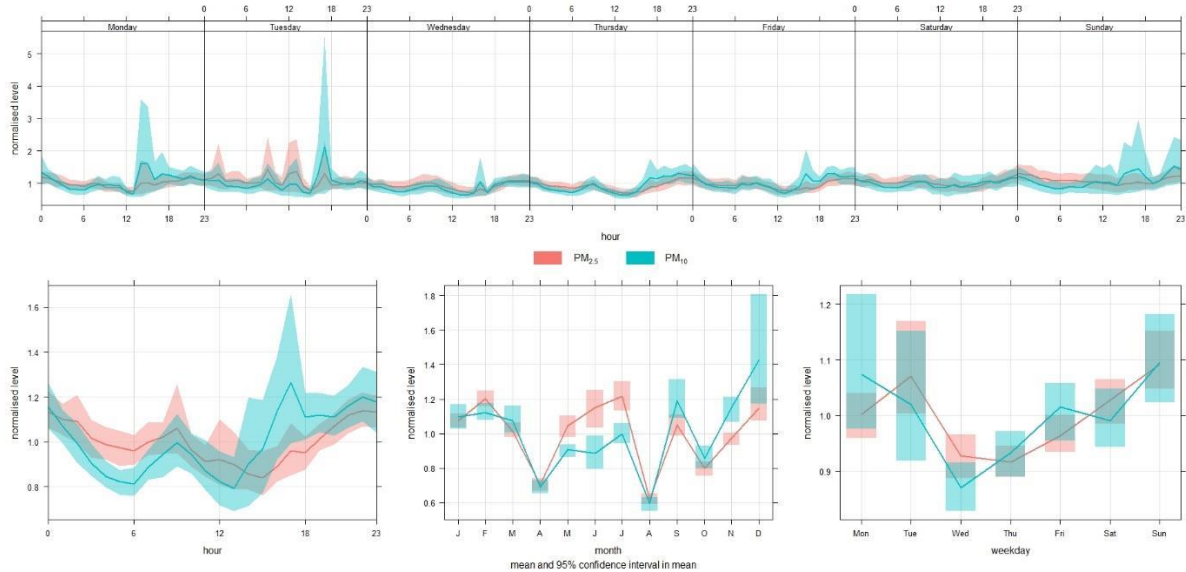

Figure 26: Diurnal and seasonal variation plots of observed PM_{2.5} and PM₁₀ at the DFFE Karoo AQMS (shaded area indicates 95th percentile confidence interval)

5.12 Heritage

5.12.1 Stone Age

Stone Age lithics dating to the Middle Stone Age are found only as low-density surface scatters, which is confirmed by similar findings in the larger region by other researchers^{50 51 52 53 54}. They are commonly found on the pebble plains where source material is readily available. The density of artefacts is less than 1/50 m². The tools are mostly made from banded iron stone (jaspelite), although some quartzite and hardened shale flakes were also noted. Cores, flakes and tools are found. The tools are very rough and informal and only a few that can be described as typical, i.e. blades and scrapers, were identified.

The low density of the lithic scatters is, on archaeological grounds, viewed to be of low significance and require no further action.

⁵⁰ Dreyer, C. 2014. First phase archaeological and heritage investigation of the proposed PV energy developments at the farm Sanddraai 391 near Groblershoop, Northern Cape Province. Bloemfontein: Unpublished report.

⁵¹ Dreyer, C. 2015. First phase archaeological and heritage impact assessment of the proposed Bokpoort II 300MW combined 2 x 75 PV and 150 MW CSP Tower Solar development on the remainder of the farm Bokpoort 390, Groblershoop, Northern Cape Province. Bloemfontein: Unpublished report.

⁵² Morris, D. 2014b. Proposed Kheis Solar Park Phases 1-3 on Portions 7 and 9 of the Farm Namakwari 656 and east of Grootdrink in Northern Cape: Heritage Impact Assessment. Kimberley: Unpublished report.

⁵³ Van der Walt, J. 2015. Archaeological impact assessment for the proposed Grootrink Solar PV facility east of Upington, Northern Cape Province. Unpublished report.

⁵⁴ Van Schalkwyk, J.A. 2019. Phase 1 Cultural Heritage Impact Assessment: prospecting right application with bulk sampling on various portions of the farms Zonderhuis 402, Onder Plaats 401 and Namakwari 656, Siyanda District Municipality, Northern Cape Province. Pretoria: Unpublished report 2019/JvS/102.



Photograph 4: Some identified tools and flakes

5.12.2 Iron Age

No sites, features or objects of cultural significance dating to the Iron Age were identified in the study area.

5.12.3 Historic period

Apart from current farming related features such as water troughs, no sites, features or objects of cultural significance dating to the historic period were identified in the study area.

5.13 Palaeontology

The Precambrian metamorphic and igneous basement rocks of the Namaqua-Natal Metamorphic Province in the study area are entirely unfossiliferous⁵⁵ and therefore not assessed further.

Late Caenozoic calcretes of the Kalahari Group may contain trace fossils such as rhizoliths, termite and other insect burrows, or even mammalian trackways. Mammalian bones, teeth and horn cores (also tortoise remains, and fish, amphibian or even crocodiles in wetter depositional settings) may be occasionally expected within Kalahari Group sediments and calcretes, notably those associated with ancient alluvial gravels and pans⁵⁶. However, these fossil assemblages are generally sparse, low in diversity, and occur over a wide geographic area, so the palaeontological sensitivity of the calcretes within the study region is rated as low. This applies equally to the thin veneer of other surface deposits (rocky scree, stream alluvium etc.) within this highly arid region.

Alluvial gravels of the Orange River of Miocene and younger age are locally highly fossiliferous^{57 58 59 60} and extensive references therein) but, these are not mapped within the study area. Younger silty alluvial deposits

⁵⁵ Almond, J.E. and Pether, J. 2008. *Palaeontological heritage of the Northern Cape. Interim SAHRA technical report, 124 pp. Natura Viva cc, Cape Town.*

⁵⁶ Almond, J.E. 2008. *Fossil record of the Loeriesfontein sheet area (1: 250 000 geological sheet 3018). Unpublished report for the Council for Geoscience, Pretoria, 32 pp. Natura Viva cc, Cape Town.*

⁵⁷ Hendey, Q.B. 1984. *Southern African late Tertiary vertebrates. In: Klein, R.G. (Ed.) Southern African prehistory and paleoenvironments, pp 81-106. Balkema, Rotterdam.*

⁵⁸ Schneider, G. & Marais, C. 2004. *Passage through time – the fossils of Namibia. 159 pp. Gamsberg MacMillan, Windhoek.*

⁵⁹ Almond, J.E. 2008. *Fossil record of the Loeriesfontein sheet area (1: 250 000 geological sheet 3018). Unpublished report for the Council for Geoscience, Pretoria, 32 pp. Natura Viva cc, Cape Town.*

⁶⁰ Almond, J.E. 2009. *Contributions to the palaeontology and stratigraphy of the Alexander Bay sheet area (1: 250 000 geological sheet 2816), 117 pp. Unpublished report for the Council for Geoscience. Natura Viva cc, Cape Town.*

may contain a range of terrestrial and freshwater fossils and subfossils. Freshwater snails are mentioned in particular by Moen⁶¹ (2007). Stream gravels close to the west bank of the Orange River in the Groblershoop area were examined without success for palaeontological remains by Almond (2012)⁶².

5.14 Traffic

5.14.1 Access to Site

Access to the proposed site is via a private Transnet Service Road (gravel), running adjacent to the Sishen-Saldanha railway line. The Transnet Service Road is accessed via the Gariep Road, currently a gravel road, from either the N8 or N14. The road also provides access to farms located further north. This road was upgraded (widened to 8m and gravelled) during the construction of Bokpoort I and meet the requirements for the proposed PV facilities. Permission for use of the road was obtained during the application for construction for Bokpoort I, however, permission will have to be obtained once again for the construction of the PV solar facilities.

5.14.2 Road Network and Intersections

The N14, N10 and N8 are the National roads in the region and are the main link between the economic centres of Gauteng and Namibia. Access to the site is via the Gariep Road the Transnet Service Road. Details of the road network are given in Table 28⁶³.

Table 28: Overview of road network

Road	Ownership	Geometry	Discussion	Layout
Gariep Road (MR874)	Northern Cape Department of Transport	Gravel road 2 lanes (one per direction) 10m wide Speed 60km/ hr Longitudinal profile: Flat	The road runs parallel and to the east of the Orange River serving as access to the farms along the Orange River. The road links the N14 with the N8. Major dust issues have been noted by farmers due to the increase of construction vehicles during the construction of Bokpoort I. The road is aligned through the southern sections of the farm Bokpoort. Condition: Fair	

⁶¹ Moen, H.F.G. 2007. *The geology of the Upington area. Explanation to 1: 250 000 geology Sheet 2820 Upington*, 160 pp. Council for Geoscience, Pretoria.

⁶² Almond, J.E. 2012. *Proposed upgrading of four road bridges along the N10 between Groblershoop & Lambrechtsdrift, Northern Cape. Recommended exemption from further palaeontological studies & mitigation*, 10 pp. Natura Viva cc, Cape Town.

⁶³ Van Wyk, L; Reutener, I. 2016. *Bokpoort II Solar Farm: Photovoltaic Facility 1 Site Traffic Assessment Groblershoop*.

Road	Ownership	Geometry	Discussion	Layout
Transnet Service Road (Loop 16 Access Road)	Transnet	Gravel road 2 lanes (one per direction) 10m wide Speed 60km/hr Longitudinal profile: Flat	Private Transnet Service Road to serve the Sishen-Saldanha Railway line. The road is the main access to the Bokpoort Farm Condition: Fair Road was regavelled during the construction of Bokpoort I	

The intersections are currently all unsignalized intersections and operating at a good Level of Service (LOS) with sufficient spare capacity⁶⁴.

Details of the LOS classifications are provided in Table 29.

Table 29: LOS classifications

LOS Category	Description
A	Free flow
B	Reasonably free flow
C	Stable flow, at or near free flow
D	Approaching unstable flow
E	Unstable flow, operating at capacity
F	Forced or breakdown flow

Details of the LOS expected at the Gariep Road and Transnet Service Road intersection are provided in Table 30.

Table 30: Overview of Gariep Road/ Transnet Service Road intersection

Intersection	LOS	Discussion	Layout
Gariep Road/Transnet Service Road	Existing A		
	During Construction (Phased Construction): A	Sight distance: Fair, after bridge over rail Dedicated right turning lanes: None	
	Southern approach: A	Safety: Poor Very little traffic currently on road	
	During Construction (Simultaneous Construction): A	The approach to the intersection is poor, with poor visibility and geometry	
	Southern approach: D		
	During Operation: A		

⁶⁴ Van Wyk, L; Reutener, I. 2016. Bokpoort II Solar Farm: Photovoltaic Facility 1 Site Traffic Assessment Groblershoop.

5.14.3 Non-Motorized Transport

No pedestrians or cyclists were noted on any of these roads (Gariiep Road, N14, N10, N8) during the site visit (19 November 2019). No cyclists or pedestrians are allowed on the National roads (N14, N10, N8). Workers and staff working on the farms along the Gariiep Road, mostly live on the farms. This is similarly the case with the Transnet Service Road. There are no towns or settlements along these two roads, apart from the farms along the Gariiep Road. No dedicated non-motorized transport facilities are provided or required.

5.14.4 Accident Hotspots

The Gariiep Road is an accident hotspot and has seen a number of fatal accidents due to speeding, overtaking and poor visibility caused by dust generated by the vehicles using the road.

5.14.5 Railway Lines

The Sishen-Saldanha railway line runs adjacent to the farm Bokpoort 390 RE. The railway line could potentially be used for transport of materials to site, but it is highly doubtful if a special train will be scheduled to this site due to lack of rolling stock from Transnet's side. Rail was not used during the construction of Bokpoort I, and therefore it is assumed that it is highly unlikely that the Sishen-Saldanha railway line will be used during the construction of the proposed PV plants.

5.14.6 Proposed Refuse Sites

The proposed refuse sites and haul distance include:

- Holfontein (hazardous waste) (814 km via N8); and
- Local Municipality (general waste) at Groblershoop (35 km).

5.14.7 Haul Routes

The shortest haul route from Gauteng is via the N8 as shown in Table 31 (Figure 27).

Table 31: Haul distance from Gauteng

Road Distances from Gauteng	Length (km)
Johannesburg CBD to Bokpoort via N8 and R59	794
Johannesburg CBD to Bokpoort via N8 and N12	795
Johannesburg CBD to Bokpoort via N14 via Upington and then N10	908
Johannesburg CBD to Bokpoort N14 (Gariiep Road) – not allowed	811

The Gariiep Road from the N14 is not recommended as a haul route due to the road safety and dust issues. This route is however 97 km shorter than the alternative via the N10 when travelling from Upington. This should be noted in the construction tender.

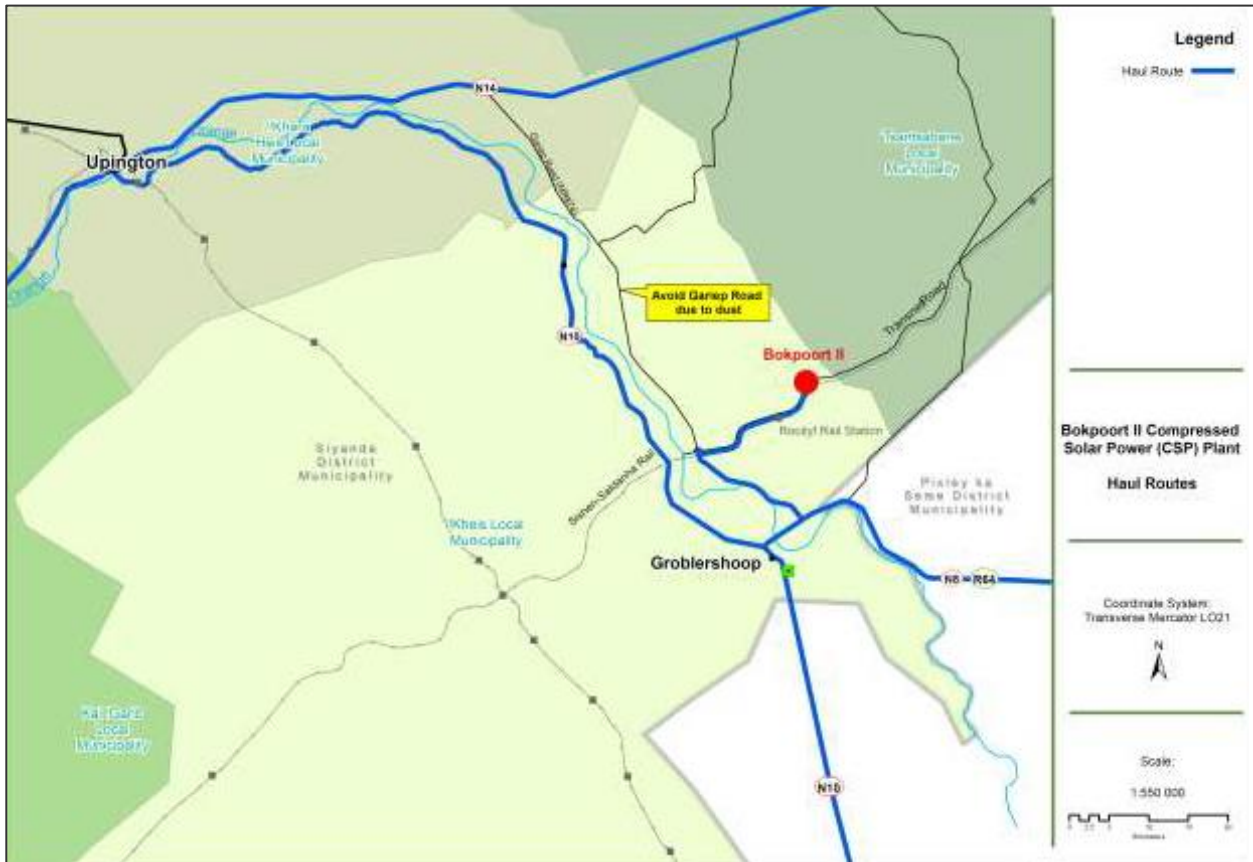

Figure 27: Haul routes

5.14.8 Traffic Counts

The major intersections were counted on 9 - 10 March 2016 as well as on 19 November 2019. The traffic volumes are summarized in Table 32 and Table 33 below.

Table 32: Traffic volumes 2016 (peak hour)

Intersection	Morning peak hour Volumes	Afternoon peak hour volumes	Daily volumes
N14/ Gariep	168	157	16800
Gariep/ Transnet	36	46	265
N8/ Gariep	257	274	1340

Table 33: Traffic volumes 2019 (peak hour)

Intersection	Morning peak hour Volumes
Gariep/ Transnet	13

5.14.9 Road Hierarchy

The road hierarchy is shown in Table 34 below. Traffic calming and parking is typically not allowed along the Mobility Corridors (Class 1, 2, 3), but is allowed along the Access Routes (Class 4, 5).

Table 34: Road hierarchy

Road	Class	Speed (km/ hr)
N14, N10, N8	Class 1, National Road	120
Gariep Road	Class 3, Minor arterial	80
Transnet Service Road	Class 5, Local access road	60

5.14.10 Public Transport Infrastructure

There are no dedicated public transport loading/ pick-up bays along the Gariep Road and the Transnet Service Road. There are no scheduled public transport routes along these two roads. Minibus-taxis transport construction staff to Bokpoort I from the adjacent residential areas. The developer will have to provide transport to site for the construction staff.

5.14.11 Dust

Due to the nature of the Gariep Road (calcrete) and the speed at which vehicles travel, a large amount of dust is generated by vehicles travelling on the road. The dust generated has an impact on the farming production rates. This is especially evident for farms where the Gariep Road is close to vineyards (within 1 km). Various complaints were received during the construction of Bokpoort I from farmers regarding dust generated by construction vehicles. The dust generation is a factor at the Gariep/ Transnet Service Road intersection as it affects the decision time for vehicles turning toward the proposed PV development.

5.15 Visual

5.15.1 Landscape Physical Characteristics and Land Use

The land use in the study area has changed little in the four year-period since the original visual reports were compiled. Away from the Orange River corridor the predominant land use in the wider study area and including the majority of the Bokpoort Farm remains livestock rearing, predominately sheep. The Orange River valley/ corridor is predominated by the presence of irrigated agriculture, with the establishment of grape (sultana) vineyards evidently becoming more common. Game farming and hunting still occur in the Kalahari Oryx Game Farm located to the north and north-west of the Bokpoort Farm. The Bokpoort (1) CSP plant remains the only energy generation-industrial facility in the wider area with no other solar or wind power generation facilities having been constructed to date. There appears to have been little to no growth in settlements in the study area, with Groblershoop remaining a small rural town along with a handful of smaller settlements located close to the Orange River corridor.

5.15.2 Visual Receptors

All sensitive receptor locations in the 10 km radial area are presented in Table 35.

Table 35: Static sensitive receptor locations located within a 10 km radius of the proposed development site

Distance (radius around infrastructure)	Receptor Type	Receptor Name	Closest Distance to Proposed Development	Receptor located Within Viewshed
0 - 5km	Farmstead (main homestead and smaller household)	Bokpoort Farmstead	1,97km	Yes
5 - 10km	Two Farmsteads	Eben Haeser Farmstead	7.71km	No
	Farmstead (main homestead and smaller household)	La Gratitude Farmstead	6.25km	No
	Farmstead (main homestead and 3 smaller households)	Tities Poort Farmstead	7.9km	No
	Farmstead (main homestead and 2 smaller households)	Dinas Rus Farmstead	9.34km	No
	Farmstead (2 households)	Bloubos Farmstead	10.38km	No
	Farmstead (3 households)	Hoekvalkte Farmstead	10.58km	No

Seven (7) structures are located within a 5km radius around the site, all of which were listed as households. However only two are non-industrial or non-power generation-related, being the Bokpoort Farmstead and an associated farmworker's dwelling. The remainder are located either at the Bokpoort CSP Plant or at the Eskom Garona Substation. As such these other structures and the people working within them are unlikely to display any degree of visual sensitivity and accordingly only one sensitive receptor location exists within a 5 km radius of the development footprint.

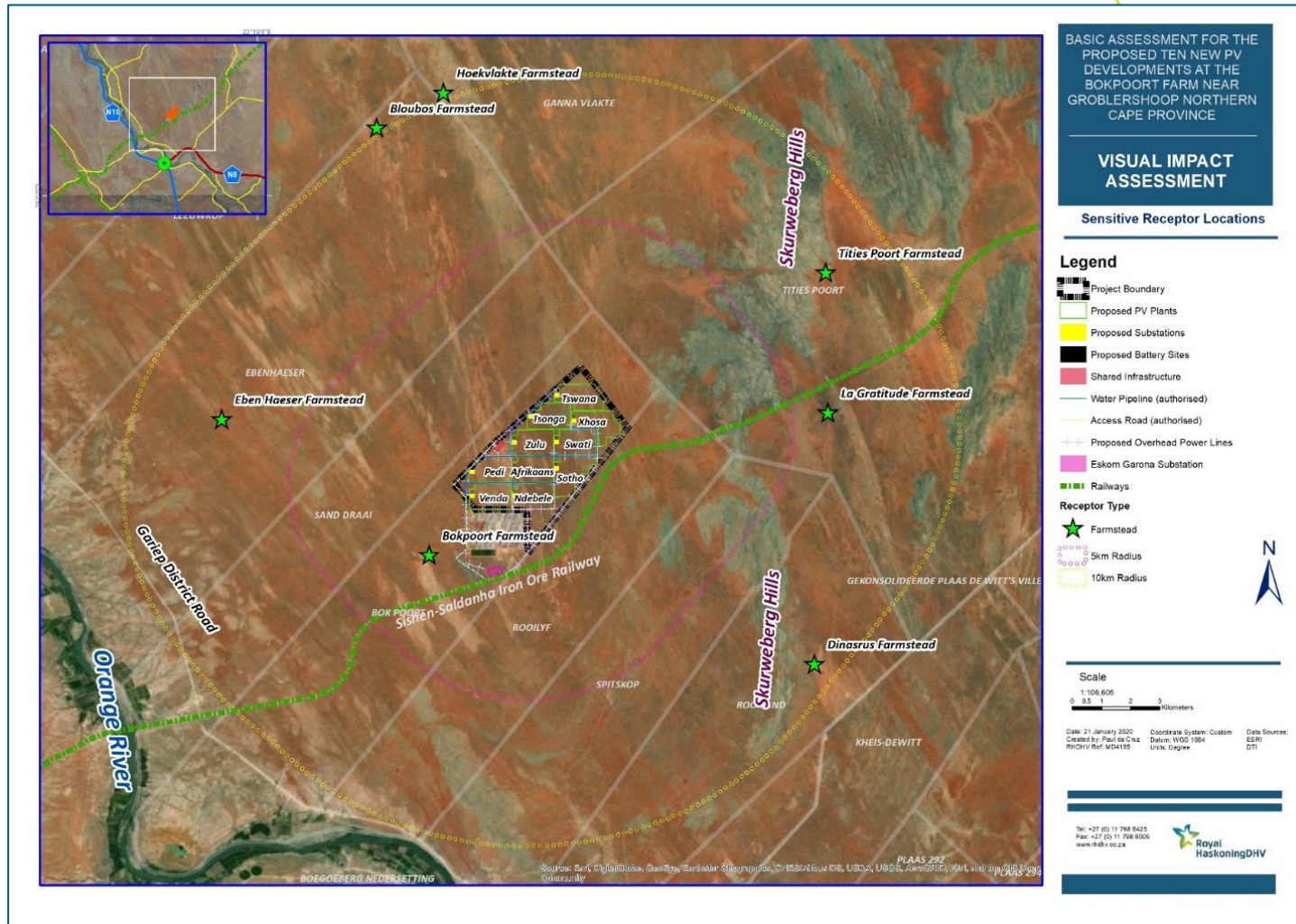

Figure 28: Location of sensitive receptor locations within a 10km radius of the proposed development

Within a 5 – 10 km radius, six (6) sensitive receptor locations were identified⁶⁵. All of these are farmsteads, with each farmstead typically consisting of a number of households.

There are no public access transient receptor locations (i.e. roads or rail) located within the 0 – 5km radial area of the development site. The Transnet Service Road is located within the radial area however this is a non-public access road and access is limited to employees of Transnet, and for the stretch of the road from the Gariep Road to the Bokpoort CSP Plant, to people working at the solar power plant. This road is thus not considered as a route on which potential sensitive receptors could travel. The Transnet Railway is not a passenger railway, only transporting iron ore (raw materials) from Sishen to Saldanha. As such the railway can also not be considered to be a transient receptor location.

Only a short stretch of the Gariep Road enters the 10km radial area. This is the primary and only public access road located on the eastern side of the Orange River corridor in the area and which is located within the area surrounding the proposed development. The road runs from the N8 east of Groblershoop north-westwards, running largely parallel to the course of the river, in the direction of the small settlement of Gariep and eventually linking to the N14 National Road and Olifantshoek to the north. The road also provides access to the only other road bridge across the Orange River between Groblershoop and Upington. As such the Gariep Road is an important public route that carries local traffic in the area to the north-east of Groblershoop.

5.16 Noise Baseline

Receptors were identified by means of desktop assessment (up to 2000m from the project footprint). Receptor positions are presented in Figure 29.

Only one receptor within immediate proximity (2000m) of the site footprint was identified. Ambient noise measurements were performed at Point A (proposed development site) and Point B (Bokpoort Farmstead). Ambient noise measurements were performed at Point A (proposed development site) and Point B (Bokpoort Farmstead) - Table 36.

⁶⁵ The Hoekvalkte and Bloubos Farmsteads are located just outside of the 10km radial area but have been included in this assessment.

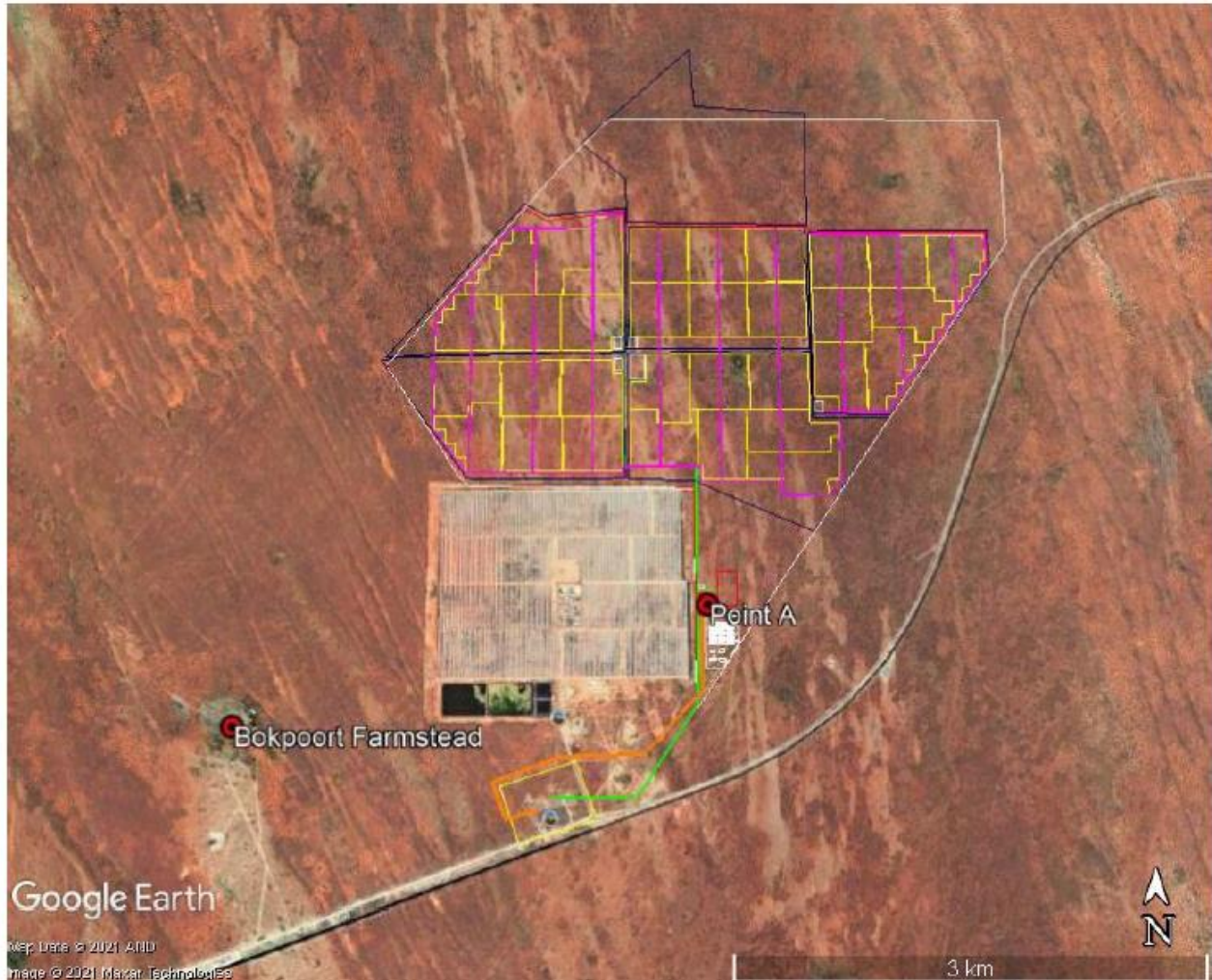

Figure 29: Noise sensitive establishments

Table 36: Rating levels

Measurement Point	Measurement Date	Recorded Ambient Noise Level during the Day (06:00 – 22:00) (L _{Aeq})	Recorded Ambient Noise Level during the Night (22:00 – 06:00) (L _{Aeq})	Comparative Rating Level (SANS10103:2008)
Point A	23/11/2020	45.2 dBA	42.6 dBA	Rural Districts (Daytime = 45 dBA and Night-time = 35 dBA)
	24/11/2020	41.5 dBA	39.0 dBA	
Point B	23/11/2020	45.4 dBA	42.9 dBA	Rural Districts (Daytime = 45 dBA and Night-time = 35 dBA)
	24/11/2020	45.0 dBA	39.3 dBA	

From the baseline noise survey, it was found that the comparative rating level (SANS 10103:2008) for both measurement points were to be considered a rural district. However, Point B is located in an industrial zone

which will allow for the noise levels to increase to an industrial district (70 dBA day-time – 60 dBA night-time).

5.17 Socio-economic Baseline

Socio-economic impact assessments were undertaken during November 2015 to February 2016 in support of the 75 MW Photovoltaic PV 1 and PV 2 as well the 150 MW CSP solar facilities by Smith and de Waal^{66 67 68} as well as for the Bokpoort CSP project conversion of the temporary accommodation to permanent accommodation.

5.17.1 Administrative Setting

The proposed project area is located in Ward 3 of the !Kheis Local Municipality (LM), ZF Mgcawu District Municipality (DM), Northern Cape Province. The ZF Mgcawu DM, which is classified as a category C Municipality forms the mid-northern section of the province on the frontier with Botswana. It covers an area of more than 100 000 square kilometres (almost 30% of the entire province). The DM comprises six local Municipalities namely: Mire; Kai! Garb; Kara Hails; Tsantsabane, !Kheis and Kgatelopele. Upington is the district municipal capital.

The !Kheis Local Municipality, formerly the Groblershoop Municipality, includes the settlements of Boegoeberg, Gariep, Grootdrink, Kleinbegin, Opwag, Topline and Wegdraai, was established from the. These settlements were previously part of the Siyanda and Karoo District Municipalities, who administrated these settlements and provided them with services up until the demarcation in November 2000. From December 2000, the !Kheis Municipality took over services and personnel and total service provision commenced on 1 July 2001⁶⁹.

The IFCs Performance Standard 7 provides criteria for the identification of indigenous people and requires that project proponents implement culturally appropriate measures to mitigate the impacts of a project on indigenous people.

The South African government has acknowledged the Khoi and San as the original indigenous people of South Africa. The presence of Khoisan people in the municipality triggered further investigation into the presence of an indigenous population in the Bokpoort II project area. The Socio-economic impact assessment confirmed that there is no evidence of the presence of any indigenous people residing or utilising the project area and immediate surrounds.

5.17.2 Population Demographics

According to available socio-economic baseline information, the total population of the !Kheis LM increased from 14950 in 1996 to 16539 in 2001 and 16637 in 2011. The Census of 2011 indicated 60.3% of the population to be of working age, 4.7% to be older than 65 and 35% to be younger than 16. The average population density in the Municipality is one person per square kilometre.

In 2011, Ward 3 of the !Kheis LM had a population of 2510 and the population of ZF Mgcawu DM was 157318. Groblershoop, 22km to the south, is the closest town to the proposed project area and it had a total population of 4938 in 2011.

⁶⁶ Smith, T; de Waal, D. 2016. *Socio-economic Impact Assessment for the proposed 75 MW Photovoltaic (PV1) Solar Facility (Bokpoort II Solar Development)*. Report No 1400951-302448-18.

⁶⁷ Smith, T; de Waal, D. 2016. *Socio-economic Impact Assessment for the proposed 75 MW Photovoltaic (PV2) Solar Facility (Bokpoort II Solar Development)*. Report No 1400951-303533-1.

⁶⁸ Smith, T; de Waal, D. 2016. *Socio-economic Impact Assessment for the proposed 150 MW CSP Tower Facility (Bokpoort II Solar Development) on the Remaining Extent of the Farm Bokpoort 390, Northern Cape*. Report No 1400951-299899-7.

⁶⁹ ZF Mgcawu District Municipality *Integrated Development Plan (IDP) 2016 - 2017*.

There were 4146 households in the LM of which 1209 were defined as agricultural households in the 2011 Census. The average household size was nearly four people per household and 33% of the households were headed by females.

Formal dwellings (66.3%) dominated the types of dwellings found in the municipality, but only 16.7% had piped water inside their dwellings, 64% used electricity for lighting and 27% had flush toilets connected to a reticulated sewerage system. The next most available sanitation system was flush toilets with a septic tank. A quarter (25%) of the population of the LM and 7% of Ward 3 did not have access to any sanitation system. The sanitation and sewerage systems in Ward 3 and the !Kheis LM are still inadequate.

There is a strong reliance on wood for cooking fuel, which is not sustainable and can lead to the overexploitation of especially camel thorn (*Acacia erioloba*) trees in the area.

There was an influx of people and heavy equipment during the construction of the Bokpoort I plant on the Remaining Extent of the Farm Bokpoort 390 to the south of the project area. Construction has been completed and the Bokpoort I plant is currently being commissioned.

5.17.3 Levels of Education

There is a school in Groblershoop and several farm schools in the regional area. Education levels are relatively low - 13.5% of the municipal population above the age of 20 has no formal schooling. Only 4.5% of the population over the age of 20 received a high school education and only 14% of this group achieved Matric qualifications. The dominant language spoken in the Municipality is Afrikaans (93%).

5.17.4 Economic Activities

The regional Gross Value Added (GVA) for 2010 is depicted in Table 37. The GVA consists of mainly mining and quarrying (18%), Agriculture, forestry and fishing (15%) in ZF Mgcauw DM and Agriculture, forestry and fishing (33%) and Wholesale and retail trade, catering and accommodation (19%) in the !Kheis LM.

Table 37: Contribution to GVA (2010)⁷⁰

Industry	Northern Cape	ZF Mgcauw DM	!Kheis LM
Agriculture, forestry and fishing	7%	15%	33%
Mining and quarrying	24%	18%	0%
Manufacturing	4%	6%	5%
Electricity, gas and water	2%	3%	3%
Construction	2%	2%	1%
Wholesale and retail trade, catering and accommodation	11%	13%	19%
Transport, storage and communication	10%	12%	7%
Finance, insurance, real estate and business services	15%	11%	12%
Community, social and personal services	10%	8%	10%

⁷⁰ Source: Quantec Data (2010) as contained in Smith, T; de Waal, D. 2016. Socio-economic Impact Assessment for the proposed 75 MW Photovoltaic (PV1) Solar Facility (Bokpoort II Solar Development).

Industry	Northern Cape	ZF Mgcawu DM	!Kheis LM
General government	15%	12%	11%

The major established economic growth centres are located in the Kimberley and Upington sub-regions. These are likely to remain the main economic driving forces for the future and will continue to attract rural and urban migrants. The agriculture sector is the main economic sector in the region. The majority of households within the Municipality are involved in poultry production followed by livestock production (Figure 30).

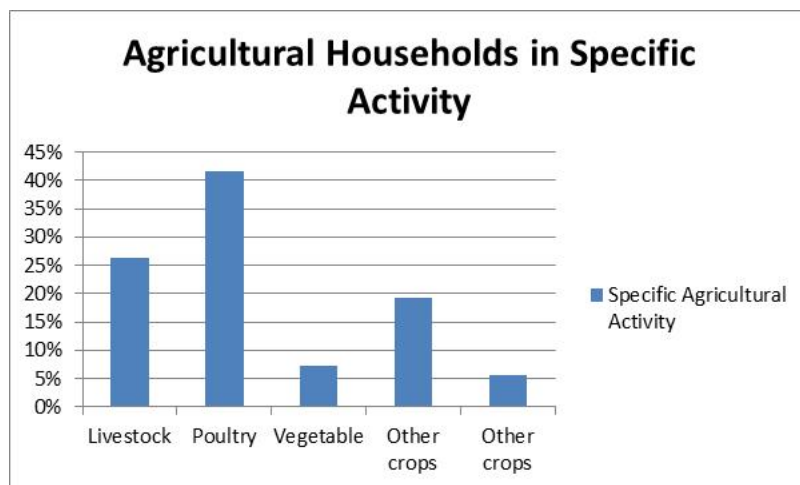

Figure 30: Percentage of agricultural households in each particular activity within the !Kheis LM⁷¹

The Orange River plays a crucial economic role in the ZF Mgcawu DM, with most of the economic activities linked to or located along the river. The Orange River area delivers a major part of South Africa’s table grape production. The Orange River Producers Alliance is a table grape industry that is renowned in as supplier of fresh table grapes to Europe with an output of more than 20 million cartons⁷².

More than 90% of Africa's total dried vine fruit production is produced through 1250 sultana grape growers in the Northern Cape who produced more than 50 000 tons in 2010. The sultanas produced here comprise more than 80% of that which is exported primarily to Europe and other eastern countries⁷³. SAD Vine Fruit Pty (Ltd) is located in Upington and owns the largest dried vine fruit processing and packaging plant in South Africa, employing more than 350 persons. It has intakes at Groblershoop, Mylpaal, Louisvalebweg, Keimoes, Kakamas and Vredendal⁷⁴.

The Orange River Wine Cellars Co-Op, also based in Upington, is the second largest winemaking cooperative in the world and has wine cellars at Groblershoop, Grootdrink, Upington, Keimoes and Kakamas. This Co-Op has more than 740 members who produce wine grapes and 445 farmers who produce grape juice⁷⁵.

In the ZF Mgcawu DM, there are approximately 1600 farmland units, which belong to 890 owners. Because of the difference in the carrying capacity of the field, there are relatively large differences in the sizes of the

⁷¹ Statistics South Africa. 2011. National Census.

⁷² !Kheis LM Integrated Development Plan (IDP) 2014 - 2015.

⁷³ ZF Mgcawu District Municipality Integrated Development Plan (IDP) 2016 - 2017.

⁷⁴ Ibid.

⁷⁵ Ibid.

farms. The carrying capacity of the field in this area can differ considerably between (for instance) a 10ha stock unit and 65ha stock unit further westwards⁷⁶.

The central parts of the region consist mainly of semi-desert areas and are, therefore, with a few exceptions, mainly suitable for extensive livestock farming. Livestock farming occurs mainly on large farms where farming is extensive. The larger majority of these farms are privately owned.

The renewable energy sector is also recognised as a key developing sector. There has been an increase in these types of projects in South Africa. There is currently an application to construct a Hydropower project at the Boegoeberg Dam in the Orange River. This project also falls within the local Municipality and would contribute to the local economy.

5.17.5 Employment Levels

The local Municipality unemployment rate is high at 28% in the 2011 Census indicating that there are limited formal job opportunities in the municipality. Youth, or persons 35 years or younger, comprise 34.3% of the municipal unemployment rate.

⁷⁶ ZF Mgawu District Municipality Integrated Development Plan (IDP) 2016 - 2017.

6 PUBLIC PARTICIPATION PROCESS

Public participation is a process that is designed to enable all interested and affected parties (I&APs) to voice their opinion and/ or concerns which enables the practitioner to evaluate all aspects of the proposed development, with the objective of improving the project by maximising its benefits while minimising its adverse effects.

I&APs include all interested stakeholders, technical specialists, and the various relevant organs of state who work together to produce better decisions.

The primary aims of the public participation (PP) process are:

- to inform I&APs and key stakeholders of the proposed application and environmental studies;
- to initiate meaningful and timeous participation of I&APs;
- to identify issues and concerns of key stakeholders and I&APs with regards to the application for the development (i.e. focus on important issues);
- to promote transparency and an understanding of the project and its potential environmental (social and biophysical) impacts (both positive and negative);
- to provide information used for decision-making;
- to provide a structure for liaison and communication with I&APs and key stakeholders;
- to ensure inclusivity (the needs, interests and values of I&APs must be considered in the decision-making process);
- to focus on issues relevant to the project, and issues considered important by I&APs and key stakeholders; and
- to provide responses to I&AP queries.

The PP process must adhere to the requirements of Regulations 39 - 44 (GNR 326 as amended). Further, a Public Participation guideline in terms of NEMA was issued by the DFFE in 2017, of which provisions have been implemented.

The PP process for proposed project has been undertaken according to the steps outlined in Figure 31 as well as the approved PP plan.



Figure 31: Steps in the public participation process

In order to achieve a higher level of engagement, a number of key activities have taken place and will continue to take place. These included the following:

- The identification of stakeholders is a key deliverable at the outset, and it is noted that there are different categories of stakeholders that must be engaged, from the different levels and categories of government, to relevant structures in the non-governmental organisation (NGO) sector, to the communities of wards of residential dwellings which surround the study area;
- The development of a living and dynamic database that captures details of stakeholders from all sectors;
- The fielding of queries from I&APs and others, and providing appropriate information;
- The convening of specific stakeholder groupings/ forums as the need arises;
- The preparation of reports based on information gathered throughout the BA study via the PP process and feeding that into the relevant decision-makers;
- The PP process included distribution of pamphlets or Background Information Documents (BIDs); and
- Where appropriate site visits may be organised, as well as targeted coverage by the media.

The proposed project PP process has entailed the following activities.

6.1 Authority Consultation

The Competent Authority, the DFFE, is required to provide an Environmental Authorisation (whether positive or negative) for the project. The DFFE was consulted from the outset of this study and has been engaged throughout the project process. The Northern Cape Department of Environment and Nature Conservation (NCDENC) will be the commenting authority.

6.2 Consultation with Other Relevant Stakeholders

Consultation with other relevant key stakeholders has been undertaken through written correspondence in order to actively engage these stakeholders from the outset and to provide background information about the project during the BA process.

6.3 Site Notification

The EIA Regulations 2014 (as amended) require that a site notice be fixed at a place conspicuous to the public at the boundary or on the fence of the site where the activity to which the application relates and at points of access or high through traffic. The purpose of this is to draw people's attention to the project and make them aware that they are able to play a role in the project.

I&APs were identified primarily from responses received from the notices that were placed, notifying the public of the project and the invitation for the public to register as stakeholders and inform them of the PP process.

A number of notices at various noticeable locations (Boegoeberg Service Centre, Sterhnam Service Centre, Wegdraai Service Centre and Groblershoop Central Business District) in the study area (**Appendix F**).

6.4 Identification of Interested and Affected Parties

I&APs were identified through the previous EIA studies and has been updated on an on-going basis. E-mails were sent to key stakeholders and registered I&APs on 05 November 2021, informing them of the application for the project and indicating how they could become involved in the project.

The contact details of all identified I&APs are updated on the project database, which is included in **Appendix F**.

6.5 Background Notification

A background notification document for the proposed project was compiled in English and distributed to key stakeholders and registered I&APs via email.

The aim of this document is to provide a brief outline of the application and the nature of the development. It is also aimed at providing preliminary details regarding the BA study, and explains how I&APs could become involved in the project.

6.6 Advertising

In compliance with the EIA Regulations 2014 (as amended), notification of the commencement of the BA study and review of the draft cBAR for the project was advertised in the *Gemsbok* Newspaper on 08 December 2021 (**Appendix F**).

The primary aim of this advertisement was to ensure that the widest group of I&APs possible was informed and invited to provide input and questions and comments on the project.

The advert for the review of the revised cBAR will appear in the *Gemsbok* Newspaper from 27-29 April 2022.

6.7 Issues Trail

Issues and concerns raised in the PP process will be compiled into an Issues Trail (**Appendix F**).

6.7.1 Public Review of the Revised Consultation BAR

The revised cBAR will be made available for authority and public review for a total of 30 days (03 May – 01 June 2022).

The report has been made available at the following public locations within the study area, which are all readily accessible to I&APs:

- !Kheis Municipal Public Library – Groblershoop.
- Electronically on the Royal HaskoningDHV Website: <https://www.royalhaskoningdhv.com/en/south-africa/projects/environmental-reports>

6.8 Final BAR

The final stage in the BA study entails the capturing of responses and comments from I&APs on the revised cBAR in order to refine the BAR, and ensure that all issues of significance are addressed. An electronic copy of the final BAR will be sent to all registered I&APs.

7 IMPACT ASSESSMENT

7.1 Introduction

Impact assessments must take account of the nature, scale and duration of effects on the environment, whether such effects are positive (beneficial) or negative (detrimental). Each issue/ impact is also assessed according to the project stages from planning, through construction and operation to the decommissioning phase. Where necessary, the proposal for mitigation or optimisation of an impact is noted. A brief discussion of the impact and the rationale behind the assessment of its significance is provided in this Section.

The EIA of the project activities is determined by identifying the environmental aspects and then undertaking an environmental risk assessment to determine the significant environmental aspects. The environmental impact assessment is focussed on the following phases of the project namely:

- Pre-Construction Phase;
- Construction Phase; and
- Operational Phase.

Decommissioning is not foreseen in the next 30 years.

The previous draft cBAR considered Liquefied Petroleum Gas (LPG) or Liquefied Natural Gas (LNG) in the generators, however, this option is no longer feasible. The impact assessment has therefore focussed on diesel as a fuel source in the generators which is now preferred.

7.2 Impact Assessment Methodology

The potential environmental impacts associated with the project will be evaluated according to its nature, extent, duration, intensity, probability and significance of the impacts, whereby:

- **Nature:** A brief written statement of the environmental aspect being impacted upon by a particular action or activity;
- **Extent:** The area over which the impact will be expressed. Typically, the severity and significance of an impact have different scales. This is often useful during the detailed assessment phase of a project in terms of further defining the determined significance or intensity of an impact. For example, high at a local scale, but low at a regional scale;
- **Duration:** Indicates what the lifetime of the impact will be;
- **Intensity:** Describes whether an impact is destructive or benign;
- **Probability:** Describes the likelihood of an impact actually occurring; and
- **Cumulative:** In relation to an activity, means the impact of an activity that in itself may not be significant but may become significant when added to the existing and potential impacts eventuating from similar or diverse activities or undertakings in the area.

The identified impacts are assessed in accordance with the approach outlined below extracted from the Final EIR compiled by Golder Associates⁷⁷ (terminology from the Department of Environmental Affairs and Tourism Guideline document on EIA Regulations, April 1998). This approach incorporates two aspects for assessing the potential significance of impacts, namely occurrence and severity, which are further subdivided as follows:

⁷⁷ Schlechter, M., & Baxter, B. 2016. *Final EIA Report: Proposed 75MW Photovoltaic (PV2) Solar Development on the Remaining Extent of the Farm Bokpoort 390, Northern Cape*. Golder Associates. Ref 14/12/16/3/3/2/880.

Occurrence		Severity	
Probability of occurrence	Duration of occurrence	Scale/extent of impact	Magnitude (severity) of impact

To assess each of these factors for each impact, the following four ranking scales are used:

Table 38: Criteria for the ranking of impacts

Probability	Duration
5 - Definite/ don't know	5 - Permanent
4 - Highly probable	4 - Long-term
3 - Medium probability	3 - Medium-term (8 - 15 years)
2 - Low probability	2 - Short-term (0 - 7 years) (impact ceases after the operational life of the activity)
1 - Improbable	1 - Immediate
0 - None	0 - None
Scale	Magnitude
5 - International	10 - Very high/ don't know
4 - National	8 - High
3 - Regional	6 - Moderate
2 - Local	4 - Low
1 - Site only	2 - Minor
0 - None	0 - None

Once these factors have been ranked for each impact, the significance of the two aspects, occurrence and severity, must be assessed using the following formula:

$$\text{SP (significance points)} = (\text{magnitude} + \text{duration} + \text{scale}) \times \text{probability}$$

The maximum value is 100 significance points (SP). The impact significance is then rated as follows:

Table 39: Impact significance

SP >75	Indicates high environmental significance	An impact which could influence the decision about whether or not to proceed with the project regardless of any possible mitigation.
SP 30 - 75	Indicates moderate Environmental significance	An impact or benefit which is sufficiently important to require management and which could have an influence on the decision unless it is mitigated.
SP <30	Indicates low environmental significance	Impacts with little real effect and which should not have an influence on or require modification of the project design.
+	Positive impact	An impact that constitutes an improvement over pre-project conditions

The suitability and feasibility of all proposed mitigation measures will be included in the assessment of significant impacts. This will be achieved through the comparison of the significance of the impact before and after the proposed mitigation measure is implemented. Mitigation measures identified as necessary will have been included in the EMPr (**Appendix E**).

7.3 Potential Impacts and Significance

The following sections will provide a description of the potential impacts as identified in the previous EIA studies for the site⁷⁸, by the specialist assessment, EAP and through the PPP as well as the assessment according to the criteria described in Table 38 and Table 39.

The environmental impacts of the project were assessed for the:

- Construction phase;
- Operational phase; and
- Closure and rehabilitation phase.

Potential cumulative impacts were also identified and assessed for each component, where applicable.

7.3.1 Geotechnical

7.3.1.1 Construction

The fuel storage tanks associated with the ICE, would typically induce foundation pressures of 100 -120 kPa beneath the envisaged ring-beam, when wind loads are considered⁷⁹. The ICE exhaust stack could be up to 70 m in height with varying distances of horizontal runs that would require support. Typical Design Loads to accommodate the horizontal supports would induce approximately 50 kPa of foundation pressure and could be mitigated using conventional pad foundations. Piled foundations could be required for lattice stack structures⁸⁰.

The impact is of a **moderate (SP = 36)** significance without mitigation and **low (SP = 28)** with mitigation.

7.3.2 Soils and Agricultural Potential

7.3.3.1 Construction

During construction, agricultural grazing land directly occupied by the development infrastructure, which includes all associated infrastructure, will become unavailable for agricultural use. The impact is assessed as being **moderate** with and without mitigation (**SP = 35**). The significance rating only comes out moderate because of the way the definite probability and the long-term duration influence the calculation. In the opinion of the Agricultural Specialist, the actual significance of this impact is low, and it has little real effect and does not need to have an influence on or require modification of the project design.

Soil degradation can result from erosion, topsoil loss and contamination. Erosion can occur as a result of the alteration of the land surface run-off characteristics, which can be caused by construction-related land surface disturbance, vegetation removal, and the establishment of hard surface areas including roads. Loss of topsoil can result from poor topsoil management during construction related excavations. Hydrocarbon spillages from construction activities can contaminate soil. Soil degradation will reduce the ability of the soil to support vegetation growth. The impact is **low** with mitigation (**SP = 18**) and the significance can be reduced even **lower (SP = 12)** with the implementation of the following mitigation measures:

- Implement an effective system of stormwater run-off control, where it is required - that is at all points of disturbance where water accumulation might occur. The system must effectively collect and safely disseminate any run-off water from all hardened surfaces and it must prevent any potential down slope

⁷⁸ Schlechter, M., & Baxter, B. 2016. *Final EIA Report: Proposed 150MW CSP Tower Development on the Remaining Extent of the Farm Bokpoort 390, Northern Cape*. Golder Associates. Ref 14/12/16/3/3/2/879.

⁷⁹ LibraTech Consulting. 2020. *Suitability for Construction Report – Bokpoort II PV Project*.

⁸⁰ *Ibid.*

erosion. Any occurrences of erosion must be attended to immediately and the integrity of the erosion control system at that point must be amended to prevent further erosion from occurring.

- If an activity will mechanically disturb the soil profile below surface, then any available topsoil should first be stripped from the entire surface to be disturbed and stockpiled for re-spreading during rehabilitation, which may be after construction or only at decommissioning. The maximum depth of topsoil stripping should be 30 cm.
- Erosion must be carefully controlled where necessary on topsoiled areas.

7.3.3.2 Operations

Loss of agricultural land use and soil degradation occur at the start of the construction phase and are therefore not listed under operational phase impacts. There is no further loss of land that occurs in subsequent phases. Potential impact on soils during the operation phase include the spillage of fuel contaminating soils.

In terms of mitigation, the following is recommended:

- Fuel storage tanks must meet international standards for structural design integrity and operational performance.
- Mitigation for spillage or leakages include the implementation of secondary containment structures e.g. bunded areas to prevent the accidental release of fuel (diesel) or LPG/ LNG.
- Spillages must be cleaned up immediately and contaminated soil must either be remediated in situ or disposed of at an appropriately licenced landfill site.

The impact is rated as being of **moderate** significance (**SP = 33**) pre-mitigation and **low** (**SP = 18**) post-mitigation.

7.3.3.3 Closure and Rehabilitation

During closure and decommissioning, soil degradation can result from erosion, topsoil loss and contamination. Erosion can occur as a result of the alteration of the land surface run-off characteristics, which can be caused by decommissioning-related land surface disturbance. Loss of topsoil can result from poor topsoil management during decommissioning related excavations. Hydrocarbon spillages from decommissioning activities can contaminate soil. Soil degradation will reduce the ability of the soil to support vegetation growth.

The impact is **low** with mitigation (**SP = 18**) and the significance can be reduced even **lower** (**SP = 12**) with the implementation of the mitigation measures provided during construction.

7.3.3.4 Cumulative

The potential cumulative agricultural impact of importance is a regional loss or degradation of agricultural land, with a consequent decrease in agricultural production. The loss of agricultural land in the area is highly likely to be within an acceptable limit in terms of loss of low potential agricultural land, of which there is no scarcity in the country.

This is particularly so when considered within the context of the following two points:

- In order for South Africa to achieve its renewable energy generation goals, agriculturally zoned land will need to be used for renewable energy generation. It is far more preferable to incur a cumulative loss of agricultural land in a region such as the one being assessed, which has no cultivation potential, and low grazing capacity, than to lose agricultural land that has a higher potential, and that is much scarcer, to renewable energy development elsewhere in the country. The limits of acceptable agricultural land loss are therefore far higher in this region than in regions with higher agricultural potential.

- It is also preferable, from an impact point of view as well as from practical considerations, to rather have a concentrated node of renewable energy development within one area, as is the case around this project, than to spread out the same number of developments over a larger area.

It should also be noted that there are few land uses, other than renewable energy, that are competing for agricultural land use in this area. The cumulative impact from developments, other than renewable energy, is therefore **low** and will not change the nature or significance of the impacts assessed in the original assessment of seven ICE.

Due to all of the considerations discussed above, the cumulative impact of loss of agricultural land use is assessed as having **low** significance.

7.3.3 Hydrogeology

7.3.4.1 Construction

The groundwater quality can be impacted by spillage of fuel and lubricants, chemicals from construction equipment, vehicles and temporary workshop during the construction phase. The impact is rated as **moderate (SP = 30)** before mitigation and **low (SP = 16)** with mitigation.

- Fuel storage tanks must meet international standards for structural design integrity and operational performance.
- Mitigation for spillage or leakages include the implementation of secondary containment structures e.g. bunded areas to prevent the accidental release of fuel (diesel).
- Spillages must be cleaned up immediately and contaminated soil must either be remediated in situ or disposed of at an appropriately licenced landfill site.
- Potentially contaminating wastes e.g. cement must be stored in bunded areas until removed by a reputable contractor for disposal at an appropriately licenced site.

Infiltration potential/ aquifer vulnerability is classified as having **low** environmental significance (**SP = 16**) before and after mitigation due to deeper groundwater level conditions which allow for a large unsaturated zone above the groundwater level which can naturally attenuate any infiltrating leakage or spills. Unsaturated flow conditions within the upper weather zone/ unsaturated zone also involves slower movement of moisture allowing for longer periods of time for natural attenuation to occur. No further mitigation is proposed.

Receptors surrounding the site are farmers who use groundwater for small-scale livestock watering purposes and the Orange River which is 15 km away from the site. Most farmers in the area use the Orange River for water supply and few groundwater users are within proximity to the site. The receptor is therefore classified as having **low** environmental significance (**SP = 12**) before and after mitigation.

7.3.4.2 Operations

The groundwater quality can be impacted by spillage of fuel (diesel), leakage from the ICE from operations and maintenance activities. The impact is rated as **moderate (SP = 30)** before mitigation and **low (SP = 16)** with mitigation. Refer to the mitigation measures proposed during the construction phase.

7.3.4.3 Closure and Rehabilitation

The groundwater impacts will be similar as for the construction phase i.e. **low (SP = 24)** before mitigation and **low (SP = 18)** with mitigation.

7.3.4 Surface Water

7.3.5.1 Construction

The proposed impact during the construction phase include:

- Spillage of fuel.
- Construction equipment, vehicles and temporary workshop areas will be a likely source of pollution as a non-point source.
- Increased run-off due to vegetation and veld removal therefore decreasing infiltration into soil which may impact on downstream communities.
- Potential pollution transport *via* run-off of rainfall from disturbed areas during construction.
- Erosion on site and surrounding areas may be increased due to site clearance of vegetation and veld.

The impact is rated as being of **moderate** significance (**SP = 30**) pre-mitigation and **low** (**SP = 16**) post-mitigation.

The following mitigation is proposed:

- Implementation of a Stormwater Management Plan (SWMP) as construction occurs.
- Place drip trays under vehicles when parked.
- Service vehicles in a dedicated workshop area.
- Spillages must be cleaned up immediately and contaminated soil must either be remediated *in situ* or disposed of at an appropriately licenced landfill site.
- Providing environmental awareness training for workers on site.

7.3.5.2 Operations

The potential surface water impact during the operations phase has been assessed as being of **moderate** (**SP = 30**) significance. The following measures are recommended to reduce the potential impact to one of **low** (**SP = 16**) significance:

- Remove settled silt from run-off control berms regularly, examine for contamination with oil and/or hydraulic fluids. Subject contaminated material to remediation or appropriate disposal in accordance with prevailing legislation. Clean silt can be used during re-vegetation of bare areas.
- Place drip trays under vehicles when parked.
- Service vehicles in a dedicated workshop area.
- The ICE infrastructure and fuel storage tanks must have overfill protection, metering and flow control, fire protection and grounding. Overfill protection equipment include level gauges, alarms and automatic cut-off systems.
- Implementation of inspection programs to maintain the mechanical integrity and operability of the ICE, tanks, piping systems, relief and vent valve systems, containment infrastructure, emergency shutdown systems, controls and pumps.
- Preparation of Standard Operating Procedures (SOPs).
- Operators must be trained on release prevention, including drills specific to hazardous materials as part of emergency preparedness response training.
- Spillages must be cleaned up immediately and contaminated soil must either be remediated *in situ* or disposed of at an appropriately licenced landfill site.

7.3.5.3 Closure and Rehabilitation

The closure and rehabilitation phase will be of shorter duration than the construction phase. The potential impacts will be similar and similar remediation measures are recommended to reduce the assessed impacts from a **low** (**SP = 27**) to a **low** (**SP = 14**) significance.

7.3.5 Ecology

7.3.6.1 Construction

Site clearance within the footprint of the development will result in a combined loss of approximately 1ha (0.5ha per ICE plant) of existing vegetation within the study area, including calcareous low shrub plains, open shrub plains and open shrub duneveld. These vegetation communities (although largely natural) were considered to be comparatively deteriorated as a result of persistent livestock grazing pressure and were ascribed a moderate ecological integrity status.

The magnitude of loss of these habitats is considered low in the context of the expansive area covered by the regional Kalahari Karroid shrubland vegetation type which supports similar habitat types and vegetation communities. The loss will be for the duration of the project until such a time as the PV plant is decommissioned and the site rehabilitated, so will be long-term in duration. This impact is largely restricted to the development footprint (areas subjected to surface clearance); the overall impact significance is therefore considered **moderate (SP = 50)**, notably as a result of the spatial restriction to moderate ecological sensitivity areas.

The significance of impacts, could be reduced to a lesser **moderate (SP = 35)** through the application of the recommended mitigation measures:

- Under no circumstances must any natural area on neighbouring properties (outside the approved development footprint) be impacted, degraded, cleared, or affected in any manner. The construction of a semi-permanent fence, which will prevent vehicle and personnel access to adjacent areas) must be constructed.
- Areas proposed for vegetation clearance must be clearly marked and no heavy vehicles should travel beyond the marked area.
- The retention of a vegetated buffer zone between the edge of the proposed infrastructure footprint and the outer boundary of the facility, within which the existing vegetation is retained, is recommended.

Exotic invasive species have been recorded within the study area; vegetation clearance works in advance of construction may create conditions that are favourable for the establishment and spread of these species to neighbouring areas, and even further afield if earth movements take place. The impact significance is **moderate (SP = 52)** prior to mitigation. An Alien and Invasive Management Programme (flora and fauna) must be developed and implemented to reduce the significance of this impact to **low (SP = 15)**.

Vegetation clearance for construction of the proposed PV plants and ICE will result in the loss/ disturbance of habitat for species of conservation concern, notably so for flora species, but also for fauna species such as Bat-Eared Fox and Cape Fox, whose prey species inhabit the vegetation within the study area for foraging and shelter. Construction activities could cause fatalities to individuals of slow-moving or burrowing species of conservation concern which may not be able to escape oncoming machinery e.g. Suricate, Karoo Round-eared Sengi, Cape Short-tailed Gerbil, and Highveld Gerbil. In addition, indirect effects due to the presence of people and heavy machinery may impact faunal species of conservation concern in the wider landscape. High fatality figures are typical for Bat-eared fox and Cape Fox that are particularly susceptible as they are nocturnal species that frequent and utilise roads during the night.

The potential impact of loss/ disturbance of species of conservation concern is assessed as **moderate (SP = 56)**, due to the confirmed presence of several species of conservation concern, and the predicted presence of several others. Anticipated impacts can be reduced to **low** significance (**SP = 36**), provided that the following recommended mitigation measures are applied:

- Prior to site clearance, a detailed 'walkthrough' must be conducted of the proposed site to ascertain the number, abundance and physical conditions of all protected tree species to assist with permit applications (DFFE).
- Prior to site clearance, a detailed 'walkthrough' must be conducted of the proposed site to ascertain the number, abundance and physical conditions of all protected plant to assist with permit applications (NCDENC).
- Targeted surveys in for resting areas/ dens of mammal species of conservation concern that are known to be present within the Study Area, such as Honey Badger, Aardvark, Striped Polecat, and Bat-eared Fox, directly in advance of clearance works to allow relocation to take place where necessary and avoid mortalities of these species.
- Strict control of vehicle movement, notably during nocturnal periods, in addition to reduced speeds, will assist in limiting accidental fatalities.
- Absolutely no animals may be hunted, trapped, snared or killed for any purpose whatsoever. Nests shall be protected, and no eggs shall be collected.

Vegetation clearance could result in direct impacts including mortality and injury of other fauna. This is considered to be an impact of **moderate (SP = 55)** before mitigation and can be reduced to a **low** significance with mitigation measures listed below in place (**SP = 27**).

- Site induction for contractors and workers must include a familiarization with all aspects relating to environmental components of the project, as well as potentially occurring dangerous animals of the area.
- Traffic speed limits of a maximum of 40 km/ hr should be imposed for all construction vehicles on all site roads and site access roads to reduce accidental animal road fatalities.

Natural habitat within the study area consists of the rocky outcrop to the north of the study area. The significance of the impact is **moderate (SP = 42)**, as although only a small area of habitat would be affected in the context of the total area of those habitat types, the good-pristine ecological integrity assigned to these areas and its classification as Natural Habitat increases the biodiversity value of these habitats. The IFC requires no net loss of Natural Habitats, therefore provided that the application of the recommended mitigation measures is adhered to, i.e. avoidance of any construction works or vegetation clearance in this habitat, plus a 250 m buffer, must be demarcated and no construction activity should occur within the demarcated zone, the predicted effects can be reduced to **low** significance (**SP = 18**).

7.3.6.2 Operations

The spread of invasive species, particularly invasive plant propagules by heavy machinery and earthworks could cause an impact of **moderate** significance (**SP = 52**), depending on the invasive plant species that occur in the area. The continuation of the Alien and Invasive Management Programme established during construction is critical in ensuring an impact of **low** significance (**SP = 15**) post-mitigation.

Increased vehicular traffic in the study area during the operation of the PV plant including ICE is likely to result in increased incidences of road -kill, particularly at night. Magnitude in this case refers to the number of wildlife road deaths, which is considered to be potentially high. The impact would be long-term and would affect wildlife on a local scale with an estimated high probability of occurrence, resulting in an impact of **moderate** significance (**SP = 70**). Although the application of mitigation measures listed below would reduce the number of road-kill deaths and the probability of vehicle-animal collisions happening, the impact remains one of **moderate** significance (**SP = 40**) post-mitigation.

- The persistence of opportunistic animal species within the development footprint and appurtenant infrastructure must be monitored and discouraged.

- Information signs regarding animals that may crossroads, notably during nocturnal periods, must be erected at selected localities. Monitoring of road conditions will inform of sites where burrows are observed.

Based on observations of the Bokpoort I plant, the PV plants including ICE will be well-lit at night. In addition, frequent security patrols of the boundary throughout the day were observed. These, together with on-going operation and maintenance activities at the facility, are expected to cause disturbance to faunal species of conservation concern in surrounding areas, particularly at night-time. The magnitude of the effects is expected to be moderate given the extent of lighting observed at the existing facility. The predicted impact is thus considered to be of **moderate** significance (**SP = 60**) prior to mitigation. A key mitigation measure is minimising the use of floodlight and high intensity lighting during the night. Where unavoidable, lights should be mounted as low as possible and fully shielded where possible. Beams must be directed only to areas where it is needed (avoid peripheral light). Once the recommended mitigation measures are applied, the magnitude of effects on bats and the probability of effects on other faunal species (some of the more adaptable fauna species e.g. foxes may become accustomed to a certain level of disturbance over time) can be reduced, reducing the significance of the overall impact to **low** (**SP = 20**).

Security fencing on the perimeter of the development compound will present a barrier to movement for mammal species of conservation concern such as Aardvark, Bat-eared Fox and Honey Badger, as well as larger reptiles. This may reduce mammal movement capability through the landscape, forcing affected species to make longer, more energetically-expensive journeys to get around the fenced areas. The overall significance of impact is considered to be **moderate** (**SP = 48**). It is difficult to mitigate the presence of the security fence during the lifetime of the project; however, periodic (weekly) monitoring survey of all fences to identify and remove snares when observed may result in a **low** impact (**SP = 36**).

7.3.6.3 Closure and Rehabilitation

The spread of invasive species, particularly invasive plant propagules by heavy machinery and earthworks could cause an impact of **moderate** significance (**SP = 65**), depending on the invasive plant species that occur in the area. The Alien and Invasive Management Programme must be continued in all stages of the development. Ongoing monitoring must be conducted by the ECO and periodic monitoring (annual) by a qualified ecologist to ascertain the efficacy of the programme. This impact is rated **low** (**SP = 21**) post-mitigation.

7.3.6.4 Cumulative

Potential residual (post-mitigation) impacts of the PV plants including the ICE that may contribute to the cumulative effects of other proposed and permitted solar developments in the region relate to exacerbated direct and indirect impacts on fauna, such as increased incidences of road-kill as a result of the increase in traffic on a regional scale and the continued loss of remaining areas of natural habitat and changes to the landscape that affect migration patterns.

From a floristic perspective, the continued and incremental loss of natural habitat is an important consideration. Additionally, the exponential increase in population often result in exacerbation of harvesting and utilisation patterns. Because of the comparatively small size of the proposed development, the significance of anticipated cumulative impacts is expected to be of a **low** significance. Similarly, since the proposed development represents an extension of the existing development, the cumulative exacerbation of identified impacts on a regional scale is anticipated to be minimal.

7.3.6 Bats

7.3.8.1 Construction

Negative impacts during the construction phase pertain to the clearance of indigenous vegetation from the development area. The vegetation clearing will cause habitat loss and fragmentation, reducing the foraging habitat available to bats in this area. The natural functioning of the ecosystem of the development footprint will be permanently altered. This impact has a pre-mitigation significance rating of **moderate (SP = 55)** that is reduced to **low** significance (**SP = 28**) with mitigation measures.

Construction activities and lighting of the site may cause disturbance and displacement whereby bats will no longer utilize the area and the bat community in the greater area may be altered. If bats have taken to roosting within the more recently built houses/ buildings on site, traffic and construction noise may be a disturbance to them. This impact has a pre-mitigation rating of **moderate (SP = 36)** that is reduced to **low** significance (**SP = 24**) with mitigation measures.

The following mitigation measures are proposed:

- Vegetation clearance and disturbance of topsoil must be limited to developable areas and minimized as much as possible. Areas to be cleared must be clearly delineated and movement of vehicles should be limited to these areas.
- Upon completion of construction, vegetation rehabilitation must be carried out in areas that were disturbed during construction if the ground surface is no longer in use for the operation of the plants.
- Construction activities must be reduced as much as possible during the night to limit noise and light disturbance to bats.
- If nocturnal lighting is required during construction, it should be directed and limited to work areas to prevent light spillage.
- If feasible, warm LED bulbs should be used for site lighting to limit the attraction of insects to the light and in turn prevent a shift in the bat community present in the area.

7.3.8.2 Operations

Security lighting of the infrastructure at night will alter the natural bat community in the area as some species actively forage on insects attracted to light, while other species are deterred from the area by the light. These above-mentioned impacts have a pre-mitigation **moderate** significance rating (**SP = 52**) that is reduced to **low** significance (**SP = 27**) with application of mitigation measures.

Change of bat community utilizing development area due to security lighting is rated as a **moderate** significance (**SP = 44**) before mitigation and **low (SP = 28)** post-mitigation.

Collision of bats with PV panels and infrastructure has been assessed as having a **low** pre-mitigation significance rating (**SP = 12**) and **low (SP = 6)** with mitigation, as bats are not likely to mistake panels as water sources and will typically utilize their established drinking sources. Additionally, bats should quickly learn that the panels are not water sources and leave the area to search for water elsewhere.

The following mitigation measures are proposed:

- Lighting of the site during operation must also be directional and limited to only the necessary areas to prevent light spillage, and warm LED bulbs should be used.
- Searches for bat carcasses on the ground around the project area must be conducted in tandem with searches for bird carcasses. The ECO must freeze bat carcasses and keep a record of the location, date and time of when it was found.

7.3.8.3 Closure and Rehabilitation

The negative impact of disturbance and displacement may result from decommissioning activities due to noise, vehicles moving through the site and additional lighting of the area. This impact has a pre-mitigation **moderate** significance rating (**SP = 36**) that is reduced to **low** significance (**SP = 24**) with mitigation measures.

The following mitigation measures are proposed

- Decommissioning activities must be reduced as much as possible during the night to limit noise and light disturbance to bats.
- If nocturnal lighting is required during decommissioning, it must be directed and limited to work areas to prevent light spillage and warm LED bulbs should be used.
- Upon completion of decommissioning, vegetation rehabilitation should be carried out over the site to re-establish the natural ecosystem functioning of the development footprint and restore the use of the area by bats.

7.3.8.4 Cumulative

The proposed PV plant developments as well as planned solar projects in the area above will primarily negatively impact bats by reducing foraging areas and roosting resources within the greater area. However, the Orange River and its riparian vegetation is a more important source of drinking water and prime foraging grounds for bats than the surrounding areas that the proposed projects are located within. It is essential for each facility to apply site-specific mitigation measures recommended by relevant specialists to mitigate the cumulative impacts of renewable energy developments in the region. The outlined mitigation measures listed above of must be adhered to, to reduce cumulative impacts of development in the greater area.

7.3.7 Avifauna

7.3.7.1 Construction

Habitat destruction – the proposed project will impose a risk to birds through habitat destruction as clearing activities during the construction phase will remove vegetation and therefore habitat that birds require for breeding, foraging and roosting.

The impact is rated as **moderate (SP = 70)** without mitigation and **moderate (SP = 60)** with mitigation. The proposed mitigation measures are provided below:

- A site-specific EMPr must be implemented, which gives appropriate and detailed description of how construction activities must be conducted to reduce unnecessary destruction of habitat.
- High traffic areas and buildings such as offices, batching plants, storage areas etc. must, where possible be situated in areas that are already disturbed.
- Existing roads and farm tracks must be used where possible.
- The minimum footprint areas of infrastructure should be used wherever possible, including road widths and lengths.
- No off-road driving must be allowed.
- Following construction, rehabilitation of areas underneath the solar panels and those disturbed, must be undertaken.

Disturbance and displacement - the proposed project imposes a risk of temporary or permanent disturbance and displacement of birds due to construction activities. The significance rating of this impact before mitigation is **moderate (SP = 48)** and is reduced to **moderate (SP = 30)** after mitigation.

The proposed mitigation measures are provided below:

- Prior to construction, an avifaunal specialist must conduct a site walkthrough to identify any nests/ breeding/ roosting activity of sensitive species, as well as any additional sensitive habitats. The results of which may inform the final construction schedule in close proximity to that specific area, including abbreviating construction time, scheduling activities around avian breeding and/ or movement schedules, and lowering levels of associated noise.
- The appointed ECO must be trained by an avifaunal specialist to identify the potential Red Data species as well as the signs that indicate possible breeding by these species.
- The ECO must then, during audits/ site visits, make a concerted effort to look out for such breeding activities of Red Data species, and such efforts may include the training of construction staff (e.g. in Toolbox talks) to identify Red Data species, followed by regular questioning of staff as to the regular whereabouts on site of these species.
- If any of the Red Data species are confirmed to be breeding (e.g. if a nest site is found), construction activities within 500 m of the breeding site must cease, and an avifaunal specialist must be contacted immediately for further assessment of the situation and instruction on how to proceed.
- No construction activities or staff are permitted within 1.5 km of the identified Martial Eagle nest buffer.
- A construction phase bird monitoring programme must be implemented by an avifaunal specialist, to document potential impacts on key species such as korhaans, bustards and eagles, and must include the ongoing monitoring of the active Verreaux's Eagle and Martial Eagle nest sites.

7.3.7.2 Operations

Disturbance and displacement - the proposed project imposes a risk of disturbance and displacement of birds due to ongoing operational and maintenance activities. The significance rating of this impact before mitigation is **moderate (SP = 56)** and is reduced to **low (SP = 24)** after mitigation.

The following mitigation measures are proposed:

- A site-specific operational EMPr must be implemented, which gives appropriate and detailed description of how operational and maintenance activities must be conducted to reduce unnecessary disturbance.
- All contractors must adhere to the EMPr and should apply good environmental practice during all operations.
- The on-site operational facilities manager (or a suitably appointed Environmental Manager) must be trained by an Avifaunal Specialist to identify the potential Red Data species as well as the signs that indicate possibly breeding by these species.
- If a priority species or Red Data species is found to be breeding (e.g. a nest site is located) on or within 2 km of the operational facility (or the grid connection servitude), the nest/ breeding site must not be disturbed and the avifaunal specialist must be contacted for further instruction.
- Operational phase bird monitoring, in line with the solar guidelines, must be implemented.
- No operational activities or staff are permitted within 1.5 km of the identified Martial Eagle nest.

Collision with infrastructure - the proposed PV developments including the addition of the ICE may impose an increased risk of collision for small birds due to an increased area of panels associated with PV technology and a potentially increased 'lake effect'. The collision risk of the proposed project should therefore largely be confined to the site itself as the risk to birds commuting at higher altitude across the project site would be low. The significance rating of this impact is **moderate (SP = 55)** before mitigation and **low (SP = 27)** after mitigation.

Proposed mitigation includes the following:

- All artificial water points (e.g. livestock water points and wind pumps) on the project site and within 500 m from the boundary of the project site, must be moved or shut down (if not already removed from

the project site during construction) so that birds are not attracted to the project site and immediate surrounding areas.

- All water-related infrastructure (e.g. pipes, pumps, reservoirs, toilets, taps etc.) must be regularly (twice weekly) checked for leaks, and repaired immediately.
- Lighting should be kept to a minimum to avoid attracting insects and birds and light sensors/ switches should be utilised to keep lights off when not required.
- Lighting fixtures should be hooded and directed downward where possible, to minimize the skyward and horizontal illumination, lighting should be motion activated where possible.
- Careful selection of and modifications to solar facility equipment should be made where possible e.g. white borders could be applied to PV panels to reduce the resemblance of solar arrays to waterbodies.
- Driving at night should be avoided where possible and speed limits of 40 km/ h for refuelling tankers must be strictly enforced along all gravel roads to the facility to reduce collisions as well as unnecessary dust and noise. Further speed limit restrictions of 20 km/ h for refuelling tankers must be strictly enforced within all nest buffer areas.
- Develop and implement an operational monitoring programme for birds in line with applicable solar guidelines, which must include searching for mortalities.
- Frequent and regular review of operational phase monitoring data and results by an avifaunal specialist.
- If unacceptable impacts are observed (in the opinion of the bird specialist and independent review), the specialist must conduct a literature review specific to the impact and provide updated and relevant mitigation options to be implemented.

Disruption of bird movement patterns - utility scale solar energy facilities may form a physical barrier to movement of birds across the landscape, and this may alter migration routes and increase distances travelled and energy expenditure or block movement to important areas such as hunting and foraging areas. The significance rating of this impact before mitigation is **moderate (SP = 39)** and is reduced to **low (SP = 20)** after mitigation.

The following mitigation measures are prescribed:

- Where not prescribed by technical or local and international requirements, external lighting must be of an intermittent and coloured nature rather than constant white light to reduce the potential impact on the movement patterns of nocturnal species. Habitat rehabilitation and promoting the regrowth of natural vegetation below the solar panels would reduce the barrier effect to some bird species reluctant to cross unsuitable habitat or cleared vegetation, such as francolins.
- Perimeter fencing must be designed to prevent entrapment of large bodied species such as korhaans between fence rows, giving them sufficient space for take-off, i.e. if a double-layer of parallel fencing is used, the gap between the fences should be large enough to allow for large birds to take-off and leave the area. Where this would result in unacceptable compromises to the security of the site, large-bodied birds should be prevented from entering the gaps between parallel fence rows. Perimeter fence design to be done in consultation with an avifaunal specialist.
- Markers or panel gaps on solar panels to break-up reflections and reduce the 'lake effect'.

7.3.7.3 Cumulative

Approximately 16 solar energy projects in various stages of the EIA application process fall within this 50 km radius of the project site. Should 50% or more of these projects be constructed the cumulative impact of the residual impacts may have a **high** significance. It is difficult to say with high confidence at this stage what the cumulative impact of all the proposed developments will be on birds as the specifics of the final technologies to be utilised at each site, and levels of habitat rehabilitation within the project sites, is unknown. The cumulative impact will be significantly reduced to **moderate** if the mitigation measures are implemented at all surrounding developments.

7.3.8 Air Quality

7.3.8.1 Construction

The construction phase of the generator sets will result in emission of particulate matter, and to a lesser extent, gaseous pollutants. Ambient pollutant concentrations and nuisance dustfall rates will increase during the construction (and decommissioning) periods. The impact is likely to be localised near construction activities. With mitigation, off-site exceedances are not expected. The impact is rated as having a **low** impact (**SP = 15**) without mitigation and **low** (**SP = 12**) with mitigation.

The following mitigation measures are proposed:

- Construction-phase mitigation measures as per the recommendations made in the Bokpoort 10 x PV solar power plant Air Quality Impact Assessment⁸¹.
- Establish a Complaints Register, during construction.
- Fence-line monitoring of dustfall in accordance with the National Dust Control Regulations.

7.3.8.2 Operations

Impact of the operational phase was simulated using the parameters and emission rates given in Section 4 (Table 4-1, Table 4-2, Table 4-4, and Table 4-5) of the Atmospheric Impact Report – **Appendix C4**. Short-term (hourly or daily) concentrations were extracted at the 99th percentile, to account for the number of exceedances allowed by the NAAQS.

- **Simulated Incremental SO₂ Impacts**

The simulated SO₂ concentrations associated with normal operation of the project were below the hourly (Figure 32) and daily (Figure 33) National Ambient Air Quality (NAAQ) limit values on- and off-site and at all receptors. Annual concentrations were also simulated to be lower than the respective NAAQS (Figure 34).

⁸¹ Ramsay, L. 2020. Air Quality Impact Assessment for Proposed Bokpoort 10 x PV Solar Power Facilities; Farm Bokpoort, near Goblershoop, Northern Cape Province. Durban: WSP for Royal HaskoningDHV.

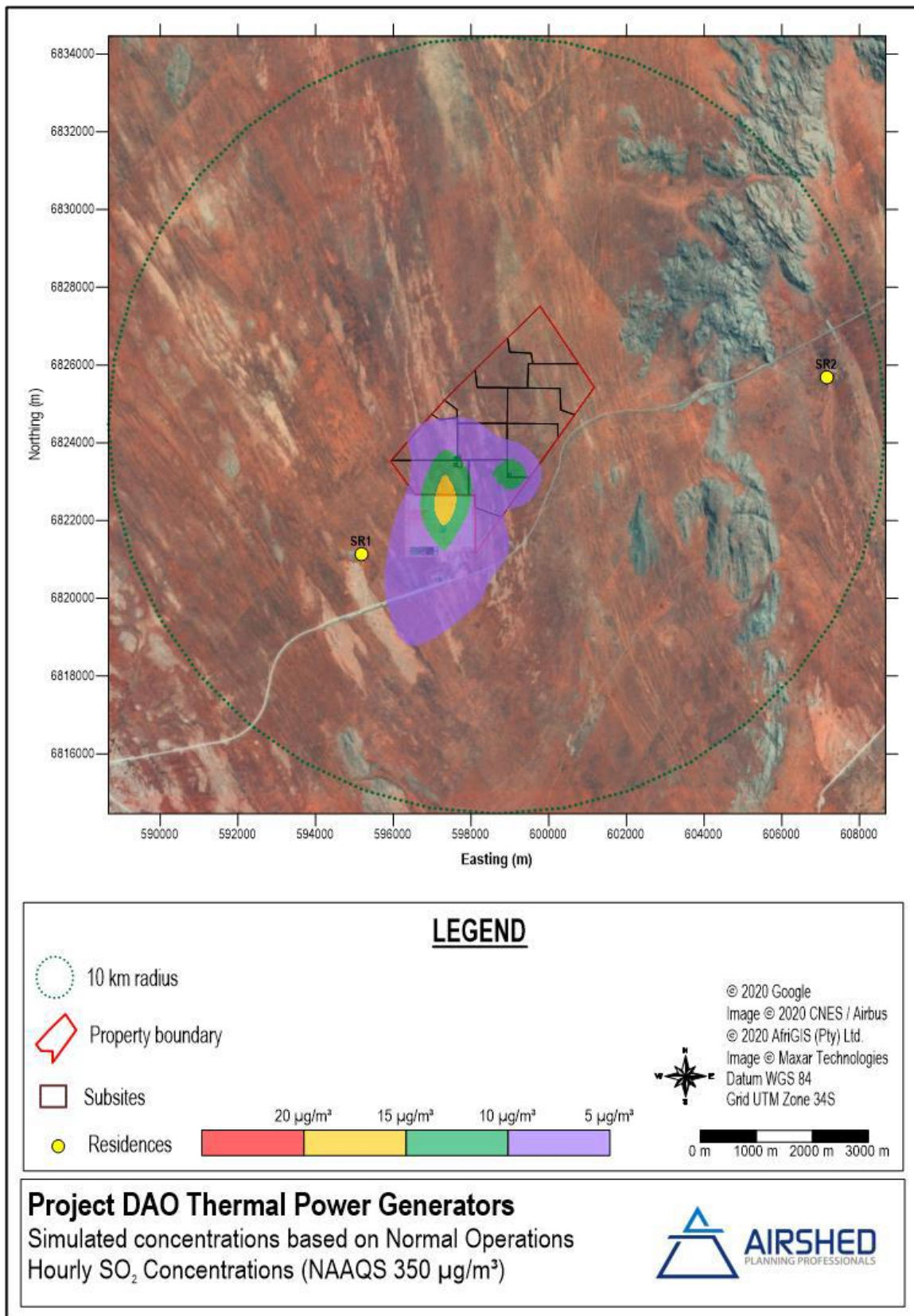

Figure 32: Simulated hourly average ambient SO₂ concentrations

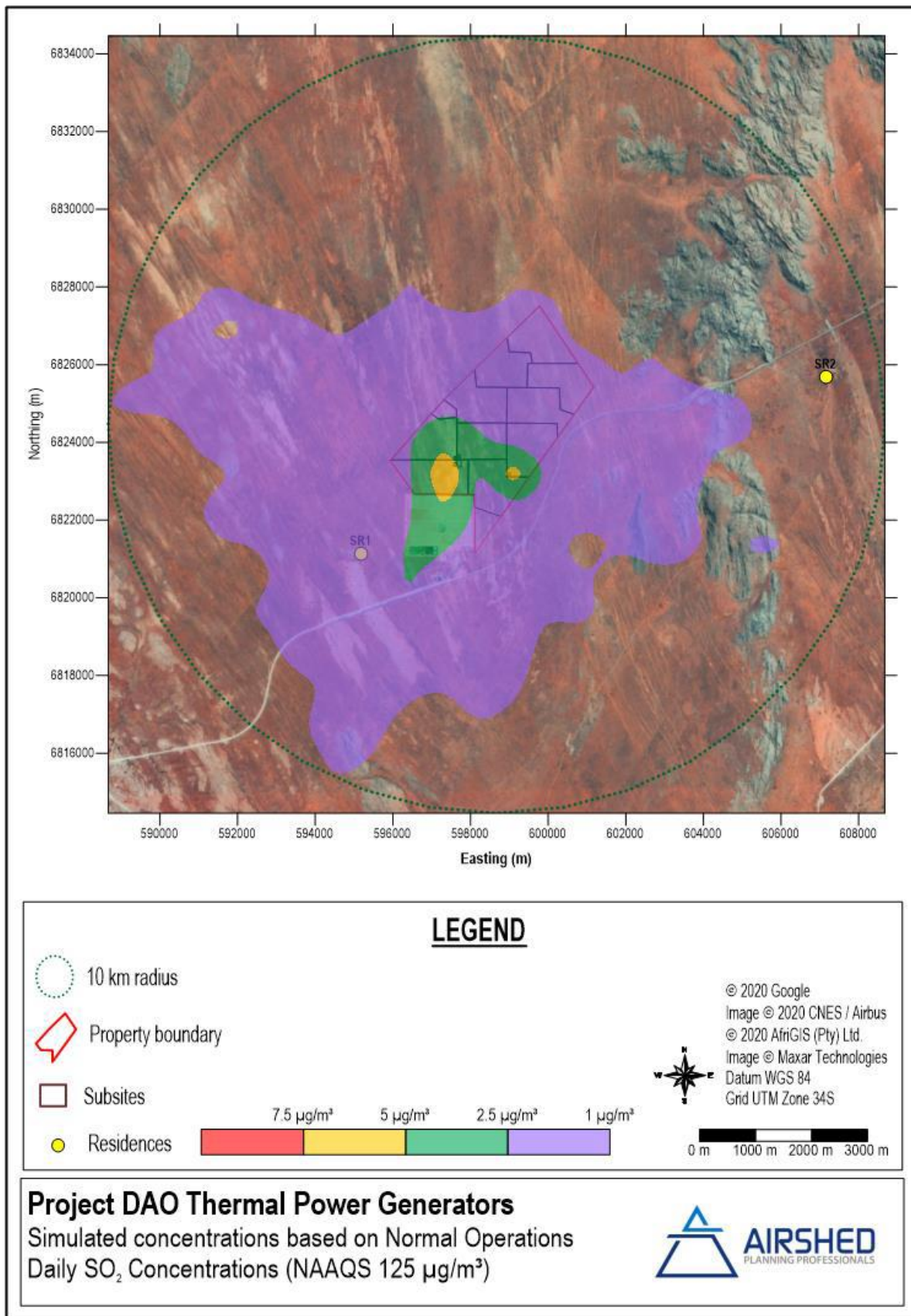

Figure 33: Simulated daily average ambient SO₂ concentrations

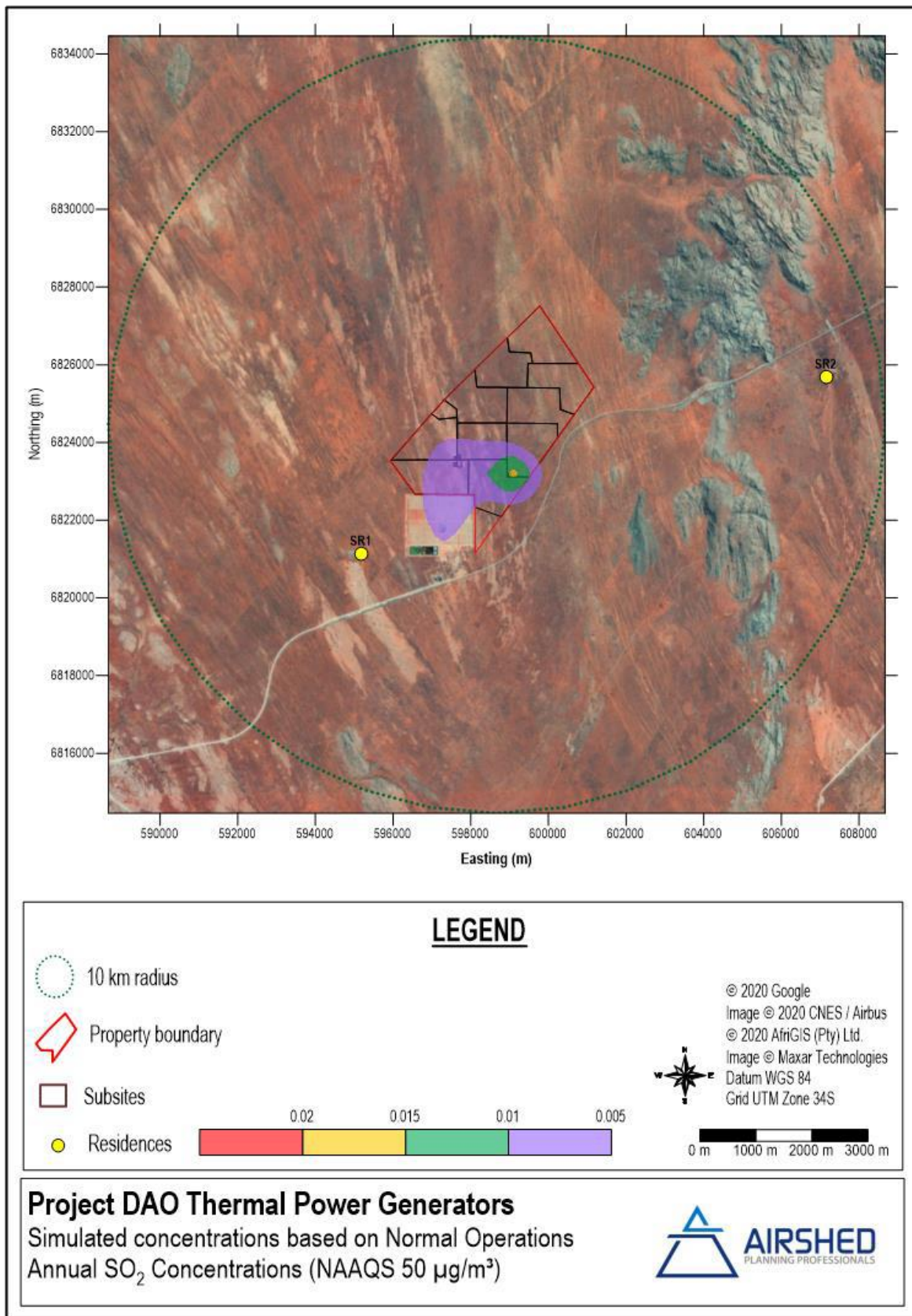

Figure 34: Simulated annual average ambient SO₂ concentrations

- **Simulated Incremental NO₂ Impacts**

Simulated (worst-case) hourly NO₂ concentrations could exceed the NAAQ limit concentration up to 1.9km to the south of the project boundary, (Figure 36). Simulated hourly average NO₂ concentrations are likely to be near 100µg/m³ at the nearest receptor (SR1 - Figure 36), where the frequency of exceedance of the NAAQ limit was calculated to be at maximum 35 hours per year (data not shown), where 88 hours of exceedance are allowed per year. Simulated annual average NO₂ concentrations are lower than the NAAQS across the domain, with a domain maximum less than 2µg/m³ (Figure 36).

To identify the potential impact of the project on the ambient NO₂ concentrations during the reliability test, all 56 engines were assumed to run simultaneously over the entire meteorological period (2017 to 2019) and NO₂ concentrations at the nearest receptor were simulated. From an air quality perspective, the months of April to July are when dispersion conditions are least favourable and are most likely to result in the most frequent exceedances of the hourly NAAQ limit concentration at the closest sensitive receptor (SR1 - Table 40). The months of August to November (as late winter and spring) provide atmospheric conditions that are more suitable for pollutant dispersal and, therefore, lower pollutant concentrations at the closest sensitive receptor (SR1 - Table 40).

Table 40: Simulated NO₂ impact at the closest sensitive receptor for continuous operation of the generators during the 15-day reliability test

Parameter	Jan	Feb	Mar	Apr	May	Jun	Jul	Aug	Sep	Oct	Nov	Dec
Hours exceeding 200µg/m ³	3	2	4	10	8	9	5	5	5	4	1	1

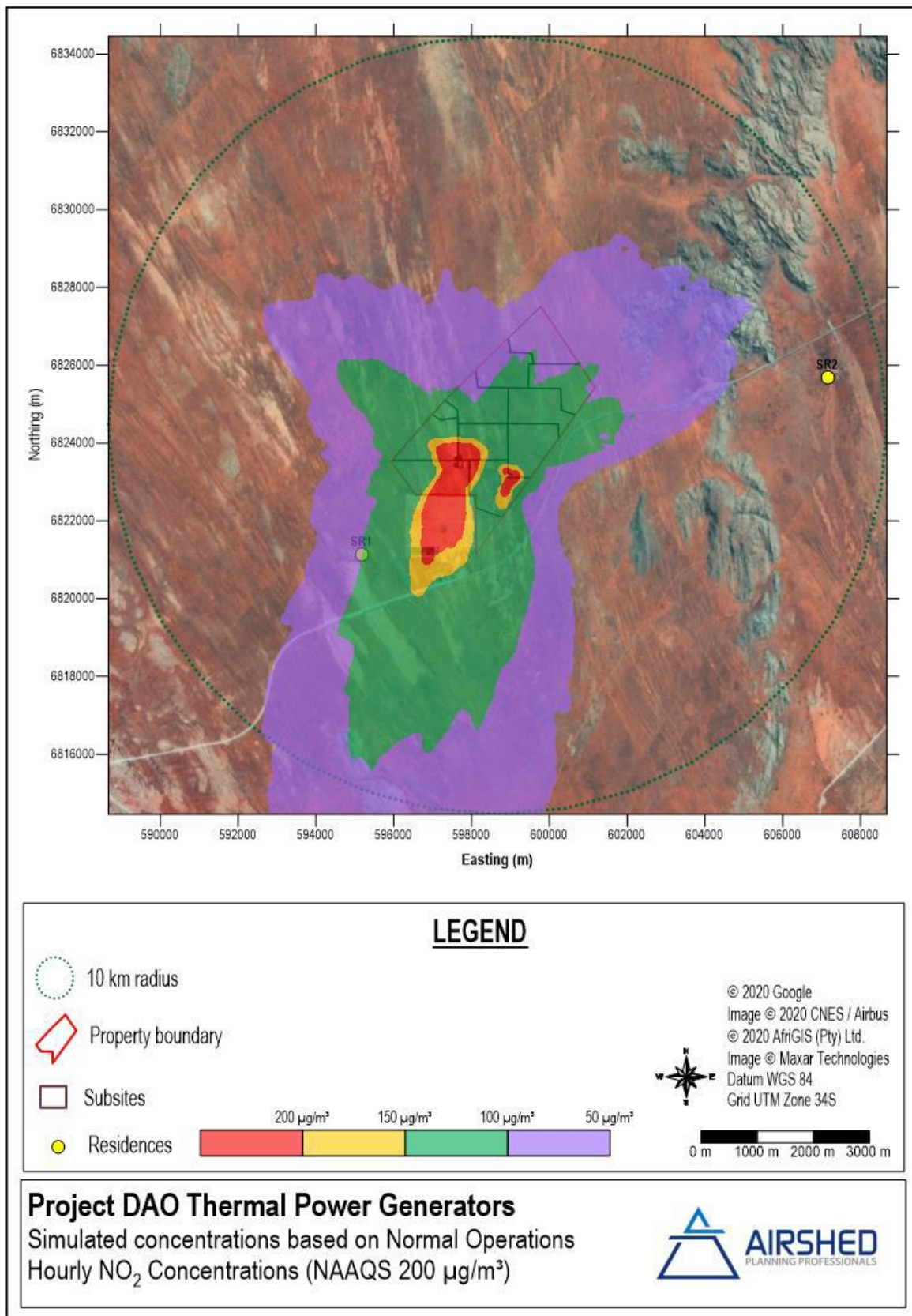

Figure 35: Simulated hourly NO₂ concentrations

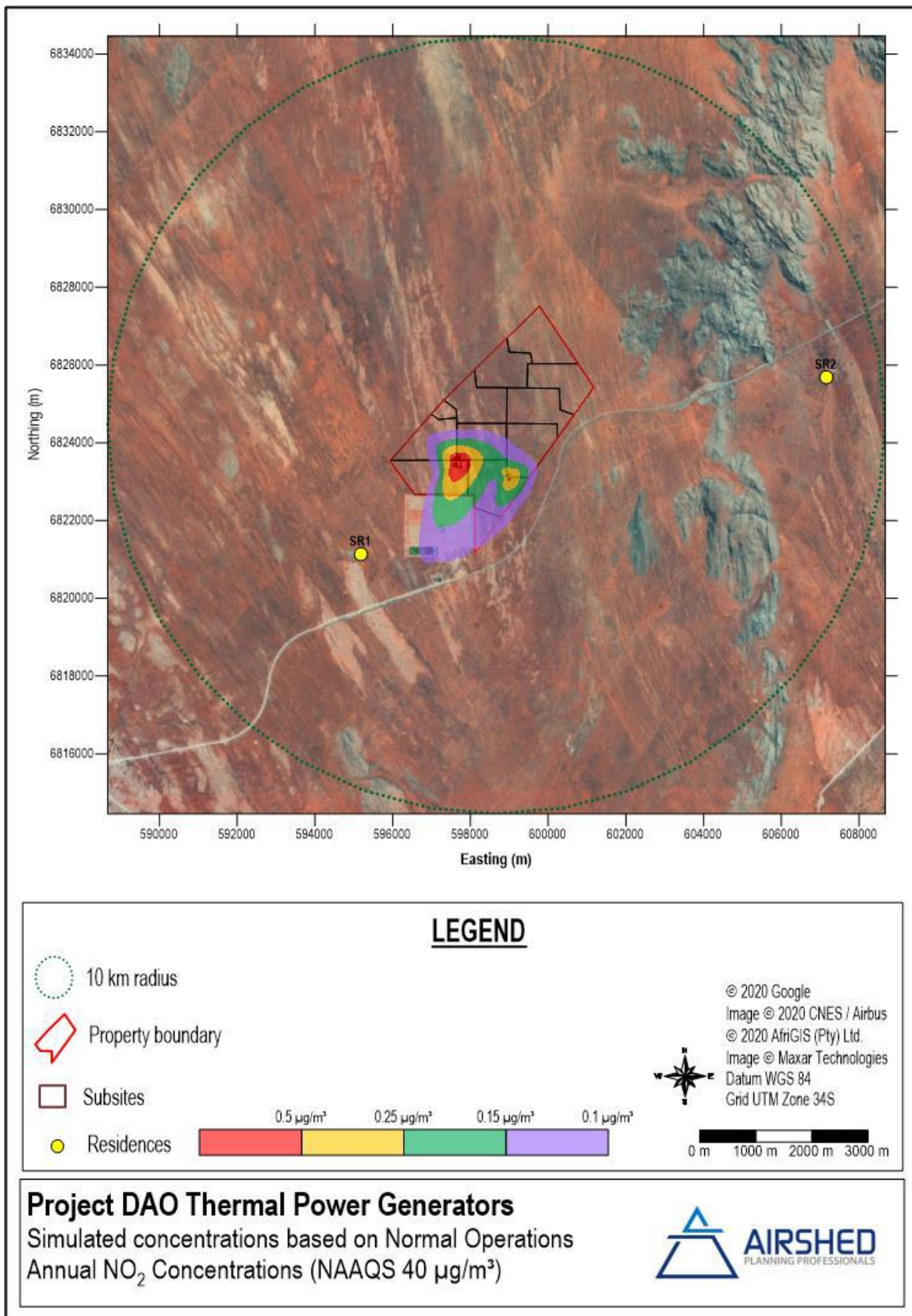

Figure 36: Simulated annual average ambient NO₂ concentrations

- ***Simulated Incremental Particulate Matter Impacts***

Simulated particulate matter concentrations, in both the PM₁₀ and PM_{2.5} fractions, as a result of the project were in below all the respective NAAQS at all receptors and across the entire domain (Figure 37 to Figure 40).

Simulated annual PM_{2.5} concentrations are below the chronic inhalation criterion for diesel particulate matter (DPM) across the domain (Figure 40) - where the criterion is 5µg/m³ and concentrations are lower than 0.1µg/m³ off-site). Excess life-time cancer risk due to exposure to DPM were calculated to be “Very low” at the closest receptors (Table 41). Across the domain the risk was calculated to be “Low” within 1.2km south of the project boundary and “Very low” elsewhere (Figure 41).

Table 41: Incremental life-time cancer risk at the closet receptor due to exposure to DPM

ID	Annual DPM concentration (PM2.5)	Excess life-time cancer risk ratio	Qualitative Descriptor
SR01	0.0012	3.53x10 ⁻⁰⁷	Very low
SR02	0.0006	1.66x10 ⁻⁰⁷	Very low

- ***Simulated Incremental CO Impacts***

Simulated hourly CO concentrations as a result of the project are lower than the NAAQ limit values at receptors and across the entire domain (Figure 42).

- ***Simulated Incremental VOC Impacts***

Simulated hourly VOC concentrations across the domain as a result of the project are lower than the international health criteria (200µg/m³) selected for the project (Figure 43). If all VOCs were conservatively assumed to be benzene – which is unlikely given the low benzene contents typical of diesel – off-site concentrations would comply with the annual benzene NAAQS.

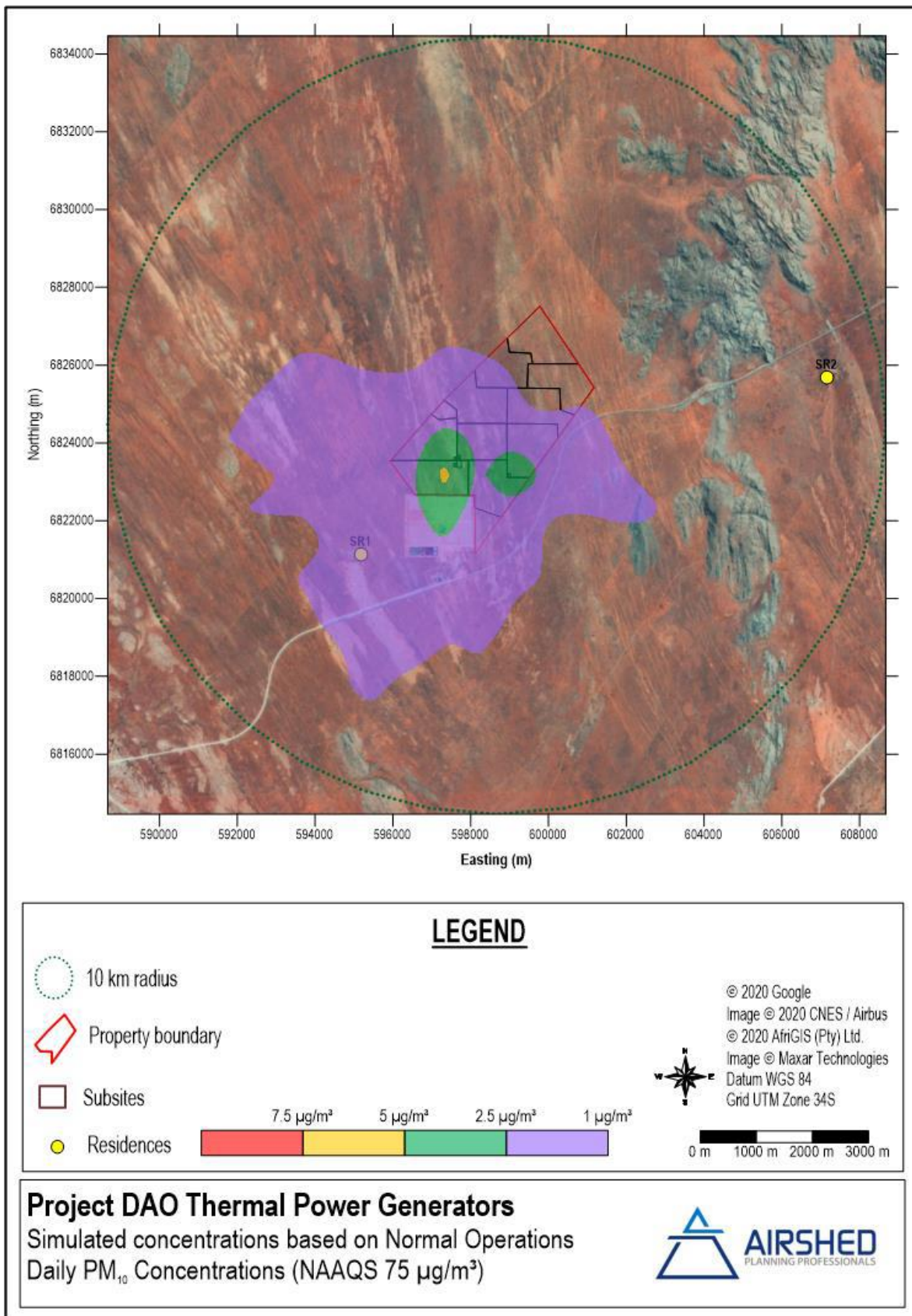

Figure 37: Simulated daily average ambient PM₁₀ concentrations

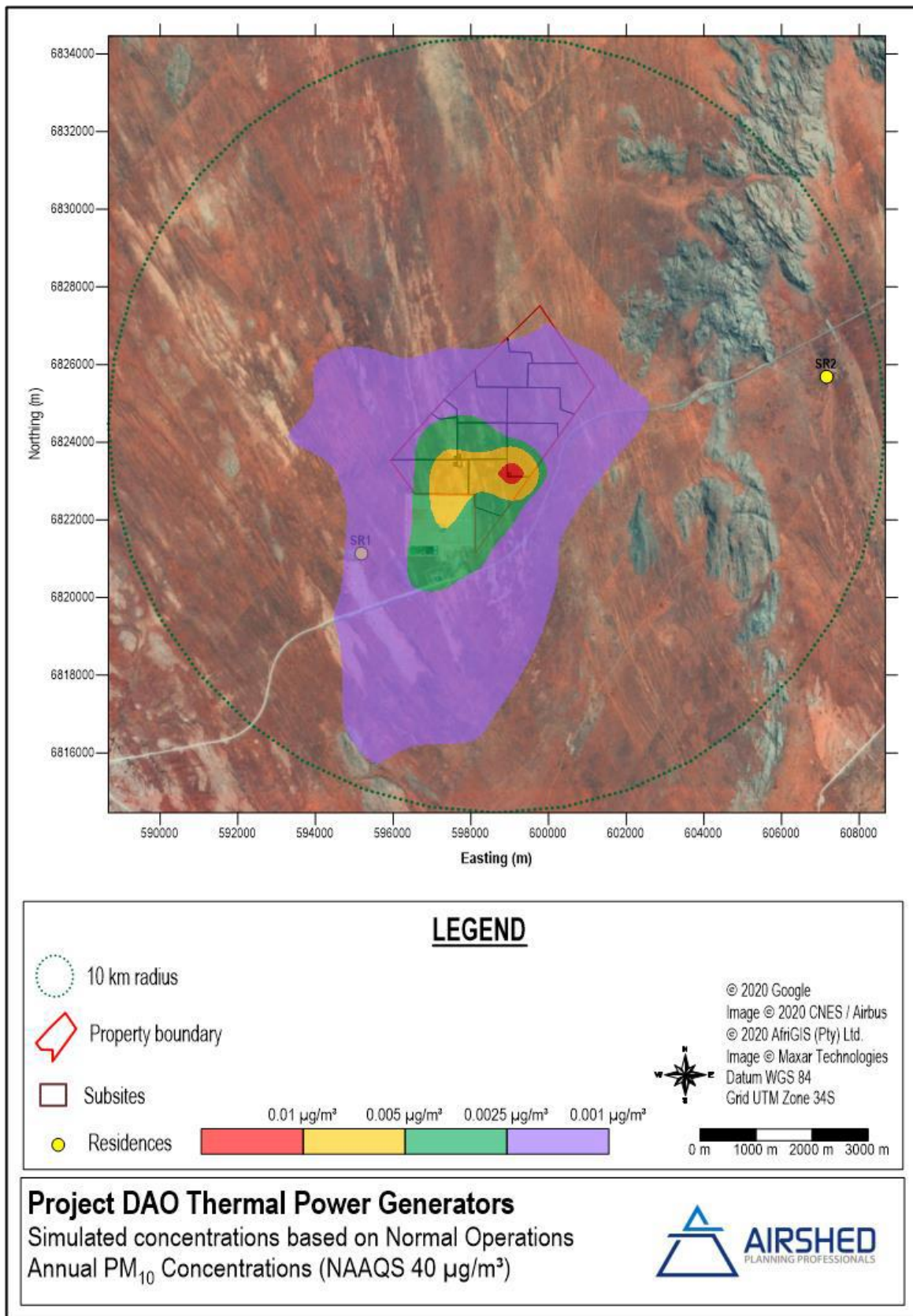

Figure 38: Simulated annual average ambient PM₁₀ concentrations

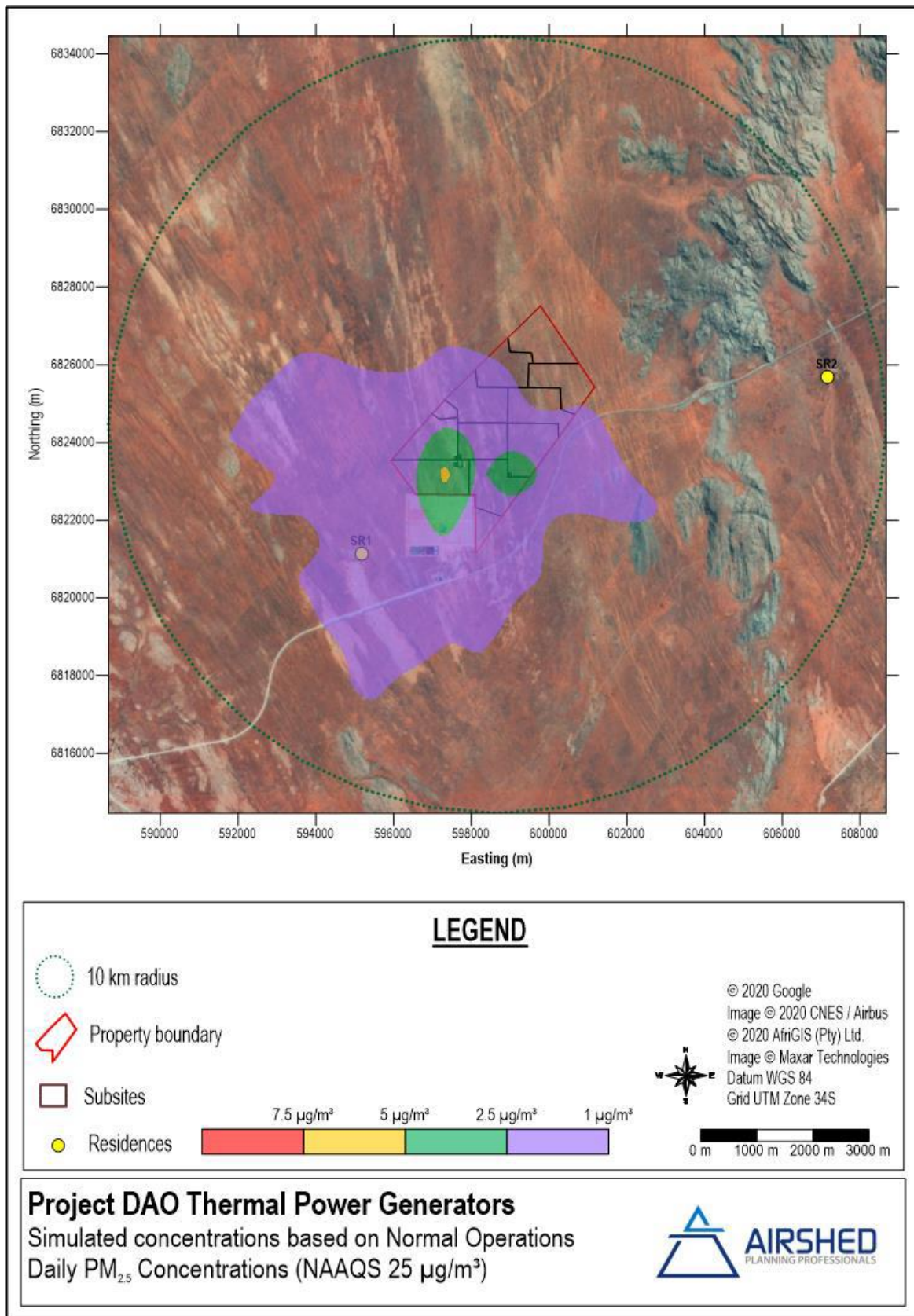

Figure 39: Simulated daily average ambient PM_{2.5} concentrations

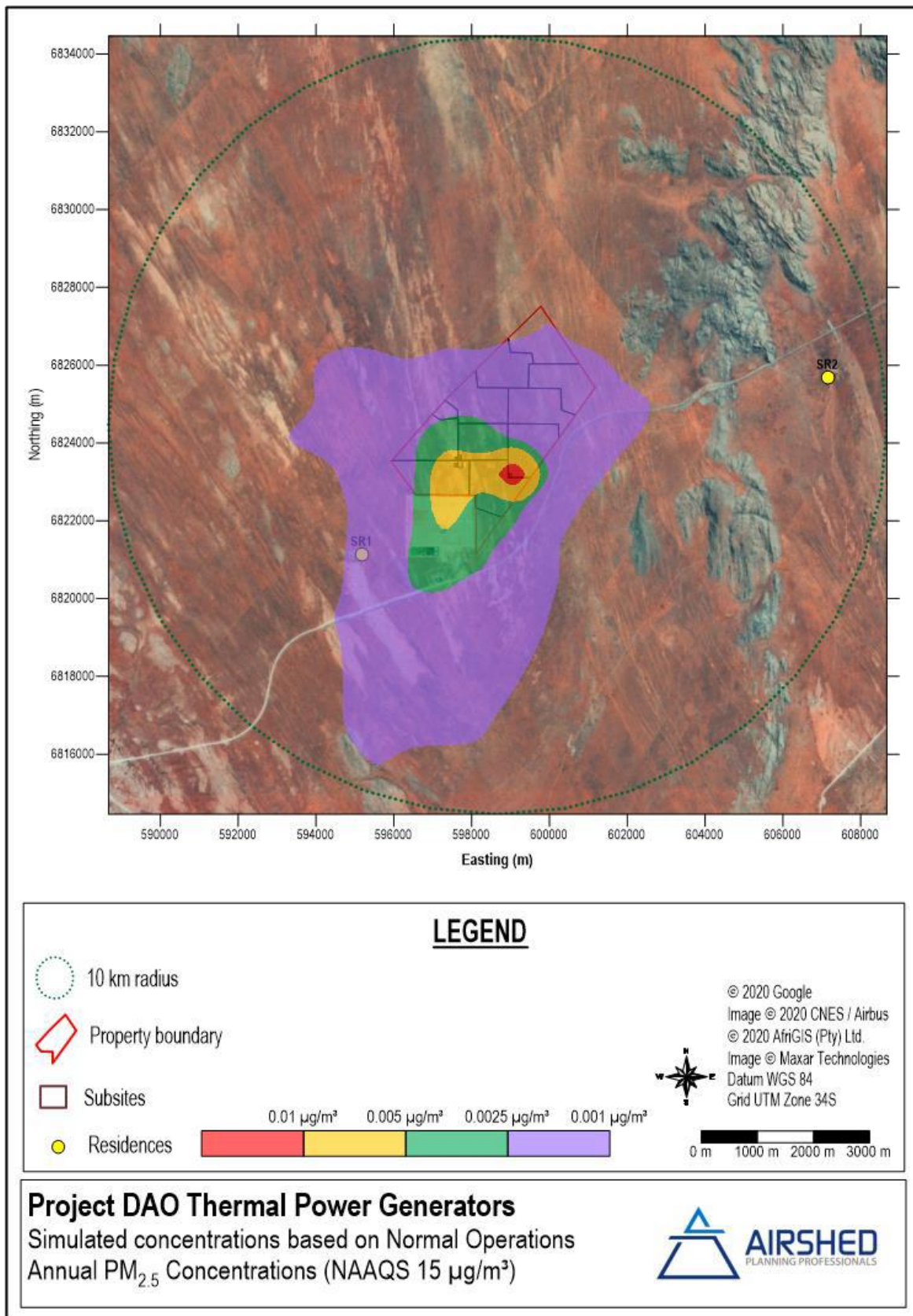

Figure 40: Simulated annual average ambient PM_{2.5} concentrations

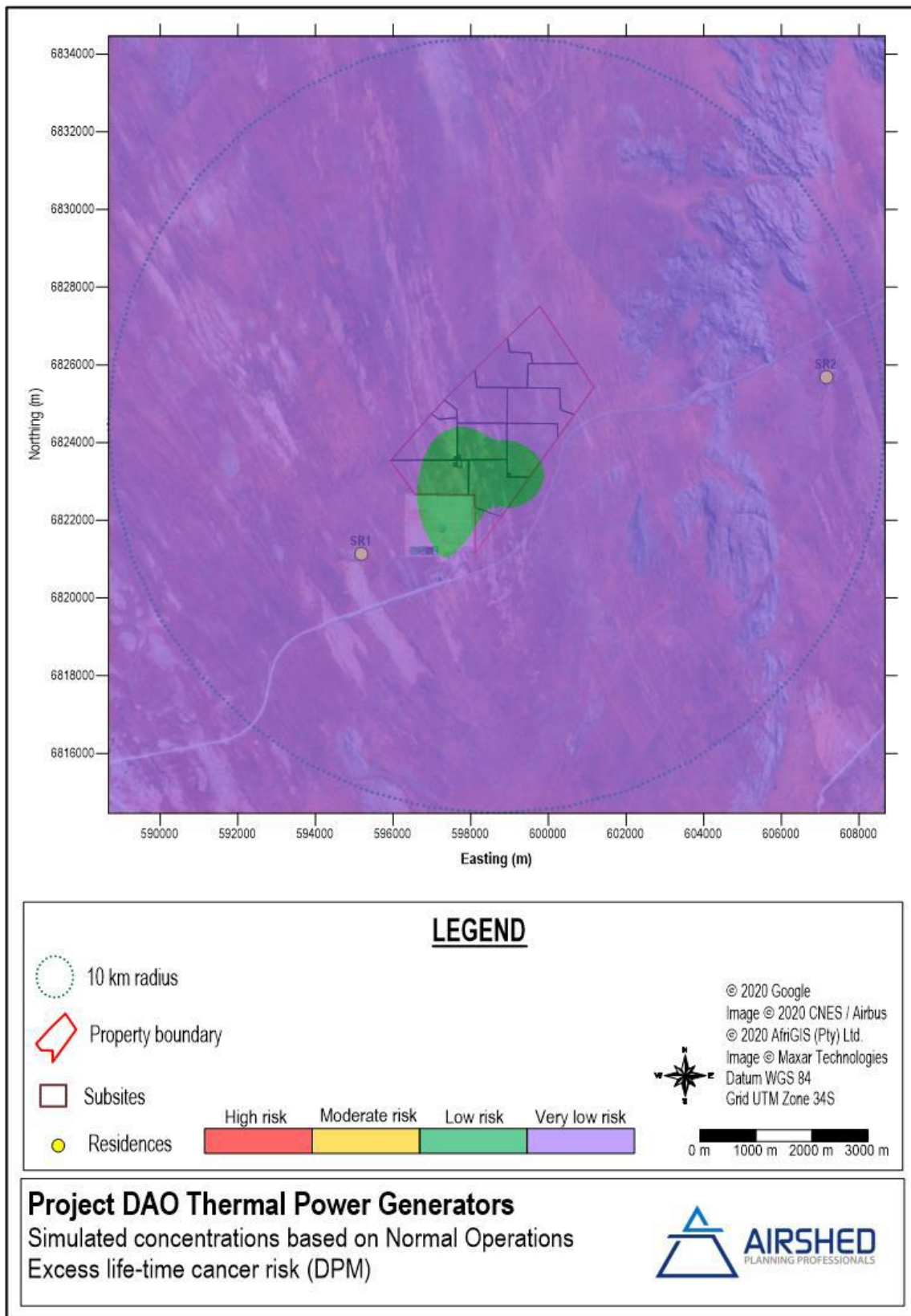

Figure 41: Simulated excess life-time cancer risk due to exposure to DPM (based on annual PM_{2.5} concentrations)

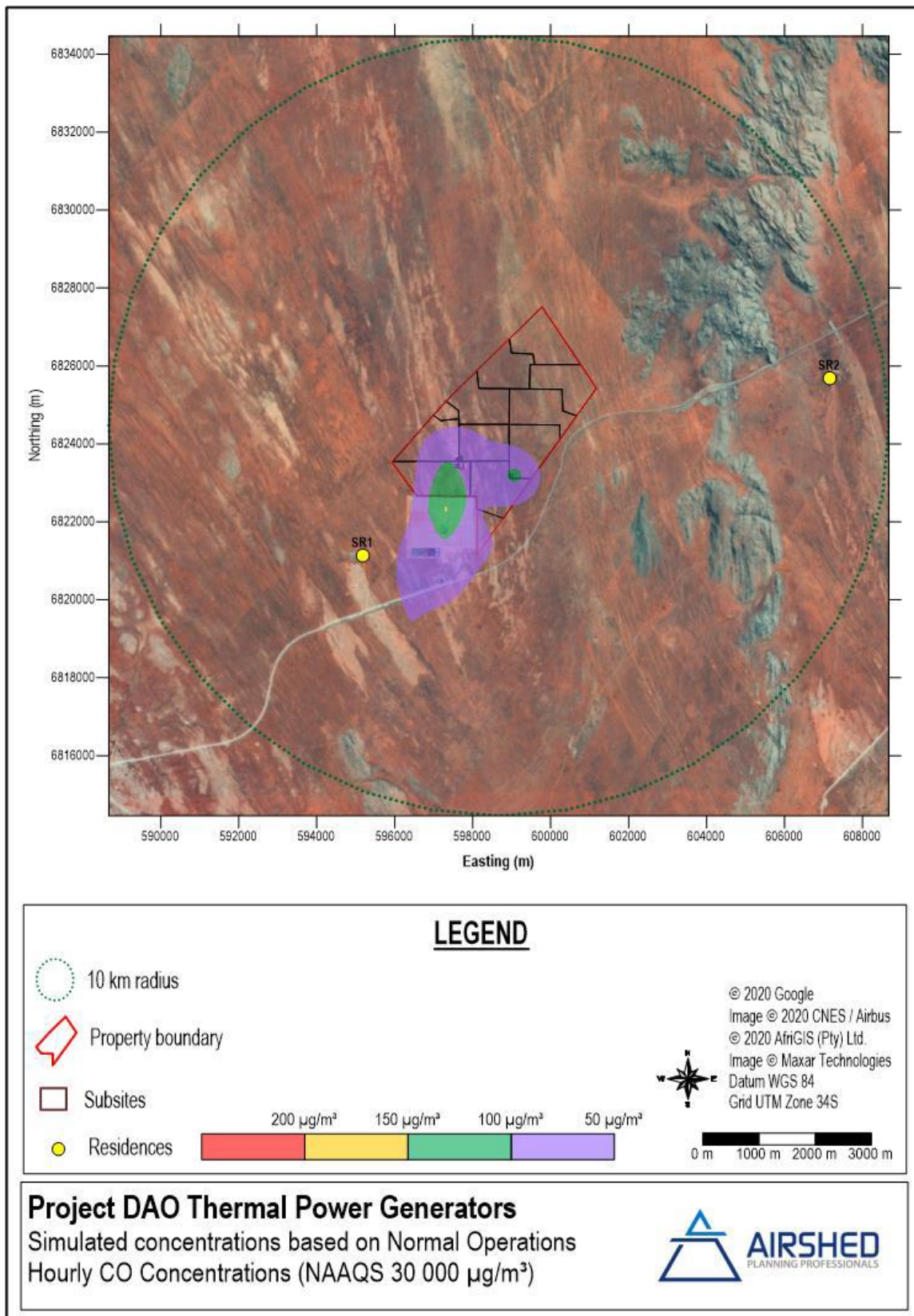

Figure 42: Simulated hourly average ambient CO concentrations

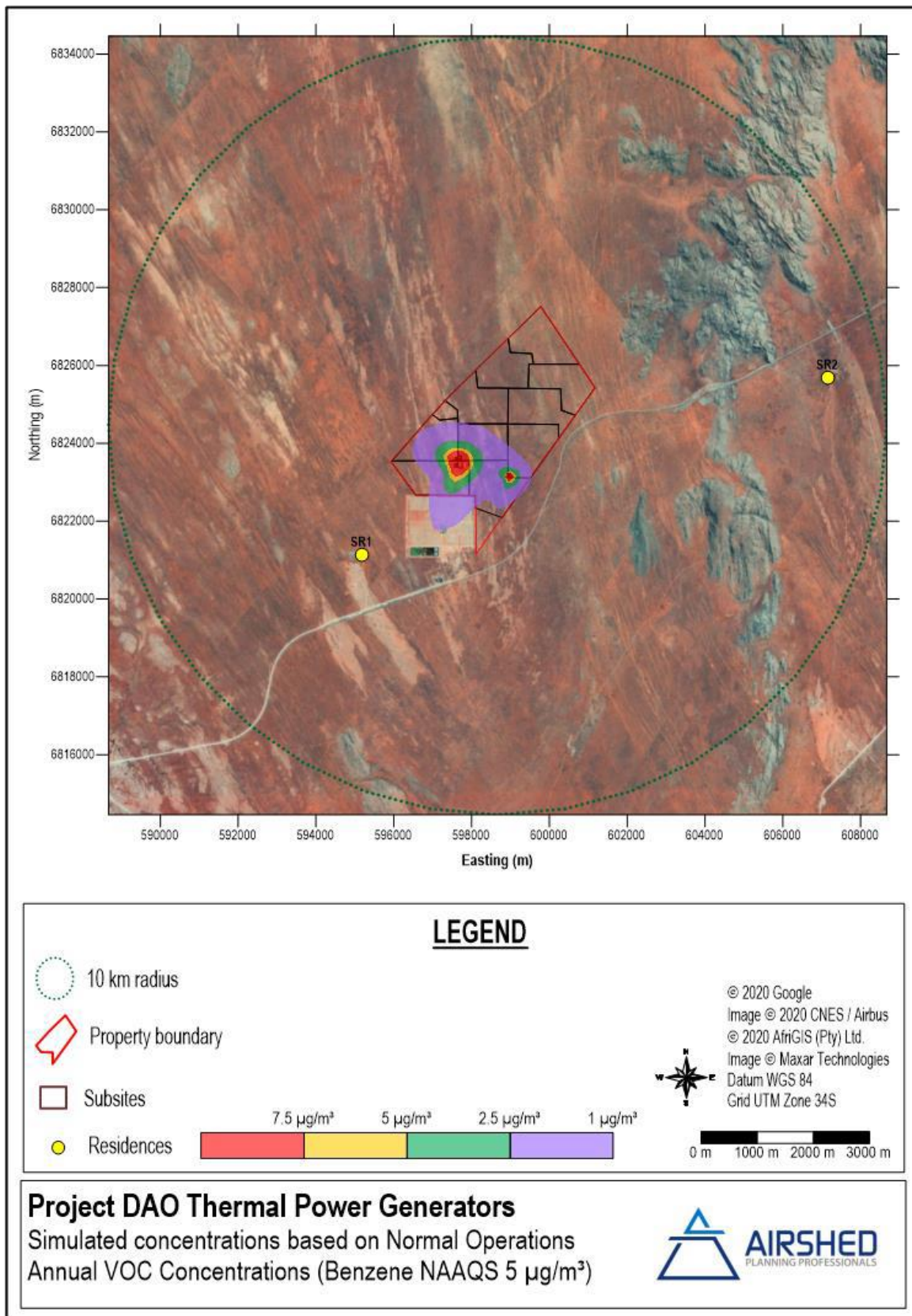

Figure 43: Simulated annual average ambient VOC concentrations

Analysis of Emissions Impact on the Environment

- The annual concentrations of SO₂ are lower than the critical level affecting cyanobacterial lichen across the domain, where the domain maximum annual average concentrations are less than 0.1µg/m³. Domain maximum annual NO₂ concentrations are less than 2µg/m³ and are therefore not likely to affect vegetation within the domain.
- The simulated annual concentrations of SO₂ associated with the project are very low (<0.1µg/m³ off-site) and are expected to have a negligible impact on animal health.
- The calculated (data not shown) maximum daily average concentration was lower than 265µg/m³, while the average simulated daily NO₂ concentration was less than 2µg/m³ the project is likely to have a low impact on animal health.
- Daily dustfall rates as a result of the project are likely to be below the NDCR for residential (or non-residential) during normal operations (Figure 44) – maximum dustfall rate <20mg/².day).
- Estimated dust fallout rates due to the project are low (<20 mg/m².day) (Figure 44). While dust fallout can have a negative effect on both plant growth and the economic value of crops, the impact is expected to be limited due to the nature of surrounding land use being predominantly small stock farming.

In summary, the operation of the generator sets will result in emissions of SO₂, CO, particulate matter, and VOC emissions. Ambient pollutant concentrations and nuisance dustfall rates will increase during the periods of operation. Off-site exceedances are not expected. This impact has a pre-mitigation rating of **moderate (SP = 30)** that is reduced to **low** significance (**SP = 21**) with the implantation of the following mitigation measures:

- Low sulfur fuel, with a maximum of 500ppm.
- Start-and-stop preventative maintenance operation of the generators is limited to day-time hours only, ideally between 10:00 and 14:00.
- As far as is practical, the reliability tests should be conducted when seasonal conditions allow the best pollutant dispersal (August to November).
- Generator maintenance and repair programme in accordance with the original equipment manufacturer recommendations.
- Mitigation measures for control vehicle entrainment dust emissions are recommended along the delivery route.
- Continue the use of the Complaints Register established during construction.
- Fence-line monitoring using passive samplers or low cost-sensors.

The operation of the generator sets will result in substantial emissions of NO_x. Ambient pollutant concentrations will increase during the periods of operation. Off-site exceedances are expected although compliance with NAAQS is likely under the operational philosophy. This impact has a pre-mitigation rating of **moderate (SP = 30)** that is reduced to **low** significance (**SP = 24**) with the implantation of the following mitigation measures:

- Start-and-stop preventative maintenance operation of the generators is limited to day-time hours only, ideally between 10:00 and 14:00.
- As far as is practical, the reliability tests should be conducted when seasonal conditions allow the best pollutant dispersal (August to November).
- Generator maintenance and repair programme in accordance with the original equipment manufacturer recommendations.
- Continue the use of the Complaints Register established during construction.
- Fence-line monitoring using passive samplers or low cost-sensors.
- Based on the operational philosophy additional NO_x mitigation measures would only need investigation if fence-line monitoring indicates regular and sustained exceedances of the NAAQS.

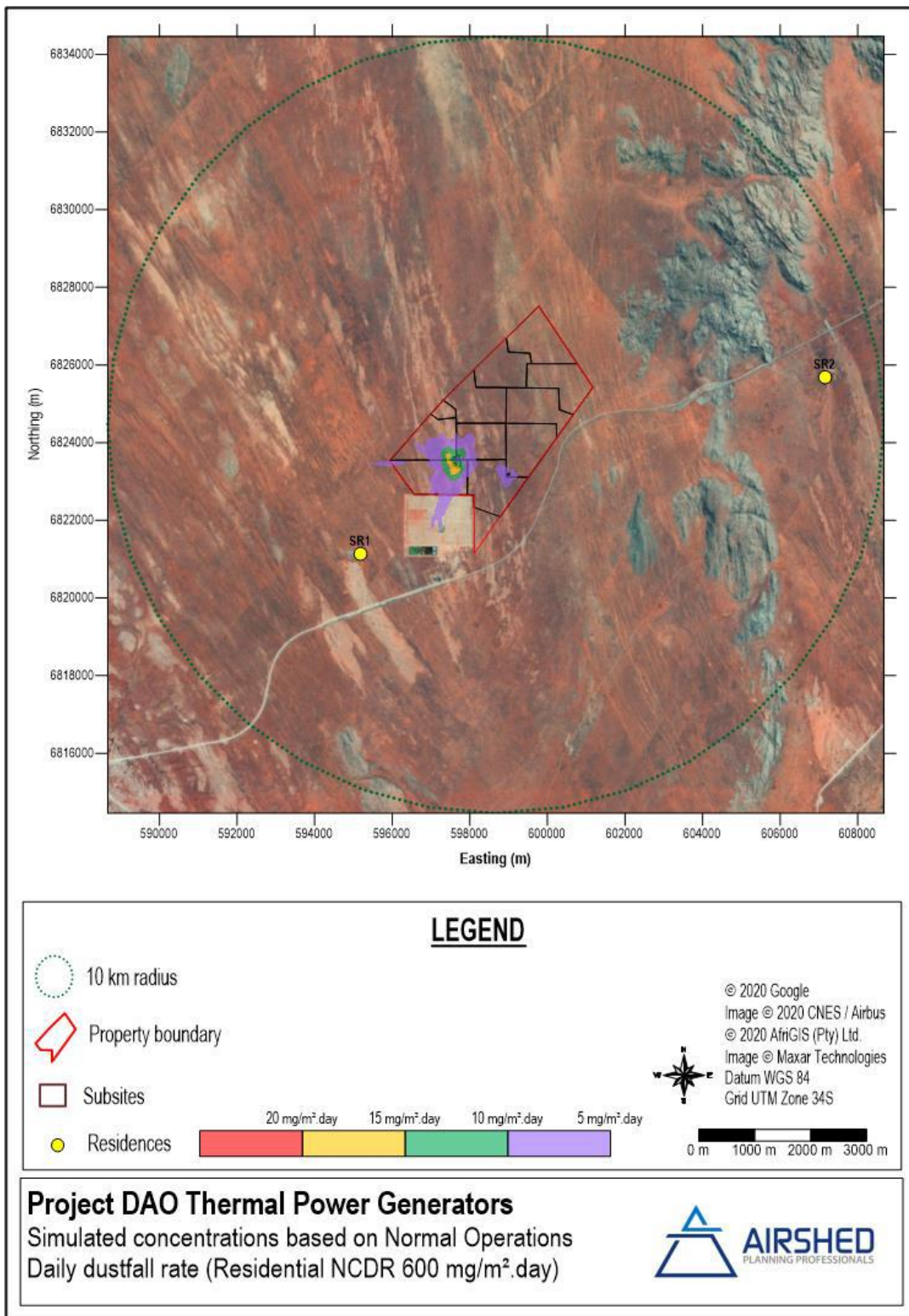

Figure 44: Simulated daily dustfall rates

7.3.8.3 Closure and Rehabilitation

The decommissioning phase of the generator sets will result in emission of particulate matter, and to a lesser extent, gaseous pollutants. Ambient pollutant concentrations and nuisance dustfall rates will increase during the decommissioning periods. Impact is likely to be localised near demolition activities. With mitigation, off-site exceedances are not expected.

The impact is rated as having a **low** impact (**SP = 15**) with and **low** impact (**SP = 12**) without mitigation. Refer to mitigation measure proposed during the construction phase.

7.3.8.4 Cumulative

During construction there is some risk that the construction activities could contribute to elevated particulate matter concentrations and nuisance dustfall rates off-site during high wind speed events. Cumulative impacts are likely to be limited in duration and frequency and of **low** significance with the implementation of mitigation measures mentioned above.

During operations cumulative effects are likely to be limited (with a **low** significance) since ambient air quality in the air is considered good and the mitigated impact of the generators is likely to be a localised impact during operations.

The cumulative impact of the proposed 49.5MW thermal power generation (ICE) facility was assessed by adding the off-site maximum simulated concentrations to the measured concentrations at the DFFE Karoo monitoring station (Table 42). The proposed facility is likely to make the largest impact on hourly NO₂ concentrations with potential exceedances of the NAAQ limit concentration. Based on Table 40, the number of exceedances is likely to be within the frequency allowed by the NAAQS.

Table 42: Estimated cumulative impact of the project and existing baseline air pollutant concentrations

Source Group	SO ₂ (µg/m ³)			NO ₂ (µg/m ³)		PM ₁₀ (µg/m ³)		PM _{2.5} (µg/m ³)	
	Hourly	Daily	Annual	1 hour	Annual	24 hour	Annual	24 hour	Annual
Baseline Karoo ^(a)	17.0	17.0	6.4	9.6	4.6	39.5	2.4	16.3	2.4
ACWA Project DAO ^(b)	18.7	6.8	0.016	442.0	1.2	5.5	0.013	5.5	0.013
<i>Cumulative</i>	35.8	23.8	6.4	451.6	5.8	45.0	2.4	21.8	2.4

Notes:

^(a) 2019 used as indicative year since data availability was acceptable and representative of a full year

^(b) Conservatively uses off-site maximum simulated concentration

7.3.9 Climate Change

7.3.9.1 Construction

- **Carbon Sequestration and Carbon Sink**

Accounting for the uptake of carbon by plants, soils and water is referred to as carbon sequestration and these sources are commonly referred to as carbon sinks. Quantifying the rate of carbon

sequestration is however not a trivial task requiring detailed information on the geographical location, climate (specifically temperature and humidity) and species dominance⁸².

Photosynthesis is the main sequestration process in forests and in soils. Carbon is absorbed as fixed carbon into the roots, trunk, branches and leaves, and during the shedding of leaves and limbs, but is emitted – although at a reduced percentage – from foliage and when biomass decays. Several factors also determine the amount of carbon absorbed by trees such as species, size and age. Mature trees, for example, will absorb more carbon than saplings⁸³.

There will be a carbon sink loss due to the vegetation removal for the expansion area. These are considered Scope 1 carbon emissions.

The regional vegetation types of the site were recently described as a transitional area between the savanna and Nama-Karoo biomes, including the Kalahari Karroid shrubland and *Gordonia* Duneveld ecological types. This vegetation type would be considered grassland in the National Greenhouse Gas Emission Inventory. The National Greenhouse Gas Emission Inventory assumes a grassland carbon stock of 5.32 tonne C/ ha. During construction, approximately 0.5ha will be denuded for the construction of each generator sets, a total of 3.6ha for all generators. Assuming all carbon eventually reports to the atmosphere as CO₂, it is therefore calculated that a total of 19.5 tonnes of CO₂ would be released as a result of clearing vegetation at the site.

- **Fuel Combustion**

GHG emissions from fuel during construction of the facility are also considered Scope 1 emissions. Emissions from these activities were not included in this assessment, however due to the relatively short construction period, they are not likely to make a significant contribution to the project's life-time total emissions.

- **Electricity use**

These emissions are related to purchased energy, heat or steam and can be calculated from the average South African emission factor published annually by Eskom in its integrated report. Electricity use on-site during the construction phase was not estimated but likely to be less than that used annually during the operational life-time of the facility.

7.3.9.2 Operations

For combustion processes, the emission factor is often calculated from a carbon mass balance, where the combustion of each unit mass of carbon in the fuel leads to an equivalent emission of 3.67 mass units of CO₂ (from 44/12, the ratio of molecular weight of CO₂ to that of carbon).

This report considers Scope 1 emissions, which are the emissions directly attributable to the project. Scope 2 emissions, which are the emissions associated with bought-in electricity over the lifetime of the project. Scope 3 emissions, which consider the “embedded” carbon in bought-in materials, are not considered here, in line with the guidelines provided by the International Finance Corporation⁸⁴.

⁸² Ravin, A., & Raine, T. 2007. *Best Practices for Including Carbon Sinks in Greenhouse Gas Inventories*. 16th Annual International Emissions Inventory Conference. Raleigh: United States Environmental Protection Agency. Retrieved from https://gaftp.epa.gov/Air_Quality_Data/nei/ei_conference/EI16/session3/ravin.pdf

⁸³

⁸⁴ IFC. 2012. *Performance Standard 3 Resource Efficiency and Pollution Prevention*. Retrieved from International Finance Corporation: https://www.ifc.org/wps/wcm/connect/25356f8049a78eeeb804faa8c6a8312a/PS3_English_2012.pdf?MOD=AJPE RE

▪ **Scope 1 Emissions**

The Carbon Tax Bill and its supporting technical documents provides default emission factors for Electricity and Heat Production process (specifically combustion of diesel) in kg CO₂/ unit energy content, where the density and calorific values of the fuel types are defined in the same document⁸⁵.

A summary of the operational GHG emissions, based on the fuel use per unit per hour at a 75% load (provided by the preferred equipment supplier), 56 units (all 5 ICE) operating over an annual operating period of 104 hours for diesel is provided in Table 43. The total CO₂ (equivalent) emissions from the diesel-fired engines will be approximately 3 263 tpa for diesel. The lifetime of the project is expected to be 22 years.

Table 43: Summary of Scope 1 estimated greenhouse gas emissions for the power station operation

Sources	Throughput	Units	Annual Emission (tonnes / year)			Annual Emission (tonnes / year)
			CO ₂	CH ₄	N ₂ O	CO ₂ -e (c)
<i>Diesel – reliability test (15 days)^(b)</i>						
Stationary Gas Combustion ^(a)	5 992	m ³	15 478	0.63	0.13	15 530
Total annual Scope 1 GHG emissions – diesel^(d)						
<i>Diesel – normal operation (2 hours per week = 104 hours per year)</i>						
Stationary Gas Combustion ^(a)	1 259	m ³	3 252	0.13	0.03	3 263
Total annual Scope 1 GHG emissions – diesel^(d)						
Notes:						
a) Emissions calculated using the DEA Technical Guideline TG-2016.1 (DEA, 2017). Emission Factors and Net Calorific Values as per Table D1. Default emission factors for stationary combustion of diesel. Fuel throughput based on 60 units combusting 201.75 litres per hour by each generator set.						
b) Conservatively assumes 15-day continuous operation of the generators during dispatchable hours (i.e. 16.5 hours daily).						
c) CO ₂ -e = equivalent CO ₂ emissions taking account of the global warming potential of CH ₄ and N ₂ O (as per DEA, 2017).						
d) Values rounded up.						

▪ **Scope 2 Emissions**

All on-site electricity needs (to power water treatment plant, offices, pumps, and other equipment) will be a parasitic load to the amount of electricity produced. This loss of production capacity has been factored into the total plant generating capacity calculations. Therefore, there will be no Scope 2 GHG emissions during normal operation of the project.

▪ **The Project's GHG Impact**

- **Impact on the Sector and on the National Inventory**

The annual CO₂-e emissions from the power station operations using diesel would, at maximum in the first year assuming one 15 day reliability test where the 56 generators operate continuously during dispatchable hours, contribute 0.004% to the South African “energy” sector total and

⁸⁵ Department of Environmental Affairs. 2017. DEA. (2017). Technical guidelines for monitoring, reporting, and verification of greenhouse gas emissions by industry: A companion to the South African national GHG emission reporting regulations. Pretoria: Department of Environmental Affairs (TG-2016.1).

represent a contribution of 0.004% to the National GHG inventory total (based on the published 2015 National GHG Inventory).

- ***Alignment with National Policy***

Most of the South African GHG policy is in early phases of implementation where GHG emissions have been reported to DFFE since 31 March 2018 and the Carbon Tax Bill came into effect on the 1 June 2019. The project will be required to align GHG reporting with national policy. An annual Carbon Tax environmental levy account will need to be submitted in July of each year after operations commence.

▪ ***Physical Risks of Climate Change on the Project's Operations***

- ***Temperature***

With the increase in temperature, including heat waves, there is the likelihood of an increase in discomfort, possibility of heat related illness (such as heat exhaustion, heat cramps, and heat stroke). Both these have the potential to negatively affect staff process performance and productivity.

From a process point of view, elevated ambient temperatures (up to 45°C) may slightly reduce the fuel requirements needed to meet the generating capacity required.

- ***Rainfall, Water Stress, and Extreme Events***

The rainfall decreases in autumn, winter and spring could result in constrained water supply outside of the summer months.

The impact of intense rainfall events on the generator sets cannot be ruled out, where the frequency of intense rainfall events could increase from the long-term baseline. These events could affect generative capacity during intense rainfall (unless fully protected from rain and wind); flooding affecting site access, safe operation of equipment and delivery of fuel; physical damage to infrastructure during high wind speed events associated with intense storms.

▪ ***Impact Assessment: Potential Effect of Climate Change on the Community***

- ***Temperature***

With the increase in temperature, including heat waves, there is the likelihood of an increase in discomfort and possibility of heat related illness (such as heat exhaustion, heat cramps, and heat stroke). There is also the possibility of increased evaporation which in conjunction with the decrease in rainfall can result in water shortage. This does not only negatively affect the community's water supply but can reduce the crop (vineyard) yields and affect livestock (sheep) resulting in compromised food security.

- ***Rainfall, Water Stress, and Extreme Events***

As discussed above the decrease in rainfall can result in the following effects:

- Reduced water supply of reduced water quality; and,
- A negative impact on food security.

The impact of intense rainfall events on the local communities cannot be ruled out, where the frequency of these event could increase from the long-term baseline. These events could affect road access within the area due to flooding; physical damage to public and private infrastructure through flooding and high wind speeds.

The impact is rated as having a **moderate** impact (**SP = 33**) with and without mitigation. Proposed mitigation measures include:

- Reduced fuel usage through minimal idle time of stationary diesel delivery and fuel-efficient vehicles.
- Local sources of diesel would reduce the Scope 3 emissions (compared with imported diesel).

7.3.9.3 Cumulative

Historical global GHG emissions will have an impact on the project and the communities in the !Kheis Local Municipality. The operation of the generators will therefore contribute to projected impacts at a local, national, and global scales (albeit at through a relatively small annual contribution). The impact of global climate change is likely to have a largely permanent impact on the global ecosystem with potential irreplaceable loss of resources.

Assuming that the hybrid facility replaces generative capacity from other fossil fuel sources, the facility could lower South Africa's GHG emissions from the Energy sector since the ICE plant provides only support to the PV arrays and BESS which provide renewable energy at a lower CO₂-e emission per unit electricity.

7.3.10 Heritage

7.3.10.1 Construction

Heritage impacts are categorised as:

- Direct or physical impacts, implying alteration or destruction of heritage features within the project boundaries;
- Indirect impacts, e.g. restriction of access or visual intrusion concerning the broader environment
- Cumulative impacts that are combinations of the above.

For the current study, as no sites, features or objects of cultural significance were identified, no mitigation measures are proposed. Should any heritage artefacts be exposed during excavation, work on the area where the artefacts were discovered, must cease immediately and the ECO must be notified as soon as possible. All discoveries must be reported immediately to a heritage practitioner so that an investigation and evaluation of the finds can be made. Acting upon advice from these specialists, the ECO will advise the necessary actions to be taken. Under no circumstances must any artefacts be removed, destroyed or interfered with by anyone on the site. Contractors and workers must be advised of the penalties associated with the unlawful removal of cultural, historical, archaeological or palaeontological artefacts, as set out in the National Heritage Resources Act (Act No. 25 of 1999), Section 51 (1).

7.3.10.2 Cumulative

The cumulative impact of the proposed project is assessed by adding impacts from this proposed development to existing and other proposed developments with similar impacts within a 60 km radius. The existing and proposed developments that were taken into consideration for cumulative impacts include a total of six other plants and are listed in Table 44. From the map 'South African Generation Projects' (Figure 45) below, it can be seen that the project is located in an area where little such development has taken place, with the implication that the cumulative impact would be very low.

The cultural heritage profile of the larger region is very limited. Most frequently found are stone artefacts, mostly dating to the Middle Stone Age. Sites containing such material are usually located along the margins of water features (pans, drainage lines), small hills and rocky outcrops. Such surface scatters or 'background

scatter' is usually viewed to be of limited significance⁸⁶. In addition to the Stone Age profile, there is also the colonial element. This manifests largely as individual farmsteads, in all its complexity, burial sites and infrastructure features such as roads, railways and powerlines, which occurs only in limited numbers. This again has the implication that the cumulative impact would be **very low**.

Table 44: Existing and planned alternative energy generation facilities in the larger region

Name	Nearest town	Technology	Capacity	Status
Bokpoort	Groblershoop	Concentrated Solar Thermal	50MW	Fully operational
Eskom	Upington	Concentrated Solar Thermal	100MW	Awaiting construction
Grootdrink	Upington	Solar PV	?	Proposed
Karoshhoek	Upington	Concentrated Solar Thermal	100MW	Awaiting construction
Tewa Isitha	Upington	Solar PV	?	Proposed
Upington	Upington	Solar PV	8.9MW	Fully operational

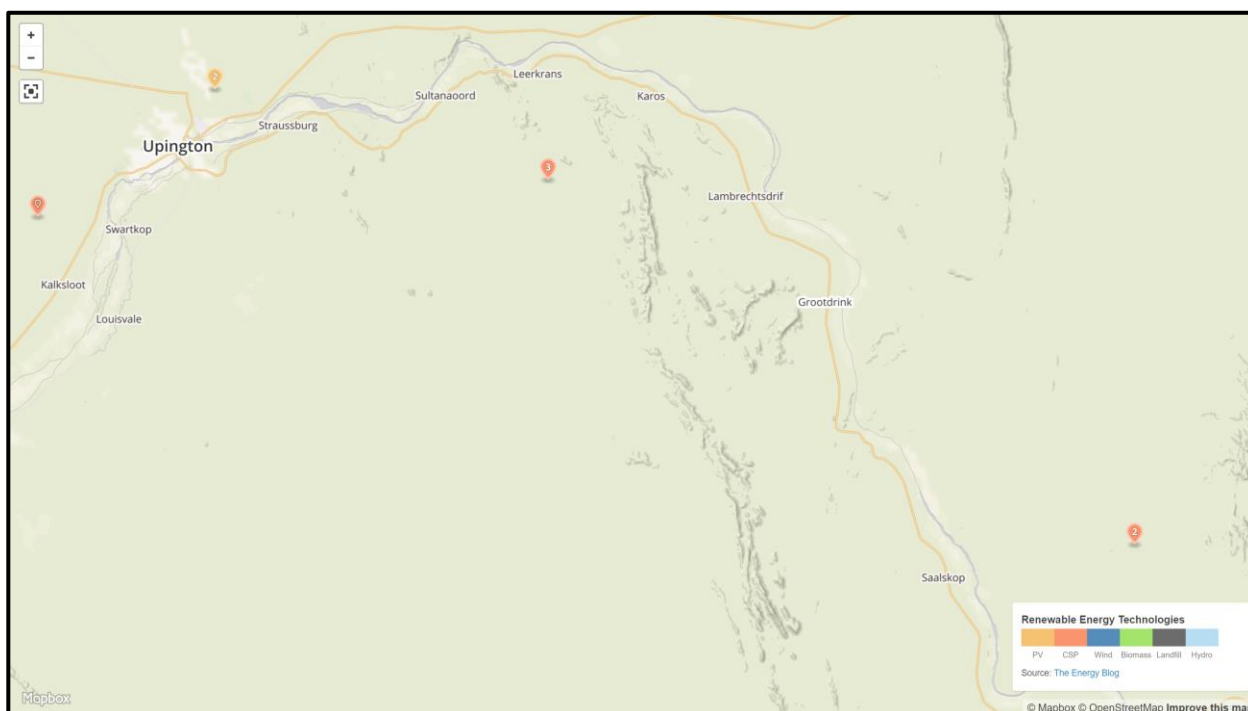

Figure 45: Map indicating the location of alternative energy generation facilities in the larger region

7.3.11 Palaeontology

7.3.11.1 Construction

The Precambrian metamorphic bedrocks underling the study area at depth are unfossiliferous while the overlying Late Cenozoic superficial sediments are generally fossil-poor. As a consequence of the paucity of irreplaceable, unique or rare fossil remains within the development footprint the overall impact significance

⁸⁶ Orton, J. 2016. *Prehistoric cultural landscapes in South Africa: a typology and discussion*. *South African Archaeological Bulletin* 71:119-129.

⁸⁷ <https://www.energy.org.za/map-south-african-generation-projects> - accessed 27/01/2020.

of the construction phase of the proposed PV plant as well as ICE developments is assessed as **low (SP = 16)** without mitigation, and **low (SP = 8)** after mitigation. The assessment applies to all the planned infrastructure within the project area.

Monitoring of all substantial bedrock excavations for fossil remains by ECO on an ongoing basis during construction phase, with reporting of any substantial new palaeontological finds (notably fossil vertebrate bones and teeth) to SAHRA for possible specialist mitigation.

7.3.12 Traffic⁸⁸

7.3.12.1 Construction

The envisioned impact of the PV facilities including ICE during the construction phase on the surrounding road network includes:

a) Deterioration of road network condition

The increase in traffic, and especially of vehicles carrying heavy loads will cause an increase in deterioration of the road network. The heavy vehicles are unlikely to have a significant impact on the National roads (N10, N14 and N8) as these roads have been built to high standard to carry heavy loads over a long design period. The surrounding gravel road network (Gariep and Transnet Service Roads) have not been designed to carry many repetitions of heavy loads as they cater specifically for local farmers and for the maintenance access to the Sishen-Saldanha railway line. There is a high possibility that the gravel roads will sustain damage during the construction period.

The significance of the impact is reduced from a **moderate impact (SP = 60)** before mitigation to a **low impact (SP = 24)** with the following mitigation:

- The Transnet Service Road must be re-gravelled (150 mm thick over width) before construction commences of the PV facilities. The prevention of dust, maintenance of the gravel road and re-gravelling of the road to be coordinated with Transnet. Once re-gravelled, the road should be regraded on a monthly basis to prevent the deterioration of the road condition.

b) Increase in dust

This impact is only applicable to the gravel roads. Dust is generated due to heavy vehicles and high speeds; therefore, the impact is more significant during the construction phase than during the operational phase. Farmers in the area are concerned about potential dust generated due to the increase in vehicles on the nearby roads. Transnet is also concerned regarding dust on their railway lines.

Dust impacts will be reduced from a **moderate (SP = 50)** to a **low (SP = 18)** significance by regularly (at least daily, depending on the wind intensity and direction as well as rain conditions) suppressing the dust especially in the road section adjacent to the Bokpoort I plant and proposed PV facilities.

c) Increase in traffic volumes impacting on LOS

The increase of traffic during the peak hour of 90 vehicles for simultaneous construction i.e. a maximum of 3 PV facilities being constructed at one time, will have a significant impact on the LOS of the roads or intersections during the construction period, with the LOS being maintained at a LOS D for the southern approach (Gariep Road) at the Gariep/ Transnet Service Road intersection. The entire intersection, however, will maintain a LOS A for the simultaneous construction of the PV facilities.

⁸⁸ Applicable to the development of the PV plant as well as ICE.

The intersection was analysed for different scenarios for the construction period with the worst case being the simultaneous construction of the PV facilities. Regarding the worst-case scenario, the southern approach of the intersection will operate at a LOS E for the duration of the construction period due to high volume of vehicles as well as the dust generated.

The impact significance before mitigation is **moderate (SP = 60)** and of a **low significance (SP = 24)** with mitigation, provided the following measures are implemented:

- The delivery of materials and equipment by trucks can be phased through the day to reduce the impact the trucks have on traffic congestion and dust generation. The delivery of materials/equipment by abnormal vehicles, must be scheduled during off-peak periods in order to have the least impact on traffic conditions.
- As far as possible, construction traffic should follow the route via Upington and Gariep Road northbound and avoid using the northern section of the Gariep Road between the N14 and the Transnet Service Road.
- On-site accommodation may be provided, and transport arranged for the labourers on site, to reduce the traffic volumes using the gravel roads (Gariep Road and Transnet Service Road).

d) **Deterioration of road safety conditions**

Road safety deterioration is due to dust and speeding, causing drivers to lose control on the gravel roads. As a result of the upgrade of the Gariep Road for the construction of Bokpoort I plant, drivers are able to reach high speeds exceeding the recommended 80 km/ hr speed limit. High speed accidents and fatalities has occurred, including some of the construction staff.

The speed limit must be managed by the local Traffic Police on the Gariep Road, this will increase the road safety and minimize the dust impact on the farms along this section of the road and will reduce the significance of the impact from **moderate (SP = 32)** to **low (SP = 18)**.

7.3.12.2 **Operations**

The operational phase will not generate heavy vehicle volumes when compared to the construction phase and the impact will be of a **low significance (SP = 16)** before and after mitigation. It should be reiterated that the ICE will only be operated when the solar resources are not available in extreme weather conditions. The ICE will not have long periods of operating time, hence the load factors of the ICE shall be low. The delivery of diesel will be by road tanker with current capacity of 32T - 45T per load, current first fill to site storage is expected with monthly top-up fills planned as required. Fuel to be transferred on site through a purpose build fuel offloading facility and stored in on-site storage tanks. The fuel storage system will be able to handle fuel for at least three consecutive days of full operation.

7.3.12.3 **Closure and Rehabilitation**

The traffic activities will be similar to those of the construction phase, but by the time of closure, it is highly likely that the traffic will have an impact of **moderate (SP = 40)** significance, which can be mitigated to one of **low (SP = 16)** significance by implementing the following recommended mitigation measures:

- Using only vehicles that are in good working condition;
- Ensuring that loaded vehicles are not too heavy for the road surfaces; and
- Appropriate speed limits are enforced by the local Traffic Police.

7.3.13 Visual

7.3.13.1 Analysis of Degree of Visual Intrusion at Receptor Locations

Distance banding from the proposed facility footprint has been used to determine the zone of likely visual exposure to the facilities into which the respective receptor locations would fall. Increasing distance from the proposed facility footprint has been used to give an indication of the likely visibility or potential degree of visual exposure to the solar plant developments from different parts of the study area. The following zones (distance bandings) have been utilised:

- <2km – zone of high potential visual exposure
- 2km – 5km – zone of moderate potential visual exposure
- 5km – 10km – zone of low potential visual exposure
- >10km – zone of marginal/ negligible visual exposure

It is very important to note that all but one of the (sensitive) receptor locations located within a distance of 10km of the proposed development fall into the zone of low potential visual exposure. The Bokpoort Farmstead is the only receptor location that is situated within the zone of moderate to high visual exposure. This receptor location is located within the viewshed of the development (Figure 46 and Figure 47); it is located on an isolated hillside (Photograph 5) with an aspect that faces in a northwards arc towards the development site. The raised position of the farmstead in relation to the surrounding plains entails that it is exposed to a clear view of much of the terrain (Photograph 5).

The receptor location will thus be subject to a high degree of visual exposure and thus a high level of visual intrusion. The visual intrusion factor associated with the new development would however be ameliorated by a number of factors; firstly, the new development would be viewed in the context of existing views of the Bokpoort 1 CSP Plant. As the proposed PV plants including ICE would be located directly adjacent to the existing solar power plant, these would be viewed as an extension of the existing solar plant in the context of a view of the landscape that has already been transformed from a completely natural context. In addition, the vegetation (large mature trees) located around the farmstead would be effective in screening the receptor from views to the surrounding areas.

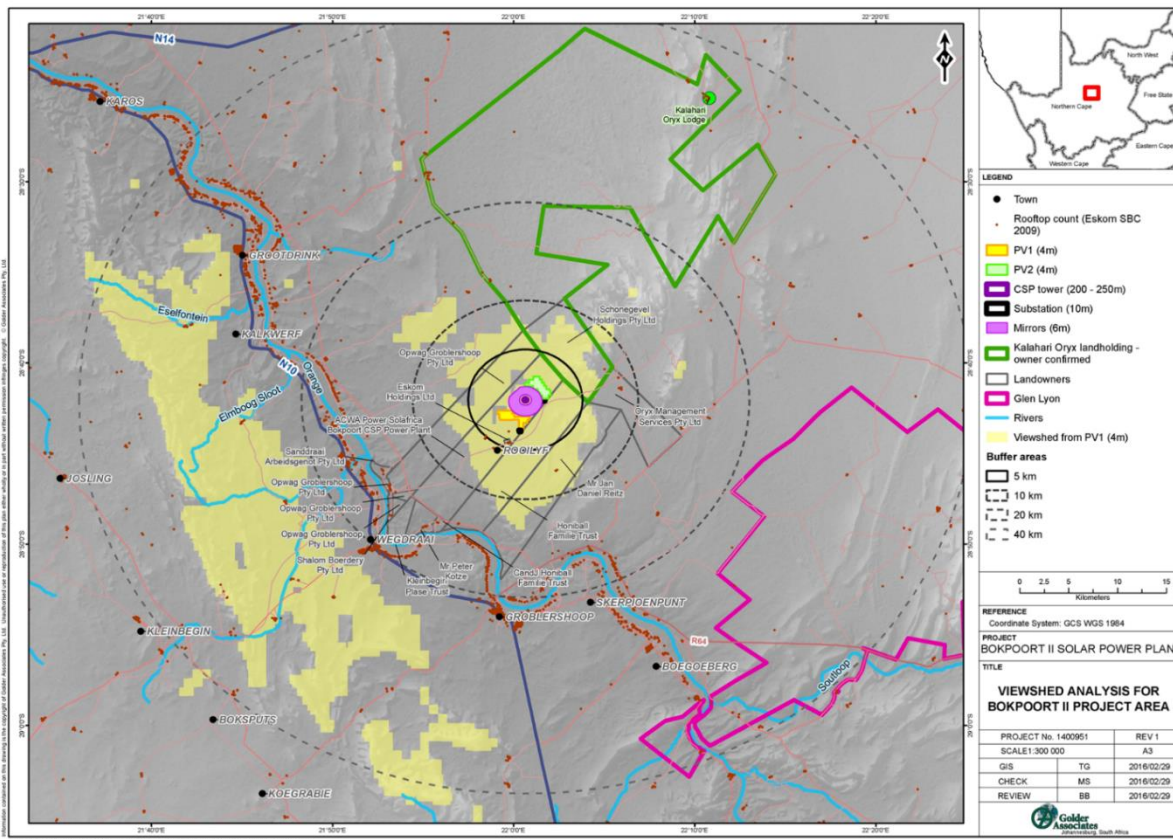

Figure 46: Viewshed analysis undertaken as part of the original Visual Assessment for the Ndebele PV plant representative of the southern part of the development site

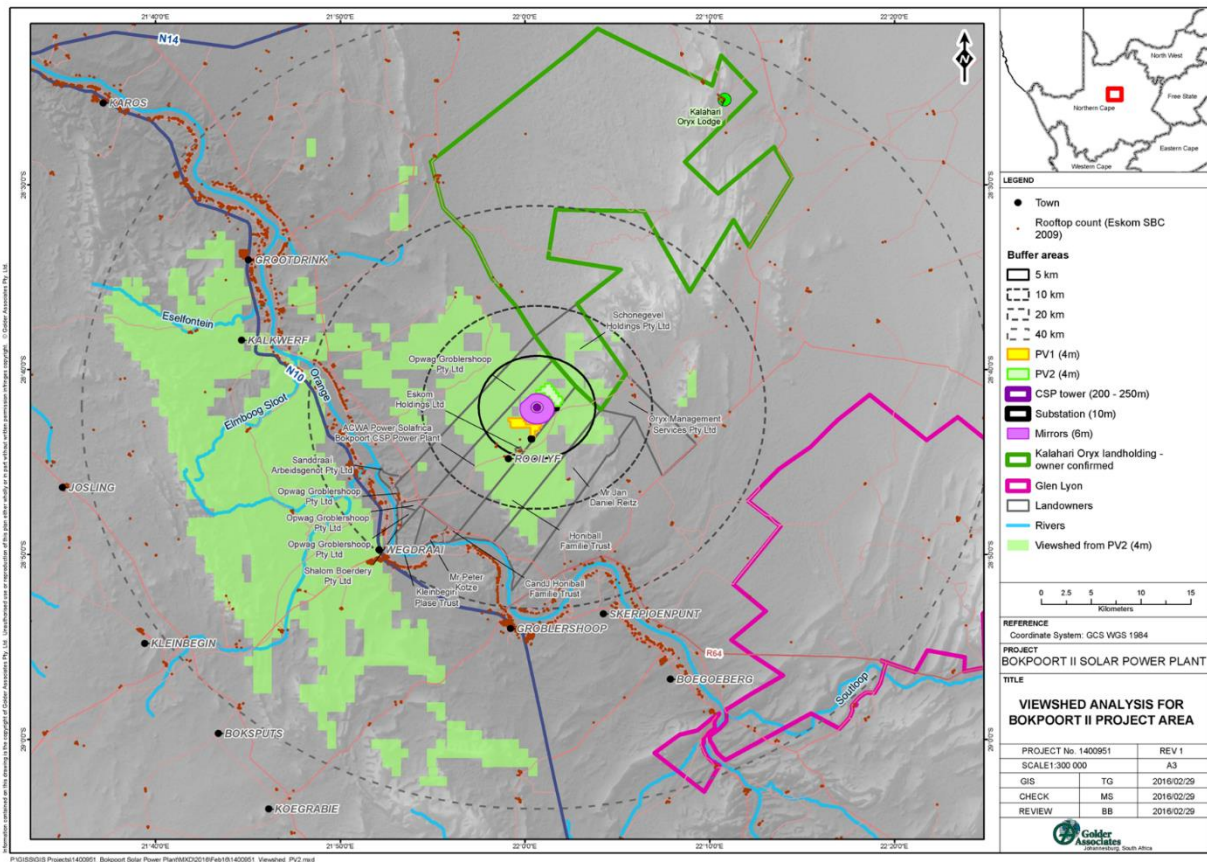

Figure 47: Viewshed analysis undertaken as part of the original Visual Assessment for the Zulu PV plant representative of the northern part of the development site



Photograph 5: The Bokpoort farmstead viewed from the Sanddraai property to the west. Note the elevated position of the farmstead in relation to the surrounding terrain

Of the six other sensitive receptor locations located within a distance of 10km of the development site, none are located within the viewshed of either the northern or southern part of the development (Figure 46 and Figure 47), thus meaning that none of these 6 receptor locations will be exposed to any views of the proposed development. Parts of the 5 – 10km radial area around the proposed development are located within the viewsheds of the development, in particular the viewshed of the northern part of the development which covers a greater area as the northern part of the development is located on higher-lying ground than the southern part of the development footprint. However significant parts of the radial area fall outside of the viewshed of the proposed development (Figure 46 and Figure 47). This is largely due to the presence of hilly/ mountainous terrain located within the north-eastern and eastern parts of the 10km radial area. This higher-lying terrain screens much of the 10km radial area in which the receptors are located, blocking views towards the site footprint.

Beyond the 10km radial area the visual exposure factor associated with the proposed plant would be minimal and twinned with the absence of visibility of the plant in large areas where receptor locations are clustered, in particular along the Orange River corridor would result in a negligible visual impact. Most of the Orange River corridor lies outside of the viewshed of the development, and accordingly will not be visually affected by the proposed development.

When non-static receptor locations are considered, the visual intrusion factor of the development will be very low to negligible. The only public access located in the 10km radial area is a short section of the Gariep Road. This, and the other stretches of the road are located outside of the viewsheds of the development (Figure 46 and Figure 47), and thus will be exposed to no visual exposure to the proposed development.



Photograph 6: View in the direction of the development site from the raised portion of the Gariep Road that crosses the Transnet Railway; neither the Bokpoort 1 Solar Plant or the proposed development area would be visible

Overall, the degree of visual intrusion associated with the proposed development components is likely to be low at worst, with the distance between most of the receptor locations and the development site being the greatest contributing factor, twinned with the non-visibility of the development in large parts of the study area. The proposed development is thus very unlikely to result in the creation of a visual impact, or perceptions of visual impact by people inhabiting the sensitive receptor locations in the 10km radial area or

moving transiently within the area. Twinned with the presence of the Bokpoort 1 CSP Plant and the Eskom Garona Substation the proposed solar development will add to the presence of large-scale power generation infrastructure in the study area, but which due to its remote location and the low density of human settlement will not generate any degree of visual exposure beyond that which is very low, thus being unlikely to generate any visual impacts.

7.3.13.2 Construction

The Gariiep Road is an unsurfaced (untarred) road and accordingly dust is typically generated by vehicles travelling along it. The road surface is comprised of material that originates from calcrete and thus fine white dust is mobilised by vehicles moving along the road. Dust generation on the road, however, has in the past proved to be a contentious issue in the context of the construction of the Bokpoort 1 Plant and the large number of construction vehicles that travelled along the road and which generated large volumes of dust. The objections from local farmers and landowners were centred on the adverse impacts of the depositing of large volumes of fine dust on the vegetation surrounding the road that allegedly greatly reduced the palatability of the vegetation and the overall grazing capacity of the veld. The transport of components of the proposed PV plant and ICE developments by road would result in a highly significant daily increase in the volume of heavy vehicle traffic along the road, which would last for much of the duration of the construction period. In this context the generation of dust plumes by a large increased volume of heavy vehicle traffic may be perceived as a negative visual intrusion in conjunction with negative perceptions regarding dust-related grazing impacts, as well as road safety concerns.

A different set of receptors to those potentially affected by the development footprint would potentially be exposed to the dust plumes generated by construction traffic along the Gariiep Road. If construction traffic approached the development site from the south-east – i.e. from the N8 – a number of farmsteads, including three farmsteads located close to the road, and a greater number along the opposite side of the Orange River – would be exposed to the regular dust plumes generated by construction vehicles. Though not necessarily significant as an impact on its own, the visual intrusion of the dust plumes could be perceived to have significant nuisance value in combination with negative perceptions of adverse effects on vegetation and concerns relating to road safety.

Dust plumes generated along the Transnet Service Road could have a similar visual effect, but apart from a short stretch of the road located close to the Gariiep Road. This road is remote from any areas of public access and dust plume-related impacts will be mitigated by the distance factor in a similar manner to dust plumes generated on the development site.

Without mitigation the impact is rated as **moderate** significance (**SP = 44**) and by implementing dust suppression measures, especially on road stretches located within 500 m of households/ farmsteads located close to the access route and enforcing speed limits, the significance of the impact is reduced to **low (SP = 16)**.

The construction site would not be visible to the vast majority of the receptor locations in the study area, and dust plumes generated at the construction site would be unlikely to cause any visual impact for the majority of the study area. The impact is **low (SP = 18)** before mitigation and **low (SP = 16)**, with the following key mitigation measures:

- Clearing of vegetation must be undertaken in a phased manner, so as to prevent the large-scale exposure of soils and substrate that could result in a large visual contrast compared to the surrounding vegetation and the mobilisation of unconsolidated substrate by wind.
- Dust suppression measures must be implemented on the construction site.
- Bulk earthworks must not occur on (forecast) very windy days.

7.3.13.3 Operations

The development would not be visible to the vast majority of the receptor locations in the study area, and thus would not cause any visual impact for the majority of the study area, however it is recommended that all cleared areas during the construction phase that will not form part of the plant footprint, including powerline and pipeline servitudes should be rehabilitated and replanted with grass or low shrubs with non-invasive root systems, in order to avoid the creation of areas devoid of vegetation that may be visible from receptor locations. The significance of the impact is **low** both before and after mitigation (**SP = 24**).

Lighting impacts – most parts of the study area are highly rural in nature with a very low density of human settlement. Accordingly, the night-time environment within the wider area is thus characterised by few sources of artificial lighting. Where these occur, these are highly localised. The location of the viewer is important as viewers located in low-lying terrain settings (such as in the Orange River valley) would not be able to view the lights in the surrounding area. However, viewers in higher lying settings, such as certain of the receptor locations on higher-lying ground closer to the N10 west of the Orange River valley would be able to view a greater area, and thus see the light sources in this wider area (including the ground to the east of the river).

The primary sources of lighting are floodlights that illuminate on a permanent (nightly) basis in a number of the small settlements located along the N10 including Wegdraai, Saalskop and Grootdrink to the north as well as in certain parts of Groblershoop and the settlement of Boegoeberg to the south. A number of these very tall floodlights provide general illumination for these respective settlements in the absence of (lower) street lighting. The height of these lights makes them highly visible in an otherwise dark night-time context. When viewed from a high point the effect is of 'islands of light' in an otherwise very dark, unlit night-time context.

Lighting impacts are rated as **low (SP = 24)** without mitigation and **low (SP = 20)** with the mitigation measures listed below:

- Lighting of the plant at night should be limited to security lighting (where this is necessary), and emergency operational lighting must only be lit when required.
- The height of any lights should be limited; more lights of lower height should be installed rather than fewer floodlights that would be visible from a wider area.
- All lighting as far as possible (and according to international best-practices) be downward, and inward facing (towards the plant), to avoid light spill into surrounding areas.

7.3.13.4 Closure and Rehabilitation

The generation of dust plumes from closure and rehabilitation at the plant footprint as well as traffic from decommissioning activities are the same as for the construction phase. The impact is **low (SP = 18)** before mitigation and **low (SP = 16)** with the implementation of mitigation measures.

7.3.13.5 Cumulative

The proposed development will be located immediately adjacent to the Bokpoort I plant, so when viewed from the surrounds it will form part of a visual environment that is already transformed from a natural context. The proposed development will add to the transformation of the landscape in the local area, thus increasing the cumulative visual effect on the landscape. However, the remoteness of the location lowers the overall cumulative visual impact in a wider study area context.

The proposed development will be located immediately adjacent to the Bokpoort I plant and lighting at the new plant would increase the number of lighting sources able to be viewed from this area. Permanent lighting at the new plant would thus increase the number of light sources, albeit in a cluster rather than

adding diffuse lighting sources to the landscape, further altering the overall dark night-time environment to a more lit one.

7.3.14 Noise

7.3.14.1 Construction

The main activities during construction of the facility are summarised as follows:

- Site preparation, demolition and earthworks;
- Generator enclosure construction;
- Storage and handling infrastructure and utilities construction; and
- Delivery, installation and commissioning of plant machinery.

The assessment has assumed equipment will be operating at maximum capacity. The main identified noise intensive activities and equipment to be used include piling operations, hydraulic excavators, compactors, cranes, site generators, grinders, air compressors, jack hammers, and construction vehicles including articulated dump trucks, concrete premix trucks, and tractor loader backhoes.

Typical construction site noise without obstacles emits approximately 112dBA continuous sound power from activities such as steel grinding/ cutting and hammering, piling, earthmoving and construction vehicles. The maximum continuous time integrated sound pressure levels expected at the noise sensitive site due to the site emissions is summarized in Table 45 and a noise contour map is presented in Figure 48. The estimated maximum continuous noise levels due to construction are not expected to increase the ambient noise levels in the general surrounding area. The construction activities will be audible up to 500m from site and presents a negligible impact to Point B (Bokpoort Farmstead) during day and night-time hours.

Table 45: Predicted unmitigated construction noise level and excess ambient noise levels

Receiver	Predicted Construction Noise Levels LReq (dBA)	Predicted Daytime Excess Ambient Noise Levels ($\Delta L_{Req, d}$) (dBA)	Predicted Night-time Excess Ambient Noise Levels ($\Delta L_{Req, n}$) (dBA)
Point B (Residential)	25	0	0

The continuous typical construction site noise will not exceed the existing baseline noise levels. However, construction activities may still be audible during some periods of the night-time period as the baseline noise levels indicate the noise levels fall below 27dBA. This will not be considered a noise disturbance as the predicted construction noise level will not exceed 7dB above the baseline noise levels as defined in the Environmental Conservation Act, 1989 (Act No. 73 of 1989). However, the noise level exceedance from the predicted construction noise may cause noise nuisance claims during quiet night-time periods.

The construction phase is temporary and typically completed within two years.

The noise impact during the construction phase is assessed as being of **low (SP = 12)** significance before mitigation. The following mitigation measures are recommended to reduce the impact to one of **lower (SP = 5)** significance:

- All construction vehicles and equipment must be well maintained and kept in good condition.
- Construction staff working in areas where the 8-hour ambient noise levels exceed 85dBA must be provided with ear protection equipment.
- Particularly noisy operations must be scheduled appropriately and conducted after notifying sensitive receptors.

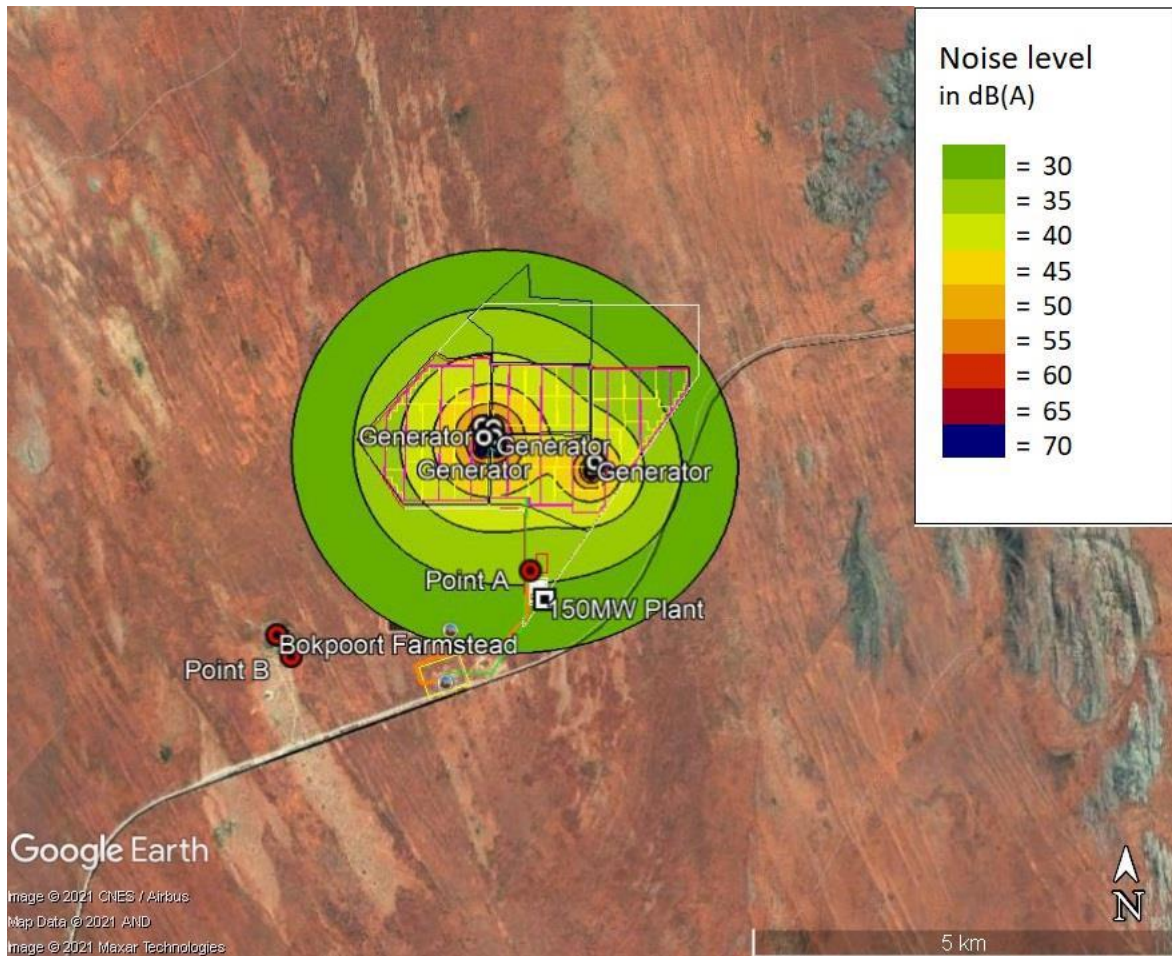

Figure 48: Predicted noise contour map for the construction phase

7.3.14.2 Operations

The following main noise generating activities were considered for a modelled investigated scenario(s):

- Generator engine noise;
- Generator exhaust noise; and
- Noise from the cooling fans.

The generator noise sources were modelled with the exclusions of a generator hall building (with attenuators) and exhaust silencers.

Simulated noise levels of the proposed project's operational phase are illustrated in Figure 49 in relation to sensitive receptors. Table 46 shows the potential noise levels that may be experienced at the closest noise sensitive site in conjunction with baseline noise levels.

Table 46: Simulation of the existing noise levels from the proposed generators

Site	Predicted Noise level at Closest Noise Sensitive Receptor dBA	Measured Baseline Noise Levels (Day / Night) dBA	District Rating Level (SANS10103:2008) Day / Night
Point B (Residential)	39	45.0 / 39.3	Rural Districts (45 dBA / 35 dBA)
Proposed Site	53	41.5 / 39.3b	Industrial District (70 dBA / 70 dBA)

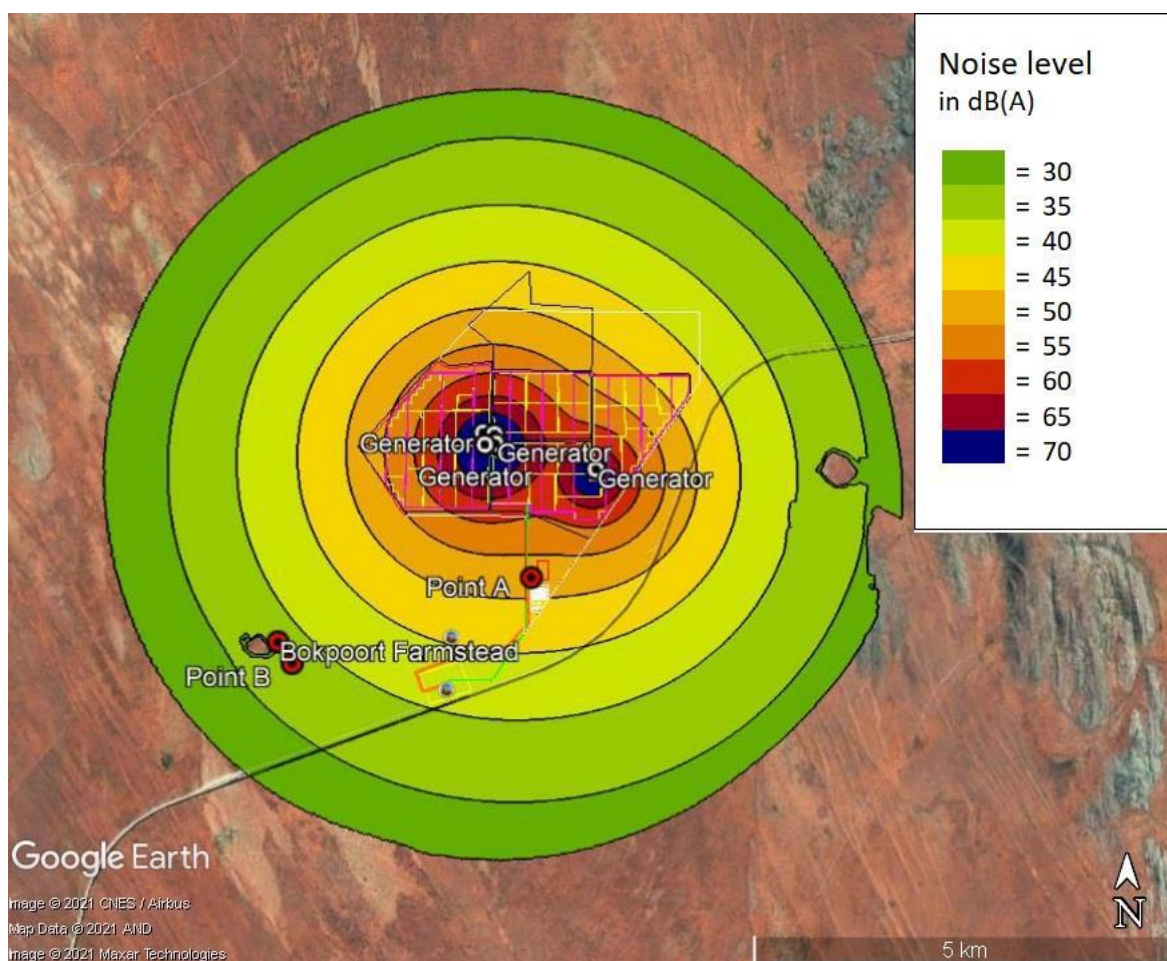

Figure 49: Predicted noise contour map for the operational phase

The proposed operational noise levels do not exceed the existing baseline noise levels by 7dB during day or night-time and thus does not constitute a noise disturbance. However, the generator noise will be audible during some periods of the day-time and night-time periods as the measured baseline noise levels vary between 20 and 40dBA which will cause noise nuisance complaints. If noise mitigation is implemented, noise nuisance complaints will be reduced significantly during the day-time and night-time periods.

In order to reduce the risk of noise nuisance claims at the noise sensitive receptor and to meet the industrial district (60dBA night-time), a 30dBA reduction will be required from each generator plant. This will also

reduce the noise-controlled areas (areas where hearing protection is required) within the existing and proposed solar plant.

Low frequency airborne noise which can be caused by gas generator exhaust systems can cause damaging vibration in light-weight buildings (both on site and at the noise sensitive receptor) will also need to be reduced when the noise mitigation is implemented.

The following noise mitigation measures must be implemented to each 9.9MW generator plant:

- A generator enclosure must be installed (Engine Hall Building) with a façade (including roof) that meets an airborne sound insulation (DnT, w) of 30dB.
- Appropriate inlet and outlet attenuators must be installed in the façade to meet the façade acoustic requirements of (DnT, w) of 30dB.
- It is assumed that extract fans will be fitted either on the side of the façade or on the roof. Extract fans are to be fitted with appropriate 2D circular pod attenuators.
- The exhaust systems must be designed to ensure that low frequency harmonics are not encouraged. The exhaust silencer/ s must make use of one or more 35dB exhaust silencer/ s.
- Noise barriers should be used where cooling fans are located.
- Noise monitoring will be required annually around the site boundary as well as the identified noise sensitive receptor. The measured noise levels must be documented and must include the following descriptors: Noise Monitoring will be required biannually around the site boundary as well as the identified noise sensitive receptor, in accordance to SANS 10103:2008. The measured noise levels must be documented and must include the following descriptors and performed in 1/3 octave bands: dBA, dBC, dBZ, LA90. Noise Measurements at noise sensitive sites must be performed for a full 24-hour period. Site and boundary measurements can be performed for shorter period as long as they are representative of the soundscape.

In addition to these mitigation requirements, it is recommended that a professional engineer who is qualified in acoustics with more than 15 years of experience, is employed to review, model the predicted noise of the final generator plant design and provide additional detailed acoustic design (where necessary) to ensure the five (two new and three previously authorised) generator plants do not negatively affect the noise sensitive receptor as well as the current and proposed infrastructure on the site.

With the implementation of the above mitigation measures the noise impact is assessed as of **moderate (SP = 40)** significance before mitigation can be reduced to a **low (SP = 18)** significance.

7.3.14.3 Closure and Rehabilitation

The noise impact is rated as **low (SP = 12)** before mitigation and **low (SP = 5)** with mitigation. Refer to the mitigation measures proposed during the construction phase.

7.3.14.4 Cumulative

Apart from the proposed 9.9MW Generator Plant, there is a proposed 150MW Generator Plant at the Bokpoort CSP site. As for other projects within a 30km radius, several Solar PV and Solar CSP plants are proposed, however the noise levels from these projects are not expected to increase the ambient noise levels in the surrounding areas of the Bokpoort CSP site. Thus, the only expected significant noise sources in the area surrounding the Bokpoort CSP site is the proposed 150MW Generator Plant and the 9.9MW Generator Plant located on the Bokpoort CSP Site.

Simulated noise levels of the proposed project's operational phase with the proposed 150MW ICE near the Bokpoort CSP site, illustrated in Figure 50 in relation to sensitive receptors. Table 47 shows the potential

noise levels that may be experienced at the closest noise sensitive site in conjunction with baseline noise levels.

Table 47: Simulation of noise levels from the proposed ICE

Site	Predicted Noise level at Closest Noise Sensitive Receptor dBA	Measured Baseline Noise Levels (Day / Night) dBA	District Rating Level (SANS10103:2008) Day / Night
Point B (Residential)	39.5	45.0 / 39.3	Rural Districts (45 dBA / 35 dBA)
Proposed Site	64	41.5 / 39.3	Industrial District (70 dBA / 70 dBA)

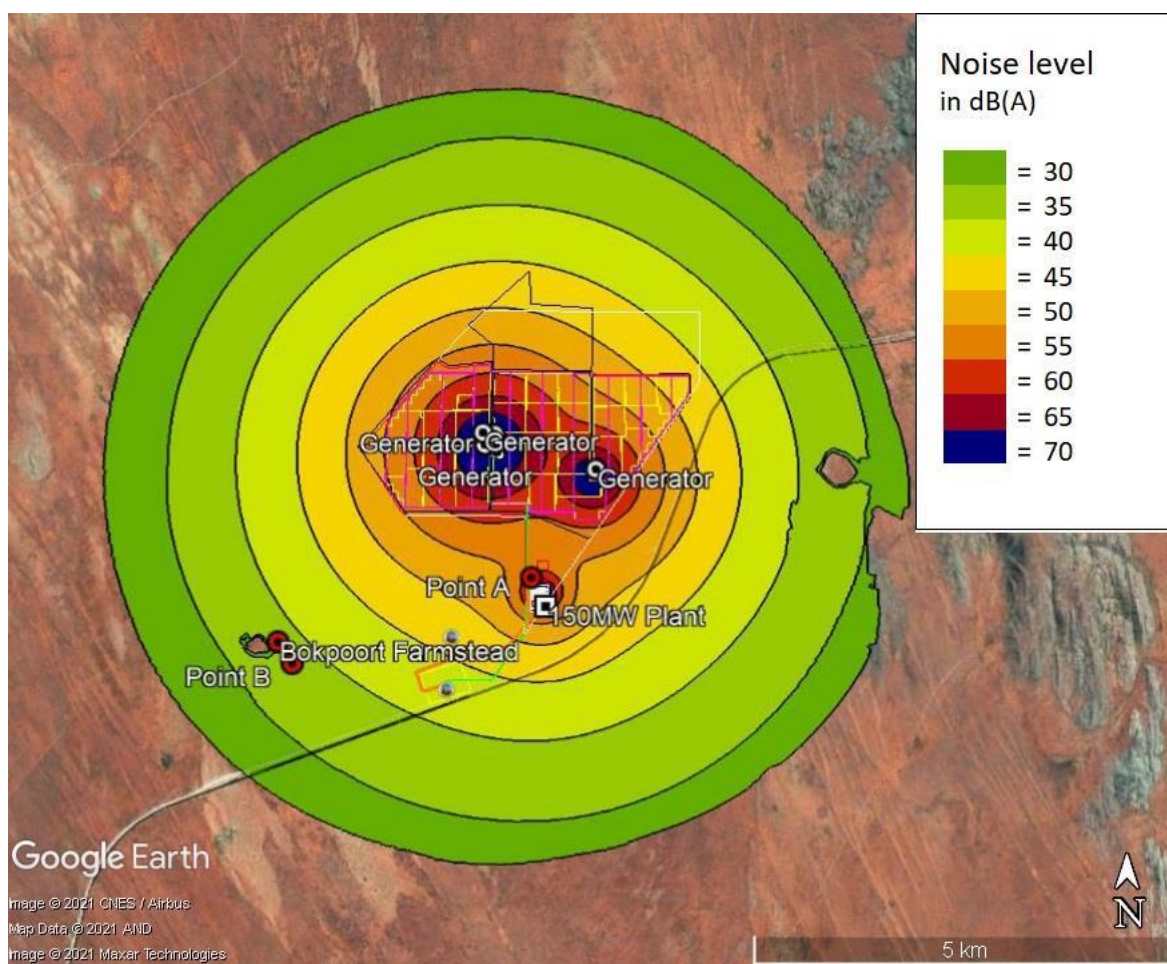

Figure 50: Predicted noise contour map of the cumulative operational phase of both proposed projects

The proposed cumulative operational noise levels at do not exceed the existing baseline noise levels by 7dB during day or night-time and thus does not constitute a noise disturbance (**low to medium** significance). However, the generator noise will be audible during some periods of the daytime and night-time periods as the measured baseline noise levels vary between 20 and 40dBA which will cause noise nuisance

complaints. If noise mitigation is implemented, noise nuisance complaints will be reduced significantly during the daytime and night-time periods.

7.3.15 Socio-economic⁸⁹

7.3.15.1 Construction

- Employment opportunities – construction of the PV plants including ICE will take about 12 – 18 months and provide about 100 to 250 employment opportunities, which has been assessed as a positive **moderate** impact (**SP = +30**) without mitigation and a positive **moderate** impact (**SP = +40**).
- Population influx – as news regarding the proposed project spreads, expectations regarding possible employment opportunities may take root. Consequently, the area surrounding the site may experience an influx of job seekers. On the Remaining Extent of the Farm Bokpoort 390, construction of the Bokpoort I facility has recently been completed and there has been an influx of people and heavy equipment to the south of the project area. The proposed project would similarly result in the influx of potential job seekers to this area. Population influx is rated as a **moderate** impact (**SP = 52**) before mitigation and **moderate** (**SP = 30**) with mitigation.
- Economic benefits – as this is a small-scale operation, the economic benefits associated with the proposed project are expected to be somewhat limited but nevertheless positive. Agriculture, forestry and fishing (33%) and Wholesale and retail trade, catering and accommodation (19%) are the highest GVA in the !Kheis LM as of 2010. Renewable solar activities will enhance this contribution and is likely to have multiplier effects at regional and national level. This impact is rated as a positive **moderate** impact (**SP = +39**) before mitigation and positive **moderate** (**SP = +64**) with mitigation.
- Change in land use – should the project be commissioned, the land use will change from grazing land to solar energy production. The site will be cleared of all vegetation during the construction phase and topsoil will be subjected to wind erosion, possibly resulting in displacement for other land uses during the project's construction and operational phases. This impact is rated as **moderate** (**SP = 52**) before mitigation and **moderate** (**SP = 30**) with mitigation.

The following mitigation measures are proposed:

- Appointing one or more community liaison officers to manage the interaction with the neighbouring residents, other members of the public and the authorities.
- Source local labour as far as possible with an emphasis on employing youth and women.
- If specific skilled positions cannot be sourced within the local municipality, they should be sourced at district, province or national level first before looking at international workers.
- Development of recruitment and procurement policies for ACWA Power and all Contractors, which include maximising the usage of local service providers and utilisation of local labour should be a key requirement in the tender documentation.
- Launch an awareness/ educational campaign in conjunction with the local municipality and health authority to address the social and health issues in the local communities associated with the influx of foreign workers.
- Communicating information regarding the transport routes, peak operational times, associated hazards and precautionary measures to the Ward councillor as well as any relevant community organisations;
- Ensuring that project information is communicated formally, consistently and responsibly to avoid misunderstandings and the creation of unrealistic expectations.
- Setting up a formal grievance mechanism for the public to lodge issues. All complaints must be recorded, followed up and resolved as expeditiously as possible.
- Preventing the development of ad-hoc roadside dwellings, shops and so forth on or adjacent to the project site.

⁸⁹ Smith, T; de Waal, D. 2016. Socio-economic Impact Assessment for the proposed 75 MW Photovoltaic (PV2) Solar Facility (Bokpoort II Solar Development). Golder Associates Africa (Pty) Ltd.

- The Contractor, in line with the relevant socio-economic focus of the !Kheis LM and ACWA Power's personnel policies, must develop an appropriate exit strategy for temporary employees.
- Construction traffic past community infrastructures such as schools, crèches, sporting facilities, etc. must be properly managed and the rules of the road should be strictly enforced.
- Limiting construction-related road use to daylight hours and avoiding the movement of heavy vehicles during peak traffic hours as far as practicable.
- Developing a database of local job seekers, with skills levels and employment history, before commencing with personnel recruitment for the operational phase.

7.3.15.2 Operations

- Employment opportunities – The operational phase will require about 20 – 40 employees. Job creation in the medium to long-term during the operational phase is generated by operational components including security, drivers, administration, and operator's positions. This means that local communities can potentially take maximum advantage of any potential employment opportunities to be created by the proposed activities. It should be noted that some positions may require scarce skills, which may not be readily available in the labour sending area. Therefore, a certain percentage of the workforce will potentially be recruited from elsewhere in the district or province. At this stage of the project, the number of foreign employment opportunities is uncertain. The impact is rated as a positive **low** impact (**SP = +24**) before mitigation and a positive **moderate** impact (**SP = +30**) with mitigation.
- Training and skills development – the primary aim of the training and skills development programme is to enable employees to reach their realistic developmental aspirations and diversify their skills to be re-employable at the point of possible operation downscaling or retrenchment. Potential community development projects can be designed to contribute to the growth and education of the local communities as well as infrastructure development where needed. ACWA Power would need to allocate funds to develop community projects based on the requirements in these areas. The impact is rated as a positive **moderate** impact (**SP = +30**) before mitigation and a positive **moderate** impact (**SP = +52**) with mitigation.
- Continued economic benefit – the use of renewable energy resources like solar power contributes to diversifying the fuel sources used for energy production which improves electricity production efficiency. Operational expenditure for the proposed project will contribute to the local and district municipal economies. The projected operational wage bill from the 200 temporary and up to 40 permanent employees would also provide an injection of cash into the local economy. This will stimulate the formal and informal retail and service sectors and secondary industries, having a positive multiplier effect on the local economy. The impact is rated as a positive **moderate** impact (**SP = +39**) before mitigation and a positive **moderate** impact (**SP = +64**) with mitigation.
- Continued population influx – The increase in population to the area should stable out during the operational phase as the potential job opportunities are small and the influx would slow. The prevalence of the other impacts associated with population influx such as an increase in crime and property damage could still affect the existing communities, but these are anticipated to be of low significance. The impact is rated as a **moderate** impact (**SP = 36**) before mitigation and a **low** impact (**SP = 18**) with mitigation.

Mitigation measures to be implemented:

- Recruiting personnel from the local labour pool to the extent practicable.
- Preferentially procuring goods and services from local suppliers wherever practicable.
- Establishing a skills development programme to increase employees' value to ACWA Power and their employability in the broader labour market.
- Implementing effective traffic management measures to minimise the impact of project-related traffic on other road users.
- Prioritising safety for employees and visitors.
- Maintaining the grievance management system.

- Developing a retrenchment plan and procedures in consultation with employees.
- Keeping employees, including service providers under contract, informed about the general financial health of the PV plants and the remaining life of the project; and
- Developing a post-closure land use plan in consultation with local authorities and members of the public.

7.3.15.3 Closure and Rehabilitation

The activities undertaken during this phase will be similar to those of the construction phase, but the duration will be shorter. Most of the negative environmental impacts experienced during the construction and operational phases will be reversed over time, but the positive socio-economic impacts of job creation and cash injection into the local economy will fall away upon closure of the operation.

A reduction in employment is rated as a **moderate** impact (**SP = 56**) before mitigation and a **low** impact (**SP = 20**) with mitigation. The change in economic benefits from energy generation to agriculture is rated as a **high** impact (**SP = 80**) before mitigation and a **moderate** impact (**SP = 52**) with mitigation. The dependency on the project sustaining the local economy would be **moderate** impact (**SP = 48**) before mitigation and a **low** impact (**SP = 22**) provided that alternative funding is sourced.

The following mitigation measures are recommended:

- Proactive skills development and training of employees to enhance their value in the labour market and thereby their chances of finding employment after project closure.
- Development of a retrenchment plan in consultation with employees, starting at least five years before closure.
- Assisting redundant employees to find alternative employment as far as practicable.
- Providing training and start-up assistance to employees who want to start their own businesses.
- Leaving intact such infrastructure as can be used by the subsequent landowner(s).

7.3.15.4 Cumulative

- Employment opportunities – the combined project indicates employment opportunities for approximately 200 local unskilled workers during construction peak. Although it is uncertain at this stage, what the duration of the construction peak will be, 200 local employment opportunities will contribute significantly to livelihoods and the local economy. This conclusion is based on the assumption that by far the majority (if not all) of the 200 opportunities will be sourced from the local communities, focused on Groblershoop and Wegdraai, and other communities within a radius of 20 to 30km from the site. Using local employees must be a key focus area, if the positive impacts are to be maximised. The use of local employees also minimise the range of potential adverse social impacts, such as cultural disparity between local people and large numbers of newcomers, social mobilisation to protect local jobs and health, safety and security concerns. Even though the number of direct job opportunities will be temporary, there is the potential for increased indirect employment through the supply chain vendors and service providers and associated increased local spend as a result of the project activities.
- Population influx – the influx of temporary workers in search of jobs is a reality in the Northern Cape. It has significant impacts to the existing communities based on limited available resources to service a larger population in a stark and arid landscape. An impact directly linked to foreign workers, is related to social and intimate relations between the foreigners, who are here for only a short duration, and the local population. This often results in family stress, health impacts, and the socio-economic load on households to look after children, whose fathers have departed and make little contribution to their emotional and financial upkeep. Although any influx of workers into the area may result in such impacts, experience has shown that this is most prominent in the case of foreign workers.
- Continued economic benefits – The use of renewable energy resources like solar power contributes to diversifying the fuel sources used for energy production which improves electricity production efficiency.

7.4 Summary of Environmental Impacts

7.4.1 Construction Phase

Table 48 below summarises those impacts directly related to the construction phase of the proposed project and provides a significance rating for each impact before and after mitigation. The construction period for PV plant including ICE is estimated to be 12 - 18 months.

Table 48: Environmental impact assessment matrix for the construction phase

Potential Environmental Impact (Construction)	Environmental Significance											
	Pre-mitigation						Post-mitigation					
	M	D	S	P	SP	Rating	M	D	S	P	SP	Rating
Geotechnical												
The fuel storage tanks associated with the ICE, would typically induce foundation pressures of 100 - 120kPa beneath the envisaged ring-beam, when wind loads are considered. The ICE exhaust stack could be up to 70m in height with varying distances of horizontal runs that would require support e.g. lattice structures.	4	4	1	4	36	Mod	2	4	1	4	28	Low
Soils and Agricultural Potential												
Agricultural grazing land directly occupied by the development infrastructure which includes all associated infrastructure, will become unavailable for agricultural use.	2	4	1	5	35	Mod	2	4	1	5	35	Mod
Soil degradation erosion, topsoil loss and contamination.	2	3	1	3	18	Low	2	3	1	2	12	Low
Hydrogeology												
The groundwater quality can be impacted by spillage of fuels, lubricants, chemicals from construction equipment, vehicles and temporary workshop during the construction phase.	6	2	2	3	30	Mod	4	2	2	2	16	Low

Potential Environmental Impact (Construction)	Environmental Significance											
	Pre-mitigation						Post-mitigation					
	M	D	S	P	SP	Rating	M	D	S	P	SP	Rating
Infiltration potential/ aquifer vulnerability.	6	1	1	2	16	Low	6	1	1	2	16	Low
Impact on receptors.	2	2	2	2	12	Low	2	2	2	2	12	Low
Surface Water												
Spillage of fuels, lubricants and other chemicals, increased run-off due to vegetation and veld removal, potential pollution transport via run-off of rainfall from disturbed areas and erosion.	6	2	2	3	30	Mod	4	2	2	2	16	Low
Ecology												
Loss of extent of modified habitats within the project footprint (direct impacts on natural vegetation).	4	5	1	5	50	Mod	2	4	1	5	35	Mod
Introduction/ spread of exotic invasive species.	6	5	2	4	52	Mod	2	2	1	3	15	Low
Loss/ disturbance of flora and fauna species of conservation concern.	8	2	4	4	56	Mod	4	4	1	4	36	Mod
Loss/ disturbance of other fauna species.	6	4	1	5	55	Mod	4	4	1	3	27	Low
Reduction in extent of natural habitats, systems of conservation concern.	8	5	1	3	42	Mod	4	5	0	2	18	Low
Bats												
Reduction in foraging habitat due to vegetation clearance.	6	4	1	5	55	Mod	2	4	1	4	28	Low
Disturbance and displacement due to construction noise and lighting.	6	2	1	4	36	Mod	4	1	1	4	24	Low
Avifauna												
The removal and/ or destruction and/ or alteration of habitat used by birds, may impact on the foraging and/ or breeding	8	4	2	5	70	Mod	8	3	1	5	60	Mod

Potential Environmental Impact (Construction)	Environmental Significance											
	Pre-mitigation						Post-mitigation					
	M	D	S	P	SP	Rating	M	D	S	P	SP	Rating
success of certain species, and will lead to numerous birds being displaced from the projects site and needing to find suitable available habitat elsewhere.												
Birds are disturbed and displaced from the project site and surrounding areas due to construction activities and associated noise etc.	8	2	2	4	48	Mod	6	2	2	3	30	Mod
Air Quality												
The construction phase of the generator sets will result in emission of particulate matter, and to a lesser extent, gaseous pollutants. Ambient pollutant concentrations and nuisance dustfall rates will increase during the construction period.	2	1	2	3	15	Low	2	1	1	3	12	Low
Heritage												
No sites, features or objects of cultural significance were identified.	-	-	-	-	-	-	-	-	-	-	-	-
Palaeontology												
Disturbance, damage, destruction or sealing-in of scientifically important fossil remains preserved at or beneath the ground surface within the development area, most notably by surface clearance and bedrock excavations during the construction phase.	2	5	1	2	16	Low	2	5	1	1	8	Low
Traffic												
The increase in traffic, and especially of vehicles carrying heavy loads will cause an increase in deterioration of the road network.	8	2	2	5	60	Mod	4	2	2	3	24	Low

Potential Environmental Impact (Construction)	Environmental Significance											
	Pre-mitigation						Post-mitigation					
	M	D	S	P	SP	Rating	M	D	S	P	SP	Rating
Increase in dust is only applicable to the gravel roads. Dust is generated due to heavy vehicles and high speeds.	8	2	2	5	60	Mod	2	2	2	3	18	Low
Increase in traffic volumes impacting LOS of the infrastructure:	8	2	2	5	60	Mod	2	2	2	4	24	Low
Road safety deterioration due to dust and speeding, causing drivers to lose control on the gravel roads.	4	2	2	4	32	Mod	2	2	2	3	18	Low
Visual												
Visibility and dust plumes generated at the construction site.	6	2	3	4	44	Mod	4	2	2	2	16	Low
Generation of dust plumes from construction traffic on the access roads.	4	2	3	2	18	Low	4	2	2	2	16	Low
Noise												
Impacts during construction i.e. site preparation, demolition, earthworks, generator enclosure construction, storage and handling infrastructure and utilities construction and delivery, installation and commissioning of plant machinery.	2	2	2	2	12	Low	2	2	1	1	5	Low
Socio-economic												
Employment opportunities.	6	2	2	3	+30	Mod	6	2	2	4	+40	Mod
Population influx.	8	3	2	4	52	Mod	6	2	2	3	30	Mod
Economic benefits.	6	4	3	3	+39	Mod	8	4	4	4	+64	Mod
Change in land use.	6	4	3	4	52	Mod	4	4	2	3	30	Mod

7.4.2 Operations Phase

Table 49 below summarises those impacts directly related to the operations phase of the proposed project and provides a significance rating for each impact before and after mitigation. The operational period of individual plant will be in accordance with the power purchase agreement i.e. 20 years.

Table 49: Environmental impact assessment matrix for the operations phase

Potential Environmental Impact (Operations)	Environmental Significance											
	Pre-mitigation						Post-mitigation					
	M	D	S	P	SP	Rating	M	D	S	P	SP	Rating
Hydrogeology												
The groundwater quality can be impacted by spillage of fuel and leakage from the ICE from operations and maintenance activities.	6	3	1	3	30	Mod	4	3	1	2	16	Low
Surface Water												
Spillage of fuels (diesel), lubricants and other chemicals, during operations and erosion.	6	3	1	3	30	Mod	4	3	1	2	16	Low
Soils and Agricultural Potential												
Soil contamination during the operational phase.	6	4	1	3	33	Mod	4	4	1	2	18	Low
Ecology												
Spread of invasive plant species.	6	5	2	4	52	Mod	2	2	1	3	15	Low
Direct loss (injury/ mortality) of fauna species via roadkill.	8	4	2	5	70	Mod	4	4	2	4	40	Mod
Disturbance of faunal species of conservation concern – site lighting.	6	4	2	5	60	Mod	4	4	2	2	20	Low
Disturbance of faunal species of conservation concern – barrier to movement.	6	4	2	4	48	Mod	6	4	2	3	36	Mod

Potential Environmental Impact (Operations)	Environmental Significance											
	Pre-mitigation						Post-mitigation					
	M	D	S	P	SP	Rating	M	D	S	P	SP	Rating
Bats												
Operation of two ICE (five in total will impact the foraging and commuting of bats within and around the development area as the plants have a barrier effect to their normal behaviour and use of the area.	8	4	1	4	52	Mod	4	4	1	3	27	Low
Change of bat community utilizing development area due to security lighting.	6	4	1	4	44	Mod	2	4	1	4	28	Low
Collision of bats with PV panels and infrastructure.	4	1	1	2	12	Low	4	1	1	1	6	Low
Avifauna												
Birds are disturbed and displaced from the project site and surrounding areas, or from the grid connection servitude and surrounding areas, due ongoing operational and maintenance activities.	8	4	2	4	56	Mod	6	4	2	2	24	Low
Birds colliding with infrastructure - birds may be attracted to the reflective surfaces which may be mistaken for large water bodies and can cause disorientation of flying birds, resulting in injury and/ or death.	6	4	1	5	55	Mod	4	4	1	3	27	Low
The development forms a physical barrier to movement of birds across the landscape, alters migration routes and increases distances travelled and energy expenditure for hunting or foraging.	6	4	3	3	39	Mod	4	4	2	2	20	Low
Air Quality												
The operation of the generator sets will result in emissions of SO ₂ , CO, particulate matter, and VOC emissions.	4	4	2	3	30	Mod	2	4	1	3	21	Low

Potential Environmental Impact (Operations)	Environmental Significance											
	Pre-mitigation						Post-mitigation					
	M	D	S	P	SP	Rating	M	D	S	P	SP	Rating
Ambient pollutant concentrations and nuisance dustfall rates will increase during the periods of operation.												
The operation of the generator sets will result in emissions of NO _x . Ambient pollutant concentrations will increase during the periods of operation.	4	4	2	3	30	Mod	2	4	2	3	24	Low
Climate Change												
The annual CO ₂ -e emissions from the power station operations using diesel would, at maximum in the first year assuming one 15 day reliability test where the 56 generators operate continuously during dispatchable hours, contribute 0.004% to the South African “energy” sector total and represent a contribution of 0.004% to the National GHG inventory total (based on the published 2015 National GHG Inventory).	2	4	5	3	33	Mod	2	4	5	3	33	Mod
Traffic												
Deterioration of road conditions, dust generation, traffic volumes and road safety conditions during the operations phase.	2	4	2	2	16	Low	2	4	2	2	16	Low
Visual												
Visibility of the development to the vast majority of the receptor locations in the study area.	6	2	4	2	24	Low	6	2	4	2	24	Low
Introduction of new sources of lighting to a relatively unlit night-time environment.	6	2	4	2	24	Low	4	2	4	2	20	Low

Potential Environmental Impact (Operations)	Environmental Significance											
	Pre-mitigation						Post-mitigation					
	M	D	S	P	SP	Rating	M	D	S	P	SP	Rating
Noise												
Noise generated from generator engine, exhaust and cooling fans.	4	4	2	4	40	Mod	4	4	1	2	18	Low
Socio-economic												
Employment opportunities.	4	2	2	3	+24	Low	4	4	2	3	+30	Mod
Training and skills development.	4	4	2	3	+30	Mod	6	5	2	4	+52	Mod
Continued economic benefits.	6	4	3	3	+39	Mod	8	4	4	4	+64	Mod
Continued population influx.	6	4	2	3	36	Mod	4	3	2	2	18	Low

7.4.3 Closure and Rehabilitation

Table 50 below summarises those impacts directly related to the operations phase of the proposed project and provides a significance rating for each impact before and after mitigation. The closure and demolition of the infrastructure will take approximately 3 - 6 months. The rehabilitation period to restore the area to grazing will be approximately 6 - 12 months.

Table 50: Environmental impact assessment matrix for the closure and rehabilitation phase

Potential Environmental Impact (Closure & Rehabilitation)	Environmental Significance											
	Pre-mitigation						Post-mitigation					
	M	D	S	P	SP	Rating	M	D	S	P	SP	Rating
Soils												
Soil degradation can result from erosion, topsoil loss and contamination.	2	3	1	3	18	Low	2	3	1	2	12	Low

Potential Environmental Impact (Closure & Rehabilitation)	Environmental Significance											
	Pre-mitigation						Post-mitigation					
	M	D	S	P	SP	Rating	M	D	S	P	SP	Rating
Hydrogeology												
The groundwater quality can be impacted by spillage of fuels, lubricants, chemicals from closure and rehabilitation activities.	6	1	1	3	24	Low	4	1	1	3	18	Low
Surface Water												
Erosion of bare surfaces and spillages of waste materials and hydrocarbons from vehicles could cause surface water contamination.	6	2	1	3	27	Low	4	2	1	2	14	Low
Ecology												
Spread of invasive plant species.	6	4	3	5	65	Mod	4	2	1	3	21	Low
Bats												
Disturbance and displacement due to decommissioning noise and lighting.	6	2	1	4	36	Mod	4	1	1	4	24	Low
Air Quality												
The decommissioning phase of the generator sets will result in emission of particulate matter, and to a lesser extent, gaseous pollutants. Ambient pollutant concentrations and nuisance dustfall rates will increase during the decommissioning period.	2	1	2	3	15	Low	2	1	1	3	12	Low
Traffic												
Significantly less traffic than construction and operational phases but will have some effect on road safety and wear and tear.	6	2	2	4	40	Mod	4	2	2	2	16	Low

Potential Environmental Impact (Closure & Rehabilitation)	Environmental Significance											
	Pre-mitigation						Post-mitigation					
	M	D	S	P	SP	Rating	M	D	S	P	SP	Rating
Visual												
Generation of dust plumes from traffic on the access roads.	4	2	3	2	18	Low	4	2	2	2	16	Low
Noise												
Noise generated during closure and rehabilitation activities.	2	2	2	2	12	Low	2	2	1	1	5	Low
Socio-economic												
Reduced employment.	8	4	2	4	56	Mod	6	2	2	2	20	Low
Reduced economic benefit.	8	5	3	5	80	High	6	5	2	4	52	Mod
Dependency on project sustaining local economy.	8	5	3	3	48	Mod	6	3	2	2	22	Low

7.4.4 Cumulative

Table 51 below summarises those impacts directly related to the construction phase of the proposed project and provides a significance rating for each impact before and after mitigation.

Table 51: Summary of cumulative impacts

Discipline	Impact and Significance
Agriculture	<p>Loss or degradation of agricultural land, with a consequent decrease in agricultural production.</p> <p>The cumulative impact of loss of agricultural land use is assessed as having low significance.</p>
Ecology	<p>Site clearance within the footprint of the development will result in a combined loss of approximately 1ha (0.5ha per ICE plant) of existing vegetation within the study area.</p> <p>Potential residual (post-mitigation) impacts of the PV plants including the ICE in the region relate to potential indirect impacts on fauna (such as increased incidences of road-kill) and exacerbation of the loss of remaining areas of natural habitat and changes to the landscape that may affect migration patterns.</p> <p>Because of the comparatively small size of the proposed developments, the significance of anticipated cumulative impacts are expected to be of a low significance.</p>
Bats	<p>The proposed PV plant developments as well as planned solar projects in the area above will primarily negatively impact bats by reducing foraging areas and roosting resources within the greater area. However, the Orange River and its riparian vegetation is a more important source of drinking water and prime foraging grounds for bats than the surrounding areas that the proposed projects are located within. With the implementation of mitigation at each of the solar projects in the area, the cumulative impact will be reduced.</p>
Avifauna	<p>The cumulative impact of all the proposed developments on birds is difficult to estimate as the specifics of the final technologies to be utilised at each site, and levels of habitat rehabilitation within the project sites, is unknown. The cumulative impact will be significantly reduced to moderate if the mitigation measures are implemented at all surrounding developments.</p>
Air Quality	<p>Cumulative impacts (elevated particulate matter and nuisance dustfall during high wind events) are likely to be limited in duration and frequency and of low significance with the implementation of mitigation measures.</p>

Discipline	Impact and Significance
	<p>Cumulative effects (operations) are likely to be limited since ambient air quality in the air is considered good and the mitigated impact of the generators is likely to be a localised impact.</p> <p><u>The cumulative impact of the proposed 49.5MW thermal power generation facility is likely to make the largest impact on hourly NO₂ concentrations with potential exceedances of the NAAQ limit concentration. The number of exceedances is likely to be within the frequency allowed by the NAAQS.</u></p>
Climate Change	<p><u>The operation of the generators will contribute to projected impacts at a local, national, and global scales (albeit at through a relatively small annual contribution). The impact of global climate change is likely to have a largely permanent impact on the global ecosystem with potential irreplaceable loss of resources.</u></p> <p><u>Assuming that the hybrid facility replaces generative capacity from other fossil fuel sources, the facility could lower South Africa's GHG emissions from the Energy sector since the ICE plant provides only support to the PV arrays and BESS which provide renewable energy at a lower CO₂-e emission per unit electricity.</u></p>
Heritage	<p>The project is located in an area where little such development has taken place, with the implication that the cumulative impact would be very low</p>
Visual	<p>The proposed development will be located immediately adjacent to the Bokpoort I plant, so when viewed from the surrounds it will form part of a visual environment that is already transformed from a natural context. The proposed development will add to the transformation of the landscape in the local area, thus increasing the cumulative visual effect on the landscape. However, the remoteness of the location lowers the overall cumulative visual impact in a wider study area context.</p>
Noise	<p>The proposed cumulative operational noise levels at do not exceed the existing baseline noise levels by 7dB during day or night-time and thus does not constitute a noise disturbance (low to medium significance). However, the generator noise will be audible during some periods of the daytime and night-time periods as the measured baseline noise levels vary between 20 and 40dBA which will cause noise nuisance complaints. If noise mitigation is implemented, noise nuisance complaints will be reduced significantly during the daytime and night-time periods.</p>
Socio-economic	<p>Potential cumulative impacts include employment opportunities during construction, influx of people into the area seeking employment and continued economic benefits.</p>

8 ENVIRONMENTAL AND CUMULATIVE IMPACT STATEMENT

8.1 Key Findings

8.1.1 Geotechnical

The fuel storage tanks associated with the ICE, would typically induce foundation pressures and the ICE exhaust stack would require support. Foundation pressure could be mitigated using conventional pad foundations. Piled foundations could be required for lattice stack structures.

8.1.2 Soils and Agricultural Potential

The proposed ICE will be developed on land which is of low agricultural potential and is not suitable for cultivation. No agricultural sensitive areas occur within the proposed site and no part of it is therefore required to be set aside from the development. Because of the low agricultural potential of the site, and the consequent low agricultural impact, there are no restrictions relating to agriculture which would preclude authorisation of the proposed development.

8.1.3 Hydrogeology

The potential impacts associated with the development of the ICE will be primarily from spillage of fuels, lubricants and chemicals and will be of a low environmental significance provided that mitigation measures are implemented.

8.1.4 Surface Water

A Stormwater Management Plan (SWMP) must be implemented during the construction phase of the project. Spillage of fuels, lubricants and other chemicals must be cleaned up immediately and disposed of at an appropriately licenced landfill site. Mitigation for spillage or leakages must include bunded areas to store chemicals and/ or fuel.

8.1.5 Ecology

The proposed development will potentially affect biodiversity in three main ways: (i) loss in extent of vegetation communities and loss and associated disturbance of species of conservation concern during construction; (ii) effects on fauna species of conservation concern as a result of site lighting, security fencing and increased road traffic during operation, and (iii) the spread of invasive species and potential contamination of remaining natural (surrounding) ecosystems during closure. A review of the anticipated impacts associated with this type of development on the ecological environment indicates that none of the anticipated impacts can be highlighted or construed to represent an unacceptable or severe threat to sensitive biological or biodiversity components within the study area and wider region.

8.1.6 Avifauna

As the development footprint of the proposed ICEs fall entirely within the original development footprint assessed for the original Environmental Authorisations and the data collected for those impact assessments remain valid and sufficient to inform the assessment of the current proposed ICE additions.

Avian species particularly sensitive to disturbance would unlikely be in the vicinity of the ICEs due to the routine operational activities that would already be present on the site.

An increase in nesting opportunities on the ICE infrastructure would not likely attract target or priority species to the facility as these species generally avoid areas of human traffic and therefore the presence of ICEs will not increase the likelihood or significance rating of impacts associated with electrocutions or collisions beyond those already assessed. Mitigation measures have been recommended for inclusion the EMPr (**Appendix E**).

8.1.7 Air Quality

The main findings include the following:

- During the construction phase, impacts are likely to be localised and of short duration and a low rating was determined for the impact associated with the construction phase of the project.
- Compliance with hourly, daily, and annual NAAQS under normal operations is likely across the domain and at the receptors for SO₂, particulate matter, (PM₁₀ and PM_{2.5}), and carbon monoxide (CO).
- Hourly exceedances of the NO₂ NAAQ limit concentration is likely both on- and off-site, however, the total number of exceedances at the closest receptor is likely to be fewer than those allowed by the NAAQS. Simulated annual average NO₂ concentrations are lower than the NAAQS across the domain.
- Compliance with the chronic inhalation guidelines for volatile organic compounds (VOCs) and diesel particulate matter (DPM) are likely off-site.
- The excess cancer risk due to exposure to DPM was calculated to be low (on and near site) and very low at closest receptors and across the remainder of the domain.
- The United Nations Economic Commission for Europe (UNECE) Convention on Long Range Trans-boundary Air Pollution Limits) critical levels were used to assess the potential for impact of annual SO₂ and NO₂ concentrations on vegetation via various measures of productivity and reproductive success. Impacts to vegetative productivity are unlikely due to the project across in the domain or at any receptors.
- The impact of the facility was simulated to be below the NDCR. Mitigation measures for control vehicle entrainment dust emissions are recommended along the delivery route.
- A low rating was determined for the impact of criteria air pollutants associated with the normal operation of the project (2 hours per week).
- Cumulative impact of the project and the other sources in the area is likely to exceed the NAAQ limit concentration off site but not at the closest receptor and a low rating was determined for the mitigated impact of the project in isolation and in the context of other air pollution sources in the vicinity.

8.1.8 Climate Change

The annual CO₂-e emissions from the ICE operations using diesel would, at maximum, contribute 0.037% to the South African “energy” sector total and represent a contribution of 0.004% to the National GHG inventory total (based on the published 2015 National GHG Inventory). However, it is noted here that the thermal power generation facilities are a backup to the renewable energy generated by the solar PV arrays and therefore the actual emissions are likely to be much lower than estimated on the assumed operating hours.

8.1.9 Heritage and Palaeontology

Stone Age lithics dating to the MSA are found only as low-density surface scatters. The low density of the lithic scatters is, on archaeological grounds, viewed to be of low significance and require no further action. No sites, features or objects of cultural significance are known to exist in the development area, and there would be no impact as a result of the proposed development. Should archaeological sites or graves be

exposed in other areas during construction work, it must immediately be reported to a heritage practitioner so that an investigation and evaluation of the finds can be made.

No significant impacts on fossil heritage are anticipated during the construction, operational and closure phases of the project.

8.1.10 Traffic

Travel to and from the development site by personnel, deliveries and visitors will add to the existing traffic on the approach roads, affecting road safety, create dust from unpaved roads and road surface quality as experienced by existing road users during the construction phase.

The operational phase will not generate heavy vehicle volumes when compared to the construction phase. It should be reiterated that the ICE will only be operated when the solar resources are not available in extreme weather conditions. The ICE will not have long periods of operating time, hence the load factors of the ICE shall be low. The delivery of diesel will be by road tanker with current capacity of 32T - 45T per load, current first fill to site storage is expected with monthly top-up fills planned as required. Fuel to be transferred on site through a purpose build fuel offloading facility and stored in on-site storage tanks. The fuel storage system will be able to handle fuel for at least three consecutive days of full operation.

8.1.11 Visual

The addition of the ICE is not expected to significantly alter the area of potential visual exposure and is therefore not expected to significantly alter the influence of the Solar Energy Facility (SEF) on areas of higher viewer incidence (observers traveling along the national, arterial/ main, or major secondary roads within the region) or potential sensitive visual receptors (residents of homesteads in close proximity to the SEF).

In consideration of the proposed addition of the ICE, there is no (zero) change to the significance rating compared with the original Visual Impact Assessment Report and no additional visual impacts are envisaged.

8.1.12 Noise

The outcome of the assessment indicated that noise mitigation is required during the construction phase and operational phase. Key mitigation options include:

- Construction Phase - The most important mitigation option is to ensure the construction occurs during day-time hours.
- Mitigation requires engineering input from a qualified acoustic consultant. Further to this annual noise measurements programme is recommended.

With mitigation measures implemented the proposed five (two new and three previously authorised) 9.9MW Generator Plants would comply to the Noise Control Regulations (GN R.154 of 1992). In terms of noise assessment, the project does not present a fatal flaw. The project should be authorised in terms of noise, with mitigation measures adhered to.

8.1.13 Socio-economic

The proposed project will be a positive impact as this will provide further support to the national grid therefore aiding in provide electricity security to the region and the country. The potential job creation at the construction phase of the project will be a positive for the local and regional economy as unemployment in

the country is increasing. An assured and diversified electricity generation mix is a key step in attracting investors into South Africa and is key for the growth and development.

8.2 Environmental Impact Statement

The project, in the EAP's opinion, does not pose a detrimental impact on the receiving environment and its inhabitants and potential impacts can be mitigated significantly. There are no fatal flaws prohibiting the project from going ahead. The preferred fuel source would be diesel.

8.3 Cumulative Impact Statement

Table 52 provides the details of solar projects within a 30km radius of the proposed project as obtained from the DFFE Renewable Energy EIA Application Database for South Africa (2020)⁹⁰. Figure 51 provides the cumulative map overlaid with the layout.

From a cumulative impact perspective, the proposed project will be developed within a REDZ (REDZ 7) which is earmarked for large scale solar energy facilities and is within the Northern Corridor Strategic Transmission Corridor. Further to this, the development is preferable, from an impact point of view as well as from practical considerations, to rather have a concentrated node of renewable energy development within one area, than to spread out the same number of developments over a larger area.

⁹⁰ https://egis.environment.gov.za/renewable_energy

Table 52: Renewable energy projects within 30km of the proposed project

DFFE Ref	Applicant	Project Title	Technology	Megawatt	Project Status
14/12/16/3/3/2/906	Marang Solar Farm (Pty) Ltd	Proposed Marang Solar Project and its associated infrastructure on the Blauwbospan No 113, near Groblershoop in the Northern Cape	Solar PV	-	In process
14/12/16/3/3/2/907	Marang Solar Farm (Pty) Ltd	Proposed Marang Solar Project and its associated infrastructure on the Blauwbospan No 113, near Groblershoop in the Northern Cape	Solar PV	-	In process
12/12/20/2583	To review	The proposed Inyanga Energy Project 6 on Portion 15 of the farm O'poort 384, !Kheis Local Municipality, Northern Cape Province	Solar PV	75	Approved
14/12/16/3/3/2/701	Neo Bio Energy	Proposed construction of 100MW !Kheis Solar One CSP and associated infrastructure, Northern Cape	Solar CSP	100	Withdrawn/Lapsed
14/12/16/3/3/1/909	Maxwell Moss and Associates (Pty) Ltd	Proposed expansion of the Prieska Solar Power Plant within Siyathemba Municipality, Prieska, Northern Cape	Solar CPV	19	Approved
14/12/16/3/3/1/909	Siyathemba Solar One (Pty) Ltd	Proposed expansion of the Prieska Solar Power Plant within Siyathemba Municipality, Prieska, Northern Cape	No Technology	-	Approved
14/12/16/3/3/2/640	Scatec Solar (Pty) Ltd	The proposed establishment of an 86MW Photovoltaic Solar Facility on portion 4 of the farm Rooilyf No. 389, Registration Division, Zf Mcgawu Local Municipality, in the Northern Cape Province	In Process	86	In process
14/12/16/3/3/2/738	SolAfrica Photovoltaic Energy (Pty) Ltd	Proposed SolAfrica Sand Draai 75MW PV Project in the !Kheis Local Municipality	Solar PV	75	In process
12/12/20/1920/AM5	ACWA Power SolAfrica Bokpoort CSP Power Plant (Pty) Ltd	Proposed Bokpoort 75MW Concentrating Solar Thermal Power Plant and its associated infrastructure in the Siyanda District, Northern Cape Province	Solar CSP	75*	Approved
12/12/20/1920	SolAfrica Thermal Energy Pty Ltd	Proposed 75MW Concentrating Solar Thermal Power Plant and its associated infrastructure in the Siyanda District, Northern Cape Province	Solar CSP	75*	Approved
14/12/16/3/3/2/570/A M1	Gestamp Asetym Solar South Africa (Pty) Ltd	Proposed Kheis Solar Park 1 PV project on a site South East of Upington within the !Kheis Local Municipality	Solar PV	-	Approved

*corrected

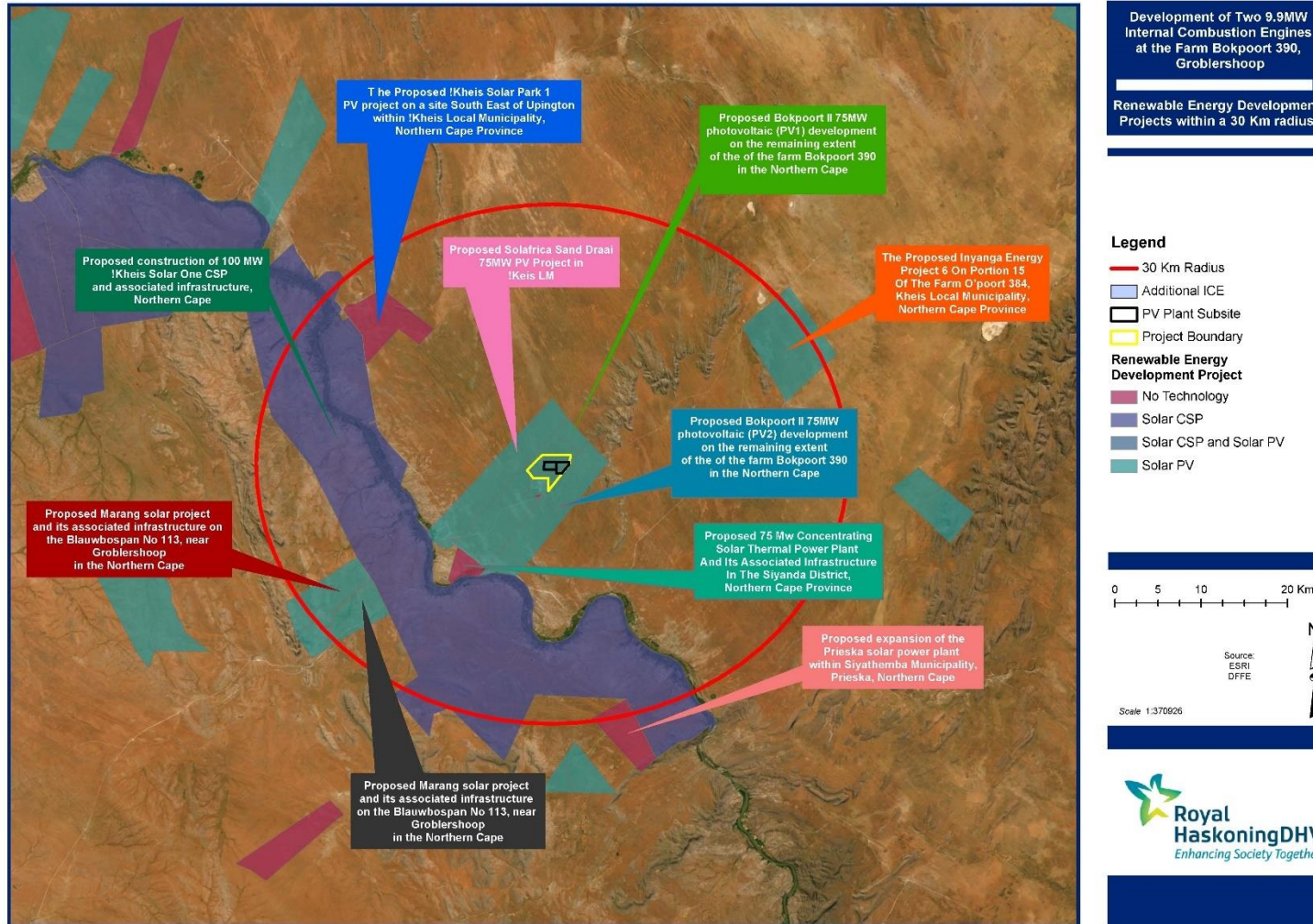

Figure 51: Renewable energy projects within 30km of the proposed project



Royal
HaskoningDHV

8.4 Sensitivity Map

Project related

The sensitivity map overlaid with the layout is presented in Figure 52 must be considered when determining if the proposed project should be authorised.

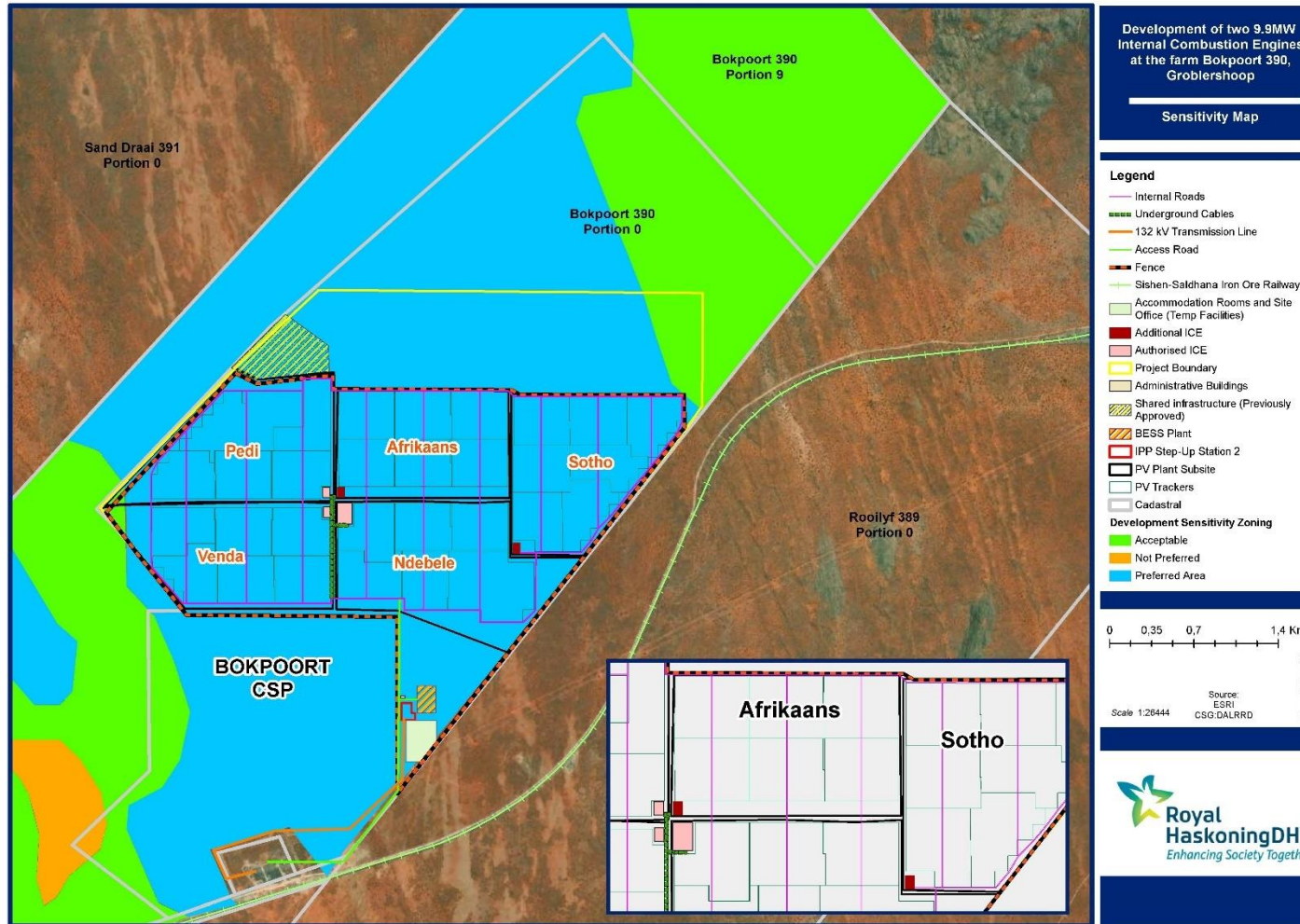

Figure 52: Sensitivity map

8.5 Assumptions, Uncertainties or Gaps in Knowledge

The BA process followed the legislated process required and as governed and specified by the EIA Regulations 2014 (as amended). Inevitably, when undertaking scientific studies, challenges and limitations are encountered. For this specific BA, the following should be noted:

- All information provided by the Engineering team, previous studies conducted for the ten PV plants and seven ICE was correct and valid at the time it was provided.
- Although all effort was made by the project team to identify all environmental social and health aspects, impacts and mitigation measures, errors and omissions may have occurred.
- The EAP does not accept any responsibility in the event that additional information comes to light at a later stage of the process.
- All data from unpublished research is valid and accurate.
- The BA study does not address Occupational Health and Safety as required by IFC Performance Standard 2. ACWA Power has established health and safety policies and procedures for Bokpoort I and will develop appropriate environmental, health, safety, security and quality control procedures applicable to the development prior to the commencement of construction.
- Every effort was made to engage I&APs and stakeholders, however not every I&AP and stakeholder may have been consulted. A grievance mechanism must be put in place at the commencement of construction through which I&APs and stakeholders are able to raise grievances and continue to contribute their concerns and issues with the project team.

8.6 Recommendations

8.6.1 Recommendations to the CA

The preferred fuel alternative would be diesel. The actual date of construction is not available as this will depend on the DMRE. Construction is expected to commence by June 2022 for 12 - 18 months. An EA with a validity of 10 years is recommended.

The Applicant must be bound to stringent conditions to maintain compliance and a responsible execution of the project.

In order to achieve appropriate environmental management standards and ensure that the findings of the environmental studies are implemented through practical measures, the recommendations from this BA study are included within the EMPr (**Appendix E**). The EMPr must be used to ensure compliance with environmental specifications and management measures.

The implementation of the EMPr for the construction phase of the project is considered to be vital in achieving the appropriate environmental management standards as detailed for this project.

In addition, the following key conditions should be included as part of the authorisation:

- a) The Developer is not negated from complying with any other statutory requirements that is applicable to the undertaking of the activity. Relevant key legislation that must be complied with by the proponent includes *inter alia*:
 - i. Provisions of the National Environmental Management Waste Act (Act No. 59 of 2008) (as amended);
 - ii. Provisions of the National Water Act, 1998 (Act No. 36 of 1998) (as amended); and
 - iii. National Heritage Resources Act (Act No. 25 of 1999).
- b) The Developer must appoint a suitably experienced (independent) Environmental Control Officer (ECO) for the construction phase of the development that will have the responsibility to ensure that

- the mitigation/ rehabilitation measures and recommendations are implemented and to ensure compliance with the provisions of the EMPr.
- c) All other necessary permits, licences and approvals must be obtained prior to the commencement of construction.
 - d) Prior to site clearance, a detailed 'walkthrough' must be conducted of the proposed site to ascertain the number, abundance and physical conditions of all protected tree species to assist with permit applications (DFFE).
 - e) Prior to site clearance, a detailed 'walkthrough' must be conducted of the proposed site to ascertain the number, abundance and physical conditions of all protected plant to assist with permit applications (NCDENC).
 - f) A construction and operational phase bird monitoring programme must be implemented by a bird specialist, to document potential impacts on key species such as korhaans, bustards and eagles, and must include the ongoing monitoring of the active Verreaux's Eagle and Martial Eagle nest sites.
 - g) Should archaeological sites or graves be exposed in other areas during construction work, it must immediately be reported to a heritage practitioner so that an investigation and evaluation of the finds can be made.
 - h) Noise mitigation requires engineering input from a qualified acoustic consultant. Further to this annual noise measurements programme is recommended.
 - i) From an air quality perspective:
 - i. As far as is practical, the reliability tests should be conducted when seasonal conditions allow the best pollutant dispersal (August to November).
 - ii. The start-and-stop preventative maintenance operation of the generators occurs during day-time hours only, ideally between 10:00 and 14:00.
 - iii. Emissions be monitored annually as per good operating practice.
 - iv. Monitoring at the nearest receptor to be conducted during the reliability tests.
 - v. The Developer will be required to align GHG reporting with National Policy.
 - vi. Greenhouse gas emissions must be reported annually via the South African Greenhouse Gas Emission Reporting System.

8.6.2 Recommendations to the Applicant

The Applicant must adhere to the recommendations provided by the specialists and the EAP. The EMPr summarises these recommendations. The Applicant must take full responsibility for the execution of the project in a manner which does not negatively impact on the environment by ensuring that responsible decisions are made.

8.7 Declaration by the EAPs

The following is hereby affirmed by the EAPs to be included in this report:

- the correctness of the information provided in the reports;
- the inclusion of all comments and inputs from stakeholders and I&APs;
- the inclusion of all inputs and recommendations from the specialist reports where relevant; and
- any information provided by the EAPs to I&APs and any responses by the EAPs to comments or inputs made by interested and affected parties.

Signed: Prashika Reddy (*Pr Sci Nat, EAPSA*)

Signed: Seshni Govender (*Pr Sci Nat*)

Signed: Malcolm Roods (*EAPASA*)



Regional Office Locations

With its headquarters in Amersfoort, The Netherlands, Royal HaskoningDHV is an independent, international project management, engineering and consultancy service provider. Ranking globally in the top 10 of independently owned, nonlisted companies and top 40 overall, the Company's 6,500 staff provide services across the world from more than 100 offices in over 35 countries.

Our connections

Innovation is a collaborative process, which is why Royal HaskoningDHV works in association with clients, project partners, universities, government agencies, NGOs and many other organisations to develop and introduce new ways of living and working to enhance society together, now and in the future.

Memberships

Royal HaskoningDHV is a member of the recognised engineering and environmental bodies in those countries where it has a permanent office base.

All Royal HaskoningDHV consultants, architects and engineers are members of their individual branch organisations in their various countries.