

NOTES

- GENERAL
- G 1. ALL DRAWINGS SHALL BE READ IN CONJUNCTION WITH THE RELEVANT ARCHITECTURAL AND OTHER CONSULTANTS DRAWINGS AND SPECIFICATIONS AND WITH SUCH OTHER WRITTEN INSTRUCTIONS AS MAY BE ISSUED DURING THE COURSE OF THE CONTRACT. ALL DISCREPANCIES SHALL BE REFERRED TO THE ENGINEER FOR A DECISION BEFORE PROCEEDING WITH THE WORK.
- G 2. ALL DIMENSIONS RELEVANT TO SETTING OUT AND OFF - SITE WORK SHALL BE VERIFIED BY THE CONTRACTOR BEFORE CONSTRUCTION AND FABRICATION IS COMMENCED. THE ENGINEER'S DRAWINGS SHALL NOT BE SCALED.
- G 3. THE CONTRACTOR SHALL BE RESPONSIBLE FOR MAINTAINING THE STRUCTURE IN A STABLE CONDITION AND ENSURING THAT NO PART IS OVERSTRESSED UNDER CONSTRUCTION ACTIVITIES.
- G 4. WORKMANSHIP AND MATERIALS ARE TO BE IN ACCORDANCE WITH THE RELEVANT S.A.B.S. STANDARDIZED SPECIFICATIONS INCLUDING ALL AMENDMENTS AND THE LOCAL STATUTORY AUTHORITIES EXCEPT WHERE VARYED BY THE CONTRACT DOCUMENTS.
- G 5. THE APPROVAL OF A SUBSTITUTION FOR A PRODUCT SPECIFIED SHALL BE OBTAINED FROM THE ENGINEER.

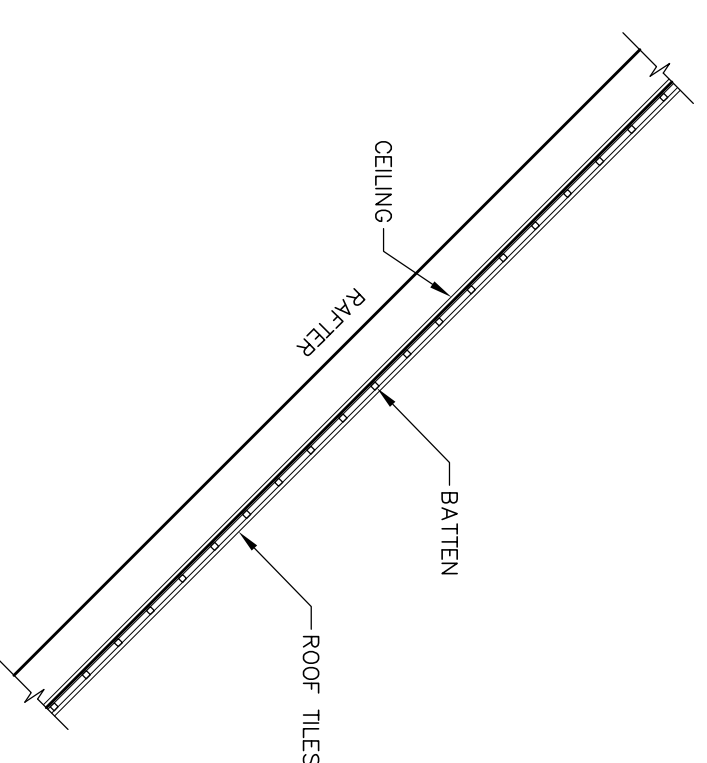
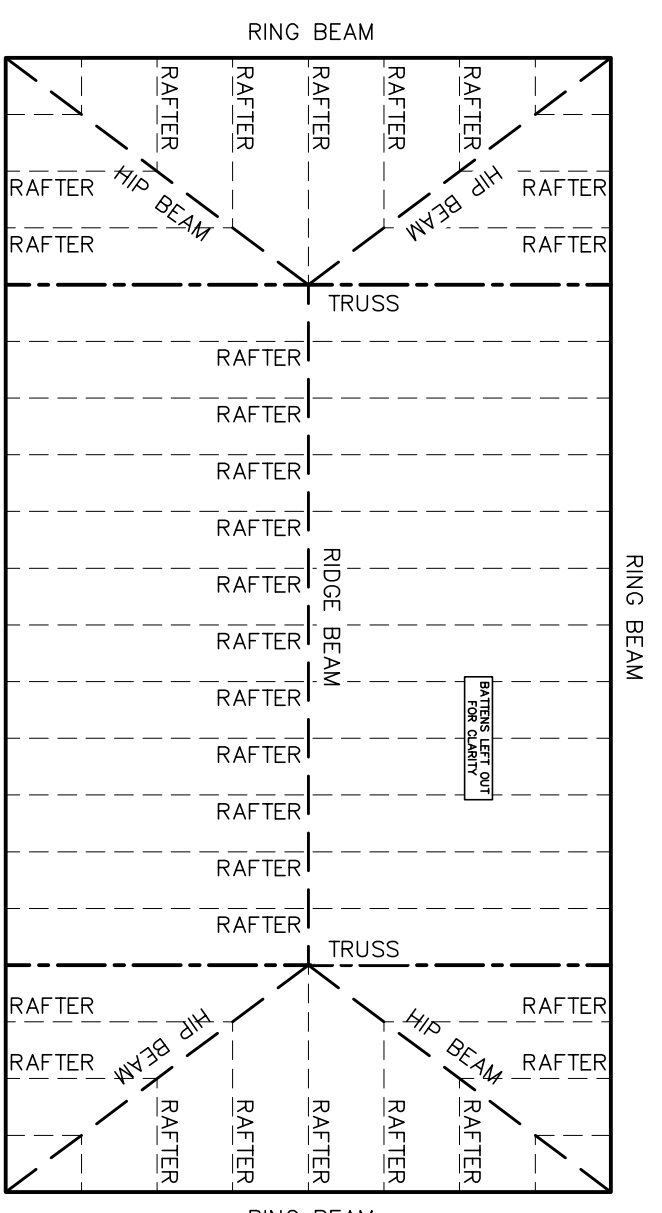
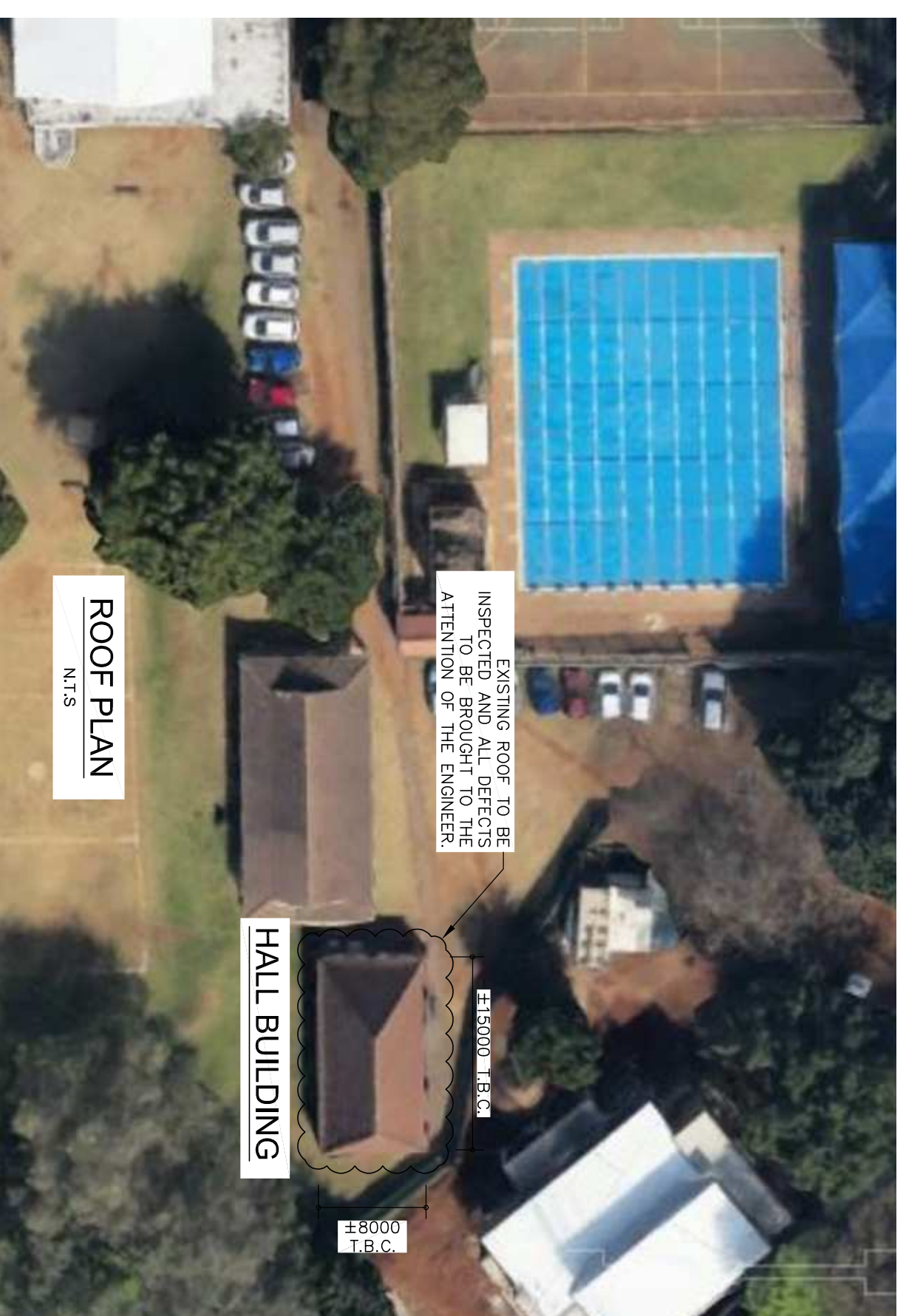

- NOTES:**
1. TIMBER SHALL BE AT LEAST A STRUCTURAL GRADE 9 AND HAVE A MOISTURE CONTENT OF LESS THAN 17% WHEN DELIVERED TO SITE.
 2. STRUCTURAL TIMBER TO BE GRADE 5 S.A.P. UNLESS OTHERWISE NOTED.
 3. TIMBER SIZES INDICATED ARE NOMINAL DIMENSIONS.
 4. ALL TIMBER TO BE PRESERVATIVE TREATED TO A MINIMUM H3 CLASSIFICATION IN ACCORDANCE WITH SANS 10005.
 5. ALL FASTENERS, NUTS AND BOLTS TO BE HOT DIPPED GALVANIZED.
 6. TRUSSES/RAFTERS SHALL BE PLUMB AND STRAIGHT BEFORE BATTENS AND BRACING IS ATTACHED.
 7. BATTENS SHALL BE CONTINUOUS OVER AT LEAST THREE RAFTERS (i.e. two rafter spaces) AND SHALL BE FIXED TO EVERY RAFTER THAT THEY CROSS. BATTENS OF SIZE 38mm X 38mm SHALL BE NAILED TO THE RAFTERS WITH 75mm WIRE NAILS AND 38mm X 50mm BATTENS SHALL BE SET OUT ON EDGE WITH 90mm WIRE NAILS, WHERE REQUIRED DUE TO ACCESS CONSTRAINTS. SPLICE PLATES/TIMBER CAN BE USED.
 8. JOINTS IN BATTENS SHALL BE ARRANGED SO THAT NO MORE THAN ONE BATTEN IN THREE IS JOINED ON ANY ONE RAFTER OR TRUSS. JOINTS IN BATTENS SHALL NOT BE WITHIN 1.5m OF GABLE ENDS.
 9. ALL DAMAGED BATTENS TO BE REPLACED AND WHERE REQUIRED NEW UNDERLAY TO BE INSTALLED.
 10. DAMAGED ROOF TILES TO BE REPLACED AND TO MATCH EXISTING WHERE POSSIBLE.
 11. ALL DEFECTS TO BE BROUGHT TO THE ATTENTION OF THE ENGINEER, WHERE REQUIRED. ADDITIONAL DETAILS WILL BE PROVIDED FOR DEFECTS IDENTIFIED.
 12. ALL EXISTING ROOF DIMENSIONS, ANGLES AND FRAMING ELEMENTS SIZES TO BE CONFIRMED BY THE CONTRACTOR.

PRELIMINARY DRAWING

PROJECT TITLE: GORDON GIRLS SCHOOL HALL BUILDING		JOB NUMBER: 1045	
DRAWING TITLE: ROOF PLAN & DETAILS TIMBER BATTENS REPLACEMENT		DRAWING NUMBER: 1045-100-002	
DRAWING NUMBER: 1045-100-002		REVISION: -	
<p>314-317 Mangrove Office Towers 115 Mangrove Road Durban 4091 T: Telephone 031-201 2403 C: 083-778 6788</p>			
DESIGNED	R.M./A.I	CHECKED	A. Ibrahim
DRAWN	R.Meza	SCALE	AS SHOWN
DATE	09/06/2021		