

Appendix G.8

NOISE IMPACT ASSESSMENT



Igolide Wind (Pty) Ltd

NOISE REPORT

FOR SCOPING PURPOSES

for the

proposed Igolide Wind Energy Facility and associated Infrastructure north-east of Fochville, Gauteng Province



Study done for:



Prepared by:



P.O. Box 2047, Garsfontein East, 0060
Tel: 012 – 004 0362, Fax: 086 – 621 0292, E-mail: info@eares.co.za

This Report should be sited as:

De Jager, M. 2023: "Noise Report for Scoping Purposes for the proposed Igolide Wind Energy Facility and associated Infrastructure north-east of Fochville, Gauteng Province".
Enviro-Acoustic Research, Pretoria

Client:

WSP SA for
Igolide Wind (Pty) Ltd

WSP House,
Building C
Knightsbridge
33 Sloane Street
Bryanston
2191

Report no:

WSP-EIWWEF/SNR/202306-Rev 0

Author:

M. de Jager (B. Ing (Chem))

Review:

Johan Maré (MSc. Microbiology, Pri Sci Nat (400092/91))

Date:

June 2023

COPYRIGHT WARNING

This information is privileged and confidential in nature and unauthorized dissemination or copying is prohibited. This information will be updated as required. Igolide Wind (Pty) Ltd claims protection of this information in terms of the Promotion of Access to Information Act, (No 2 of 2002) and without limiting this claim, especially the protection afforded by Chapter 4.

The document is the property of Enviro Acoustic Research cc. The content, including format, manner of presentation, ideas, technical procedure, technique and any attached appendices are subject to copyright in terms of the Copyright Act 98 of 1978 (as amended by the respective Copyright Amendment Acts No. 56 of 1980, No. 66 of 1983, No. 52 of 1984, No. 39 of 1986, No. 13 of 1988, No. 61 of 1989, No. 125 of 1992, Intellectual Property Laws Amendment Act, No. 38 of 1997 and, No. 9 of 2002) in terms of section 6 of the aforesaid Act, and may only be reproduced as part of the Environmental Impact Assessment process by WSP SA.

EXECUTIVE SUMMARY

INTRODUCTION AND PURPOSE

Enviro-Acoustic Research cc was commissioned by Igolide Wind (Pty) Ltd (the project applicant) to undertake a specialist study to determine the potential noise impact on the surrounding environment due to the establishment of the proposed Igolide Wind Energy Facility ("WEF") north-east of Fochville, Gauteng.

This report is the result of the initial phase study (desktop) of the Environmental Impact Assessment ("EIA") process investigating the potential noise impact that such a facility may have on the surrounding environment, highlighting methodologies, potential issues to be investigated as well as preliminary findings and recommendations.

This scoping noise report considered local and international guidelines, using the terms of reference ("ToR") as proposed by SANS 10328:2008 and as proposed by the requirements specified in the Assessment Protocol for Noise that were published on 20 March 2020, in Government Gazette 43110, GN 320.

PROJECT DESCRIPTION

The project applicant is proposing the development of a commercial WEF and associated infrastructure on a site located just north-east of Fochville. The proposed Igolide WEF and associated infrastructure includes the following components:

- Up to 12 wind turbine generators ("WTGs") to allow for a maximum capacity of up to 100 MW for the WEF, each with a hub height of up to 200 m and a rotor diameter of up to 200 m;
- Temporary laydown, hardstands and storage areas;
- Temporary construction camps and batching plants;
- Medium voltage cabling connecting the WTGs;
- A Battery Energy Storage System ("BESS");
- Internal roads;
- A 33/32kV on-site IPP substation;
- Operation and maintenance ("O&M") buildings;
- Access and internal roads; and
- Supporting infrastructure.

DESCRIPTION OF STUDY AREA

The proposed WEF will be located in the Merafong City Local Municipality (West Rand District – Gauteng Province). The study area is further described in terms of environmental

components that may contribute to or change the sound character in the area. The topography can be described as hills and lowlands with plains in the north, though topography will not influence the propagation of noise from the project. Land use within the Project Focus Area ("PFA") is a combination of recreational, wilderness, some dryland crops and animal husbandry. There are two roads transecting the PFA, with a number of gold mines to the north and east of the PFA.

DESCRIPTION OF AMBIENT SOUND LEVELS

Ambient sound levels were measured over a 6-night period from 3 to 9 May 2023 at four locations, resulting in more than 2,000 daytime and 1,000 night-time measurements. Each measurement was collected over a 10-minute period and included a number of sound level descriptors, including; equivalent values, minimum and maximum levels, statistical sound levels as well as spectral information. Confidence levels in the resulting data are high and it is expected that the ambient sound level data would be applicable of other locations in the area.

Bird communication noises were significant and generally dominant, with road traffic noises audible at all the measurement locations. Road traffic noises were dominant at the first measurement location (approximately 300m from the N12 road).

Considering the average fast-weighted sound level data collected in the area:

- daytime fast-weighted sound levels ranged from 27 to more than 70 dBA, with average daytime sound levels being 48.2 dBA. This is typical of a rural to sub-urban noise district and, considering the developmental character, a rating level of 50 dBA (typical of a suburban noise district) will be assumed for the daytime period; and
- night-time fast-weighted sound levels ranged from 31 to more than 60 dBA, with average night-time sound levels being 44.4 dBA. This is higher than the noise levels expected for a rural to suburban district (based on the developmental character). While this residual noise level is more typical of an urban noise district, this assessment will consider a rating level of:
 - 40 dBA (typical of a sub-urban noise district) at locations further than 1,000m from the N12 or R500 roads; and
 - 45 dBA (typical of an urban noise district) at locations closer than 1,000m from the N12 or R500 roads.

FINDINGS AND RECOMMENDATIONS

This assessment is based on a desktop assessment as well as a basic predictive model to identify potential issues of concern. Wind turbines do emit noises at sufficient levels to propagate over large distances and this assessment indicates a potential noise impact on the closest receptors.

Considering the preliminary wind turbine layout, there is a potential of a **low to medium** significance of a noise impact during the construction phase, and of a **low to high** significance during the operational phase on the different identified NSR. Mitigation measures will be identified and recommended during the future environmental noise impact assessment that should reduce the noise impact to a low significance.

Further study is required and it is recommended that a full Environmental Noise Impact Assessment study be conducted for the Igolide WEF.



Signature

Morné de Jager

2023 – 06 – 20

TABLE OF CONTENTS

	Page
EXECUTIVE SUMMARY	i
TABLE OF CONTENTS	v
LIST OF TABLES.....	vii
LIST OF FIGURES.....	viii
APPENDICES.....	viii
1 INTRODUCTION	1
1.1 Introduction and Purpose	1
1.2 Brief Project Description	1
1.3 Potential Noise Sources	2
1.4 Study area	3
1.4.1 Topography	3
1.4.2 Roads and rail roads	3
1.4.3 Land use and unrelated noise sources	3
1.4.4 Residential areas.....	4
1.4.5 Ground conditions and vegetation.....	4
1.4.6 Existing Ambient Sound Levels.....	4
1.4.7 Desired Rating Levels.....	5
1.5 Noise-sensitive Receptors or Developments	5
1.6 Comments received during the EIA.....	6
1.7 Potential Project Alternatives	6
1.8 Environmental Sensitivity – Noise Theme.....	7
1.9 Legislative Requirements and Terms of Reference	7
1.9.1 Requirements as per GG 43110 (GNR 320 of March 2020).....	7
1.9.2 Requirements as per South African National Standards	8
2 POLICIES AND THE LEGAL CONTEXT	13
2.1 The Republic of South Africa Constitution Act (“the Constitution”)... 13	
2.2 The National Environmental Management Act, 1998 (Act 107 of 1998)	13
2.3 The Environment Conservation Act, 1989 (Act 73 of 1989).....	14
2.3.1 Noise Control Regulations (GN R154 of 1992)	14

2.3.2	<i>Noise Control Regulations: Gauteng Province (GN 5479 of 20 August 1999)</i>	14
2.4	International Guidelines	16
2.4.1	<i>Guidelines for Community Noise (World Health Organization, 1999)</i>	16
2.4.2	<i>The Assessment and Rating of Noise from Wind Farms (Energy Technology Support Unit, 1997)</i>	17
2.4.3	<i>Noise Guidelines for Wind Farms (MoE, 2008)</i>	18
2.4.4	<i>Equator Principles</i>	18
2.4.5	<i>IFC: General EHS Guidelines – Environmental Noise Management (IFC, 2007)</i>	19
2.4.6	<i>Environmental, Health, and Safety Guidelines for Wind Energy (WBG, 2015) [36]</i>	20
2.4.7	<i>Environmental Noise Guidelines for the European Region (WHO, 2018) [38]</i>	21
3	POTENTIAL NOISE SOURCES	23
3.1	Potential Noise Sources: Construction Phase	23
3.1.1	<i>Construction equipment</i>	23
3.1.2	<i>Blasting</i>	27
3.1.3	<i>Traffic</i>	27
3.2	Potential Noise Sources: Operation Phase	28
3.2.1	<i>Wind Turbine Noise: Aerodynamic sources</i>	28
3.2.2	<i>Wind Turbine: Mechanical sources</i>	29
3.2.3	<i>Low Frequency Noise</i>	30
3.2.4	<i>Amplitude modulation</i>	31
3.2.5	<i>Battery Energy Storage Systems</i>	32
3.2.6	<i>Transformer noises (Substations)</i>	33
3.2.7	<i>Transmission Line Noise (Corona noise)</i>	33
4	METHODOLOGY: NOISE SPECIALIST ASSESSMENT	35
4.1	Noise Impact on Animals	35
4.2	Why noise concerns communities	36
4.2.1	<i>Annoyance associated with Wind Energy Facilities</i>	36
4.3	Impact Assessment Criteria	38
4.3.1	<i>Overview: The common characteristics</i>	38
4.3.2	<i>Noise criteria of concern</i>	38
4.3.3	<i>Determining appropriate Zone Sound Levels</i>	40
4.4	Determining the Scoping Significance of the Noise Impact	43

4.5	Determining the EIA Significance of the Noise Impact.....	45
5	RESULTS AND PRELIMINARY IMPACT ASSESSMENT	46
5.1	Construction Phase	46
5.2	Operational Phase: Estimated Impact and Important Concepts.....	46
6	PRELIMINARY SIGNIFICANCE OF THE NOISE IMPACT ...	48
6.1	Construction Phase Noise Impact	48
6.2	Operational Phase Noise Impact.....	49
7	CONCLUSIONS AND RECOMMENDATIONS	50
8	TERMS OF REFERENCE FOR THE ENVIRONMENTAL NOISE IMPACT PHASE	51
8.1	Purpose of the Environmental Noise Impact Assessment	51
8.2	Plan of study for environmental noise impact investigation and assessment	51
8.3	Environmental noise impact investigation	51
8.3.1	<i>Sound emission from the identified noise sources</i>	<i>51</i>
8.3.2	<i>Determination of Rating levels</i>	<i>52</i>
8.3.3	<i>Assessment of the noise impact: No mitigation</i>	<i>52</i>
8.3.4	<i>Assessment of the noise impact: With Implementation of Mitigation</i>	<i>53</i>
8.4	Environmental Noise Impact Report.....	53
9	REFERENCES	55

LIST OF TABLES

	page
Table 1-1: Checklist - Plan of Study for Scoping (SANS 10328:2008)	9
Table 2-1: Summary of Sound Level Limits for Wind Farms (MoE).....	18
Table 2-2: IFC Table 7.1-Noise Level Guidelines	20
Table 3-1: Potential maximum noise levels generated by construction equipment	25
Table 3-2: Potential equivalent noise levels generated by various equipment.....	26
Table 4-1: Acceptable Zone Sound Levels for noise in districts (SANS 10103).....	40
Table 4-2: Probability Scores and Descriptors	43
Table 4-3: Consequence Score Descriptions.....	44

Table 4-4: Significance Screening Tool	44
Table 4-5: Impact Significance Colour Reference System to Indicate the Nature of the Impact	45
Table 6-1: Scoping Level Noise Impact Assessment: Construction Activities	48
Table 6-2: Impact Assessment: Operational Activities	49

LIST OF FIGURES

	page
Figure 1-1: Regional Location of the proposed Igolide WEF	10
Figure 1-2: Aerial Image indicating closest identified Noise-sensitive developments	11
Figure 1-3: Aerial Image indicating output of the online screening tool	12
Figure 3-1: Noise Emissions Curve of a number of different wind turbines (figure for illustration purposes only)	29
Figure 3-2: Conceptual BESS components	33
Figure 4-1: Percentage of annoyed persons as a function of the day-evening-night noise exposure at the façade of a dwelling	37
Figure 4-2: Criteria to assess the significance of impacts stemming from noise	39
Figure 4-3: Ambient sound levels – quiet inland location (A-Weighted)	43
Figure 5-1: Extent of noises from different wind turbines (unmitigated, worst-case parameters)	47

APPENDICES

Appendix A	Curriculum Vitae
Appendix B	Glossary of Terms
Appendix C	Site Sensitivity Verification

ABBREVIATIONS

ADT	Articulated Dump Trucks
ASTER	Advanced Spaceborne Thermal Emission and Reflection Radiometer
BA	Basic Assessment

BESS	Battery Energy Storage System
dB/dBA	Decibel
DFFE	Department of Forestry, Fisheries and Environment
EARES	Enviro Acoustic Research cc
ECA	Environment Conservation Act
ECO	Environmental Control Officer
EIA	Environmental Impact Assessment
EHS	Environmental Health and Safety
ENIA	Environmental Noise Impact Assessment
ENM	Environmental Noise Monitoring
ENPAT	Environmental Potential Atlas for South Africa
ETSU	Energy Technology Support Unit
EPs	Equator Principles
EPC	Engineering, Procurement and Construction
EPFIs	Equator Principles Financial Institutions
FEL	Front-end Loader
GN	Government Notice
GNR	Government Notice Regulation
HNI	House Not Inhabited
I&APs	Interested and Affected Parties
IEC	International Electrotechnical Commission
IFC	International Finance Corporation
ISO	International Organization for Standardization
METI	Ministry of Economy, Trade, and Industry
NA	No Access
NASA	National Aeronautical and Space Administration
NEMA	National Environmental Management Act
NCR	Noise Control Regulations
NSD	Noise-sensitive Development
NSR	Noise-sensitive Receptors
PPP	Public Participation Process
PWL	Sound Power Level
SABS	South African Bureau of Standards
SANS	South African National Standards
SPL	Sound Power Level
SR	Significance Rating
TLB	Tip load bucket (also referred to as a back-actor or backhoe)
UTM	Universal Transverse Mercator

WHO World Health Organization
WF Wind Farm
WIN Wind Induced Noises

GLOSSARY OF UNITS

dB	Decibel (expression of the relative loudness of the un-weighted sound level in air)
dBA	Decibel (expression of the relative loudness of the A-weighted sound level in air)
Hz	Hertz (measurement of frequency)
kg/m ²	Surface density (measurement of surface density)
km	kilometre (measurement of distance)
m	Meter (measurement of distance)
m ²	Square meter (measurement of area)
m ³	Cubic meter (measurement of volume)
mamsl	Meters above mean sea level
m/s	Meter per second (measurement for velocity)
°C	Degrees Celsius (measurement of temperature)
μPa	Micro pascal (measurement of pressure – in air in this document)

1 INTRODUCTION

1.1 INTRODUCTION AND PURPOSE

Enviro-Acoustic Research cc was commissioned by Igolide Wind (Pty) Ltd (the applicant) to undertake a specialist study to determine the potential noise impact on the surrounding environment due to the proposed establishment of the proposed Igolide Wind Energy Facility (“WEF”) north-east of Fochville, Gauteng.).

This report is the result of the initial phase study (desktop) of the Environmental Impact Assessment (“EIA”) process investigating the potential noise impact that such a facility may have on the surrounding environment, highlighting methodologies, potential issues to be investigated as well as preliminary findings and recommendations. The Environmental Impact Assessment process will be facilitated by WSP, the appointed Environmental Assessment Practitioner (EAP) for this project.

It is important to note this document is only the Scoping Document. While a preliminary layout was available, this report presents conceptual scenarios to illustrate important concepts. A detailed assessment will be undertaken in the future Environmental Noise Impact Assessment.

1.2 BRIEF PROJECT DESCRIPTION

The project applicant is proposing the development of a commercial WEF and associated infrastructure on a site located just north-east of Fochville, Gauteng (see **Figure 1-1**). The proposed Igolide WEF and associated infrastructure include the following components:

- Up to 12 wind turbine generators (“WTGs”) to allow for a maximum capacity of up to 100 MW for the WEF;
- The WTG to have a hub height of up to 200 m and a rotor diameter of up to 200 m;
- Temporary laydown, hardstands and storage areas;
- Temporary construction camps and batching plants;
- Medium voltage cabling connecting the WTGs;
- A Battery Energy Storage System (“BESS”) comprising of several utility scale battery modules within shipping containers or an applicable housing structure with a storage capacity of up to 100MW/400MWh. Lithium-Ion Phosphate, Lithium Nickel Manganese Cobalt oxides or Vanadium Redox flow technologies will be considered as the preferred battery technology, however, the specific technology will only be determined following Engineering, Procurement and Construction (“EPC”);
- Internal roads with a width of 8 – 10m providing access to each turbine the BESS, on-site substation (“SS”), step-down substation and laydown area, increasing up to

15m for turning circle/bypass areas to allow for larger component transport. The roads will accommodate cable trenches and stormwater channels (as required). As such, the roads and cables will be positioned within a 20 m wide corridor. Existing roads will be upgraded wherever possible, although new roads will be constructed where necessary;

- A 33/132kV on-site IPP substation;
- Medium voltage collector system will comprise cables up to and including 33kV that run underground, except where a technical assessment suggests that overhead lines are required, connecting the turbines to the on-site IPP;
- Operation and maintenance ("O&M") buildings; and
- Supporting infrastructure.

1.3 POTENTIAL NOISE SOURCES

The main noise source from this project would be the WTGs (**sections 3.2.1** and **3.2.2**) during the operational phase, with noises from the BESS (climate control system – see **section 3.2.5**) and the substation (see **section 3.2.6**). WTG noises however would be the dominant source of noise associated with the project.

The sound power emission levels ("SPL") of the WTG are normally provided by the manufacturer, either as the apparent SPL, maximum warranted SPL, a calculated SPL (for new WTG where the noise levels were not previously measured) or measured sound power levels as reported in terms of IEC 61400-11 or IEC 61400-14. It is unique for each make and model and the sound power levels already include the effect of the hub height, rotor diameter and abatement technologies.

Minor factors in the noise levels are:

- The spectral characteristics of the WTG;
- Temperature and Humidity;
- Noise abatement technologies implemented by the manufacturer;
- Topography and wind shear effects;
- The hub height of the WTG nacelle (the declared SPL level already include this factor, modelling using different hub height than the level specified by the manufacturer does have a slight influence on the calculated noise levels at a receptor location);
- Ground surface characteristics.

Factors that do influence SPL are:

- The rotor diameter of the WTG (the declared SPL level already include this factor);

- The manufacture of the WTG, the model name or number (the declared SPL level already include this factor).

1.4 STUDY AREA

The proposed WEF will be located in the Merafong City Local Municipality (West Rand District – Gauteng Province). The project focus area (“PFA”) is an area selected to enclose all potential project infrastructure up to 2,000 m from activities or equipment that may generate significant noise. The regional location of the PFA is illustrated in **Figure 1-1**. The PFA is further described in terms of environmental components that may contribute to or change the sound character in the area.

1.4.1 Topography

The topography can be described as hills and lowlands with plains to the north. Due to the height of the wind turbines, as well as the position where they may be developed, it is unlikely that topographical features will limit the propagation of sound from the wind turbines.

1.4.2 Roads and rail roads

The N12 transects that PFA in the north, with the R500 transecting the PFA in the south-west. Both these roads carry significant traffic day and night, and it is expected that road traffic noises will influence ambient sound levels up to 1,000m from these roads at times. Traffic noises may be audible up to 4,000m during quiet periods at night. There are also a number of small roads exiting from these roads, used by the local communities and farmers.

Noise from vehicular traffic will however not be considered in this Scoping, or the future Environmental Noise Impact Assessment (“ENIA”) reports as this is a variable noise source, it is limited to within 500 – 1,000m from the roads and the potential contribution of road traffic is included in the residual noise levels.

1.4.3 Land use and unrelated noise sources

Based on available aerial images, land use within the Project Focus Area (“PFA”) is recreational, wilderness, some dryland crops and animal husbandry. Residential structures are scattered in a heterogeneous manner within the PFA. Minor noise sources are associated with agricultural and typical household activities. Noise from these sources will not be investigated in this scoping, or the future environmental noise impact assessment (“ENIA”) as these are minor noise sources.

There are existing mining activities located to the north and east of the PFA and the ventilation fans may be audible over considerable distances (during quiet periods at night).

Noises from existing mining activities will however not be considered in this Scoping, or the future ENIA reports because noise sources are outside the PFA.

1.4.4 Residential areas

The town of Fochville is located to the south-west within and just outside the PFA.

1.4.5 Ground conditions and vegetation

Most of the area falls within the Grassland biome with the natural vegetation being described as rocky highveld grassland. Agriculture and other anthropogenic activities did impact on the ground surface, though most of the area is well covered by (seasonal) crops, grasses, sedges and shrubs. Medium (construction phase) to 75% hard (operational phase) ground surface conditions will be "used for modelling purposes in the future Environmental Noise Impact Assessment ("ENIA"). It should be noted that this factor is only relevant for air-borne waves being reflected from the ground surface, with certain frequencies slightly absorbed by the vegetation.

1.4.6 Existing Ambient Sound Levels

Ambient sound levels were measured over a 6-night period from 3 to 9 May 2023 at four locations, resulting in more than 2,000 daytime and 1,000 night-time measurements. Each measurement was collected over a 10-minute period and included a number of sound level descriptors, including; equivalent values, minimum and maximum levels, statistical sound levels as well as spectral information. Confidence levels in the resulting data are high and it is expected that the ambient sound level data would be applicable of other locations in the area.

Bird communication noises were significant and generally dominant, with road traffic noises audible at all the measurement locations. Road traffic noises were dominant at the first measurement location (approximately 300m from the N12 road).

Considering the average fast-weighted sound level data collected in the area:

- daytime fast-weighted sound levels ranged from 27 to more than 70 dBA, with average daytime sound levels being 48.2 dBA. This is typical of a rural to sub-urban noise district and, considering the developmental character, a rating level of 50 dBA (typical of a suburban noise district) will be assumed for the daytime period; and
- night-time fast-weighted sound levels ranged from 31 to more than 60 dBA, with average night-time sound levels being 44.4 dBA. This is higher than the noise levels expected for a rural to suburban district (based on the developmental character). While this residual noise level is more typical of an urban noise district, this assessment will consider a rating level of:

- 40 dBA (typical of a sub-urban noise district) at locations further than 1,000m from the N12 or R500 roads; and
- 45 dBA (typical of an urban noise district) at locations closer than 1,000m from the N12 or R500 roads.

1.4.7 Desired Rating Levels

The development of the WEF will result in changes in the ambient sound levels. Considering the result of the ambient sound level measurements, the fact that the WTG will only operate (and generate noise) during periods with increased winds as well as the noise limits recommended by the World Health Organization ("WHO" – see **section 2.4.1**) and the International Finance Corporation ("IFC" – see **section 2.4.5**), desired rating levels will be:

- 55 dBA for the daytime period; and
- 45 dBA for the night-time period.

1.5 NOISE-SENSITIVE RECEPTORS OR DEVELOPMENTS

Potential Noise-sensitive receptors ("NSR") were initially identified using aerial images as well as the Online Environmental Screening Tool. The status of the NSR was verified during a site visit in May 2023, with their locations highlighted in **Figure 1-2**. **Figure 1-3** illustrate areas identified by the National Web based Environmental Screening Tool¹ to have a "very high" sensitivity to noise.

Also indicated on this figure are generalized 500 m, 1,000 m and 2,000 m buffer zones. For a WTG with a sound power emission level less than 109 dBA (re 1 pW), noises:

- Could be significant within 500 m, with receptors² staying within 500 m from an operational WTG subject to noises at a potentially sufficient level to be considered disturbing;
- Are normally limited to a distance of approximately 1,000m from an operational WTG. Night-time ambient sound levels are elevated and the potential noise impact might be measurable. Cumulative noises from multiple WTG surrounding an NSR may be high and exceed 45 dBA;
- May be audible up to a distance of 2,000m at night; and
- Are generally of a low concern at distances greater than 2,000m.

¹ <https://screening.environment.gov.za/screeningtool/#/pages/welcome>

² Exact noise levels at a NSR would depend on the WTG layout as well as the specific sound power emission levels of the selected WTG.

It should be noted that each marker highlighted may represent a number of different dwellings that are, or could be used for residential activities. The status of these dwellings will only be confirmed during a future site visit.

1.6 COMMENTS RECEIVED DURING THE EIA

The author is not aware of any comments raised by the authorities or interested and affected parties at the date this noise scoping report was compiled. It should however be noted that the scoping phase is the start of the Public Participation Process ("PPP") as part of the EIA. Comments regarding noise may only be available during the EIA and PPP process.

1.7 POTENTIAL PROJECT ALTERNATIVES

The decision to develop the WEF at this location is the result of a number of feasibility studies, considering a number of factors, including (amongst others):

- the availability of a viable wind resource;
- the availability of land to develop the WEF;
- grid capacity and the viability to connect the WEF to the national grid or to supply the electrical power to an end-user (potential off-take agreement(s));
- topography and site access;
- land use and suitability;
- landowner support;
- Limited environmental constraints;
- viable alternative options (Photo-voltaic versus concentrated solar versus other power generation technologies).

As a WEF was selected as the most feasible option, secondary alternatives include (amongst others):

- the total electrical power generation capacity;
- the WTG layout of the WEF (with the scoping WTG layout being the result of a number of design iterations); and
- the type and size of the WTG (that will only be decided at a much later stage in the project).

1.8 ENVIRONMENTAL SENSITIVITY – NOISE THEME

The project site was assessed in terms of the Noise Sensitivity Theme using the National Web-based Environmental Screening Tool³. The output of the Screening Tool is presented on **Figure 1-3**, highlighting a number of areas identified to have a “very high” noise sensitivity. A site verification report will be completed after the site visit and included in the future Environmental Noise Impact Assessment (ENIA).

1.9 LEGISLATIVE REQUIREMENTS AND TERMS OF REFERENCE

A noise impact assessment must be conducted if the proposed development triggers the following:

- A change in land use as highlighted in SANS 10328:2008 (section 3.3 of the SANS guideline);
- If a wind farm (wind turbines - SANS 10328:2008 [5.4 (i)]) or a source of low-frequency noise (such as cooling or ventilation fans - SANS 10328:2008 [5.4 (l)]) is to be established within 2,000 m from a potential NSR *or visa versa*;
- It is generally required by the local or district authority as part of the environmental authorization or planning approval in terms of Regulation 2(d) or GN R154 of 1992;
- It is a controlled activity in terms of the NEMA EIA Regulations, 2014, as amended and an ENIA is required, because:
 - It may cause a disturbing noise that is prohibited in terms of section 18(1) of the Government Notice 579 of 2010;
 - It is an environmental theme to be further assessed as identified by the National Web-based Environmental Screening Tool as required by Government Gazette No. 42451 of 10 May 2019 (proposed procedures for noise assessments);

1.9.1 Requirements as per GG 43110 (GNR 320 of March 2020)

The Department of Forestry, Fisheries and Environment (DFFE) also promulgated Government Notice Regulation (GNR) 320, dated 20 March 2020 as published in Government Gazette No. 43110. The Procedures for the Assessment and Minimum Criteria for Reporting on Identified Environmental Themes in Terms of Sections 24(5)(a) and (h) and 44 of the National Environmental Management Act, 1998, when applying for Environmental Authorisation would be applicable to this project.

This regulation defines the requirements for undertaking a site sensitivity verification, specialist assessment and the minimum report content requirements for environmental

³ <https://screening.environment.gov.za/screeningtool/#/pages/welcome>

impact where a specialist assessment is required but no protocol has been prescribed. It requires that the current land use be considered using the national web based environmental screening tool to confirm the site sensitivity available at: <https://screening.environment.gov.za>.

If an applicant intending to undertake an activity identified in the scope of this protocol for which a specialist assessment has been identified on the screening tool on a site identified as being of:

- "very high" sensitivity for noise, must submit a Noise Specialist Assessment; or
- "low" sensitivity for noise, must submit a Noise Compliance Statement.

On a site where the information gathered from the site sensitivity verification differs from the designation of "very high" sensitivity on the screening tool and it is found to be of a "low" sensitivity, a Noise Compliance Statement must be submitted. On a site where the information gathered from the initial site sensitivity verification differs from the designation of "low" sensitivity on the screening tool and it is found to be of a "very high" sensitivity, a Noise Specialist Assessment must be submitted.

If any part of the proposed development footprint falls within an area of "very high" sensitivity, the assessment and reporting requirements prescribed for the "very high" sensitivity apply to the entire footprint excluding linear activities for which noise impacts are associated with construction activities only and the noise levels return to the current levels after the completion of construction activities, in which case a compliance statement applies. In the context of this protocol, development footprint means the area on which the proposed development will take place and includes any area that will be disturbed.

Considering the preliminary layout, the potential areas identified to have a "very high" sensitivity to noise and the identified noise-sensitive receptors, a noise specialist assessment will be completed as an ENIA. The minimum requirements for an ENIA are also covered in **Section 8.4**.

1.9.2 Requirements as per South African National Standards

In South Africa the document that addresses the issues specifically concerning environmental noise is SANS 10103:2008. It has been revised extensively in 2008 and brought in line with the guidelines of the World Health Organization (WHO). It provides the maximum average ambient noise levels during the day and night to which different types of developments may be exposed indoors.

The SANS 10328:2008 specifies the methodology to assess the potential noise impacts on the environment due to a proposed activity that might impact on the environment. This standard also stipulates the minimum requirements to be investigated for Scoping purposes. It stipulates the need for a Plan of Study for Scoping (clause 7.2 of SANS 10328:2008), highlighted in Table 1-1 below

Table 1-1: Checklist - Plan of Study for Scoping (SANS 10328:2008)

Checklist as per SANS 10328:2008 (clause 7.2)	Section
identification and description of the noise sources associated with the development that has to be investigated	1.3
identification and description of noise-sensitive developments associated with the development that has to be investigated	1.5
identification and description of the noise sources and noise-sensitive developments in the target area that could affect the development (or that could be affected by the development) that has to be investigated	1.4.2 1.4.3
identification, with the assistance of all interested or affected parties, and description of all the noise sources and noise-sensitive developments associated with the development, or located within the target area, that are to be excluded from the investigation. The reason(s) for the exclusion shall be stated	1.4.2 1.4.3

In addition, the Scoping report should contain sufficient information to allow the EAP to compile the Plan of Study for future EIA, including the Noise component.

In this regard the following will be included to assist the EAP in the compilation of the Plan of Study (PoS) for the EIA, discussed in general in **section 8** and defined in **section 8.2**.

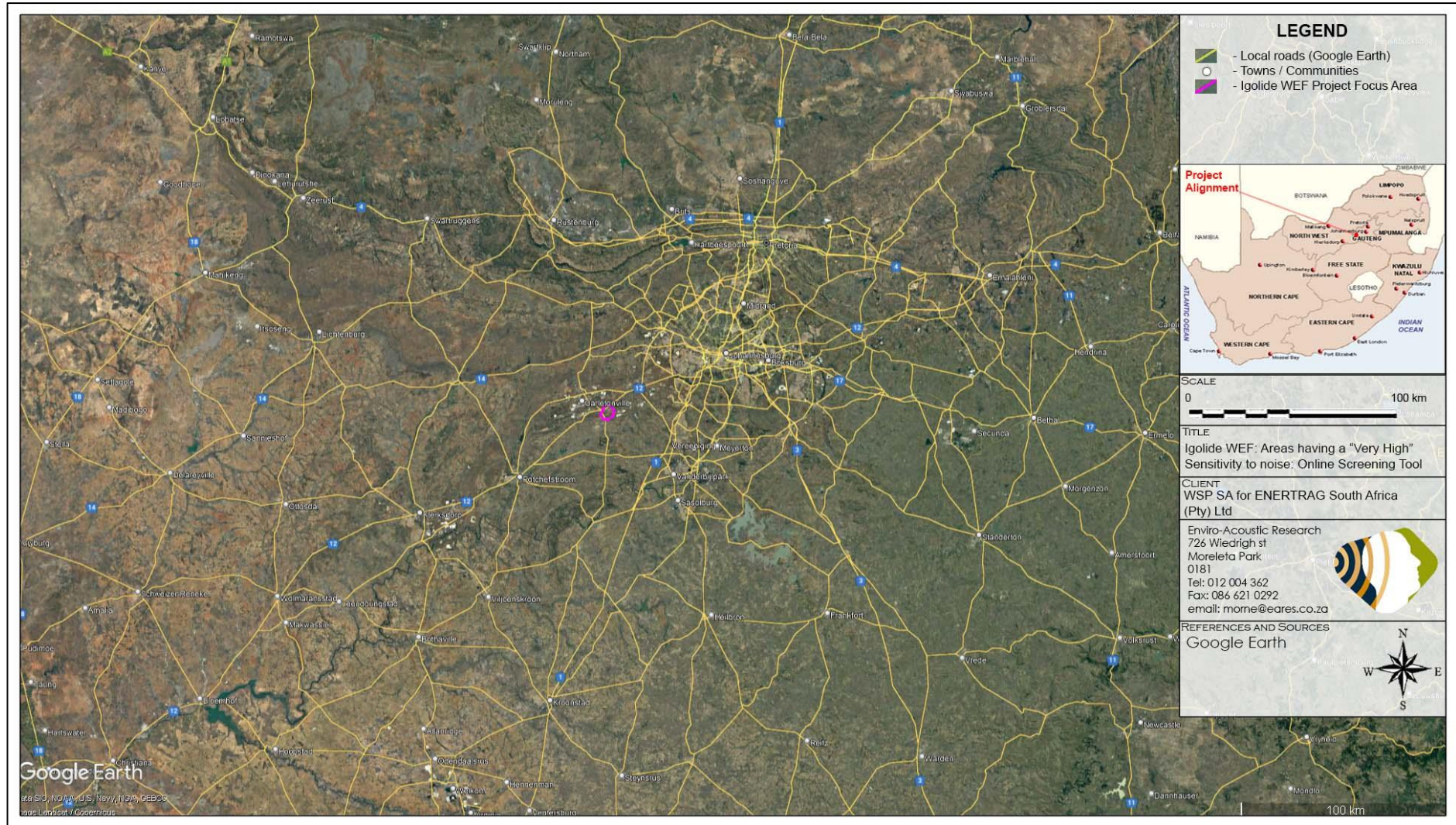

Figure 1-1: Regional Location of the proposed Igoide WEF

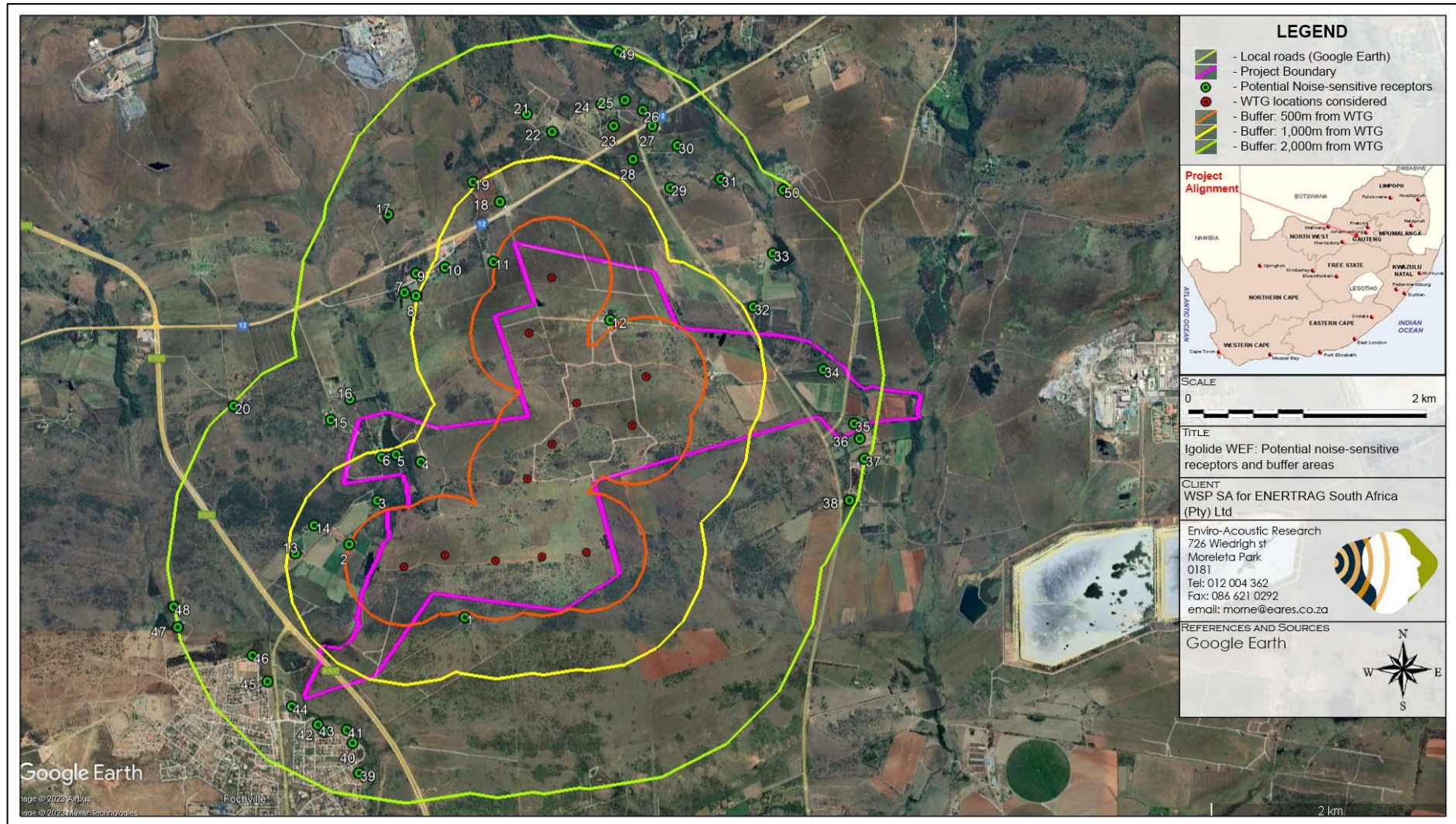

Figure 1-2: Aerial Image indicating closest identified Noise-sensitive developments



Figure 1-3: Aerial Image indicating output of the online screening tool

2 POLICIES AND THE LEGAL CONTEXT

2.1 THE REPUBLIC OF SOUTH AFRICA CONSTITUTION ACT (“THE CONSTITUTION”)

The environmental right contained in section 24 of the Constitution provides that everyone is entitled to an environment that is not harmful to his or her well-being. In the context of noise, this requires a determination of what level of noise is harmful to the well-being of humans. The general approach of the common law is to define an acceptable level of noise as that which the reasonable person can be expected to tolerate in the particular circumstances. The subjectivity of this approach can be problematic; however, this has led to the development of noise standards (see **Sections 2.3.1 and 2.3.2**).

“Noise pollution” is specifically included in Part B of Schedule 5 of the Constitution, which means that noise pollution control is a local authority competence, provided that the local authority concerned has the capacity to carry out this function.

2.2 THE NATIONAL ENVIRONMENTAL MANAGEMENT ACT, 1998 (ACT 107 OF 1998)

The National Environmental Management Act, 1998 (Act 107 of 1998), as amended (“NEMA”) defines “pollution” to include any change in the environment, including noise. A duty therefore arises under section 28 of NEMA to take reasonable measures while establishing and operating any facility to prevent noise pollution occurring. NEMA sets out measures, which may be regarded as reasonable. They include the following measures to:

1. investigate, assess and evaluate the impact on the environment;
2. inform and educate employees about the environmental risks of their work and the manner in which their tasks must be performed to avoid causing significant pollution or degradation of the environment;
3. cease, modify or control any act, activity or process causing the pollution or degradation;
4. contain or prevent the movement of the pollution or degradation;
5. eliminate any source of the pollution or degradation; and
6. remedy the effects of the pollution or degradation.

Regulations have been promulgated in GN R982, R983, R984 and R985 in GG 38282, dated 4 December 2014, which came into effect on 8 December 2014. These were amended in April 2017, specifically promulgated in GN R326, R327, R325 and R324 in GG 40772, dated 7 April 2017.

Furthermore, Protocols were published in Government Gazette 43110 / GNR 320 on 20 March 2020 for specific environmental themes, including noise. “Requirements for the assessment

and minimum criteria for reporting on identified environmental themes in terms of sections 24(5)(a) and (h) and 44 of the National Environmental Management Act, 1998, when applying for Environmental Authorisation". These Protocols prescribe the general requirements for undertaking site sensitivity verification and the level of specialist assessment required as well as the assessment reporting requirements per environmental theme. The requirements of the Noise Protocol for the undertaking of a Noise Specialist Assessment have been adhered to. The national web-based Environmental Screening Tool identified the site to be of high noise sensitivity and therefore full Noise Specialist Assessment has been undertaken.

When the requirements of a protocol apply, the requirements of Appendix 6 of the Environmental Impact Assessment Regulations, as amended, (EIA Regulations), promulgated under sections 24(5) and 44 of the National Environmental Management Act, 1998 (Act No. 107 of 1998), are replaced by the requirements of GNR 320.

2.3 THE ENVIRONMENT CONSERVATION ACT, 1989 (ACT 73 OF 1989)

The Environment Conservation Act, 1989 (Act 73 of 1989) ("ECA") allowed the Minister of Environmental Affairs and Tourism to make regulations regarding noise, among other concerns. The Minister has implemented Noise Control Regulations under the ECA as discussed below.

2.3.1 Noise Control Regulations (GN R154 of 1992)

In terms of section 25 of the ECA, the national Noise Control Regulations (GN R154 in *Government Gazette* No. 13717 dated 10 January 1992) ("NCRs") were promulgated. The NCRs were revised under Government Notice No. R. 55 of 14 January 1994 to make it obligatory for all authorities to apply the regulations. Provincial Noise Control Regulations exists in the Free State, Gauteng and Western Cape provinces.

2.3.2 Noise Control Regulations: Gauteng Province (GN 5479 of 20 August 1999)

The Gauteng Noise Control Regulations is based on the National Noise Control Regulations and most of the regulations are the same. It prohibits the generation of a disturbing noise in any manner (Regulation 8) and defines and prohibits activities that can result in a noise nuisance (Regulation 9). Regulation 11(1) allows a local authority to designate a controlled area as well as zone sound levels for specific areas and during specific times.

The difference between the National Noise Control Regulations and the Gauteng Province is the criteria set out for a controlled area, namely:

"controlled area" means a piece of land designed by a local authority where, in the case of-

(a) road traffic noise in the vicinity of a road-

- (i) the reading on an integrating impulse sound level meter, taken outdoors at the end of a period of 24 hours while such meter was in operation, exceeds 60 dBA; or

- (ii) the outdoor equivalent continuous "A" -weighed sound pressure level at a height of at least 1,2 metres, but not more than 1,4 metres, above the ground for a period of 24 hours as calculated in accordance with SABS 0210, and projected for a period of 15 years following the date on which the local authority has made such designation, exceeds 60 dBA.

It should be noted that the regulations define:

"ambient sound level"⁴ - means the reading on an integrating impulse sound level meter taken at a measuring point in the absence of any alleged disturbing noise at the end of a total period of at least 10 minutes after such meter was put into operation;

"disturbing noise" - means a noise level that causes the ambient noise level to rise above the designated zone level, or if no zone level has been designated, the typical rating levels for ambient noise in districts, indicated in table 2 of SABS 0103;

"noise level" - means the reading on an integrating impulse sound level meter taken at a measuring point in the presence of any alleged disturbing noise at the end of a total period of at least 10 minutes after such meter was put into operation, and, if the alleged disturbing noise has a discernible pitch, for example, a whistle, buzz, drone or music, to which 5 dBA has been added;

In addition:

In terms of Regulation 8 of the Noise Control Regulations:

"No person shall make, produce or cause a disturbing noise, or allow it to be made, produced or caused by any person, machine, device or apparatus or any combination thereof".

In terms of Regulation 10(1):

"No person shall –

- (b) make changes to existing facilities or existing uses of land or buildings or erect new buildings, if these will house or cause activities, that will, after such changes or erection, cause a disturbing noise, unless precautionary measures to prevent the disturbing noises have been taken to the satisfaction of the local authority;*
- (d) if required by a local authority, install, replace or modify a plant with a total input power exceeding 10 kilowatts on any premises, unless the local authority has been notified by the owner of the plant in writing at least 14 days before such installation, replacement or modification;*

⁴ This is the same as the Residual Noise Level as defined in the later SANS 10103:2008 and SANS 10328:2008

In terms of Regulation 10(2):

"The local authority may –

- (a) before changes are made to existing facilities or existing uses of land or buildings or before new buildings are erected, in writing require that noise impact assessments or tests be conducted to the satisfaction of that local authority by the owner, developer, tenant or occupant of the facilities, land or buildings and that reports or certificates relating to the noise impact to the satisfaction of that local authority be submitted by the owner, developer, tenant or occupant to the local authority on written demand;*

2.4 INTERNATIONAL GUIDELINES

While there exists a number of international guidelines and standards that could encompass a document in itself, the three mentioned below were selected as they are used by different countries in the subject of environmental noise management, with the last two documents specifically focussing on the noises associated by WEFs.

2.4.1 Guidelines for Community Noise (World Health Organization, 1999)

The World Health Organization's (WHO) document on the *Guidelines for Community Noise* is the outcome of the WHO- expert task force meeting held in London, United Kingdom, in April 1999. It is based on the document entitled "Community Noise" that was prepared for the WHO and published in 1995 by the Stockholm University and Karolinska Institute.

The scope of the WHO's effort to derive guidelines for community noise is to consolidate actual scientific knowledge on the health impacts of community noise and to provide guidance to environmental health authorities and professionals trying to protect people from the harmful effects of noise in non-industrial environments.

Guidance on the health effects of noise exposure of the population has already been given in an early publication of the series of Environmental Health Criteria. The health risk to humans from exposure to environmental noise was evaluated and guidelines values derived. The issue of noise control and health protection was briefly addressed.

The document uses the L_{Aeq} and L_{Amax} descriptors to define noise levels. This document was important in the development of the SANS 10103 standard.

2.4.2 The Assessment and Rating of Noise from Wind Farms (Energy Technology Support Unit, 1997)

This report describes the findings of a Working Group on Wind Turbine Noise, facilitated by the United Kingdom Department of Trade and Industry. It was developed as an Energy Technology Support Unit⁵ (ETSU) project. The aim of the project was to provide information and advice to developers and planners on noise from wind turbines. The report represents the consensus view of a number of experts (experienced in assessing and controlling the environmental impact of noise from wind farms). Their findings can be summarised as follow:

1. Absolute noise limits applied at all wind speeds are not suited to wind farms; limits set relative to the background noise (including wind as seen in **Figure 4-3**) are more appropriate;
2. $L_{A90,10\text{mins}}$ is a much more accurate descriptor when monitoring ambient and turbine noise levels;
3. The effects of other wind turbines in a given area should be added to the effect of any proposed WF, to calculate the cumulative effect;
4. Noise from a WEF should be restricted to no more than 5 dBA above the current ambient noise level at an NSR. Ambient noise levels are measured onsite in terms of the $L_{A90,10\text{min}}$ descriptor for a period sufficiently long enough for a set period;
5. Wind farms should be limited within the range of 35 dBA to 40 dBA (day-time) in a low noise environment. A fixed limit of 43 dBA should be implemented during all night time noise environments. This should increase to 45 dBA (day and night) if the NSR has financial investments in the WF; and
6. A penalty system should be implemented for wind turbine/s that operates with a tonal characteristic.

This is likely the guideline used in the most international countries to estimate the potential noise impact stemming from the operation of a WEF. It also recommends an improved methodology (compared to a fixed upper noise level) on determining ambient sound levels in periods of higher wind speeds, critical for the development of a wind energy facility. Because of its international importance, the methodologies used in the ETSU R97 document will be recommended in this report for implementation should projected noise levels (from the proposed WEF at NSR) exceed the zone sound levels as recommended by SANS 10103:2008.

⁵ ETSU was set up in 1974 as an agency by the United Kingdom Atomic Energy Authority to manage research programmes on renewable energy and energy conservation. The majority of projects managed by ETSU were carried out by external organizations in academia and industry. In 1996, ETSU became part of AEA Technology plc which was separated from the UKAEA by privatization.

2.4.3 Noise Guidelines for Wind Farms (MoE, 2008)

This document establishes the sound level limits for land-based wind power generating facilities and describes the information required for noise assessments and submissions under the ECA and the Environmental Protection Act, Canada.

The document defines:

- Sound Level Limits for different areas (similar to rural and urban areas), defining limits for different wind speeds at 10 m height, refer also **Table 2-1**⁶
- The Noise Assessment Report, including:
 - Information that must be part of the report;
 - Full description of noise sources;
 - Adjustments, due to the wind speed profile (wind shear);
 - The identification and defining of potential sensitive receptors;
 - Prediction methods to be used (ISO 9613-2);
 - Cumulative impact assessment requirements;
 - It also defines specific model input parameters;
 - Methods on how the results must be presented; and
 - Assessment of Compliance (defining magnitude of noise levels).

Table 2-1: Summary of Sound Level Limits for Wind Farms (MoE)

Wind speed (m/s) at 10 m height	4	5	6	7	8	9	10
Wind Turbine Sound Level Limits, Class 3 Area, dBA	40	40	40	43	45	49	51
Wind Turbine Sound Level Limits, Class 1 & 2 Areas, dBA	45	45	45	45	45	49	51

The document used the $L_{Aeq,1h}$ noise descriptor to define noise levels.

It should be noted that these Sound Level Limits are included for the reader to illustrate the criteria used internationally. Due to the lack of local regulations specifically relevant to WEFs this criterion will also be considered during the determination of the significance of the noise impact.

2.4.4 Equator Principles

The **Equator Principles** (EPs) are a voluntary set of standards for determining, assessing and managing social and environmental risk in project financing. Equator Principles Financial Institutions (EPFIs) commit to not providing loans to projects where the borrower will not or is

⁶The measurement of wind induced background sound level is not required to establish the applicable limit. The wind induced background sound level reference curve was determined by correlating the A-weighted ninetyth percentile sound level (L90) with the average wind speed measured at a particularly quiet site. The applicable Leq sound level limits at higher wind speeds are given by adding 7 dB to the wind induced background L90 sound level reference values

unable to comply with their respective social and environmental policies and procedures that implement the EPs.

The EPs were developed by private sector banks and were launched in June 2003. The banks chose to model the EPs on the environmental standards of the World Bank and the social policies of the International Finance Corporation (IFC). As of March 2021, 116 financial institutions (located in 37 different countries) have adopted the EPs, which have become the de facto standard for banks and investors on how to assess major development projects around the world. The environmental standards of the World Bank have been integrated into the social policies of the IFC since April 2007 as the IFC Environmental, Health and Safety (EHS) Guidelines.

2.4.5 IFC: General EHS Guidelines – Environmental Noise Management (IFC, 2007)

These guidelines are applicable to noise created beyond the property boundaries of a development that conforms to the EPs.

It states that noise prevention and mitigation measures should be applied where predicted or measured noise impacts from a project facility or operations exceed the applicable noise level guideline at the most sensitive point of reception. The preferred method for controlling noise from stationary sources is to implement noise control measures at the source.

It goes as far as to propose methods for the prevention and control of noise emissions, including:

- Selecting equipment with lower sound power levels;
- Installing silencers for fans;
- Installing suitable mufflers on engine exhausts and compressor components;
- Installing acoustic enclosures for equipment casing radiating noise;
- Improving the acoustic performance of constructed buildings, apply sound insulation;
- Installing acoustic barriers without gaps and with a continuous minimum surface density of 10 kg/m² in order to minimize the transmission of sound through the barrier. Barriers should be located as close to the source or to the receptor location to be effective;
- Installing vibration isolation for mechanical equipment;
- Limiting the hours of operation for specific pieces of equipment or operations, especially mobile sources operating through community areas;
- Re-locating noise sources to less sensitive areas to take advantage of distance and shielding;
- Placement of permanent facilities away from community areas if possible;
- Taking advantage of the natural topography as a noise buffer during facility design;

- Reducing project traffic routing through community areas wherever possible;
- Planning flight routes, timing and altitude for aircraft (airplane and helicopter) flying over community areas; and
- Developing a mechanism to record and respond to complaints.

It sets noise level guidelines (see **Table 2-2**) as well as highlighting the certain monitoring requirements pre- and post-development.

Table 2-2: IFC Table 7.1-Noise Level Guidelines

Receptor type	One hour L_{Aeq} (dBA)	
	Daytime 07:00 - 22:00	Night-time 22:00 - 07:00
Residential; institutional; educational	55	45
Industrial; commercial	70	70

The document uses the $L_{Aeq,1\text{ hr}}$ noise descriptors to define noise levels. It does not determine the detection period, but refers to the International Electrotechnical Commission (IEC) Standards, which require the fast detector setting on the Sound Level Meter during measurements for Europe.

2.4.6 Environmental, Health, and Safety Guidelines for Wind Energy (WBG, 2015) [36]

The EHS Guidelines for wind energy include information relevant to environmental, health, and safety aspects of onshore and offshore wind energy facilities was published by the World Bank Group (“WBG”). It should be applied to wind energy facilities from the earliest feasibility assessments from the time of the environmental impact assessment, and continue to be applied throughout the construction and operational phases.

When host country regulations differ from the levels and measures presented in the EHS Guidelines, projects are expected to achieve whichever are more stringent. If less stringent levels or measures than those provided in these EHS Guidelines are appropriate, in view of specific project circumstances, a full and detailed justification for any proposed alternatives is needed as part of the site-specific environmental assessment.

It provides a brief overview of construction and operational noises, potential operational mitigation measures and a number of principles on the assessment of noise impacts, including:

- Receptors should be chosen according to their environmental sensitivity (human, livestock, or wildlife);
- Preliminary modeling should be carried out to determine whether more detailed investigation is warranted. The preliminary modeling can be as simple as assuming

hemispherical propagation (i.e., the radiation of sound, in all directions, from a source point). Preliminary modeling should focus on sensitive receptors within 2,000 meters (m) of any of the turbines in a wind energy facility;

- If the preliminary model suggests that turbine noise at all sensitive receptors is likely to be below an L_{A90} of 35 dBA at a wind speed of 10 meters/second (m/s) at 10 m height during day and night times, then this preliminary modeling is likely to be sufficient to assess noise impact; otherwise it is recommended that more detailed modeling be carried out, which may include background ambient noise measurements;
- All modeling should take account of the cumulative noise from all wind energy facilities in the vicinity having the potential to increase noise levels;
- If noise criteria based on ambient noise are to be used, it is necessary to measure the background noise in the absence of any wind turbines. This should be done at one or more noise-sensitive receptors. Often the critical receptors will be those closest to the wind energy facility, but if the nearest receptor is also close to other significant noise sources, an alternative receptor may need to be chosen; and
- The background noise should be measured over a series of 10-minute intervals, using appropriate wind screens. At least five of these 10-minute measurements should be taken for each integer wind speed from cut-in speed to 12 m/s.

This project would mainly use the terms of reference defined by the Guidelines and Protocols stipulated in South Africa, but, as these guidelines and protocols are not specifically for wind projects, would also consider the World Bank EHS recommendations. As there are NSR located within 2,000m from WTG, a comprehensive environmental noise impact assessment, inclusive of detailed noise modelling (for the operational phase), will be undertaken.

2.4.7 Environmental Noise Guidelines for the European Region (WHO, 2018) [39]

This document identifies levels at which noise has “adverse health effects” and recommends actions to reduce exposure. Compared to previous WHO guidelines on noise, this version contains five significant developments:

- Stronger evidence of the cardiovascular and metabolic effects of environmental noise;
- Inclusion of new noise sources, namely wind turbine noise and leisure noise, in addition to noise from transportation (aircraft, rail, and road traffic);
- Use of a standardized approach to assess the evidence;
- A systematic review of evidence, defining the relationship between noise exposure and risk of adverse health outcomes;
- Use of long-term average noise exposure indicators to better predict adverse health outcomes.

The WHO (2018) considers adverse health effects in **section 2.4.3.2** of their report, dividing these effects into the following health outcomes:

- Cardiovascular disease – Ischaemic heart disease and hypertension;
- Cognitive impairment – Reading and oral comprehension;
- Permanent hearing impairment; and
- Self-reported sleep disturbance and annoyance.

While the WHO (2018) highlights that there is insufficient evidence of adverse health effects at noise levels below 40 dBA L_{night} , adverse health effects were reported at levels starting from 40 dB L_{night} . At 40 dB, about 3–4% of the population still reported being highly sleep-disturbed due to noise, which was considered relevant to health. It recommends that the guideline level should minimise adverse health effects to less than:

- 3% of the population experiencing sleep disturbances; and
- 10% of the population being highly annoyed.

This report recommends, that, for average noise exposure, the WHO Guideline Development Group conditionally recommends reducing noise levels produced by wind turbines below 45 dB L_{den}^7 , as wind turbine noise above this level is associated with adverse health effects.

⁷ Day–evening–night noise level is a European standard to express noise level over an entire day. It imposes a penalty on sound levels during evening and night and it is primarily used for noise assessments of airports, busy main roads, main railway lines and in cities over 100,000 residents. This equates to a night-time equivalent noise level of approximately 38.7 dBA.

3 POTENTIAL NOISE SOURCES

Increased noise levels are directly linked with the various activities associated with the construction of the proposed Igolide WEF and related infrastructure, as well as the operation phase of the activity. The potential noise impacts from the activities associated with these phases are discussed in the following sections.

3.1 POTENTIAL NOISE SOURCES: CONSTRUCTION PHASE

3.1.1 Construction equipment

It is estimated that construction will take approximately 24 – 36 months subject to the final design of the WEF, weather and ground conditions, including time for testing and commissioning. The construction process will consist of the following principal activities:

- Site survey and preparation;
- Establishment of site entrance, internal access roads, contractors' compound and passing places;
- Civil works to sections of the public roads to facilitate with turbine delivery;
- Site preparation activities will include clearance of vegetation at the footprint of each turbine as well as crane hard-standing areas. These activities will require the stripping of topsoil which will need to be stockpiled, backfilled and/or spread on site;
- Construct foundations – due to the volume of concrete that will be required, an on-site batching plant will be required to ensure a continuous concreting operation. The source of aggregate is yet to be determined but is expected to be derived from an offsite source or brought in as ready-mix. If the stones removed during the digging of foundations are suitable as an aggregate this may be used as the aggregate in the concrete mix.
- Transport of components & equipment to site – all components will be brought to site in sections by means of flatbed trucks. Additionally, components of various specialized construction and lifting equipment are required on site to erect the wind turbines and will need to be transported to site. The typical civil engineering construction equipment will need to be brought to the site for the civil works (e.g. excavators, trucks, graders, compaction equipment, cement trucks, etc.). The transportation of ready-mix concrete to site or the materials for onsite concrete batching will result in a temporary increase in heavy traffic (one turbine foundation may require up to 100 concrete trucks, and is undertaken as a continuous pour);
- Establishment of laydown & hard standing areas - laydown areas will need to be established at each turbine position for the placement of wind turbine components. Laydown and storage areas will also be required to be established for the civil

engineering construction equipment which will be required on site. Hard standing areas will need to be established for operation of the cranes. Cranes of the size required to erect turbines are sensitive to differential movement during lifting operations and require a hard-standing area;

- Erect turbines - a crane will be used to lift the tower sections into place and then the nacelle will be placed onto the top of the assembled tower. The next step will be to assemble or partially assemble the rotor on the ground; it will then be lifted to the nacelle and bolted in place. A small crane will likely be needed for the assembly of the rotor while the large crane will be needed to put it in place;
- Construct substation - the underground cables carrying the generated power from the individual turbines will connect at the substation. The construction of the substation would require a site survey; site clearing and levelling (including the removal / cutting of rock outcrops) and construction of access road/s (where required); construction of a substation terrace and foundation; assembly, erection and installation of equipment (including transformers); connection of conductors to equipment; and rehabilitation of any disturbed areas and protection of erosion sensitive areas;
- Establishment of ancillary infrastructure - A workshop as well as a contractor's equipment camp may be required. The establishment of these facilities/buildings will require the clearing of vegetation and levelling of the development site and the excavation of foundations prior to construction. A laydown area for building materials and equipment associated with these buildings will also be required; and
- Site rehabilitation - once construction is completed and all construction equipment are removed; the site will be rehabilitated where practical and reasonable.

There are a number of factors that determine the audibility as well as the potential of a noise impact on receptors. Maximum noises generated can be audible over a large distance, however, these maximum noises are generally of very short duration. If maximum noise levels however exceed 65 dBA at a receptor, or if it is clearly audible with a significant number of instances where the noise level exceeds the prevailing ambient sound level with more than 15 dB, the noise can increase annoyance levels and may ultimately result in noise complaints. Potential maximum noise levels generated by various construction equipment as well as the potential extent of these sounds are presented in **Table 3-1**.

Average or equivalent sound levels are another factor that impacts on the ambient sound levels and is the constant sound level that the receptor can experience. Typical sound power levels associated with various activities that may be found at a construction site are presented in **Table 3-2**.

Table 3-1: Potential maximum noise levels generated by construction equipment

Equipment Description ⁸	Impact Device?	Maximum Sound Power Levels (dBA)	Operational Noise Level at given distance considering potential maximum noise levels (Cumulative as well as the mitigatory effect of potential barriers or other mitigation not included – simple noise propagation modeling only considering distance) (dBA)											
			5 m	10 m	20 m	50 m	100 m	150 m	200 m	300 m	500 m	750 m	1000 m	2000 m
Auger Drill Rig	No	119.7	94.7	88.7	82.6	74.7	68.7	65.1	62.6	59.1	54.7	51.2	48.7	42.6
Backhoe	No	114.7	89.7	83.7	77.6	69.7	63.7	60.1	57.6	54.1	49.7	46.2	43.7	37.6
Compactor (ground)	No	114.7	89.7	83.7	77.6	69.7	63.7	60.1	57.6	54.1	49.7	46.2	43.7	37.6
Concrete Batch Plant	No	117.7	92.7	86.7	80.6	72.7	66.7	63.1	60.6	57.1	52.7	49.2	46.7	40.6
Concrete Mixer Truck	No	119.7	94.7	88.7	82.6	74.7	68.7	65.1	62.6	59.1	54.7	51.2	48.7	42.6
Crane	No	119.7	94.7	88.7	82.6	74.7	68.7	65.1	62.6	59.1	54.7	51.2	48.7	42.6
Dozer	No	119.7	94.7	88.7	82.6	74.7	68.7	65.1	62.6	59.1	54.7	51.2	48.7	42.6
Drill Rig Truck	No	118.7	93.7	87.7	81.6	73.7	67.7	64.1	61.6	58.1	53.7	50.2	47.7	41.6
Excavator	No	119.7	94.7	88.7	82.6	74.7	68.7	65.1	62.6	59.1	54.7	51.2	48.7	42.6
Flat Bed Truck	No	118.7	93.7	87.7	81.6	73.7	67.7	64.1	61.6	58.1	53.7	50.2	47.7	41.6
Front End Loader	No	114.7	89.7	83.7	77.6	69.7	63.7	60.1	57.6	54.1	49.7	46.2	43.7	37.6
Grader	No	119.7	94.7	88.7	82.6	74.7	68.7	65.1	62.6	59.1	54.7	51.2	48.7	42.6
Impact Pile Driver	Yes	129.7	104.7	98.7	92.6	84.7	78.7	75.1	72.6	69.1	64.7	61.2	58.7	52.6
Rivit Buster/Chipping Gun	Yes	119.7	94.7	88.7	82.6	74.7	68.7	65.1	62.6	59.1	54.7	51.2	48.7	42.6
Slurry Plant	No	112.7	87.7	81.7	75.6	67.7	61.7	58.1	55.6	52.1	47.7	44.2	41.7	35.6
Slurry Trenching Machine	No	116.7	91.7	85.7	79.6	71.7	65.7	62.1	59.6	56.1	51.7	48.2	45.7	39.6
Soil Mix Drill Rig	No	114.7	89.7	83.7	77.6	69.7	63.7	60.1	57.6	54.1	49.7	46.2	43.7	37.6
Tractor	No	118.7	93.7	87.7	81.6	73.7	67.7	64.1	61.6	58.1	53.7	50.2	47.7	41.6
Vibratory Concrete Mixer	No	114.7	89.7	83.7	77.6	69.7	63.7	60.1	57.6	54.1	49.7	46.2	43.7	37.6
Vibratory Pile Driver	No	129.7	104.7	98.7	92.6	84.7	78.7	75.1	72.6	69.1	64.7	61.2	58.7	52.6
Warning Horn	No	119.7	94.7	88.7	82.6	74.7	68.7	65.1	62.6	59.1	54.7	51.2	48.7	42.6
Welder/Torch	No	107.7	82.7	76.7	70.6	62.7	56.7	53.1	50.6	47.1	42.7	39.2	36.7	30.6

⁸ Equipment list and Sound Power Level source: http://www.fhwa.dot.gov/environment/noise/construction_noise/handbook/handbook09.cfm

Table 3-2: Potential equivalent noise levels generated by various equipment

Equipment Description	Equivalent (average) Sound Levels (dBA)	Operational Noise Level at given distance considering equivalent (average) sound power emission levels (Cumulative as well as the mitigatory effect of potential barriers or other mitigation not included – simple noise propagation modelling only considering distance) (dBA)											
		5 m	10 m	20 m	50 m	100 m	150 m	200 m	300 m	500 m	750 m	1000 m	2000 m
Air compressor	92.6	67.6	61.6	55.5	47.6	41.6	38.0	35.5	32.0	27.6	24.1	21.6	15.5
Bulldozer CAT D10	111.9	86.9	80.9	74.9	66.9	60.9	57.4	54.9	51.3	46.9	43.4	40.9	34.9
Cement truck (with cement)	111.7	86.7	80.7	74.7	66.7	60.7	57.2	54.7	51.2	46.7	43.2	40.7	34.7
Crane	107.5	82.5	76.5	70.5	62.5	56.5	53.0	50.5	46.9	42.5	39.0	36.5	30.5
Diesel Generator (Large - mobile)	106.1	81.2	75.1	69.1	61.2	55.1	51.6	49.1	45.6	41.2	37.6	35.1	29.1
Dumper/Haul truck - Terex 30 ton	112.2	87.2	81.2	75.2	67.2	61.2	57.7	55.2	51.7	47.2	43.7	41.2	35.2
Excavator - Hitachi EX1200	113.1	88.1	82.1	76.1	68.1	62.1	58.6	56.1	52.6	48.1	44.6	42.1	36.1
FEL (988) (FM)	115.6	90.7	84.6	78.6	70.7	64.6	61.1	58.6	55.1	50.7	47.1	44.6	38.6
General noise	108.8	83.8	77.8	71.8	63.8	57.8	54.2	51.8	48.2	43.8	40.3	37.8	31.8
Grader - Operational Hitachi	108.9	83.9	77.9	71.9	63.9	57.9	54.4	51.9	48.4	43.9	40.4	37.9	31.9
Road Truck average	109.6	84.7	78.7	72.6	64.7	58.7	55.1	52.6	49.1	44.7	41.1	38.7	32.6
Rock Breaker, CAT	120.7	95.7	89.7	83.7	75.7	69.7	66.2	63.7	60.2	55.7	52.2	49.7	43.7
Vibrating roller	106.3	81.3	75.3	69.3	61.3	55.3	51.8	49.3	45.8	41.3	37.8	35.3	29.3
Water Dozer, CAT	113.8	88.8	82.8	76.8	68.8	62.8	59.3	56.8	53.3	48.8	45.3	42.8	36.8
Wind Turbine: Acciona AW125/3000	108.5	83.5	77.5	71.5	63.5	57.5	54.0	51.5	48.0	43.5	40.0	37.5	31.5
Wind Turbine: Goldwind GW165-6.0	112.6	87.6	81.6	75.6	67.6	61.6	58.1	55.6	52.1	47.6	44.1	41.6	35.6
Wind Turbine: Nordex N163 / 5.X	109.2	84.2	78.2	72.2	64.2	58.2	54.7	52.2	48.7	44.2	40.7	38.2	32.2
Wind Turbine: Vesta V66, ave	102.6	77.7	71.6	65.6	57.7	51.6	48.1	45.6	42.1	37.7	34.1	31.6	25.6
Wind Turbine: Vesta V66, max	108.0	83.0	77.0	71.0	63.0	57.0	53.5	51.0	47.5	43.0	39.5	37.0	31.0
Wind Turbine: Vesta V66, min	96.3	71.3	65.3	59.3	51.3	45.3	41.8	39.3	35.8	31.3	27.8	25.3	19.3
Wind Turbine: Vesta V90 2 MW VCS	104.0	79.0	73.0	67.0	59.0	53.0	49.5	47.0	43.5	39.0	35.5	33.0	27.0
Wind Turbine: Vestas V117 3.3MW	107.0	82.0	76.0	70.0	62.0	56.0	52.5	50.0	46.4	42.0	38.5	36.0	30.0
Wind Turbine: Vestas V150-4.2 MW	104.9	79.9	73.9	67.9	60.0	54.0	50.4	48.0	44.5	40.0	36.5	34.0	28.0

The equipment likely to be required to complete the above tasks will typically include:

- excavator/graders, bulldozer(s), dump trucks(s), vibratory roller, bucket loader, rock breaker(s), drill rig, flatbed truck(s), pile drivers, TLB, concrete truck(s), crane(s), fork lift(s) and various 4WD and service vehicles.

3.1.2 Blasting

Blasting may be required as part of the civil works to clear obstacles or to prepare foundations. Should a borrow pit be used to supply rocks for construction purposes, blasting could also be expected. However, no information regarding the use, or even the feasibility of such a borrow pit is known.

However, blasting will not be considered for the following reasons:

- Blasting is highly regulated, and control of blasting to protect human health, equipment and infrastructure will ensure that any blasts will use minimum explosives and will occur in a controlled manner. With regards to blasting in borrow pits, explosives are used with a low detonation speed, reducing vibration, sound pressure levels and air blasts. The breaking of obstacles with explosives is also a specialized field, and when correct techniques are used, it causes less noise than using a rock-breaker.
- People are generally more concerned over ground vibration and air blast levels that might cause building damage than the impact of the noise from the blast.
- Blasts are an infrequent occurrence, with a loud but a relative instantaneous character. Potentially affected parties normally receive sufficient notice (siren), and the knowledge that the duration of the siren noise as well as the blast will be over relatively fast, resulting in a higher acceptance of the noise.

3.1.3 Traffic

A potential significant source of noise during the construction phase is additional traffic to and from the site, as well as traffic on the site. The use of a borrow pit(s), on site crushing and screening and concrete batching plants will significantly reduce heavy vehicle movement to and from the site.

Construction traffic is expected to be generated throughout the entire construction period, however, the volume and type of traffic generated will be dependent upon the construction activities being conducted, which will vary during the construction period. Noise levels due to traffic can be estimated using various different noise algorithms.

3.2 POTENTIAL NOISE SOURCES: OPERATION PHASE

The proposed development would be designed to have an operational life of up to 25 years with the possibility to further expand the lifetime of the WEF. The only development related activities on-site will be routine servicing (access roads and light traffic) and unscheduled maintenance. The noise impact from maintenance activities is insignificant, with the main noise source being the wind turbine blades and the nacelle (components inside) as highlighted in the following sections.

Noise emitted by wind turbines can be associated with two types of noise sources. These are aerodynamic sources due to the passage of air over the wind turbine blades and mechanical sources which are associated with components of the power train within the turbine, such as the gearbox and generator and control equipment for yaw, blade pitch, etc. These sources normally have different characteristics and can be considered separately. In addition, there are other noise sources of lower levels, such as the substations and traffic (maintenance).

3.2.1 Wind Turbine Noise: Aerodynamic sources⁹

Aerodynamic noise is emitted by a wind turbine blade through a number of sources such as:

1. Self-noise due to the interaction of the turbulent boundary layer with the blade trailing edge.
2. Noise due to inflow turbulence (turbulence in the wind interacting with the blades).
3. Discrete frequency noise due to trailing edge thickness.
4. Discrete frequency noise due to laminar boundary layer instabilities (unstable flow close to the surface of the blade).
5. Noise generated by the rotor tips.

Therefore, as the wind speed increases, noises created by the wind turbine also increase. At a low wind speed the noise created by the wind turbine is generally (relatively) low, and increases to a maximum at a certain wind speed when it either remains constant, increase very slightly or even drops as illustrated in **Figure 3-1**.

⁹ *Renewable Energy Research Laboratory, 2006; ETSU R97: 1996*

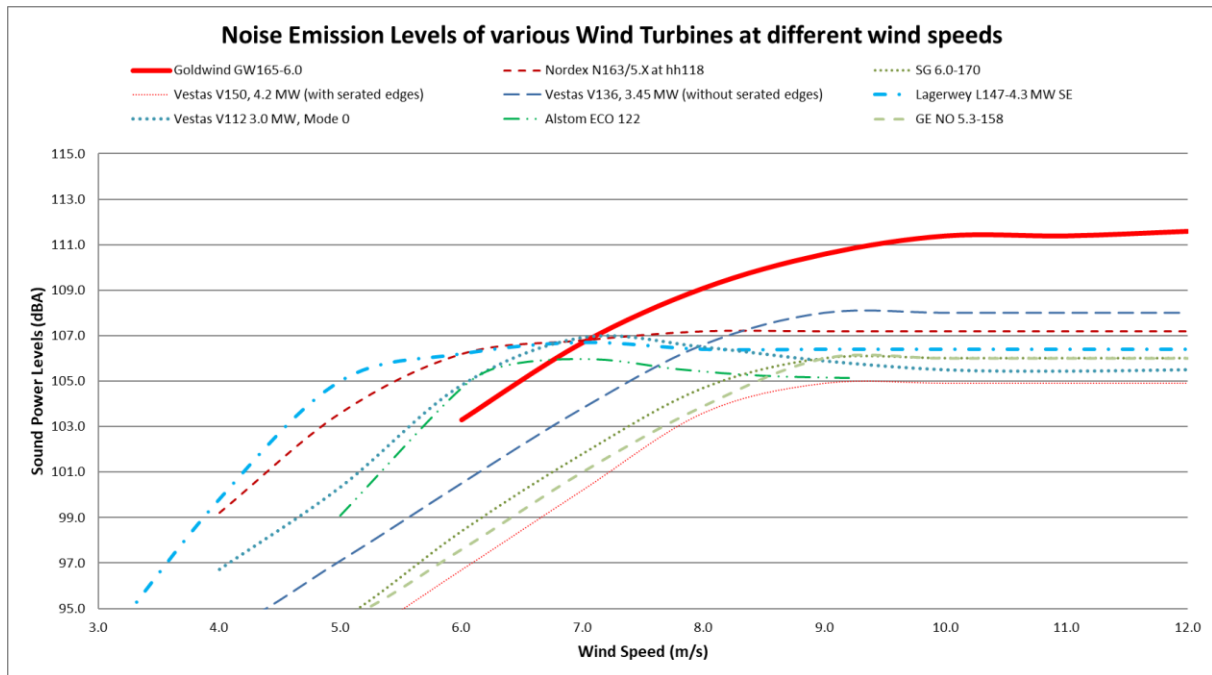

Figure 3-1: Noise Emissions Curve of a number of different wind turbines (figure for illustration purposes only)

3.2.1.1 Control Strategies to manage Noise Emissions during operation

Wind turbine manufacturers also provide their equipment with control mechanisms to allow for a certain noise reduction during operation that can include:

- A reduction of rotational speed;
- The increase of the pitch angle and/or reduction of nominal generator torque to reduce the angle of attack;
- Implementation of blade technologies such as serrated edges, changing the shape of the blade tips or the edge (proprietary technologies); and
- The insulation of the nacelle.

These mechanisms are used in various ways to allow the reduction of noise levels from the wind turbines, although this may also result in a reduction of power generation.

3.2.2 Wind Turbine: Mechanical sources¹⁰

Mechanical noise is normally perceived within the emitted noise from wind turbines as an audible tone(s) which is subjectively more intrusive than a broad band noise of the same sound pressure level. Sources for this noise are normally associated with:

- the gearbox and the tooth mesh frequencies of the step-up stages;

¹⁰ Renewable Energy Research Laboratory, 2006; ETSU R97: 1996; Audiology Today, 2010; HGC Engineering, 2007

- generator noise caused by coil flexure of the generator windings which is associated with power regulation and control;
- generator noise caused by cooling fans; and
- control equipment noise caused by hydraulic compressors for pitch regulation and yaw control.

Tones are noises with a narrow sound frequency composition (e.g., the whine of an electrical motor). Annoying tones can be created in numerous ways: machinery with rotating parts such as motors, gearboxes, fans and pumps often create tones. An imbalance or repeated impacts may cause vibration that, when transmitted through surfaces into the air, can be heard as tones. Pulsating flows of liquids or gases can also create tones, which may be caused by combustion processes or flow restrictions. The best and most well-known example of a tonal noise is the buzz created by a flying mosquito.

Where complaints have been received due to the operation of wind farms, tonal noise from the installed wind turbines appears to have increased the annoyance perceived by the complainants and has indeed been the primary cause for complaint.

However, tones were normally associated with the older models of turbines. All turbine manufacturers have started to ensure that sufficient forethought is given to the design of quieter gearboxes and the means by which these vibration transmission paths may be broken. Through the use of careful gearbox design and/or the use of anti-vibration techniques, it is possible to minimize the transmission of vibration energy into the turbine supporting structure. The benefits of these design improvements have started to filter through into wind farm developments which are using these modified wind turbines. ***New generation wind turbine generators do not emit any clearly distinguishable tones.***

3.2.3 Low Frequency Noise¹¹

Low frequency sound is the term used to describe sound energy in the region below ~200 Hz. The rumble of thunder and the throb of a diesel engine are both examples of sounds with most of their energy in this low frequency range. Infrasound is often used to describe sound energy in the region below 20 Hz.

Almost all noise in the environment has components in this region although they are of such a low level that they are not significant (wind, ocean, thunder). Sound that has most

¹¹ Renewable Energy Research Laboratory, 2006; DELTA, 2008; DEFRA, 2003; HGC Engineering, 2006; Whitford, Jacques, 2008; Noise-con, 2008; Minnesota DoH, 2009; Kamperman, 2008, Van den Berg, 2004

of its energy in the 'infrasound' range is only significant if it is at a very high level, far above normal environmental levels.

Because of the low rotational rates of the blades of a wind turbines, the peak acoustic energy radiated by large wind turbines is in the infrasonic range with a peak in the 8-12 Hz range. For smaller machines, this peak can extend into the low-frequency "audible" (20-20KHz) range because of higher rotational speeds and multiple blades.

It should be noted that a number of studies highlighted that these sounds are below the threshold of perception (BWEA, 2005), although this should be clarified. Most acousticians would agree that the low frequency sounds are inaudible to most people, yet, there are a number of studies that highlight that it can be more perceptible to people inside their houses as well as people that are more sensitive to low frequency sounds.

Low frequency noise is always present around us as it is produced by both man and nature. While problems have been associated with older downwind wind turbines in the 1980s, this has been considered by the wind industry and modern upwind turbines do not suffer from the same problems. Low Frequency Noise however has been very controversial in the last few years with the anti-wind fraternity claiming measurable impacts, with governments and wind-energy supporter studies indicating no link between low-frequency sound and any health impacts.

3.2.4 Amplitude modulation¹²

Although considered rare, there is one other characteristic of wind turbine sound that increases the sleep disturbance potential above that of other long-term noise sources. The amplitude modulation (AM) of the sound emissions from the wind turbines creates a repetitive rise and fall in sound levels synchronized to the blade rotation speed, sometimes referred to as a "swish" or "thump".

Pedersen (2003) highlighted a weak correlation between sound pressure level and noise annoyance caused by wind turbines. Residents complaining about wind turbines noise perceived more sound characteristics than noise levels. People were able to distinguish between background ambient sounds and the sounds the blades made. The noise produced by the blades lead to most complaints. Most of the annoyance was experienced between 16:00 and midnight. This could be an issue as noise propagation modelling would be

¹² *Renewable Energy Research Laboratory, 2006; Audiology Today, 2010; HGC Engineering, 2007; Whitford, 2008; Noise-con, 2008; DEFRA, 2007; Bowdler, 2008*

reporting an equivalent, or “average” sound pressure level, a parameter that ignores the “character” of the sound.

That AM can be a risk and significantly increase the annoyance with WEFs cannot be disputed. It has been reported with a number of recent studies confirming this significant noise characteristic. However, even though there are thousands of wind turbine generators in the world, amplitude modulation is still one subject receiving the least complaints and due to these very few complaints, little research went into this subject. It is important to note that it is not possible to predict whether AM may occur, nor to calculate the potential related impact.

3.2.5 Battery Energy Storage Systems

The developer proposes to include a BESS at their WEF to store energy for use at a later time or date using electro-chemical solutions. The typical components of a BESS are:

- The battery system which could consist of:
 - o Multiple cells,
 - o The battery management system; and,
 - o The battery thermal management system.
- Components required for the reliable operation of the overall system, including:
 - o Energy management system; and,
 - o System thermal management.
- Power electronics that can be grouped into the conversion unit (such as an inverter), which manage the power flow between the grid and battery, including the required control and monitoring components, voltage sensing units and thermal management of power electronic components (fans or climate control system).

There could be numerous such BESS modules running in parallel to increase the total storage capacity of the system up to the desired or needed capacity. The typical components are illustrated in **Figure 3-2**.

While certain components may generate a slight hum under load, the dominant source of noise is from the fans or climate control system used to manage heat in the system and/or to maintain the BESS within its optimal operating temperature range. These BESSs however generate low noise levels, with any potential noise impact generally limited to areas within 200m of the BESS. This is an insignificant noise level and the significance of this noise will be low.

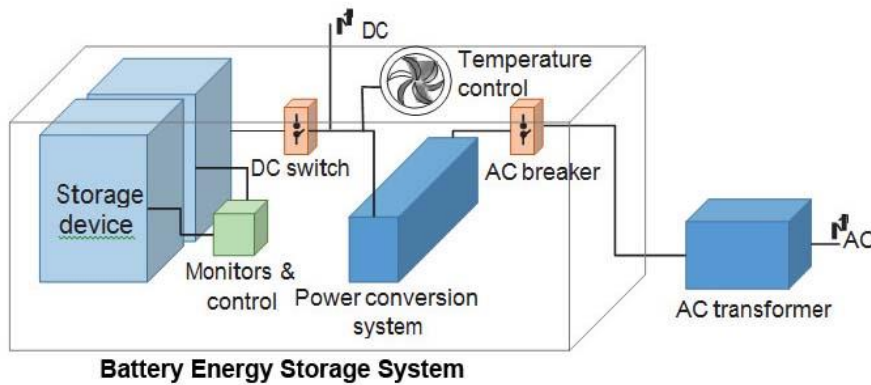

Figure 3-2: Conceptual BESS components¹³

3.2.6 Transformer noises (Substations)

Also known as magnetostriction¹⁴, is when the sheet steel used in the core of the transformer tries to change shape when being magnetised. When the magnetism is taken away, the shape returns, only to try and deform in a different manner when the polarity is changed.

This deformation is not uniform; consequently, it varies all over a sheet. With a transformer core being composed of many sheets of steel, these deformations are taking place erratically all over each sheet, and each sheet is behaving erratically with respect to its neighbour. The resultant is the "hum" frequently associated with transformers. While this may be a soothing sound in small home appliances, various complaints are logged in areas where people stay close to these transformers. At a voltage frequency of 50 Hz, these "vibrations" take place 100 times a second, resulting in a tonal noise at 100Hz.

However, this is a relatively easy noise to mitigate with the use of acoustic shielding and/or placement of the transformer and will not be considered further in this ENIA study. Substations in addition generate low noise levels, with the hum from the transformers inaudible further than 200 m from the transformers.

3.2.7 Transmission Line Noise (Corona noise)

Corona noise¹⁵ is caused by the partial breakdown of the insulation properties of air surrounding the conducting wires. It can generate an audible and radio-frequency noise, but generally only occurs in humid conditions, as provided by fog or rain. A minimum line

¹³ Source: <http://www.amdcenergy.com/battery-energy-storage-system.html>

¹⁴ <https://en.wikipedia.org/wiki/Magnetostriction>

¹⁵ https://en.wikipedia.org/wiki/Corona_discharge

potential of 70kV or higher is generally required to generate corona noise depending on the electrical design. Corona noise does not occur on domestic distribution lines.

Corona noise has two major components: a low frequency tone associated with the frequency of the AC supply (100 Hz for 50 Hz source) and broadband noise. The tonal component of the noise is related to the point along the electric waveform at which the air begins to conduct. This varies with each cycle and consequently the frequency of the emitted tone is subject to great fluctuations. Corona noise can be characterised as broadband 'crackling' or 'buzzing', but **fortunately it is generally only a feature that occurs during fog or rain.**

It will not be further investigated, as corona discharges results in:

- Power losses,
- Audible noises,
- Electromagnetic interference,
- A purple glow,
- Ozone production; and
- Insulation damage.

As such Electrical Service Providers, such as ESKOM, go to great lengths to design power transmission equipment to minimise the formation of corona discharges. In addition, it is an infrequent occurrence with a relatively short duration compared to other operational noises.

4 METHODOLOGY: NOISE SPECIALIST ASSESSMENT

4.1 NOISE IMPACT ON ANIMALS¹⁶

A great deal of research was conducted in the 1960's and 1970's on the effects of aircraft noise on animals. While aircraft noise has a specific characteristic, the findings should be relevant to most noise sources.

Overall, the research suggests that species differ in their response to:

- Various types of noise;
- Durations of noise; and
- Sources of noise.

A general animal behavioural reaction to aircraft noise is the startle response. However, the strength and length of the startle response appears to be dependent on:

- which species is exposed;
- whether there is one animal or a group; and
- whether there have been some previous exposures.

Unfortunately, there are numerous other factors in the environment of animals that also influence the effects of noise. These include predators, weather, changing prey/food base and ground-based disturbance, especially anthropogenic. This hinders the ability to define the real impact of noise on animals.

From these and other studies the following can be concluded:

- Animals respond to impulsive (sudden) noises (higher than 90 dBA) by running away. If the noises continue, animals would try to relocate. This is not relevant to wind energy facilities because the turbines do not generate any impulsive noises close to these sound levels.
- Animals of most species exhibit adaptation with noise, including aircraft noise and sonic booms (far worse than noises associated with Wind Turbines).
- More sensitive species would relocate to a quieter area, especially species that depend on hearing to hunt or evade prey, or species that makes use of sound/hearing to locate a suitable mate.
- Noises associated with helicopters, motor- and quad bikes significantly impact on animals.

¹⁶ Report to Congressional Requesters, 2005; USEPA, 1971; Autumn, 2007; Noise quest, 2010

4.2 WHY NOISE CONCERNS COMMUNITIES¹⁷

Noise can be defined as "unwanted sound", an audible acoustic energy that adversely affects the physiological and/or psychological well-being of people, or which disturbs or impairs the convenience or peace of any person. One can generalise by saying that sound becomes unwanted when it:

- Hinders speech communication;
- Impedes the thinking process;
- Interferes with concentration;
- Obstructs activities (work, leisure and sleeping); and
- Presents a health risk due to hearing damage.

However, it is important to remember that whether a given sound is "noise" depends on the listener or hearer. The driver playing loud rock music on their car radio hears no noise, but the person in the traffic behind them hears nothing but noise.

Response to noise is unfortunately not an empirical absolute, as it is seen as a multi-faceted psychological concept, including behavioural and evaluative aspects. For instance, in some cases annoyance is seen as an outcome of disturbances, in other cases it is seen as an indication of the degree of helplessness with respect to the noise source.

Noise does not need to be loud to be considered "disturbing". One can refer to a dripping tap in the quiet of the night, or the irritating "thump-thump" of the music from a neighbouring house at night when one would like to sleep.

Severity of the annoyance depends on factors such as:

- Background sound levels, and the background sound levels the receptor is used to;
- The manner in which the receptor can control the noise (helplessness);
- The time, unpredictability, frequency, distribution, duration, and intensity of the noise;
- The physiological state of the receptor; and
- The attitude of the receptor about the emitter (noise source).

4.2.1 Annoyance associated with Wind Energy Facilities¹⁸

Annoyance is the most widely acknowledged effect of environmental noise exposure, and is considered to be the most widespread. It is estimated that less than a third of the individual noise annoyance is accounted for by acoustic parameters, and that non-acoustic

¹⁷ World Health Organization, 1999; Noise quest, 2010; Journal of Acoustical Society of America, 2009

¹⁸ Van den Berg, 2011; Milieu, 2010.

factors plays a major role. Non-acoustic factors that have been identified include age, economic dependence on the noise source, attitude towards the noise source and self-reported noise sensitivity.

On the basis of a number of studies into noise annoyance, exposure-response relationships were derived for high annoyance from different noise sources. These relationships, illustrated in **Figure 4-1**, are recommended in a European Union position paper published in 2002, stipulating policy regarding the quantification of annoyance. This can be used in an Environmental Health Impact Assessment and cost-benefit analysis to translate noise maps into overviews of the numbers of persons that may be annoyed, thereby giving insight into the situation expected in the long term. It is not applicable to local complaint-type situations or to an assessment of the short-term effects of a change in noise climate.

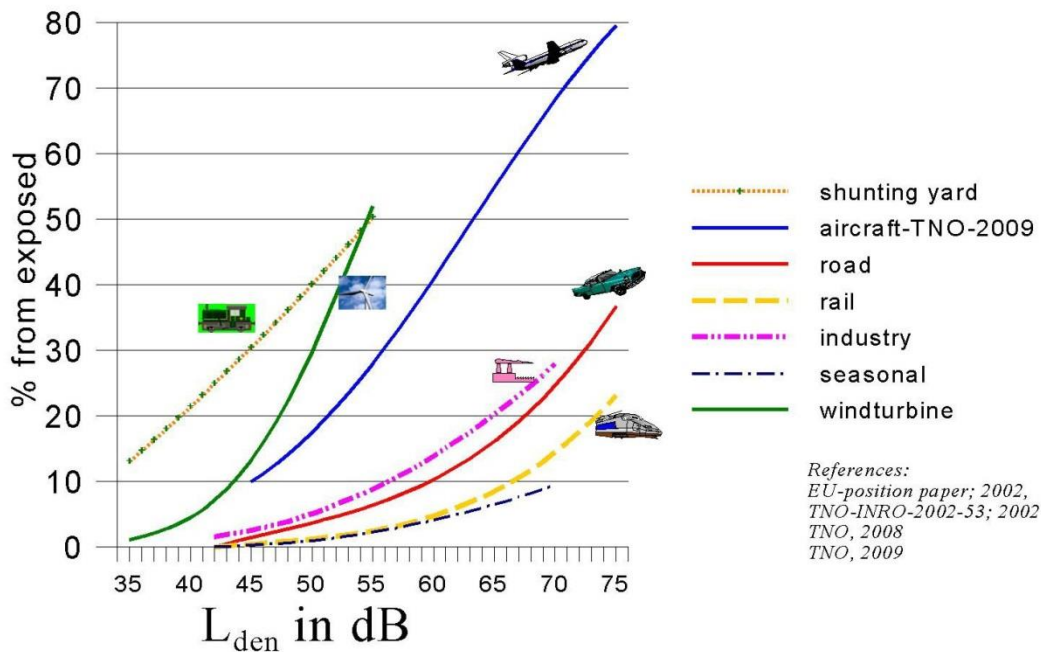

Figure 4-1: Percentage of annoyed persons as a function of the day-evening-night noise exposure at the façade of a dwelling

While the total ambient sound levels are of importance, the spectral characteristics also determines the likelihood that someone will hear external noises that may or may not be similar in spectral characteristics to that of vegetation created noise. Bolin (2006) did investigate spectral characteristics and determined the annoyance might occur at levels where noise generated by wind turbine noise exceeds natural ambient sounds with 3 dB or more.

4.3 IMPACT ASSESSMENT CRITERIA

4.3.1 Overview: The common characteristics

The word "noise" is generally used to convey a negative response or attitude to the sound received by a listener. There are four common characteristics of sound, any or all of which determine listener response and the subsequent definition of the sound as "noise". These characteristics are:

- Intensity;
- Loudness;
- Annoyance; and
- Offensiveness.

Of the four common characteristics of sound, intensity is the only one which is not subjective and can be quantified. Loudness is a subjective measure of the effect the sound has on the human ear. As a quantity it is therefore complicated but has been defined by experimentation on subjects known to have normal hearing.

The annoyance and offensive characteristics of noise are also subjective. Whether or not a noise causes annoyance mostly depends upon its reception by an individual, the environment in which it is heard, the type of activity and mood of the person and how acclimatised or familiar that person is to the sound.

4.3.2 Noise criteria of concern

The criteria used in this report were drawn from the criteria for the description and assessment of environmental impacts from the Integrated Environmental Management Information Series (DEAT, 2002).

There are a number of criteria that are of concern for the assessment of noise impacts. These can be summarised in the following manner:

- *Increase in noise levels:* People or communities often react to an increase in the ambient noise level they are used to, which is caused by a new source of noise. With regards to the NCRs, an increase of more than 7 dBA is considered a disturbing noise. See also **Figure 4-2**.
- *Zone Sound Levels:* Previously referred as the acceptable rating levels, sets acceptable noise levels for various areas. See also **Table 4-1**.
- *Absolute or total noise levels:* Depending on their activities, people generally are tolerant to noise up to a certain absolute level, e.g., 65 dBA. However, anything above this level is considered unacceptable.

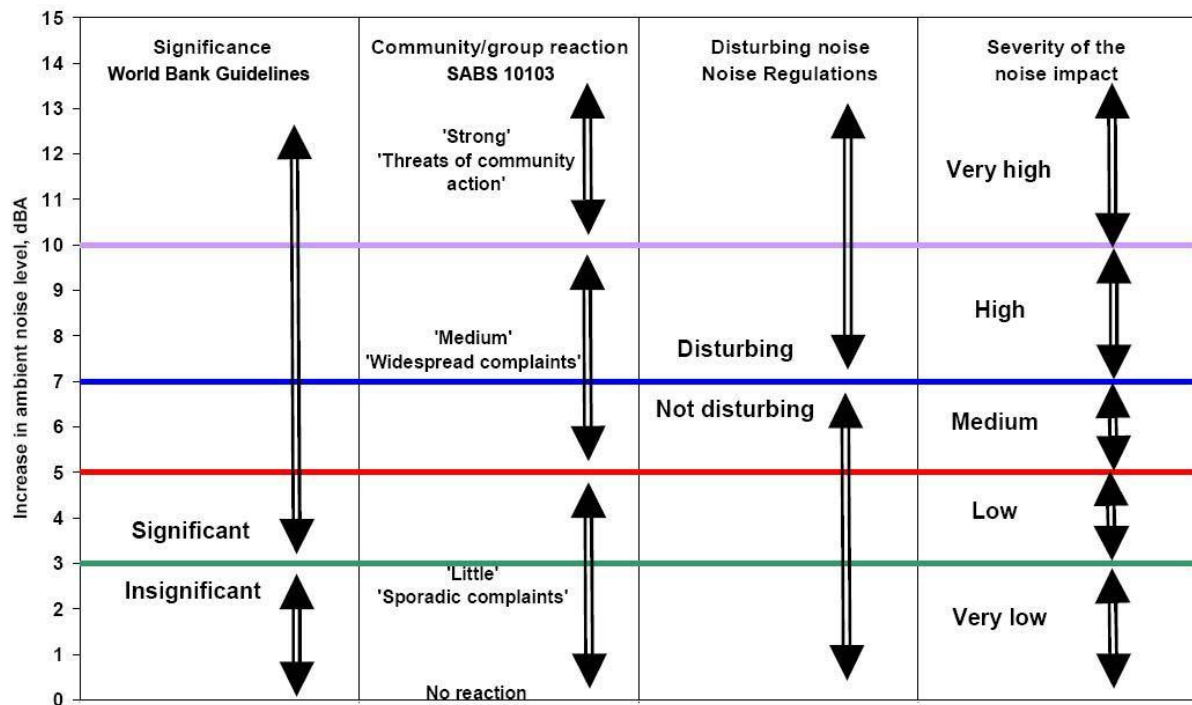

Figure 4-2: Criteria to assess the significance of impacts stemming from noise

In South Africa the document that addresses the issues concerning environmental noise is SANS 10103. See also **Table 4-1**. It provides the maximum average ambient noise levels, $L_{Req,d}$ and $L_{Req,n}$, during the day and night respectively to which different types of developments may be exposed. For rural areas the Zone Sound Levels (Rating Levels) are:

- Day (06:00 to 22:00) - $L_{Req,d} = 45$ dBA, and
- Night (22:00 to 06:00) - $L_{Req,n} = 35$ dBA.

SANS 10103 also provides a guideline for estimating community response to an increase in the general ambient noise level caused by an intruding noise. If Δ is the increase in noise level, the following criteria are of relevance:

- **$\Delta \leq 3$ dBA:** An increase of 3 dBA or less will not cause any response from a community. It should be noted that for a person with average hearing acuity an increase of less than 3 dBA in the general ambient noise level would not be noticeable.
- **$3 < \Delta \leq 5$ dBA:** An increase of between 3 dBA and 5 dBA will elicit 'little' community response with 'sporadic complaints'. People will just be able to notice a change in the sound character in the area.
- **$5 < \Delta \leq 15$ dBA:** An increase of between 5 dBA and 15 dBA will elicit a 'medium' community response with 'widespread complaints'. In addition, an increase of 10 dBA is subjectively perceived as a doubling in the loudness of a noise. For an

increase of more than 15 dBA the community reaction will be 'strong' with 'threats of community action'.

In addition, it should be noted that the NCRs defines disturbing noise to be any change in the ambient noise levels higher than 7 dBA than the background.

Table 4-1: Acceptable Zone Sound Levels for noise in districts (SANS 10103)

1	2	3	4	5	6	7
Type of district	Equivalent continuous rating level ($L_{Req,T}$) for noise dBA					
	Outdoors			Indoors, with open windows		
	Day/night $L_{R,dn}^a$	Daytime $L_{Req,d}^b$	Night-time $L_{Req,n}^b$	Day/night $L_{R,dn}^a$	Daytime $L_{Req,d}^b$	Night-time $L_{Req,n}^b$
a) Rural districts	45	45	35	35	35	25
b) Suburban districts with little road traffic	50	50	40	40	40	30
c) Urban districts	55	55	45	45	45	35
d) Urban districts with one or more of the following: workshops; business premises; and main roads	60	60	50	50	50	40
e) Central business districts	65	65	55	55	55	45
f) Industrial districts	70	70	60	60	60	50

4.3.3 Determining appropriate Zone Sound Levels

SANS 10103 unfortunately does not cater for instances when background noise levels change due to the impact of external forces. Locations close to the sea for instance always have a background noise level exceeding 35 dBA, and, in cases where the sea is rather turbulent, it can easily exceed 45 dBA. Similarly, noise induced by high winds is not included.

Setting noise limits relative to the background noise level is relatively straightforward when the prevailing background noise level and source level are constant. However, wind turbines emit noise that is related to wind speed, and the environment within which they are heard will probably also be dependent upon the strength of the wind and the noise associated with its effects. It is therefore necessary to derive a background noise level that is indicative of the noise environment at the receiving property for different wind speeds so that the turbine noise level at any particular wind speed can be compared with the background noise level in the same wind conditions.

4.3.3.1 Using International Guidelines to set Noise Limits

When assessing the overall noise levels emitted by a WEF, it is necessary to consider the full range of operating wind speeds of the wind turbines. This covers the wind speed range from around 3-5 m/s (the turbine cut-in wind speed) up to a wind speed range of 25-35 m/s measured at the hub height of a wind turbine. However, ETSU-R97 (1996) proposes that noise limits only be placed up to a wind speed of 12 m/s for the following reasons:

1. Wind speeds are not often measured at wind speeds greater than 12 m/s at 10 m height;
2. Reliable measurements of background ambient sound levels and turbine noise will be difficult to make in high winds due to the effects of wind noise on the microphone and the fact that one could have to wait several months before such winds were experienced;
3. Turbine manufacturers are unlikely to be able to provide information on sound power levels at such high wind speeds for similar reasons; and
4. If a wind farm meets noise limits at wind speeds lower than 12m/s, it is most unlikely to cause any greater loss of amenity at higher wind speeds. Turbine noise levels increase only slightly as wind speeds increase; however, background ambient sound levels increase significantly with increasing wind speeds due to the force of the wind.

Available data indicates that wind-induced noises start to increase at wind speeds 3 – 4 m/s, becoming a significant (and frequently the dominant noise source in rural areas) at wind speeds higher than 10 – 12 m/s/. Most wind turbines reach their maximum noise emission level at a wind speed of 8 – 10 m/s. At these wind speeds increased wind-induced noises (wind howling around building, rustling of leaves in trees, rattling noises, etc.) could start to drown other noises, including that being generated by wind turbines¹⁹.

Sound level vs. wind speed data is presented in the following figures (see from **Figure 4-3**)²⁰. It is based on approximately 30,000 measurements collected at various quiet locations in South Africa (locations further than 10 km from the ocean). Also indicated are around 480 actual night-time measurements collected within 10 km from the proposed WEF. There were no apparent or observable sounds that would have impacted on the measurements at these locations. There was a lack of higher wind speeds during previous site visits, but as with other sites, ambient sound levels are expected to increase as the

¹⁹ It should be noted that this does not mean that the wind turbines are inaudible.

²⁰ The sound level measuring instruments were located at a quiet location in the garden of the various houses. Data was measured in 10-minute bins and then co-ordinated with the 10 m wind speed derived from the wind mast of the developer. This wind mast was not close to the dwellings, being approximately 3,500m from the measurement locations.

surrounding wind speed increase. This has been found at all locations where measurements have been done for a sufficiently long enough period of time (more than 30 locations comprising of more than 38,000 measurements) with the data agreeing with a number of international studies on the subject.

Considering this data as well as the international guidelines (MOE, see **Table 2-1**; IFC, see **Table 2-2**), noise limits starting at 40 dB that increases to more than 45 dB (as wind speeds increase) could be acceptable. Project participants could be exposed to noise levels up to 45 dBA (ETSU-R97).

4.3.3.2 Using local regulations to set noise limits

Noise limits as set by the NCRs (GN 5479 of 20 August 1999 – **section 2.3.1**) defines a "**disturbing noise**" as the noise level that causes the ambient noise level to rise above the designated zone level, or if no zone level has been designated, the typical rating levels for ambient noise in districts, indicated in table 2 of SABS 0103. Accepting that the sound levels in the area may be typical of a sub-urban to urban noise district, the desired rating levels (see **section** □) would be 55 dBA for the daytime, and 45 dBA for the night-time period.

As can be observed from **Figure 4-3**²¹, if ambient sound levels were measured at increased wind speeds, ambient sound levels will be higher as wind-induced noises increase. Data collected during the site visit will be used to determine and motivate the acceptable zone sound level for the project, and the sound level data will also be used to estimate the probability for a noise impact to occur.

How wind-induced noises increase depends significantly on the measuring location and surrounding environment, but it is expected to be higher than 35 dBA closer to dwellings.

²¹ The sound level measuring instruments were located at a quiet location in the garden of the various houses. Data was measured in 10-minute bins and then co-ordinated with the 10 m wind speed derived from the wind mast of the developer. This wind mast normally was not close to the dwelling, at times being further than 5,000 meters from the measurement location. It is possible that the wind may be blowing at the location of the wind mast with no wind at the measurement location, resulting in low sound levels recorded.

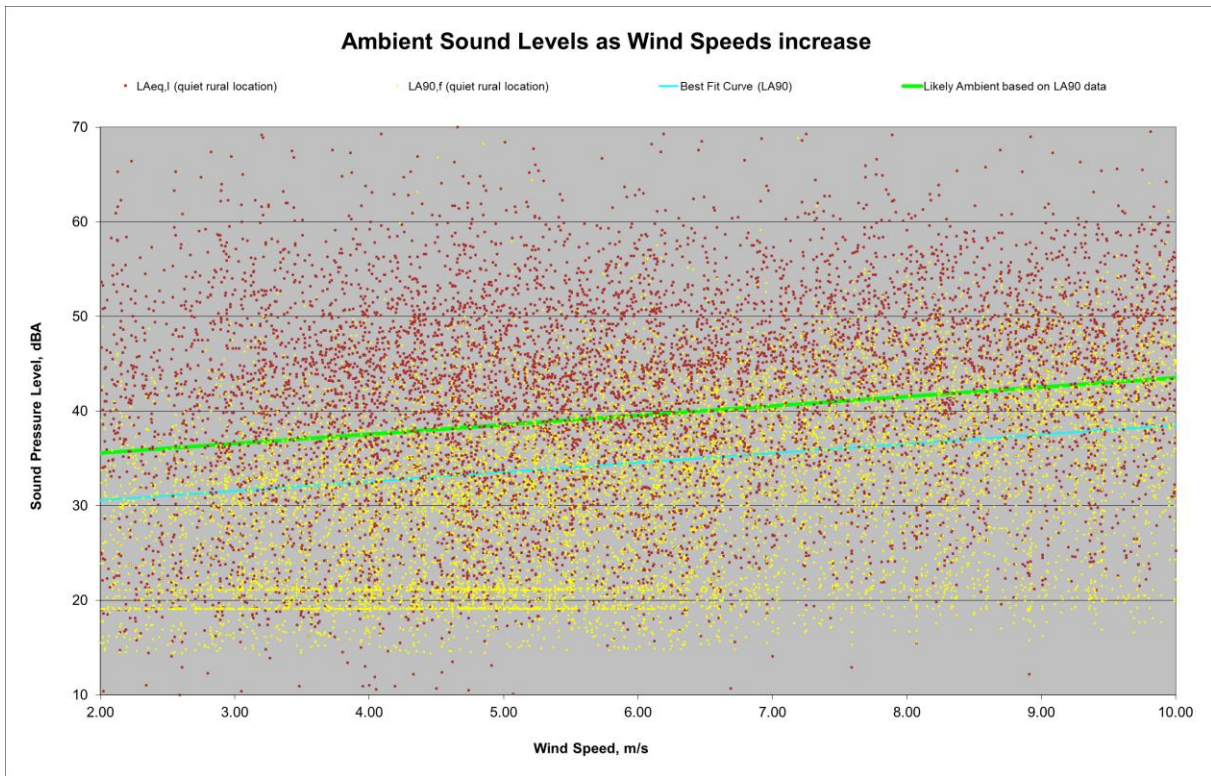

Figure 4-3: Ambient sound levels – quiet inland location (A-Weighted)

4.4 DETERMINING THE SCOPING SIGNIFICANCE OF THE NOISE IMPACT

Appendix 2 of GNR 982, as amended, requires the identification of the significance of potential impacts during scoping. To this end, an impact screening tool has been used in the scoping phase. The screening tool is based on two criteria, namely probability (**Table 4-2**); and, consequence (**Table 4-3**), where the latter is based on general consideration to the intensity, extent, and duration. The scales and descriptors used for scoring probability and consequence are detailed in **Table 4-4** and **Table 4-5** respectively.

Table 4-2: Probability Scores and Descriptors

SCORE	DESCRIPTOR
4	Definite: The impact will occur regardless of any prevention measures
3	Highly Probable: It is most likely that the impact will occur
2	Probable: There is a good possibility that the impact will occur
1	Improbable: The possibility of the impact occurring is very low

Table 4-3: Consequence Score Descriptions

SCORE	NEGATIVE	POSITIVE
4	Very severe: An irreversible and permanent change to the affected system(s) or party(ies) which cannot be mitigated.	Very beneficial: A permanent and very substantial benefit to the affected system(s) or party(ies), with no real alternative to achieving this benefit.
3	Severe: A long term impacts on the affected system(s) or party(ies) that could be mitigated. However, this mitigation would be difficult, expensive or time consuming or some combination of these.	Beneficial: A long term impact and substantial benefit to the affected system(s) or party(ies). Alternative ways of achieving this benefit would be difficult, expensive or time consuming, or some combination of these.
2	Moderately severe: A medium to long term impacts on the affected system(s) or party (ies) that could be mitigated.	Moderately beneficial: A medium to long term impact of real benefit to the affected system(s) or party(ies). Other ways of optimising the beneficial effects are equally difficult, expensive and time consuming (or some combination of these), as achieving them in this way.
1	Negligible: A short to medium term impacts on the affected system(s) or party(ies). Mitigation is very easy, cheap, less time consuming or not necessary.	Negligible: A short to medium term impact and negligible benefit to the affected system(s) or party(ies). Other ways of optimising the beneficial effects are easier, cheaper and quicker, or some combination of these.

Table 4-4: Significance Screening Tool

		CONSEQUENCE SCALE			
		1	2	3	4
PROBABILITY SCALE	1	Very Low	Very Low	Low	Medium
	2	Very Low	Low	Medium	Medium
	3	Low	Medium	Medium	High
	4	Medium	Medium	High	High

The nature of the impact must be characterised as to whether the impact is deemed to be positive (+ve) (i.e., beneficial) or negative (-ve) (i.e., harmful) to the receiving environment/receptor. For ease of reference, a colour reference system (**Table 4-5**) has been applied according to the nature and significance of the identified impacts.

Table 4-5: Impact Significance Colour Reference System to Indicate the Nature of the Impact

Negative Impacts (-ve)	Positive Impacts (+ve)
Negligible	Negligible
Very Low	Very Low
Low	Low
Medium	Medium
High	High

4.5 DETERMINING THE EIA SIGNIFICANCE OF THE NOISE IMPACT

The potential significance of the noise impact will be assessed during the future EIA phase, using the EIA criteria developed by the Author, considering the criteria of the EAP as well as the DEAT (CSIR, 2002) guideline. In order to establish a coherent framework within which all impacts could be objectively assessed, it will be necessary to establish a rating system, which will be applied consistently to all the criteria during the future ENIA specialist study.

The significance of the noise impact is determined by considering aspects such as:

- The Consequence (magnitude, severity or intensity) of the noise level;
- The Spatial Extent of the potential noise impact;
- The Reversibility of the potential impact;
- The Duration of the various project phases; and
- The Probability of the impact occurring.

5 RESULTS AND PRELIMINARY IMPACT ASSESSMENT

5.1 CONSTRUCTION PHASE

Projected construction noise impacts will only be modelled during the future EIA phase, considering a more final wind turbine layout. However, considering the location of the closest wind turbines in relation to the closest potential NSR, WTG construction activities may take place as close as 500 m from the closest NSR (NSR01, NSR02 and NSR11), not considering road construction activities.

As can be seen from **Table 3-1** and **Table 3-2**, noise levels could exceed 45 dBA²², higher than both the day- and night-time rating level (during low wind conditions) for a sub-urban noise district.

A potential alignments of access routes were not available during the scoping phase, and the potential impact associated with the construction of access roads (a temporary impact), as well as the influence of construction traffic passing NSR (potentially impact ambient sound levels in the short term), will only be considered during the future ENIA.

5.2 OPERATIONAL PHASE: ESTIMATED IMPACT AND IMPORTANT CONCEPTS

Projected operational noise impacts will only be modelled during the future EIA phase. However, considering the location of the closest wind turbines in relation to the closest potential NSR, operational activities may take place as close as 500 m from the closest NSR (NSR01, NSR02 and NSR11), with a definite cumulative effect at NSR01 (six WTG located within 1,500m from NSR01).

As can be seen from **Table 3-2**, the equivalent noise level will be higher than 45 dBA at the closest NSR (using the sound power emission level of 112.6 dBA re 1 pW), though the basic model does not consider the potential cumulative effects, the impact of atmospheric absorption, ground surface or topography. This noise level is higher than the proposed desired night-time rating level. The potential extent of noise from different WTG are also illustrated in **Figure 5-1**.

This however will be considered in more detail during the EIA phase, using a final wind turbines layout and using a detailed noise propagation model. A detailed noise propagation model can also consider cumulative noise impacts, as well as factors such as air absorption, character of the noise, surface factors and topography.

²² Depending on factors such as the number of simultaneous noise-generating activities as well as the sound power emission levels of the equipment

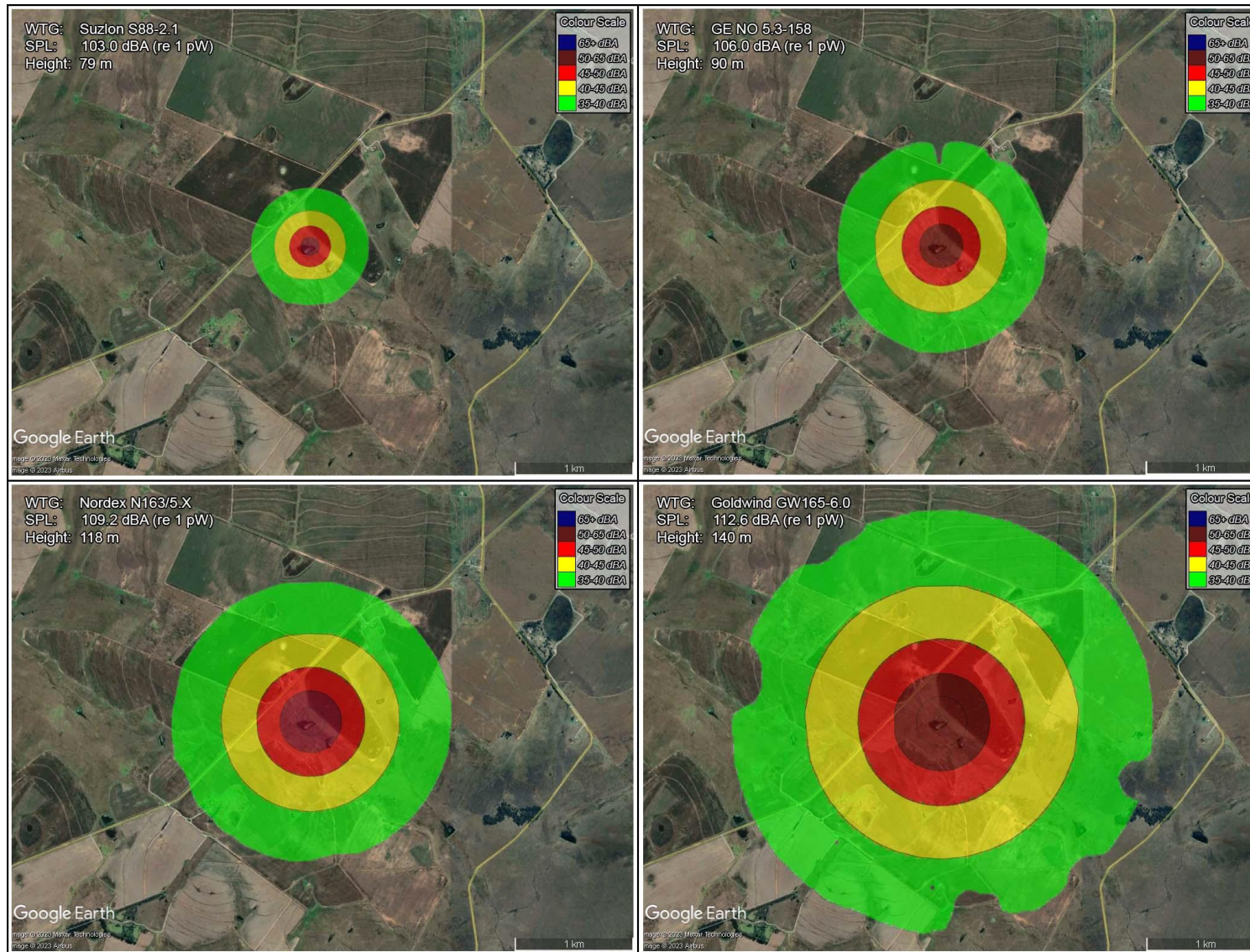

Figure 5-1: Extent of noises from different wind turbines (unmitigated, worst-case parameters)

6 PRELIMINARY SIGNIFICANCE OF THE NOISE IMPACT

6.1 CONSTRUCTION PHASE NOISE IMPACT

The impact assessment for the various activities defined in **Section 3.1** and assessed in **Section 5.1** that can create noise and may impact on the surrounding environment is summarized in the following **Table 6-1**.

Table 6-1: Scoping Level Noise Impact Assessment: Construction Activities

<p>Impacts: Increases in noise levels at closest receptors. Noise levels exceeding the SANS 10103 rating level.</p>			
<p>Desktop Sensitivity Analysis: Based on the daytime ambient sound level measurements, suburban to urban noise district, with a desired daytime $L_{R,d}$ rating level of 50 dBA. Based on the night-time ambient sound level measurements, suburban to urban noise district, with a desired night-time rating level of 40 to 45 dBA (depending on the distance from the N12 or R500 roads).</p>			
Issue	Nature of Impact	Extent of Impact	No-go areas
<p>Increase in noise level at receptors. Disturbing noises. Noises exceeding rating level.</p>	<p>Increased noises or disturbing noises may increase annoyance levels with project. Noise levels could exceed 45 dBA during construction. (temporary construction of access roads, construction of WTG as well as construction traffic passing close to NSR)</p>	<p>Multiple construction activities taking place simultaneously may impact an area up to 2,000m from the activities at night</p>	<p>As a preliminary guideline, construction activities within 160m from an identified and verified NSR is not recommended considering daytime noise limits (considering only construction noises). This buffer would be more considering night-time noise rating levels.</p>
<p>Description of expected significance of impact: Without noise propagation modeling where cumulative effects are included, it is difficult to assess the potential significance of the noise impact. Using the precautionous approach, it is <u>Possible</u> to <u>Highly Probable</u> that a noise impact will occur (depending on location of NSR), with the consequence likely <u>Negligible</u> to <u>Moderately Severe</u> (depending on location of NSR in relation to noise generating activities). Considering Table 4-4, the significance may be very low to medium at the different NSR. Construction noise impacts however:</p> <ul style="list-style-type: none"> (a) are highly reversible; (b) will not result in the irreplaceable loss of resources; and (c) potential noise impacts can be managed, mitigated or even avoided. <p>It should be noted that mitigation measures would be identified and recommended during the environmental noise impact assessment which would reduce the significance to low.</p>			
<p>Gaps in Knowledge & recommendation for further study: Insufficient information is available to consider the potential noise impact.</p>			
<p>Recommendations: Scoping level assessment is insufficient and a full ENIA is required.</p>			

6.2 OPERATIONAL PHASE NOISE IMPACT

The impact assessment for the various activities defined in **Section 3.2** and calculated in **section 5.2** will increase the ambient noise levels in the area. The noise impact is assessed and summarized in the following **Table 6-2**.

Table 6-2: Impact Assessment: Operational Activities

<p>Impacts: Increases in noise levels at closest receptors, though WTG will only operate during periods with increased wind speeds. The desired daytime ($L_{R,d}$ rating level of 55 dBA. Currently a suburban to urban noise district, with a desired night-time $L_{R,n}$ rating level of 45 dBA.</p>			
<p>Desktop Sensitivity Analysis: Rural area with night-time $L_{R,n}$ rating level of 35 dBA, although data indicate that noise levels increase as the wind speeds increase. Noise Limits will be recommended during the EIA phase.</p>			
Issue	Nature of Impact	Extent of Impact	No-go areas
Increase in noise level at receptors. Noises exceeding rating level.	Increased noises may increase annoyance levels with project.	Multiple wind turbines operating at night could impact on an area up to 2,000m from the turbines.	As the noise level depends on the layout (that would determine the cumulative effect from all wind turbines located within 2,000 m from an NSR) as well as the final WTG, no-go areas cannot be confirmed during the scoping phase.
<p>Description of expected significance of impact: The closest wind turbine is approximately 500 m from potential NSR and it is expected that the noise level will be higher than 45 dBA for a worst-case scenario (using the SPL of 112.6 dBA). There will be a cumulative noise impact from multiple WTG at the locations of NSR01, NSR02, NSR03, NSR11 and NSR12). Without noise propagation modeling where cumulative effects are included, it is difficult to assess the potential significance of the noise impact. Using the precautionous approach, it is <u>Probable</u> to <u>Highly Probable</u> that a noise impact will occur (depending on location of NSR), with the consequence likely <u>Moderately Severe</u> to <u>Severe</u> (depending on NSR). Considering Table 4-4, the significance may potentially be low to high at the different NSR. The potential significance of the noise impact will be assessed in more detail in EIA phase using a more detailed noise model. It should be noted that mitigation measures would be identified and recommended during the environmental noise impact assessment which would reduce the significance to low.</p>			
<p>Gaps in Knowledge & recommendation for further study: Insufficient information is available to consider the potential noise impact. A final wind turbine layout is required as well as the status of the identified NSR. The applicant should confirm the SPL of the potential noise source may be used at the WEF (or that should be evaluated).</p>			
<p>Recommendations: Scoping level assessment is insufficient and a full ENIA is recommended.</p>			

7 CONCLUSIONS AND RECOMMENDATIONS

This report is a Scoping assessment of the predicted noise environment due to the development of the Igolide WEF north-east of Fochville, Gauteng.

This assessment is based on a desktop assessment as well as a basic predictive model to identify potential issues of concern. Wind turbines do emit noises at sufficient levels to propagate over large distances and this assessment indicates a potential noise impact on the closest receptors.

Considering the preliminary wind turbine layout (which will be updated in response to specialist findings, resource and technical optimisation for the EIA Phase), there is a potential of a **low to medium** significance of a noise impact during the construction phase, and of a **low to high** significance during the operational phase on the different identified NSR. It should be noted that mitigation measures would be identified and recommended during the environmental noise impact assessment which would reduce the significance to low.

Further study is required and it is recommended that a full Environmental Noise Impact Assessment study be conducted for the Igolide WEF.

8 TERMS OF REFERENCE FOR THE ENVIRONMENTAL NOISE IMPACT PHASE

Work that will take place during the ENIA phase is defined in section 8 of SANS 10328:2008.

8.1 PURPOSE OF THE ENVIRONMENTAL NOISE IMPACT ASSESSMENT

The purpose of an environmental noise impact investigation and assessment is to determine and quantify the acoustical impact of, or on a proposed development.

8.2 PLAN OF STUDY FOR ENVIRONMENTAL NOISE IMPACT INVESTIGATION AND ASSESSMENT

In this regard the following will be included to assist the EAP in the compilation of the Plan of Study (PoS) for the EIA:

- Data (layout and SPL of selected WTG) as received from the developer will be used to model the potential noise impact. The following information will be considered:
 - The Sound Power Emission details of a WTG that may be used at this WEF;
 - The latest WEF layout to be assessed;
 - The surface contours of the project focus area;
 - Surface and meteorological constants;
- The potential impact will be evaluated (where possible) in terms of the nature (description of what causes the effect, what/who might be affected and how it/they might be affected) as well as the extent of the impact;
- The potential significance of the identified issues will be calculated based on the evaluation of the issues/impacts;
- The development of an Environmental Management Plan and a proposal of potential mitigation measures (if required); and
- Recommendations.

8.3 ENVIRONMENTAL NOISE IMPACT INVESTIGATION

8.3.1 Sound emission from the identified noise sources

Sound emission data as warranted by the wind turbine manufacturer would be used to calculate the potential noise emissions from the wind turbines. In the instance that this data is unavailable, sound emission data as measured and calculated in accordance with IEC 61400-11 (*Wind turbine generator systems – Part 11: Acoustic noise measurements*)

techniques) or IEC 61400-14 (*Wind turbines – Part 14: Declaration of apparent sound power levels and tonality values*) could be used.

The operating cycle and nature of the sound emission (impulsiveness, tonal character or potential low frequencies) would, where relevant, be considered when the expected rating level in the target area is calculated.

8.3.2 Determination of Rating levels

The sound propagation model defined by ISO 9613-2:1996 for both the construction and operational phases to calculate projected equivalent noise levels. Other input parameters used would include:

- Air temperature of 10 °C;
- Relative humidity of 70%;
- Appropriate ambient sound levels associated with a selected wind speed;
- Layout of the proposed facility as provided by the developer;
- Topography details;
- Height of turbine above sea level as well as height of wind turbine above surface level;
- Projected outside equivalent noise levels at Potentially Sensitive Receptors at height above sea-level (plus 4 meters for the operational phase, plus 2 m for the construction phase);
- 75% hard ground surface for the operational phase (medium ground surface for the construction phase).

8.3.3 Assessment of the noise impact: No mitigation

The significance will be determined considering the defined magnitude of the noise level, the extent as well as the duration of the projected noise impact, as well as the probability that this impact may take place.

The magnitude of the noise impact will be assessed by considering:

- The total projected cumulative noise level compared to the appropriate acceptable rating levels as defined in Table 2 of SANS 10103:2008;
- The potential community response from Table 5 of SANS 10103:2008. In addition, other relevant and suitable literature may be consulted as defined in the scoping report. In particular the likely ambient sound levels due to wind induced noises will be estimated at the wind speed under investigation and considered; and
- The likely and projected ambient sound levels.

Likely ambient sound levels associated with wind speeds as well as the projected change in ambient sound levels would also be considered when estimating the probability that a NSR may be impacted by increased noise levels.

8.3.4 Assessment of the noise impact: With Implementation of Mitigation

Should the significance of the impact be medium or high, the potential significance will be estimated considering that the developer would be implementing reasonable mitigation measures. Potential viable mitigation measures will be included.

8.4 ENVIRONMENTAL NOISE IMPACT REPORT

The Environmental Noise Impact Report will cover the following points:

- the purpose of the investigation;
- a brief description of the planned development or the changes that are being considered;
- a brief description of the existing environment including, where relevant, the topography, surface conditions and meteorological conditions during measurements;
- the identified noise sources together with their respective sound pressure levels or sound power levels (or both) and, where applicable, the operating cycles, the nature of sound emission, the spectral composition and the directional characteristics;
- the identified noise sources that were not taken into account and the reasons as to why they were not investigated;
- the identified Potentially Sensitive Receptors and the noise impact on them;
- where applicable, any assumptions, with references, made with regard to any calculations or determination of source and propagation characteristics;
- an explanation, either by a brief description or by reference, of all measuring and calculation procedures that were followed, as well as any possible adjustments to existing measuring methods that had to be made, together with the results of calculations;
- an explanation, either by description or by reference, of all measuring or calculation methods (or both) that were used to determine existing and predicted rating levels, as well as other relevant information, including a statement of how the data were obtained and applied to determine the rating level for the area in question;
- the location of measuring or calculating points in a sketch or on a map;
- quantification of the noise impact with, where relevant, reference to the literature consulted and the assumptions made;
- alternatives that were considered and the results of those that were investigated;

- a list of all the interested or affected parties that offered any comments with respect to the environmental noise impact investigation (if comments are received);
- a detailed summary of all the comments received from interested or affected parties as well as the procedures and discussions followed to deal with them (if comments are received);
- conclusions that were reached;
- proposed recommendations including potential mitigation measures;
- any follow-up investigation which should be conducted at completion of the project as well as at regular intervals after the commissioning of the project so as to ensure that the recommendations of this report will be maintained in the future.

9 REFERENCES

In this report reference was made to the following documentation:

1. Acoustics, 2008: *A review of the use of different noise prediction models for wind farms and the effects of meteorology*
2. Acoustics Bulletin, 2009: *Prediction and assessment of wind turbine noise*
3. Audiology Today, 2010: *Wind-Turbine Noise – What Audiologists should know*
4. Autumn, Lyn Radle, 2007: *The effect of noise on Wildlife: A literature review*
5. BWEA, 2005: *Low Frequency Noise and Wind Turbines – Technical Annex*
6. Bolin, Karl, 2006: *Masking of Wind Turbine Sound by Ambient Noise*. KTH Engineering Sciences
7. Bowdler, Dick, 2008: *Amplitude modulation of wind turbine noise: a review of the evidence*
8. DEAT, 2002: *Impact Significance, Integrated Environmental Management, Information Series 5*, Department of Environmental Affairs and Tourism (DEAT), Pretoria.
9. DEFRA, 2003: *A Review of Published Research on Low Frequency Noise and its Effects*, Report for Defra by Dr Geoff Leventhall Assisted by Dr Peter Pelmear and Dr Stephen Benton
10. DEFRA, 2007: *Research into Aerodynamic Modulation of Wind Turbine Noise: Final Report*
11. DELTA, 2008: *EFP-06 project: Low Frequency Noise from Large Wind Turbines, a procedure for evaluation of the audibility for low frequency sound and a literature study*, Danish Energy Authority
12. Delta, 2009: *Measurement of Noise Emission from a Vestas V90 3 MW wind turbine "Mode 0"*
13. Duncan, E. and Kaliski, K. 2008: *Propagation Modelling Parameters for Wind Power Projects*
14. ETSU R97: 1996. *'The Assessment and Rating of Noise from Wind Farms: Working Group on Noise from Wind Turbines'*
15. Fégeant, Olivier, 2002: *Masking of Wind Turbine Noise: Influence of wind turbulence on ambient noise fluctuations*. Royal Institute of Technology, Report 2002:12
16. HGC Engineering, 2006: *Wind Turbines and Infrasound*, report to the Canadian Wind Energy Association
17. HGC Engineering, 2007: *Wind Turbines and Sound*, report to the Canadian Wind Energy Association
18. ISO 9613-2: 1996. *'Acoustics – Attenuation of sound during propagation outdoors – Part 2: General method of calculation'*

19. Journal of Acoustical Society of America, 2009: *Response to noise from modern wind farms in the Netherlands*
20. Kamperman, GW. and James, RR, 2008: *The "How to" guide to siting wind turbines to prevent health risks from sound*
21. Milieu, 2010: *'Inventory of Potential Measures for a Better Control of Environmental Noise'*, DG Environment of the European Commission
22. Minnesota Department of Health, 2009: *Public Health Impacts of Wind Farms*
23. Ministry of the Environment, 2008: *Noise Guidelines for Wind Farms, Interpretation for Applying MOE NPC Publications to Wind Power Generation Facilities*
24. Noise-con, 2008: *Simple guidelines for siting wind turbines to prevent health risks*
25. Norton, M.P. and Karczub, D.G.: *Fundamentals of Noise and Vibration Analysis for Engineers*. Second Edition, 2003
26. SANS 10103:2008. 'The measurement and rating of environmental noise with respect to annoyance and to speech communication'.
27. SANS 10210:2004. 'Calculating and predicting road traffic noise'.
28. SANS 10328:2008. 'Methods for environmental noise impact assessments'.
29. SANS 10357:2004 The calculation of sound propagation by the Concave method'.
30. USEPA, 1971: *Effects of Noise on Wildlife and other animals*
31. Van den Berg, G.P., 2003. *Effects of the wind profile at night on wind turbine sound*. Journal of Sound and Vibration.
32. Van den Berg, G.P., 2004. *Do wind turbines produce significant low frequency sound levels?*. 11th International Meeting on Low Frequency Noise and Vibration and its Control
33. Van den Berg G.P., 2011. *Health based guidelines for wind turbine noise in the Netherlands: Fourth International Meeting on Wind Turbine Noise*.
34. Vestas, 2010: *'1/1 Octaves According to the General Specification – V90-1.8/2.0 MW'*. Denmark
35. Whitford, Jacques, 2008: *Model Wind Turbine By-laws and Best Practices for Nova Scotia Municipalities*
36. World Bank Group, 2015: *Environmental, Health, and Safety Guidelines Wind Energy*
37. World Health Organization, 2009: *Night Noise Guidelines for Europe*
38. World Health Organization, 1999: *Protection of the Human Environment; Guidelines for Community Noise*
39. World Health Organization, 2018: *Environmental Noise Guidelines for the European Region*

APPENDIX A

Curriculum Vitae

The Author started his career in the mining industry as a bursar Learner Official (JCI, Randfontein), working in the mining industry, doing various mining related courses (Rock Mechanics, Surveying, Sampling, Safety and Health [Ventilation, noise, illumination etc.] and Metallurgy. He did work in both underground (Coal, Gold and Platinum) as well as opencast (Coal) for 4 years. He changed course from Mining Engineering to Chemical Engineering after his second year of his studies at the University of Pretoria.

After graduation he worked as a Water Pollution Control Officer at the Department of Water Affairs and Forestry for two years (first year seconded from Wates, Meiring and Barnard), where duties included the perusal (evaluation, commenting and recommendation) of various regulatory required documents (such as EMPR's, Water Use License Applications and EIA's), auditing of license conditions as well as the compilation of Technical Documents.

Since leaving the Department of Water Affairs, Morné has been in private consulting for the last 20 years, managing various projects for the mining and industrial sector, private developers, business, other environmental consulting firms as well as the Department of Water Affairs. During that period he has been involved in various projects, either as specialist, consultant, trainer or project manager, successfully completing these projects within budget and timeframe. During that period he gradually moved towards environmental acoustics, focusing on this field exclusively since 2007.

He has been interested in acoustics as from school days, doing projects mainly related to loudspeaker design. Interest in the matter brought him into the field of Environmental Noise Measurement, Prediction and Control as well as blasting impacts. Since 2007 he has completed more than 300 Environmental Noise Impact Assessments, numerous Noise Monitoring Reports as well as various acoustic consulting services, including amongst others:

**Wind Energy
Facilities**

Full Environmental Noise Impact Assessments for - Bannf (Vidigenix), iNca Gouda (Aurecon SA), Isivunguvungu (Aurecon), De Aar (Aurecon), Kokerboom 1 (Aurecon), Kokerboom 2 (Aurecon), Kokerboom 3 (Aurecon), Kangnas (Aurecon), Plateau East and West (Aurecon), Wolf (Aurecon), Outeniqwa (Aurecon), Umsinde Emoyeni (ARCUS), Komsberg (ARCUS), Karee (ARCUS), Kolkies (ARCUS), San Kraal (ARCUS), Phezukomoya (ARCUS), Canyon Springs (Canyon Springs), Perdekraal (ERM), Scarlet Ibis (CESNET), Albany (CESNET), Sutherland (CSIR), Kap Vley (CSIR), Kuruman (CSIR), Rietrug (CSIR), Sutherland 2 (CSIR), Perdekraal (ERM), Teekloof (Mainstream), Eskom Aberdene (SE), Dorper (SE), Spreeukloof (SE), Loperberg (SE), Penhoek Pass (SE), Amakhala Emoyeni (SE), Zen (Savannah Environmental – SE), Goereesoe (SE), Springfontein (SE), Garob (SE), Project Blue (SE), ESKOM Kleinzee (SE), Namas (SE), Zonnequa (SE), Walker Bay (SE), Oyster Bay (SE), Hidden Valley (SE), Deep River (SE), Tsitsikamma (SE), AB (SE), West Coast One (SE), Hopefield II (SE), Namakwa Sands (SE), VentuSA Gouda (SE), Dorper (SE), Klipheuwel (SE), INCA Swellendam (SE), Cookhouse (SE), Iziduli (SE), Msenge (SE), Cookhouse II (SE), Rhebokfontein (SE), Suurplaat (SE), Karoo Renewables (SE), Koningaas (SE), Spitskop (SE), Castle (SE), Khai Ma (SE), Poortjies (SE), Korana (SE), IE Moorreesburg (SE), Gunstfontein (SE), Boulders (SE), Vredenburg (Terramanzi), Loeriesfontein

	<p>(SiVEST), Rhenosterberg (SiVEST), Noupoot (SiVEST), Prieska (SiVEST), Dwarsrug (SiVEST), Graskoppies (SiVEST), Philco (SiVEST), Hartebeest Leegete (SiVEST), Ithemba (SiVEST), IXha Boom (SiVEST), Spitskop West (Terramanzi), Haga Haga (Terramanzi), Vredenburg (Terramanzi), Msenge Emoyeni (Windlab), Wobben (IWP), Trakas (SiVest), Beaufort West (SiVest)</p>
<p>Mining and Industry</p>	<p>Full Environmental Noise Impact Assessments for – Delft Sand (AGES), BECSA – Middelburg (Golder Associates), Kromkrans Colliery (Geovicon Environmental), SASOL Borrow Pits Project (JMA Consulting), Lesego Platinum (AGES), Tweefontein Colliery (Cleanstream Environmental), Evraz Vametco Mine and Plant (JMA), Goedehoop Colliery (Geovicon), Hacra Project (Prescali Environmental), Der Brochen Platinum Project (J9 Environment), Brandbach Sand (AGES), Verkeerdepaa Extension (CleanStream Environmental), Dwaalboom Limestone (AGES), Jagdlust Chrome (MENCO), WPB Coal (MENCO), Landau Expansion (CleanStream Environmental), Otjikoto Gold (AurexGold), Klipfontein Colliery (MENCO), Imbabala Coal (MENCO), ATCOM East Expansion (Jones and Wagner), IPP Waterberg Power Station (SE), Kangra Coal (ERM), Schoongesicht (CleanStream Environmental), EastPlats (CleanStream Environmental), Chapudi Coal (Jacana Environmental), Generaal Coal (JE), Mopane Coal (JE), Glencore Boshhoek Chrome (JMA), Langpan Chrome (PE), Vlakpoort Chrome (PE), Sekoko Coal (SE), Frankford Power (REMIG), Strahrae Coal (Ferret Mining), Transalloys Power Station (Savannah), Pan Palladium Smelter, Iron and PGM Complex (Prescali Environmental), Fumani Gold (AGES), Leiden Coal (EIMS), Colenso Coal and Power Station (SiVEST/EcoPartners), Klippoortjie Coal (Gudani), Rietspruit Crushers (MENCO), Assen Iron (Tshikovha), Transalloys (SE), ESKOM Ankerlig (SE), Nooitgedacht Titano Project (EcoPartners), Algoa Oil Well (EIMS), Spitskop Chrome (EMAssistance), Vlakfontein South (Gudani), Leandra Coal (Jacana), Grazvalley and Zoetveld (Prescali), Tjate Chrome (Prescali), Langpan Chromite (Prescali), Vereeniging Recycling (Pro Roof), Meyerton Recycling (Pro Roof), Hammanskraal Billeting Plant 1 and 2 (Unica), Development of Altona Furnace, Limpopo Province (Prescali Environmental), Haakdoordrift Opencast at Amandelbult Platinum (Aurecon), Landau Dragline relocation (Aurecon), Stuart Coal Opencast (CleanStream Environmental), Tetra4 Gas Field Development (EIMS), Kao Diamonds – Tipping Village Relocation (EIMS), Kao Diamonds – West Valley Tailings Deposit (EIMS), Upington Special Economic Zone (EOH), Arcellor Mittal CCGT Project near Saldanha (ERM), Malawi Sugar Mill Project (ERM), Proposed Mooifontein Colliery (Geovicon Environmental), Goedehoop North Residue Deposit Expansion (Geovicon Environmental), Mutsho 600MW Coal-Fired Power Plant (Jacana Environmentals), Tshivhaso Coal-Fired Power Plant (Savannah Environmental), Doornhoek Fluorspar Project (Exigo), Royal Sheba Project (Cabanga Environmental), Rietkol Silica (Jacana), Gruisfontein Colliery (Jacana), Lehlabile Colliery (Jaco-K Consulting), Bloemendal Colliery (Enviro-Insight), Rondevly Colliery (REC), Welgedacht Colliery (REC), Kalabasfontein Extension (EIMS), Waltloo Power Generation Project (EScience), Buffalo Colliery (Marang), Balgarthen Colliery (Rayten), Kusipongo Block C (Rayten), Zandheuvel (Exigo), NamPower Walvis Bay (GPT), Eloff Phase 3 (EIMS), Dunbar (Enviro-Insight), Smokey Hills (Prescali), Bierspruit (Aurecon)</p>
<p>Road and Railway</p>	<p>K220 Road Extension (Urbansmart), Boskop Road (MTO), Sekoko Mining (AGES), Davel-Swaziland-Richards Bay Rail Link (Aurecon), Moloto Transport Corridor Status Quo Report and Pre-Feasibility (SiVEST), Postmasburg Housing Development (SE), Tshwane Rapid Transport Project, Phase 1 and 2 (NRM Consulting/City of Tshwane), Transnet Apies-river Bridge Upgrade (Transnet), Gautrain Due-diligence (SiVest), N2 Piet Retief (SANRAL), Atterbury Extension, CoT (Bokomoso Environmental), Riverfarm Development (Terramanzi), Conakry to Kindia Toll Road (Rayten)</p>
<p>Airport</p>	<p>Oudtshoorn Noise Monitoring (AGES), Sandton Heliport (Alpine Aviation), Tete Airport Scoping (Aurecon)</p>
<p>Noise monitoring and Audit Reports</p>	<p>Peerboom Colliery (EcoPartners), Thabametsi (Digby Wells), Doxa Deo (Doxa Deo), Harties Dredging (Rand Water), Xstrata Coal – Witbank Regional (Xstrata), Sephaku Delmas (AGES), Amakhala Emoyeni WEF (Windlab Developments), Oyster Bay WEF (Renewable Energy Systems), Tsitsikamma WEF Ambient Sound Level study (Cennergi and SE), Hopefield WEF (Umoya), Wesley WEF (Innowind), Ncora WEF (Innowind), Boschmanspoort (Jones and Wagner), Nqamakwe WEF (Innowind), Hopefield WEF Noise Analysis (Umoya), Dassiesfontein WEF Noise Analysis (BioTherm), Transnet Noise Analysis (Aurecon), Jeffries Bay Wind Farm (Globeleq), Sephaku Aganang (Exigo), Sephaku Delmas (Exigo), Beira Audit (BP/GPT), Nacala Audit (BP/GPT), NATREF (Nemai), Rappa Resources (Rayten), Measurement Report for Sephaku Delmas (Ages), Measurement Report for Sephaku Aganang (Ages), Bank of Botswana measurements (Linnspace), Skukuza Noise Measurements (Concor), Development noise measurement protocol for Mamba Cement (Exigo), Measurement Report for Mamba Cement (Exigo), Measurement Report for Nokeng Fluorspar (Exigo), Tsitsikamma Community Wind Farm Pre-operation sound measurements (Cennergi), Waainek WEF Operational Noise Measurements</p>

	<p>(Innowind), Sedibeng Brewery Noise Measurements (MENCO), Tsitsikamma Community Wind Farm Operational noise measurements (Cennerg), Noupoot Wind Farm Operational noise measurements (Mainstream), Twisdraai Colliery (Lefatshe Minerals), SASOL Prospecting (Lefatshe Minerals), South32 Klipspruit (Rayten), Sibanye Stillwater Kroondal (Rayten), Rooiberg Asphalt (Rooiberg Asphalt), SASOL Shondoni (Lefatshe), SASOL Twisdraai (Lefatshe), Anglo Mototolo (Exigo), Heineken Inyaniga (AECOM), Glencore Izimbiwa (Cleanstream) Glencore Impunzi (Cleanstream), Black Chrome Mine (Prescali) Sibanye Stillwater Ezulwini (Aurecon), Sibanye Stillwater Beatrix (Aurecon), Bank of Botswana (Linspace), Lakeside (Linspace), Skukuza (SiVest), Rietvlei Colliery (Jaco-K Consulting)</p>
<p>Small Noise Impact Assessments</p>	<p>TCTA AMD Project Baseline (AECOM), NATREF (Nemai Consulting), Christian Life Church (UrbanSmart), Kosmosdale (UrbanSmart), Louwlandia K220 (UrbanSmart), Richards Bay Port Expansion (AECOM), Babalegi Steel Recycling (AGES), Safika Slag Milling Plant (AGES), Arcelor Mittal WEF (Aurecon), RVM Hydroplant (Aurecon), Grootvlei PS Oil Storage (SiVEST), Rhenosterberg WEF, (SiVEST), Concerto Estate (BPTrust), Ekuseni Youth Centre (MENCO), Kranskop Industrial Park (Cape South Developments), Pretoria Central Mosque (Noman Shaikh), Soshanguve Development (Maluleke Investments), Seshego-D Waste Disposal (Enviroexcellence), Zambesi Safari Equipment (Owner), Noise Annoyance Assessment due to the Operation of the Gautrain (Thornhill and Lakeside Residential Estate), Uppington Solar (SE), Ilangaletu Solar (SE), Pofadder Solar (SE), Flagging Trees WEF (SE), Uyekraal WEF (SE), Ruuki Power Station (SE), Richards Bay Port Expansion 2 (AECOM), Babalegi Steel Recycling (AGES), Safika Ladium (AGES), Safika Cement Isando (AGES), RareCo (SE), Struisbaai WEF (SE), Perdekraal WEF (ERM), Kotula Tsatsi Energy (SE), Olievenhoutbosch Township (Nali), , HDMS Project (AECOM), Quarry extensions near Ermelo (Rietspruit Crushers), Proposed uMzimkhulu Landfill in KZN (nZingwe Consultancy), Linksfield Residential Development (Bokomoso Environmental), Rooihuiskraal Ext. Residential Development, CoT (Plandev Town Planners), Floating Power Plant and LNG Import Facility, Richards Bay (ERM), Floating Power Plant project, Saldanha (ERM), Vopak Growth 4 project (ERM), Elandsport Ext 3 Residential Development (Gibb Engineering), Tiegerpoort Wedding Venue (Henwood Environmental), Monavoni Development (Marindzini), Rezoning of Portion 1 (Primo Properties), Tswaing Mega City (Makole), Mabopane Church (EP Architects), ERGO Soweto Cluster (Kongiwe), Fabio Chains (Marang), GIDZ JMP (Marang), Temple Complex (KWP Create), Germiston Metals (Dorean), Sebenza Metals (Dorean)</p>
<p>Project reviews and amendment reports</p>	<p>Loperberg (Savannah), Dorper (Savannah), Penhoek Pass (Savannah), Oyster Bay (RES), Tsitsikamma Community Wind Farm Noise Simulation project (Cennerg), Amakhala Emoyeni (Windlab), Spreukloof (Savannah), Spinning Head (SE), Kangra Coal (ERM), West Coast One (Moyeng Energy), Rhebokfontein (Moyeng Energy), De Aar WEF (Holland), Quarterly Measurement Reports – Dangote Delmas (Exigo), Quarterly Measurement Reports – Dangote Lichtenburg (Exigo), Quarterly Measurement Reports – Mamba Cement (Exigo), Quarterly Measurement Reports – Dangote Delmas (Exigo) Quarterly Measurement Reports – Nokeng Fluorspar (Exigo), Proton Energy Limited Nigeria (ERM), Hartebeest WEF Update (Moorreesburg) (Savannah Environmental), Modderfontein WEF Opinion (Terramanzi), IPD Vredenburg WEF (IPD Power Vredenburg), Paul Puts WEF (ARCUS), Juno WEF (ARCUS), etc.</p>

Contact details for the Author are:

Author: Morné de Jager
 Company: Enviro-Acoustic Research cc
 Website: <http://www.eares.co.za>
 Email: morne@eares.co.za
 Office number: 012 004 0362
 Mobile number: 082 565 4059

APPENDIX B

Glossary of Terms

GLOSSARY OF ACOUSTIC TERMS, DEFINITIONS AND GENERAL INFORMATION

<i>1/3-Octave Band</i>	A filter with a bandwidth of one-third of an octave representing four semitones, or notes on the musical scale. This relationship is applied to both the width of the band, and the centre frequency of the band. See also definition of octave band.
<i>A – Weighting</i>	An internationally standardised frequency weighting that approximates the frequency response of the human ear and gives an objective reading that therefore agrees with the subjective human response to that sound.
<i>Air Absorption</i>	The phenomena of attenuation of sound waves with distance propagated in air, due to dissipative interaction within the gas molecules.
<i>Alternatives</i>	A possible course of action, in place of another, that would meet the same purpose and need (of proposal). Alternatives can refer to any of the following, but are not limited hereto: alternative sites for development, alternative site layouts, alternative designs, alternative processes and materials. In Integrated Environmental Management the so-called “no go” alternative refers to the option of not allowing the development and may also require investigation in certain circumstances.
<i>Ambient</i>	The conditions surrounding an organism or area.
<i>Ambient Noise</i>	The all-encompassing sound at a point being composed of sounds from many sources both near and far. It includes the noise from the noise source under investigation.
<i>Ambient Sound</i>	The all-encompassing sound at a point being composite of sounds from near and far.
<i>Ambient Sound Level</i>	Means the reading on an integrating impulse sound level meter taken at a measuring point in the absence of any alleged disturbing noise at the end of a total period of at least 10 minutes after such a meter was put into operation. In this report the term Background Ambient Sound Level will be used.
<i>Amplitude Modulated Sound</i>	A sound that noticeably fluctuates in loudness over time.
<i>Applicant</i>	Any person who applies for an authorisation to undertake a listed activity or to cause such activity in terms of the relevant environmental legislation.
<i>Assessment</i>	The process of collecting, organising, analysing, interpreting and communicating data that is relevant to some decision.
<i>Attenuation</i>	Term used to indicate reduction of noise or vibration, by whatever method necessary, usually expressed in decibels.
<i>Audible frequency Range</i>	Generally assumed to be the range from about 20 Hz to 20,000 Hz, the range of frequencies that our ears perceive as sound.
<i>Ambient Sound Level</i>	The level of the ambient sound indicated on a sound level meter in the absence of the sound under investigation (e.g., sound from a particular noise source or sound generated for test purposes). Ambient sound level as per Noise Control Regulations.
<i>Broadband Noise</i>	Spectrum consisting of a large number of frequency components, none of which is individually dominant.
<i>C-Weighting</i>	This is an international standard filter, which can be applied to a pressure signal or to a <i>SPL</i> or <i>PWL</i> spectrum, and which is essentially a pass-band filter in the frequency range of approximately 63 to 4000 Hz. This filter provides a more constant, flatter, frequency response, providing significantly less adjustment than the A-scale filter for frequencies less than 1000 Hz.
<i>Controlled area (as per National Noise Control Regulations)</i>	a piece of land designated by a local authority where, in the case of- (a) road transport noise in the vicinity of a road- (i) the reading on an integrating impulse sound level meter, taken outdoors at the end of a period extending from 06:00 to 24:00 while such meter is in operation, exceeds 65 dBA; or (ii) the equivalent continuous "A"-weighted sound pressure level at a height of at least 1,2 metres, but not more than 1,4 metres, above the

	<p>ground for a period extending from 06:00 to 24:00 as calculated in accordance with SABS 0210-1986, titled: "Code of Practice for calculating and predicting road traffic noise", published under Government Notice No. 358 of 20 February 1987, and projected for a period of 15 years following the date on which the local authority has made such designation, exceeds 65 dBA;</p> <p>(b) aircraft noise in the vicinity of an airfield, the calculated noisiness index, projected for a period of 15 years following the date on which the local authority has made such designation, exceeds 65 dBA; or</p> <p>(c) industrial noise in the vicinity of an industry-</p> <p>(i) the reading on an integrating impulse sound level meter, taken outdoors at the end of a period of 24 hours while such meter is in operation, exceeds 61 dBA; or</p> <p>(ii) the calculated outdoor equivalent continuous "A"-weighted sound pressure level at a height of at least 1,2 metres, but not more than 1,4 metres, above the ground for a period of 24 hours, exceeds 61 dBA;</p>
<i>dB(A)</i>	Sound Pressure Level in decibel that has been A-weighted, or filtered, to match the response of the human ear.
<i>Decibel (dB)</i>	A logarithmic scale for sound corresponding to a multiple of 10 of the threshold of hearing. Decibels for sound levels in air are referenced to an atmospheric pressure of 20 μ Pa.
<i>Diffraction</i>	The process whereby an acoustic wave is disturbed and its energy redistributed in space as a result of an obstacle in its path, Reflection and refraction are special cases of diffraction.
<i>Direction of Propagation</i>	The direction of flow of energy associated with a wave.
<i>Disturbing noise</i>	Means a noise level that exceeds the zone sound level or, if no zone sound level has been designated, a noise level that exceeds the ambient sound level at the same measuring point by 7 dBA or more.
<i>Environment</i>	The external circumstances, conditions and objects that affect the existence and development of an individual, organism or group; these circumstances include biophysical, social, economic, historical, cultural and political aspects.
<i>Environmental Control Officer</i>	Independent Officer employed by the applicant to ensure the implementation of the Environmental Management Plan (EMP) and manages any further environmental issues that may arise.
<i>Environmental impact</i>	A change resulting from the effect of an activity on the environment, whether desirable or undesirable. Impacts may be the direct consequence of an organisation's activities or may be indirectly caused by them.
<i>Environmental Impact Assessment</i>	An Environmental Impact Assessment (EIA) refers to the process of identifying, predicting and assessing the potential positive and negative social, economic and biophysical impacts of any proposed project, plan, programme or policy that requires authorisation of permission by law and that may significantly affect the environment. The EIA includes an evaluation of alternatives, as well as recommendations for appropriate mitigation measures for minimising or avoiding negative impacts, measures for enhancing the positive aspects of the proposal, and environmental management and monitoring measures.
<i>Environmental issue</i>	A concern felt by one or more parties about some existing, potential or perceived environmental impact.
<i>Equivalent continuous A-weighted sound exposure level ($L_{Aeq,T}$)</i>	The value of the average A-weighted sound pressure level measured continuously within a reference time interval T , which have the same mean-square sound pressure as a sound under consideration for which the level varies with time.
<i>Equivalent continuous A-weighted rating level ($L_{Req,T}$)</i>	The Equivalent continuous A-weighted sound exposure level ($L_{Aeq,T}$) to which various adjustments has been added. More commonly used as ($L_{Req,d}$) over a time interval 06:00 – 22:00 ($T=16$ hours) and ($L_{Req,n}$) over a time interval of 22:00 – 06:00 ($T=8$ hours). It is a calculated value.
<i>F (fast) time weighting</i>	(1) Averaging detection time used in sound level meters.

	(2) Fast setting has a time constant of 125 milliseconds and provides a fast reacting display response allowing the user to follow and measure not too rapidly fluctuating sound.
<i>Footprint area</i>	Area to be used for the construction of the proposed development, which does not include the total study area.
<i>Free Field Condition</i>	An environment where there is no reflective surfaces.
<i>Frequency</i>	The rate of oscillation of a sound, measured in units of Hertz (Hz) or kiloHertz (kHz). One hundred Hz is a rate of one hundred times per second. The frequency of a sound is the property perceived as pitch: a low-frequency sound (such as a bass note) oscillates at a relatively slow rate, and a high-frequency sound (such as a treble note) oscillates at a relatively high rate.
<i>Green field</i>	A parcel of land not previously developed beyond that of agriculture or forestry use; virgin land. The opposite of Greenfield is Brownfield, which is a site previously developed and used by an enterprise, especially for a manufacturing or processing operation. The term Brownfield suggests that an investigation should be made to determine if environmental damage exists.
<i>G-Weighting</i>	An International Standard filter used to represent the infrasonic components of a sound spectrum.
<i>Harmonics</i>	Any of a series of musical tones for which the frequencies are integral multiples of the frequency of a fundamental tone.
<i>I (impulse) time weighting</i>	(1) Averaging detection time used in sound level meters as per South African standards and Regulations. (2) Impulse setting has a time constant of 35 milliseconds when the signal is increasing (sound pressure level rising) and a time constant of 1,500 milliseconds while the signal is decreasing.
<i>Impulsive sound</i>	A sound characterized by brief excursions of sound pressure (transient signal) that significantly exceed the ambient sound level.
<i>Infrasound</i>	Sound with a frequency content below the threshold of hearing, generally held to be about 20 Hz. Infrasonic sound with sufficiently large amplitude can be perceived, and is both heard and felt as vibration. Natural sources of infrasound are waves, thunder and wind.
<i>Integrated Development Plan</i>	A participatory planning process aimed at developing a strategic development plan to guide and inform all planning, budgeting, management and decision-making in a Local Authority, in terms of the requirements of Chapter 5 of the Municipal Systems Act, 2000 (Act 32 of 2000).
<i>Integrated Environmental Management</i>	IEM provides an integrated approach for environmental assessment, management, and decision-making and to promote sustainable development and the equitable use of resources. Principles underlying IEM provide for a democratic, participatory, holistic, sustainable, equitable and accountable approach.
<i>Interested and affected parties</i>	Individuals or groups concerned with or affected by an activity and its consequences. These include the authorities, local communities, investors, work force, consumers, environmental interest groups and the general public.
<i>Key issue</i>	An issue raised during the Scoping process that has not received an adequate response and that requires further investigation before it can be resolved.
<i>L_{A90}</i>	the sound level exceeded for the 90% of the time under consideration
<i>Listed activities</i>	Development actions that is likely to result in significant environmental impacts as identified by the delegated authority (formerly the Minister of Environmental Affairs and Tourism) in terms of Section 21 of the Environment Conservation Act.
<i>L_{AMin} and L_{AMax}</i>	Is the RMS (root mean squared) minimum or maximum level of a noise source.
<i>Loudness</i>	The attribute of an auditory sensation that describes the listener's ranking of sound in terms of its audibility.
<i>Magnitude of impact</i>	Magnitude of impact means the combination of the intensity, duration and extent of an impact occurring.
<i>Masking</i>	The raising of a listener's threshold of hearing for a given sound due to the presence of another sound.
<i>Mitigation</i>	To cause to become less harsh or hostile.

<i>Negative impact</i>	A change that reduces the quality of the environment (for example, by reducing species diversity and the reproductive capacity of the ecosystem, by damaging health, or by causing nuisance).
<i>Noise</i>	a. Sound that a listener does not wish to hear (unwanted sounds). b. Sound from sources other than the one emitting the sound it is desired to receive, measure or record. c. A class of sound of an erratic, intermittent or statistically random nature.
<i>Noise Level</i>	The term used in lieu of sound level when the sound concerned is being measured or ranked for its undesirability in the contextual circumstances.
<i>Noise-sensitive development</i>	developments that could be influenced by noise such as: a) districts (see table 2 of SANS 10103:2008) 1. rural districts, 2. suburban districts with little road traffic, 3. urban districts, 4. urban districts with some workshops, with business premises, and with main roads, 5. central business districts, and 6. industrial districts; b) educational, residential, office and health care buildings and their surroundings; c) churches and their surroundings; d) auditoriums and concert halls and their surroundings; e) recreational areas; and f) nature reserves. In this report Noise-sensitive developments is also referred to as a Potential Sensitive Receptor
<i>Octave Band</i>	A filter with a bandwidth of one octave, or twelve semi-tones on the musical scale representing a doubling of frequency.
<i>Positive impact</i>	A change that improves the quality of life of affected people or the quality of the environment.
<i>Property</i>	Any piece of land indicated on a diagram or general plan approved by the Surveyor-General intended for registration as a separate unit in terms of the Deeds Registries Act and includes an erf, a site and a farm portion as well as the buildings erected thereon
<i>Public Participation Process</i>	A process of involving the public in order to identify needs, address concerns, choose options, plan and monitor in terms of a proposed project, programme or development
<i>Reflection</i>	Redirection of sound waves.
<i>Refraction</i>	Change in direction of sound waves caused by changes in the sound wave velocity, typically when sound wave propagates in a medium of different density.
<i>Reverberant Sound</i>	The sound in an enclosure which results from repeated reflections from the boundaries.
<i>Reverberation</i>	The persistence, after emission of a sound has stopped, of a sound field within an enclosure.
<i>Significant Impact</i>	An impact can be deemed significant if consultation with the relevant authorities and other interested and affected parties, on the context and intensity of its effects, provides reasonable grounds for mitigating measures to be included in the environmental management report. The onus will be on the applicant to include the relevant authorities and other interested and affected parties in the consultation process. Present and potential future, cumulative and synergistic effects should all be taken into account.
<i>S (slow) time weighting</i>	(1) Averaging times used in sound level meters. (2) Time constant of one [1] second that gives a slower response which helps average out the display fluctuations.
<i>Sound Level</i>	The level of the frequency and time weighted sound pressure as determined by a sound level meter, i.e., A-weighted sound level.
<i>Sound Power</i>	Of a source, the total sound energy radiated per unit time.
<i>Sound Pressure Level (SPL)</i>	Of a sound, 20 times the logarithm to the base 10 of the ratio of the RMS sound pressure level to the reference sound pressure level. International values for the reference sound pressure level are 20 micro pascals in air and 100

	millipascals in water. SPL is reported as L_p in dB (not weighted) or in various other weightings.
<i>Soundscape</i>	Sound or a combination of sounds that forms or arises from an immersive environment. The study of soundscape is the subject of acoustic ecology. The idea of soundscape refers to both the natural acoustic environment, consisting of natural sounds, including animal vocalizations and, for instance, the sounds of weather and other natural elements; and environmental sounds created by humans, through musical composition, sound design, and other ordinary human activities including conversation, work, and sounds of mechanical origin resulting from use of industrial technology. The disruption of these acoustic environments results in noise pollution.
<i>Study area</i>	Refers to the entire study area encompassing all the alternative routes as indicated on the study area map.
<i>Sustainable Development</i>	Development that meets the needs of the present without compromising the ability of future generations to meet their own needs. It contains within it two key concepts: the concept of "needs", in particular the essential needs of the world's poor, to which overriding priority should be given; and the idea of limitations imposed by the state of technology and social organization on the environment's ability to meet present and the future needs (Brundtland Commission, 1987).
<i>Tread braked</i>	The traditional form of wheel brake consisting of a block of friction material (which could be cast iron, wood or nowadays a composition material) hung from a lever and being pressed against the wheel tread by air pressure (in the air brake) or atmospheric pressure in the case of the vacuum brake.
<i>Zone of Potential Influence</i>	The area defined as the radius about an object, or objects beyond which the noise impact will be insignificant.
<i>Zone Sound Level</i>	Means a derived dBA value determined indirectly by means of a series of measurements, calculations or table readings and designated by a local authority for an area. This is similar to the Rating Level as defined in SANS 10103:2008.

APPENDIX C

Preliminary Site Sensitivity Verification

SITE SENSITIVITY VERIFICATION (IN TERMS OF PART A OF THE ASSESSMENT PROTOCOLS PUBLISHED IN GN 320 ON 20 MARCH 2020

Part A of the Assessment Protocols published in GN 320 on 20 March 2020 (i.e. Site sensitivity verification is required where a specialist assessment is required but no specific assessment protocol has been prescribed) is applicable where the Department of Forestry, Fisheries and Environment Screening Tool has the relevant themes to verify.

A site sensitivity verification was undertaken in accordance with Part A of GNR 320 of 20 March 2020 prior to commencing with the Noise Specialist Assessment. The site sensitivity verification is completed as per Appendix 6 of the 2014 NEMA EIA Regulations (as amended), that defines site sensitivity verification requirements where a Specialist Assessment is required. This is completed to confirm the current land use and environmental sensitivity of the proposed project area as identified by the National Web-Based Environmental Screening Tool (Screening Tool).

The details of the specialists that completed the site sensitivity verification are noted below:

Date of Site Visit	3 to 9 May 2023
Specialist Name	Morné de Jager / Francois de Vries
Professional Registration Number (if applicable)	Not applicable, there is no registration body in South Africa that could allow professional registration for acoustic consultants.
Specialist Affiliation / Company	Enviro-Acoustic Research CC

Output from National Environmental Screening Tool

The site was initially assessed using the National Environmental Screening tool, available at, <https://screening.environment.gov.za>. The output from the National Online Screening tool indicates a number of areas within, and up to 2,000 m from the project boundary is considered to be of a “very high” sensitivity to noise. These potentially “very high” sensitive areas (in terms of noise) are indicated on **Figure D.1** together with the potential noise-sensitive receptors as identified using available aerial images.

Description on how the site sensitivity verification was undertaken

The site sensitivity was confirmed using:

- a) available aerial images (Google Earth®) (See **Figure C.1** for verified potential noise-sensitive receptors);*
- b) the structures are used for residential purposes and noise sensitive.*



Figure C.1: Areas defined to be of "Very High" sensitivity in terms of noise by the online screening tool

Outcome of the Site Sensitivity Verification

- 1. The online screening tool identified a number of areas that may have a "very high" sensitivity to noise; and*
- 2. The desktop assessment identified a number of potentially noise-sensitive receptors within the areas identified to have a "very high" sensitivity to noise by the online screening tool.*

Due to the number of potential noise-sensitive locations in the area, it is recommended that the potential significance of the noise impact be assessed on the verified receptors in a noise specialist study.

Signature

Morné de Jager

2023 – 06 – 14