

**TYPE A** GLAZED AREA : 1,95m<sup>2</sup>

Window No. : **W01** Quantity : 1  
 Location : Living Room / North Elevation  
 Description : Powder coated aluminum casement window & fixed panes  
 Glazing : 6,0mm toughened safety glass to bottom fixed panes & 5,0mm monolithic annealed glass to casement windows

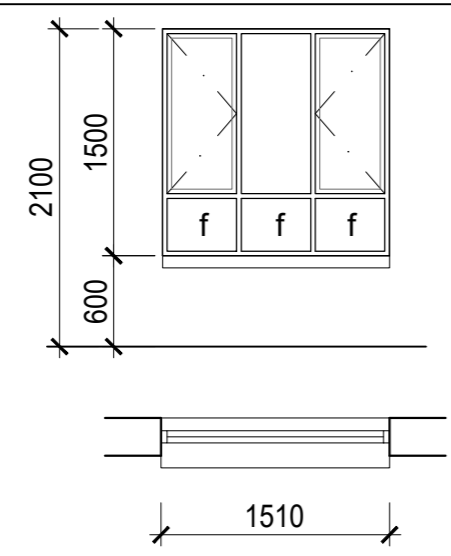

**TYPE B** GLAZED AREA : 1,74m<sup>2</sup>

Window No. : **W02** Quantity : 1  
 Location : Dining Room / North Elevation  
 Description : Powder coated aluminum casement window & fixed panes  
 Glazing : 6,0mm toughened safety glass to bottom fixed panes & 5,0mm monolithic annealed glass to casement windows

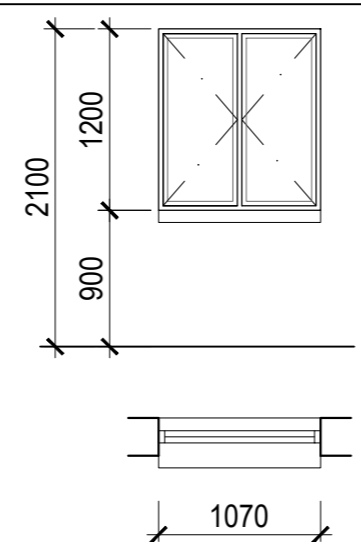

**TYPE C** GLAZED AREA : 0,92m<sup>2</sup>

Window No. : **W03** Quantity : 1  
 Location : Kitchen / North Elevation  
 Description : Powder coated aluminum casement window  
 Glazing : 6,0mm toughened safety glass

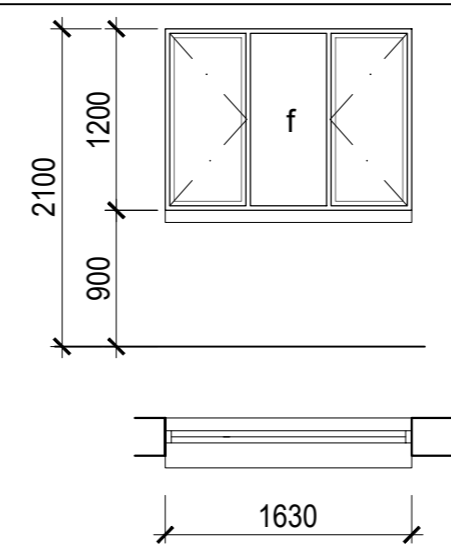

**TYPE D** GLAZED AREA : 1,51m<sup>2</sup>

Window No. : **W04** Quantity : 1  
 Location : Kitchen / North Elevation  
 Description : Powder coated aluminum casement window & fixed pane  
 Glazing : 6,0mm toughened safety glass

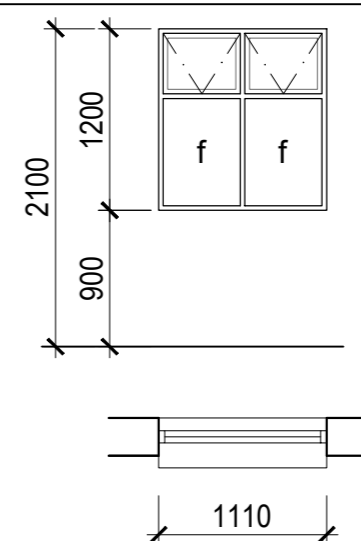

**TYPE E** GLAZED AREA : 1,02m<sup>2</sup>

Window No. : **W05** Quantity : 1  
 Location : Bathroom / North Elevation  
 Description : Powder coated aluminum project out windows  
 Glazing : 6,0mm toughened safety glass to fixed pane & 4,0mm monolithic annealed glass project out windows

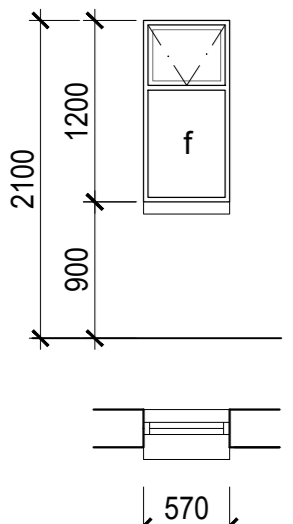

**TYPE F** GLAZED AREA : 0,51m<sup>2</sup>

Window No. : **W06** Quantity : 1  
 Location : WC / North Elevation  
 Description : Powder coated aluminum project out window  
 Glazing : 6,0mm toughened safety glass to fixed pane & 4,0mm monolithic annealed glass project out window

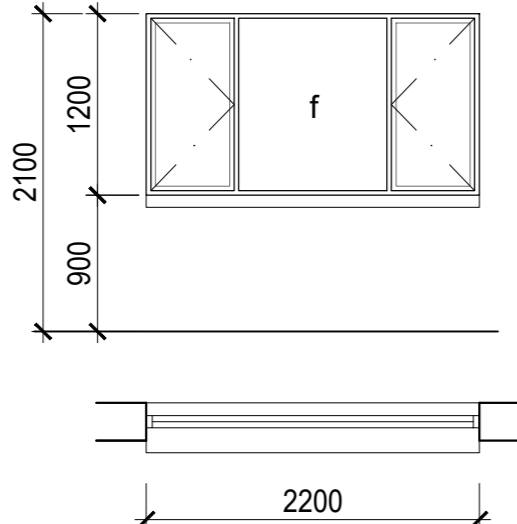

**TYPE G** AREA : 2,14m<sup>2</sup>

Window No. : **W07** Quantity : 1  
 Location : TV Lounge / North Elevation  
 Description : Powder coated aluminum casement window & fixed light  
 Glazing : 5,0mm monolithic annealed glass

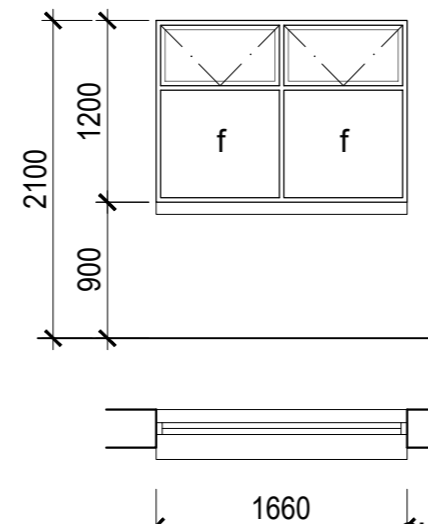

**TYPE H** GLAZED AREA : 1,58m<sup>2</sup>

Window No. : **W08** Quantity : 1  
 Location : En Suite / North Elevation  
 Description : Powder coated aluminum project out windows  
 Glazing : 6,0mm toughened safety glass to fixed panes & 4,0mm monolithic annealed glass to top opening windows

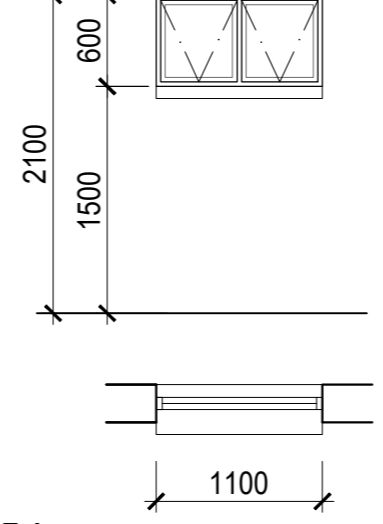

**TYPE J** GLAZED AREA : 0,42m<sup>2</sup>

Window No. : **W09,W10** Quantity : 2  
 Location : Master Bedroom / West Elevation  
 Description : Powder coated aluminum project out windows  
 Glazing : 4,0mm monolithic annealed glass.

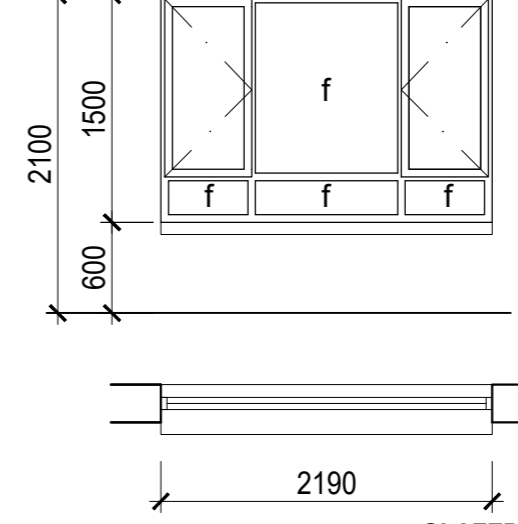

**TYPE K** GLAZED AREA : 2,45m<sup>2</sup>

Window No. : **W11,W12,W13** Quantity : 3  
 Location : Master Bedroom, Bedrooms 01 & 02 South Elevation  
 Description : Powder coated alum. casement window & fixed panes  
 Glazing : 6,0mm toughened safety glass to bottom fixed panes & 5,0mm monolithic annealed glass to casement windows

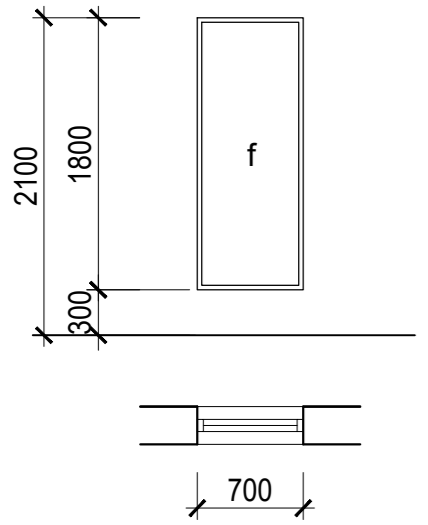

**TYPE L** GLAZED AREA : 1,1m<sup>2</sup>

Window No. : **W14** Quantity : 1  
 Location : Living Room / South Elevation  
 Description : Powder coated aluminum fixed pane  
 Glazing : 6,0mm toughened safety glass

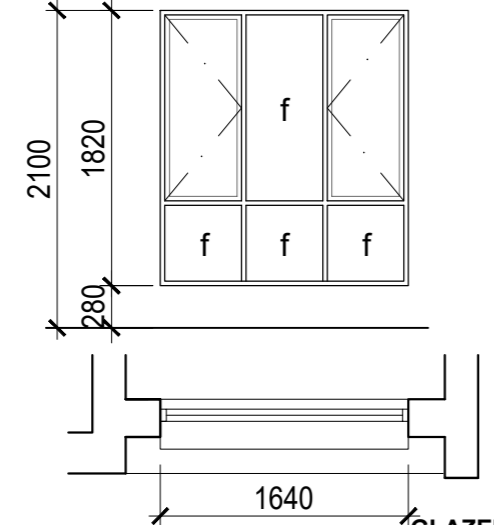

**TYPE M** GLAZED AREA : 2,41m<sup>2</sup>

Window No. : **W15** Quantity : 1  
 Location : Living Room / South Elevation  
 Description : Powder coated aluminum casement window & fixed panes  
 Glazing : 6,0mm toughened safety glass to bottom fixed panes & 5,0mm monolithic annealed glass casement windows

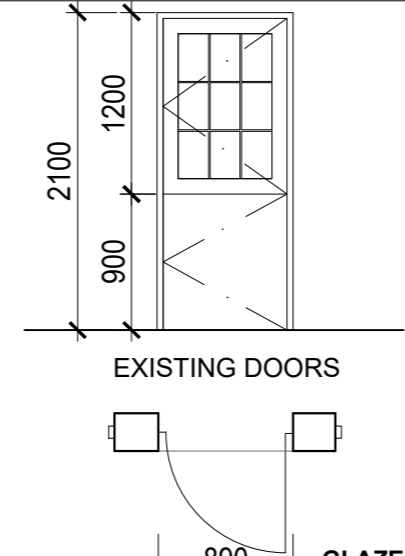

**TYPE P** GLAZED AREA : 0,5m<sup>2</sup>

Door No. : **D01** Quantity : 1  
 Location : Kitchen / North Elevation  
 Description : Existing Cottage pane stable door

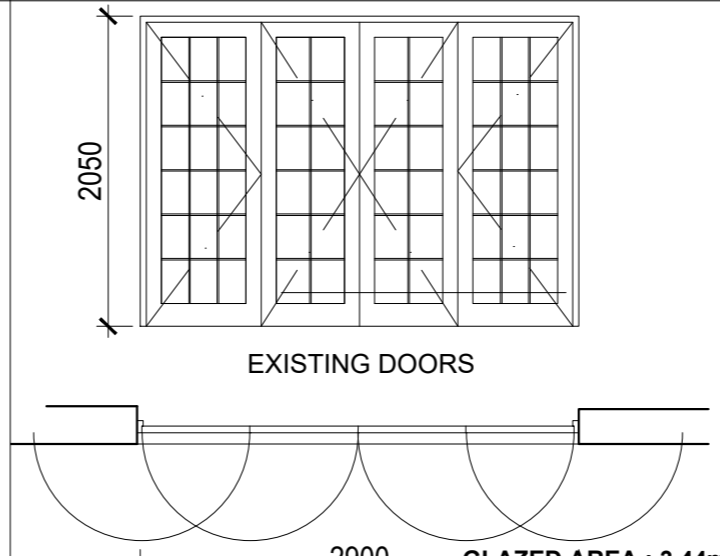

**TYPE N** GLAZED AREA : 3,44m<sup>2</sup>

Door No. : **D02, D03** Quantity : 2  
 Location : Living Room & Dining Room / South Elevation  
 Description : Existing Cottage pane folding doors

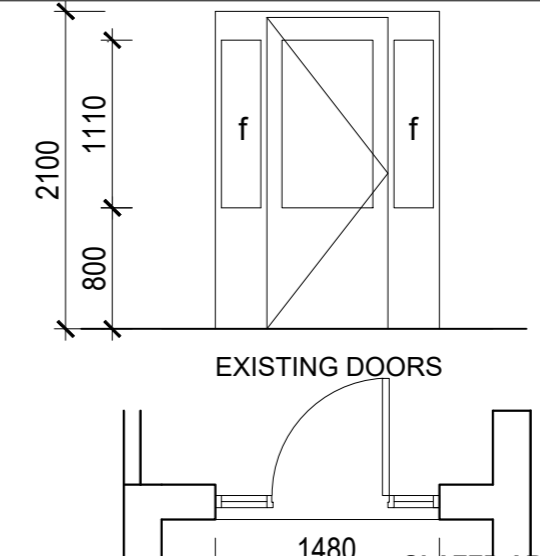

**TYPE Q** GLAZED AREA : 1,22m<sup>2</sup>

Door No. : **D04** Quantity : 1  
 Location : Entrance Hall / South Elevation  
 Description : Existing glazed door with fixed side lights

WINDOW NOTE: Existing Timber windows replaced with Powder coated aluminum windows  
 Glazing to comply with SANS 10400 Part N 4,1 & 4,2

**WINDOW GLAZED AREA**

Window No.	Glazed Area (m <sup>2</sup> )
W01	1,95m <sup>2</sup>
W02	1,74m <sup>2</sup>
W03	0,92m <sup>2</sup>
W04	1,51m <sup>2</sup>
W05	1,02m <sup>2</sup>
W06	0,51m <sup>2</sup>
W07	2,14m <sup>2</sup>
W08	1,58m <sup>2</sup>
W09	0,42m <sup>2</sup>
W10	0,42m <sup>2</sup>
W11	2,45m <sup>2</sup>
W12	2,45m <sup>2</sup>
W13	2,45m <sup>2</sup>
W14	1,1m <sup>2</sup>
W15	2,41m <sup>2</sup>
<b>TOTAL</b>	<b>24,6m<sup>2</sup></b>

**EXISTING DOORS**

Door No.	Area (m <sup>2</sup> )
D01	0,5m <sup>2</sup>
D02	3,44m <sup>2</sup>
D03	3,44m <sup>2</sup>
D04	1,22m <sup>2</sup>
<b>TOTAL</b>	<b>8,6m<sup>2</sup></b>
	<b>33,2m<sup>2</sup></b>

Ground Storey Floor Area 250,0m<sup>2</sup>  
 Glazing percentage 13,28%

GLAZING AREA IS LESS THAN 15% OF FLOOR AREA

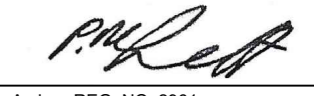
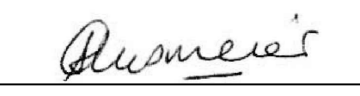
ARCHITECT  
  
 PATRICIA EMMETT Pr. Arch. - REG. NO. 2961  
 OWNER  

PROJECT:  
**38 St. KILDA AVENUE**  
**MINOR ALTERATIONS**  
**(NEW WINDOWS) TO RESIDENCE**  
 for  
**Susan Carol Ausmeier**  
 on Portion 54 of Erf 935 Durban North

**WINDOW & DOOR SCHEDULE**

SCALE - 1:50  
 DATE - 12-11-2021  
 DWG. No. - 02114 / 02  
 REV. No -

  
**ARCHITECTS**  
 362 LILIAN NGOYI (WINDERMERE) ROAD, DURBAN 4001.  
 TEL (031) 312 6498, FAX (031) 303 5229 E-MAIL emmettarc@gmail.com

C:\Users\User\Documents\2021\38 St. Kilda Avenue\St. Kilda Avenue - Deviation Plans.dwg