

REPORT N° 01

PROPOSED ENAMANDLA PV 5 PROJECT

DRAFT ENVIRONMENTAL SCOPING REPORT

CONFIDENTIAL

SEPTEMBER 2016

PROPOSED ENAMANDLA PV 5 PROJECT

DRAFT ENVIRONMENTAL SCOPING REPORT

BioTherm Energy (Pty) Ltd

Type of document (version)
Confidential

Project no: 47579
Date: September 2016

—
WSP | Parsons Brinckerhoff
199 Bryanston Drive
Bryanston, 2191

Tel: +27 11 361 1392
Fax: +27 11 361 1381
www.wspgroup.com
www.pbworld.com

QUALITY MANAGEMENT

ISSUE/REVISION	FIRST ISSUE	REVISION 1	REVISION 2	REVISION 3
Remarks	Draft ESR – Enamandla PV 5			
Date	September 2016			
Prepared by	Bronwyn Fisher			
Signature				
Checked by	Ashlea Strong			
Signature				
Authorised by	Nigel Seed			
Signature				
Project number	47579			
Report number	1			
File reference	W:\000 NEW Projects\47579 - Biotherm\42 ES\2-REPORTS\4-Scoping\05-Enamandla S1\			

CLIENT

BioTherm Energy (Pty.) Ltd.

PROJECT NAME

Proposed Enamandla PV 5 Project near Aggeneys, Northern Cape

REPORT TYPE

Draft Environmental Scoping Report

WSP PROJECT NUMBER

47579

AUTHORITY REFERENCE NUMBERS

DEA: Not yet received

NEAS: Not yet received

PRODUCTION TEAM

CLIENT

Senior Associate	Michael Barnes
Environmental Manager	Irene Bezuidenhout
Analyst	Siphelele Dunga

WSP | PARSONS BRINCKERHOFF

Environmental Consultant	Bronwyn Fischer
Project Manager	Ashlea Strong
Project Director	Nigel Seed
Social Specialists	Danielle Sanderson and Hillary Konigkramer
Soil and Land Specialist	Capability Bruce Wickham

SUBCONSULTANTS

Heritage Specialist	ACO Associates – Tim Hart, Lita Webley and David Harkett
Avifauna Specialist	Chris van Rooyen
Visual Specialist	Belinda Genhardt
Paleontological Specialist	Natura Viva – John Almond
Biodiversity Specialist	Simon Todd
Traffic Specialist	WSP Group Africa – Christo Bredenhann

TABLE OF CONTENTS

1	INTRODUCTION.....	1
1.1	PURPOSE OF THIS REPORT	1
1.2	BACKGROUND INFORMATION	1
1.3	SCOPING TERMS OF REFERENCE	3
1.4	SCOPING REPORT STRUCTURE	4
1.5	ASSUMPTIONS AND LIMITATIONS	6
2	GOVERNANCE FRAMEWORK	8
2.1	INSTITUTIONAL FRAMEWORK	8
2.2	NATIONAL LEGAL AND REGULATORY FRAMEWORK.....	8
2.3	PROVINCIAL CONTEXT	14
2.4	MUNICIPAL CONTEXT	16
2.5	STRATEGIC ENERGY PLANNING CONTEXT.....	18
2.6	SOUTH AFRICAN STANDARDS AND GUIDELINES	1
2.7	INTERNATIONAL STANDARDS AND GUIDELINES.....	1
3	SCOPING METHODOLOGY	4
3.1	APPLICATION.....	4
3.2	BASELINE ENVIRONMENTAL ASSESSMENT	4
3.3	IDENTIFICATION AND EVALUATION OF POTENTIALLY SIGNIFICANT IMPACTS.....	4
3.4	STAKEHOLDER ENGAGEMENT.....	5
4	NEED AND JUSTIFICATION	9
4.1	NATIONAL RENEWABLE ENERGY REQUIREMENT	9
4.2	SOLAR POWER POTENTIAL IN SOUTH AFRICA AND INTERNATIONALLY	9
4.3	REGIONAL AND SITE SUITABILITY	10
4.4	LOCAL NEED.....	10

5	PROJECT DESCRIPTION.....	12
5.1	LOCATION OF THE PROPOSED PROJECT	12
5.2	SOLAR POWER GENERATION PROCESS.....	17
5.3	PROJECT INFRASTRUCTURE.....	23
5.4	PROPOSED PROJECT DEVELOPMENT ACTIVITIES.....	24
5.5	PROJECT ALTERNATIVES	26
6	DESCRIPTION OF THE BASELINE ENVIRONMENT	38
6.1	TOPOGRAPHY	38
6.2	GEOLOGY.....	38
6.3	CLIMATE	40
6.4	SOILS AND LAND CAPABILITY.....	43
6.5	NATURAL VEGETATION AND ANIMAL LIFE	50
6.6	AVIFAUNA	54
6.7	SURFACE WATER	62
6.8	GROUNDWATER.....	64
6.9	HERITAGE	65
6.10	PALAEONTOLOGY	67
6.11	VISUAL.....	68
6.12	SOCIAL ENVIRONMENT.....	70
7	IDENTIFICATION OF POTENTIAL IMPACTS	76
7.1	PHASES OF DEVELOPMENT.....	76
7.2	ACTIVITIES MATRIX	76
7.3	TOPOGRAPHY	80
7.4	GEOLOGY.....	80
7.5	CLIMATE	81
7.6	SOILS AND LAND CAPABILITY.....	82
7.7	NATURAL VEGETATION AND ANIMAL LIFE	83

7.8	AVIFAUNA	87
7.9	SURFACE WATER	89
7.10	GROUNDWATER.....	90
7.11	HERITAGE	91
7.12	PALAEONTOLOGY	93
7.13	VISUAL.....	94
7.14	TRAFFIC AND TRANSPORTATION.....	99
7.15	SOCIAL ENVIRONMENT.....	100
8	CONCLUSIONS AND RECOMMENDATIONS.....	106
9	PLAN OF STUDY FOR THE ENVIRONMENTAL IMPACT REPORTING PHASE	111
9.1	TERMS OF REFERENCE	111
9.2	ALTERNATIVES	111
9.3	ASPECTS TO BE ASSESSED IN THE EIA PROCESS	114
9.4	DESCRIPTION OF EIA TASKS	116
9.5	SPECIALIST STUDIES	116
9.6	IMPACT ASSESSMENT METHODOLOGY	121
9.7	ENVIRONMENTAL IMPACT REPORT	124
9.8	STAKEHOLDER AND AUTHORITY ENGAGEMENT.....	125
9.9	PROGRESSION OF AUTHORISATIONS, PERMITS AND OTHER DEVELOPMENT APPROVALS	126
10	WAY FORWARD	128
11	REFERENCES.....	129

TABLES

TABLE 1-1:	PROJECTS WITHIN THE SOLAR ENERGY DEVELOPMENT	1
------------	----------------------------------------------------	---

TABLE 1-2:	LEGISLATION REQUIREMENTS AS DETAILED IN GNR 982	4
TABLE 2-1:	DETERMINATION OF APPLICABLE GNR 983 LISTED ACTIVITIES.....	9
TABLE 2-2:	DETERMINATION OF APPLICABLE GNR 984 LISTED ACTIVITIES.....	10
TABLE 2-3:	DETERMINATION OF APPLICABLE GNR 985 LISTED ACTIVITIES.....	10
TABLE 3-1:	SIGNIFICANCE SCREENING TOOL	5
TABLE 3-2:	PROBABILITY SCORES AND DESCRIPTORS	5
TABLE 3-3:	CONSEQUENCE SCORES AND DESCRIPTORS.....	5
TABLE 3-4:	DATES ON WHICH THE ADVERTS WERE PUBLISHED.....	6
TABLE 3-5:	MEETINGS TO BE HELD DURING THE DRAFT SCOPING REPORT REVIEW PERIOD	7
TABLE 5-1:	EXISTING ENVIRONMENTAL AUTHORISATIONS WITHIN 65KM OF ENAMANDLA PV 5	14
TABLE 5-2:	DETAILS OF THE PROPOSED PV PLANT AND ASSOCIATED INFRASTRUCTURE	23
TABLE 5-3:	ADVANTAGES AND DISADVANTAGES OF SOLAR PV GENERATING TECHNOLOGY	32
TABLE 6-1:	SUMMARY OF SOIL SAMPLE CHARACTERISTICS.....	47
TABLE 6-2:	LISTED SPECIES KNOWN FROM THE BROAD AREA AROUND THE SITE	51
TABLE 6-3:	PRIORITY SPECIES THAT COULD POTENTIALLY OCCUR IN THE STUDY AREA (EN = ENDANGERED, VU = VULNERABLE, NT = NEAR THREATENED, LC = LEAST CONCERN)	58
TABLE 6-4:	IRRIGATION WATER USE WITHIN TERTIARY D82	63
TABLE 6-5:	WATER USERS WITHIN TERTIARY D82 (EXCLUDING IRRIGATION)	64
TABLE 6-6:	HYDRAULIC PARAMETERS FOR BOREHOLES	65
TABLE 6-7:	DESCRIPTION OF LOCAL COMMUNITIES	74
TABLE 7-1:	ACTIVITIES MATRIX (C – CONSTRUCTION, O – OPERATION, D – DECOMMISSIONING).....	77
TABLE 7-2:	IMPACT SIGNIFICANCE SCREENING FOR POTENTIAL TOPOGRAPHY IMPACTS.....	80
TABLE 7-3:	IMPACT SIGNIFICANCE SCREENING FOR POTENTIAL GEOLOGY IMPACTS	81
TABLE 7-4:	IMPACT SIGNIFICANCE SCREENING FOR POTENTIAL CLIMATE IMPACTS.....	81
TABLE 7-5:	IMPACT SIGNIFICANCE SCREENING FOR POTENTIAL SOIL AND LAND CAPABILITY IMPACTS	83
TABLE 7-6:	IMPACT SIGNIFICANCE SCREENING FOR POTENTIAL BIODIVERSITY IMPACTS.....	85
TABLE 7-7:	IMPACT SIGNIFICANCE SCREENING FOR POTENTIAL AVIFAUNA IMPACTS	88
TABLE 7-8:	IMPACT SIGNIFICANCE SCREENING FOR POTENTIAL SURFACE WATER IMPACTS.....	90
TABLE 7-9:	IMPACT SIGNIFICANCE SCREENING FOR POTENTIAL GROUND WATER IMPACTS.....	91
TABLE 7-10:	IMPACT SIGNIFICANCE SCREENING FOR POTENTIAL HERITAGE IMPACTS.....	93

TABLE 7-11:	IMPACT SIGNIFICANCE SCREENING FOR POTENTIAL PALAEOLOGICAL IMPACTS	94
TABLE 7-12:	IMPACT SIGNIFICANCE SCREENING FOR POTENTIAL VISUAL IMPACTS	98
TABLE 7-13:	IMPACT SIGNIFICANCE SCREENING FOR POTENTIAL TRAFFIC IMPACTS	99
TABLE 7-14:	IMPACT SIGNIFICANCE SCREENING FOR POTENTIAL SOCIAL IMPACTS	104
TABLE 8-1:	SUMMARY OF SCOPING PHASE IMPACT ASSESSMENT PROCESS.....	107
TABLE 9-1:	PLAN OF STUDY STRUCTURE	111
TABLE 9-2:	ALTERNATIVES SUMMARY.....	112
TABLE 9-3:	SUMMARY OF ASPECTS TO BE ADDRESSED IN THE EIA PHASE	114
TABLE 9-4:	DETAILS OF THE SPECIALIST CONSULTANTS	116
TABLE 9-5:	OTHER DEVELOPMENT APPROVALS, AUTHORISATIONS AND PERMITS REQUIRED FOR THE PROPOSED PROJECT	127

FIGURES

FIGURE 1-1:	THE PROPOSED SOLAR ENERGY DEVELOPMENT.....	2
FIGURE 2-1:	NORTHERN CAPE DEVELOPMENT REGIONS AND CORRIDORS	16
FIGURE 2-2:	THE PROPOSED PROJECT DEVELOPMENT SITE ADJACENT TO THE SPRINGBOK WIND REDZ	21
FIGURE 5-1:	THE LOCATION OF THE EXISTING ENVIRONMENTAL AUTHORISATIONS WITHIN 65KM OF ENAMANDLA PV 5	13
FIGURE 5-2:	THE ENAMANDLA PV 5 PROJECT FORMING PART OF THE GREATER ENAMANDLA PROJECT	16
FIGURE 5-3:	LARGE-SCALE PHOTOVOLTAIC POWER GENERATION FACILITY (SOURCE: WWW.PV-MAGAZINE.COM).....	18
FIGURE 5-4:	SIMPLIFIED PHOTOVOLTAIC POWER GENERATION FLOW DIAGRAM (SOURCE: WWW.HOLBERT.FACULTY.ASU.EDU)....	18
FIGURE 5-5:	PROCESS OF ENERGY CONVERSION IN A CSP PLANT	19
FIGURE 5-6:	PARABOLIC TROUGH (SOURCE: WSP PARSONS BRINCKERHOFF).....	20
FIGURE 5-7:	PARABOLIC TROUGH ABSORBER TUBE (SOURCE: WSP PARSONS BRINCKERHOFF).....	20
FIGURE 5-8:	FLOW DIAGRAM FOR A PARABOLIC TROUGH CSP FACILITY (SOURCE: WWW.SOLARCELLCENTRAL.COM)	21
FIGURE 5-9:	HELIOSTAT	21
FIGURE 5-10:	CENTRAL RECEIVER (SOURCE: WWW.TORRESOLARENERGY.COM)	22
FIGURE 5-11:	ELLIPTICAL FORMATION OF THE CENTRAL TOWER SOLAR FIELD (SOURCE: WWW.FINETUBES.CO.UK)	22

FIGURE 5-12:	FLOW DIAGRAM SHOWING THE POWER GENERATION PROCESS IN A CENTRAL TOWER CSP FACILITY (SOURCE: WWW.SOLARNOVUS.COM)	23
FIGURE 5-13:	SITE SELECTION PROCESS FLOW DIAGRAM.....	27
FIGURE 5-14:	LOCATION OF THE PROPOSED SITE IN RELATION TO THE SPRINGBOK WIND REDZ	29
FIGURE 5-15:	IDENTIFIED DEVELOPMENT AREA	29
FIGURE 5-16:	LOCATION OF THE PROPOSED ENAMANDLA PV 5 (ALTERNATIVE 1)	30
FIGURE 5-17:	NEW SOLAR ENERGY DEVELOPMENT LAYOUT	31
FIGURE 5-18:	LOCATION OF THE PROPOSED ENAMANDLA PV 5 (POST SCOPING ALTERNATIVE 2).....	32
FIGURE 5-19:	TWO ALTERNATIVE MAIN ACCESS ROUTES	34
FIGURE 5-20:	STEEL / CONCRETE MONOPOLE SINGLE CIRCUIT STRUCTURE	35
FIGURE 5-21:	STEEL / CONCRETE MONOPOLE DOUBLE CIRCUIT STRUCTURE	35
FIGURE 5-22:	H-POLE STRUCTURE (USUALLY WOODEN POLES).....	36
FIGURE 6-1:	ELEVATION PROFILE FOR THE PROPOSED SITE	38
FIGURE 6-2:	GEOLOGICAL MAP.....	39
FIGURE 6-3:	AVERAGE TEMPERATURES AND PRECIPITATION FOR AGGENEYS	40
FIGURE 6-4:	THE NUMBER OF SUNNY, PARTLY CLOUDY AND OVERCAST DAYS FOR AGGENEYS.....	41
FIGURE 6-5:	MAXIMUM TEMPERATURES FOR AGGENEYS	41
FIGURE 6-6:	PRECIPITATION DAYS FOR AGGENEYS.....	42
FIGURE 6-7:	AVERAGE WIND SPEEDS FOR AGGENEYS	42
FIGURE 6-8:	WIND ROSE FOR AGGENEYS	43
FIGURE 6-9:	RED APEDAL NAMIB SOIL FORM	44
FIGURE 6-10:	SOIL LAND TYPES FOR ENAMANDLA PV 5 (BLUE STAR).....	45
FIGURE 6-11:	SOIL SAMPLING LOCATIONS WITHIN FARM RE 86 (ENAMANDLA PV 5 INDICATED WITH BLUE STAR).....	46
FIGURE 6-12:	BLACK MOUNTAIN TAILINGS DAM.....	48
FIGURE 6-13:	NATIONAL LAND COVER FOR THE STUDY AREA (ENAMANDLA PV 5 INDICATED WITH A RED STAR).....	49
FIGURE 6-14:	BROAD-SCALE OVERVIEW OF THE VEGETATION IN AND AROUND ENAMANDLA PV 5 (BLUE STAR).....	50
FIGURE 6-15:	CRITICAL BIODIVERSITY AREAS MAP OF THE AREA AROUND ENAMANDLA PV 5 (BLUE STAR)	52
FIGURE 6-16:	MAP OF DEA REGISTERED RENEWABLE ENERGY APPLICATIONS AS OF APRIL 2016.....	53
FIGURE 6-17:	THE PROPOSED STUDY AREA (ORANGE) IN RELATION TO THE HARAMOEP AND BLACK MOUNTAIN (SA035) IMPORTANT BIRD AREA.....	56
FIGURE 6-18:	LOWER ORANGE WMA (LEFT) AND QUATERNARY CATCHMENTS (RIGHT).....	62
FIGURE 6-19:	MAP COMPILED BY THE BRITISH INTELLIGENCE DEPARTMENT (1900) OF BUSHMANLAND (SCALE 1:250 000). NOTE THE POSITION OF HARTEBEEST VLEI. THE LOCATION	

	OF AGGENEYS IN SHOWN IN BLUE, AND NAMIES IS SHOWN IN YELLOW.....	67
FIGURE 6-20:	VISUAL CHARACTER, CLEAR SKIES FLAT PLAINS AND KOPPIES	69
FIGURE 6-21:	REGIONAL LOCATION OF PROPOSED PROJECT.....	72
FIGURE 6-22:	LOCAL CONTEXT OF THE PROPOSED PROJECT (ENAMANDLA PV 5 INDICATED WITH A BLUE STAR)	75
FIGURE 7-1:	BIODIVERSITY SENSITIVE AREAS IN RELATION TO THE ENAMANDLA PV SITE 1 (BLUE STAR)	84
FIGURE 7-2:	HERITAGE SENSITIVE AREAS (SHOWN IN PINK) IN RELATION TO THE ENAMANDLA PV 5 (BLUE STAR)	92
FIGURE 7-3:	VISUAL SENSITIVE AREAS IN RELATION TO THE ENAMANDLA PV 5 (BLUE STAR)	96
FIGURE 8-1:	SENSITIVITY MAP FOR ENAMANDLA PV 5	110

APPENDICES

APPENDIX A	CURRICULUM VITAE
APPENDIX B	EAP DECLARATION OF INTEREST AND UNDERTAKING
APPENDIX C	SPECIALIST DECLARATIONS
APPENDIX D	DEA PRE-APPLICATION MEETING MINUTES
APPENDIX E	STAKEHOLDER DATABASE
APPENDIX F	ADVERTISEMENT
APPENDIX G	SOIL, LAND CAPABILITY AND WETLANDS SPECIALIST STUDY
APPENDIX H	BIODIVERSITY SPECIALIST STUDY
APPENDIX I	AVIFAUNA SPECIALIST STUDY
APPENDIX J	HERITAGE SPECIALIST STUDY
APPENDIX K	PALAEONTOLOGICAL SPECIALIST STUDY
APPENDIX L	VISUAL SPECIALIST STUDY
APPENDIX M	SOCIAL SPECIALIST STUDY
APPENDIX N	A3 MAPS

1 INTRODUCTION

1.1 PURPOSE OF THIS REPORT

This scoping report documents the process and findings of the scoping phase of the Scoping and Environmental Impact Reporting (S&EIR) process for the proposed establishment of the Enamandla Photovoltaic (PV) Site 5 project (hereafter referred to as 'Enamandla PV 5') which forms part of the establishment of a solar energy development on Farm Hartebeest Vlei 86, located approximately 13km southeast of Aggeneys located within the Khâi-Ma Local Municipality under the jurisdiction of the Namakwa District Municipality, South Africa.

The scoping report provides stakeholders and authorities with information that is necessary for a proper understanding of the scoping process; for informing all preferred alternatives, including location alternatives, the scope of the assessment, and the consultation process undertaken through the environmental impact assessment process.

1.2 BACKGROUND INFORMATION

BioTherm Energy (Pty.) Ltd. (BioTherm) is the proponent and applicant for the Environmental Authorisation (EA) for Enamandla PV 5. BioTherm is a leading renewable energy project development and financing company that owns, develops, constructs and operates solar and wind energy projects in South Africa and Sub-Saharan Africa.

BioTherm has proposed a solar energy development on Farm Hartebeest Vlei 86, located approximately 13km southeast of Aggeneys located within the Khâi-Ma Local Municipality under the jurisdiction of the Namakwa District Municipality, in the Northern Cape Province of South Africa. The solar energy development will consist of two 150MW Concentrating Solar Power (CSP) projects referred to as Letsoai CSP 1 and 2; and five 75MW Solar PV projects referred to as Enamandla PV 1 – 5 (**Figure 1-1**). The projects as well as associated infrastructure are summarised in **Table 1-1**.

Table 1-1: Projects within the Solar Energy Development

PROJECT NUMBER	TECHNOLOGY	LOCATION	PROJECTS
1	CSP	Northern Cape	<ul style="list-style-type: none"> → Letsoai CSP 1 (150MW) and associated infrastructure → Letsoai CSP 2 (150MW) and associated infrastructure
2	PV	Northern Cape	<ul style="list-style-type: none"> → Enamandla PV 1 (75MW) and associated infrastructure → Enamandla PV 2 (75MW) and associated infrastructure → Enamandla PV 3 (75MW) and associated infrastructure → Enamandla PV 4 (75MW) and associated infrastructure → Enamandla PV 5 (75MW) and associated infrastructure
3	Power Integration	Northern Cape	<ul style="list-style-type: none"> → 1 x 400kV Powerline and associated substation

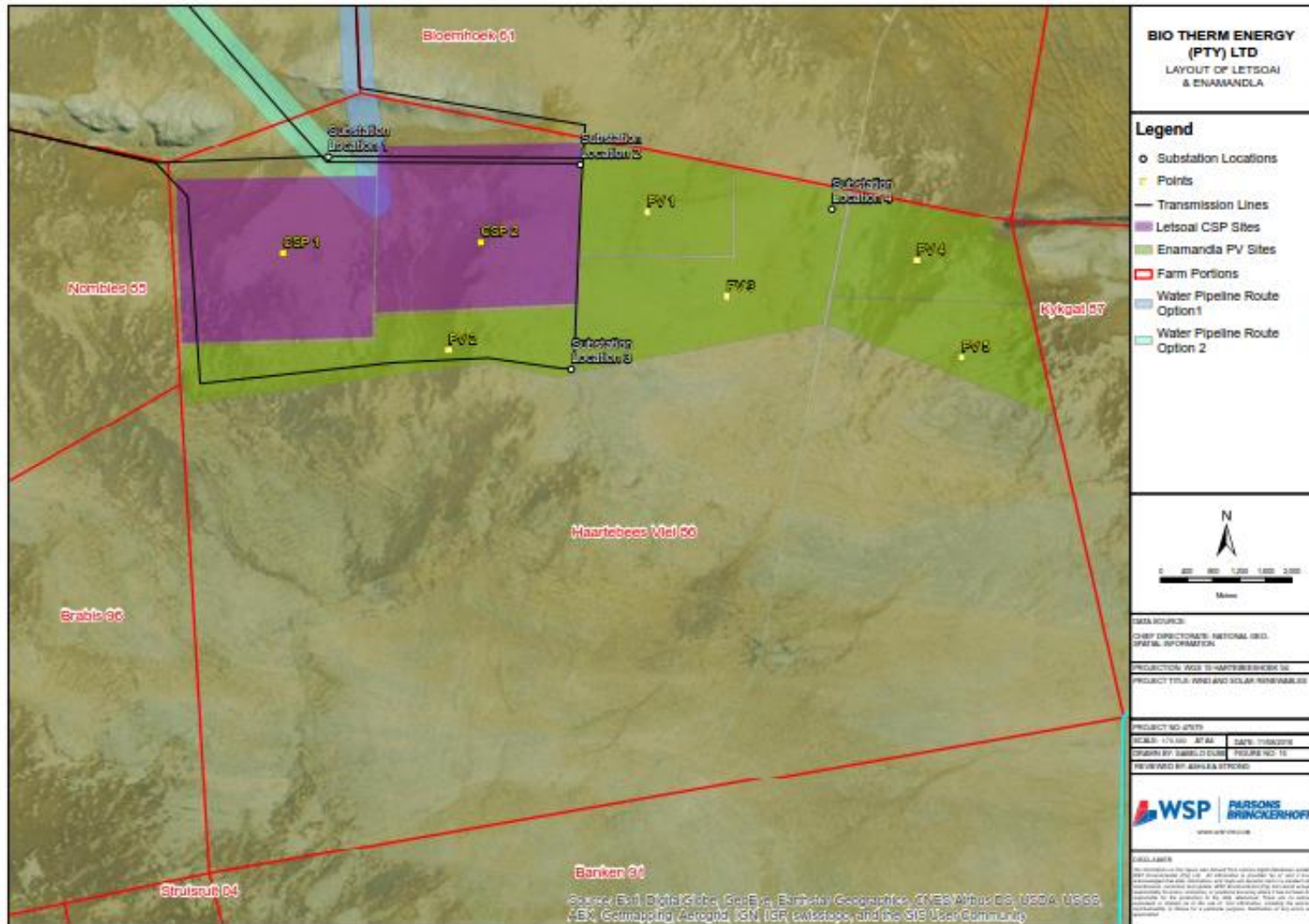

Figure 1-1: The Proposed Solar Energy Development

It is important to note that this S&EIR process is for Enamandla PV 5 only; the balance of the Enamandla PV and Letsoai CSP projects entail separate EA applications and S&EIR processes.

WSP| Parsons Brinckerhoff, Environment and Energy, Africa (WSP | Parsons Brinckerhoff) has been appointed in the role of Independent Environmental Assessment Practitioner (EAP) to undertake the S&EIR processes for each of the seven projects collectively forming part of the solar energy development. The CVs of the Project Director and Project Manager are available in **Appendix A**. The EAP declaration of interest and undertaking is included in **Appendix B**. In order to adequately identify and assess potential environmental impacts, the EAP was supported by a number of specialists. The signed Specialist Declarations are included in **Appendix C**.

1.3 SCOPING TERMS OF REFERENCE

The EIA Regulations (GNR 982 of 2014) identify Enamandla PV 5 as an activity being subject to a S&EIR process due to the applicability of the EIA Listing Notices Government Regulation Notice (GNR) 983 and 984 (8 December 2014). In order for the project to proceed it will require an EA from the Department of Environmental Affairs (DEA).

WSP| Parsons Brinckerhoff has been appointed as the independent EAP to carry out the S&EIR process in accordance with the EIA Regulations, 2014.

As defined in Appendix 2 of GNR 982 of 2014, the objective of the scoping process is to, through a consultative process:

- Identify the relevant policies and legislation relevant to the activity;
- Motivate the need and desirability of the proposed activity, including the need and desirability of the activity in the context of the preferred location;
- Identify and confirm the preferred activity and technology alternative through an impact and risk assessment and ranking process;
- Identify and confirm the preferred site, through a detailed site selection process, which includes an impact and risk assessment process inclusive of cumulative impacts and a ranking process of all the identified alternatives focusing on the geographical, physical, biological, social, economic, and cultural aspects of the environment;
- Identify the key issues to be addressed in the assessment phase;
- Agree on the level of assessment to be undertaken, including the methodology to be applied, the expertise required as well as the extent of further consultation to be undertaken to determine the impacts and risks the activity will impose on the preferred site through the life of the activity, including the nature, significance, consequence, extent, duration and probability of the impacts to inform the location of the development footprint within the preferred site; and
- Identify suitable measures to avoid, manage or mitigate identified impacts and to determine the extent of the residual risks that need to be managed and monitored.

Public participation is a requirement of scoping; it consists of a series of inclusive and culturally appropriate interactions aimed at providing stakeholders with opportunities to express their views, so that these can be considered and incorporated into the S&EIR decision-making process. Effective public participation requires the prior disclosure of relevant and adequate project information to enable stakeholders to understand the risks, impacts, and opportunities of the Proposed Project. The objectives of the public participation process can be summarised as follows:

- Identify relevant individuals, organisations and communities who may be interested in or affected by the Proposed Project;

- Clearly outline the scope of the Proposed Project, including the scale and nature of the existing and proposed activities;
- Identify viable Proposed Project alternatives that will assist the relevant authorities in making an informed decision;
- Identify shortcomings and gaps in existing information;
- Identify key concerns, raised by Stakeholders that should be addressed in the subsequent specialist studies;
- Highlight the potential for environmental impacts, whether positive or negative; and
- To inform and provide the public with information and an understanding of the Proposed Project, issues and solutions.

1.4 SCOPING REPORT STRUCTURE

Table 1-2 cross-references the sections within the scoping report with the legislated requirements as per Appendix 2 of GNR 982 of 2014.

Table 1-2: Legislation Requirements as detailed in GNR 982

APPENDIX 2	LEGISLATED REQUIREMENTS AS PER THE NEMA GNR 982	RELEVANT REPORT SECTION
(a)	Details of	
	i) the EAP who compiled the report; and	Section 1.2 and Appendix A
	ii) the expertise of the EAP, including a Curriculum Vitae	Appendix A
(b)	The location of the activity, including-	
	i) The 21 digit Surveyor code for each cadastral land parcel;	Section 5.1
	ii) Where available, the physical address and farm name	Section 5.1
	iii) Where the required information in terms of (i) and (ii) is not available, the coordinates of the boundary of the property.	Section 5.1 and Figure 5.2
(c)	A plan which locates the proposed activities applied for at an appropriate scale, or, if it is-	
	i) A linear activity, a description of the corridor in which the proposed activity or activities is to be undertaken; or	N/A
	ii) On land where the property has not been defined, the coordinates within which the activity is to be undertaken.	Section 5.1 and Figure 5.2
(d)	A description of the proposed activity, including-	
	i). All listed and specified activities triggered;	Section 2.2 Table 2.1 and Table 2.2
	ii). A description of the activities to be undertaken, including associated structures and infrastructure;	Chapter 5
(e)	A description of the policy and legislative context within which the development is proposed including an identification of all legislation, policies, plans, guidelines, spatial tools, municipal development planning frameworks and instruments that are applicable to this activity and are to be considered in the assessment process;	Chapter 2

APPENDIX 2	LEGISLATED REQUIREMENTS AS PER THE NEMA GNR 982	RELEVANT REPORT SECTION
(f)	A motivation for the need and desirability for the proposed development including the need and desirability of the activity in the context of the preferred location;	Chapter 4
(h)	A full description of the process followed to reach the proposed preferred activity, site and location within the site, including-	
	i). Details of all the alternatives considered;	Section 5.5
	ii). Details of the public participation undertaken in terms of regulation 41 of the Regulations, including copies of the supporting documents and inputs;	Chapter 3.4
	iii). a summary of the issues raised by interested and affected parties, and an indication of the manner in which the issues were incorporated, or the reasons for not including them;	Not yet applicable – to be included in the FSR
	iv). the environmental attributes associated with the alternatives focusing on the geographical, physical, biological, social, economic, heritage and cultural aspects;	Chapter 6
	v). the impacts and risks identified for each alternative, including the nature, significance, consequence, extent, duration and probability of the impacts, including the degree to which these impacts- (aa) can be reversed; (bb) may cause irreplaceable loss of resources; and (cc) can be avoided, managed or mitigated;	Chapter 7
	vi). the methodology used in determining and ranking the nature, significance, consequences, extent, duration and probability of potential environmental impacts and risks associated with the alternatives;	Section 3.3
	vii). positive and negative impacts that the proposed activity and alternatives will have on the environment and on the community that may be affected focusing on the geographical, physical, biological, social, economic, heritage and cultural aspects;	Chapter 7 and Chapter 8
	viii). the possible mitigation measures that could be applied and level of residual risk;	Chapter 7
	ix). the outcome of the site selection matrix;	Chapter 8
	x). if no alternatives, including alternative locations for the activity were investigated, the motivation for not considering such and	Section 5.5
xi). a concluding statement indicating the preferred alternatives, including preferred location of the activity;	Chapter 8	
(i)	A plan of study for undertaking the environmental impact assessment process to be undertaken, including-	
	i). a description of the alternatives to be considered and assessed within the preferred site, including the option of not proceeding with the activity;	Section 9.4

APPENDIX 2	LEGISLATED REQUIREMENTS AS PER THE NEMA GNR 982	RELEVANT REPORT SECTION
	ii). a description of the aspects to be assessed as part of the environmental impact assessment process;	Section 9.7
	iii). aspects to be assessed by specialists;	Section 9.7
	iv). a description of the proposed method of assessing the environmental aspects, including a description of the proposed method of assessing the environmental aspects including aspects to be assessed by specialists;	Section 9.7
	v). a description of the proposed method of assessing duration and significance;	Section 9.7
	vi). an indication of the stages at which the competent authority will be consulted;	Section 9.7
	vii). particulars of the public participation process that be conducted during the environmental impact assessment process; and	Section 9.7
	viii). a description of the tasks that will be undertaken as part of the environmental impact assessment process;	Section 9.7
	ix). identify suitable measures to avoid, reverse, mitigate or manage identified impacts and to determine the extent of the residual risks that need to be managed and monitored.	Section 9.7
(j)	An undertaking under oath or affirmation by the EAP in relation to-	
	i). the correctness of the information provided in the report;	Appendix B
	ii). the inclusion of comments and inputs from stakeholders and interested and affected parties; and	Appendix B
	iii). any information provided by the EAP to interested and affected parties and any responses by the EAP to comments or inputs made by interested or affected parties;	Appendix B
(k)	An undertaking under oath or affirmation by the EAP in relation to the level of agreement between the EAP and interested and affected parties on the plan of study for undertaking the environmental impact assessment;	Appendix B
(l)	Where applicable, any specific information required by the competent authority; and	N/A
(m)	Any other matter required in terms of section 24(4)(a) and (b) of the Act.	N/A

1.5 ASSUMPTIONS AND LIMITATIONS

General assumptions and limitations relating to the scoping study and the scoping report are listed below:

- The EAP hereby confirms that they have undertaken to obtain project information from the client that is deemed to be accurate and representative of the project;
- Site visits have been undertaken to better understand the project and ensure that the information provided by the client is correct, based on site conditions observed;

- The EAP hereby confirms their independence and understands the responsibility they hold in ensuring all comments received are accurately replicated and responded to within the EIA documentation; and
- The comments received in response to the public participation process, are representative of comments from the broader community; and
- The competent authority would not require additional specialist input, as per the proposals made in this report, in order to make a decision regarding the application.

Notwithstanding these assumptions, it is the view of WSP | Parsons Brinckerhoff that this draft scoping report (DSR) provides a good description of the issues associated with the project, and a reasonable plan of study for the environmental impact assessment (EIA) phase.

2 GOVERNANCE FRAMEWORK

The South African regulatory framework establishes well-defined requirements and standards for environmental and social management of industrial and civil infrastructure developments. Environmental protection functions are carried out by different authorities at both national and regional levels. The following sections outline summaries of:

- Key regulatory authorities and other relevant bodies related to the governance of the proposed activities, the S&EIR process, and other permitting requirements.
- Current national, provincial and local legislative framework in South Africa as it relates to the project during planning, development and operation; including national policies and standards referred to as guidelines for the identification and management (including mitigation) of impacts.

2.1 INSTITUTIONAL FRAMEWORK

The key institutions and their main roles and responsibilities in relation to the S&EIR process are described in the following subsections:

DECISION MAKING AUTHORITY

Due to the fact that this is a renewable energy project it is linked to the Integrated Resource Plan 2010. Section 24C(2)(a) of the National Environmental Management Act (No. 107 of 1998) (NEMA) stipulates that the Minister must be identified as the competent authority if the activity has implications for international environmental commitments or relations. At the 15th Conference of the Parties to the United Nations Framework Convention on Climate change held in 2010, the President, Mr Jacob Zuma, committed the country to voluntary reductions in CO₂ emissions through the Copenhagen Accord. As such, applications which fall within the energy reduction plans of government must be considered by the Minister. Therefore the DEA is the authorising department.

COMMENTING AUTHORITIES

The following will act as commenting authorities for this application:

- Northern Cape Department of Environment and Nature Conservation (NCDENC);
- Department of Water and Sanitation (DWS). The Department of Water and Sanitation Northern Cape Region will act as a commenting authority for this application and will provide input with regards to water use license requirements. The project falls within the Lower Orange Water Management Area;
- Khâi-Ma Local Municipality; and
- Namakwa District Municipality.

2.2 NATIONAL LEGAL AND REGULATORY FRAMEWORK

THE CONSTITUTION OF SOUTH AFRICA (NO. 108 OF 1996)

Since 1994 South African legislation, including environmental legislation has undergone a large transformation and various laws and policies were promulgated with a strong emphasis on environmental concerns and the need for sustainable development. The Constitution of South Africa (No. 108 of 1996) (The Constitution) provides environmental rights (contained in the Bill of Rights, Chapter 2, Section 24) and includes implications for environmental management. The environmental rights are guaranteed in Section 24 of the Constitution, and state that:

“Everyone has the right –

- *To an environment that is not harmful to their health or well-being and*
- *To have the environment protected, for the benefit of present and future generations, through reasonable legislative and other measures that:*
 - *Prevent pollution and ecological degradation;*
 - *Promote conservation and*
 - *Secure ecologically sustainable development and use of natural resources while promoting justifiable economic and social development.”*

The Constitution cannot manage environmental resources as a stand-alone piece of legislation hence additional legislation has been promulgated in order to manage the various spheres of both the social and natural environment. Each promulgated Act and associated Regulations are designed to focus on various industries or components of the environment to ensure that the objectives of the Constitution are effectively implemented and upheld on an on-going basis throughout the country. In terms of Section 7, a positive obligation is placed on the State to give effect to the environmental rights.

NATIONAL ENVIRONMENTAL MANAGEMENT ACT (NO. 107 OF 1998)

The NEMA provides the environmental legislative framework for South Africa and requires that activities be investigated that may have a potential impact on the environment, socio-economic conditions, and cultural heritage. The results of such investigation must be reported to the relevant authority. Procedures for the investigation and communication of the potential impact of activities are contained in Section 24(7) of the Act.

EIA REGULATIONS 2014

On the 4th December 2014 the Minister responsible for Environmental Affairs promulgated new EIA Regulations (GNR 982) in terms of Chapter 5 of the NEMA. The EIA Regulations contain three listing notices (GNR 983, 984 and 985) which identify activities that are subject to either a Basic Assessment or Scoping and EIA in order to obtain an EA. A Basic Assessment must be completed if the proposed project triggers activities listed in GNR 983 (Listing Notice 1) or GNR 985 (Listing Notice 3).

Table 2-1, Table 2-2 and **Table 2-3** outline the listed activities that are triggered by the proposed project under GNR 983, 984 and 985 respectively.

Table 2-1: Determination of Applicable GNR 983 Listed Activities

LISTED ACTIVITY AS DESCRIBED IN GNR 983	APPLICABLE (Y/N)	APPLICABILITY & LICENCE REQUIREMENT
(11)- The development of facilities or infrastructure for the transmission and distribution of electricity- (i) Outside urban areas or industrial complexes with a capacity of more than 33 but less than 275 kilovolts.	Applicable	Enamandla PV 5 will require the construction of an on-site substation and a 132kV overhead powerline. The powerline will all be outside an urban area and will connect to common on-site substation prior to the electricity being evacuated to the Eskom Grid.
(14)- The development of facilities or infrastructure, for the storage, or for the storage and handling, of a dangerous good, where such storage occurs in containers with a combined capacity of 80 cubic metres or more but not exceeding 500 cubic metres.	Applicable	Hazardous substances such as fuel will be required to be stored on site. The storage containers will have a combined capacity of more than 80m ³ but less than 500m ³ .

LISTED ACTIVITY AS DESCRIBED IN GNR 983	APPLICABLE (Y/N)	APPLICABILITY & LICENCE REQUIREMENT
(24)- The development of- (ii) A road with a reserve wider than 13,5 meters, or where no reserve exists where the road is no wider than 8 meters.	Potentially Applicable	Internal access roads will be required for access to Enamandla PV 5.
(28)- Residential, mixed, retail, commercial, industrial or institutional developments where such land was used for agriculture or afforestation on or after 01 April 1998 and where such development: (ii) Will occur outside an urban area, where the total land to be developed is bigger than 1 hectare.	Applicable	Enamandla PV 5 is proposed to be developed outside an urban area, on land that is utilised for agriculture, with a development footprint of more than 1 ha.
(56)- The widening of a road by more than 6 metres, or the lengthening of a road by more than 1 kilometre- (i) Where the existing reserve is wider than 13,5 meters; or	Potentially Applicable	The main access road that connects Enamandla PV 5 to the N14 may require widening and/or lengthening.

Table 2-2: Determination of Applicable GNR 984 Listed Activities

LISTED ACTIVITY AS DESCRIBED IN GNR 984	APPLICABLE (Y/N)	APPLICABILITY & LICENCE REQUIREMENT
(1)- The development of facilities or infrastructure for the generation of electricity from a renewable resource where the electricity output is 20 megawatts or more, excluding where such development of facilities or infrastructure is for photovoltaic installations and occurs within an urban area.	Applicable	Enamandla PV 5 will generate electricity from a renewable resource with an electricity output of more than 20 megawatts (75MW).
(15)- The clearance of an area of 20 hectares or more of indigenous vegetation, excluding where such clearance of indigenous vegetation is required for- (i) the undertaking of a linear activity; or (ii) maintenance purposes undertaken in accordance with a maintenance management plan.	Applicable	Enamandla PV 5 will require more than 20ha of indigenous vegetation to be cleared.

Table 2-3: Determination of Applicable GNR 985 Listed Activities

LISTED ACTIVITY AS DESCRIBED IN GNR 985	APPLICABLE	APPLICABILITY & LICENCE REQUIREMENT
(4) - The development of a road wider than 4 metres with a reserve less than 13,5 metres. In The Northern Cape -	Potentially Applicable	The presence of Critical Biodiversity Areas in the vicinity of the Enamandla PV 1 site will be confirmed during the EIA phase.

LISTED ACTIVITY AS DESCRIBED IN GNR 985	APPLICABLE	APPLICABILITY & LICENCE REQUIREMENT
(ee) Critical biodiversity areas as identified in systematic biodiversity plans adopted by the competent authority or in bioregional plans		
(12) - The clearance of an area of 300 square meters or more of indigenous vegetation except where such clearance of indigenous vegetation is required for maintenance purposes undertaken in accordance with a maintenance management plan In the Northern - (i) Within critical biodiversity areas identified in bioregional plans	Potentially Applicable	The presence of Critical Biodiversity Areas in the vicinity of the Enamandla PV 1 site will be confirmed during the EIA phase.
(14) - The development of – (xii) infrastructure or structures with a physical footprint of 10 square meters or more In the Northern Cape (ff) Critical biodiversity areas or ecosystem service areas as identified in systematic biodiversity plans adopted by the competent authority or in bioregional plans;	Potentially Applicable	The presence of Critical Biodiversity Areas in the vicinity of the Enamandla PV 1 site will be confirmed during the EIA phase.

Based on the determination above, activities listed in GNR 983, GNR 984 and GNR 985 are applicable to the project. The EIA Regulations stipulate that where both Listing Notices are applicable, the more rigorous process is to be followed - this case a S&EIR process will be undertaken in order to obtain the required necessary EA.

NATIONAL ENVIRONMENTAL MANAGEMENT WASTE ACT (NO. 59 OF 2008)

The National Environmental Management: Waste Act, 2008 (No. 59 of 2008) (NEM:WA) is subsidiary and supporting legislation to the NEMA. The Act is a framework legislation that provides the basis for the regulation of waste management. The Act also contains policy elements and gives a mandate for further regulations to be promulgated.

On 29 November 2013 GNR 921 was promulgated (repealing GNR 718) which contains a list of waste management activities that if triggered require a Waste Management License (WML) and in turn a Basic Assessment (Category A activities) or Scoping and EIA (Category B activities) process to be undertaken in terms of the NEMA EIA Regulations. Category C activities are required to comply with the Norms and Standards for Storage of Waste 2013 (GN. 926) and do not require authorisation.

It is anticipated that activities on the site will not require a WML, nor will Enamandla PV 5 be required to comply with the Norms and Standards for Storage of Waste. However, waste handling, storage and disposal during the construction and operational phase of the project must be undertaken in accordance with the requirements of this Act and the Best Practicable Environmental Option which will be incorporated into the site specific Environmental Management Programme (EMPr).

NATIONAL ENVIRONMENTAL MANAGEMENT AIR QUALITY ACT (NO. 39 OF 2004)

The NEM:AQA came into effect on 11 September 2005. A staggered promulgation that iteratively replaced sections of the Atmospheric Pollution Prevention Act, Act 45 of 1965 (APPA) saw the former Act fully repealed by 01 April 2010. The NEM:AQA aims to protect the environment by providing reasonable measures for the protection and enhancement of the quality of air in South Africa, to prevent air pollution and ecological degradation and to secure ecological sustainable development while promoting justifiable economic and social development.

In line with Section 21 of NEM:AQA, GNR 893 of 2013 provides the listed activities for which an AEL is required and the associated minimum emission standards (MES) by emission category.

In terms of Section 32 of the NEM:AQA The National Dust Control Regulations (GNR 827) were promulgated, which aim at prescribing general measures for the control of dust in both residential and non-residential areas.

Although no AEL will be required for the construction and operation of Enamandla PV 5, the dust control regulations will be applicable during construction.

NATIONAL WATER ACT (NO. 36 OF 1998)

The National Water Act, 1998 (No. 36 of 1998) provides the framework to protect water resources against over-exploitation and to ensure that there is water for social and economic development, human needs and to meet the needs of the aquatic environment.

The Act defines water source to include watercourses, surface water, estuary or aquifer. A watercourse is defined in the Act as a river or spring, a natural channel in which water flows regularly or intermittently, a wetland, lake or dam into which or from which water flows, and any collection of water which the Minister may declare a watercourse.

Section 21 of the Act outlines water a number of categories which require a the water user to apply for a Water Use License (WUL) and Section 22 requires water users to apply for a General Authorisation (GA) with the Department of Water and Sanitation (DWS) if they are under certain thresholds or meet certain criteria. The list of water uses that require a WUL under section 21:

- (a) Taking water from a water resource;
- (b) Storage of water;
- (c) impeding or diverting the flow of water in a watercourse;
- (d) engaging in a stream flow reduction activity;
- (e) engaging in a controlled activity;
- (f) Discharging waste or water containing waste into a water resource through a pipe, canal, sewer, sea outfall or other conduit;
- (g) Disposing of waste in a manner which may detrimentally impact on a water resource;
- (h) Disposing in any manner of water which contains waste from, or which has been heated in, any industrial or power generation process;
- (i) Altering the bed, banks, course or characteristics of a watercourse;
- (j) Removing, discharging or disposing of water found underground if it is necessary for the efficient continuation of an activity or for the safety of people; and
- (k) Using water for recreational purposes.

The preliminary review of the baseline environment shows that ground water resources are limited and discussions are being undertaken with Sedibeng Water as well as other potential water supply partners in order to obtain water without having to abstract from the Orange River. Therefore, it is currently not anticipated that a WUL will be needed for the abstraction of water under Section 21(a).

Due to the fact that there are no surface water resources on the site, it is not anticipated that a WUL will be needed for the crossing of a watercourse in terms of Section 21(c) and (i) viz. impeding or diverting the flow of water in a watercourse and the altering of bed, banks, course or characteristics of a watercourse.

NATIONAL ENVIRONMENTAL MANAGEMENT BIODIVERSITY ACT (NO. 10 OF 2004)

The National Environmental Management: Biodiversity Framework Act, 2004 (No. 10 of 2004) (NEMBA) was promulgated in June 2004 within the framework of NEMA to provide for the management and conservation of national biodiversity. The NEMBA's primary aims are for the protection of species and ecosystems that warrant national protection, the sustainable use of indigenous biological resources, the fair and equitable sharing of benefits arising from bioprospecting involving indigenous biological resources. In addition, the NEMBA provides for the establishment and functions of a South African National Biodiversity Institute (SANBI).

SANBI was established by the NEMBA with the primary purpose to report on the status of the country's biodiversity and conservation status of all listed threatened or protected species and ecosystems.

The construction of the project, including the associated infrastructure may negatively impact on the biodiversity of the area, even though Enamandla PV 5 is located just outside one of the Renewable Energy Development Zones (REDZ). As such, SANBI will be invited to provide comment on the proposed project and any licenses or permits that maybe applicable will be obtained.

NATIONAL HERITAGE RESOURCES ACT (NO. 25 OF 1999)

The National Heritage Resource Act (No. 25 of 1999) (NHRA) serves to protect national and provincial heritage resources across South Africa. The NHRA provides for the protection of all archaeological and palaeontological sites, the conservation and care of cemeteries and graves by South African Heritage Resources Agency (SAHRA), and lists activities which require any person who intends to undertake to notify the responsible heritage resources agency and furnish details regarding the location, nature, and extent of the proposed development.

In terms of the Section 38 of NHRA, any person who intends to undertake a linear development exceeding 300m in length or a development that exceeds 5000m² must notify the heritage resources authority and undertake the necessary assessment requested by that authority.

In the case of Enamandla PV 5, a Heritage Impact Assessment (HIA) will be undertaken looking at Archaeology, Heritage and Palaeontology. The proposed project will be brought to the attention of SAHRA who will provide comment, and provide the required approval.

CIVIL AVIATION ACT (NO. 13 OF 2009)

Civil aviation in South Africa is governed by the Civil Aviation Act, 2009 (No. 13 of 2009). This Act provides for the establishment of a stand-alone authority mandated with controlling, promoting, regulating, supporting, developing, enforcing and continuously improving levels of safety and security throughout the civil aviation industry. This mandate is fulfilled by the South African Civil Aviation Authority (SA CAA) as an agency of the Department of Transport (DoT). The SA CAA achieves the objectives set out in the Act by complying with the Standards and Recommended Practices (SARPs) of the International Civil Aviation Organisation (ICAO), while considering the local context when issuing the South African Civil Aviation Regulations (SA CARs). All proposed developments or activities in South Africa that potentially could affect civil aviation must thus be assessed by SACAA in terms of the SA CARs and South African Civil Aviation Technical Standards (SA CATS) in order to ensure aviation safety.

The Obstacle Evaluation Committee (OEC) which consists of members from both the SA CAA and South African Air Force (SAAF) fulfils the role of streamlining and coordinating the assessment and approvals of proposed developments or activities that have the potential to affect civil aviation, military aviation, or military areas of interest. With both being national and international priorities,

the OEC is responsible for facilitating the coexistence of aviation and renewable energy development, without compromising aviation safety.

The details of the project will be provided to the SA CAA, which will be required to provide comment and approval of the proposed location and development of Enamandla PV 5.

ASTRONOMY GEOGRAPHIC ACT (ACT NO. 21 OF 2007)

The Astronomy Geographic Act, 2007 (No. 21 of 2007) provides for:

- The preservation and protection of areas that are uniquely suited for optical and radio astronomy;
- Intergovernmental cooperation and public consultation on matters concerning nationally significant astronomy advantage areas and matters connected herewith.

In terms of section 7(1) and 7(2) of this Act, national government established core astronomy advantage areas. As such, all land within a 3 km radius of the centre of the Southern African Large Telescope (SALT) dome located in the Northern Cape Province falls under the Sutherland Core Astronomy Advantage Area. The declaration also applies to core astronomy advantage area containing the MeerKAT radio telescope and the core of the planned Square Kilometer Array (SKA) telescope.

Under section 22(1) of the Act the national government has the authority to protect the radio frequency spectrum for astronomy observations within a core or central astronomy advantage area. As such no person may undertake certain activities within a core or central astronomy advantage area. These activities prohibited include the construction, expansion or operation; of any fixed radio frequency interference source, facilities for the generation, transmission or distribution of electricity, or any activity capable of causing radio frequency interference or which may detrimentally influence the astronomy and scientific endeavours.

Although none of the proposed projects are within the Core SKA area, any renewable energy project being proposed within the Northern Cape should receive comment from SKA, regardless of the proposed technology.

NATIONAL OCCUPATIONAL HEALTH AND SAFETY ACT

The National Occupational Health and Safety Act (No. 85 of 1993) and the relevant regulations under the Act are applicable to the proposed project. This includes the Construction Regulations promulgated in 2014 under Section 43 of the Act. Adherence to South Africa's Occupational Health and Safety (OHS) Act and its relevant Regulations, is essential. It is noted that adherence to the South African OHS Act will also ensure adherence to the relevant occupational health and safety provisions contained within the International Finance Corporation (IFC) general Environmental, Health and Safety (EHS) Guidelines 2007, given that the South African standards either meet or exceed the relevant IFC guidelines.

2.3 PROVINCIAL CONTEXT

NORTHERN CAPE PROVINCE SPATIAL DEVELOPMENT FRAMEWORK

The Northern Cape Spatial Development Framework (PSDF) is a policy document that promotes a 'developmental state' in accordance with national and provincial legislation and directives. It aligns with the Northern Cape Provincial Growth and Development Strategy which has committed the Northern Cape to 'building a prosperous, sustainable and growing provincial economy which reduces poverty and improves social development'

The PSDF is premised upon and gives effect to the following five strategic objectives of the National Development Strategy for Sustainable Development (NSSD 2011-2014):

- Enhancing systems for integrated planning and implementation
- Sustaining our ecosystem and using natural efficiently
- Towards green economy
- Building sustainable communities
- Responding effectively to climate change

The PSDF makes reference to the need to ensure the availability of energy and the potential for renewable energy generation within the province. Under Section B14, Economic Development Profile, The White Paper on Renewable Energy (2003) discussed a 10 000GWh of energy to be produced from renewable energy sources. The PSDF identifies that the total area of high radiation in South Africa amounts to approximately 194 000km², of which the majority falls within the Northern Cape. It is estimated that, if the electricity production per km² of mirror surface in solar thermal power stations were 30.2MW and only 1% of the area of high radiation were available for solar generation, generation potential would equate to approximately 64GW. A mere 1.25% of the area of high radiation could thus meet projected South African electricity demand in 2025 (80GW).

In addition the PSDF identifies that the implementation of large CSP plants has been proposed as one of the main contributors to greenhouse gas emission reductions in South Africa. Various solar parks and CSP plants have been proposed within the province.

Under Section B15 the PSDF unpacks the establishment of development regions and corridors of the Northern Cape as a response to the availability of environmental capital and infrastructure capital, which over time has resulted in the creation of distinct development regions and corridors. **Figure 2-1**, shows the development regions and corridors of the Northern Cape. The Solar Corridor centres around Upington and extends from roughly Kakamas in the north to De Aar in the east.

One of the policies outlined with the PSDF is for renewable energy sources to comprise 25% of the province's energy capacity by 2020. The proposed project therefore aids the province in reaching its 2020 target, even though it is not located within the Northern Cape Solar Corridor.

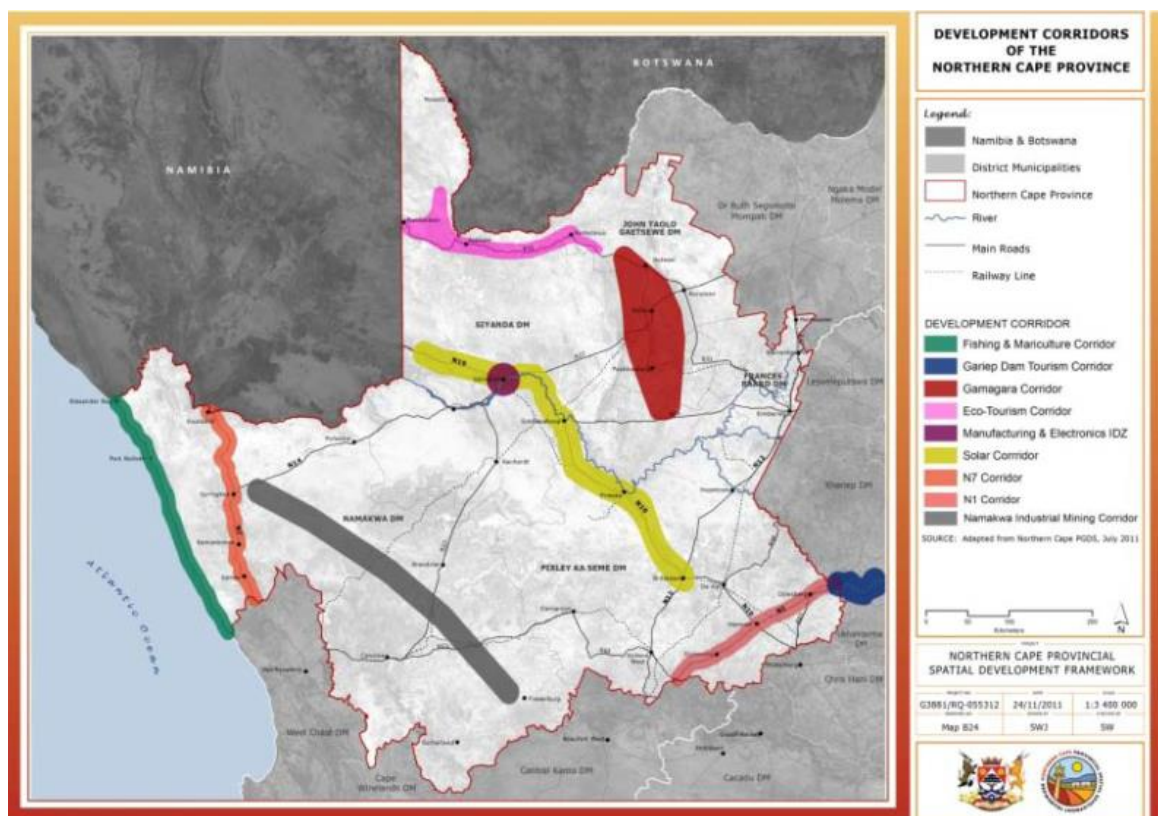

Figure 2-1: Northern Cape Development Regions and Corridors

2.4

MUNICIPAL CONTEXT

NAMAKWA DISTRICT MUNICIPALITY INTEGRATED DEVELOPMENT PLAN

The Namakwa District Municipality Integrated Development Plan (IDP) has been developed to align with the National Development Plan, which has identified various central development challenges. The challenges in the NDP have a direct impact on the development and growth in the Namakwa District. The Key Challenges identified within the NDP are:

- Unemployment;
- Poor quality of education;
- Ineffective economic infrastructure, poorly located, under-maintained and insufficient to support sustainable growth;
- Spatial Development patterns exclude the poor from benefitting from the fruits of development;
- The economy needs transformation in terms of resource management and use;
- Ineffective public health system;
- Public services are uneven and often of poor quality;
- Corrupt activities; and
- Transform in coherent South African society.

To create a better life for the people of Namakwa the focus and alignment of priorities as identified in the National Development Plan – Vision 2030 are:

- Creating jobs and livelihoods;
- Expanding infrastructure;
- Transitioning to a low-carbon economy;
- Transforming our spatial reality;
- Improving education and training;
- Providing quality healthcare;
- Building a capable state;
- Fighting corruption and enhancing accountability; and
- Transforming society and uniting the nation.

The IDP identifies issues that need to be focused on if the NDM want to maximise service delivery potential. A number of programs of action have been drafted with specific focus areas. One of the programmes of action is economic development, for the promotion of the standard of living and economic health and wealth of the communities in a sustainable qualitative manner by optimal utilization of natural and human resources. One of the focus areas is the optimal utilization of Natural Resources in a sectoral manner, which includes renewable energy.

KHÂI-MA LOCAL MUNICIPALITY INTEGRATED DEVELOPMENT PLAN

The Khai -Ma Municipality's mission is to ensure affordable service delivery and sustainable economic development through good and transparent municipal governance. The strategic objectives of the IDP include the following:

- Provision of sustainable services to the inhabitants and maintain existing resources.
- Develop Khâi- ma Municipality as institution through transformation and capacity building.
- Promotion of local economic development through poverty alleviation, job creation, empowerment of the previous disadvantage people with capacity building in business skills and establishment of a climate for investment.
- Promote Sound financial management and viability.

The Khai- Ma Municipality has set out spatial objectives and goals to optimally develop the “inherent economic opportunities, i.e. mining, agriculture, tourism, to protect and utilize the rich and diverse natural and cultural heritage for the enjoyment of all, and to develop sustainable settlements where residents can live enriched, healthy and convenient lives” (Khâi-Ma Municipality IDP 2012-2017).

The IDP lists a number of spatial objectives and describes associated strategies to meet the objectives. One of the spatial objectives detailed in the IDP is to create sustainable urban and rural settlements. The following five spatial strategies have created:

- Strengthen hierarchy of activity nodes.
- Develop residential and employment opportunities close to bulk engineering infrastructure.
- Eradicate basic services backlogs.
- Sustainable land reform along Orange River.
- Upgrade sports and health amenities.
- Employment of renewable energy technology.

The proposed project is aligned to the objectives of the municipal IDP and will therefore contribute to the overall mission of the Municipality.

2.5 STRATEGIC ENERGY PLANNING CONTEXT

THE NATIONAL ENERGY ACT (2008)

The National Energy Act was promulgated in 2008 (Act No. 34 of 2008). The National Energy Act aims to ensure that diverse energy resources are available, in sustainable quantities, and at affordable prices, to the South African economy in support of economic growth and poverty alleviation, taking into account environmental management requirements and interactions amongst economic sectors.

The main objectives of the act-

- Ensure uninterrupted supply of energy to the Republic;
- Promote diversity of supply of energy and its sources;
- Facilitate effective management of energy demand and its conservation;
- Promote energy research;
- Promote as appropriate standards and specifications for the equipment, systems and processes used for producing, supplying and consuming energy;
- Ensure collection of data and information relating to energy supply, transportation and demand;
- Provide for optimal supply, transformation, transportation, storage and demand of energy that are planned, organised and implemented in accordance with a balanced consideration of security of supply, economics, consumer protection and a sustainable development;
- Provide for certain safety, health and environment matters that pertain to energy;
- Facilitate energy access for improvement of the quality of life of the people of Republic;
- Commercialise energy-related technologies;
- Ensure effective planning for energy supply, transportation and consumption; and
- Contribute to sustainable development of South Africa's economy.

The Act provides the legal framework which supports the development of renewable energy facilities for the greater environmental and social good.

THE ELECTRICITY REGULATION ACT, 2006 (ACT NO. 4 OF 2006), AS AMENDED

The National Energy Regulation Act (2004) is a national legal framework established for the regulation of the electricity supply industry and is enforced by the National Energy Regulator of South Africa (NERSA).

In 2011, the electricity regulation on new generation capacity was published under Section 35(4) of the Electricity Regulation Act, (Act No. 4 of 2006). These regulations apply to the procurement of new generation capacity by organs of state. The objectives of the regulations include:

- To facilitate planning for the establishment of new generation capacity;
- The regulation of entry by a buyer and a generator into a power purchase agreement;
- To set minimum standards or requirements for power purchase agreements;
- The facilitation of the full recovery by the buyer of all costs efficiently incurred by it under, or in connection with, a power purchase agreement including a reasonable return based on the risks assumed by the buyer thereunder and to ensure transparency and cost reflectivity in the determination of electricity tariffs; and

- The provision of a framework for implementation of an Independent Power Producer (IPP) procurement programme and the relevant agreements concluded.

The Act establishes a National Energy Regulator as the custodian and enforcer of the National Electricity Regulatory Framework. The Act also provides for licenses & registration as the manner in which generation, transmission, distribution, trading & the import & export of electricity are regulated.

INTEGRATED RESOURCE PLAN 2010-2030

The Department of Energy (DoE) published the Integrated Resource Plan (IRP) in March 2011 to cover the period of 2010 - 2030. The IRP is a medium-long term plan which is aimed at providing help and support for the direct expansion of electricity supply including private and own generation and power purchases from regional projects. This plan identifies the need for 300MW of additional PV capacity to be added every year from 2012 until 2024 with a further 4500MW to be added in the years thereafter up to 2030. This amounts to a total of 8.4GWp by 2030.

The overall objectives of the IRP are to evaluate the security of supply, and determine the least-cost supply option through the consideration of various demand side management and supply-side options. In addition, the IRP aims to provide information on the opportunities for investment into new power generating projects.

STRATEGIC INTEGRATED PROJECTS

The South African Government adopted a National Infrastructure Plan in 2012, with the aim of transforming the economic landscape of South Africa, create significant numbers of new jobs, and strengthen the delivery of basic services. It outlines the challenges and enablers which needs to be addressed in the building and developing of infrastructure. The Presidential Infrastructure Coordinating Commission (PICC) was established by the Cabinet to integrate and coordinate the long-term infrastructure build.

Under the guidance of the PICC, 18 Strategic Infrastructure Projects (SIPs) have been developed through the integration of more than 150 of the individual Infrastructure Plans into one coherent package. The SIPs present five core functions namely to unlock opportunity, transform the economic landscape, create new jobs, strengthen the delivery of basic services, and support the integration of African Economies.

SIPs 8 and 9 of the energy SIPs supports the development of the solar energy facilities which is as follows:

- SIP 8: Green energy in support of the South African economy: Support sustainable green energy initiatives on a national scale through a diverse range of clean energy options envisaged in the Integrated Resource Plan (IRP 2010) and supports bio-fuel production facilities.
- SIP 9: Electricity generation to support socio-economic development: Accelerate the construction of new electricity generation capacity in accordance with the IRP 2010 to meet the needs of the economy and address historical imbalances. Monitor implementation of major projects such as new power stations: Medupi, Kusile and Ingula.

WHITE PAPER ON THE RENEWABLE ENERGY POLICY OF THE REPUBLIC OF SOUTH AFRICA (2003)

In response to overexploitation of resources and climate change, South African government ratified the United Nations Framework Convention on Climate Change (UNFCCC) in August 1997 and acceded to the Kyoto Protocol, the enabling mechanism for the convention, in August 2002. In

addition, national response strategies have been developed for both climate change and renewable energy.

The White Paper on Renewable Energy was published in 2003 and supplements the National Energy Policy published in 1998. The White Paper on Renewable Energy sets out the vision, policy principles, strategic goals and objectives of the South African Governments for promoting and implementing renewable energy in South Africa. The paper identifies that the medium and long-term potential of renewable energy is significant and that it is the intention of the government to contribute to the global effort to mitigate greenhouse gas emissions. In addition, it states that there is a need for Government to create an enabling environment through the introduction of fiscal and financial support mechanisms within an appropriate legal and regulatory framework to allow renewable energy technologies to compete with fossil-based technologies.

The objectives of the White Paper are considered in six focal areas:

- Financial instruments;
- Legal instruments,
- Technology development,
- Awareness raising,
- Capacity building and education, and
- Market based instruments and regulatory instruments.

The policy supports the investment in renewable energy facilities as they contribute towards ensuring energy security through the diversification of energy supply, reducing GHG emissions and the promotion of renewable energy sources.

RENEWABLE ENERGY DEVELOPMENT ZONES

The DEA, in consultation with DoE, has been mandated to undertake a Strategic Environmental Assessment (SEA), to identify geographical areas most suitable for the rollout of wind and solar PV energy projects and the supporting electricity grid network. These concentrated development zones are referred to as Renewable Energy Development Zone (REDZs). CSIR have been appointed to manage the wind and solar SEA processes.

It is intended that the introduction of the REDZs will lead to:

- A reduction of potential negative environmental impacts or consequences;
- Synchronisation and streamlining of authorisation and approval processes;
- Potentially attractive incentives; and
- Focused expansion of the South African electricity grid.

The DEA and CSIR have released a map with focus areas best suited for the roll-out of wind and solar photovoltaics projects in South Africa. The proposed project falls just outside the Springbok Wind REDZs, located within the Aggeneys area in the Northern Cape (**Figure 2-2**).

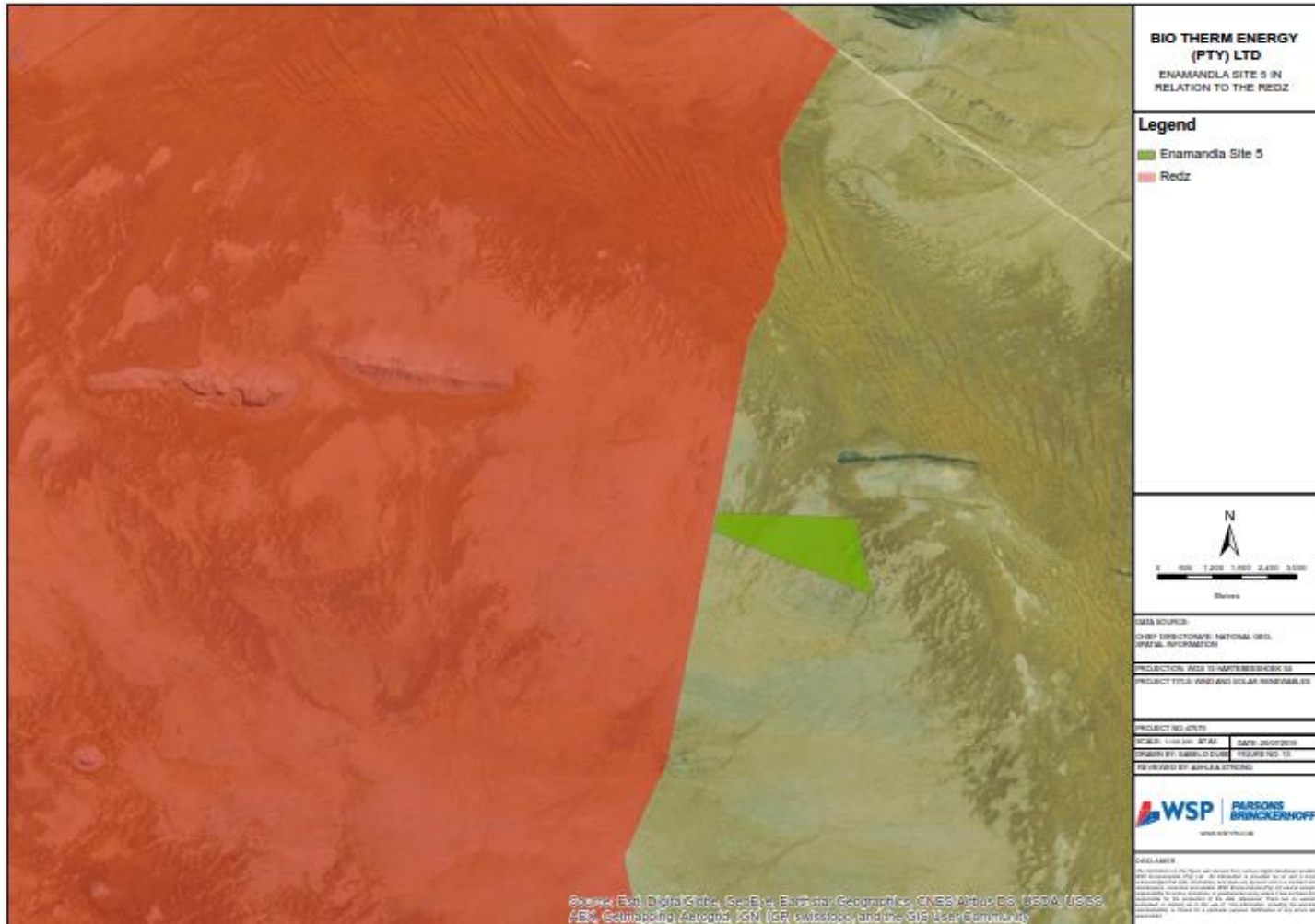

Figure 2-2: The proposed project development site adjacent to the Springbok Wind REDZ

DEPARTMENT OF ENERGY PROCESS FOR INDEPENDENT POWER PRODUCERS

The Renewable Energy Independent Power Producer Procurement Programme (REIPPPP) was established in August 2011 and was designed to contribute towards the target of 3 725 megawatts (MW), generated from Renewable Energy sources, and towards socio-economic and environmentally sustainable growth and to stimulate growth in the renewable energy industry in South Africa.

The Minister has allocated 100 MW of the 3 725 MW to the procurement of small projects which individually have a maximum contracted capacity of 5 MW (DoE). The projects, with a generation capacity of not less than 1 MW and not more than 5 MW, utilising the following technologies shall be considered for the small projects IPP procurement programme:

- Onshore wind;
- Solar photovoltaic;
- Biomass;
- Biogas; and
- Landfill gas.

2.6 SOUTH AFRICAN STANDARDS AND GUIDELINES

NATIONAL ENVIRONMENTAL MANAGEMENT ACT (NO. 107 OF 1998): ENVIRONMENTAL IMPACT ASSESSMENT GUIDELINE FOR RENEWABLE ENERGY PROJECTS

The DEA promulgated the Environmental Impact Assessment Guidelines for Renewable Energy in 2015 to provide guidance on the environmental management legal framework applicable to renewable energy operations and all the role players in the sector. The guideline seeks to identify activities requiring authorisation prior to commencement of that activity, and provide an interface between national EIA regulations and other legislative requirements of various authorities (DEA 2015).

The guideline provides a review of the different renewable energy technologies types, a summary of the potential impacts of each of the technology types and the authorisation process that will need to be followed as well as an overview of some good industry practice mitigation practices that may be applicable to each technology.

2.7 INTERNATIONAL STANDARDS AND GUIDELINES

IFC PERFORMANCE STANDARDS

The International Finance Corporation (IFC) is an international financial institution that offers investment, advisory, and asset management services to encourage private sector development in developing countries. The IFC is a member of the World Bank Group and is headquartered in Washington, D.C., United States. It was established in 1956 as the private sector arm of the World Bank Group to advance economic development by investing in strictly for-profit and commercial projects that purport to reduce poverty and promote development.

The IFC's stated aim is to create opportunities for people to escape poverty and achieve better living standards by mobilizing financial resources for private enterprise, promoting accessible and competitive markets, supporting businesses and other private sector entities, and creating jobs and delivering necessary services to those who are poverty-stricken or otherwise vulnerable. Since 2009, the IFC has focused on a set of development goals that its projects are expected to target.

Its goals are to increase sustainable agriculture opportunities, improve health and education, increase access to financing for microfinance and business clients, advance infrastructure, help small businesses grow revenues, and invest in climate health.

The IFC is owned and governed by its member countries, but has its own executive leadership and staff that conduct its normal business operations. It is a corporation whose shareholders are member governments that provide paid-in capital and which have the right to vote on its matters. Originally more financially integrated with the World Bank Group, the IFC was established separately and eventually became authorized to operate as a financially autonomous entity and make independent investment decisions. It offers an array of debt and equity financing services and helps companies face their risk exposures, while refraining from participating in a management capacity. The corporation also offers advice to companies on making decisions, evaluating their impact on the environment and society, and being responsible. It advises governments on building infrastructure and partnerships to further support private sector development.

The IFC's Sustainability Framework articulates the Corporation's strategic commitment to sustainable development, and is an integral part of IFC's approach to risk management. The Sustainability Framework comprises IFC's Policy and Performance Standards on Environmental and Social Sustainability, and IFC's Access to Information Policy. The Policy on Environmental and Social Sustainability describes IFC's commitments, roles, and responsibilities related to environmental and social sustainability. IFC's Access to Information Policy reflects IFC's commitment to transparency and good governance on its operations, and outlines the Corporation's institutional disclosure obligations regarding its investment and advisory services. The Performance Standards are directed towards clients, providing guidance on how to identify risks and impacts, and are designed to help avoid, mitigate, and manage risks and impacts as a way of doing business in a sustainable way, including stakeholder engagement and disclosure obligations of the client in relation to project-level activities. In the case of its direct investments (including project and corporate finance provided through financial intermediaries), IFC requires its clients to apply the Performance Standards to manage environmental and social risks and impacts so that development opportunities are enhanced. IFC uses the Sustainability Framework along with other strategies, policies, and initiatives to direct the business activities of the Corporation in order to achieve its overall development objectives. The Performance Standards may also be applied by other financial institutions.

Together, the eight Performance Standards establish standards that the client is to meet throughout the life of an investment by IFC:

- Performance Standard 1: Assessment and Management of Environmental and Social Risks and Impacts;
- Performance Standard 2: Labour and Working Conditions;
- Performance Standard 3: Resource Efficiency and Pollution Prevention;
- Performance Standard 4: Community Health, Safety, and Security;
- Performance Standard 5: Land Acquisition and Involuntary Resettlement;
- Performance Standard 6: Biodiversity Conservation and Sustainable Management of Living Natural Resources;
- Performance Standard 7: Indigenous Peoples; and
- Performance Standard 8: Cultural Heritage.

EQUATOR PRINCIPLES

The Equator Principles (EPs) is a risk management framework, adopted by financial institutions, for determining, assessing and managing environmental and social risk in projects and is primarily intended to provide a minimum standard for due diligence to support responsible risk decision-

making. The EP apply globally, to all industry sectors and to four financial products 1) Project Finance Advisory Services 2) Project Finance 3) Project-Related Corporate Loans and 4) Bridge Loans. The relevant thresholds and criteria for application is described in detail in the Scope section of the EP. Currently 84 Equator Principles Financial Institutions (EPFIs) in 35 countries have officially adopted the EPs, covering over 70 percent of international Project Finance debt in emerging markets. EPFIs commit to implementing the EP in their internal environmental and social policies, procedures and standards for financing projects and will not provide Project Finance or Project-Related Corporate Loans to projects where the client will not, or is unable to, comply with the EP.

While the EP are not intended to be applied retroactively, EPFIs may apply them to the expansion or upgrade of an existing project where changes in scale or scope could result in significant environmental and social risks and impacts, or significantly change the nature or degree of an existing impact.

The EPs have greatly increased the attention and focus on social/community standards and responsibility, including robust standards for indigenous peoples, labour standards, and consultation with locally affected communities within the Project Finance market. They have also promoted convergence around common environmental and social standards. Multilateral development banks, including the European Bank for Reconstruction & Development and export credit agencies through the Organisation for Economic Co-operation and Development (OECD) Common Approaches are increasingly drawing on the same standards as the EPs.

The EPs have also helped spur the development of other responsible environmental and social management practices in the financial sector and banking industry (for example, Carbon Principles in the US, Climate Principles worldwide) and have provided a platform for engagement with a broad range of interested stakeholders, including non-governmental organisations (NGOs), clients and industry bodies.

The Equator Principles include:

- Principle 1: Review and Categorisation
- Principle 2: Environmental and Social Assessment
- Principle 3: Applicable Environmental and Social Standards
- Principle 4: Environmental and Social Management System and Equator Principles Action Plan
- Principle 5: Stakeholder Engagement
- Principle 6: Grievance Mechanism
- Principle 7: Independent Review
- Principle 8: Covenants
- Principle 9: Independent Monitoring and Reporting
- Principle 10: Reporting and Transparency

3 SCOPING METHODOLOGY

The scoping process was initiated in accordance with Appendix 2 of GNR 982 pertaining to applications subject to an S&EIR process.

3.1 APPLICATION

The application phase consisted of the completion the appropriate application form by the EAP and the Proponent as well as the subsequent submission and registration of the application for EA with the DEA. The application form was submitted to DEA on **15 September 2016**.

A DEA reference number will be allocated to this application and will appear in the final scoping report and all subsequent official S&EIA related correspondence with the authorities and the public.

The Final Scoping Report (FSR) must be submitted to the DEA within 44 days of receipt of the application by the DEA.

3.2 BASELINE ENVIRONMENTAL ASSESSMENT

The description of the baseline environment was compiled through a combination of desktop reviews and site investigations. Desktop reviews made use of available information including existing reports, aerial imagery and mapping. Site investigations were undertaken by the specialist team between November 2015 and March 2016 to verify the desktop review information.

3.3 IDENTIFICATION AND EVALUATION OF POTENTIALLY SIGNIFICANT IMPACTS

The main issues and potential impacts associated with the proposed project were determined as both a desktop level based on existing information as well as field work and specialist input. The following methodology was used:

- Identify potential sensitive environments and receptors that may be impacted on by the proposed project
- Identify the type of impacts that are most likely to occur (including cumulative impacts);
- Determine the nature and extent of the potential impacts during the various developmental phases, including, construction, operation and decommissioning;
- Identify potential No-Go areas (if applicable); and
- Summarise the potential impacts that will be considered further in the EIA phase through detailed specialist studies.

Appendix 2 of GNR 982 requires the identification of the significance of potential impacts during scoping. To this end an impact screening tool has been used in the scoping report (**Table 3-1**). The screening tool allows impacts of very low significance to be excluded from the detailed studies in the EIR phase. The screening tool is based on two criteria, namely probability; and, consequence, where the latter is based on general consideration to the intensity, extent, and duration.

The scales and descriptors used for scoring probability and severity are detailed in **Table 3-2** and **Table 3-3** respectively.

Table 3-1: Significance Screening Tool

PROBABILITY SCALE	CONSEQUENCE SCALE			
	1	2	3	4
1	Very Low	Very Low	Low	Medium
2	Very Low	Low	Medium	Medium
3	Low	Medium	Medium	High
4	Medium	Medium	High	High

Table 3-2: Probability Scores and Descriptors

SCORE	DESCRIPTOR
4	Definite: The impact will occur regardless of any prevention measures
3	Highly Probable: It is most likely that the impact will occur
2	Probable: There is a good possibility that the impact will occur
1	Improbable: The possibility of the impact occurring is very low

Table 3-3: Consequence Scores and Descriptors

SCORE	NEGATIVE	POSITIVE
4	Very severe: An irreversible and permanent change to the affected system(s) or party(ies) which cannot be mitigated.	Very beneficial: A permanent and very substantial benefit to the affected system(s) or party(ies), with no real alternative to achieving this benefit.
3	Severe: A long term impacts on the affected system(s) or party(ies) that could be mitigated. However, this mitigation would be difficult, expensive or time consuming or some combination of these.	Beneficial: A long term impact and substantial benefit to the affected system(s) or party(ies). Alternative ways of achieving this benefit would be difficult, expensive or time consuming, or some combination of these.
2	Moderately severe: A medium to long term impacts on the affected system(s) or party(ies) that could be mitigated.	Moderately beneficial: A medium to long term impact of real benefit to the affected system(s) or party(ies). Other ways of optimising the beneficial effects are equally difficult, expensive and time consuming (or some combination of these), as achieving them in this way.
1	Negligible: A short to medium term impacts on the affected system(s) or party(ies). Mitigation is very easy, cheap, less time consuming or not necessary.	Negligible: A short to medium term impact and negligible benefit to the affected system(s) or party(ies). Other ways of optimising the beneficial effects are easier, cheaper and quicker, or some combination of these.

3.4 STAKEHOLDER ENGAGEMENT

AUTHORITY CONSULTATION

A pre-application meeting was held on 23 August 2016 with the DEA in order to discuss the proposed project. The minutes of this meeting are included in **Appendix D**.

The application form was submitted to DEA on **15 September 2016**. In addition, WSP | Parsons Brinckerhoff notified the NC DENC, Khâi-Ma Local and the Namakwa District Municipalities as well as the DWS of the Proposed Project via a notification letter.

STAKEHOLDER IDENTIFICATION

Stakeholders were identified and will continue to be identified through several mechanisms. These include:

- Utilising existing databases from other projects in the area;
- Networking with local business owners, non-governmental agencies, community based organisations, and local council representatives;
- Field work in and around the project area;
- Advertising in the press;
- Placement of community notices;
- Completed comment sheets; and
- Attendance registers at meetings.

All Stakeholders identified to date have been registered on the project stakeholder database. The EAP endeavoured to ensure that individuals/organisations from referrals and networking were notified of the Proposed Project. Stakeholders were identified at the horizontal (geographical) and vertical extent (organisations level). A list of stakeholders captured in the project database is included in **Appendix E**.

STAKEHOLDER NOTIFICATION

NEWSPAPER ADVERTISEMENTS

In accordance with the requirements of GNR 982, the proposed project was advertised in a local and regional newspaper. The purpose of the advertisement was to notify the public about the proposed project and to invite them to register as stakeholders (**Appendix F**). The relevant advertisement dates undertaken during scoping are listed in **Table 3-4**.

Table 3-4: Dates on which the Adverts were published

NEWSPAPER	PUBLICATION DATE
Die Gemsbok	7 September 2016

SITE NOTICES

The official site notices will be erected as per GNR 982 on the boundary fence of the proposed site. In addition, general project notices, announcing the Proposed Project and inviting stakeholders to register, will be placed in and around the project area. Proof of these notices will be included in the FSR.

PUBLIC REVIEW OF THE DRAFT SCOPING REPORT

The DSR will be placed on public review for a period of 30 days from **15 September 2016** to **15 October 2016**, at the following venues:

- Aggeneys Public Library;
- Black Mountain Recreation Club;

→ WSP | Parsons Brinckerhoff Website

All registered stakeholders and authorising/commenting state departments were notified of the public review period as well as the locations of the DSR via fax and email, post, sms, hand-outs and the stakeholder meetings.

The abovementioned plan, for notification and provision of reports, will also be utilised for the review of the EIR once the EIR phase has commenced.

STAKEHOLDER MEETINGS

FOCUS MEETINGS

Informal one-on-one stakeholder meetings will be held, as required, in order to present the proposed project to key stakeholders and to ask the stakeholder to raise concerns or queries. The one-on-one stakeholder meetings will be facilitated at appropriate venues during the DSR review period (30 days). WSP | Parsons Brinckerhoff will facilitate the meetings and will be accompanied by the applicant during all meetings.

PUBLIC MEETINGS

Table 3-5 outlines the meetings that will be held during the DSR review period. The meetings will outline the details of the proposed project and provided opportunities for stakeholders to raise issues, concerns and queries. The meetings will also establish lines of communication between stakeholders and the project team. The meetings will be facilitated by WSP | Parsons Brinckerhoff's EIA team and will be attended by BioTherm representatives. Invitations to the meetings were sent out in the form of faxes, telephone calls, emails and site notices. The minutes of the meetings will be included in the FSR.

Table 3-5: Meetings to be held during the Draft Scoping Report Review Period

DATE	TIME	VENUE
26 September 2016	18:00 – 20:00	Black Mountain Recreation Club

STAKEHOLDER REVIEW PRIOR TO DSR SUBMISSION

The DSR was made available to all stakeholders and authorities on **15 September 2016**, for a 30-day review period. The comments received from stakeholders will be recorded and incorporated into the FSR which will be submitted to the DEA as well as any other relevant commenting authorities including the NC DENC.

COMMENT AND RESPONSE REPORT

All concerns, comments, viewpoints and questions (collectively referred to as 'issues') will be documented and responded to adequately in a Comment and Response Report to be included in the FSR. The Comment and Response Report records the following:

- List of all issues raised;
- Record of who raised the issues;
- Record of where the issues were raised;
- Record of the date on which the issue was raised; and
- Response to the issues.

SUBMISSION AND DECISION-MAKING

The delegated DEA will be allocated 43 days to review the FSR. The FSR will be placed on stakeholder review for a reasonable time period during the DEA's final review and decision-making process. The delegated competent authorities must within this specified timeframe issue a decision on whether to proceed onto the next phase, the EIR phase.

WAY FORWARD

FINAL SCOPING REPORT SUBMISSION

All issues raised during the scoping phase of the proposed project will be incorporated into the FSR and will be addressed during the EIR Phase. Once a decision has been reached, the stakeholders will be informed of the next phase of the public participation process.

ONGOING CONSULTATION AND ENGAGEMENT

In addition to the public documents distributed to stakeholders, there will be ongoing communication between the proponent, the WSP | Parsons Brinckerhoff and stakeholders throughout the S&EIR process. These interactions include the following:

- In addition to the project announcement letters, a letter will be sent out to all registered stakeholders providing them with an update of the proposed project once the FSR has been approved;
- Interactions with stakeholders will take place in English and Afrikaans;
- Feedback to stakeholders, individually and collectively;
- Written responses (email, faxes or letters) will be provided to stakeholders acknowledging issues and providing information requested (dependent on availability); and
- As per the GNR 982, particular attention will be paid to landowners, and neighbouring communities, specifically where literacy levels and language barriers may be an issue.

4 NEED AND JUSTIFICATION

4.1 NATIONAL RENEWABLE ENERGY REQUIREMENT

In 2010 South Africa had 44157MW of power generation capacity installed. Current forecasts indicate that by 2025, the expected growth in demand will require the current installed power generation capacity to be almost doubled to approximately 74,000MW (SAWEA: 2010).

This growing demand, fuelled by increasing economic growth and social development within Southern Africa, is placing increasing pressure on South Africa's existing power generation capacity. Coupled with this, is the growing awareness of environmental impact, climate change and the need for sustainable development. Despite the worldwide concern regarding GHG emissions and climate change, South Africa continues to rely heavily on coal as its primary source of energy. Issues associated with the dependence on coal include:

- The fact that the resource is non-renewable;
- Consumption of coal for use in power generation reduces the availability of coal for other uses; and
- Burning of coal is one of the major producers of carbon dioxide (CO₂), which is commonly accepted as a contributor to climate change, deterioration in urban and rural air pollution and acid rain (Banks and Schaffler, 2006).

These issues associated with the burning of coal as well as the rising prices for other fossil-fuels (such as oil), geopolitical developments and environmental concerns have led to growing demand for renewable energy sources. There is therefore an increasing need to establish a new source of generating power in SA within the next decade.

The use of renewable energy technologies, as one of a mix of technologies needed to meet future energy consumption requirements is being investigated as part of Eskom's long-term strategic planning and research process. It must be remembered that solar energy is plentiful, renewable, widely distributed, clean and reduces greenhouse gas emissions when it displaces fossil-fuel derived from electricity. In this light, renewable solar energy can be seen as desirable.

The South African Government, through the promulgation of the IRP 2010, and incorporated into the REIPPPP implemented by the DoE, has committed to a target of 17.8 GW of renewables by 2030. This means that by 2030 approximately 42% of all new power generation will be derived from renewable energy forms. Currently South Africa is heavily dependent on coal as its primary source of energy. In addition, it contributes towards socio-economic and environmentally sustainable growth, while stimulating the renewable industry in South Africa.

4.2 SOLAR POWER POTENTIAL IN SOUTH AFRICA AND INTERNATIONALLY

Internationally, PV is the fastest-growing power generation technology, while CSP technology is remains less established than other renewable energy markets (REN21: 2015). Solar energy (CSP and PV) is ideally suited for South Africa's climate, as most areas experiences more than 2 500 hours of sunshine per year, and have average solar radiation levels ranging between 4.5 and 6.5kWh/m² in one day (DoE).

The current state of progress with regards to the implementation of renewable energy capacity in South Africa is summarised as follows based on the March 2016 IPPPP 'an Overview' it was reported that by March 2016:

- 31% of the 2020 7GW capacity target and 12% of the 2030 17.8GW target had been procured.
- 6.4GW had been procured from 102 IPPs in Bidding Window 1 to Bidding Window 4, with 2.2GW of the procured capacity already constructed and fully operational.
- Of the 6.4GW procured 22 972 MW of PV has been procured with 965 MW being operational and only 600 MW of CSP has been procured with 200 MW being operational.

4.3 REGIONAL AND SITE SUITABILITY

The proposed project will be located on a 4300 ha property approximately 13km South of Aggeneys on Hartebees Vlei Farm 86. This specific project site has been identified by BioTherm through a pre-feasibility desktop analysis based on the estimation of the solar energy resource as well as weather, dust and dirt effects. The suitability of the Northern Cape Province for solar renewable energy development is based on the following attributes:

- It has the highest solar irradiation potential in South Africa, receiving an annual global horizontal irradiation of approximately 2348 kWh/m²/year and an annual direct normal irradiation of approximately 3042 kWh/ m²/year. This high resource value ensures the best value for money is gained for the economy of South Africa.
- The Northern Cape has one of the largest geographic footprints of all the provinces of South Africa and the smallest population number. In addition to the large surface area and low population density it has limited agricultural potential and exceptionally high radiation levels making particularly suited to power generation through solar energy (REIPPPP: 2016).

Within the Northern Cape region, the reasons for the selection of the specific site by BioTherm is based on the following site selection process summary:

- Grid connection suitability is a key criterion. Long connection lines have increased environmental impacts as well as add increased costs to the project development. The proposed project site has favourable grid connection potential, as the project will connect to the existing Aggeneys MTS Substation located approximately 10 km from the site, The need for an extensive grid network upgrade or long power line runs is therefore mitigated.
- The DoE has introduced REDZs across South Africa following the SEA process undertaken by CSIR. Enamandla PV 5 falls just outside the Spingbok Wind zone within the Aggeneys area of the Northern Cape.
- The project site has a relatively flat topography which is suitable for solar PV development. The project has also been located away from the regional view sheds and mountainous regions where the environmental and visual impacts would be relatively greater.
- From a competition perspective, there are several ongoing EIA processes for renewable energy projects in the region; however only one 40MW project has received preferred bidder designation in the immediate area.
- The project site can be accessed easily via the tarred N14 national road which lies approximately 10 km from the site which connects to the R64 and leads to the R359.

This site was selected based on the above criteria ahead of other regional farms due to the cumulative assessment of all criteria. This internal process ensured that the best practical / technically suitable environmental site option was selected.

Additional information on the site selection process is provided in Section 5.5 (Alternatives).

4.4 LOCAL NEED

The proposed site falls within the Khâi-Ma Local Municipality, which is located within the Namakwa District Municipality.

SOCIO-ECONOMICS

The Northern Cape Provincial Growth and Development Strategy highlights the need to ensure the availability of affordable energy, it also notes that, “development of energy sources such as solar energy, the natural gas fields, bio-fuels, etc., could be some of the means by which economic opportunity and activity is generated in the Northern Cape”. The Northern Cape Provincial SDF (2011) states that the energy sector could benefit the economy significantly through created economic spin-offs or multiplier effects and it is widely acknowledged that the Northern Cape province’s comparative advantage lies, among others, in solar resource. The proposed project is thus expected to contribute to these stated regional economic benefits.

EMPLOYMENT

According to the REIPPPP Focus on Northern Cape Province, Provincial Report 2016, employment creation remains a top priority in the Northern Cape. IPP investments in Bidding Window 1 to Bidding Window 4 within the province alone have contributed new employment opportunities for South African citizens estimated to be more than 66 000 job years¹ over the construction and projected operational life of the plants. Notably, 8 842 or 38% of these new employment opportunities have been retained within the local communities associated with the respective IPP plants. To date, the opportunities for people from local communities have significantly exceeded expectations, achieving 96.4% of what is planned across all 6 Bidding Windows. During the construction phase (approximately 2 – 4 years) the number of people employed on site typically spikes, and then tapers off to a lower and steadier employment number over the extended 20 year operational life of a project. Operational jobs will accrue over 20 years. At this early stage, 913 job years have already been realised by the IPPs that have started operation. Approximately 59% of the total jobs created under the overall REIPPPP in Bidding Window 1 to Bidding Window 4 will be created by IPP projects located in the Northern Cape Province.

Khâi-Ma Local Municipality has a total population of 12 645 people, with an unemployment rate of 22,1 %. Currently there are 5 REIPPPP projects operational within the local municipality. 3 of these projects are PV and 2 are CSP projects. The REIPPPP operational projects have had the following impacts on the local municipality to date:

- Socio-economic development: R 1 023 million (8.6% of the total for the Northern Cape);
- Employment/ Job Creation: R 8 388 million (12.6% of the total for the Northern Cape); and
- Community Trust (community equity/ shareholding): R 4 081 million (22.4% of the total for the Northern Cape).

Based on this data, it is likely that the development of Enamandla PV 5 will contribute to the socio-economic development of the area, as well as to the economic growth within the province as a whole.

¹ Job year = equivalent of a full time employment opportunity for one person for one year.

5

PROJECT DESCRIPTION

5.1 LOCATION OF THE PROPOSED PROJECT

The proposed project is to be developed on the Farm Hartebeest Vlei 86 (SG Code: C0530000000008600000) located approximately 13km southeast of Aggeneys located within the Khâi-Ma Local Municipality under the jurisdiction of the Namakwa District Municipality in the Northern Cape.

The site is considered highly suitable for a solar energy project due to the following:

- Climatic conditions;
- Relief and aspect;
- Land availability; and
- Access to the National Grid through Eskom's Aggeneis Substation.

There are a number of EAs (either issued or in progress) within a 65km radius of the proposed project site. These EAs are illustrated in **Figure 5-1** and detailed in **Table 5-1**. The site is located just outside the Springbok Wind REDZ and is therefore considered to be located within the renewable energy hub that is developing in the Aggeneys Area. The location of Enamandla PV 5 is illustrated in **Figure 5-2**.

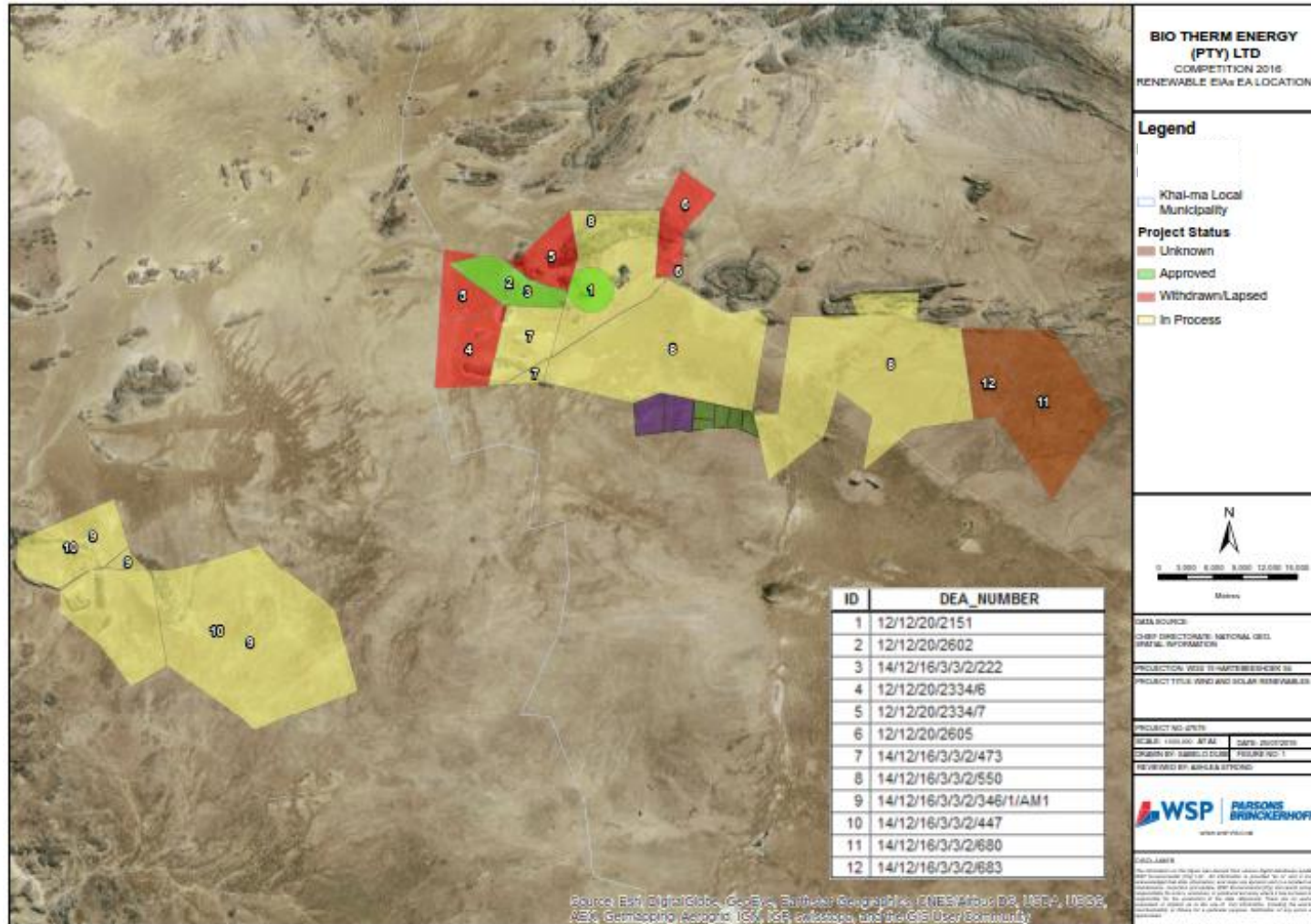

Figure 5-1: The Location of the Existing Environmental Authorisations within 65km of Enamandla PV 5

Table 5-1: Existing Environmental Authorisations within 65km of Enamandla PV 5

DEA REFERENCE NUMBER	EIA PROCESS	PROJECT TITLE	EAP	TECHNOLOGY	MEGAWATT	PROJECT STATUS
14/12/16/3/3/2/346/AM1	Amendment	Construction of the Wind and Photovoltaic (PV) Energy Facilities, including the Construction of the Wind and PV Substations and Gridline Connections, near Springbok, within the Nama-Khoi Local Municipality, Northern Cape Province.	Aurecon South Africa (Pty) Ltd	Onshore Wind and Solar PV	75	In Process
14/12/16/3/3/2/447	S&EIR	Construction of the Wind and Photovoltaic (PV) Energy Facilities, including the Construction of the Wind and PV Substations and Gridline Connections, Near Springbok, within the Nama-Khoi Local Municipality, Northern Cape Province.	Aurecon South Africa (Pty) Ltd	Onshore Wind and Solar PV	1000	In Process
12/12/20/2334/7	S&EIR	Proposed Sato Energy Holdings Photovoltaic Project, Khai Ma Local Municipality, Northern Cape.	SRK Consulting (Pty) Ltd	Solar PV	75	Withdrawn / Lapsed
12/12/20/2602	S&EIR	The Proposed Boesmanland Solar Farm Portion 6 (A Portion Of Portion 2), Farm 62 Zuurwater, Aggeneys, Northern Cape Province.	SRK Consulting (Pty) Ltd	Solar PV	75	Approved
12/12/20/2334/6	S&EIR	Proposed Sato Energy Holdings Photovoltaic Project, Khai Ma Local Municipality, Northern Cape.	SRK Consulting (Pty) Ltd	Solar PV	75	Withdrawn / Lapsed
14/12/16/3/3/2/473	S&EIR	75MW PV plant on the Farm Zuurwater No 62 in the Namakwa District, Northern Cape Province, Phase 4.	SRK Consulting (Pty) Ltd	Solar PV	75	In Process
14/12/16/3/3/2/222	S&EIR	Proposed Boesmanland Solar Farm Portion 6 (A portion of portion 2) Farm 62 Zuurwater, Aggeneys, Northern Cape.	SRK Consulting (Pty) Ltd	Solar PV	75	Approved
12/12/20/2334/7	S&EIR	Proposed Sato Energy Holdings Photovoltaic Project, Khai Ma Local municipality, Northern Cape.	SRK Consulting (Pty) Ltd	Solar PV	75	Withdrawn / Lapsed
14/12/16/3/3/2/550	S&EIR	Proposed Wind Energy Facility and Associated Infrastructure on Namies Wind Farm Pty Ltd, near Aggeneys, Northern Cape Province.	Savannah Environmental Consultants (Pty) Ltd	Onshore Wind	220	In Process

DEA REFERENCE NUMBER	EIA PROCESS	PROJECT TITLE	EAP	TECHNOLOGY	MEGAWATT	PROJECT STATUS
12/12/20/2151	BAR	The Proposed Construction of a Photovoltaic Power Generation Facility within the Black Mountain Mining Area near Aggeneys in the Northern Cape Province.	SRK Consulting (Pty) Ltd	Solar PV	19	Approved
12/12/20/2605	BAR	Proposed Gamsberg Solar Energy Project on Portion 1 of Farm 57 Aroams near Upington, Khâi-Ma Municipality, Northern Cape.	Savannah Environmental Consultants (Pty) Ltd	Solar PV	Unknown	Withdrawn / Lapsed
14/12/16/3/3/2/683	S&EIR	Proposed 75MW Korana Wind Energy Facility, near Poffader in the Northern Cape.	Savannah Environmental Consultants (Pty) Ltd	Onshore Wind	Unknown	Unknown
14/12/16/3/3/2/680	S&EIR	Proposed 140MW Khâi-Mai Wind Energy Facility near Pofadder.	Savannah Environmental Consultants (Pty) Ltd	Onshore Wind	Unknown	Unknown

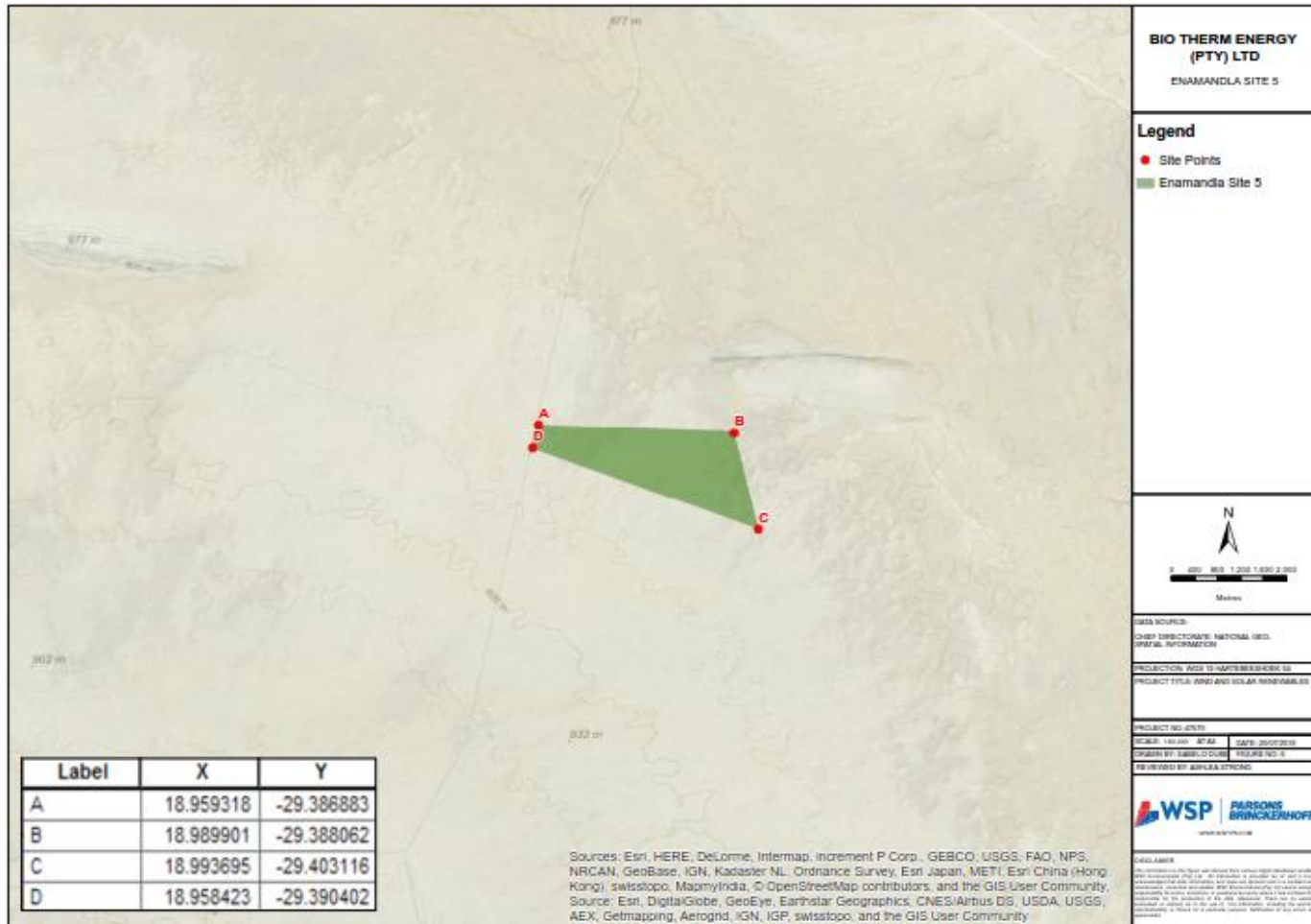

Figure 5-2: The Enamandla PV 5 Project forming part of the greater Enamandla Project

5.2 SOLAR POWER GENERATION PROCESS

South Africa experiences some of the highest levels of solar radiation in the world between 4.5 and 6.5kWh/m²/day) and therefore, possesses considerable solar resource potential for solar power generation.

In terms of large-scale grid connected applications the most commonly used technologies include PV and CSP; these are described in some detail in the following sections:

PHOTOVOLTAIC SYSTEMS

Internationally, PV is the fastest-growing power generation technology and between 2000 and 2009 the installed capacity globally grew on average by 60% per year. By the end of 2016, cumulative global installed PV installations will surpass 310 GW². In South Africa as much as 8 GW of PV is planned to be installed by 2030, with approximately 1GW already installed and operating.

Large-scale or utility-scale PV systems are designed for the supply of commercial power into the electricity grid (**Figure 5-3**). Large-scale PV plants differ from the smaller units and other decentralised solar power applications because they supply power at the utility level, rather than to local users.

PV cells are made from semi-conductor materials that are able to release electrons when exposed to solar radiation. This is called the photo-electric effect. Several PV cells are grouped together through conductors to make up one module and modules can be connected together to produce power in large quantities. In PV technology, the power conversion source is via PV modules that convert light directly to electricity. This differs from the other large-scale solar generation technology such as CSP, which uses heat to drive a variety of conventional generator systems.

Solar panels produce direct current (DC) electricity, therefore PV systems require conversion equipment to convert this power to alternating current (AC), can be fed into the electricity grid. This conversion is done by inverters. **Figure 5-4** provides a flow diagram to illustrate the PV power generation process.

There are two primary alternatives for inverters in large scale systems; being centralised and string inverters.

² <http://www.solarpowerworldonline.com/2016/02/china-u-s-and-japan-to-lead-global-installed-pv-capacity-in-2016/>



Figure 5-3: Large-Scale Photovoltaic Power Generation Facility (Source: www.pv-magazine.com)

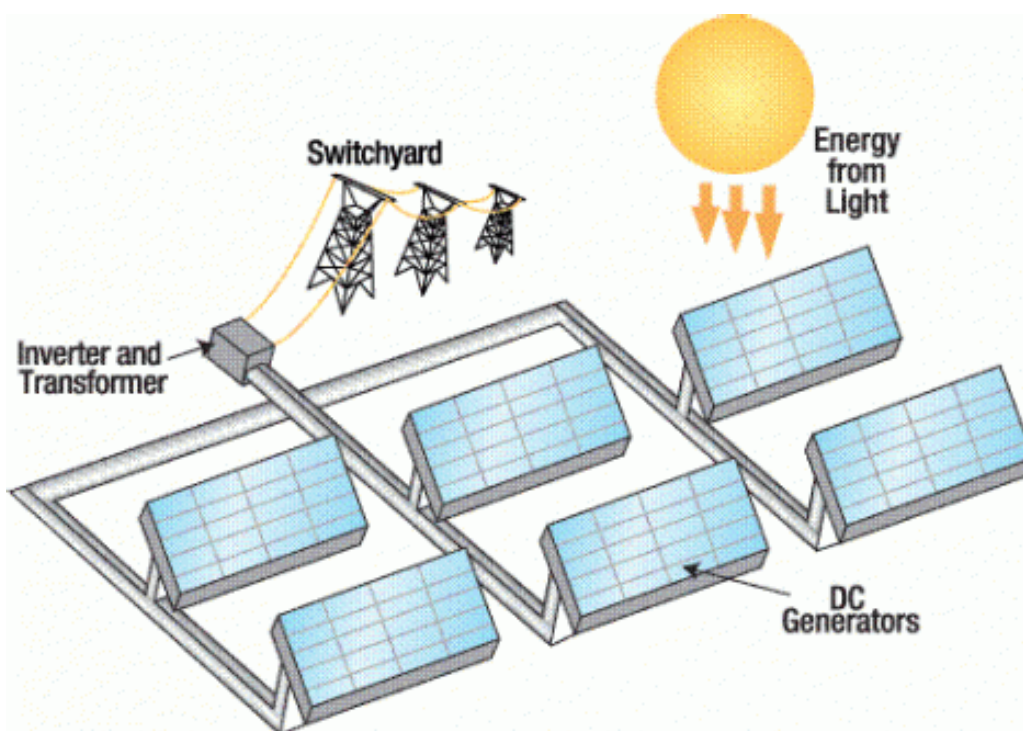

Figure 5-4: Simplified Photovoltaic Power Generation Flow Diagram (Source: www.holbert.faculty.asu.edu)

CONCENTRATED SOLAR POWER

The minimum Direct Normal Radiation (DNR) to justify a CSP plant is 1 800 kWh/m² per year. According to the South African Renewable Resource Database (RRDB), the area exceeding the minimum required DNR in South Africa covers approximately 194 000km². The 2003 Renewable Energy White Paper calculates that South Africa may have a CSP potential of some 65GW, capable of providing 36 000 GWh/year.

Concentrated solar power (also called concentrating solar power, concentrated solar thermal or CSP) systems use mirrors or lenses to concentrate a large area of sunlight, or solar thermal energy, onto a small area. Electrical power is produced when the concentrated light is converted to heat which is used to produce steam, which drives a heat engine, usually a steam turbine, connected to an electrical power generator.

The process of energy conversion in a CSP plant is illustrated in **Figure 5-5**. Since a thermal intermediary is always involved, a conventional steam power turbine generator can be coupled for power generation. Energy storage is possible usually in thermal form (e.g. steam, molten salt).

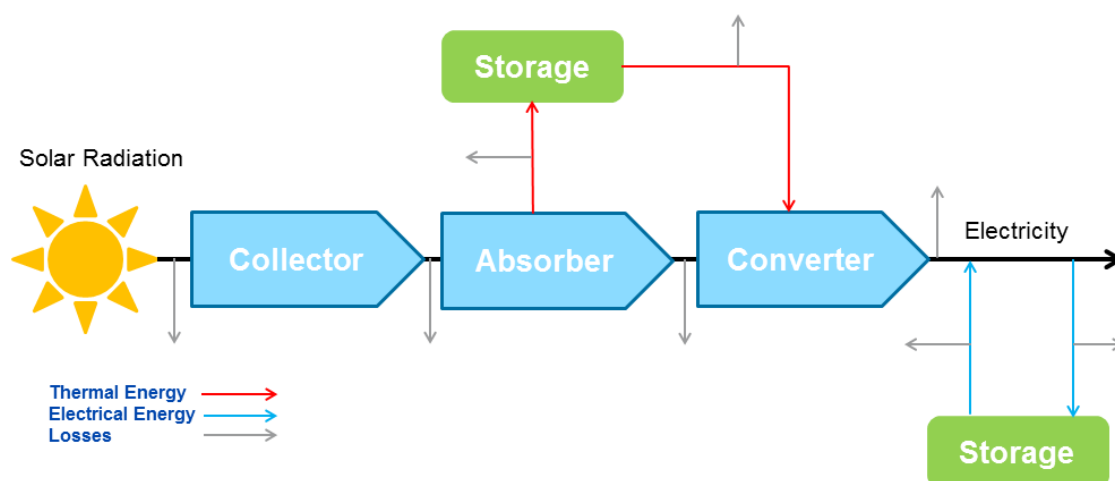

Figure 5-5: Process of Energy Conversion in a CSP Plant

CSP technologies can be categorised by two concentrating methods according to the receiver types - where sunrays are reflected to a line receiver as in parabolic trough (parabolic trough technology) or to a point as in central receiver (central receiver/tower technology).

PARABOLIC TROUGH TECHNOLOGY

In parabolic trough technology, glass mirrors are shaped into the curved parabolic reflectors (troughs) (**Figure 5-6**). Parabolic troughs are usually designed to track the sun along one axis. An absorber tube containing a thermal heat transfer fluid (HTF) is situated along the focal line of the parabolic trough (**Figure 5-7**).

The configuration of a parabolic trough CSP plant with storage is shown in **Figure 5-8** as an example. The HTF is heated to approximately 390°C in the solar field and then circulated through a series of heat exchangers to produce steam (e.g.: 100 bar in Andasol-1, 50 MW, Spain). The steam is converted to electrical energy in the power block, which consists of a conventional steam turbine generator and its associated cooling mechanism.



Figure 5-6: Parabolic Trough (Source: WSP | Parsons Brinckerhoff)



Figure 5-7: Parabolic Trough Absorber Tube (Source: WSP | Parsons Brinckerhoff)

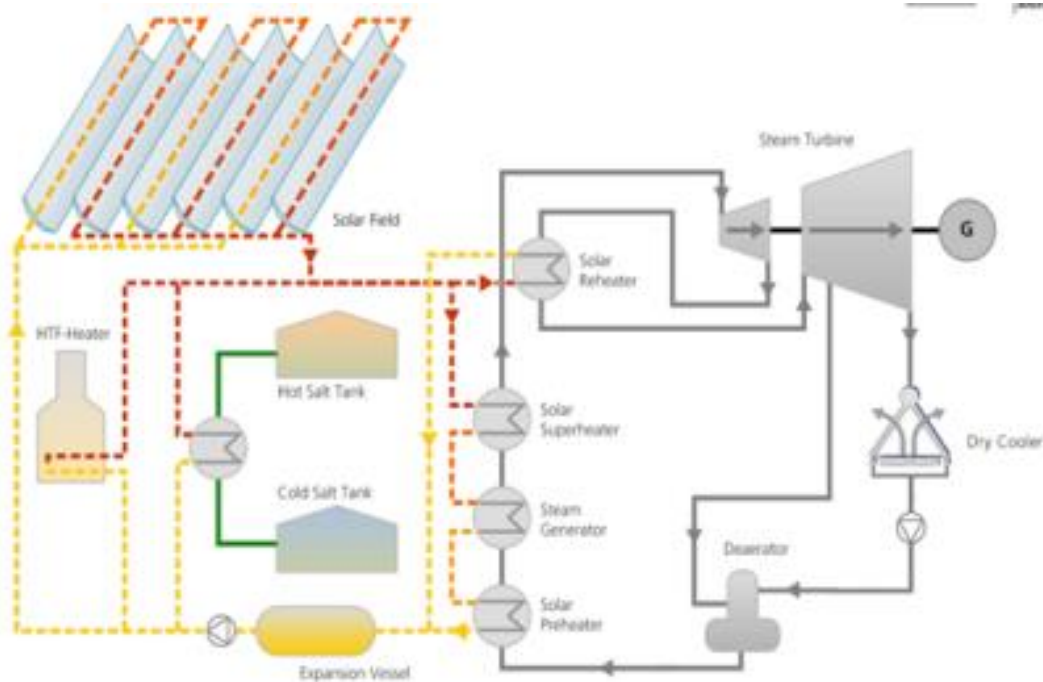

Figure 5-8: Flow Diagram for a Parabolic Trough CSP Facility (Source: www.solarcellcentral.com)

CENTRAL RECEIVER/TOWER TECHNOLOGY

In central receiver technology, sun-tracking mirrors called heliostats (glass mirrors) (**Figure 5-9**) are mounted on a dual-tracking axis which reflects the sunlight to the central receiver (**Figure 5-10**). Heliostats are typically arranged in an elliptical formation around the focal point with the majority of the reflective area focussed to the more effective side of the heliostat field (**Figure 5-11**). Other arrangements are also possible, with rectangular groups of mirrors focused on to a number of smaller central receivers in a modular formation.

In central receiver technology the central receiver is situated on the top of the central tower. This receiver is a heat exchanger which absorbs the concentrated beam radiation, converts it to heat and transfers the heat typically to a HTF which may be thermal oil or molten salt. This is in turn used to generate steam for conventional power generation. **Figure 5-12** provides a flow diagram of the central receiver CSP power generation process (with storage) as an example.



Figure 5-9: Heliostat



Figure 5-10: Central Receiver (Source: www.torresolarenergy.com)



Figure 5-11: Elliptical formation of the Central Tower Solar Field (Source: www.finetubes.co.uk)

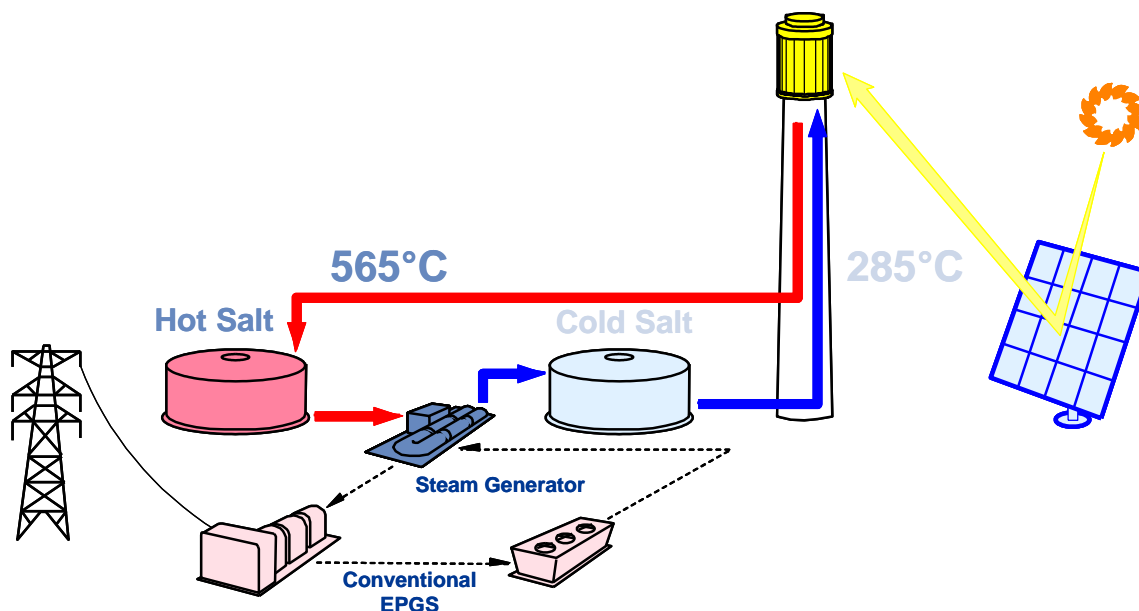

Figure 5-12: Flow Diagram showing the power generation process in a Central Tower CSP facility (Source: www.solarnovus.com)

5.3 PROJECT INFRASTRUCTURE

Enamandla PV 5 will comprise a PV technology, including several arrays of PV solar panels with a combined generating capacity of up to 75MW. A summary of Enamandla PV 5 and its associated infrastructure is included in **Table 5-2**.

Table 5-2: Details of the Proposed PV Plant and Associated Infrastructure

INFRASTRUCTURE	DETAILS / DIMENSIONS
Technology	Photovoltaic Panels with either fixed axis mounting or single axis tracking solutions. Panels will be crystalline silicon or thin film technology
Generation capacity	75MW
Number of panels	Approximately 281,000 to 274,000
Area occupied by each panels	Approximately 2 m ² /panel
Dimensions of solar PV panels	1956mm x 992mm x40mm
Panel Height and orientation	Approximately 4 - 6m
Area of preferred PV array	Approximately 350 Ha
Foundation specifications and dimensions	Concrete or rammed pile
Footprint of Operations and Maintenance building(s)	Approximately 225m ²
Area of preferred construction laydown area	To be confirmed based on the conceptual layout
Temporary and permanent laydown area dimensions	→ Temporary laydown of 5Ha.

INFRASTRUCTURE	DETAILS / DIMENSIONS
	→ Permanent laydown for the containers will be required for the storage of spares, which is to be located close to the Operations and Maintenance building.
Cement Batching Plant	Gravel and sand will be stored in separate heaps whilst the cement will be contained in a silo. The actual mixing of the concrete will take place in the concrete truck. The footprint of the plant will be in the order of 0.25ha. The maximum height of the cement silo will be 20m. This will be a temporary structure during construction.
Access Road	An existing road currently provides access to the site off the N14. It is proposed that this road may be upgraded.
Width of internal roads	Approximately 5m
Length of internal roads	To be confirmed based on the concept layout
Type and height of fencing	Galvanized steel type at approximately 2m high
Sewage	Septic tanks (with portable toilets during the construction phase)
Footprint of internal on-site substation	Internal on-site Substation will occupy a footprint area of approximately 2.25ha
On-site substation capacity	Up to 132kV
Specifications of onsite switching stations, transformers, inverters, onsite cables etc.	There will be an onsite substation connected to the facility power island which is comprised of the steam turbine generator transformer. The power-island will be linked to the onsite substation using suitable underground cables (except where a technical assessment suggests that overhead lines are applicable)..
Width of the powerline servitude	31-36m
Powerline tower types and height	Tower (suspension / strain) / Steel monopole structure, which may be self-support or guyed suspension.
List of additional infrastructure to be built	<ul style="list-style-type: none"> → Access roads and internal roads. → Administration, staff accommodation, control, workshops, water treatment plant and warehouse buildings

5.4 PROPOSED PROJECT DEVELOPMENT ACTIVITIES

DESIGN AND PLANNING PHASE

The main activities during the design and planning phase of Enamandla PV 5 will include the following:

- Undertaking the EIA and obtaining EA.
- Conducting a geotechnical survey to identify any geological and topographical constraints that may affect foundation requirements. In addition to this, the survey will also highlight the availability of onsite construction materials.
- Prior to the finalisation of the design layout (including the solar array and associated infrastructure) a final site survey will be undertaken. The final layout will also take into consideration any environmental sensitivity identified during the EIA phase as well as any specific conditions outlined in the EA (once received).

CONSTRUCTION PHASE

The main activities during the construction phase of the project will include the following:

- **Establishment of an access road to the site** – The PV site will be accessed along an existing road that connects to the N14. This road may require widening to ensure that it is suitable for use. At this stage it is proposed that the road will remain unsurfaced.
- **Establishment** of internal access roads – Internal access roads will be constructed onsite. These roads will be between 4m and 6m in width. The length of these roads will be determined once the design layouts have been finalised. Currently it is proposed that the internal access roads will be unsurfaced and will remain in use during the operational phase.
- **Site Preparation** – Site preparation includes the clearance of vegetation and any bulk earthworks that may be required.
- **Transport of components and equipment to site** – All construction material (i.e. PV support structure materials), machinery and equipment (i.e. graders, excavators, trucks, cement mixers etc.) will be transported to site utilising the national, regional and local road network. Large components (such as substation transformers) may be defined as abnormal loads in terms of the Road Traffic Act (No. 29 of 1989). In such cases a permit may be required for the transportation of these loads on public roads.
- **Establishment of a laydown area on site** – Construction materials, machinery and equipment will be kept at relevant laydown and/or storage areas. A 5Ha laydown area has been proposed for this project. The laydown area will also be utilised for the assembly of the PV panels. The laydown area will limit potential environmental impacts associated with the construction phase by limiting the extent of the activities to one designated area.
- **Erection of PV Panels** – The PV panels will be arranged in arrays. The frames will be fixed onto vertical posts that will be driven into ground utilising the relevant foundation method identified during the geotechnical studies. The height of the structures will be between 4m and 6m.
- **Construction of substation and inverters** – The facility output voltage will be stepped up from medium voltage to high voltage in the transformer. The medium voltage cables will be run underground in the facility (except where a technical assessment suggest that overhead lines are applicable) to a common point before being fed to the onsite substation.
- **Establishment of ancillary infrastructure** – Ancillary infrastructure will include a workshop, storage areas, office and a temporary laydown area for contractor's equipment.
- **Water requirements** – The PV project will require water for dust suppression, concrete batching and potable water during the construction phase. Approximately 17m³ per day will be required during the construction phase. It is understood that this water will be available from Sedibeng Water.
- **Undertake Site Rehabilitation** – The site will be rehabilitated once the construction phase is complete and all construction equipment and machinery have been removed from site.

OPERATIONAL PHASE

Enamandla PV 5 is anticipated to have a minimum life of 20 years. It will operate 7 days a week during daylight hours. While Enamandla PV 5 is considered to be self-sufficient, maintenance and monitoring activities will be required. It is estimated that 7m³ per day of water supplied by Sedibeng Water will be required for the cleaning of panels, maintenance and for potable water for permanent staff.

DECOMMISSIONING PHASE

Following the initial 20 year operational period of Enamandla PV 5, its continued economic viability will be investigated. If it is still deemed viable its life may be extended; if not it will be decommissioned. If it is completely decommissioned, all the components will be disassembled, reused and recycled or disposed of. The site will be returned to its current use i.e. agriculture (grazing).

5.5 PROJECT ALTERNATIVES

In terms of the EIA Regulations, feasible alternatives are required to be considered within the scoping study. All identified, feasible alternatives are required to be evaluated in terms of social, biophysical, economic and technical factors.

A key challenge of the EIA process is the consideration of alternatives. Most guidelines use terms such as 'reasonable', 'practicable', 'feasible' or 'viable' to define the range of alternatives that should be considered. Essentially there are two types of alternatives:

- Incrementally different (modifications) alternatives to the project; and
- Fundamentally (totally) different alternatives to the project.

Fundamentally different alternatives are usually assessed at a strategic level, and EIA practitioners recognise the limitations of project-specific EIAs to address fundamentally different alternatives. Any discussions around this topic have been addressed as part of the Integrated Strategic Electricity Plan (ISEP) undertaken by Eskom, as well as the National Integrated Resource Plan (NIRP) from the National Energy Regulator of South Africa (NERSA). Environmental issues are integrated into the ISEP and the NIRP using the strategic environmental assessment approach, focussing on environmental life-cycle assessments, site-specific studies, water-related issues and climate change considerations.

SITE ALTERNATIVES

DEVELOPMENT AREA SELECTION

The selection of a potential solar project development area includes several key aspects including environmental, solar resource, grid connection suitability as well as competition, topography and access as shown in the process flow diagram in **Figure 5-13**.

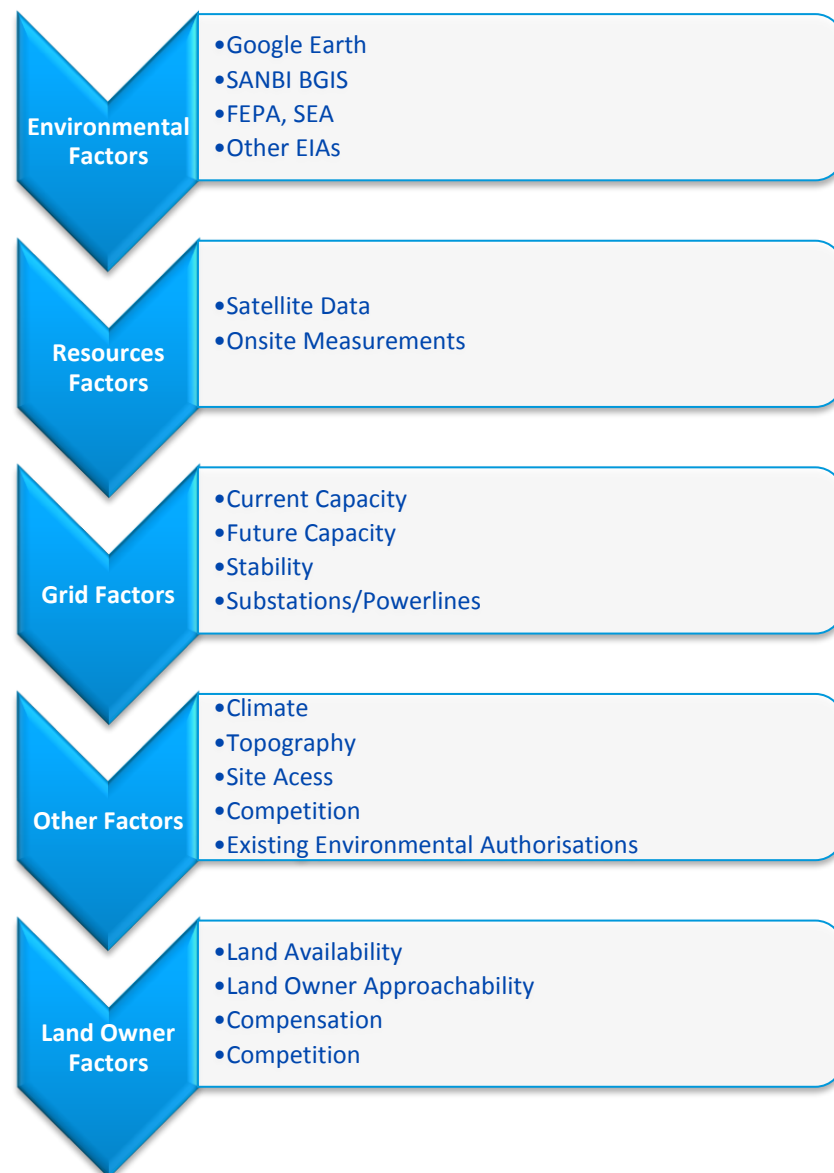

Figure 5-13: Site Selection Process Flow Diagram

ENVIRONMENT

The environment is a key aspect that BioTherm considered when evaluating this potential solar project. The project should be developed in a sustainable and ecologically friendly manner ensuring that its development has the least possible impact on the land on which it will be built. The regional farms were evaluated by BioTherm before the selection of this specific farm and it was concluded that the development on Farm Hartebeest Vlei 86 would result in the least impact of regional fauna and flora. Farms to the north have larger mountainous regions which are deemed sensitive, and other farms show increased vegetation.

SOLAR RESOURCE

The solar resource is one of the main drivers of project viability. This project development area has been identified by BioTherm through a pre-feasibility desktop analysis based on the estimation of the solar energy resource as well as weather, dust and dirt effects. The Northern Cape Province in

South Africa has the highest solar irradiation potential. The project development area receives an annual global horizontal irradiation of approximately 2348 kWh/m²/year and an annual direct normal irradiation of approximately 3042 kWh/m²/year suitable for solar PV. This high resource ensures the best value for money is gained for the economy of South Africa. The general area would experience a similar resource, but as resource is only one driver of site selection, the other aspects should be considered when holistically evaluating a project.

GRID CONNECTION SUITABILITY

Long connection lines have the potential to cause greater environmental impacts, as well as add increased costs to the project development. This project site has good grid connection potential as the project will connect to the existing Aggeneis MTS Substation located approximately 10 km from the site, thereby minimising the need for an extensive grid network upgrade or long power line. In addition, it was identified that there are existing powerline servitudes in close proximity to the site.

TOPOGRAPHY, THE NEIGHBOURING COMPETITION AND ACCESS

The development area has a relatively flat topography which is suitable for the development of Enamandla PV 5. The project has also been located away from the regional view sheds and mountainous regions where it is expected the environmental and visual impacts would be greater.

The region does have several ongoing renewable EIA developments; however only one 40MW project has been selected as a preferred bidder in the region, thus currently there is limited impact of additional projects.

The project development area can be accessed easily via the tarred N14 national road which lies approximately 10km from the project development area. There is an existing gravel road which can be used for direct access to the project development area.

LAND AVAILABILITY

With the high solar resources in the area and good grid connection this area has been targeted for development from Developer for several years. This has resulted in large tracks of land being signed up and hence being unavailable for development. This results in limited land available for development. BioTherm, however, though speaking with local land owners identified parcels of land suitable for development.

STRATEGIC PLANNING CONSIDERATIONS

The project development area, including Enamandla PV 5, falls just outside the Springbok Wind REDZ (**Figure 5-14**). The project development area is also located within a renewable energy hub that has developed in the Aggeneis area.

This project development area was selected based on the above criteria ahead of other regional farms due to the cumulative assessment of all criteria. This internal process ensured that the best practical / technically suitable environmental site option was selected.

Figure 5-15 illustrates the project development area identified through the process described above.



Figure 5-14: Location of the Proposed Site in relation to the Springbok Wind REDZ

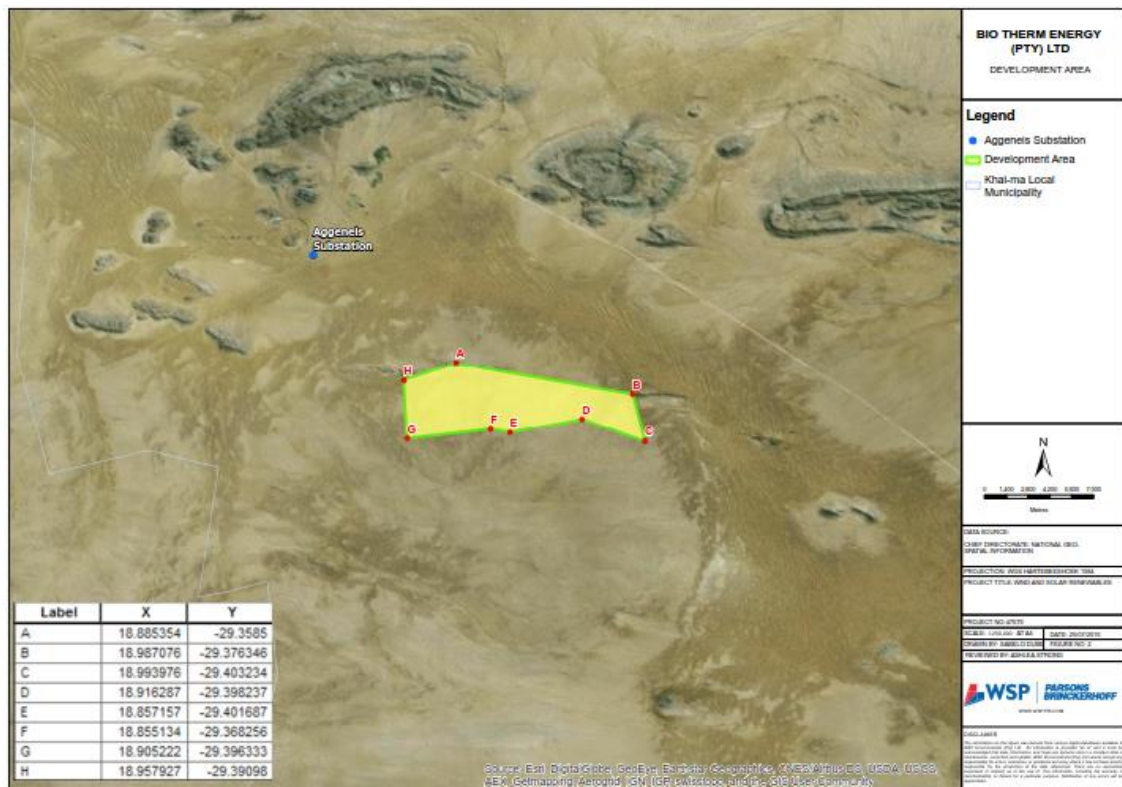

Figure 5-15: Identified Development Area

SITE SELECTION

ALTERNATIVE 1

Enamandla PV 5 is situated within the project development area, which was subjected to the high level site selection process already described. The specialist scoping studies, undertaken between January and March 2016, focused on the identification of potential impacts on the original Enamandla PV 5 site as well as the surrounding areas included in the development area. This report outlines the results of the studies on this original site alternative.

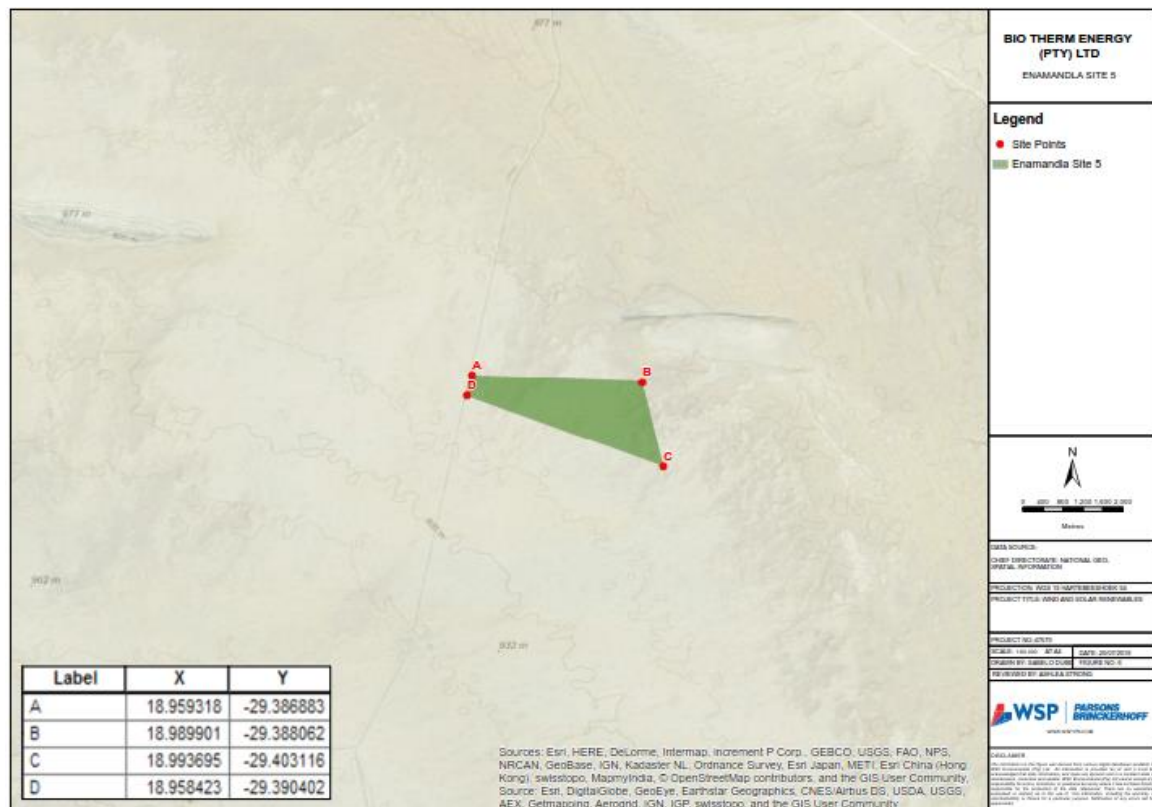

Figure 5-16: Location of the Proposed Enamandla PV 5 (Alternative 1)

ALTERNATIVE 2 (POST SCOPING)

As mentioned above, this project forms part of a larger development proposal that includes both CSP and PV developments. During the project development process, a technical and financial decision was taken to propose CSP Tower technology for the Letsoai CSP projects. Following the determination that the tower system is the preferred technology and most feasible option for the two proposed CSP plants; the 5 proposed PV sites delineations had to be changed due to additional land requirements for the tower system as compared to the parabolic trough system (**Figure 5-17**). The additional space requirements required the development area to be optimized to enable PV capacities of 75MW each, and resulted in

- Enamandla PV 1, 2 and 3 site delineations being revised to fit Enamandla PV 1 east of the second tower facility instead of on the south, and optimizing the development areas Enamandla PV 1 and PV 2 to accommodate this change.
- Enamandla PV 4 and 5 which are located on the far eastern portion of the site also required optimization of the orientation of the sites to release land that would use to accommodate the optimization that was required for Enamandla PV 2 and 3.

→ The overall revised delineation of sites in the development area was necessary to ensure the most optimal grid connection alternatives to Substation 1, 2 and 3 for all the seven (7) proposed facilities.

As a result a new site alternative has been added to this project (**Figure 5-18**). Due to the fact that the impacts across the development area are seen as fairly homogenous, the impacts discussed in this report are seen as representative of alternative 2 that will be assessed in more detail in the EIA phase.

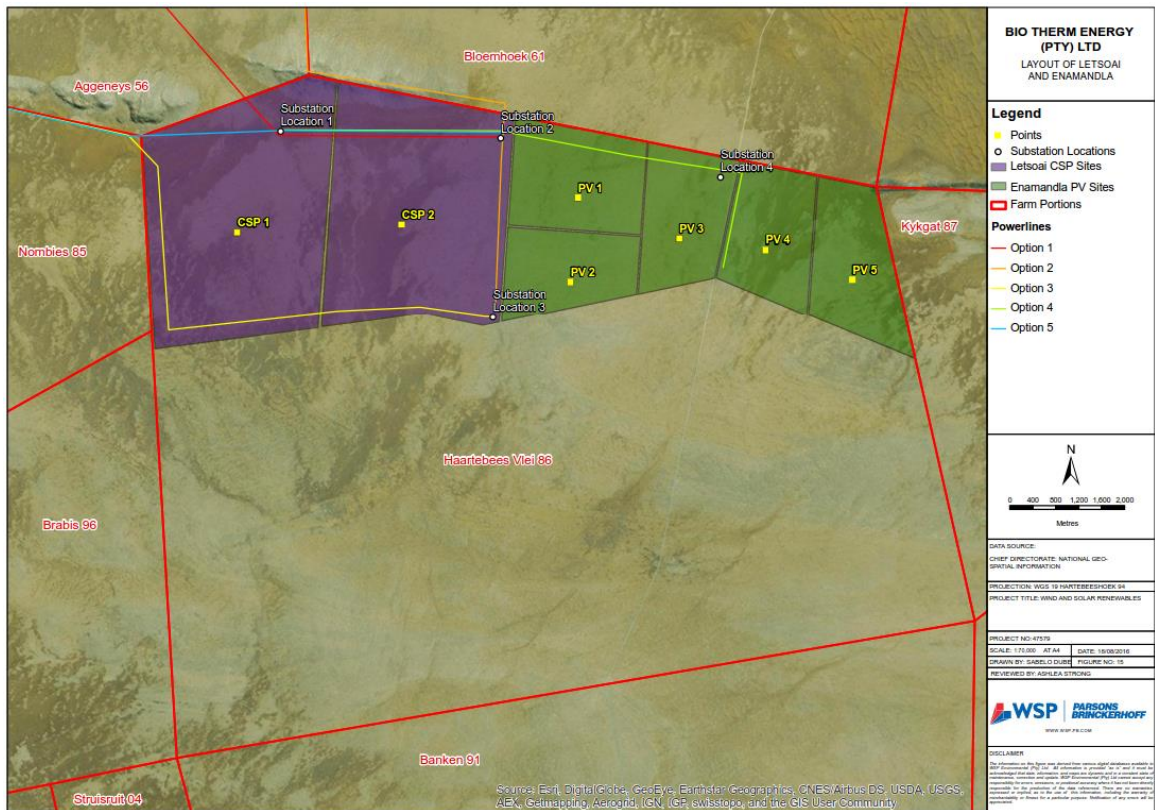

Figure 5-17: New Solar Energy Development Layout

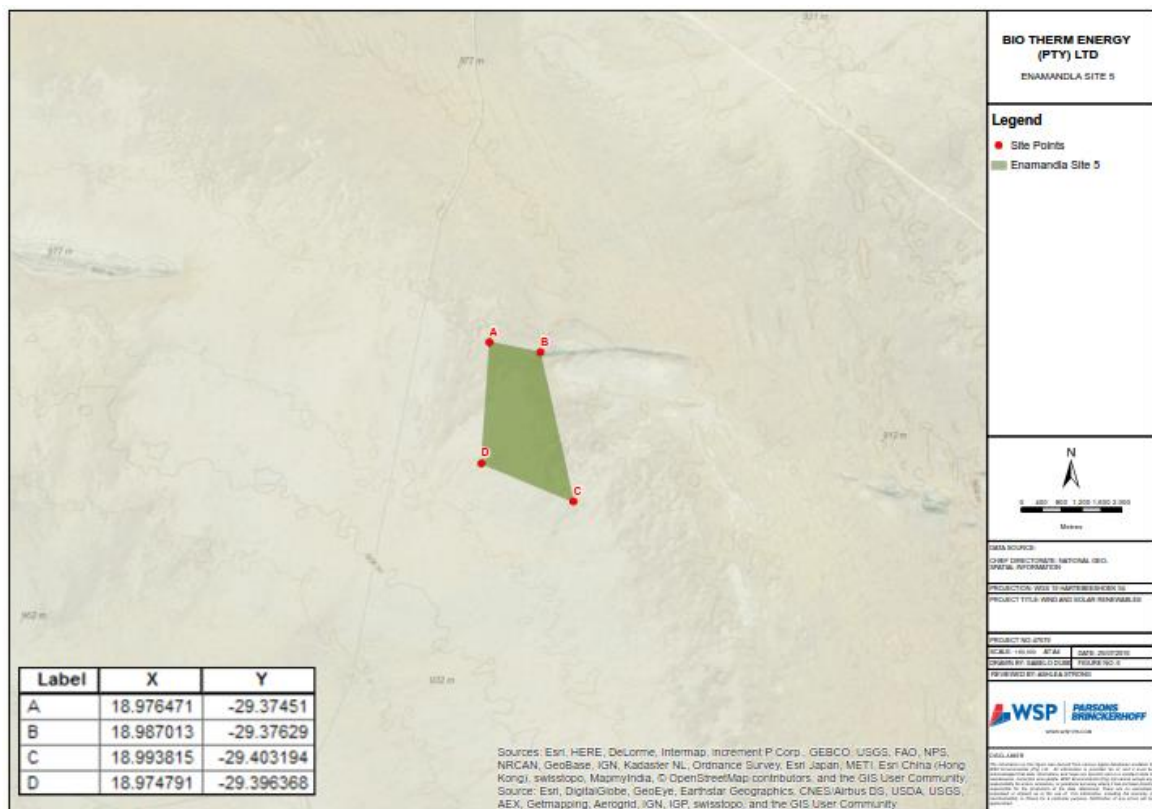

Figure 5-18: Location of the Proposed Enamandla PV 5 (Post Scoping Alternative 2)

TECHNOLOGY ALTERNATIVES

SOLAR POWER GENERATION ALTERNATIVES

Section 3.2 above provided a description of the main solar generating technologies i.e. PV and CSP (including parabolic trough and central receiver) technologies. The technology identified for this project is PV. The advantages and disadvantages of this technology are provided in **Table 5-3**.

Table 5-3: Advantages and Disadvantages of Solar PV generating Technology

ADVANTAGES	DISADVANTAGES
<ul style="list-style-type: none"> → PV panels provide clean energy. During electricity generation there is no emission of harmful greenhouse gasses; → PV cells have a very long lifespan and require minimum upkeep; → V is currently the lowest price solar technology; → Minimal operations and maintenance support staff are required; → A minimal amount of water is required; and → Solar energy does not deplete non-renewable resources such as coal, gas and oil used in 	<ul style="list-style-type: none"> → Some toxic chemicals, like cadmium and arsenic, are used in the PV production process. These environmental impacts are minor and can be easily controlled through recycling and proper disposal; → Solar energy is somewhat more expensive to produce than conventional sources of energy due in part to the cost of manufacturing PV devices and in part to the conversion efficiencies of the equipment. As the conversion efficiencies continue to increase and the manufacturing costs continue to come down, PV will become increasingly cost competitive with conventional fuels;

ADVANTAGES	DISADVANTAGES
<p>conventional thermal power plants; and is therefore sustainable.</p> <p>→ Solar energy is a locally available and thus alleviates the greenhouse gas emissions associated with the transportation of fuel typically required in conventional power plants.</p>	<p>→ Energy storage options (batteries) are expensive;</p> <p>→ There may be significant power output fluctuations due to no inertia in the system;</p> <p>→ PV efficiency is significantly adversely affected at high ambient temperatures; and</p> <p>→ Solar power is a variable energy source, with energy production dependent on the sun. Solar facilities may produce no power at all some of the time, which could lead to an energy shortage if too much of a region's power comes from solar power.</p>

LAYOUT AND DESIGN ALTERNATIVES

No layout or design alternatives are available for assessment at this stage. The area of the site is 354 ha in extent; this can adequately accommodate the 75 MW design capacity of Enamandla PV 5.

The scoping phase aims to identify potentially environmentally sensitive areas within the site which should be avoided by the proposed development. This information will be used to inform the layout and design alternatives for the proposed project.

During the EIA further detailed studies will be undertaken on the areas affected by the proposed layout and design alternatives in order to identify any further areas of sensitivity thereby allowing for further refinement of the final layout and design.

ACCESS ROAD ALTERNATIVES

MAIN ACCESS ROAD

Appropriate access roads will be constructed to link Enamandla PV 5 to the existing road network. At this stage two potential alternatives exist (**Figure 5-19**):

- Alternative 1 - An existing road connects the N14 to the project area. This road may require widening to ensure that it is suitable for use. At this stage it is proposed that the road will remain unsurfaced.
- Alternative 2 – Access to the facility could also potentially be obtained via a new 9.5 km road with a direct access off the N14, however due to the fact that the N14 is a National Route an access application will be required to be submitted to the South African National Roads Agency Limited (SANRAL) and/or the Northern Cape Province and would cause additional environmental impact.

INTERNAL ACCESS ROADS

No alternative internal access routes have been identified at this stage. These will be identified in conjunction with the layout and design alternatives.

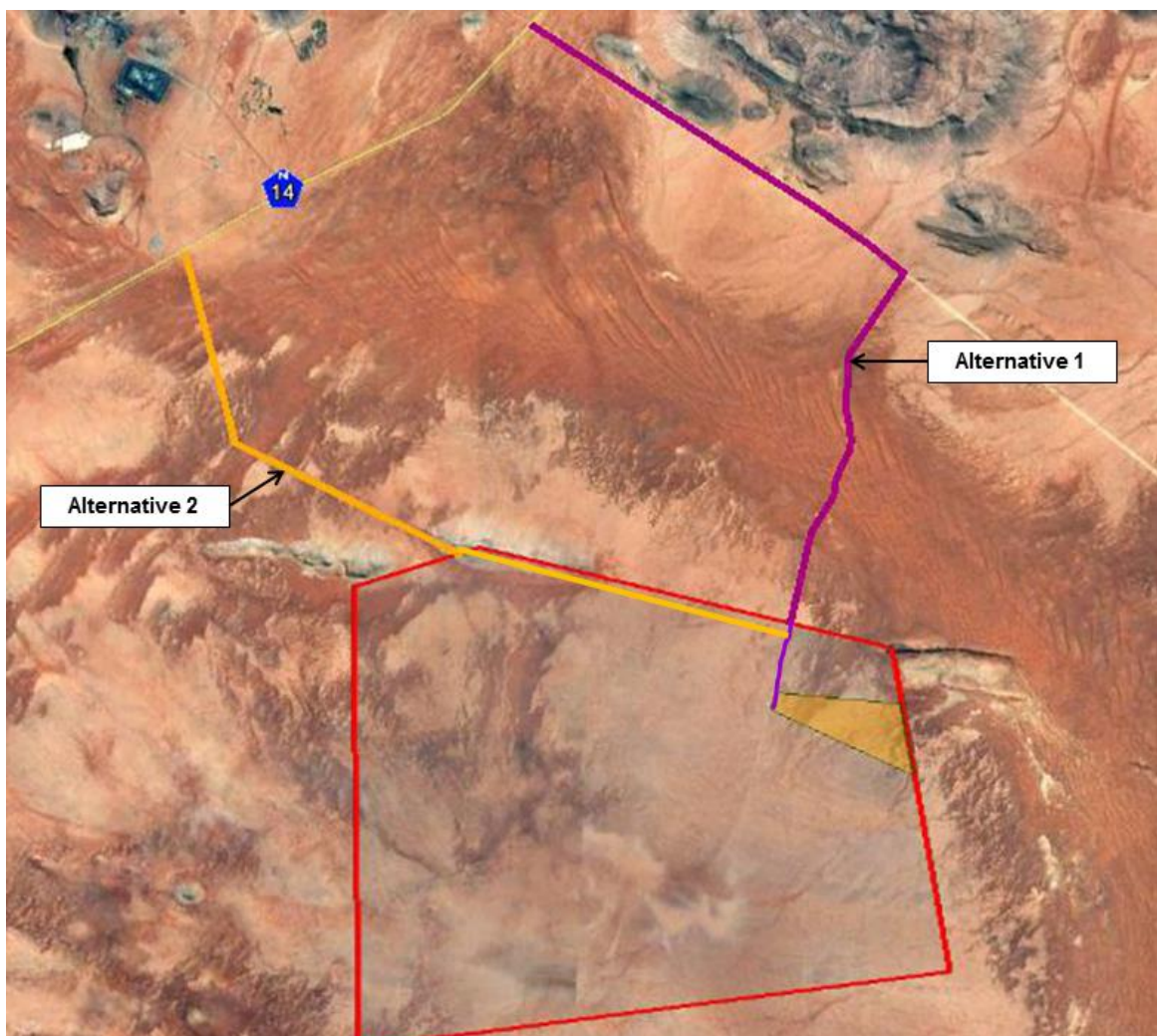

Figure 5-19: Two Alternative Main Access Routes

POWER LINE ALTERNATIVES

The power generated by the steam turbine(s) will be evacuated to the national grid via the new 132kV powerlines. These external high voltage (132kV) powerlines will be identified concurrently with the layout and design alternatives. The following 132kV tower structure alternatives are available for the internal powerlines, these will be assessed during the EIA phase:

- Steel / concrete monopole single circuit structure (**Figure 5-20**);
- Steel / concrete monopole double circuit structure (**Figure 5-21**); and
- H-pole structure (usually wooden poles) (**Figure 5-22**).

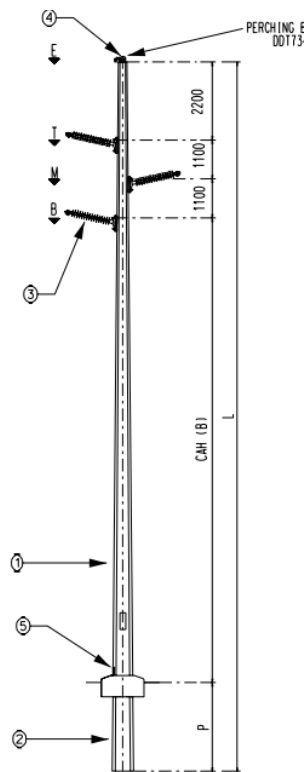

Figure 5-20: Steel / Concrete Monopole Single Circuit Structure

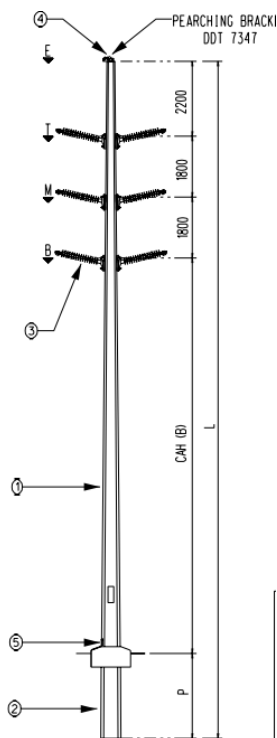

Figure 5-21: Steel / Concrete Monopole Double Circuit Structure

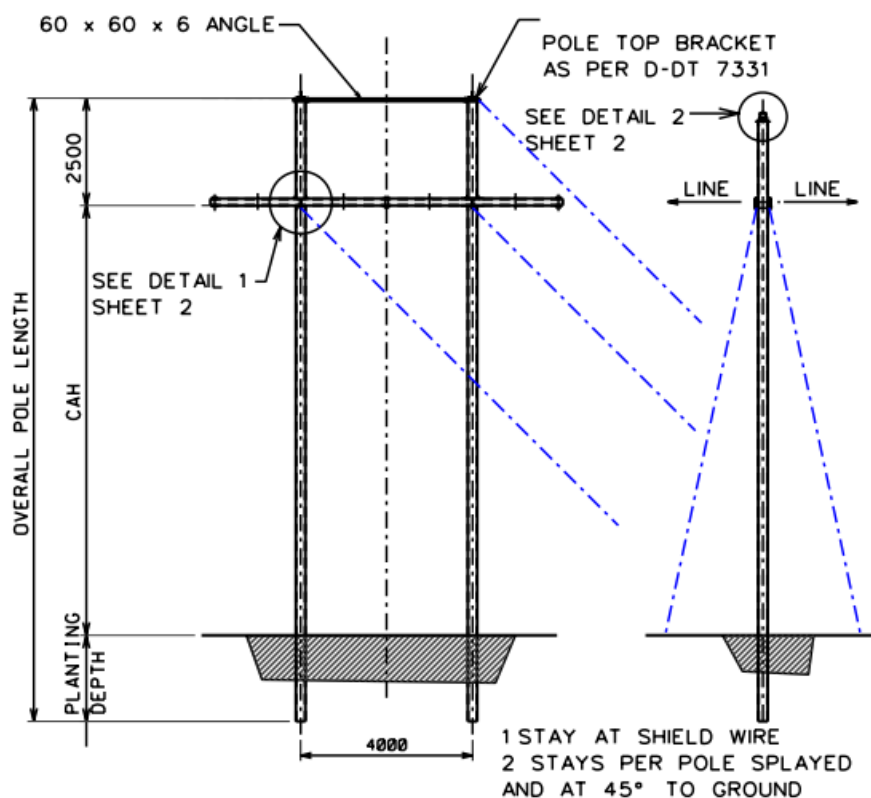

Figure 5-22: H-pole Structure (usually wooden poles)

At the on-site substations voltage will again be stepped up before being fed to Eskom's Aggeny's Substation. Power will be evacuated by one up to 400kV powerline. Alternative powerline corridors have been identified however; they are being assessed in a separated S&EIR process and will therefore not be included in the scope of this assessment.

THE "DO-NOTHING" ALTERNATIVE

The 'do-nothing' alternative is the option of not implementing the proposed project.

South Africa currently relies almost completely on fossil fuels as a primary energy source (approximately 90%) with coal providing 75% of the fossil fuel based energy supply. Coal combustion in South Africa is the main contributor to carbon dioxide emissions, which is the main greenhouse gas that has been linked to climate change.

An emphasis has therefore been placed on securing South Africa's future power supply through the diversification of power generation sources. Furthermore, South Africa would have to invest in a power generation mix, and not solely rely on coal-fired power generation, to honour its commitment made under the Copenhagen Accord and to mitigate climate change challenges. Under the Accord, the country committed to reduce its carbon dioxide emissions by 34% below the "business as usual" level by 2020.

With an increasing demand in energy predicted and growing environmental concerns about fossil fuel based energy systems, the development of large-scale renewable energy supply schemes is strategically important for increasing the diversity of domestic energy supplies and avoiding energy imports in the country.

Without the implementation of this project, the use of renewable options for power supply will be compromised in the future. This has potentially significant negative impacts on environmental and social well-being.

The no-go option is a feasible option; however, this would prevent BioTherm from contributing to the significant environmental, social and economic benefits associated with the development of the renewables sector (see need and justification of the proposed project in Chapter 4). Accordingly, the no-go option is not the preferred option.

6

DESCRIPTION OF THE BASELINE ENVIRONMENT

6.1 TOPOGRAPHY

The topography in the study area is flat, gently sloping from about 920masl to 860masl in a north-easterly direction. The surrounding terrain is generally flat with the Aggeneys se Berge and the Gamsberg Inselberg to the north rising to an elevation of about 1140masl. To the south are flat expansive plains. **Figure 6-1** illustrates the elevation profile of the study area.

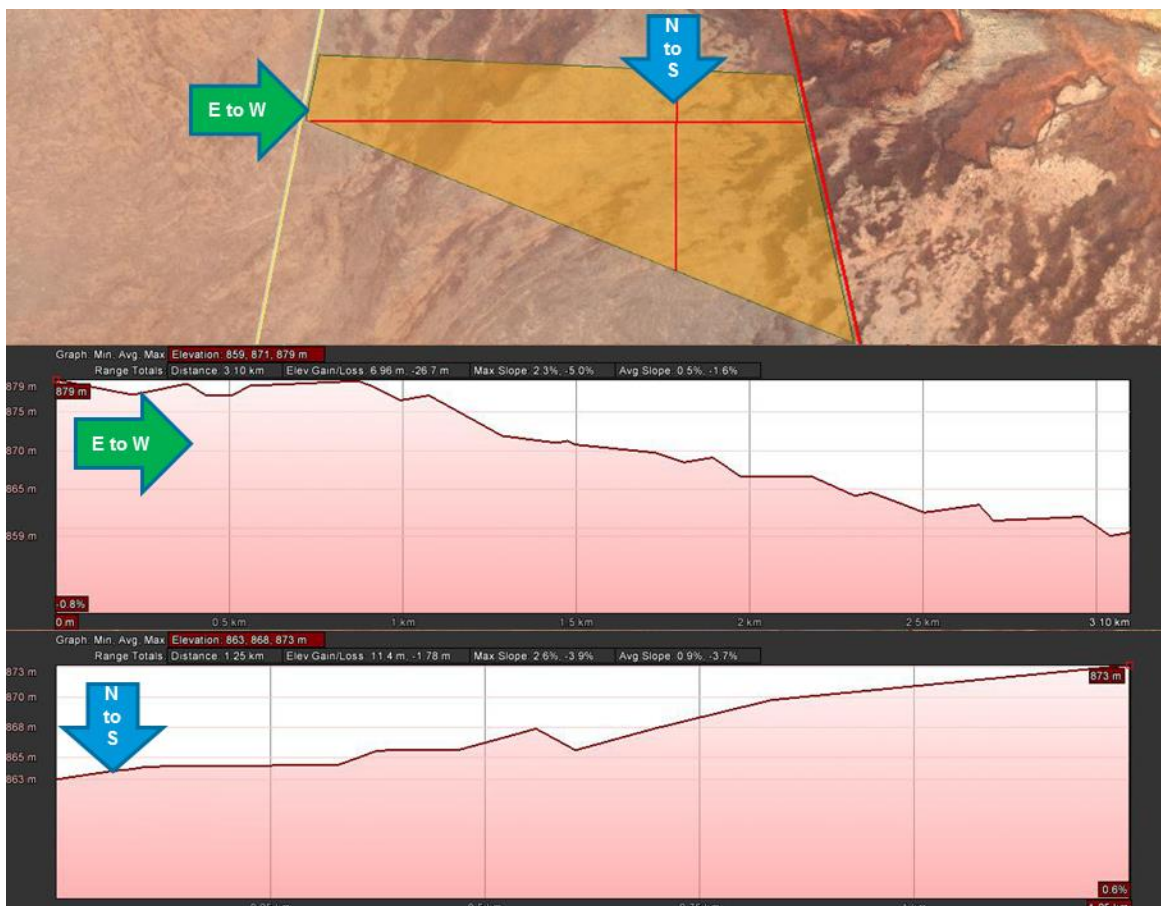

Figure 6-1: Elevation Profile for the Proposed Site

6.2 GEOLOGY

The study area comprises a fairly flat-lying (c. 870 to 920 m amsl), arid area of Bushmanland approximately 20 km southeast of the small town of Aggeneys, Northern Cape. The surface terrain in this region is predominantly sandy to gravelly with low hills and patchy outcrops of basement rocks as well as a number of shallow, ephemeral streams.

The geology of the Aggeneys region is shown on 1: 250 000 geological map 2918 Pofadder (Council for Geoscience, Pretoria) (**Figure 6-2**) (Agenbacht 2007). The scattered basement inliers are composed of a variety of resistant-weathering igneous and high grade metamorphic rocks - mainly

gneisses, schists, quartzites and amphibolites - of Late Precambrian (Mokolian / Mid-Proterozoic) age. These ancient basement rocks are assigned to the Namaqua-Natal Province and are approximately one to two billion years old (Cornell et al. 2006, Moen 2007, Agenbacht 2007). The flatter portions of the study area – including those that will be directly affected by the proposed solar energy facility - are underlain by a spectrum of unconsolidated superficial sediments of Late Cenozoic age. These include Quaternary to Recent sands and gravels of probable braided fluvial or sheet wash origin (Q-s2 in **Figure 6-2**), as well as a veneer of downwasted surface gravels and colluvial (rocky scree) deposits that are not indicated separately on the geological map. The alluvial and colluvial sediments are locally overlain, and perhaps also underlain, by unconsolidated aeolian (i.e. wind-blown) sands of the Gordonia Formation (Kalahari Group) that are Pleistocene to Holocene in age (Q-s1 in **Figure 6-2**). All these superficial sediments can be broadly subsumed into the Late Cretaceous to Recent Kalahari Group, the geology of which is reviewed by Partridge et al. (2006).

An important Cenozoic geological feature in the Aggeneys area is the Koa River Palaeovalley - a defunct south bank tributary of the River Orange of Late Tertiary (Miocene – Pliocene) age that fed into the palaeo-Orange River near Henkries (Malherbe et al. 1986, De Wit 1990, 1993, 1999, De Wit et al. 2000, Partridge et al. 2006). The palaeovalley runs along a SE-NE line just to the northeast of the project area and then turns west across the transmission line project area. It can be readily seen on satellite images where it is marked by intermittent pans and a veneer of orange-brown Kalahari wind-blown sands (arcuate band of yellow Q-s1 on the geological map **Figure 6-2**).

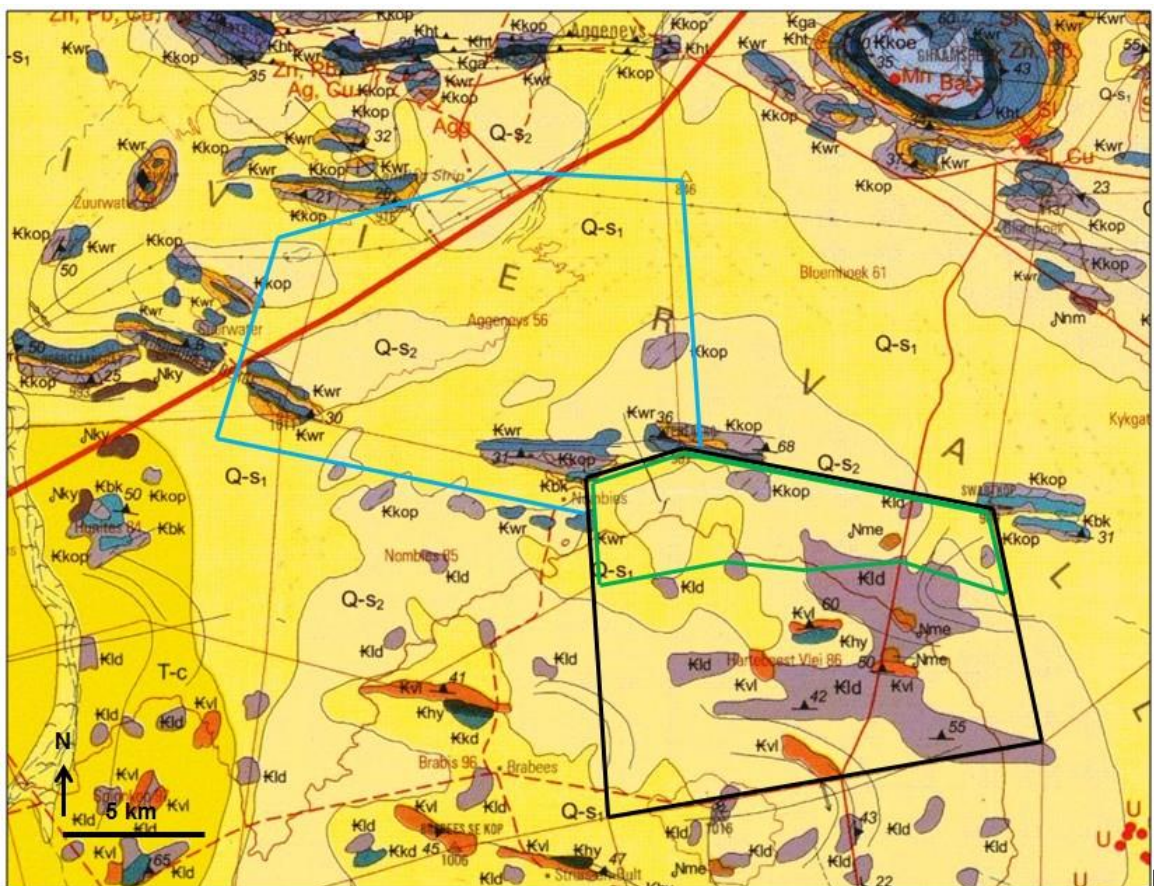

Figure 6-2: Geological Map

6.3 CLIMATE

Aggeneys has an average annual rainfall of around 112mm, with the highest rainfall occurring between January and April. The lowest recorded annual rainfall was in 1992 at approximately 11mm, while the highest recorded rainfall was in 2006, at approximately 220mm.

Average minimum and maximum temperatures in the area are 15°C to 38°C in summer and 0°C to 18°C in winter. The days in the summer are long (sunrise at around 6:00am, sunset close to 8:00pm), and short in the winters (sunrise after 07:30am, sunset before 6:00pm).

Figure 6-3 shows the average temperatures and precipitation for Aggeneys. The "mean daily maximum" (solid red line) shows the maximum temperature of an average day each month of the year. Likewise, "mean daily minimum" (solid blue line) shows the average minimum temperature. Hot days and cold nights (dashed red and blue lines) show the average of the hottest day and coldest night of each month of the last 30 years.

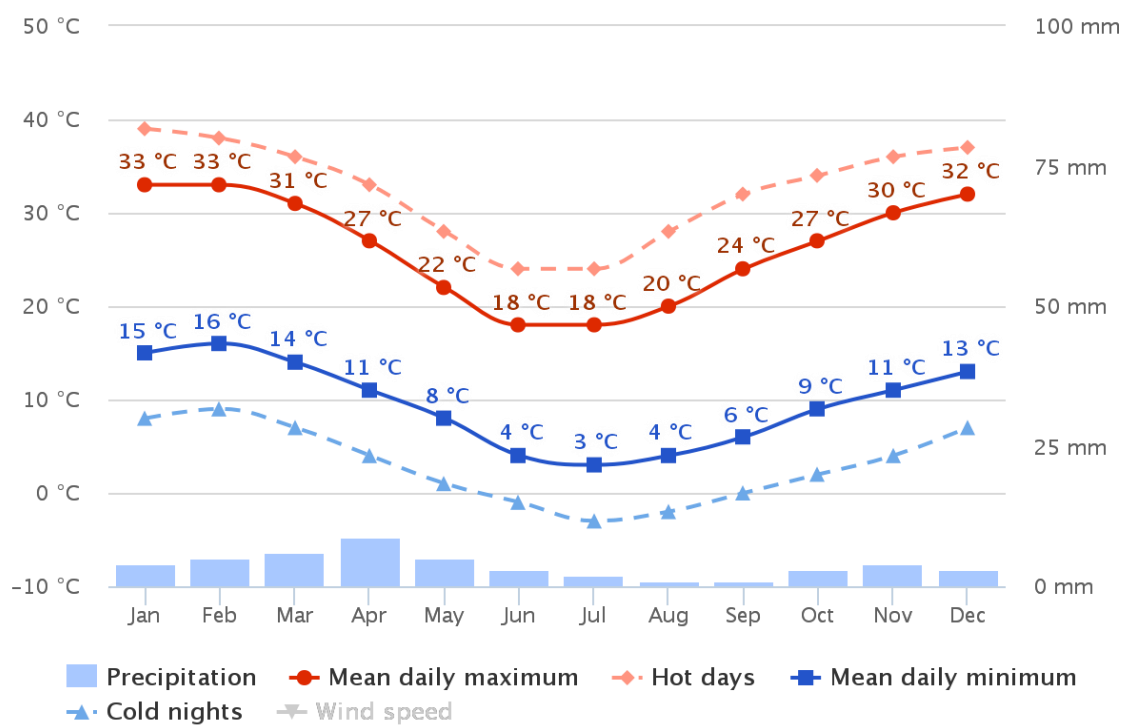

Figure 6-3: Average Temperatures and Precipitation for Aggeneys

Figure 6-4 shows the monthly number of sunny, partly cloudy, overcast and precipitation days. Days with less than 20% cloud cover are considered as sunny, with 20-80% cloud cover as partly cloudy and with more than 80% as overcast.

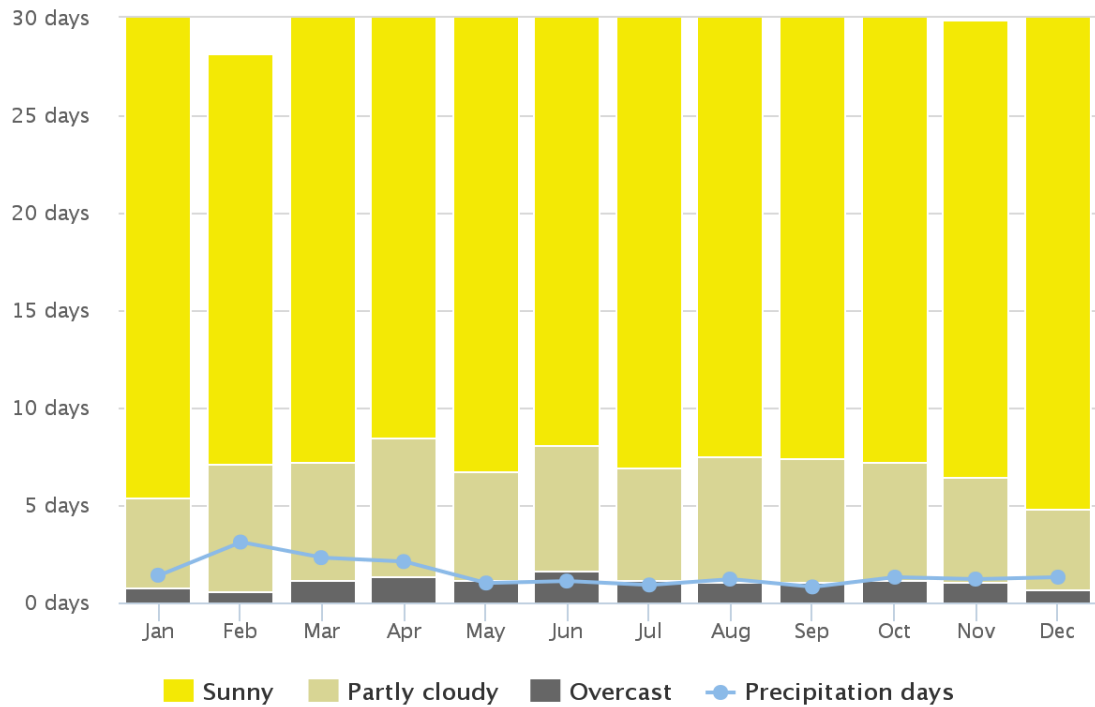

Figure 6-4: The number of Sunny, Partly Cloudy and Overcast Days for Aggeneys

Figure 6-5 shows the maximum temperatures for Aggeneys. The graph displays how many days per month reach certain temperatures.

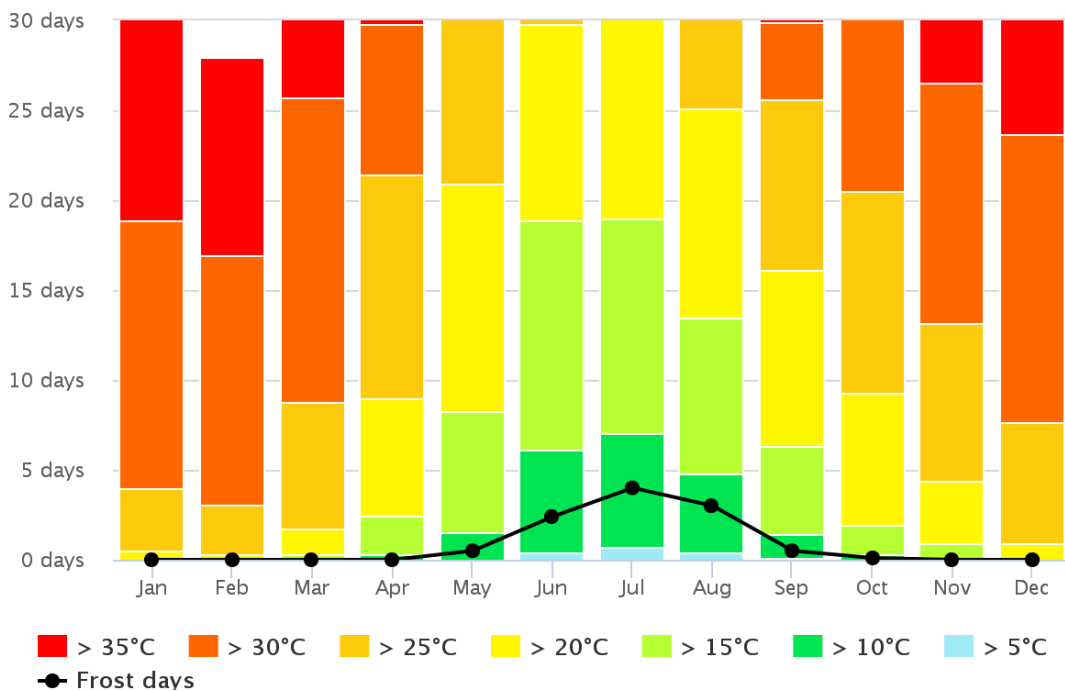

Figure 6-5: Maximum Temperatures for Aggeneys

Figure 6-6 shows the precipitation diagram for Aggeneys. This graph illustrates how many days per month certain precipitation amounts are reached.

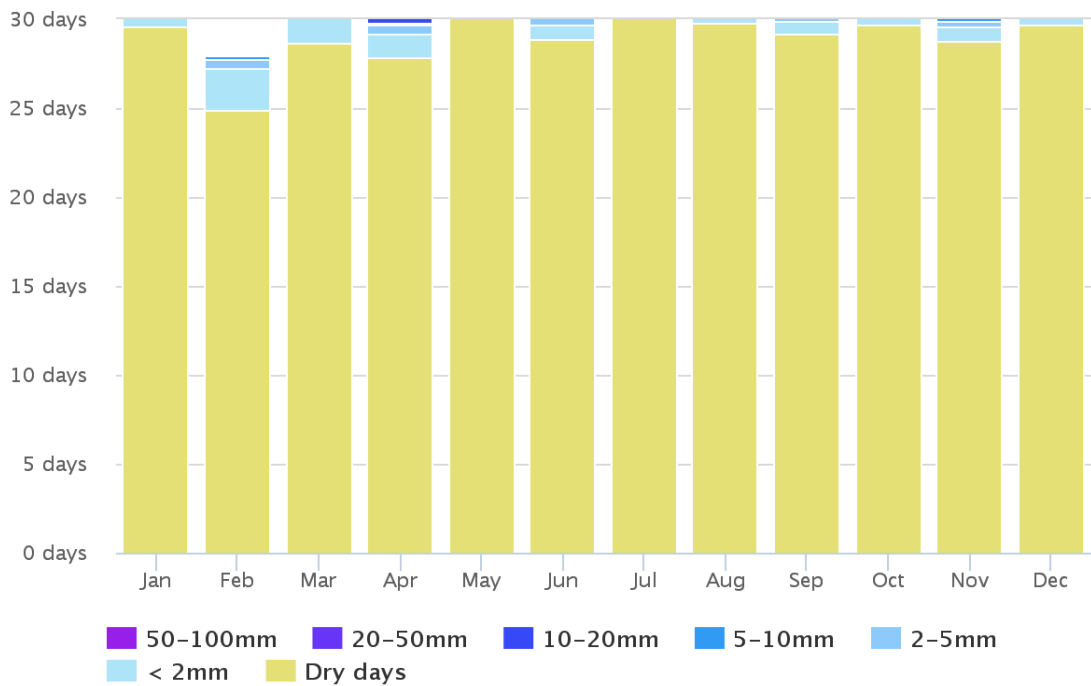

Figure 6-6: Precipitation Days for Aggeneys

Figure 6-7 shows the average wind speeds for Aggeneys. The graph shows how many days within one month can be expected to reach certain wind speeds.

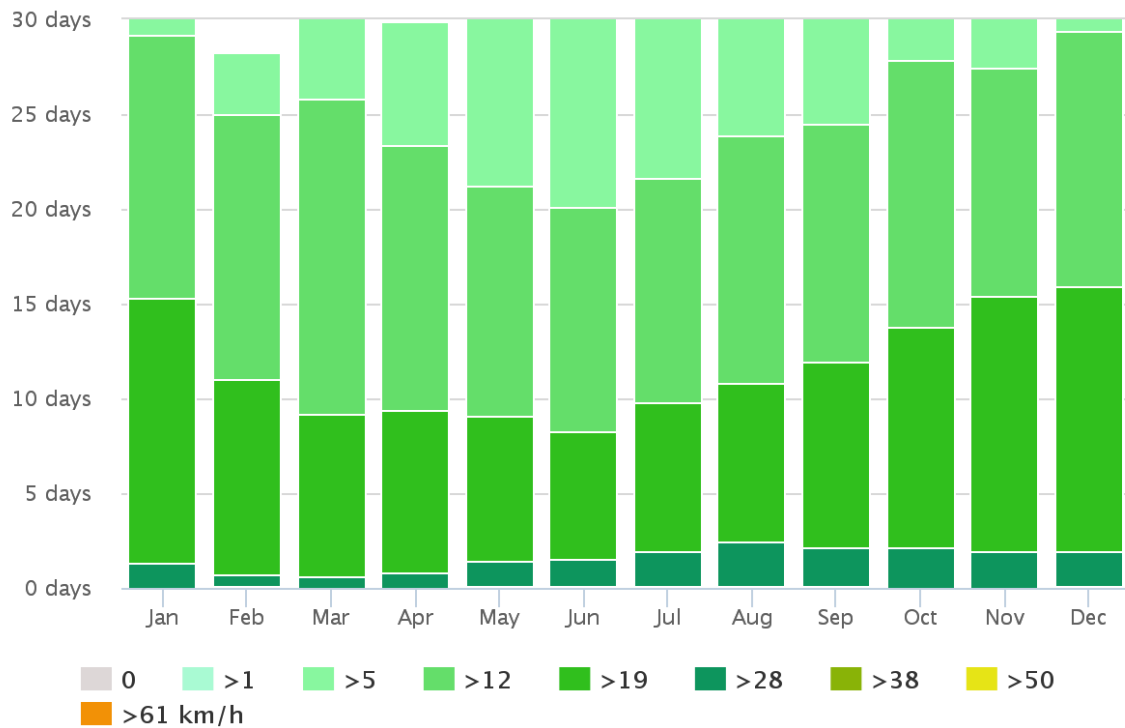

Figure 6-7: Average Wind Speeds for Aggeneys

The wind rose for Aggeneys shows how many hours per year the wind blows from the indicated direction (**Figure 6-8**). The dominate wind direction for Aggeneys is south to south-southeast.

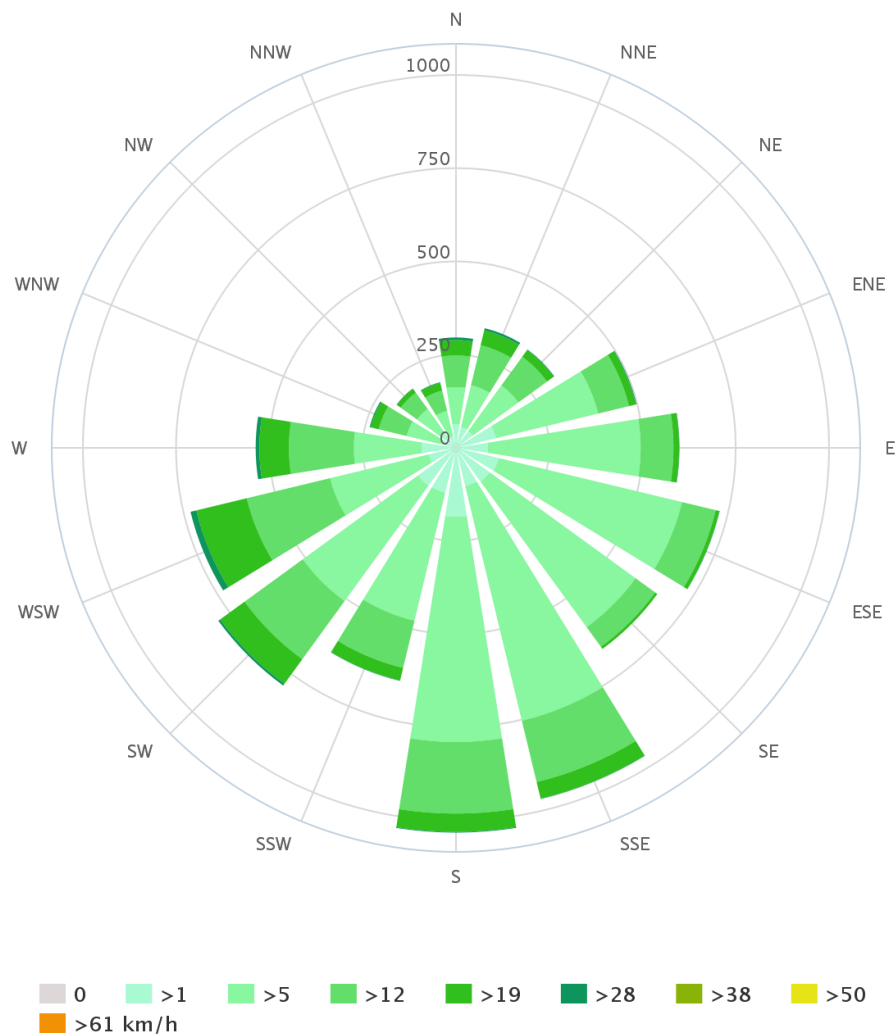

Figure 6-8: Wind Rose for Aggeneys

6.4 SOILS AND LAND CAPABILITY

The soil and land capability specialist study was undertaken by WSP | Parsons Brinckerhoff and is included in **Appendix G**.

SOIL

Based on the land type maps of South Africa (AGIS, 2007) the soils in the area are identified mostly as “Red-yellow apedal, freely drained soils, red, high base status, < 300 mm deep” with minor “Miscellaneous land classes, very rocky with little or no soils” on the inselbergs (small hills) located on the northern boundary of the farm property (**Figure 6-10**). Samples were retrieved from 9 locations in the study area, to describe the soil characteristics of the area (**Figure 6-11**). The location of the soil sampling was determined by the soil land type map as well as on-site observation for changes in the topography and land feature (e.g. wetland) which might induce a change in the soil type. At each location, the soil depth and diagnostics horizons were identified, and a sample was collected for chemical and physical analyses in a soil laboratory. For practical reasons, soil

samples that were collected in a similar setting and had the same soil family, were mixed, to provide representative samples for the area (i.e. SS1 + SS2 + SS3; SS4 + SS5 + SS6; SS7 + SS8 + SS9). The representative soil samples were sent for analyse to the SGS soil laboratory situated in Somerset West in the Western Cape, to determine the pH, electrical conductivity, exchangeable sodium and texture.

All the soil samples were identified as Namib soil form (**Figure 6-9**). The characteristics of the soil samples and profiles are described in **Table 6-1**. The erodibility of the soil is carried out by two modes of transport *viz.* wind and water. Based upon the Department of Agriculture, Forestry and Fisheries GIS data (AGIS, 2007) the soil within the farm property has a high susceptibility to wind erosion, and a low to moderate water erosion hazard. This is evident, given the following characteristics of the area:

- Fine sand texture;
- Single grained structure;
- Clay content ranging between 2 and 5%;
- Dominant flat topography with large open spaces of shrub-like vegetation cover; and
- Infrequent occurrence of sheet flow (with no evidence of gully erosion).



Figure 6-9: Red Apedal Namib Soil Form

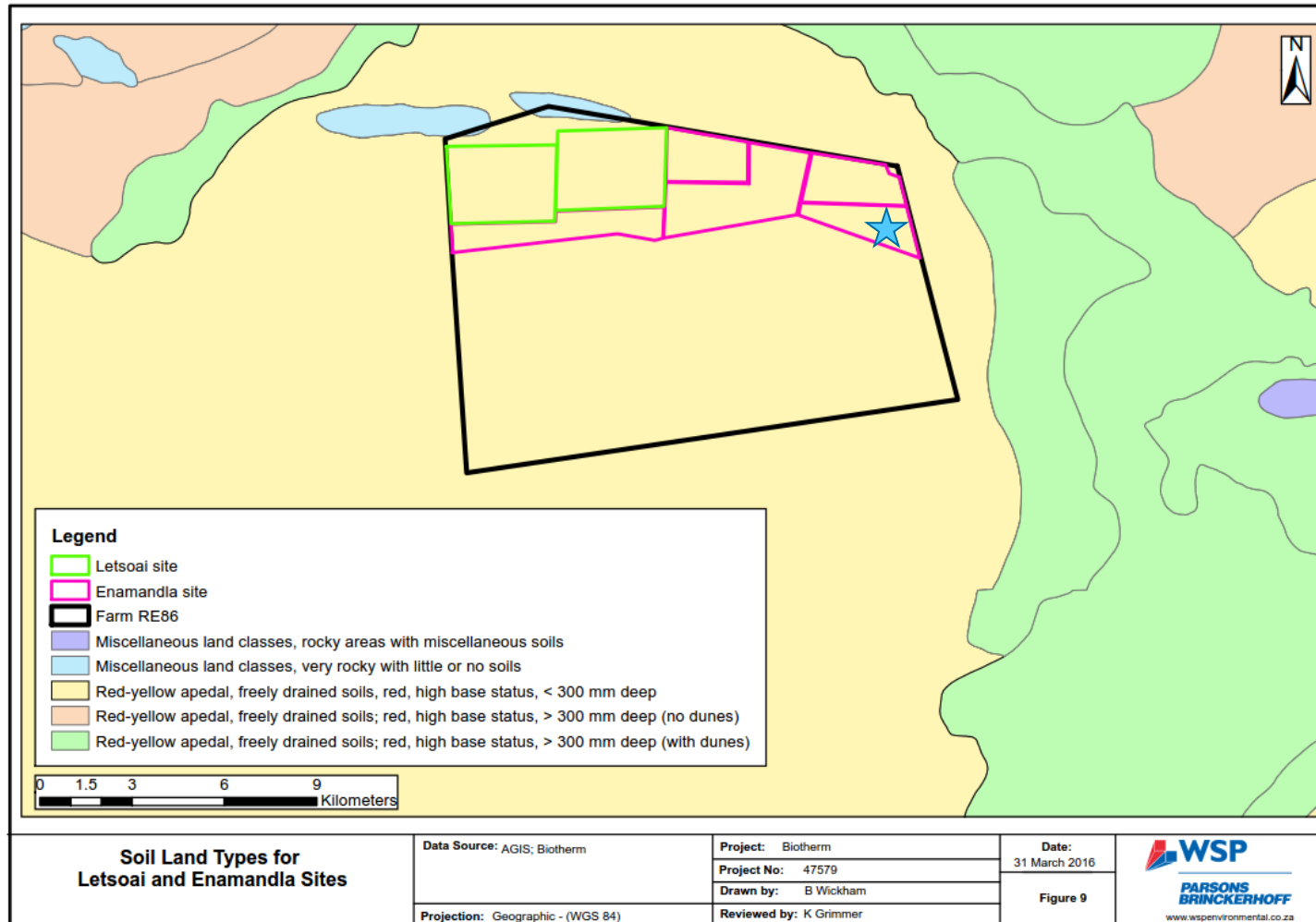

Figure 6-10: Soil land Types for Enamandla PV 5 (Blue Star)

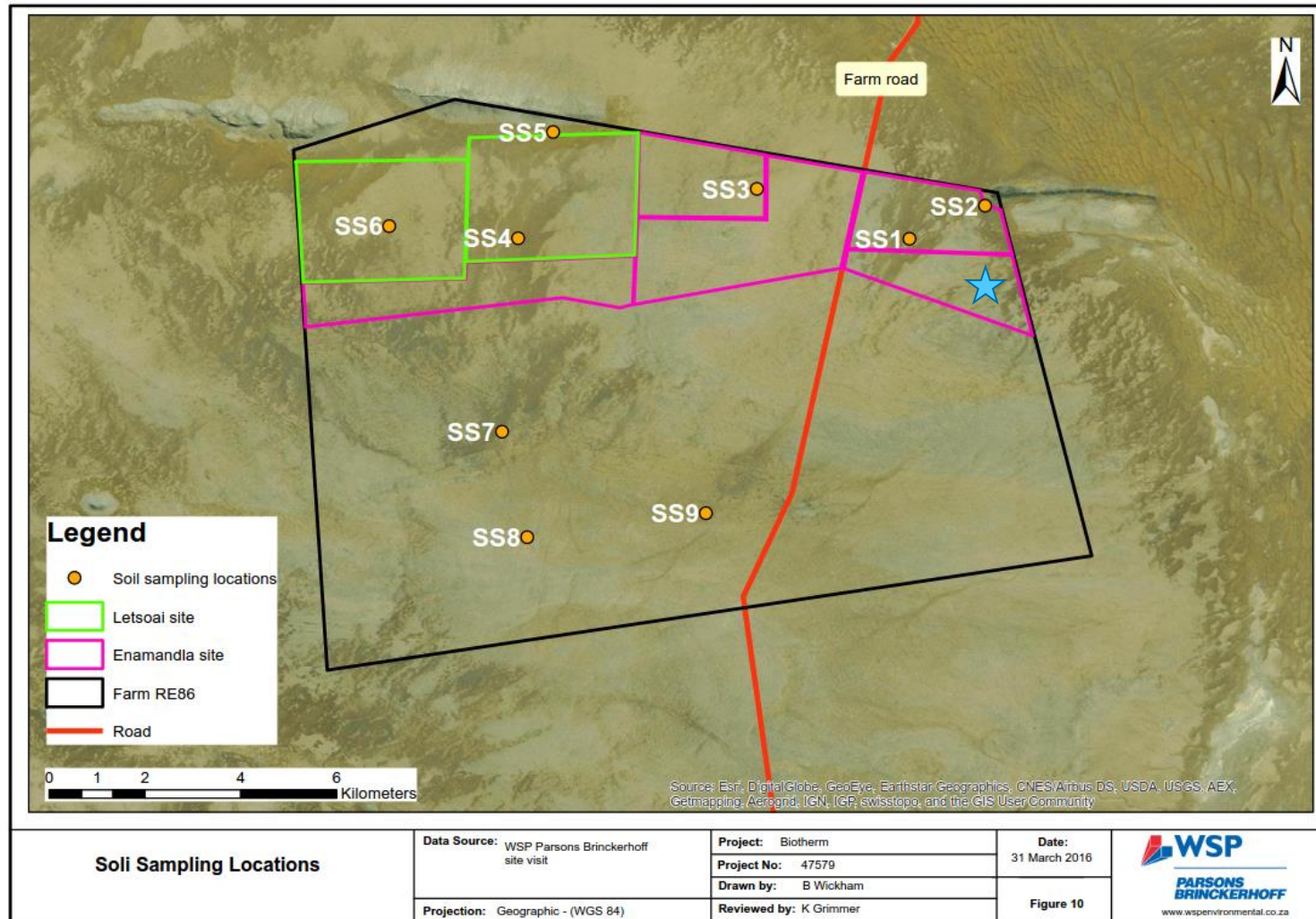

Figure 6-11 Soil Sampling Locations within Farm RE 86 (Enamandla PV 5 indicated with Blue Star)

Table 6-1: Summary of Soil Sample Characteristics

CHARACTERISTIC	SS1	SS2	SS3	SS4	SS5	SS6	SS7	SS8	SS9
Soil Form	Namib	Namib	Namib	Namib	Namib	Namib	Namib	Namib	Namib
Profile Depth	0.16	0.95	0.23	1.58	1.13	0.33	0.31	0.34	0.22
Dry Colour*, mottling and gleying	Pale orange	Pale orange	Orange	Orange	Orange	Pale orange	Orange	Orange	Orange
	Hue 5 YR	Hue 5 YR	Hue 2.5 YR	Hue 2.5 YR	Hue 2.5 YR	Hue 5 YR	Hue 5 YR	Hue 7.5 YR	Hue 7.5 YR
	Value 8	Value 8	Value 8	Value 8	Value 8	Value 8	Value 7	Value 7	Value 7
	Chroma 4	Chroma 4	Chroma 8	Chroma 8	Chroma 8	Chroma 4	Chroma 8	Chroma 6	Chroma 6
Subjective moisture	Dry	Dry	Dry	Dry	Dry	Dry	Dry	Dry	Dry
Effective rooting depth (m) Grasses	0.05	0.05	0.05	0.05	0.05	0.05	0.05	0.05	0.05
Effective rooting depth (m) Shrubs	0.2	0.2	0.2	0.2	0.2	0.2	0.2	0.2	0.2
Soil structure	Single grained	Single grained	Single grained	Single grained	Single grained	Single grained	Single grained	Single grained	Single grained
Presence of rocks, pedocretes, calcareousness	No	No	No	No	No	No	No	No	No
pH	6.7	6.7	6.7	7.1	7.1	7.1	7.4	7.4	7.4
Electrical conductivity (mS/m)	18.4	18.4	18.4	20.1	20.1	20.1	19.9	19.9	19.9
Exchangeable sodium (%)	1.4	1.4	1.4	2.2	2.2	2.2	1.1	1.1	1.1
Sand (S) Silt (Si) & Clay (C) (%)	96, 2, 2	96, 2, 2	96, 2, 2	96, 2, 2	96, 2, 2	96, 2, 2	96, 2, 2	96, 2, 2	96, 2, 2
Texture**	Fine Sand	Fine Sand	Fine Sand	Fine Sand	Fine Sand	Fine Sand	Fine Sand	Fine Sand	Fine Sand
Estimate permeability (m/d)***	1.6 – 6.0	1.6 – 6.0	1.6 – 6.0	1.6 – 6.0	1.6 – 6.0	1.6 – 6.0	1.6 – 6.0	1.6 – 6.0	1.6 – 6.0
Erodibility K factor #	52	52	52	52	52	52	52	52	52

Sources: * Colour based on the revised Standard Soil Colour Chart (Fujihara Industry Co.,2001) ;

** Texture based upon the United States Department of Agriculture (USDA) Soil texture triangle and grain size

*** Estimate Permeability based upon soil structure and texture (van der Molen, Beltran, & Ochs, 2007)

Estimated from the soil erodibility nomograph of Wischmeier, Johnson and Cross (1971)

NATURAL LAND COVER AND LAND USE

The Department of Agriculture, Forestry and Fisheries (DAFF) defines the land use within the farm property, as predominantly Shrubland and Low Fynbos, with smaller pockets of unimproved (natural) Grassland, and minor areas of Woodlands (DAFF, 2012) (**Figure 6-13**). From **Figure 6-13**, there were two wetlands located approximately 3 km south of the study area, near the western and lower-middle boundary of the farm property. Upon the site visit, the wetland near the lower-middle boundary of the farm property was identified as an old broken earth-wall dam, and is thus not a wetland. The second wetland near the east of the farm boundary could not be located during the study area visit and thus it could not be verified or delineated. Given the low rainfall, high evaporation climate, sandy soil with a high transmissivity of water, and the time of year of the study area visit (i.e. dry season) made it unlikely to find the wetland, which may actually not be a wetland, but rather a temporary, small puddle of water, that forms on the surface after a significantly high rainfall event, during the wetter time of the year. As such there was no wetland identified in the study area.

Observations during the study area walkover were that the majority of the vegetation was shrub-like arid grassland, which was primarily used for sheep grazing. Cattle grazing activities were also present in the area. In addition, there were herds of Springbok grazing on the land within Farm RE86 property. The boreholes, driven by windmills, provide water to small reservoirs and water tanks throughout the farm for the sheep.

In the greater area there is extensive mining and associated infrastructure. Electricity is supplied to the Black Mountain Mine (**Figure 6-12**) by the Electricity Supply Commission network at the Hydra sub-station at De Aar, via two overhead powerlines (RHDHV, 2013). The water supply to Aggeneys and the mine is currently supplied from the Orange River via the Pelladrift pump station and a 50km pipeline (DWS, 2016).

It should also be noted that the area partially falls within the Springbok Wind REDZ and Northern EGI Corridor. These areas are targeted for renewable energy and electricity grid infrastructure development and so this future intended land use will alter the visual landscape. Although construction has not yet commenced, a concentration of wind energy farms, in close proximity to the study area, will cumulatively significantly alter the vertical landscape and character of the area.



Figure 6-12: Black Mountain Tailings Dam

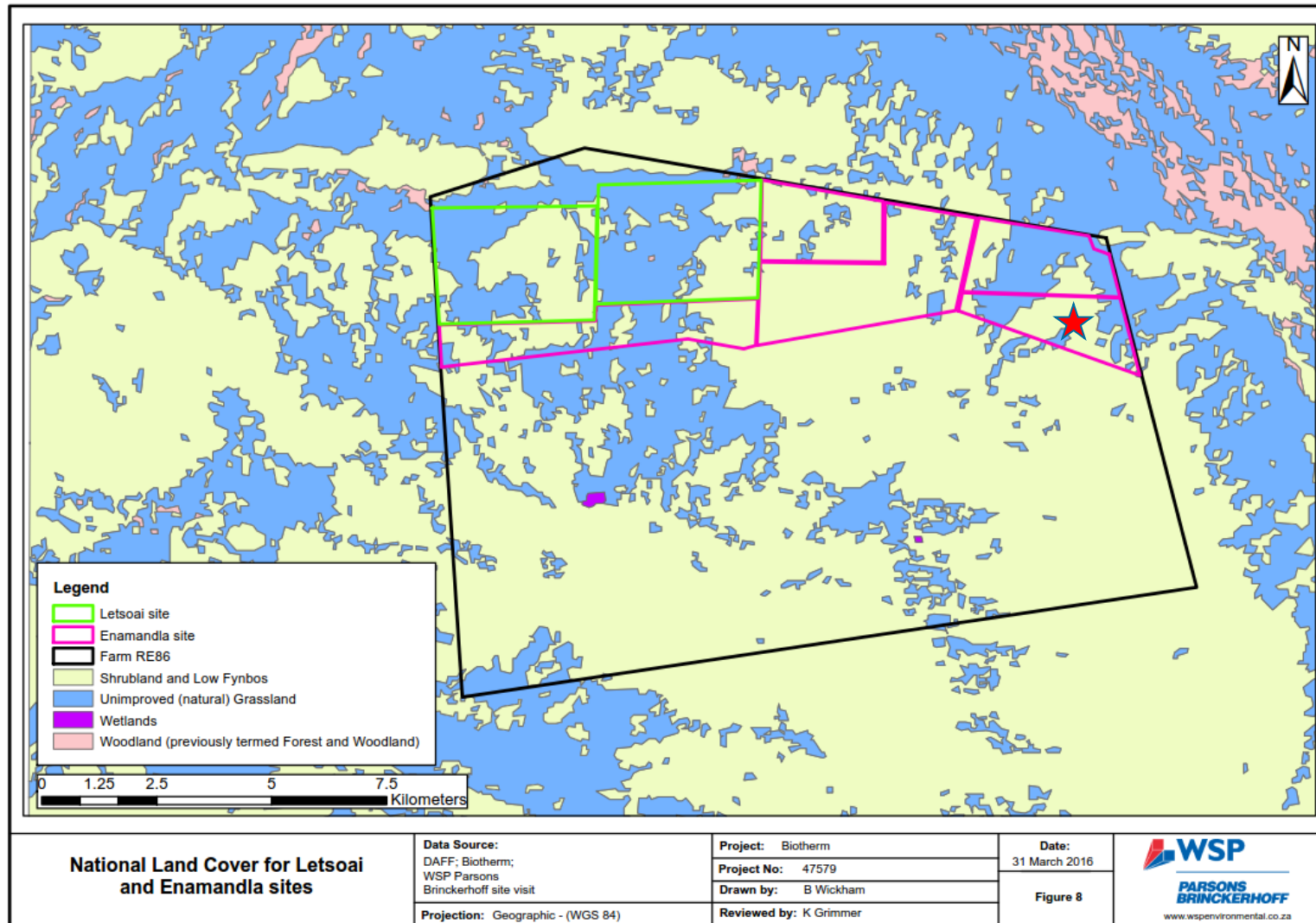

Figure 6-13: National Land Cover for the Study Area (Enamandla PV 5 indicated with a red star)

6.5 NATURAL VEGETATION AND ANIMAL LIFE

The biodiversity specialist study was undertaken by Simon Todd Consulting and is included in **Appendix H**.

BROAD-SCALE VEGETATION PATTERNS

According to the national vegetation map (Mucina & Rutherford 2006), (**Figure 6-14**) the study area is restricted to the Bushmanland Arid Grassland vegetation type.

Bushmanland Arid Grassland vegetation type is an extensive vegetation type and is the second most extensive vegetation type in South Africa and occupies an area of 45 478 km². It extends from the study area around Aggeneys in the east to Prieska in the west. It is associated largely with red-yellow apedal (without structure), freely drained soils, with a high base status and is mostly less than 300mm deep. Due to the arid nature of the unit, which receives between 70 and 200 mm annual rainfall, it has not been significantly impacted by intensive agriculture and more than 99% of the original extent of the vegetation type is still intact. Mucina & Rutherford (2006) lists 6 endemic species for the vegetation type which is a relatively low number is given the extensive nature of the vegetation type.

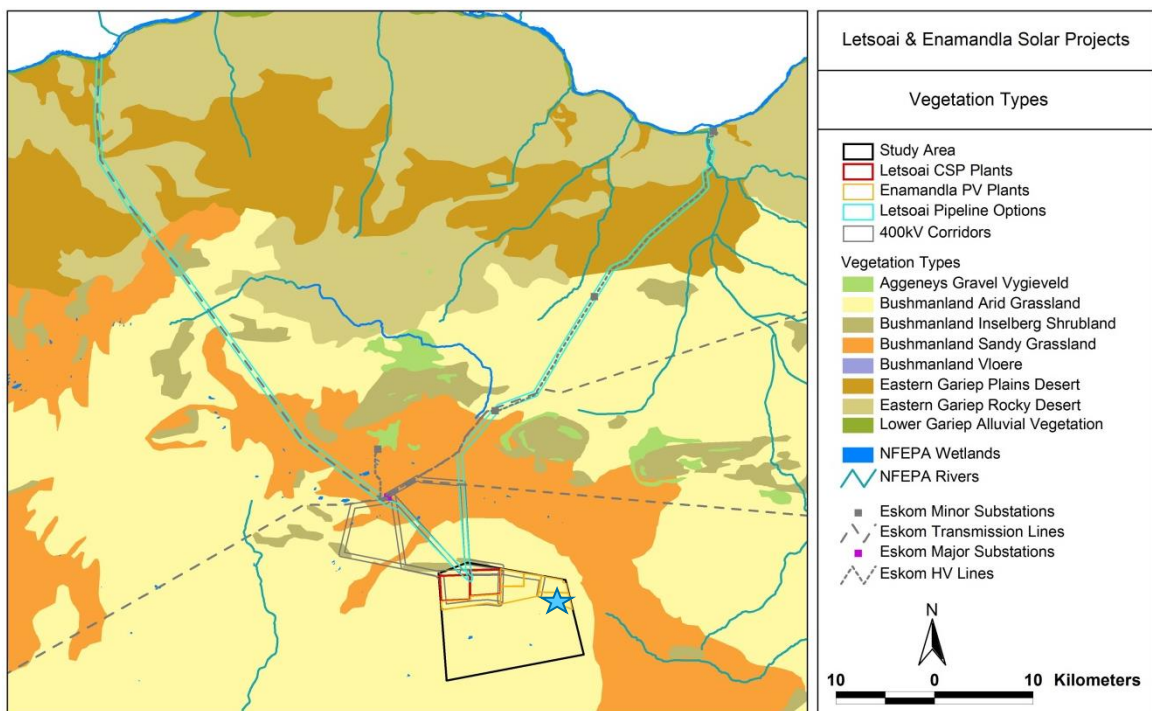

Figure 6-14: Broad-scale overview of the vegetation in and around Enamandla PV 5 (blue star)

LISTED AND PROTECTED PLANT SPECIES

According to the SANBI SIBIS database, 309 indigenous plant species have been recorded from the quarter degree squares 2918 AB, BA, AD and BC. This includes 11 species of conservation concern as listed below in **Table 6-2**. Only *Hoodia gordonii* can be confirmed present in the study area; it is not likely that any of the other listed species are present. There are some *Boscia albitrunca* trees present on the hills of the area, which is a nationally protected species but would not be affected by the project. There are also some species protected under the Northern Cape Nature Conservation Act of 2009, which are present in the area including *Boscia foetida* subsp. *foetida* and

all species within the *Mesembryanthemaceae*, *Euphorbiaceae*, *Oxalidaceae*, *Iridaceae* and all species within the genera *Nemesia* and *Jamesbrittenia*.

Table 6-2: Listed Species known from the broad area around the site

FAMILY	SPECIES	STATUS
CRASSULACEAE	<i>Crassula decumbens</i> var. <i>brachyphylla</i>	NT
MESEMBRYANTHEMACEAE	<i>Conophytum limpidum</i>	NT
CRASSULACEAE	<i>Crassula exilis</i> subsp. <i>exilis</i>	Rare
FABACEAE	<i>Crotalaria pearsonii</i>	Rare
HYACINTHACEAE	<i>Lachenalia polypodantha</i>	Rare
MESEMBRYANTHEMACEAE	<i>Conophytum tantillum</i> subsp. <i>eenkokerense</i>	Rare
OXALIDACEAE	<i>Oxalis inconspicua</i>	Rare
ASTERACEAE	<i>Othonna euphorbioides</i>	Thr*
HYACINTHACEAE	<i>Daubinya namaquensis</i>	Thr*
MESEMBRYANTHEMACEAE	<i>Cheiridopsis rostrata</i>	VU
APOCYNACEAE	<i>Hoodia gordonii</i>	DDD
AMARYLLIDACEAE	<i>Brunsvigia namaquana</i>	DDT
ASTERACEAE	<i>Senecio glutinarius</i>	DDT
MESEMBRYANTHEMACEAE	<i>Drosanthemum breve</i>	DDT
AMARYLLIDACEAE	<i>Boophone disticha</i>	Declining

ALIEN PLANT SPECIES ABUNDANCE

Alien species abundance at the site is generally low, which can be ascribed to the very arid nature of the area. However, with disturbance and increased runoff from the project during construction and operation, alien species may become more prevalent. The most conspicuous alien on the site is *Prosopis glandulosa* which has been planted to provide shade for livestock, but it has not spread and is not currently invading the site. The only other alien observed was *Salsola kali* which was present near to some of the watering points. It was however relatively dry at the time of sampling and additional species are likely to appear after rains. Overall, the site can currently be considered largely free of alien plant species and has not been significantly impacted by aliens in any way.

CRITICAL BIODIVERSITY AREAS AND BROAD-SCALE PROCESSES

The site falls within the planning domain of the Namakwa Biodiversity Sector Plan (Desmet & Marsh 2008) (**Figure 6-15**). This biodiversity assessment identifies Critical Biodiversity Areas (CBAs) which represent biodiversity priority areas which should be maintained in a natural to near natural state. The CBA maps indicate the most efficient selection and classification of land portions requiring safeguarding in order to meet national biodiversity objectives. When incorporated into municipal SDFs and bioregional plans, such fine-scale plans are recognized under NEMA and the various activities listed under the act. The proposed site does not occur within a CBA area.

The site falls within a NPAES focus area, meaning that the area has been identified as a large currently intact area which has high biodiversity potential and is not currently well represented within

the existing protected area network. The major concern in this regard is the availability of other similar habitat in the area. While the broader landscape contains several features and vegetation types of concern, these are outside of the study area; the typical Bushmanland grassy plains habitat within the site is very widely available in the area and the development of the site would not be likely to affect the availability of this habitat in the broader area. Therefore it is not likely that the development of the site would significantly affect the focus area or the ability to meet conservation targets for the affected habitat types.

Of greater concern, would be the potential cumulative impacts of renewable energy development in the area as depicted by **Figure 6-16** showing all the renewable energy applications registered with the DEA as at April 2016. There are a number of developments in the area and in the longer term, an east-west corridor of development is developing along the N14 from Springbok to Pofadder and threatens to disrupt landscape connectivity in a north-south direction to and from the Orange River. However, the DEA map does not indicate the actual footprint of the facilities which are in most cases much smaller than the cadastral units indicated. Therefore, there are still large undeveloped gaps between the different projects. Furthermore, the map does not indicate preferred bidders, and so not all of the applications would actually get built.

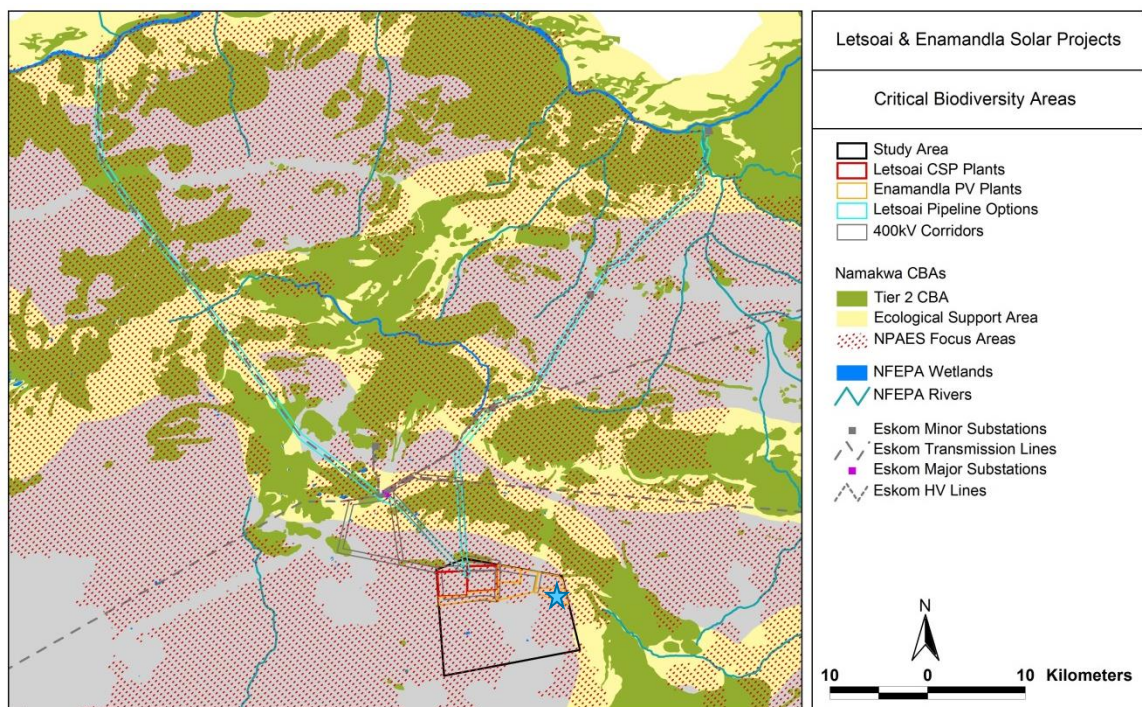

Figure 6-15: Critical Biodiversity Areas map of the area around Enamandla PV 5 (Blue Star)

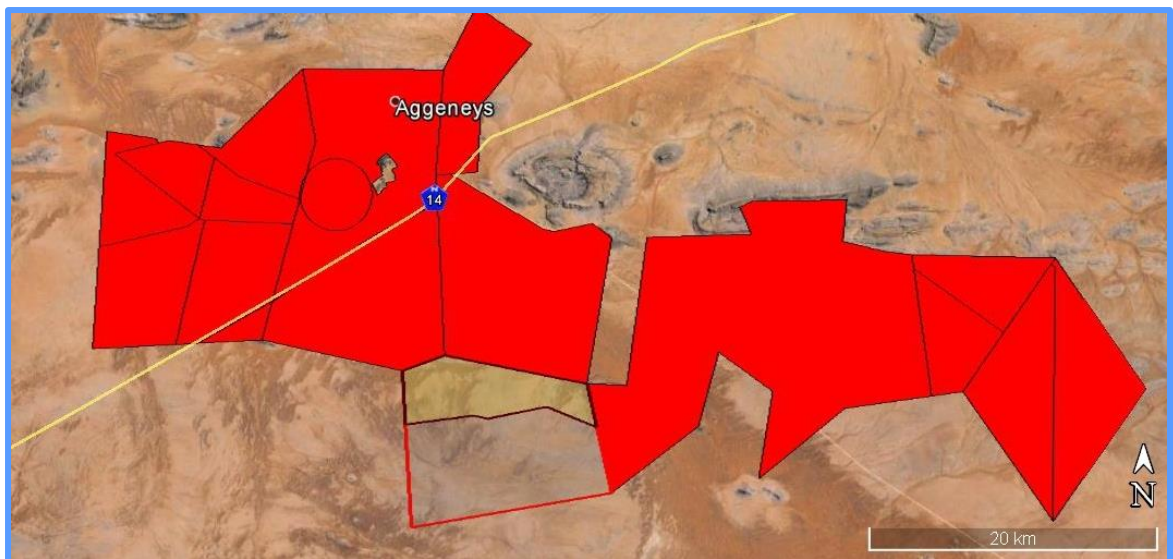

Figure 6-16: Map of DEA registered renewable energy applications as of April 2016.

FAUNAL COMMUNITIES

MAMMALS

The study area falls within the distribution range of 46 terrestrial mammals, although only around 20 are recorded in the area on a regular basis based on records from the MammalMap database³. Species that can be confirmed present in the area based on previous site visit to the area include Black-backed Jackal, African Wildcat, Cape Fox, Rock Hyrax, South African Ground Squirrel, Steenbok, Springbok, Gemsbok, Cape Porcupine, Yellow Mongoose, Cape Hare, Aardvark and Round-eared Elephant Shrew.

Species associated with the rocky outcrops of the area include Rock Hyrax *Procavia capensis*, Klipspringer *Oreotragus oreotragus*, Pygmy Rock Mouse *Petromyscus collinus*, Namaqua Rock Mouse *Aethomys namaquensis* and Western Rock Elephant Shrew *Elephantulus rupestris*. The open plains which characterise the development areas are likely to be dominated by species associated with open hard or sandy ground such as various gerbils including the Hairy-footed Gerbil *Gerbillurus pæba*. There were also many burrows of Ground Squirrels and Yellow Mongoose in the study area; these appear to be the most commonly occurring fauna. There are no areas of particular significance for mammals in the study area as the habitat is repetitive and broadly homogenous.

Two listed species may occur in the area, the Black-footed cat *Felis nigripes* (Vulnerable) and Leopard *Panthera pardus* (Near Threatened). Given the extremely low cover in the study area it is not likely that Leopard are present in the study area. The habitat is however suitable for the Black-footed Cat which favours a mix of open and more densely vegetated areas. However this species is widely distributed across the arid and semi-arid areas of South Africa, and the development would not amount to a significant amount of habitat loss for this species, although some cumulative impact in the area is a developing threat.

³ The aim of MammalMAP is to update the distribution records of all African mammal species. Through collaborations with professional scientists, conservation organisations, wildlife authorities and citizen scientists across Africa (www.mammalmap.adu.org.za)

The major impact to mammals associated with the development of the study area, would be habitat loss for resident species and potentially some disruption of the broad-scale connectivity of the landscape.

REPTILES

Although reptile diversity in the broader area is high with as many as 60 species known from the area, only a fraction of these are likely to be present within the study area. A large proportion of the reptiles of the area consist of species associated with the inselbergs and rocky hills along the Orange River and would not occur on the open plains characteristic of the study area. More typical plains species are likely to dominate the study area and is likely to include Verroxx's Tent Tortoise *Psammobates tentorius verroxii*, Namaqua Sand Lizard *Pedioplanis namaquensis*, Spotted Desert Lizard *Meroles suborbitalis*, Southern Rock Agama *Agama atra* and Plain Sand Lizard *Pedioplanis inornata*.

As with mammals, there are not likely to be any highly significant impacts on reptiles besides some habitat loss in the project footprint. Some species such as geckos will probably increase within the development on account of the increased vertical structure and shelter provided by the panels and their supports.

AMPHIBIANS

Only eight frog species are known from the area around the study area; and even this is a gross overestimate of the number of amphibian species likely to be present within the study area. There are few freshwater features present and only species able to live independently of water will be present in the study area. As such the only species likely to be present within the study area would be the Karoo Toad *Vandijkophrynus garipeensis*. Given the very low likely abundance of amphibians in the study area, impacts on amphibians are likely to be local in extent and of low significance.

6.6 AVIFAUNA

The avifauna specialist study was undertaken by Chris van Rooyen Consulting and is included in **Appendix I**.

The habitat in the study area is highly homogenous and consists of extensive sandy and gravel plains. The study area lies just south of the Koa River Valley, a fossil river of red dunes which is considered to be the core habitat for the globally threatened Red Lark *Calendulauda burra*. To the north of the study area, isolated mountains (Namiesberge, Achab se Berge, Ghaamsberg) are present. The vegetation in the study area itself consists mostly of grasses and shrubs scattered between bare patches of red sand and gravel. The main vegetation type is Bushmanland Arid Grassland, which is dominated by white grasses (*Stipagrostis* species) giving this vegetation the character of semi-desert "steppe".

South African Bird Atlas Project 1 (SABAP1) recognises six primary vegetation divisions within South Africa, namely (1) Fynbos (2) Succulent Karoo (3) Nama Karoo (4) Grassland (5) Savanna and (6) Forest (Harrison et al 1997). The criteria used by the authors to amalgamate botanically defined vegetation units, or to keep them separate were (1) the existence of clear differences in vegetation structure, likely to be relevant to birds, and (2) the results of published community studies on bird/vegetation associations. It is important to note that no new vegetation unit boundaries were created, with use being made only of previously published data. Using this classification system, the natural vegetation in the study area can be classified as Nama Karoo.

Peak rainfall in the study area occurs mainly in summer and averages around 71mm per year, which makes it an extremely arid area. Because rainfall in the Nama Karoo falls mainly in summer, while peak rainfall in the Succulent Karoo occurs mainly in winter, it provides opportunities for birds

to migrate between the Succulent and Nama Karoo, to exploit the enhanced conditions associated with rainfall. Many typical karroid species are nomads, able to use resources that are patchy in time and space, e.g. Sclater's Lark (Barnes 1998).

The study area is located close to the Haramoep and Black Mountain (SA035) Important Bird Area (IBA). Situated near Aggeneys, this IBA is characterised by an arid landscape of extensive sandy and gravel plains with sparse vegetation scattered between bare sand patches. Inselbergs form islands of rocky habitat in a sea of red sand. Large sand dunes fill the fossil course of the Koa River. The gravel plains are covered by sparse dwarf shrubs and short bushman grasses and they hide dwarf succulents. The dry riverbeds support taller woody vegetation, including *Boscia* species. Although much of the land area remains natural, large areas are overgrazed and degraded. Approximately 90% of the land is natural and utilised for ranching. The rest has been transformed by agriculture, mining activities, homesteads, settlements, erosion, roads and power-line servitudes.

This IBA is one of only a few sites protecting the globally threatened Red Lark *Calendulauda burra*, which inhabits the red sand dunes and sandy plains with a mixed grassy dwarf shrub cover; and the near-threatened Sclater's Lark *Spizocorys sclateri*, on the barren stony plains. It also holds 16 of the 23 Namib-Karoo biome-restricted assemblage species as well as a host of other arid-zone birds. Ludwig's Bustard *Neotis ludwigii* and Kori Bustard *Ardeotis kori* are regularly seen. Martial Eagle *Polemaetus bellicosus*, Secretarybird *Sagittarius serpentarius*, Verreaux's Eagle *Aquila verreauxii*, Booted Eagle *Hieraaetus pennatus*, Cape Eagle-Owl *Bubo capensis* and Spotted Eagle-Owl *Bubo africanus* are present.

The following species are classified as trigger species for the IBA, several of which could potentially occur at the study area (highlighted in **bold**):

- Globally threatened birds
 - **Red Lark (*Calendulauda burra*)**;
 - Sclater's Lark (*Spizocorys sclateri*);
 - **Martial Eagle (*Polemaetus bellicosus*)**;
 - Kori Bustard (*Ardeotis kori*);
 - **Ludwig's Bustard (*Neotis ludwigii*)**; and
 - **Secretarybird (*Sagittarius serpentarius*)**.
- Regionally threatened birds
 - **Karoo Korhaan (*Eupodotis vigorsii*)**; and
 - **Verreaux's Eagle (*Aquila verreauxii*)**.
- Restricted-range and biome-restricted birds
 - **Stark's Lark (*Spizocorys starki*)**;
 - **Karoo Long-billed Lark (*Certhilauda subcoronata*)**;
 - **Black-eared Sparrow-lark (*Eremopterix australis*)**;
 - **Tractrac Chat (*Cercomela tractrac*)**;
 - **Sickle-winged Chat (*Cercomela sinuate*)**;
 - **Karoo Chat (*Cercomela schlegelii*)**;
 - Layard's Tit-Babbler (*Sylvia layardi*);
 - **Karoo Eremomela (*Eremomela gregalis*)**;
 - Cinnamon-breasted Warbler (*Euryptila subcinnamomea*);

- Namaqua Warbler (*Phragmacia substriata*);
- **Sociable Weaver (*Philetairus socius*)**;
- **Pale-winged Starling (*Onychognathus nabouroup*)**; and
- **Black-headed Canary (*Serinus alario*)**.

Figure 6-17 shows the study area relative to the Haramoep and Black Mountain (SA035) Important Bird Area.

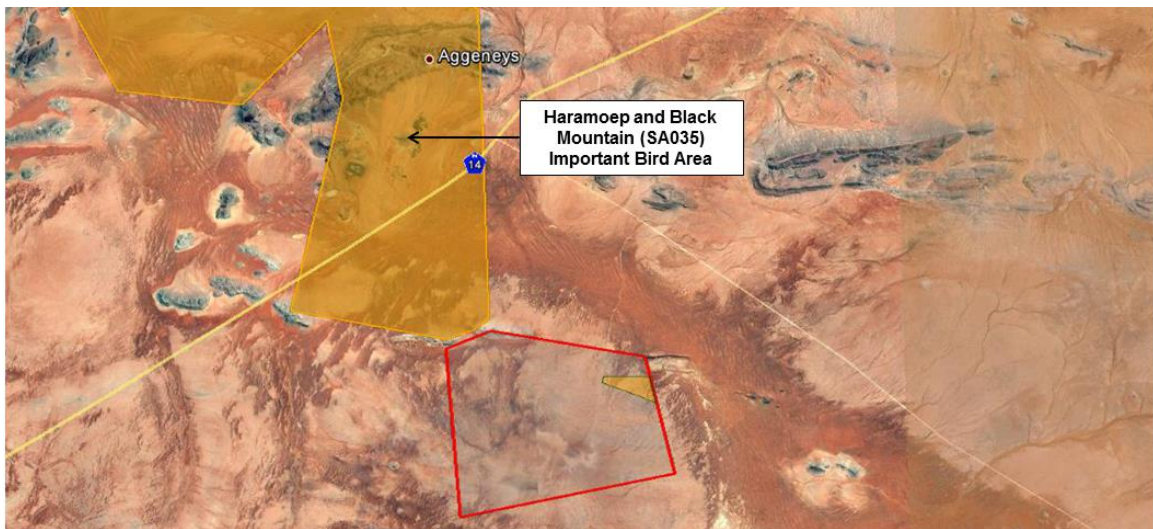

Figure 6-17: The Proposed Study Area (Orange) in relation to the Haramoep and Black Mountain (SA035) Important Bird Area

Whilst the distribution and abundance of the bird species in the study area are mostly associated with natural vegetation, as this comprises virtually all the habitat, it is also necessary to examine a few external modifications to the environment that might have relevance for priority species.

The following anthropogenic avifaunal-relevant habitat modifications were recorded within the study area:

- **Water points:** The land use in the study area is mostly sheep farming, with some game and cattle also present. The entire area is divided into fenced off grazing camps, with a few boreholes with associated water reservoirs and drinking troughs. These troughs and reservoirs are a big draw card for several bird species. Priority species that could regularly visit waterholes are Southern Pale Chanting Goshawk, Red Lark, Sclater's Lark, Martial Eagle, Booted Eagle, Secretarybird, Black-eared Sparrowlark Lanner Falcon and Black-chested Snake-Eagle. Large flocks of Namaqua Sandgrouse descend to water troughs to drink, which in turn draw in raptors.
- **Transmission lines, reticulation lines, telephone lines and fence lines:** The Aggeneys – Aries 400kV transmission line runs to the north of the study area. There are also several high voltage lines west of the N14 which converges into the Aggeneys MTS. The transmission towers are used by raptors for perching and roosting, and potentially also for breeding. An active Martial Eagle nest was recorded on a tower which is approximately 20km away from the study area. The transmission lines, reticulation lines and telephones lines are all used as perches by a number of priority raptors, e.g. Greater Kestrel, Black-chested Snake-eagle, Martial Eagle and Rock Kestrel. Smaller species such as Red Lark and Sclater's Lark also often perch on the fence lines, as do Greater Kestrel and Rock Kestrel. The transmission lines in the study area pose a major risk of collisions to Ludwig's Bustard, Karoo Korhaan and Secretarybird.

A total of 113 species could potentially occur in the study area; of these, 42 are classified as priority species. **Table 6-3** lists the priority species that could potentially occur in the study area, as well as the potential impact on these species.

Table 6-3: Priority Species that could potentially occur in the study area (EN = Endangered, VU = Vulnerable, NT = Near Threatened, LC = Least Concern)

FAMILY NAME	TAXONOMIC NAME	REPORTING RATE	GLOBAL STATUS	REGIONAL STATUS	ENDEMIC - SOUTH AFRICA	ENDEMIC - SOUTHERN AFRICA	PRIORITY SPECIES	RECORDED DURING PRE-CONSTRUCTION MONITORING	DISPLACEMENT DUE TO DISTURBANCE	DISPLACEMENT DUE TO HABITAT TRANSFORMATION	COLLISION WITH PV PANELS	COLLISIONS WITH HELIOSTATS	BURNING THROUGH SOLAR FLUX	COLLISION WITH POWERLINES
Bustard, Ludwig's	<i>Neotis ludwigii</i>	7.41	EN	EN		Near-endemic	x	x	x	x			x	x
Chat, Tractrac	<i>Cercomela tractrac</i>	14.81				Near-endemic	x	x	x	x	x	x		
Harrier, Montagu's	<i>Circus pygargus</i>						x	x		x		x	x	x
Kestrel, Greater	<i>Falco rupicoloides</i>	37.04					x	x	x	x	x	x	x	
Korhaan, Karoo	<i>Eupodotis vigorsii</i>	14.81	LC	NT		Endemic	x	x	x	x				x
Lark, Red	<i>Calendulauda burra</i>	66.67	VU	VU	Endemic	Endemic	x	x	x	x	x	x		
Secretarybird	<i>Sagittarius serpentarius</i>	0	VU	VU			x	x	x	x			x	x
Snake-eagle, Black-chested	<i>Circaetus pectoralis</i>	7.41					x	x	x	x			x	
Sparrowlark, Black-eared	<i>Eremopterix australis</i>	11.11			Near endemic	Endemic	x	x	x	x	x	x		
Buzzard, Jackal	<i>Buteo rufofuscus</i>	3.7			Near endemic	Endemic	x		x	x			x	
Canary, Black-headed	<i>Serinus alario</i>	11.11			Near endemic	Endemic	x		x	x	x	x		
Chat, Karoo	<i>Cercomela schlegelii</i>	44.44				Near-endemic	x		x	x	x	x		

FAMILY NAME	TAXONOMIC NAME	REPORTING RATE	GLOBAL STATUS	REGIONAL STATUS	ENDEMIC - SOUTH AFRICA	ENDEMIC - SOUTHERN AFRICA	PRIORITY SPECIES	RECORDED DURING PRE-CONSTRUCTION MONITORING	DISPLACEMENT DUE TO DISTURBANCE	DISPLACEMENT DUE TO HABITAT TRANSFORMATION	COLLISION WITH PV PANELS	COLLISIONS WITH HELIOSTATS	BURNING THROUGH SOLAR FLUX	COLLISION WITH POWERLINES
Chat, Sickle-winged	<i>Cercomela sinuata</i>	7.41			Near endemic	Endemic	x		x	x	x	x		
Coot, Red-knobbed	<i>Fulica cristata</i>	11.11					x				x	x		x
Duck, Maccoa	<i>Oxyura maccoa</i>	7.41	NT	NT			x				x	x		x
Duck, Yellow-billed	<i>Anas undulata</i>	3.7					x				x	x		x
Eagle, Booted	<i>Hieraaetus pennatus</i>	3.7					x		x	x	x	x	x	
Eagle, Martial	<i>Polemaetus bellicosus</i>	3.7	VU	EN			x		x	x			x	
Eagle, Verreaux's	<i>Aquila verreauxii</i>	7.41	LC	VU			x		x	x			x	
Eremomela, Karoo	<i>Eremomela gregalis</i>	7.41			Near endemic	Endemic	x		x	x	x	x		
Falcon, Lanner	<i>Falco biarmicus</i>	3.7	LC	VU			x		x	x	x	x	x	
Falcon, Pygmy	<i>Polihierax semitorquatus</i>	7.41					x			x	x	x		
Flamingo, Greater	<i>Phoenicopterus roseus</i>		LC	NT			x				x	x	x	x
Flamingo, Lesser	<i>Phoenicopterus minor</i>		LC	NT			x				x	x	x	x
Flycatcher, Fairy	<i>Stenostira scita</i>	3.7			Near endemic	Endemic	x		x	x	x	x		
Goose, Egyptian	<i>Alopochen aegyptiaca</i>	11.11					x				x	x	x	x

FAMILY NAME	TAXONOMIC NAME	REPORTING RATE	GLOBAL STATUS	REGIONAL STATUS	ENDEMIC - SOUTH AFRICA	ENDEMIC - SOUTHERN AFRICA	PRIORITY SPECIES	RECORDED DURING PRE-CONSTRUCTION MONITORING	DISPLACEMENT DUE TO DISTURBANCE	DISPLACEMENT DUE TO HABITAT TRANSFORMATION	COLLISION WITH PV PANELS	COLLISIONS WITH HELIOSTATS	BURNING THROUGH SOLAR FLUX	COLLISION WITH POWERLINES
Grebe, Little	<i>Tachybaptus ruficollis</i>	11.11					x				x	x		x
Kestrel, Rock	<i>Falco rupicolus</i>	40.74					x	x	x	x	x	x	x	
Kite, Black-shouldered	<i>Elanus caeruleus</i>	3.7					x		x	x	x	x	x	
Lark, Cape Clapper	<i>Mirafra apiata</i>	11.11			Near endemic	Endemic	x		x	x	x	x		
Lark, Karoo Long-billed	<i>Certhilauda subcoronata</i>	48.15				Endemic	x		x	x	x	x		
Lark, Stark's	<i>Spizocorys starki</i>	14.81				Near-endemic	x		x	x	x	x		
Ruff	<i>Philomachus pugnax</i>	3.7					x				x	x		
Sandpiper, Common	<i>Actitis hypoleucos</i>	3.7					x				x	x		
Sandpiper, Wood	<i>Tringa glareola</i>	3.7					x				x	x		
Shelduck, South African	<i>Tadorna cana</i>	14.81				Endemic	x				x	x		x
Shoveler, Cape	<i>Anas smithii</i>	7.41				Near-endemic	x				x	x		x
Starling, Pale-winged	<i>Onychognathus nabouroup</i>	77.78				Near-endemic	x		x		x	x		
Stilt, Black-winged	<i>Himantopus himantopus</i>	7.41					x				x	x		
Stint, Little	<i>Calidris minuta</i>	3.7					x				x	x		

FAMILY NAME	TAXONOMIC NAME	REPORTING RATE	GLOBAL STATUS	REGIONAL STATUS	ENDEMIC - SOUTH AFRICA	ENDEMIC - SOUTHERN AFRICA	PRIORITY SPECIES	RECORDED DURING PRE-CONSTRUCTION MONITORING	DISPLACEMENT DUE TO DISTURBANCE	DISPLACEMENT DUE TO HABITAT TRANSFORMATION	COLLISION WITH PV PANELS	COLLISIONS WITH HELIOSTATS	BURNING THROUGH SOLAR FLUX	COLLISION WITH POWERLINES
Teal, Cape	<i>Anas capensis</i>	11.11					x				x	x		
Weaver, Sociable	<i>Philetairus socius</i>	77.78				Endemic	x		x	x	x	x		

6.7 SURFACE WATER

The Water Resources 2012 (WR2012) Study (Water Research Commission/Department of Water and Sanitation i.e. WRC/DWS, 2012) was used to obtain the climatic and hydrological data for the area. This study modelled South Africa (including Lesotho and Swaziland) on a quaternary basis. Catchments were delineated into primary (e.g. D), secondary (e.g. D8), tertiary (e.g. D82) and quaternary (e.g. D82B), with quaternary catchments considered to be the generally accepted level of analysis or modelling.

South Africa is divided into 19 Water Management Areas (WMAs); the study area situated in the Lower Orange WMA. This WMA makes up the downstream portion of the Orange River Basin, which starts in the Lesotho Highlands headwaters of the Senqu River. The Upper Orange WMA, as well as the Upper, Middle and Lower Vaal WMA's all contribute to the Orange River Basin as a whole. As one moves westward along the Orange River, from the headwaters in Lesotho to the Atlantic Ocean, the drier the climate becomes (lower precipitation and higher evaporation).

Within the Lower Orange WMA, the study area lies within tertiary D82, and overlays parts of the D82B and D82C quaternary catchments (**Figure 6-18**).

The study area is situated approximately 55km south of the Orange River, the longest river in South Africa with the largest catchment area of almost 1 000 000km². The headwater of the Orange River is the Senqu River in Lesotho, flowing west towards the Atlantic Ocean, where it exits at Alexander Bay.

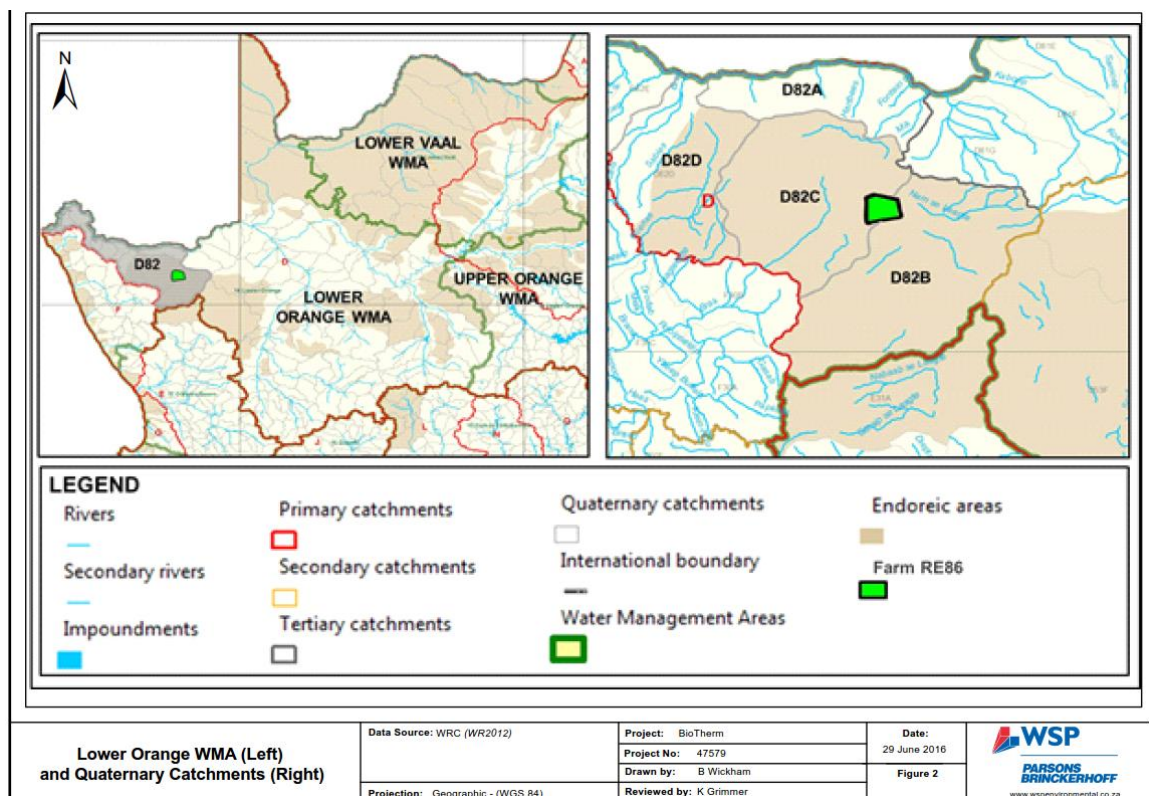

Figure 6-18: Lower Orange WMA (left) and Quaternary Catchments (right)

WATER USERS

The DWS WARMS Database was used to identify the water use within the D82 tertiary. Water use within D82B and D82C is associated with livestock watering, water supply services (towns), and mining. The detailed volumes of water use used for irrigation are shown in **Table 6-4**. All irrigation in the tertiary is supplied via water schemes connected to the Orange River, excluding two areas which are supplied directly from a river/stream. The DWS WARMS database does not indicate any irrigation in D82B or D82C; however, there may be small areas of irrigation on the farms which has not been captured on the WARMS database.

Table 6-4: Irrigation Water Use within Tertiary D82

QUATERNARY	VOLUME (M ³ /A)	AREA (HA)
D82A	36 486 000	1 880.2
D82B	45 000	3
D82F	1 975 500	131.7
D82G	7 474 500	498.3
D82K	0	0
D82L	8 290 990	555.6
Total	54 271 990	3068.8

Source: DWS WARMS Database

There are many water supply schemes along the length of the Orange River, as the water resources around the downstream Orange River are scarce, and therefore are supplied by the Gariep and Vanderkloof Dams, limiting the main water use to be alongside the river. Irrigation along the Orange River is the principal water use. The major schemes connected to the Orange River include (ORASECOM, 2012):

- Douglas Irrigation Scheme (part of the Orange-Vaal Transfer Scheme): The Scheme is located between 400-500 km's away from the study area at the downstream end of the Vaal River (its primary water source).
- Middle Orange Irrigation Area (includes irrigation along the riparian zone between Hopetown and Boegoeberg Dam: The area stretches from Hopetown to Boegoeberg Dam. The irrigators are not part of a formalised scheme with a common supply system, but rather abstract water directly from the Orange River individually. The scheme is located 300+ km's away from the study area.
- Keimoes Canal Irrigation Area: Keimoes irrigation area consists of various Irrigation Boards, each with its own diversions from the Keimoes Canal which obtains its water from the Orange River. The scheme is located 400+ km's away from the study area.
- Namakwaland Irrigation Area: The water for the Namakwaland Irrigation Area is abstracted from the Orange River. Water is released from Vanderkloof Dam to supply users in this area. The scheduled area is about 2 439 ha and too extensive to study in any further depth.
- Vioolsdrift and Noordoewer Irrigation Area (extends into Namiba): The irrigation areas are supplied through a canal system fed by the Vioolsdrift Weir on the Orange River. The scheme is operated by the Vioolsdrift and Noordoewer Joint Water Authority over a vast area.

Table 6-5 shows volumes of the remainder of water users within the tertiary.

Table 6-5: Water Users within Tertiary D82 (excluding irrigation)

QUATERNARY	VOLUME (m ³ /a)	SECTOR	SOURCE
D82A	12 000	Water supply service	Orange River
	4 000 000	Industry (urban)	Scheme
D82B	20 280	Livestock Watering	Borehole
D82C	16 060 000	Water supply service	Scheme
	3 500	Mining	Borehole
D82G	4 000	Water supply service	Scheme
D82H	35 200	Water supply service	Borehole
D82K	528 000	Industry (urban)	Scheme
	724 100	Industry (urban)	Scheme
	1 800	Mining	Scheme
D82L	2 000 000	Mining	Scheme

Source: DWS WARMS Database

6.8 GROUNDWATER

The topography of Farm RE86 is predominantly flat, with an average slope of 3.1% declining from the south west towards the north east. The elevation of the property ranges between 835 – 1009 meters above mean sea level (a.m.s.l), and characterised by 2 small mountain tops, which is typical of the area on the northern boundary.

The ranges of hills, mountains and inselbergs in the area display some of the most diverse and complex geology in Southern Africa including some of the richest known concentrations of copper, lead and zinc (Mining Technology, accessed 2016).

According to the original Environmental Management Programmes (EMPRs) the Aggeneys deposits occur in the Precambrian metavolcanic metasedimentary Bushmanland Group which forms part of the Namaqualand Metamorphic Complex. The Bushmanland Group is located within the Namaqualand-Natal Mobile Belt, with an area of approximately 18 000km² (RHDHV, 2013).

The project falls within the northern Aggeneys terrain of the Bushmanland Terrane group. The orebody at Gamsberg is hosted by iron sulphide-rich pelitic rocks and iron formation, and the economic mineralisation comprises sphalerite (zinc) and minor galena (lead).

The area includes deposits of zinc, lead, copper, and silver suitable for mining. A major zinc deposit containing mineral resources of 194Mt has been identified in the nearby Gamsberg inselberg (Mining Technology, accessed 2016). The underlying natural geology is considered to be representative of a poor aquifer, a low-yielding system of poor water quality with a low vulnerability to contamination and low susceptibility to anthropogenic activities.

Several boreholes over the area were identified with three representative boreholes chosen to be analysed for both yield and chemical constituents. It was found that the groundwater yield may be able to supplement the demand of the proposed solar energy facility.

The underlying natural geology is considered to be representative of a poor aquifer, a low-yielding system of poor water quality with a least vulnerability to contamination and the low susceptible to anthropogenic activities.

A water yield assessment was carried out by VSA Leboa Consulting (Pty) Ltd on three selected representative boreholes for the area. This data was used to determine the constant yield, sustainable yield and water quality.

It was found that the regional depth to groundwater is 30–50m bgl. However, from the water level measured from the boreholes, the water level is between 27.74 m and 79.59m bgl. Due to deep underground mining, it can be expected that the groundwater level will be induced to drop. Average borehole yields are less than 0.5l/s, mean annual recharge is between 1-5mm per annum with the mean annual precipitation of between 20-150mm per annum. Groundwater quality is dominated by sodium, potassium, chloride and sulphate ions, with dissolved solids typically ranging from 1000–1500mg/l.

Based on the pumping test conducted on BH133 and BH155, the hydraulic parameters are summarised in **Table 6-6**.

Table 6-6: Hydraulic parameters for boreholes

BH ID.	BH DEPTH (M)	STATIC WATER LEVEL (M)	DRAWDOWN AVAILABLE (M)	DRAWDOWN ACHIEVED (M)	DRAWDOWN ACHIEVED (%)	RECOVERY		CONSTANT Q (L/s)
						%	HRS	
BH133	77.28	41.24	36.04	12.09	33.55	97.78	8	1.56
BH155	59.55	27.74	31.81	22.26	69.98	91.25	10	1.29

No test was conducted for the third borehole as it failed during the step test. Each borehole comprise of three steps of one hour each

6.9

HERITAGE

The heritage specialist study was undertaken by ACO Associates and is included in **Appendix J**.

ARCHAEOLOGICAL BACKGROUND

EARLY AND MIDDLE STONE AGE

There is a widespread, but ephemeral distribution of stone artefacts of Pleistocene age across Bushmanland. The Early Stone Age (ESA), according to Morris (2013) includes Victoria West cores, long blades and a low incidence of handaxes and cleavers. According to Morris (2013) there is a Middle Stone Age (MSA) site on the top of the Gamsberg and at the base of hills. Orton (2013b) collected both ESA and MSA material from the top of the mountain. Webley & Halkett (2012) also recorded MSA stone artefact scatters to the north-east of the proposed development on the farm Aroams.

In their assessment of the Korana WEF, Hart et al (2014) recorded a few concentrations of MSA scatters, but otherwise no definable archaeological sites. Smith (2012) recorded a low density distribution of ESA and MSA flakes on the Zuurwater Solar Facility.

LATER STONE AGE

According to Morris (2013) the predominant archaeological resource in the area belongs to the Late Holocene Later Stone Age. Orton & Webley (2013) note that the pre-colonial archaeology is strongly linked to landscape features. Ephemeral LSA scatters are found across the area and are generally in close proximity to fountains, small, seasonal pans or hollows in the bedrock which collect seasonal rainfall (“klipbakke”). More substantial herder encampments are found along the Orange River floodplain (Morris & Beaumont 1990), reflecting “the higher productivity and carrying capacity” along the river. After good rains, herders may have moved from the Orange River into Bushmanland, as indicated at sites near Aggeneyys with pottery and the archaeological site of Schuitdrift South east of Pofadder (Morris 1999a). Beaumont et al (1995) have argued that the arrival of the herders around 2000 years ago, may have led to competition for resources and the marginalisation of hunter-gatherers who may have made more frequent use of the Bushmanland resources.

Morris (2013) refers to grinding grooves in the rock outcrops of the Aggeneys/Gamsberg area. Similar grinding grooves in the bedrock have been recorded on the Pofadder WEF (Orton & Webley (2012b) to the east of the study area and at the Kangnas WEF (Orton & Webley 2012a) to the west of the study area. A single site with rock paintings (consisting of simple finger paintings including two star motifs and an indented oval shape image) has been recorded from a boulder alongside the Aggeneys/Black Mountain aggregate quarry. Morris (2013) also refers to some engraved cupule sites at two sites on the Black Mountain Mining Property, Aggeneys and at the foot of the Swartberg on Zuurwater 62 (Morris 2013). This appears to be similar to the cupule site recorded by Orton & Webley (2012a) on the Kangnas WEF site some distance to the west.

In fieldwork conducted by Webley & Halkett (2011) for a new transmission line commencing at the Aggeneis substation, it was observed that LSA sites (consisting mainly of quartz flakes) were concentrated at the base of small koppies.

HISTORICAL BACKGROUND

Penn (1995) has summarised the colonial history of this frontier zone for the Aggeneys and Gamsberg areas. The area adjacent Aggeneys was visited by eighteenth and nineteenth century explorers (Thompson 1827; Dunn 1931; Robinson 1978). Many of the local place names are of Khoe -San origin. Thompson (1827) recorded that the local people were known as the “Obseses”, they were a formidable amalgamation of various tribes who had been involved in conflict with bands of Afrikander.

The indigenous groups faced onslaughts from the 1770s and by the end of the 19th century the independent San groups had disappeared. There are references to a massacre of San groups in a kloof at Aggeneys although other sources link the killing of the Bushmen with Gamsberg rather than Aggeneys. Morris (2010) notes that recently appreciation has started to emerge regarding the “genocide of the Bushmen in this area, with certain mountainous areas (like the Gamsberg) being likely massacre sites”.

There are various interpretations of the name Aggeneys (original spelling Aggeneis). Nienaber & Raper (1977) list “Place of Water”, “Place of Blood”, “Place where they slaughtered” or possibly “Place of red clay”. Pella was originally known as “Kammas”, which means “fountain with water”.

According to a British Intelligence Map of 1900 (**Figure 6-19**), the wagon track across Bushmanland ran past Aggeneys, and then south of the Gamsberg, through the village of Namies which now lies in ruins. We know from Burke (1995) that during the Anglo-Boer War skirmishes in the Northern Cape around 1901, there were approximately 200 Boers at Namies. Aggeneys itself, which also had an important water source, was also held by a small Boer commando unit. The farm at Aggeneys was acquired by a former British soldier in 1905 and the ruins of the original farmhouse are still visible. There was some Boer war action around Aggeneys and the old fortifications are apparently visible on the valley sides.

The village of Namies was an important water supply point for people trekking across Bushmanland and was the last water stop before Gamoep, some 100km to the southwest (Eksteen 2012; Orton & Webley 2013). After good rains, the Trekboers used to camp at Namies. Namies was abandoned around 1923, when Pofadder became the most important town in the area. According to **Figure 6-19**, there was a track which ran through the eastern section of the Hartebeest Vlei 86. A pan in the south part of farm was called Goneroop.

The first known investigation of the mineral potential of the Aggeneys area dates to 1928, while the first mining at Swartberg (Black Mountain) dates to the 1970s.

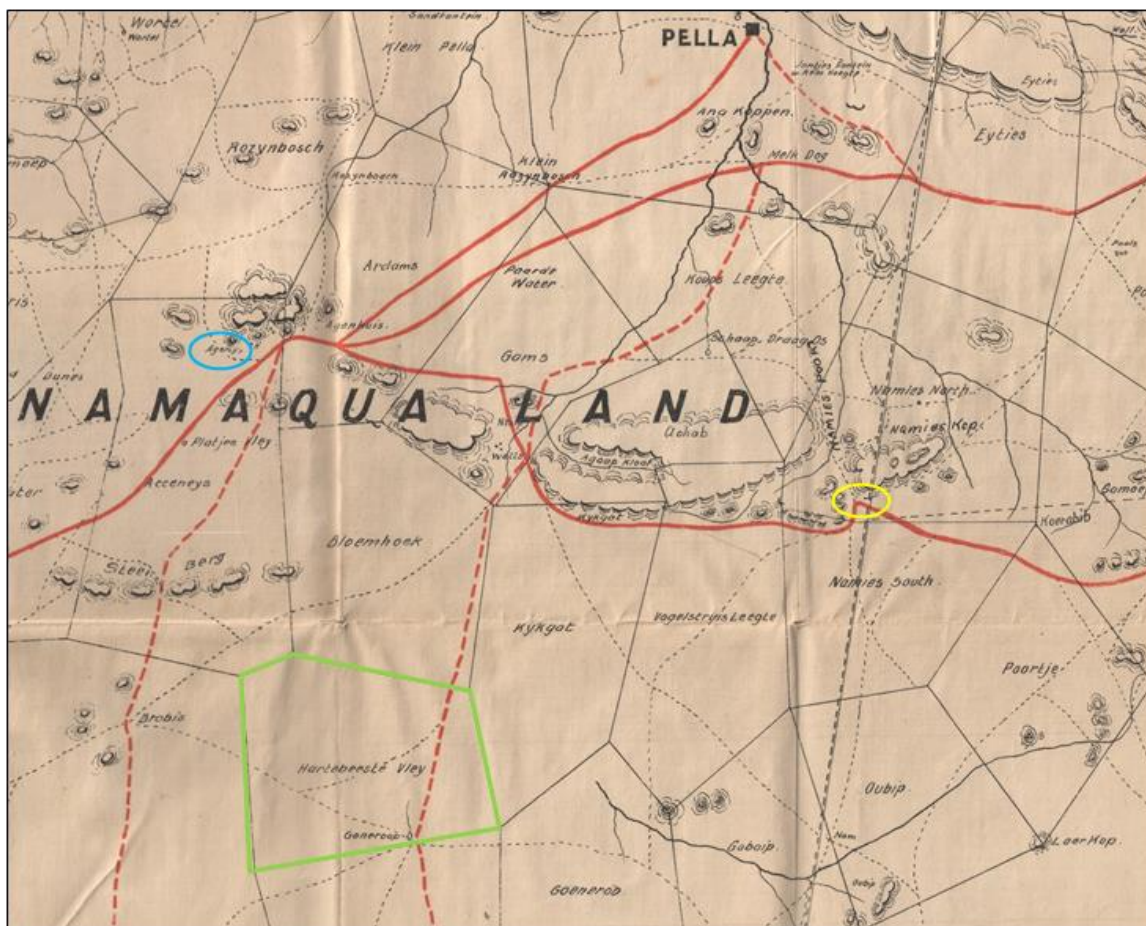

Figure 6-19: Map compiled by the British Intelligence Department (1900) of Bushmanland (scale 1:250 000). Note the position of Hartebeest Vlei. The location of Aggeneys is shown in blue, and Namias is shown in yellow

CEMETERIES AND GRAVES/CAIRNS

Graves are occasionally recorded next to old farmsteads. Morris (2011) recorded some stone cairns, possibly pre-colonial burials, to the north-west of the Gamsberg.

LANDSCAPE AND SCENIC ROUTES

The only aspect of the landscape which has been identified as being of cultural significance is the Gamsberg some 12km to the north-east. Morris (2010) observes that there has been some discussion around including the Gamsberg into a potential / Xam and Khomani Heartland World Heritage Site, but there has been no progress on this matter since 2010.

The N14 which runs 10km north of the study area can be considered a scenic route because of the aesthetic qualities of the surrounding landscape. However, the distance between the site and the study area means it is unlikely that the project will be visible from the road.

6.10 PALAEOLOGY

The palaeontological specialist study was undertaken by NaturaViva and is included in **Appendix K**.

Mid Proterozoic basement rocks of the Namaqua-Natal Province are entirely unfossiliferous (Almond & Pether 2008). Fossil biotas recorded from each of the main sedimentary rock units mapped in the Aggeneys region and along the Orange River to the north have been reviewed in several previous palaeontological heritage assessments by the author Almond (e.g. 2011, 2012, 2013a, 2013b, 2014; see also Almond & Pether 2008, Almond 2009, Almond in Macey et al. 2011 and extensive references therein).

An important Early to Middle Miocene vertebrate faunule has been recorded from alluvial deposits (gravels, grits and lenses of sand, clay) of the Koa River Palaeo-valley system at Bosluis Pan, some 50 km SSW of Aggeneys. The fossil fauna has been dated to 15-16 Ma and is reviewed by Senut et al. (1996; see also Malherbe et al. 1986, De Wit 1999, Partridge et al. 2006, Agenbacht 2007, Almond in Macey et al. 2011). It includes rare bones, tusks, molars and numerous tooth fragments of Gomphotherium, a four-tusked, browsing proboscidean with characteristic rounded (mastodont) tooth cusps. There are also crocodile teeth and tortoise shell fragments, as well as remains of grazing elephant shrews, giraffids, bovids, a rhinocerotid and air-breathing catfish. However, fossiliferous fluvial sediments have not yet been recorded from the northern sector of the Koa River Valley near Aggeneys; if present, they are likely to be deeply buried beneath superficial sediments (e.g. younger alluvium, aeolian sands). Significant impacts on subsurface fossils within the study area - where deep excavations are not involved - are therefore not anticipated.

The various younger superficial deposits of the Kalahari Group in Bushmanland, including aeolian sands, alluvium, calcretes and pan deposits, are poorly known in palaeontological terms. The fossil record of the Kalahari Group as a whole is generally sparse and low in diversity; no fossils are recorded here in the Pofadder and Onseepkans geology sheet explanations by Agenbacht (2007) and Moen and Toogood (2007) respectively. The Kalahari beds may very occasionally contain important Late Cenozoic fossil biotas, notably the bones, teeth and horn cores of mammals as well as remains of reptiles like tortoises, non-marine molluscs (bivalves, gastropods), ostrich egg shells, trace fossils (e.g. calcretised termitaria, coprolites), plant remains such as peats or palynomorphs (pollens, spores) in organic-rich alluvial horizons as well as siliceous diatoms in pan sediments. Calcrete hardpans might also contain trace fossils such as rhizoliths, termite nests and other insect burrows, or even mammalian trackways.

6.11 VISUAL

The visual specialist study was undertaken by Belinda Gebhardt and is included in **Appendix L**.

VISUAL CHARACTER

Landscape character is the description of the pattern of the landscape, resulting from particular combinations of natural (physical and biological) and cultural (land use) factors. It focuses on the inherent nature of the land. The basis for the visual character of the area is therefore provided by the underlying geology and climate.

The area is very arid and hot with very low average rainfall. This, together with the geology has resulted in expansive dry plains, with low growing, xerophytic plants interspersed with protruding rocky land forms.

These land forms provide dramatic, rugged focal points, emphasised by the flat, low nature of the plains and the high clear skies and serve as backdrops to the landscape, when viewed from a distance (**Figure 6-20**). The colours of the land are soft greys and muted greens against rich reddish browns which contrast dramatically with the high blue skies, sometimes scattered with cloud. Occasional clusters of trees, the only taller vegetation in the region, dot the landscape and are visually conspicuous features in the landscape.

The land-use in the area does not significantly alter the natural visual character. The study area is remote and sparsely populated, with less than 1 person per km². Patterns of the long straight roads,

power lines and fences, with few dwellings or other man-made structures add to the sense of barrenness and isolation. As noted above, this character is likely to change when proposed Wind Energy Facilities in the vicinity are constructed. The tall, clean lines of the turbines will create a more futuristic, modern character which is likely to dominate the immediate visual landscape.



Figure 6-20: Visual Character, clear skies flat plains and koppies

SENSE OF PLACE

An area will have a stronger sense of place if it can easily be identified, that is to say if it is unique and distinct from other places. Lynch defines ‘sense of place’ as “the extent to which a person can recognise or recall a place as being distinct from other places – as having a vivid or unique, or at least a particular, character of its own” (Lynch, 1992:131).

The visual character of the study area, while strikingly unique regionally, is typical of large areas of the Northern Cape and southern Namibia. The greater area is definable by its stark, dry landscape and feeling of remote stillness. The sites are recognisable in the landscape by the two koppies which flank them, but are not strikingly different or recognisable from the vast areas of surrounding land. The Gamsberg inselberg to the north-west of the study area is a unique landform, with a very distinct visual character, primarily due to its unusual topographical form.

VISUAL QUALITY

Aesthetic value is an emotional response derived from our experience and perceptions. As such, it is subjective and difficult to quantify in absolute terms. Studies in perceptual psychology have shown that humans prefer landscapes with higher complexity (Crawford, 1994). Landscape quality can be said to increase when:

- Natural landscape increases and man-made landscape decreases;
- Well-preserved, compatible man-made structures are present;
- Diverse or vivid patterns of grasslands and trees occur;
- Water forms are present;
- Topographic ruggedness and relative relief increases; and
- Where land use compatibility increases (Crawford, 1994, Arriaza, 2004).

Greater aesthetic value is also attached to places where:

- Rare, distinguished or uncommon features are present;
- The landscape/townscape evokes particularly strong responses in community members or visitors;
- The landscape/townscape has existing, long-standing meaning or significance to a particular group; and
- Landmark quality features are present. (Ramsay, 1993).

Visual quality therefore is an estimation of the composition of landscape and man-made elements and their resulting visual or scenic excellence.

The vast, arid plains of the Northern Cape and southern Namibia interspersed with rugged rocky, koppies contrast dramatically with the striking blue skies and create a landscape which is appealing in its expanse and remote, arid nature.

While not symbolic, the vastness of this desolate and remote landscape is evocative. These visual features create a landscape pattern that can be said to currently have a relatively high visual quality due to the high visual integrity, the general absence of intrusive, man-made features and the unusual visual character of the desolate arid plains interrupted by koppies. When the area is developed as a REDZ the concentration of turbines will alter the visual character, compromising the rural character and providing a cleaner, more futuristic or modern character. The aesthetic appeal of this altered landscape is subjective.

6.12 SOCIAL ENVIRONMENT

The social specialist study was undertaken by WSP | Parsons Brinckerhoff and is included in **Appendix M**.

SOCIO-ECONOMIC CONTEXT

The proposed project is located within Northern Cape Province (**Figure 6-21**). This is one of the largest provinces within South Africa, taking up nearly a third of the country's land area, but has the country's smallest population. The population density of the province is therefore very low (approximately 1 person per square kilometre) (Statistics South Africa, 2016). On a geographical basis, the province shares borders with Namibia in the north and stretches as far as the Atlantic Ocean in the west. The Northern Cape also shares borders with the Western Cape to the south, the Eastern Cape to the southeast, and the Free State and the North West Province to the east. The largest centres in the Northern Cape are Kimberley and Upington. Kimberley was founded on the mining industry, but most mineshafts in Kimberley have been closed, thus the traditional economic base of the city has been eroded, and there is a need to look for alternative activities to sustain its local economy. Upington's (population ~47000) local economy is based on services, agriculture and agro-industry, and long-term sustainability is not a particular issue. It is, however, an issue in the northern areas of the province where mining has taken over from extensive agriculture.

The sparse, arid landscape is dominated by extensive sheep, goat, and cattle rearing, as well as mining (including diamonds, iron, titanium, zinc, lead, and copper). The Northern Cape mining industry makes up nearly 7% of South Africa's total mining value and contributes 23.4% to the province's total economy. Farmers in the province contribute to 6.1% to South African agriculture and 6.6% of the province's economy (Statistics South Africa, 2012). The Orange River provides a source of fertile land and water within the northern region of the province. The areas immediately adjacent to Orange River are therefore characterised by a concentration of vineyards and other intensive agricultural activities, producing products such as export-quality table grapes, wine, dried and preserved fruit. The Northern Cape is also home to the world's largest telescope, the Square Kilometre Array (SKA). The province has numerous parks and conservation areas. The Kgalagadi

Transfronteir Park is Africa's first cross-border game park and one of the largest conservation areas in southern Africa.

The Namakwa District Municipality, in which the study area is located, is one of five districts of the Northern Cape Province and comprises six local municipalities. Namibia forms the northern border and the Atlantic Ocean the western border. This municipality has the lowest population within the province, with just over 100 000 people spread over the municipality, and concentrated within small to medium-sized settlements and towns.

The local economy is natural resource-based, primarily dependant on extensive livestock farming. The mining sector, however, is the dominant economic sector (52% to Gross Domestic Product). Recent trends in the mining sector, however, show the sector to be in decline. Increasing levels of unemployment have resulted in increased pressure on the employed population and a high dependency on the State for support. A decline in employment opportunities in the mining sector emphasises the need to prioritise alternative sectors (Namakwa IDP, 2012).



Figure 6-21: Regional location of proposed project

LOCAL CONTEXT

The local context refers to the area surrounding the study area contextualised within local municipality. The study area is located within Ward 4 of the Khâi-Ma Local Municipality, which lies in the northern region of the Namakwa District Municipality, bordering on Namibia. The seat of local government is located in the town of Pofadder, and the four main economic sectors are livestock grazing, agriculture, mining and tourism (Khâi-Ma IDP, 2012).

The Khâi-Ma Local Municipality covers an area of approximately 16 600 km², and has a population of approximately 12 500 people, resulting in a very low population density of less than 1 person per square kilometre (Statistics South Africa, 2012). The municipality is characterised by vast tracts of flat, undeveloped and arid Karoo landscape, with scattered mountainous areas, and ephemeral rivers. The majority of the population live within urban areas (82.8%), with only 17.2% living in rural areas (Statistics South Africa, 2012). As a result the local service levels are reasonable, with 89.6% of the households having access to electricity for lighting 84.3% for cooking and 50.8% for heating. Almost 70% of potable water is provided by the municipality and other water service providers, and 8.4% is sourced from boreholes.

Education levels are characteristically low, with 7.1% having completed their primary and 9.8% having completed secondary education (Statistics South Africa, 2012). This is likely to be due to the lack of access to secondary and tertiary education within the municipality. Resultantly the majority of the local population is likely to be unskilled, or have basic (elementary) skills in terms of the employment market. The income levels in the region reflect this trend, with 73.5% earning less than R1 600 per month. The unemployment levels are high with 31.8% of the potential labour force being unemployed, compared to the current national unemployment rate of 25.4% (Statistics South Africa, 2016). The main economic sectors within the Khâi-Ma Local Municipality are mining, agriculture, tourism, and community and social services. The majority (77%) of employed persons fall within the formal sector, and 15% within the informal sector (Statistics South Africa, 2012).

LOCAL ECONOMIC ACTIVITIES

The main activity within the local area is mining. Approximately 14 km north of the study area lies the town of Aggeneys, which is a mining town that was developed in support of the Black Mountain Mine (BMM), located in the same vicinity. This mine primarily produces zinc and lead, as well as copper and silver, and is the main source of employment within the local area. BMM employs approximately 1 300 people, 700 permanently and the remainder on a contract basis (ERM, 2013). BMM provides basic services (including free potable water) to the staff housed at Aggeneys, as well as water to surrounding the towns of Pofadder and Pella, and surrounding farmers (a total of 11 200 people) (ERM, 2013). In 2015, BMM commenced excavation on the Gamsberg Mine, located approximately 10 km northeast of the study area. This mine is proposed to employ up to 3 200 people during the construction phase (highly skilled to low-skilled) over 30 months of construction, and approximately 100 people during the operational phase (ERM, 2013).

After mining, there are two other key local economic activities namely agriculture and tourism. Agricultural activities include intensive crop and fruit farming along the Orange River, and extensive sheep and goat farming. Tourism related activities are centred around the Orange River, the Namaqualand region (wildflowers, cultural and nature conservation tourism), and national wildlife reserves within the Northern Cape such as the Richtersveld and Kgalagadi National Parks.

Development in the area appears to be centred on renewable energy generation and associated infrastructure. Currently there are several proposed projects within a 100 km radius of the study area, and one existing facility.

LOCAL COMMUNITIES

The key centres within the Khâi-Ma Local Municipality are Pofadder, Aggeneys, Pella, Witbank and Onseepkans (**Figure 6-22**). The remote nature of the study area from public services (i.e. local towns) means that there are few rural or farming settlements on or within the vicinity of the study area. Scattered farming settlements are present north of the study area along the Orange River near Pella, Witbank and Onseepkans, as well as to the northeast around Pofadder. **Table 6-7** provides a summary of these communities, and their relative distance from the study area.

Table 6-7: Description of Local Communities

TOWN	DESCRIPTION	DISTANCE & DIRECTION FROM STUDY AREA
Aggeneys	The small town of Aggeneys is located adjacent to the BMM. The town was developed in the 1970s to accommodate mine staff, and comprises residential housing, a police station, basic retail and a private airstrip. The population is estimated at 2 053 with approx. 666 households (Khâi-Ma IDP, 2011).	14 km northeast
Pella	Pella is a small town, located at the base of the Pella Mountains on the Orange River, with a population of approximately 2 500 people (Statistics South Africa, 2012). The town supports the local farming and the Aggeneys mining communities.	40 km northeast
Pofadder	The town is situated along the N14, and is an agricultural centre for the surrounding farming community. The town has approximately 808 households and estimated population of 2919 people (Khâi-Ma IDP, 2011)	50 km northeast
Witbank	Witbank is a hamlet of approximately 80 households. Although little information is available about the settlement, it is likely to support the local agricultural sector.	60 km north, northwest
Onseepkans	Onseepkans is a small, scattered settlement located on the Orange River. The community comprises farming settlements (farm houses and staff accommodation) and is a border post between South Africa and Namibia.	80 km northeast

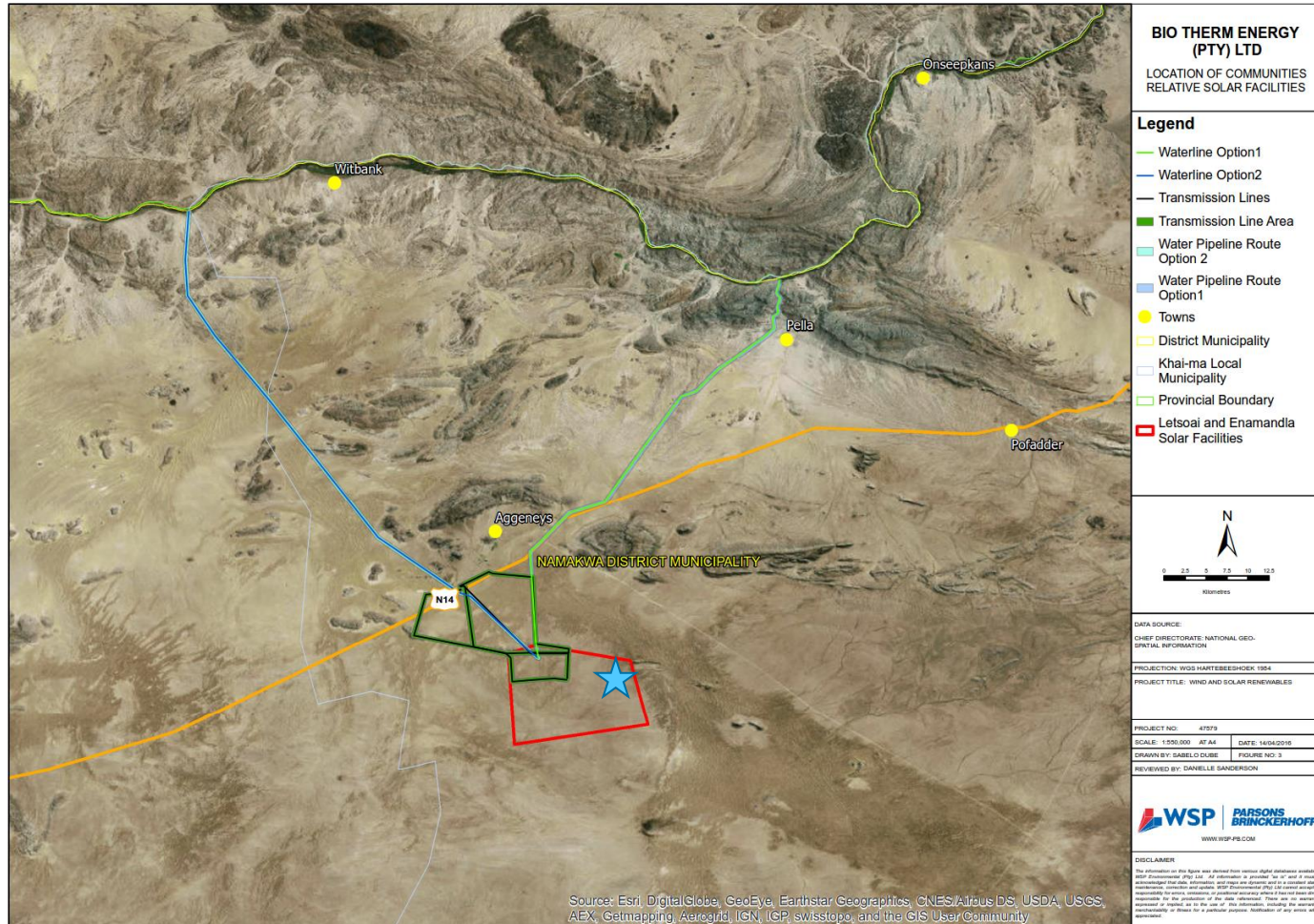

Figure 6-22: Local Context of the Proposed Project (Enamandla PV 5 indicated with a blue star)

7 IDENTIFICATION OF POTENTIAL IMPACTS

7.1 PHASES OF DEVELOPMENT

Potential impacts have been identified and assessed according to the phases of the project's development. For purposes of this report, these phases have been generically defined below.

→ Construction Phase:

The construction phase includes the preparatory works/activities typically associated with the creation of surface infrastructure, access and electrical power. The activities most relevant to this phase include:

- Topsoil stripping;
- Cut and fill activities associated with site preparation (if required)
- Construction of the surface infrastructure including the PV panels and support frames, invertors, site substation, laydown areas, operational and maintenance facilities and internal powerlines;

→ Operation Phase:

The operational phase includes the daily activities associated with the functioning of the PV facility.

→ Decommissioning Phase:

The decommissioning phase includes the activities associated with the removal/dismantling of machinery/equipment/infrastructure no longer necessary to the operation.

7.2 ACTIVITIES MATRIX

The impacts below have been assessed according to environmental categories. **Table 7-1** provides an indication of how these environments are linked to the various NEMA listed activities outlined in Chapter 4.

Table 7-1: Activities Matrix (C – Construction, O – Operation, D – Decommissioning)

ACTIVITY DESCRIPTION	TOPOGRAPHY	GEOLOGY	CLIMATE	SOIL AND LAND CAPABILITY	NATURAL VEGETATION AND ANIMAL	AVIFAUNA	SURFACE WATER	GROUND WATER	HERITAGE	PALAEONTOLOGY	VISUAL	TRAFFIC	SOCIAL
GNR 983- Listing Notice 1													
Activity 11: The development of facilities or infrastructure for the transmission and distribution of electricity- (i) Outside urban areas or industrial complexes with a capacity of more than 33 but less than 275 kilovolts.	C D	-	-	C O D	C O D	C O D	C D	-	C D	C D	C O D	-	C D
Activity 14: The development of facilities or infrastructure, for the storage, or for the storage and handling, of a dangerous good, where such storage occurs in containers with a combined capacity of 80 cubic metres or more but not exceeding 500 cubic metres.	C D	-	-	C D	C D	C D	C D	C D	C D	C D	-	-	-
Activity 24: The development of- (ii) A road with a reserve wider than 13,5 meters, or where no reserve exists where the road is no wider than 8 meters.	C D	C D	-	C O D	C O D	C O D	C D	-	C D	C D	C O D	C O D	C O D
Activity 28: Residential, mixed, retail, commercial, industrial or institutional developments where such land was used for agriculture or afforestation on or after 01 April 1998 and where such development: (ii) Will occur outside an urban area, where the total land to be developed is bigger than 1 hectare.	C D	C D	-	C O D	C O D	C O D	C O D	-	C D	C D	C O D	C D	C O D

ACTIVITY DESCRIPTION	TOPOGRAPHY	GEOLOGY	CLIMATE	SOIL AND LAND CAPABILITY	NATURAL VEGETATION AND ANIMAL	AVIFAUNA	SURFACE WATER	GROUND WATER	HERITAGE	PALAEONTOLOGY	VISUAL	TRAFFIC	SOCIAL
Activity 56: The widening of a road by more than 6 metres, or the lengthening of a road by more than 1 kilometre- (i) Where the existing reserve is wider than 13,5 meters; or (ii) Where no reserve exists, where the existing road is wider than 8 metres.	C D	C D	-	C O D	C O D	C O D	C D	-	C D	C D	C O D	C O D	C O D
GNR 984- Listing Notice 2													
Activity 1: The development of facilities or infrastructure for the generation of electricity from a renewable resource where the electricity output is 20 megawatts or more, excluding where such development of facilities or infrastructure is for photovoltaic installations and occurs within an urban area.	C D	C D	-	C O D	C O D	C O D	C O D	C O D	C D	C D	C O D	C D	C O D
Activity 15: The clearance of an area of 20 hectares or more of indigenous vegetation, excluding where such clearance of indigenous vegetation is required for- (i) the undertaking of a linear activity; or (ii) maintenance purposes undertaken in accordance with a maintenance management plan.	C D	C D	-	C O D	C O D	C O D	C O D	-	C D	C D	C O D	C D	C O D
GNR 985- Listing Notice 3													

ACTIVITY DESCRIPTION	TOPOGRAPHY	GEOLOGY	CLIMATE	SOIL AND LAND CAPABILITY	NATURAL VEGETATION AND ANIMAL	AVIFAUNA	SURFACE WATER	GROUND WATER	HERITAGE	PALAEONTOLOGY	VISUAL	TRAFFIC	SOCIAL
<p>Activity 14: The development of a road wider than 4 metres with a reserve less than 13,5 metres. In The Northern Cape - (ee) Critical biodiversity areas as identified in systematic biodiversity plans adopted by the competent authority or in bioregional plans</p>	C D	C D	-	C O D	C D	C O D	C D	-	C D	C D	C O D	C O D	C O D
<p>Activity 12: The clearance of an area of 300 square meters or more of indigenous vegetation except where such clearance of indigenous vegetation is required for maintenance purposes undertaken in accordance with a maintenance management plan In the Northern - (i) Within critical biodiversity areas identified in bioregional plans</p>	C D	C D	-	C O D	C O D	C O D	C O D	-	C D	C D	C O D	C D	C O D
<p>Activity 14: The development of – (xii) infrastructure or structures with a physical footprint of 10 square meters or more In the Northern Cape (ff) Critical biodiversity areas or ecosystem service areas as identified in systematic biodiversity plans adopted by the competent authority or in bioregional plans;</p>	C D	C D	-	C O D	C O D	C O D	C O D	-	C D	C D	C O D	C D	C O D

7.3 TOPOGRAPHY

SENSITIVE AREAS

No sensitive topographical areas were identified in the study area.

IMPACT IDENTIFICATION

→ Change in the site micro-topography

The development of infrastructure such as PV panels, internal access roads, fencing, etc. will result in the need for site clearance, top soil removal and earthmoving activities associated with road and infrastructure construction. These activities will result in a minor change in the topographical profile of the site.

Secondary impacts associated with change relate to changes in the on-site stormwater flow, and associated potential for soil erosion – see separate impact descriptions.

→ Change in study area macro-topography

The combined Enamandla and Letsoai projects will not result in significant changes in the vertical ground profile within the study area; as such impacts on the regional topography are not anticipated.

SIGNIFICANCE SCREENING

The significance screening of the above mentioned impacts is outlined in **Table 7-2**.

Table 7-2: Impact Significance Screening for Potential Topography Impacts

IMPACT	PHASE	CHARACTER	PROBABILITY	CONSEQUENCE	SIGNIFICANCE
Change in the site micro-topography	C, O	Negative	2	1	Very Low
Change in study area macro-topography	C, O	Negative	1	1	Very Low

POTENTIAL MITIGATION MEASURES

Due to the low impact significance, mitigation measures are not considered to be necessary.

FURTHER STUDIES RECOMMENDED IN THE EIA PHASE

No further studies are recommended.

7.4 GEOLOGY

SENSITIVE AREAS

No sensitive geological areas were identified in the study area.

IMPACT IDENTIFICATION

→ Disturbance to underlying geology

During the construction phase site preparation will be required in terms of vegetation clearance and bulk earthworks. In addition either concrete or rammed pile foundations will be required

for the erection of the PV panels. Even though these activities will be extensive in terms of their coverage of the site they will be relatively shallow (<2m). Therefore the impact on the underlying geology is considered to be negligible.

SIGNIFICANCE SCREENING

The significance screening of the above mentioned impacts is outlined in **Table 7-3**.

Table 7-3: Impact Significance Screening for Potential Geology Impacts

IMPACT	PHASE	CHARACTER	PROBABILITY	CONSEQUENCE	SIGNIFICANCE
Disturbance to underlying geology	C	Negative	2	1	Very Low

POTENTIAL MITIGATION MEASURES

Due to the low impact significance, mitigation measures are not considered to be necessary.

FURTHER STUDIES RECOMMENDED IN THE EIA PHASE

No further studies are recommended.

7.5

CLIMATE

SENSITIVE AREAS

No sensitive climatic issues were identified in the study area.

IMPACT IDENTIFICATION

→ Climatic impacts such as greenhouse effect and perceived global warming, as well as the phenomenon of acid rain

Potential impacts relate to climate change associated with GHG emissions associated with project. The manufacturing of the materials associated with the project, and associated transportation to site will result in indirect GHG emissions. There will be no GHG emissions directly associated with power generation from the facility in the operational phase due to the nature of the technology.

→ Contribution of cleaner energy to the National Grid

The project may be regarded as having a positive impact in terms of GHG emissions associated with the development of power generation capacity in South Africa i.e. less GHG emissions per unit of power contributed when compared to conventional fossil fuel derived power.

SIGNIFICANCE SCREENING

The significance screening of the above mentioned impacts is outlined in **Table 7-4**.

Table 7-4: Impact Significance Screening for Potential Climate Impacts

IMPACT	PHASE	CHARACTER	PROBABILITY	CONSEQUENCE	SIGNIFICANCE
Climatic impacts such as greenhouse effect and perceived global warming, as well as the phenomenon of acid rain.	C / O	Negative	2	1	Very Low

IMPACT	PHASE	CHARACTER	PROBABILITY	CONSEQUENCE	SIGNIFICANCE
Contribution of cleaner energy to the National Grid	O	Positive	4	3	High

POTENTIAL MITIGATION MEASURES

Due to the fact that the proposed development will have no impact on climate, mitigation measures are not deemed necessary.

The implementation of the project can be regarded as having a mitigatory effect in terms of contributing to the curbing of South African's CO₂ emission increases.

FURTHER STUDIES RECOMMENDED IN THE EIA PHASE

No further studies are recommended.

7.6 SOILS AND LAND CAPABILITY

SENSITIVE AREAS

No sensitive areas were identified in terms of land capability during the scoping phase.

IMPACT IDENTIFICATION

The following impacts on land capability have been identified:

→ Reduction in land available for grazing animals

During the construction, operational and decommissioning phases there will be a reduction in land available for grazing animals due to the occupation of the project and its associated infrastructure within the footprint of the development.

→ Soil erosion resulting in degradation of soil structure

During the construction and operational phases there will be an increase likelihood of soil erosion, due to vegetation clearance, soil disturbance and increased vehicle traffic within the footprint of the development. Secondary impacts associated with soil erosion relate to potential suspended solids and turbidity impacts on nearby surface water features – see separate impact description.

→ Degradation of soil due to contamination

During the construction phases there is potential for soil contamination associated with potential releases of environmental contaminants and hazardous substances (typically sewage / portable toilet chemicals, cement, oil, grease, and fuel). Secondary impacts relate to potential chemical contamination of nearby surface water features due to the transport of contamination during rainfall events – see separate impact description.

CUMULATIVE IMPACTS

The anticipated impacts for the proposed neighbouring solar and wind energy projects is considered to the same as those identified for the BioTherm project, with the exception of the proposed developments intersecting an ephemeral watercourse. As in the case of this report, each of the neighbouring sites should be investigated individually, following the format of an initial scoping

phase and a more in-depth EIA phase. Attention should be given to the affected ephemeral watercourses by these proposed developments.

SIGNIFICANCE SCREENING

The significance screening of the above mentioned impacts is outlined in **Table 7-5**.

Table 7-5: Impact Significance Screening for Potential Soil and Land Capability Impacts

IMPACT	PHASE	CHARACTER	PROBABILITY	CONSEQUENCE	SIGNIFICANCE
Reduction in land available for grazing animals	C / O / D	Negative	4	3	High
Soil erosion resulting in degradation of soil structure	C	Negative	2	2	Low
	O / D	Negative	1	1	Very Low
Degradation of soil due to contamination	C	Negative	2	2	Low
	O / D	Negative	2	1	Very Low

POTENTIAL MITIGATION MEASURES

The following potential mitigation measures have been identified:

- Areas of construction should be (practically) limited in extent, and activities outside of the site should be kept to a minimum.
- Soils excavated during construction of the facility should be appropriately stored in stockpiles which are protected from erosion (i.e. through use of vegetation cover in the case of long-term stockpiles).
- Due to the potential for wind erosion, wind-breaks may be required in areas where wind erosion occurs.
- Due to the flat topography water erosion is expected to be limited; however it should be rehabilitated if observed.
- Impacts that are expected to lead to long term degradation of soil quality (i.e. soil contamination) need to be limited through appropriate on-site management measures. This includes the proper handling and storage of hazardous materials, the use of hardstanding in areas where spillages are possible, the use of bunding around storage of hazardous materials and proper upkeep of machinery and vehicles.
- Due to the compaction and/or erosion of soils due to vehicles, traffic should be limited to existing or proposed roadways as far as possible.
- Vegetation removal should be kept to a minimum and limited to the area of development.

FURTHER STUDIES RECOMMENDED IN THE EIA PHASE

The land capability of the site comprises a combination of non-arable, low potential grazing land and wilderness areas; hence, the EIA phase investigation will be limited to a desktop study with subsequent targeted ground-truthing to confirm specific findings. Refer to detailed plan of Study (**Chapter 9**).

7.7 NATURAL VEGETATION AND ANIMAL LIFE

SENSITIVE AREAS

The sensitivity of the study area is indicated below in **Figure 7-1**; this shows that most of the development areas are within areas that are considered medium-low to medium sensitivity. Arid

grassland within Enamandla PV 5 is typically dominated by *Stipagrostis brevifolia* and *S.ciliata* with occasional *Parkinsonia africana* and *Rhigozum trichotomum*. The majority of the Enamandla PV 5 development area is considered medium-low sensitivity with some areas of deeper sands which are considered to be medium-high sensitivity. The majority of the area is considered suitable for development.

There are no sensitive features that would constrain the development within the Enamandla PV 5 site.

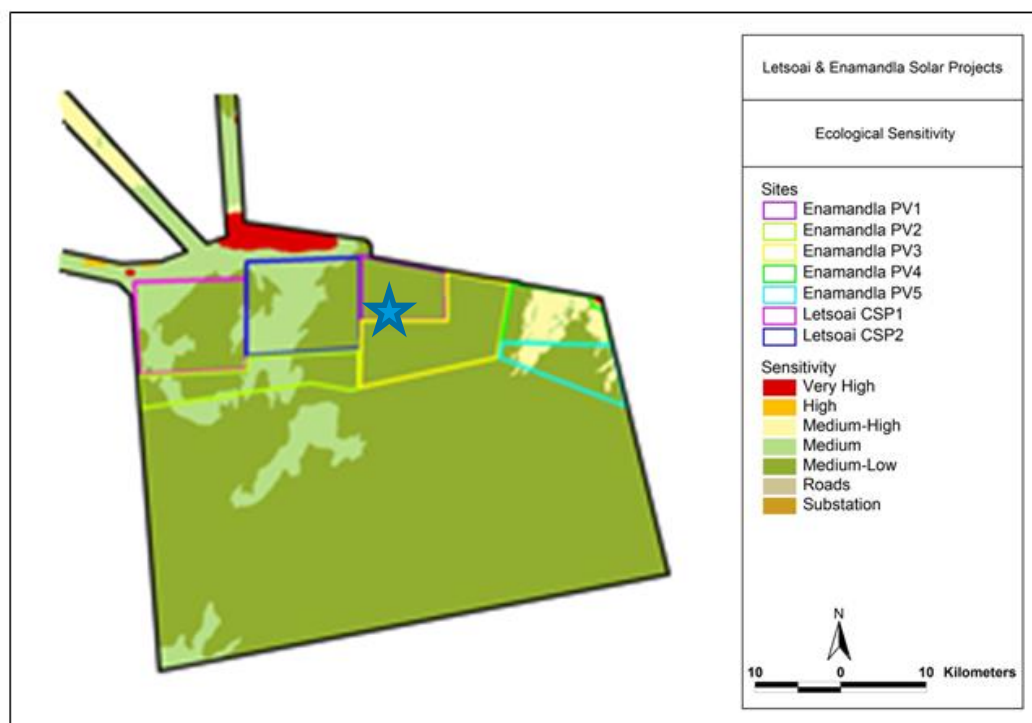

Figure 7-1: Biodiversity Sensitive Areas in relation to the Enamandla PV Site 1 (Blue Star)

IMPACT IDENTIFICATION

→ Disturbance, loss and transformation of vegetation

The construction of infrastructure including PV panels, internal access roads, fencing, etc. will result in the removal of or disturbance to vegetation. It is confirmed that some protected plant species occur within the Enamandla PV 5 site; it is highly likely that these will be impacted on by the development.

→ Impacts on fauna

The loss of vegetation associated with construction activities will have an impact on the faunal habitat function of the site. In addition, the noise, potential pollution, and human presence during the construction, operation and decommissioning phases may be detrimental to fauna. Sensitive and shy fauna would move away from the area as a result of the noise and human activities present, while some slow-moving species would not be able to avoid the construction activities and might be killed.

Some mammals or reptiles such as tortoises would be vulnerable to illegal collection or poaching during the construction phase as a result of the large number of construction personnel that are likely to be present.

→ Proliferation of alien invasive plant species

Current levels of plant invasion in the broader study area is low. During the construction and operational phases the disturbance of soil will generate favourable conditions for the establishment and spread of alien invasive plant species. Alien species such as *Prosopis* are however present and would potentially invade the study area along with other typical weedy species such as *Salsola kali*.

This impact is likely to be more prevalent in the operational phase and post decommissioning due to the relatively short duration of the construction phase.

→ Impacts on Broad-Scale Ecological Processes and Loss of Landscape Connectivity

The Enamandla PV 5 site is likely to be fenced and the cleared parts of the site are also likely to be hostile to many smaller fauna which will prevent or impede their movement across the landscape.

The Enamandla PV 5 project, Biotherm's broader Enamandla and Letsoai projects, and the other renewable energy developments in the area have the potential to cumulatively contribute to a loss of landscape connectivity. The significance of this impact at a cumulative level will need to be evaluated further in the EIA phase.

→ Effect on South Africa's commitment to conservation

The loss of unprotected vegetation types on a cumulative basis from the broad area may impact the countries' ability to meet its conservation targets. The receiving vegetation types in the study area are classified as Least Threatened and they are extensive vegetation types that are still more than 99% intact.

The development of the Enamandla PV 5 site would result in the loss of up to ~400ha of intact habitat which on its own is not considered highly significant, but as there is an array of other developments in the area, the possibility for significant cumulative impact on the affected vegetation types or on more localised plant communities is a potential concern, especially given the NPAES status of the site.

SIGNIFICANCE SCREENING

The significance screening of the above mentioned impacts is outlined in **Table 7-6**.

Table 7-6: Impact Significance Screening for Potential Biodiversity Impacts

IMPACT	PHASE	CHARACTER	PROBABILITY	CONSEQUENCE	SIGNIFICANCE
Disturbance, loss and transformation of vegetation	C	Negative	3	3	Medium
Impacts on fauna	C	Negative	3	3	Medium
	O / D	Negative	2	2	Low
Proliferation of alien invasive plant species	C	Negative	2	1	Very Low
	O / D	Negative	2	2	Low

IMPACT	PHASE	CHARACTER	PROBABILITY	CONSEQUENCE	SIGNIFICANCE
Impacts on Broad-Scale Ecological Processes and Loss of Landscape Connectivity	O	Negative	3	3	Medium
Reduced ability to meet conservation obligations & targets	O	Negative	3	3	Medium

POTENTIAL MITIGATION MEASURES

The following potential mitigation measures have been identified:

- Demarcate construction and operational areas by semi-permanent means/ material, in order to control movement of personnel, vehicles, providing boundaries for construction and operational sites and prevent unnecessary impacts outside authorised areas.
- Provide an adequate buffer between areas of development and surrounding natural habitat, prevent unnecessary degradation, pollution or damage to habitat outside authorised areas/approved footprint.
- Conduct a protected species survey prior to the commencement of construction activities.
- Compile and implement a suitable and detailed rescue and relocation programme for conservation important plants as identified within the development footprint.
- The size of areas subjected to land clearance will be kept to a minimum.
- Take steps to remove alien vegetation as per Conservation of Agricultural Resource Act (No. 43 of 1983).
- No animal shall be killed. Should any animal be identified within the development site, all work shall be stopped in order for the safe capture and removal of the animal from the site.
- All animals should be only handled by a competent person, with particular reference to snakes.

FURTHER STUDIES RECOMMENDED IN THE EIA PHASE

WETLAND ASSESSMENT

A wetland assessment will be undertaken on a desktop basis using available mapping resources. This will include a 500m buffer around the proposed boundaries of the development areas. Thereafter, a site visit will be undertaken to delineate wetlands identified within the development footprint. Given the arid nature of the development area near Aggeneys, with no watercourses currently identified within a 500m buffer, it is expected that site works will be largely non-onerous and will solely consist of a ground-truthing exercise to ensure that no unanticipated wetlands are present. Refer to detailed plan of Study (**Chapter 9**).

BIODIVERSITY ASSESSMENT

The scoping findings are based on a site visit, a desktop assessment of the study area as well as prior knowledge of the wider area resulting from previous work in the area. Additional assessment will be carried out in the EIA phase based on the final layout of the facility. The assessment will identify and quantify the abundance and distribution of species of conservation concern; identify faunal habitats; further evaluate corridor functioning; assess cumulative ecological impacts; assess cumulative habitat loss within the NPAES Focus area and the potential impact of this on future conservation options in the area. Refer to detailed plan of Study (**Chapter 9**).

7.8 AVIFAUNA

SENSITIVE AREAS

No sensitive areas were identified in terms of avifauna during the scoping phase.

IMPACT IDENTIFICATION

The full spectrum of impacts of solar facilities on birds is only now starting to emerge from compliance reports at solar facilities. In terms of their applicability to Enamandla PV 5, these can be summarised as follows:

→ **Temporary displacement of avifauna due to construction, operation and decommissioning of the solar plant and associated infrastructure**

The construction and decommissioning of infrastructure including PV panels, internal access roads, fencing, etc. will result in a significant amount of movement and noise leading to displacement of avifauna from the site. It is highly likely that most priority species will vacate the area for the duration of these activities.

→ **Permanent displacement of avifauna due to habitat transformation**

The removal of vegetation in the construction phase will result in a significant transformation of the existing natural faunal habitat. Once operational, the construction of the solar panels will prevent sunlight from reaching the vegetation below, which is likely to result in stunted vegetation growth and possibly complete eradication of some plant species.

Natural vegetation is likely to persist in the PV array field, albeit to a lesser extent with fewer shrubs, than the pre-construction conditions.

Table 6-3 lists the priority species that could potentially be affected by this impact. Small birds are often capable of surviving in small pockets of suitable habitat, and are therefore generally less affected by habitat fragmentation than larger species. It is, therefore, likely that many of the smaller passerine species will continue to use the habitat available within the solar facility albeit at lower densities. This will however differ from species to species and it may not be true for all of the smaller species. Larger species which require contiguous, un-fragmented tracts of suitable habitat (e.g. large raptors, korhaans and bustards) are more likely to be displaced entirely from the area of the proposed plant although in the case of some raptors (e.g. Southern Pale Chanting Goshawk, Lanner Falcon and Pygmy Falcon) the potential availability of carcasses or injured birds due to collisions with the solar panels may actually attract them to the area. The significance of the potential displacement impact is difficult to assess at this stage and will only become clear through operational phase surveys

→ **Collisions with the solar infrastructure (i.e. PV panels)**

The priority species that were recorded in the study area which could potentially be exposed to collision risk are listed in **Table 6-3**. The so-called “lake effect” could act as a potential attraction to some species and it is expected that flocking species i.e. Grey-backed Sparrow-lark, Namaqua Sandgrouse, Sociable Weaver and several species of doves as well as other passerines would be most susceptible to this impact as they habitually arrive in flocks at surface water to drink. Multiple mortalities could potentially result from this, which in turn could attract raptors e.g. Booted Eagle, Southern Pale Chanting Goshawk, Lanner Falcon and Pygmy Falcon which will feed on dead and injured birds which could in turn expose them to collision risk, especially when pursuing injured birds. In addition, the “lake effect” produced by the solar panels may potentially draw various water birds to the area. The unusually high number of waterbird mortalities at facilities which are all situated in extremely arid environments i.e. Desert

Sunlight facility (44%), Genesis (19%) and Ivanpah (10%) is noted in this respect. The presence of evaporation ponds may be an aggravating factor. The evaporation ponds, in combination with the “lake effect” might attract Greater and Lesser Flamingo. However, it is not possible to tell whether this will actually happen until post-construction monitoring reveals actual mortality at the site.

SIGNIFICANCE SCREENING

The significance screening of the above mentioned impacts is outlined in **Table 7-7**.

Table 7-7: Impact Significance Screening for Potential Avifauna Impacts

IMPACT	PHASE	CHARACTER	PROBABILITY	CONSEQUENCE	SIGNIFICANCE
Temporary displacement of avifauna due to construction, operation and decommissioning of the solar plant and associated infrastructure	C, O, D	Negative	3	3	Medium
Permanent displacement of avifauna due to habitat transformation	O	Negative	3	4	High
Collisions with the solar infrastructure (i.e. PV panels)	O	Negative	2	2	Low

POTENTIAL MITIGATION MEASURES

The following potential mitigation measures have been identified:

- **Temporary displacement due to disturbance associated with the construction and decommissioning of the solar plant and associated infrastructure**
 - Construction activity should be restricted to the immediate footprint of the infrastructure.
 - Access to the remainder of the site should be strictly controlled to prevent unnecessary disturbance of priority species.
 - Measures to control noise and dust should be applied according to current best practice in the industry.
 - Maximum use should be made of existing access roads and the construction of new roads should be kept to a minimum, as far as possible.
 - The recommendations of the ecological and botanical specialist studies must be strictly implemented, especially as far as limitation of the construction footprint and rehabilitation of disturbed areas is concerned.
- **Permanent displacement due to habitat transformation**
 - Maximum use should be made of existing access roads and the construction of new roads should be kept to a minimum.
 - The recommendations of the ecological and botanical specialist studies must be strictly implemented, especially as far as limitation of the construction footprint and rehabilitation of transformed areas is concerned.
- **Collisions with the solar infrastructure (i.e. PV panels)**
 - Formal operational phase monitoring should be implemented once the solar arrays have been constructed. The purpose of this would be to establish to what extent displacement of priority species have taken place.
 - Carcass searches should be implemented to search the ground between solar arrays.

- Depending on the results of the carcass searches, a range of mitigation measures will have to be considered if mortality levels turn out to be significant, including minor modifications of panel and mirror design to reduce the illusory characteristics of troughs. What is considered to be significant will have to be established on a species specific basis by the avifaunal specialist, in consultation with birdlife South Africa.
- The exact protocol to be followed for the carcass searches and operational phase monitoring must be compiled by the avifaunal specialist in consultation with the plant operator before the commencement of operations.

FURTHER STUDIES RECOMMENDED IN THE EIA PHASE

The EIA phase will entail further accumulation and consolidation of the relevant avian data, possibly including the execution of baseline data collection work as specified by the scoping study, intended to inform the avian impact study. This is currently happening through an onsite monitoring programme which is aimed at providing a baseline picture of the avifauna over a period of a year. The EIA Phase will also entail a full assessment of the likely impacts and available mitigation options, based on the results of systematic and quantified monitoring which is currently taking place. This will include the systematic assessment of all the identified impacts. Refer to detailed plan of Study (**Chapter 9**).

7.9 SURFACE WATER

SENSITIVE AREAS

No sensitive areas were identified in terms of surface water during the scoping phase.

Given its arid nature, no watercourses or wetlands have currently been identified within a 500m buffer of the study area. Potential impacts include:

IMPACT IDENTIFICATION

→ Surface water contamination

During the construction phases there is potential for soil contamination associated with potential releases of environmental contaminants and hazardous substances (typically sewage / portable toilet chemicals, cement, oil, grease, and fuel).

Soil erosion, resulting in stormwater with high suspended solids load, is an additional potential source of contamination of watercourses.

Although there are no nearby watercourses, the above contaminants have the potential to be transported off-site, or into more distant watercourses by means of entrainment in stormwater runoff and flow in drainage channels. The potential impact on surface water will be the deterioration of water quality, which in turn will have health implications to aquatic ecology and downstream water users.

→ Increase in surface water flow due to the loss of vegetation cover and soil compaction

During the construction and operational phases, there is potential for an increase in runoff due to the loss of vegetative cover, increased impervious areas associated with infrastructure, and soil compaction. The additional runoff has the potential to increase stormwater peak flows in drainage lines and their receiving water courses.

SIGNIFICANCE SCREENING

The significance screening of the above mentioned impacts is outlined in **Table 7-8**.

Table 7-8: Impact Significance Screening for Potential Surface Water Impacts

IMPACT	PHASE	CHARACTER	PROBABILITY	CONSEQUENCE	SIGNIFICANCE
Surface water contamination	C, O, D	Negative	1	1	Very Low
Increase in surface water flow due to the loss of vegetation cover and soil compaction	C, O, D	Negative	2	1	Very Low

POTENTIAL MITIGATION MEASURES

The following potential mitigation measures have been identified:

- Due to the potential for soil compaction due to vehicles, traffic must be limited to existing or proposed roadways as far as possible.
- The construction of roads must be limited in width and length as far as is practical to limit impacts.
- Where soil compaction outside of the designated development areas occurs, this needs to be rehabilitated to the pre-development soil permeability to maintain infiltration.
- Vegetation removal must be kept to a minimum and limited to the area of development.
- Where an impact to the vegetation outside of the development footprint occurs, rehabilitation measures must be undertaken to maintain the baseline vegetation population and health.
- Spills must be appropriately managed on site.
- Machinery must be regularly checked to ensure hydrocarbon leaks (including fuel and hydraulic fluids) are not occurring.
- Drip trays must be used where necessary.
- The filling of vehicles must be undertaken in a designated area where spills can be contained.
- Fuels and oils must be stored within bunded areas.
- Parking areas for staff vehicles should ideally be placed on hardstanding (e.g. asphalt) to limit the impacts of oil leaks to the soil environment.
- On-site ablutions must be made available during site construction and decommissioning.

FURTHER STUDIES RECOMMENDED IN THE EIA PHASE

No further studies are recommended.

7.10 GROUNDWATER

SENSITIVE AREAS

No sensitive areas were identified in terms of ground water during the scoping phase.

IMPACT IDENTIFICATION

- **Groundwater contamination associated with the spill or loss of containment of chemicals**

During the construction phases there is potential for soil contamination associated with potential releases of environmental contaminants and hazardous substances (typically sewage / portable toilet chemicals, cement, oil, grease, and fuel).

Product and raw material transport will be required and it has been assumed that vehicle maintenance and refuelling may be undertaken on-site. Therefore, hydrocarbon contamination from fuel storage tanks, fuel distribution and oil handling facilities is considered potential groundwater risk.

The above contaminants will not be stored and handled in large / bulk quantities; the associated severity of potential releases to the environment is likely to be small. However the cumulative release of contaminants over prolonged periods may result pose a greater risk to the environment.

The above contaminants have the potential to be transported into the groundwater through a process of percolation. The potential impact on ground water will be the deterioration if water quality within the aquifer.

SIGNIFICANCE SCREENING

The significance screening of the above mentioned impacts is outlined in **Table 7-9**.

Table 7-9: Impact Significance Screening for Potential Ground Water Impacts

IMPACT	PHASE	CHARACTER	PROBABILITY	CONSEQUENCE	SIGNIFICANCE
Groundwater contamination associated with the spill or loss of containment of chemicals	C, O, D	Negative	2	1	Very Low

POTENTIAL MITIGATION MEASURES

The following potential mitigation measures have been identified:

- Chemicals, hydrocarbon materials and hazardous substances maintained onsite must be managed in accordance with the Hazardous Substances Act (No. 15 of 1973) and its relevant regulations.
- Indicate the location of the fuel and chemical storage area on the layout plans.
- Keep fuels, oils or other chemicals used outside of the bunded area to a minimum and use suitable secondary containment in the form of drip trays.
- Spills must be appropriately managed on site.
- Machinery must be regularly checked to ensure hydrocarbon leaks (including fuel and hydraulic fluids) are not occurring.
- Drip trays must be used where necessary.
- The filling of vehicles must be undertaken in a designated area where spills can be contained.

FURTHER STUDIES RECOMMENDED IN THE EIA PHASE

No further studies are recommended.

7.11 HERITAGE

SENSITIVE AREAS

The sensitive heritage areas in and around Enamandla PV 5 are shown in pink on **Figure 7-2**. The sensitive areas, mainly rocky outcrops, were identified from Google Earth and may not be a true

reflection of the heritage sensitivities of the project area; these will be confirmed during the detailed EIA investigations.

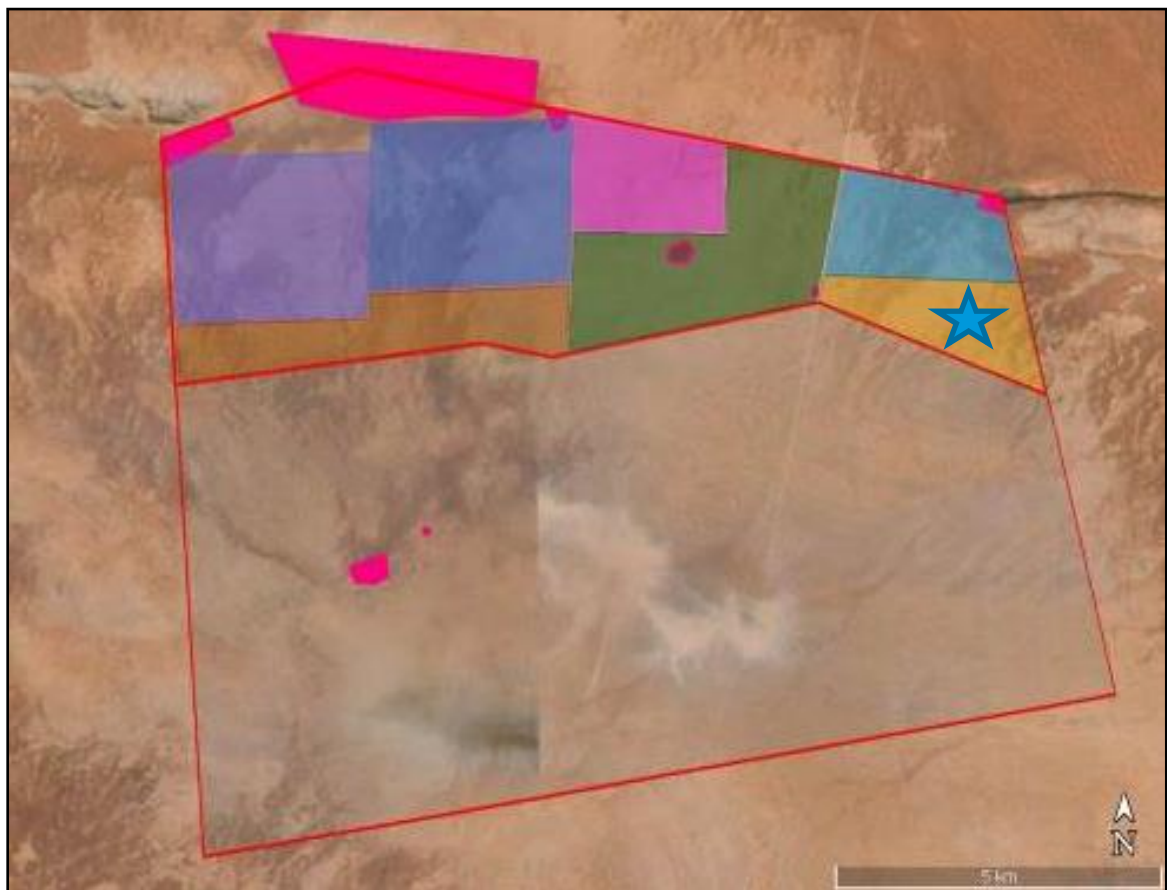

Figure 7-2: Heritage Sensitive Areas (shown in Pink) in relation to the Enamandla PV 5 (Blue Star)

IMPACT IDENTIFICATION

→ Physical disturbance of archaeological sites

The construction and decommissioning of infrastructure including PV panels, internal access roads, fencing, etc. will result in direct impacts to the landscape and any potential heritage that lies on it.

The main impacts resulting from the operational phase are potential vandalism of heritage sites by staff of the solar facility. This includes stripping of fittings from abandoned farm buildings, careless damage to kraal walls, graffiti on rock art sites, etc.

The main cause of impacts to archaeological sites is direct, physical disturbance of the material itself and its context. The heritage and scientific potential of an archaeological site is highly dependent on its geological and spatial context. It is not anticipated that there will be any impacts to the Built Environment. Historic structures and graveyards are sensitive to physical damage such as demolition as well as neglect. They are also context sensitive, in that changes to the surrounding landscape (i.e. visual impacts) will affect their significance.

SIGNIFICANCE SCREENING

The significance screening of the above mentioned impacts is outlined in **Table 7-10**.

Table 7-10: Impact Significance Screening for Potential Heritage Impacts

IMPACT	PHASE	CHARACTER	PROBABILITY	CONSEQUENCE	SIGNIFICANCE
Physical disturbance of archaeological sites	C, O, D	Negative	2	2	Low

POTENTIAL MITIGATION MEASURES

The following potential mitigation measures have been identified:

- Due to the fact that the subterranean presence of archaeological and/or historical sites, features or artefacts is always a distinct possibility, a “watching brief” should be developed.
- Construction activity should be restricted to the immediate footprint of the infrastructure.
- Areas of potential heritage sensitivities that are identified in the EIA phase, should be demarcated.

FURTHER STUDIES RECOMMENDED IN THE EIA PHASE

The EIA phase study will fulfil the requirements of heritage impact assessment as defined in section 38 of the NHRA. This means that the assessment has to cover the full range of potential heritage resources as defined in the National Heritage Resources Act 25 of 1999.

The aim of the EIA will be to identify and assess the significance of all heritage resources on the property, to assess the preferred and alternative options and to rate them in terms of significance, to determine the potential impacts on the heritage resources, and where appropriate to recommend “no-go” areas and to propose mitigation if avoidance is not possible. Refer to detailed plan of Study (Chapter 9).

7.12 PALAEOLOGY

SENSITIVE AREAS

A desktop palaeontological heritage assessment of the project area has been undertaken. No highly-sensitive palaeontological sites or no-go areas have been identified within the study area.

Notwithstanding the above, all South African fossil heritage is protected by law (South African Heritage Resources Act, 1999) and fossils may not be collected, damaged or disturbed without a permit from the relevant Provincial Heritage Resources Agency (in this case SAHRA).

IMPACT IDENTIFICATION

→ Physical disturbance of palaeontological sites

The construction phase will entail surface clearance as well as shallow excavations into the superficial sediment cover and underlying bedrock. The development may adversely affect potential fossil heritage within the study area by destroying, damaging, disturbing or permanently sealing-in fossils preserved at or beneath the surface of the ground that are then no longer available for scientific research or other public good.

Such impacts on fossil heritage are generally direct, negative and of permanent effect (non-reversible). The planning, operational and decommissioning phases of the solar energy facility are unlikely to involve further adverse impacts on local palaeontological heritage.

Impacts on unique or irreplaceable fossil heritage resources are improbable and their severity is anticipated to be negligible since (1) highly significant fossil sites are unlikely to be affected and (2) in many cases these impacts can be mitigated.

→ Cumulative impacts

Due to the fact that no highly-sensitive palaeontological sites or no-go areas were identified within the study area, the cumulative impacts inferred for the various alternative energy developments in the Aggeneys region of the Northern Cape are likewise assessed as very low.

SIGNIFICANCE SCREENING

The significance screening of the above mentioned impacts is outlined in **Table 7-11**.

Table 7-11: Impact Significance Screening for Potential Palaeontological Impacts

IMPACT	PHASE	CHARACTER	PROBABILITY	CONSEQUENCE	SIGNIFICANCE
Physical disturbance of palaeontological sites	C	Negative	1	1	Very Low
Cumulative impacts	C	Negative	1	1	Very Low

POTENTIAL MITIGATION MEASURES

Chance fossil finds should be safeguarded - preferably in situ - and reported by the ECO as soon as possible to SAHRA (Contact details: Mrs Colette Scheermeyer, P.O. Box 4637, Cape Town 8000. Tel: 021 462 4502. Email: cscheermeyer@sahra.org.za), so that appropriate mitigation (i.e. recording, sampling or collection) by a palaeontological specialist can be considered and implemented. The palaeontologist concerned with mitigation work would need a valid fossil collection permit from SAHRA and any material collected would have to be curated in an approved depository (e.g. museum or university collection) (SAHRA 2013). These recommendations should be incorporated into the Environmental Management Programme (EMPr) for the solar energy developments.

FURTHER STUDIES RECOMMENDED IN THE EIA PHASE

Pending the potential discovery of significant fossil remains (e.g. mammalian bones or teeth) during the construction phase, no further specialist palaeontological studies or mitigation are recommended.

7.13 VISUAL

SENSITIVE AREAS

Visual constraints or sensitive features have been mapped on **Figure 7-3**. The main scenic resources, ridgelines, steep slopes and key receptors are indicated.

→ Topographic Features:

- Prominent ridgelines in the landscape are visually sensitive and should be avoided. The study area is generally flat and the two ridgelines in close proximity to the study area (indicated on **Figure 7-3**) are not currently included in the development footprint.
- Gamsberg inselberg, which lies to the north-east of the study area, is a visually sensitive geological feature, which is prominent in the landscape. It is however well outside the current footprint area.

→ **Surrounding homesteads**

- The area around the study area is largely uninhabited; the only homesteads likely to be affected by the proposed development are indicated on the sensitivity map. The closest being Nombies, Struis-en-Bult, Brabees and Blomhoek.

→ **Towns/urban areas**

- The town of Aggeneys is situated ~19km from Enamandla PV 5 and may be affected by the proposed development, which may be visible from some locations on the outskirts of the town.
- The town of Pofadder is located approximately 56km from Enamandla PV 5 and will not be affected by the proposed development.

→ **Roads**

- The N14 national road is approximately 16km from Enamandla PV 5 and may be affected by the PV solar facility along stretches of the road.
- Loop 10 Road and other farm roads are low traffic, gravel roads. Loop 10 Road is about 8km from the study area at its closest point and the PV solar facility may be visible from portions of this road and from other farm roads in the area. The R358 is about 50km south-west of the study area and not likely to be affected in any way.

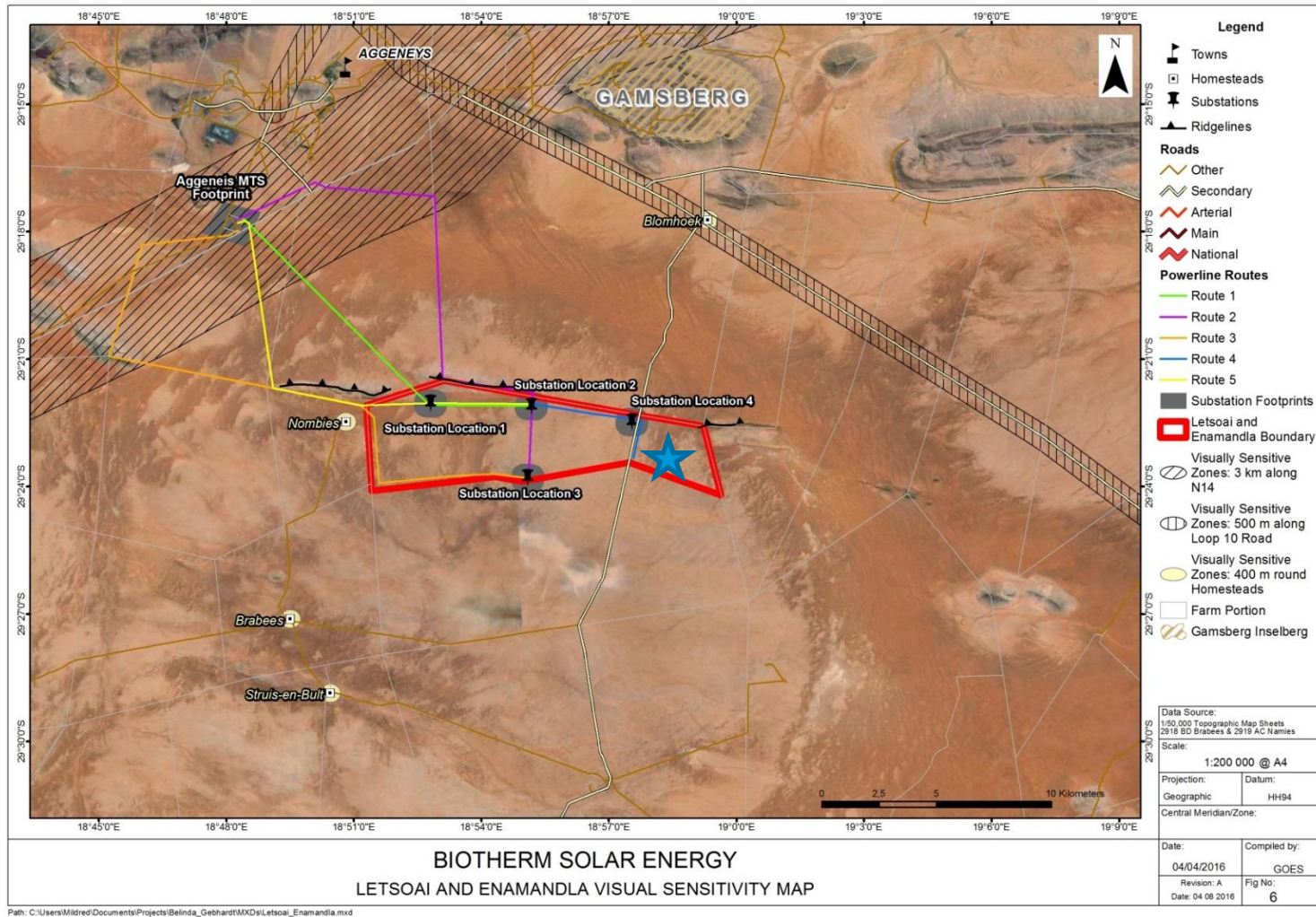

Figure 7-3: Visual Sensitive Areas in relation to the Enamandla PV 5 (Blue Star)

IMPACT IDENTIFICATION

Explanatory Note on Determination of Visual Impacts*

The distance of a viewer from an object is an important determinant of the visibility, sometimes referred to as the visual exposure. This is due to the visual impact of an object diminishing/attenuating as the distance between the viewer and the object increases. The Zone of Visual Influence (ZVI) is the maximum extent around an object, beyond which the visual impact will be insignificant, primarily due to distance.

Apparent size reduces linearly however, there is a large body of literature illustrating that visual *impact* reduces exponentially, rather than linearly. A recently published Scottish Guideline states; "It is important to emphasize, however, that visibility and distance do not follow a linear relationship." (Scottish Government, 2011). According to Hull and Bishop (1988) the visual impact can be said to decrease at an exponential rate and so at 1000m would, nominally, be 25% of the impact as viewed from 500m. At 2000m it would be 10% of the impact at 500m (Hull and Bishop 1988). More recent studies on viewing distance have built on these early estimations and all emphasise the role that elevation, the angle of the sun and landscape characteristics play in determining visibility over distance.

There are very few available guidelines on the appropriate ZVI (or suggested limit of analysis) for solar facilities but studies indicate that glare can cause an impact up to 6km away (usually from troughs at this distance) (Sullivan, 2012). PV panels are generally lower in height and reflect less brightly than CSP systems. Visibility also depends on landscape characteristics and how elevated the viewpoint is in relation to the facility.

The Northern Cape has no specified ZVI or guidelines for solar energy but based on the above and given the flat character of the landscape and the clear air in the area, the suggested limit of assessment appropriate for this study area is defined, for the purposes of this VIA, as follows⁴:

- less than 3km – PV solar facility and glare may be a prominent feature, dominating perception;
- between 3km and 6km – PV solar facility may dominate perception to some extent; and
- more than 6km – PV solar facility may be marginally visible, but the nearest objects generally would dominate perception.

Potential visual issues and impacts identified are described below. Not all of these can be classified as visual impacts, but are concerns and issues that should be considered.

→ **Visual impact during construction and decommissioning**

There will be some visual impacts on motorists and inhabitants during the construction and decommissioning periods resulting from laydown areas, construction vehicles, dust and equipment. These impacts will be transitory in nature for the duration of construction / decommissioning.

→ **Visual intrusion on the sense of place, including scenic landscapes**

The remote and rural character of the area, typical of the Northern Cape Karoo is flat with low vegetation and clear air, providing very little visual absorption. The strongly regular geometric

⁴ Once the height of the PV panels is established, these thresholds may change.

patterns and reflective surfaces of the panels and the power conversion units will differ from the current visual landscape and may impact the sense of place and scenic landscape.

→ **Visual impacts of PV panels and the power conversion units on inhabitants and motorists**

The low profile of the PV panels will reduce their impact when viewed at low elevations but glare and power conversion units may impact inhabitants and motorists. The area is however, sparsely populated, with few scattered homesteads. Nombies, Brabees, Struis-en-Bult and Blomhoek are situated with 20km radius and the town of Aggeneys is located approximately 12,5km away. Motorists/tourists on the N14 and Loop 10 Road may also be affected by the proposed development along stretches of these roads.

→ **Visual impacts of substation and O&M building on inhabitants and motorists**

The proposed substation has a maximum height of 35m-40m and together with other O&M facility may have visual impacts on inhabitants and motorists.

→ **Visual impact of security lighting**

Any lighting for security at the site may have a visual impact on the clear, dark skies of the area. Detailed information regarding lighting has not yet been specified and will be considered in the EIA phase.

→ **Cumulative visual impacts**

Many solar and wind energy projects are being proposed in the area, and include: Aggeneys PV (Solar Capital), Aggeneys PV (Biotherm) Khâi-Mai and Korana WEFs (Mainstream), Namies WEF(Juwi), Zuurwater Solar Facility (PV Africa) and Boesmanland Solar Farm. If these are all to be built the developments would significantly alter the visual landscape of this part of the Northern Cape.

SIGNIFICANCE SCREENING

The significance screening of the above mentioned impacts is outlined in **Table 7-12**.

Table 7-12: Impact Significance Screening for Potential Visual Impacts

IMPACT	PHASE	CHARACTER	PROBABILITY	CONSEQUENCE	SIGNIFICANCE
Visual impact during construction and decommissioning	C	Negative	2	1	Low
	D	Negative	1	2	Very Low
Visual intrusion on the sense of place, including scenic landscapes	O	Negative	2	2	Low
Visual impacts of PV panels and the power conversion units on inhabitants and motorists	O	Negative	2	2	Low
Visual impacts of substation and O&M building on inhabitants and motorists	O	Negative	2	2	Low
Visual impact of security lighting	C	Negative	2	2	Very Low
Cumulative visual impacts	O	Negative	3	2	Medium

POTENTIAL MITIGATION MEASURES

The following potential mitigation measures have been identified:

- Implement dust control measures at the site and on access roads during construction phase.
- Control for wind-blown litter.
- Rehabilitation and restoration of all disturbed areas.

FURTHER STUDIES RECOMMENDED IN THE EIA PHASE

The EIA Phase study will employ qualitative as well as quantitative techniques and criteria will be used in the evaluation and clearly documented to ensure the reliability and credibility of conclusions and recommendations. The study will comply with the Department of Environmental Affairs and Development Planning's Guideline for Involving Visual and Aesthetic Specialists in EIA Processes (2005). Refer to detailed plan of Study (**Chapter 9**).

7.14 TRAFFIC AND TRANSPORTATION

SENSITIVE AREAS

No sensitive traffic areas were identified during the scoping phase.

IMPACT IDENTIFICATION

→ Increased traffic generation around the study area by construction vehicles

The construction phase is expected to generate additional traffic volumes on the local road network due to the transport of raw materials and machinery to site. However, whilst there will be an increase in the traffic flow, it is expected that the road network can accommodate the increase due to the fact that very low traffic volumes are experienced on the N14 between Pofadder and Springbok.

→ Deterioration of the surrounding road network due to an increase of traffic around the site

Raw materials and machinery will be transported to the study area during the construction phase. It is expected that the bulk of the construction plant would remain on site during construction. The impact of the heavy vehicles on the surrounding roads is considered to be negligible.

The operational phase of the facility will require very little staff, for some inspection, maintenance and repair works. The traffic impact on the surrounding roads will therefore be negligible.

SIGNIFICANCE SCREENING

The significance screening of the above mentioned impacts is outlined in **Table 7-13**.

Table 7-13: Impact Significance Screening for Potential Traffic Impacts

IMPACT	PHASE	CHARACTER	PROBABILITY	CONSEQUENCE	SIGNIFICANCE
Increased traffic generation around the study area by construction vehicles	C, D	Negative	2	2	Low

IMPACT	PHASE	CHARACTER	PROBABILITY	CONSEQUENCE	SIGNIFICANCE
Deterioration of the surrounding road network due to an increase of traffic around the site	O	Negative	2	2	Low

POTENTIAL MITIGATION MEASURES

The following potential mitigation measures have been identified:

- The posted speed limit on the N14 in the vicinity of the proposed development is currently 120km/h. It is suggested that the speed limit should be reduced in advance of the intersection with the access road.
- Intersection warning signs should be erected either side of the access road in accordance with the requirements of the South African Road Traffic Signs Manual.
- Construction vehicles should only use the roads during daylight hours.
- All heavy vehicles should ensure that their headlights are on to increase their visibility to other vehicles and pedestrians.
- All drivers should comply with the relevant traffic laws and regulations

FURTHER STUDIES RECOMMENDED IN THE EIA PHASE

Due to the expected low trip generation (construction phase only & operational phase negligible), only a Traffic Impact Statement (TIS) will be required, as per the relevant National Standards, i.e. South African Committee of Transport Officials (COTO). Refer to detailed plan of study (**Chapter 9**).

7.15 SOCIAL ENVIRONMENT

SENSITIVE AREAS

A social sensitivity map for the proposed project should present those communities (or settlements) that may be significantly adversely affected by the proposed project. There are currently no inhabitants in the study area, or the immediately surrounding area, that would experience direct, adverse socio-economic impacts. The nearest community that may be affected by the project is Aggeneys, a distance of 14 km from the study area. The potential socio-economic impact of the proposed project will need to be assessed further during the SIA, following a review of other specialist studies. It was, therefore, not possible to develop a meaningful social sensitivity map during the scoping phase.

IMPACT IDENTIFICATION

→ Increase in employment and business opportunities

In the construction phase a labour force will be required. Some of the labour will be sourced from outside the Khâi-Ma Local Municipality due to the very limited local population and the lack of skills required for the construction (due to the specialised nature of some of the construction activities). The potential benefits in terms of short-term employment and skills development are therefore likely to be recognised on many levels, from local to national level.

In the operational phase the project is anticipated to provide a number of employment opportunities, from professional and management level through to skilled and unskilled levels. Professional and management level employment is likely to be sourced from outside the Northern Cape, due to the specialised nature of this development, while there is the potential

for skilled and unskilled employees (e.g. service providers, security and cleaners) to be sourced locally or from within the region. The impact of employment opportunities will be determined by the total number and breakdown (level) of operational phase opportunities that will be created by the proposed project.

The decommissioning phase may require a limited number of short-term unskilled or semi-skilled labour. This could potentially increase short term employment opportunities for local communities, as labour will be sourced locally as far as practically possible.

→ **Decrease in employment and business opportunities**

In the decommissioning phase there is also the potential for the loss of permanent employment opportunities following the decommissioning of the proposed project. The significance of this impact will be investigated further during the SIA.

→ **Increased economic development opportunities**

In the construction phase project has the potential generate LED opportunities. The nearest town of Aggeneys could provide services such as accommodation and cleaning services, stimulating economic development within the local area. Other local towns that could also be positively impacted include Pofadder and Springbok. Larger-scale manufacturing and specialised services for the proposed project are likely to be sourced from a regional and national level. The proposed project is, therefore, likely to impact all levels of the economy from local to national to differing degrees and scales.

In the operational phase the project has the potential to result in economic development opportunities during the operational phase. As local resources are limited, the majority of specialised services are likely to be sourced from regional or national service providers, resulting in economic development opportunities in the relevant sectors, including solar power generation equipment and associated infrastructure suppliers. There are, however, a number of potential local economic development opportunities. Despite the constraints placed on local communities by restricted access to natural and economic resources, local residents could potentially provide services (e.g. catering, transport and accommodation) and manufacturing amenities to the proposed project during the operational phase. The extent of local, regional and national economic development resulting from the proposed project will be considered further during the SIA.

→ **Nuisance from noise, dust and traffic disturbances**

The construction and decommissioning phases of the proposed project may result in a number of localised disturbances that may indirectly affect local activities, such as farming (on neighbouring sites) and tourism (passing through the area). These may include the generation of dust, noise and traffic associated with the construction activities. The closest community is located 9 km north of the N14 Highway, and therefore between 4 km and 14 km from the proposed project and infrastructure. The impacts of the construction activities may, therefore, affect this community where activities through increased traffic and activities in the local area. There are no other known sensitive receptors, such as tourism establishments or farming communities within close proximity to the study area.

→ **Change in sense of place**

The sense of place is a social construct of individuals and communities and their interaction within the landscape in which they live and work, creating a unique identity for a geographical area. The study area is located within a predominantly flat, desert landscape, with a sparse, scattered population and limited agricultural and mining activities.

The change in the nature of the study area as a result of the construction activities, as well as presence of construction staff, is likely to change the local sense of place. This local change is likely to have a direct impact on the closest town of Aggeneys through economic development and an increase in population. The other settlements within the local area (namely, Pofadder) may be affected indirectly.

The operation of the proposed project is likely to change in the overall nature of the area, specifically related to the development of infrastructure such as CSP towers. A change in the sense of place has the potential to affect the surrounding communities; however this is limited to Aggeneys. Other potential sensitive receptors (such as tourism operators and tourist travelling through the area) will need to be investigated further during the SIA phase.

→ **Disturbances to local communities due to migrant labour**

The construction phase may lead to the influx of skilled and unskilled employment seekers from outside the immediate area. This could lead to social conflict over the resources and employment opportunities. The potential for this is, however, likely to be limited, due to the isolated nature of the study area, and the lack of supporting services and infrastructure within the local area. Labour will be sourced from surrounding areas and towns as far as practically possible. Should labour be sourced for outside the local municipality, this could result in a number of local short-and long-term localised social issues, such as increased prostitution, and drug and alcohol abuse. Details on the number of construction phase employees, as well as temporary housing and services provision, will need to be investigated further during the SIA.

→ **Increase in communicable diseases and reduced public health**

In the construction phase a presence of an outside labour force within a small community could potentially negatively affect local public health, due to a higher likelihood of a spread of communicable diseases such as Tuberculosis, as well as HIV/AIDS and other sexually transmitted diseases. HIV/AIDS is known to be a significant issue within the Northern Cape (Department of Health, 2012). Further details on the proposed sourcing and management of construction phase employees will need to be interrogated during the SIA.

→ **Loss of farmland and associated economic implications**

The activities associated with the construction, operational and decommissioning phases may preclude the use of the site for other purposes. This may reduce the available land for grazing in the local area with associated long term economic impacts on the land owner. The offset of leasing or selling the site against this loss of agricultural land will be assessed further during the SIA phase.

→ **Loss of access to natural resources**

The activities associated with the construction, operational and decommissioning phases may preclude the use of the site for other purposes. Communities within the local area are known to collect wood and medicinal plants from the open farming and accessible mine land surrounding Aggeneys for personal use and selling to the local communities (ERM, 2013). Certain areas of the proposed project may fall within the areas regularly accessed by the community. The use of the study area by local communities, however, is to be assessed further within the SIA.

→ **Access to water resources**

The operational phase of the proposed project could result in additional pressure on available water resources. Currently BMM owns and operates the Pelladri Water Board which provides households, in Pella, Pofadder and Aggeneys, with water drawn from the Orange River (ERM, 2013). There is, however, currently restricted water for the existing users; therefore the

additional pressure on available water resources could result in a negative impact on existing users.

→ **Cumulative development effects on local economic development opportunities**

Currently Black Mountain Mine is the principle employer within the local municipality, pinning mining as the key local economic driver. One PV facility and two CSP (trough) facilities have been constructed in the study area, and one additional PV facility has been awarded preferred bidder status. There are no other significant economic activities within the local area, with agricultural, tourism and social services sectors currently providing the main source of (limited) employment in the local economy.

The construction and operation of a number of solar and wind projects within the area between Springbok and Pofadder will contribute collectively towards a significant increase in local employment and business development opportunities within the local municipality. The provision of services by existing local communities, and the development of new opportunities through the presence of new residents (temporary and permanent) during construction and operational phases could present numerous economic development opportunities through services such as accommodation, transport provision, catering, and cleaning services.

→ **Cumulative development effects on local service provision**

The lack of access to water within this arid area has meant that communities are widely spread and resident populations are small. Infrastructure is also limited to the National Highway (N14), and basic municipal services with the towns. The development of numerous renewable energy projects within the 100 km radius is likely to put significant pressure on the local municipalities and communities. The proposed project is one of eight proposed solar energy facility within the local area, and could potentially contribute towards this pressure.

There is, however, also an opportunity for these developments to assist the local municipalities by supplying services and infrastructure to local communities in addition to the proposed projects. Further assessment of the nature of these opportunities and constraints and the potential impacts will be undertaken in the SIA.

→ **Cumulative development effects on tourism activities**

The tourism industry within the local area may be affected by this change in landscape and sense of place as a result of the construction and operation of several large solar and mining operations within the local area. Tourism in this region relies in part on the aesthetic value of the Karoo landscape, as well as the “picturesque” nature of the small Karoo towns. There is, however, an opportunity in terms of promoting solar facilities as technology tourism within the region. The SIA will further consider the potential cumulative impact on tourism.

→ **Cumulative development effects on employment patterns**

With the development of a number of solar facilities within the local area, there is potential for the broad change in nature of businesses and employment patterns within the local area. The potential economic investment, business development in the area, and an overall awareness of different types of employment opportunities could result in people changing employment sectors.

Currently local employment is predominantly in mining and agriculture-based sectors. There is a potential for this to shift towards construction and services sector employment as new opportunities could be perceived as more favourable to existing opportunities. The new opportunities are likely to be short to medium term opportunities (e.g. construction phase only). The impact could, however, be long-term in that loss of staff for existing employers could result in loss of revenue, closure, or the need to source new staff. This could result in a higher

unemployment rate following the completion of construction projects, as current staff would not be able to return to their original employer, and increased competition for employment.

→ Cumulative development effects on access to water resources

There are numerous proposed renewable energy projects, as well as a new mining operation within the local area (Gamsberg Mine). There is currently a shortage of water for existing residents and activities in the area. Should all of the proposed renewable energy project be authorised and constructed, there is unlikely to be sufficient water available to support all of these projects, and to sustain the existing agricultural activities established along, and highly dependent on, the Orange River. The cumulative impact on water resources is therefore a key concern in relation to the local socio-economic environment.

SIGNIFICANCE SCREENING

Table 7-14: Impact Significance Screening for Potential Social Impacts

IMPACT	PHASE	CHARACTER	PROBABILITY	CONSEQUENCE	SIGNIFICANCE
Increase in employment and business opportunities	C, O, D	Positive	3	2	Medium
Decrease in employment and business opportunities	D	Negative	3	3	Medium
Nuisance from noise, dust and traffic disturbances	C	Negative	1	2	Very Low
	D	Negative	1	1	Very Low
Change in sense of place	C	Negative	1	1	Very Low
	O	Negative	3	2	Medium
Disturbances to local communities due to migrant labour	C	Negative	2	1	Very Low
Increase in communicable diseases and reduced public health	C	Negative	2	1	Very Low
Loss of farmland and associated economic implications	C		2	2	Low
Loss of access to natural resources	C	Negative	2	2	Low
Access to water resources	O	Negative	3	3	Medium
Cumulative development effects on local economic development opportunities	C, O	Positive	3	3	Medium
Cumulative development effects on local service provision	C, O	Negative ⁵	TBD*	TBD	TBD
	C, O	Positive ⁶	TBD	TBD	TBD
Cumulative development effects on tourism activities	C, O	Negative ⁷	TBD	TBD	TBD
	C, O	Positive ⁸	TBD	TBD	TBD
Cumulative development effects on employment patterns	C, O	Negative	TBD	TBD	TBD

⁵ Pressure on the local municipalities and communities

⁶ Assistance to the local municipalities by supplying services and infrastructure to local communities

⁷ Aesthetic value of the Karoo landscape, as well as the "picturesque" nature of the small Karoo towns

⁸ Promoting solar facilities as technology tourism within the region

IMPACT	PHASE	CHARACTER	PROBABILITY	CONSEQUENCE	SIGNIFICANCE
Cumulative development effects on access to water resources	O	Negative	2	4	Medium

* *To be determined*

POTENTIAL MITIGATION MEASURES

The following potential mitigation measures have been identified:

- Ensuring local communities (through formal channels such as ward councillors and Department of Labour) are made aware of the potential opportunities available during construction in order for expectations to be managed appropriately.
- Prioritisation of local labour through implementing contractor policies.
- Ensuring that labour and staff brought into the area (by contractors or the developer) can be accommodated within existing or proposed formal housing, through discussions with the Housing and other relevant social services divisions at the local municipality.
- Undertake a survey of industries and businesses in the local area to identify potential suppliers.
- The developer and contractors must make HIV/AIDS awareness and prevention program development and implementation a condition of contract for all suppliers and sub-contractors.

FURTHER STUDIES RECOMMENDED IN THE EIA PHASE

There were no significant socio-economic impacts identified during the socio-economic screening study, and there is sufficient information available for the proposed project site and study area. It is therefore proposed that a desktop SIA is undertaken during the EIA phase for the proposed project.

The desktop assessment will include a review of the information contained within other specialist studies, as well as insights from the scoping phase stakeholder engagement process. This process will allow for the assessment of key socio-economic issues relating to the proposed project. Refer to detailed plan of Study (**Chapter 9**).

8

CONCLUSIONS AND RECOMMENDATIONS

The essence of any S&EIR process is aimed at ensuring informed decision-making and environmental accountability, and to assist in achieving environmentally sound and sustainable development. In terms of NEMA, the commitment to sustainable development is evident in the provision that “development must be socially, environmentally and economically sustainable... and requires the consideration of all relevant factors...”. NEMA also imposes a duty of care, which places a positive obligation on any person who has caused, is causing, or is likely to cause damage to the environment to take reasonable steps to prevent such damage. In terms of NEMA’s preventative principle, potentially negative impacts on the environment and on people’s environmental rights (in terms of the Constitution of the Republic of South Africa, Act No. 108 of 1996) should be anticipated and prevented, and where they cannot be altogether prevented, they must be minimised and remedied in terms of “reasonable measures”.

In assessing the environmental feasibility of Enamandla PV 5, the requirements of all relevant legislation have been considered. This relevant legislation has informed the identification of potential impacts associated with the proposed project.

Figure 8-1 illustrates the sensitivity map for Enamandla PV 5.

A summary of the potential impacts associated with the project, preliminary significance ratings, and requirements for EIA Phase specialist studies is provided in **Table 8-1**.

Table 8-1: Summary of Scoping Phase Impact Assessment Process

ENVIRONMENTAL RECEPTOR	IMPACT	PHASE	CHARACTER	SIGNIFICANCE	FATAL FLAW (YES/NO)	MITIGATION REQUIRED (YES/NO)	EIA PHASE STUDY REQUIRED (YES/NO)
Topography	Change in the site micro-topography	C, O	Negative	Very Low	No	No	No
	Change in study area macro-topography	C, O	Negative	Very Low	No	No	
Geology	Disturbance to underlying geology	C	Negative	Very Low	No	Yes	No
Climate	Climatic impacts such as greenhouse effect and perceived global warming, as well as the phenomenon of acid rain.	C / O	Negative	Very Low	No	Yes	No
	Contribution of cleaner energy to the National Grid	O	Positive	High	No	Yes	
Soils and Land Capability	Reduction in land available for grazing animals	C / O / D	Negative	High	No	Yes	Yes
	Soil erosion resulting in degradation of soil structure	C	Negative	Low	No	Yes	
		O / D	Negative	Very Low	No	Yes	
	Degradation of soil due to contamination	C	Negative	Low	No	Yes	
O / D		Negative	Very Low	No	Yes		
Natural Vegetation and Animal Life	Disturbance, loss and transformation of vegetation	C	Negative	Medium	No	Yes	Yes
	Impacts on fauna	C	Negative	Medium	No	Yes	
		O / D	Negative	Low	No	Yes	
	Proliferation of alien invasive plant species	C	Negative	Very Low	No	Yes	
		O / D	Negative	Low	No	Yes	
	Impacts on Broad-Scale Ecological Processes and Loss of Landscape Connectivity	O	Negative	Medium	No	Yes	
Reduced ability to meet conservation obligations & targets	O	Negative	Medium	No	Yes		
Avifauna	Temporary displacement of avifauna due to construction, operation and decommissioning of the solar plant and associated infrastructure	C, O, D	Negative	Medium	No	Yes	Yes
	Permanent displacement of avifauna due to habitat transformation	O	Negative	High	No	Yes	

ENVIRONMENTAL RECEPTOR	IMPACT	PHASE	CHARACTER	SIGNIFICANCE	FATAL FLAW (YES/NO)	MITIGATION REQUIRED (YES/NO)	EIA PHASE STUDY REQUIRED (YES/NO)
	Collisions with the solar infrastructure (i.e. PV panels)	O	Negative	Low	No	Yes	
Surface Water	Surface water contamination	C, O, D	Negative	Very Low	No	Yes	No
	Increase in surface water flow due to the loss of vegetation cover and soil compaction	C, O, D	Negative	Very Low	No	Yes	
Groundwater	Groundwater contamination associated with the spill or loss of containment of chemicals	C, O, D	Negative	Very Low	No	Yes	No
Heritage	Physical disturbance of archaeological sites	C, O, D	Negative	Low	No	Yes	Yes
Palaeontology	Physical disturbance of palaeontological sites	C	Negative	Very Low	No	Yes	No
	Cumulative impacts	C	Negative	Very Low	No	Yes	
Visual	Visual impact during construction and decommissioning	C	Negative	Low	No	Yes	Yes
		D	Negative	Very Low	No	Yes	
	Visual intrusion on the sense of place, including scenic landscapes	O	Negative	Low	No	Yes	
	Visual impacts of PV panels and the power conversion units on inhabitants and motorists	O	Negative	Low	No	Yes	
	Visual impacts of substation and O&M building on inhabitants and motorists	O	Negative	Low	No	Yes	
	Visual impact of security lighting	C	Negative	Very Low	No	Yes	
	Cumulative visual impacts	O	Negative	Medium	No	Yes	
Traffic	Increased traffic generation around the study area by construction vehicles	C, D	Negative	Low	No	Yes	Yes
	Deterioration of the surrounding road network due to an increase of traffic around the site	O	Negative	Low	No	Yes	
Socio-economic	Increase in employment and business opportunities	C, O, D	Positive	Medium	No	Yes	Yes
	Decrease in employment and business opportunities	D	Negative	Medium	No	Yes	
	Nuisance from noise, dust and traffic disturbances	C	Negative	Very Low	No	Yes	
		D	Negative	Very Low	No	Yes	

ENVIRONMENTAL RECEPTOR	IMPACT	PHASE	CHARACTER	SIGNIFICANCE	FATAL FLAW (YES/NO)	MITIGATION REQUIRED (YES/NO)	EIA PHASE STUDY REQUIRED (YES/NO)
	Change in sense of place	C	Negative	Very Low	No	Yes	
		O	Negative	Medium	No	Yes	
	Disturbances to local communities due to migrant labour	C	Negative	Very Low	No	Yes	
	Increase in communicable diseases and reduced public health	C	Negative	Very Low	No	Yes	
	Loss of farmland and associated economic implications	C		Low	No	Yes	
	Loss of access to natural resources	C	Negative	Low	No	Yes	
	Access to water resources	O	Negative	Medium	No	Yes	
	Cumulative development effects on local economic development opportunities	C, O	Positive	Medium	No	Yes	
	Cumulative development effects on local service provision	C, O	Negative ⁹	TBD	No	Yes	
		C, O	Positive ¹⁰	TBD	No	Yes	
	Cumulative development effects on tourism activities	C, O	Negative ¹¹	TBD	No	Yes	
		C, O	Positive ¹²	TBD	No	Yes	
	Cumulative development effects on employment patterns	C, O	Negative	TBD	No	Yes	
	Cumulative development effects on access to water resources	O	Negative	Medium	No	Yes	

⁹ Pressure on the local municipalities and communities

¹⁰ Assistance to the local municipalities by supplying services and infrastructure to local communities

¹¹ Aesthetic value of the Karoo landscape, as well as the “picturesque” nature of the small Karoo towns

¹² Promoting solar facilities as technology tourism within the region

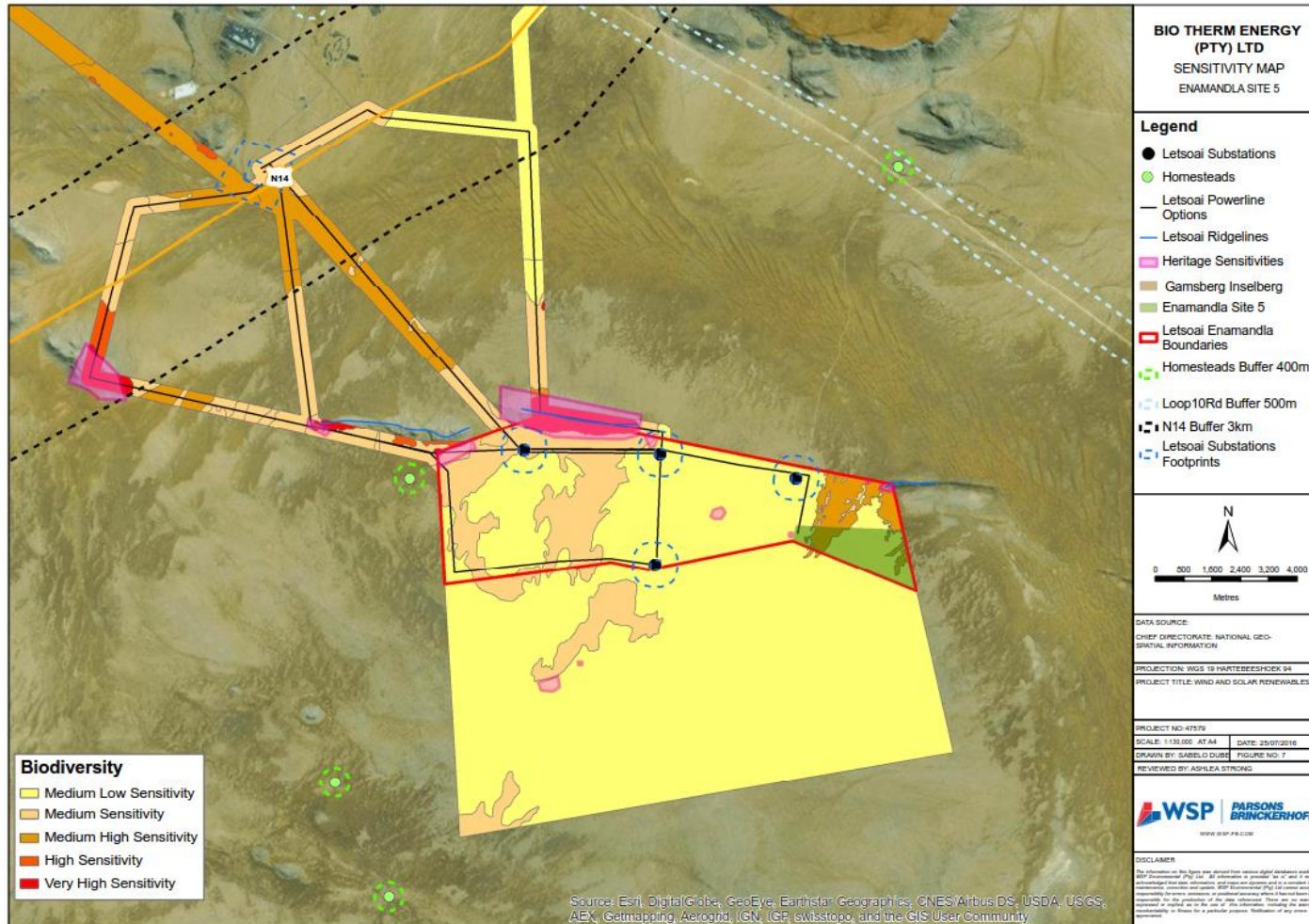

Figure 8-1: Sensitivity Map for Enamandla PV 5

9 PLAN OF STUDY FOR THE ENVIRONMENTAL IMPACT REPORTING PHASE

9.1 TERMS OF REFERENCE

Table 9-1 outlines the structure of the plan of as required in terms of Annexure 2 of GNR 982.

Table 9-1: Plan of Study Structure

PLAN OF STUDY CHAPTER	INFORMATION REQUIREMENT AS PER GNR 982
Alternatives	A description of the alternatives to be considered and assessed within the preferred site, including the option of not proceeding with the activity.
Description of EIA Tasks	A description of the tasks that will be undertaken as part of the environmental impact assessment process.
Aspects to be Assessed in the EIA Process	A description of the aspects to be assessed as part of the environmental impact assessment process.
Specialist Studies	Aspects to be assessed by specialists.
Impact Assessment Methodology	A description of the proposed method of assessing the environmental aspects, including a description of the proposed method of assessing the environmental aspects including aspects to be assessed by specialists.
	A description of the proposed method of assessing duration and significance.
Environmental Impact Report	Contents of EIR as specified in GNR 982 Annex 2
Stakeholder and Authority Engagement	An indication of the stages at which the competent authority will be consulted.
	Particulars of the public participation process that will be conducted during the environmental impact assessment process.
Progression of authorisations, permits and other development approvals	N/A

The following information required in terms of Annexure 2 of GNR 982 is not provided in this Plan of Study. Reference should be made to the relevant chapter within the scoping report:

- Identify suitable measures to avoid, reverse, mitigate or manage identified impacts and to determine the extent of the residual risks that need to be managed and monitored, including the option of not proceeding with the activity;

9.2 ALTERNATIVES

The scoping report identified and evaluated the feasibility of a range of site and technology options (**Table 9-2**). The following chapter summarises the scoping phase alternative assessment, and provides rationale for alternatives to be further considered and assessed in the EIA phase.

Table 9-2: Alternatives Summary

ALTERNATIVE CATEGORY	ALTERNATIVE IDENTIFIED IN SCOPING	ASSESSMENT IN EIA PHASE (YES/NO)
Alternative Locations	Alternative development regions i.e. falling outside the Springbok Wind REDZ	No
	Alternative development sites i.e. within the Springbok Wind REDZ study area	No
	Enamandla PV 5 Site – Alternative 1	Yes
	Enamandla PV 5 Site – Alternative 2 (Post Scoping)	Yes
Technology Alternatives	PV Technology	Yes
	CSP Technology	No
Layout and Design Alternatives	None identified	Yes
Access Road Alternatives	Widening of existing access road	Yes
	New access road	Yes
Internal Access Road Alternatives	None identified	Yes
Internal 132kv Powerline Route Alternatives	None identified	Yes
Tower Structure Alternatives	Steel / concrete monopole single circuit structure	Yes
	Steel / concrete monopole double circuit structure	Yes
	H-pole structure	Yes

LOCATION ALTERNATIVES

The following location alternatives were considered:

- Alternative development regions i.e. falling outside the Springbok Wind REDZ
- Alternative development sites i.e. within the Springbok Wind REDZ study area

The project development area was initially selected (prior to scoping) based a comprehensive assessment of environmental, solar resource, and grid / connectivity related criteria. This selection process ensured that the best practical / technically suitable environmental site option was selected. The scoping process subsequently provided a detailed assessment of the baseline environmental conditions on the site and the presence of potential environmental issues including the presence of fatal flaws.

The above process has determined that the project location is considered highly suitable in terms of reserve and grid / connectivity, as well as being located within the renewable energy hub that is developing in the Aggeneys Area. The scoping report revealed no significant environmental issues or fatal flaws.

As a result of the decision to only develop central tower technology in terms of the Letsoai CSP projects, the PV site delineations were revisited resulting in the identification of a second alternative

for Enamandla PV 5. Further work in terms of identifying and assessing alternative sites cannot be rationalised. The scope of the EIA phase is therefore proposed to include 2 alternatives for the Enamandla PV 5 site.

TECHNOLOGY ALTERNATIVES

Biotherm is proposing a combination of solar PV and CSP projects on the broader Enamandla and Letsoai development sites respectively. The rationale for diversified solar technology i.e. the implementation of both PV and CSP is due to the solar resource, high GHI for PV and high DNI for CSP, at the project site. Both technologies exhibit their own advantages i.e. PV technology produces energy and supplies electricity to the grid during sunshine hours, whilst CSP technology (with thermal energy storage) allows for flexible energy dispatch to the grid to serve high-tariff peak loads that occur outside daylight hours during late afternoon and early evening. Biotherm's development concept for Enamandla PV 5 is fundamentally predicated on PV technology.

Based on the above, the scope of the EIA phase is therefore proposed to be limited to the PV technology.

LAYOUT AND DESIGN ALTERNATIVES

No layout or design alternatives were available for assessment during scoping. The scoping phase did not identify potentially environmentally sensitive areas within the site which should be avoided by the proposed development.

During the EIA further detailed studies will however be undertaken in order to identify areas of sensitivity on or near the site. This information will be used to inform the layout and design alternatives for the project.

ACCESS ROAD ALTERNATIVES

Appropriate access roads will be constructed to link Enamandla PV 5 to the existing road network. At this stage two potential alternatives exist:

- Alternative 1 - An existing road connects the N14 to the project area. This road may require widening to ensure that it is suitable for use. At this stage it is proposed that the road will remain unsurfaced.
- Alternative 2 – Access to Enamandla PV 5 could potentially be obtained via a new 9.5 km road with a direct access off the N14; however, due to the fact that the N14 is a National Route, an access application to the South African National Roads Agency Limited (SANRAL) and/or the Northern Cape Province will be required.

During the EIA further detailed studies will be undertaken in order to identify sensitivity associated with each access road option. This information will be used to inform the impact assessment and the choice of the preferred option.

INTERNAL ROAD ALTERNATIVES

No alternative internal access routes were identified during scoping. During the EIA further detailed studies will be undertaken in order to identify areas of sensitivity on or near the site. This information will be used to inform the layout of the internal roads.

POWERLINE ALTERNATIVES

INTERNAL 132KV POWERLINE ALTERNATIVES

The power generated by the steam turbine(s) will be evacuated via 132kV overhead powerlines to the onsite substation. During the EIA further detailed studies will be undertaken in order to identify areas of sensitivity on or near the site. This information will be used to inform the layout of the internal powerlines.

TOWER STRUCTURE ALTERNATIVES

Three alternative 132kV tower structure alternatives were identified in scoping namely, 1) steel / concrete monopole single circuit structure; 2) steel / concrete monopole double circuit structure; and 3) H-pole structure. These alternatives will be considered further in the EIA Phase.

400KV POWER EVACUATION POWERLINE ALTERNATIVES

Alternative powerline corridors have been identified however; they are being assessed in a separated S&EIR process and will therefore not be included in the scope of this assessment.

THE “DO NOTHING” ALTERNATIVE

The no-go option is a feasible option; however, this would prevent BioTherm from contributing to the significant environmental, social and economic benefits associated with the development of the renewables sector. The no-go option is not the preferred option; however this will be assessed for comparative purposes in the EIA phase.

9.3 ASPECTS TO BE ASSESSED IN THE EIA PROCESS

Table 9-3 outlines the key aspects that were identified in the scoping phase; these aspects will be the subject for further assessment in the EIA Phase.

Table 9-3: Summary of aspects to be addressed in the EIA Phase

ENVIRONMENTAL RECEPTOR	ASPECT
Topography	Change in the site micro-topography
	Change in study area macro-topography
Geology	Disturbance to underlying geology
Climate	Climatic impacts such as greenhouse effect and perceived global warming, as well as the phenomenon of acid rain.
	Contribution of cleaner energy to the National Grid
Soils and Land Capability	Reduction in land available for grazing animals
	Soil erosion resulting in degradation of soil structure
	Degradation of soil due to contamination
Natural Vegetation and Animal Life	Disturbance, loss and transformation of vegetation
	Impacts on fauna
	Proliferation of alien invasive plant species

ENVIRONMENTAL RECEPTOR	ASPECT
	Impacts on Broad-Scale Ecological Processes and Loss of Landscape Connectivity Reduced ability to meet conservation obligations & targets
Avifauna	Temporary displacement of avifauna due to construction, operation and decommissioning of the solar plant and associated infrastructure Permanent displacement of avifauna due to habitat transformation Collisions with the solar infrastructure (i.e. PV panels)
Surface Water	Surface water contamination Increase in surface water flow due to the loss of vegetation cover and soil compaction
Groundwater	Groundwater contamination associated with the spill or loss of containment of chemicals
Heritage	Physical disturbance of archaeological sites
Palaeontology	Physical disturbance of palaeontological sites Cumulative impacts
Visual	Visual impact during construction and decommissioning Visual intrusion on the sense of place, including scenic landscapes Visual impacts of PV panels and the power conversion units on inhabitants and motorists Visual impacts of substation and O&M building on inhabitants and motorists Visual impact of security lighting Cumulative visual impacts
Traffic	Increased traffic generation around the study area by construction vehicles Deterioration of the surrounding road network due to an increase of traffic around the site
Socio-economic	Increase in employment and business opportunities Decrease in employment and business opportunities Nuisance from noise, dust and traffic disturbances Change in sense of place Disturbances to local communities due to migrant labour Increase in communicable diseases and reduced public health Loss of farmland and associated economic implications Loss of access to natural resources Access to water resources Cumulative development effects on local economic development opportunities Cumulative development effects on local service provision Cumulative development effects on tourism activities

ENVIRONMENTAL RECEPTOR	ASPECT
	Cumulative development effects on employment patterns

9.4 DESCRIPTION OF EIA TASKS

The EIA phase will consist of the following tasks; each of these tasks is detailed separately in the following sub-sections:

- Specialist studies
- Continuation of Authority and stakeholder engagement
- Assessment of the significance of potential impacts
- Preparation of the EIR

9.5 SPECIALIST STUDIES

Table 9-4 provides a list of the Specialists that will be involved in the detailed studies required for this project during the EIA Phase and their areas of expertise.

Table 9-4: Details of the Specialist Consultants

SPECIALIST FIELD	COMPANY NAME	TEAM MEMBERS
Soil and Land Capability	WSP Environmental (Pty) Ltd	Bruce Wickham, Gerg Matthews
Biodiversity	Simon Todd Consulting	Simon Todd
Avifauna	Chris van Rooyen Consulting	Chris van Rooyen, Albert Froneman
Heritage	ACO Associates	Tim Hart, Lita Webley, David Halkett
Visual	-	Belinda Gebhardt
Social	WSP Environmental (Pty) Ltd	Danielle Sanderson, Hillary Konigkramer
Traffic	WSP Group Africa (Pty) Ltd	Christo Bredenhann

All specialist studies will include a description of the baseline environment, the identification and assessment of potential impact (including cumulative impacts) and the provision of management and mitigation measures. The terms of reference for each of the above mentioned specialist studies during the EIR phase of the project are detailed below.

SOIL AND LAND CAPABILITY

Only one significant land capability impact was identified during the scoping phase viz. the loss of grazing land available within the study area. However, this is unavoidable given that the purpose of the proposed project which will physically occupy the land previously used for grazing.

The EIA phase will draw upon the relevant specialist reports (Water Availability Assessment, Land Capability and Wetland Assessment, Social-Economic Assessment, Heritage Assessment, Visual Assessment, Avifauna Assessment, and Traffic Assessment). It is anticipated that these reports will provide a thorough understanding of the broader impacts associated with the proposed project.

LAND CAPABILITY

The land capability of the proposed areas, comprises a combination of non-arable, low potential grazing land and wilderness areas; hence, the scope of work will entail a desktop study with subsequent targeted ground-truthing to confirm specific findings.

The desktop study will make use of available Land Type mapping for the area, as well as any existing reports that will be made available to WSP | Parsons Brinckerhoff. A site visit will be undertaken to the study area. Representative soil sampling will be conducted within the study area by a suitably competent soil scientist.

In addition to soil-specific observations and sampling, general observations of the land topography, terrain, along with vegetation type and health will be recorded within the study area. Furthermore, the land-use both within and surrounding the proposed development footprint will be ground-truthed.

Based on the observations, representative soil samples will be retrieved from each of the generalised soil-forms encountered within the defined study area. Based on the physical and chemical data for the soils, and in conjunction with climatic, topographical, vegetation and land-use information, the Chamber of Mines guidelines (2007) will be utilised to define the land capability. Whilst it is recognised that the Chamber of Mines methodology specifically relates to mining impacts, the underlying methodology is considered broadly applicable to the objectives of this assessment. On this basis the assessment will class the study area as wetland, arable land, grazing land, or wilderness. This information will feed into the wetland delineation assessment.

WETLAND ASSESSMENT

Wetlands will initially be delineated within the study area on a desktop basis using available mapping resources. This will include a 500m buffer around the proposed boundaries of the development areas. Thereafter, a site visit will be undertaken to delineate wetlands identified within the development footprint. Given the arid nature of the development area near Aggeney's, with no watercourses currently identified within a 500m buffer, it is expected that site works will be largely non-onerous and will solely consist of a ground-truthing exercise to ensure that no unanticipated wetlands are present.

Wetland areas will be delineated with reference to the Department of Water Affairs publication 'A Practical Field Procedure for Identification and Delineation of Wetland and Riparian Areas'. Soil wetness indicators in the upper 0.5m will be used as the primary wetland indicators, with vegetation types serving as supporting evidence. The boundary of each wetland will be marked at appropriate intervals using a hand-held Global Positioning System (GPS). All delineation information will be assimilated to produce delineation maps in Geographic Information System (GIS) formats. All delineated wetlands will be buffered as per the relevant Department of Water and Sanitation and Department of Environmental Affairs guidelines.

The goods and services supplied by any wetlands identified will be quantified through a functional assessment using the WET-EcoServices Tool. The tool provides guidelines for scoring the importance of a wetland in delivering regulatory and supporting benefits (e.g. toxicant removal, sediment trapping, erosion control and flood attenuation) and cultural and provisioning benefits (e.g. tourism and recreation, provision of water and natural resources). The outcomes of the functional assessment will be used to rationalise wetland buffer zones.

Based on the wetland assessments, in conjunction with the proposed development plan, an impact assessment will be conducted for the study area. This will be undertaken using a recognised impact matrix system (DEAT, 1998) to ensure all procedures for the investigation, assessment and communication of the potential consequences or impacts of activities on the environment as set out in the National Environmental Management Act (107 of 1998) 24(4b) are met. This will include an assessment of the cumulative impacts (i.e. the combined, incremental impacts of other past, present or reasonably foreseeable activities) that pose an environmental risk. WSP | Parsons Brinckerhoff will outline likely suitable mitigation measures to limit the impacts of the proposed project on the delineated wetlands.

REPORTING

A draft Land Capability and Wetland Assessment report will be compiled during the EIA phase, defining in more detail the land capability and wetland assessment within the proposed development area. Furthermore, the associated potential impacts and mitigation measures will be described in in-depth. Following comments from the relevant stakeholders, the final report will be updated and submitted with the final EIA report.

BIODIVERSITY

The current study is based on a site visit, a desktop assessment of the study area as well as prior knowledge of the wider area resulting from previous work in the area. Additional work that will be conducted for the EIA phase of the development includes the following:

- Identification and quantification of the abundance and distribution of species of conservation concern within the site and especially within the development footprint.
- Evaluate the possible impact of the development on landscape connectivity in the field based on the likely use of the area as a corridor for movement by fauna as well as any local impacts on faunal communities. This should include the identification of any corridors that should be kept clear of development at the site and any buffers required around such features.
- Identify sensitive faunal habitats that should be avoided and measures that should be implemented to reduce impacts on fauna in general.
- Consider the potential impact of the development on CBAs and broad-scale ecological processes at the site. This should consider the habitats affected by the current development, including a detailed characterization of the small CBA patches, as well as the overall impact of renewable energy development in the area at a broader scale.
- Assess the contribution of the current development to cumulative habitat loss within the NPAES Focus Area and the potential impact of this on future conservation options in the area.
- Evaluate, based on the site attributes, what the most applicable mitigation measures to reduce the impact of the development on the site would be and if there are any areas where specific precautions or mitigation measures should be implemented.
- Assess the impacts identified above in light of the site-specific findings and the final layout to be provided by the developer.

AVIFAUNA

The Birds and Renewable Energy Specialist Group (BARESG), convened by BirdLife South Africa and the Wildlife and Energy Programme of the Endangered Wildlife Trust, proposes the following guidelines and monitoring protocols for evaluating utility-scale solar energy development proposals. The Guidelines are aimed at environmental assessment practitioners, avifaunal specialists, developers and regulators and propose a tiered assessment process, including:

- Initial screening or scoping – an initial assessment of the likely avifauna and possible impacts, preferably informed by a brief site visit and by desk-top collation of available data; also including the design of a site-specific survey and monitoring project should this be deemed necessary. This has been completed.
- Data collection – further accumulation and consolidation of the relevant avian data, possibly including the execution of baseline data collection work as specified by the scoping study, intended to inform the avian impact study. This is currently happening through an onsite monitoring programme which is aimed at providing a baseline picture of the avifauna over a period of a year.

- Impact assessment - a full assessment of the likely impacts and available mitigation options, based on the results of systematic and quantified monitoring which is currently taking place. This will include the systematic assessment of all the identified impacts.

HERITAGE

The EIA phase study needs to fulfil the requirements of heritage impact assessment as defined in section 38 of the NHRA. This means that the assessment has to cover the full range of potential heritage resources as defined in the National Heritage Resources Act 25 of 1999.

The aim of the EIA would be to identify and assess the significance of all heritage resources on the property, to assess the preferred and alternative options and to rate them in terms of significance, to determine the potential impacts on the heritage resources, and where appropriate to recommend “no-go” areas and to propose mitigation if avoidance is not possible.

- SAHRA needs to be informed of the proposed development and they will indicate the range and type of specialist heritage studies they require;
- The proposed study area, including proposed routes of linear infrastructure (water pipe lines, power lines and access roads) must be subjected to a field survey by the heritage practitioner/archaeologist. They must walk those sections of the study area (including powerline and water pipeline options) which have been identified in this report as of heritage sensitivity;
- The significance of each find will need to be assessed along with the impacts of the proposed activity;
- In the case of impacts to significance heritage resources, the proposed mitigation measures may include the “No-Go” alternative, avoidance, archaeological excavations or monitoring during earthworks;
- The heritage specialist should consider the cumulative impact of a number of solar facilities in the Aggeneys area on the heritage of the study area and make recommendations for mitigation.

VISUAL

The goal of visual impact assessment is not to predict whether specific individuals will find solar energy projects attractive or not. Instead, the goal is to identify important visual characteristics of the surrounding landscape, especially the features and characteristics that contribute to scenic quality, as the basis for determining how and to what degree a particular project will affect those scenic values (Vissering, 2011).

Thus the primary aim of the visual impact assessment phase will be to ensure that visual impacts are adequately assessed and considered so that the relevant authorities can decide if the proposed project has unreasonable or undue visual impacts.

The secondary aim is to identify effective and practical mitigation measures. The study will use the above analysis of the visual characteristics, value and sense of place of the receiving environment as a baseline. Emphasis will be placed on sensitive visual resources and community concerns.

Qualitative as well as quantitative techniques and criteria will be used in the evaluation and clearly documented to ensure the reliability and credibility of conclusions and recommendations. The VIA will comply with the Department of Environmental Affairs and Development Planning’s Guideline For Involving Visual and Aesthetic Specialists in EIA Processes (2005).

The study will include the following:

- Refining of the baseline study, description of the visual character of the sites and zone of visual influence, if required.

- Refining the list of identified visual impacts resulting from the proposed installations (with consideration of any public and/or relevant authorities' concerns).
- Assessment of visual impacts based on standard VIA rating criteria, namely:
 - Quality of landscape – the aesthetic excellence and significance of the visual resources and scenery;
 - Visual absorption capacity – the potential of the landscape to conceal the proposed development;
 - Viewshed analysis (visibility) – the geographic area from which the project may be visible (view catchment);
 - Visual intrusion (or integrity) – the level of congruence or integration with existing landscape; and
 - Viewer numbers and sensitivity – the level of acceptable visual impact is influenced by the type of visual receptors.
- Assessment of the significance of the visual impacts, rated according to the Hacking methodology (provided by Environmental Consultants), which includes:
 - Severity, extent, duration and probability to determine consequence; and
 - Consequence considered with status (positive or negative impact) and confidence to determine significance.
- Impacts will be rated before mitigation and after (assuming) mitigation if applicable.
- Development of mitigation measures to reduce visual impacts and enhance any positive visual benefits.

SOCIAL

There were no significant socio-economic impacts identified during the socio-economic screening study, and there is sufficient information available for the proposed project site and study area. It is therefore proposed that a desktop SIA is undertaken during the EIA phase for the proposed project.

The desktop assessment will include a review of the information contained within other specialist studies, as well as insights from the scoping phase stakeholder engagement process. This process will allow for the assessment of key socio-economic issues relating to the proposed project. An outline of the proposed approach is provided below.

DESKTOP REVIEW

- Specialist Reports - The relevant specialist reports, and related data, will be reviewed including the Visual, Hydrological, Heritage, Land Capability, Traffic, and Fauna and Flora assessment. It is anticipated that these reports will provide a thorough understanding of the broader impacts associated with the project that may have a bearing on the social landscape. The biophysical impacts will provide confirmation of the anticipated socio-economic impacts beyond the site boundary.
- Stakeholder ENGAGEMENT Review - There will be no direct stakeholder engagement undertaken during the SIA. A review of the scoping phase stakeholder engagement and comments and response report will, however, be undertaken to obtain insight into the local social and socio-economic issues and inform the assessment of the potential socio-economic impacts

IMPACT ASSESSMENT AND RECOMMENDATIONS

Potential socio-economic impacts associated with the proposed project will be evaluated using a recognised risk assessment methodology in line with the National Environmental Management Act

(107 of 1998). In addition the Western Cape Guideline for Involving Social Assessment Specialists in EIA Processes (Barbour, 2007), will be used to inform the socio-economic assessment. Recommendations resulting from the impact assessment will be developed, in line with international best practice, to contribute towards socio-economic sustainability during all phases of the proposed project.

REPORTING

The Draft SIA Report will be compiled, including the socio-economic context, potential impacts, assessment, and mitigation recommendations. Following stakeholder comment on the report, the final report will be updated and submitted with the final EIA Report.

TRAFFIC

The Scope of each TIA (per facility) will be determined as per the requirements of the relevant National Standards, i.e. South African Committee of Transport Officials (COTO), TMH 16, Volume 1 & 2, South African Traffic Impact and Site Traffic Assessment Manual, Version 1.0, August 2012. Furthermore the COTO TMH17 South African Trip Data Manual, Version 1.01, dated September 2013 will be utilised as basis to determine the construction and operational vehicle trip generation of the facility.

Due to the expected low trip generation (construction phase only & operational phase negligible), only a Traffic Impact Statement (TIS) will be required, as per COTO standards. Each TIS will cover, *inter alia*:

- Previous traffic related studies, submissions and approvals (if relevant).
- Description of the extent of the development, including location and land-use/s
- Description of the phased development of the facility (if applicable)
- Record of liaison with authorities
- Record of site visits
- Description of the local and potentially affected road network, including planning and comment on the road condition, where information is available
- Description of latent development in the vicinity of the facility that may also have an impact on the local road network
- Assessment of the required site access, parking and internal circulation
- Assessment of expected trip generation (construction & operational phases)
- Capacity analysis (construction & operational phases), including an assessment of the expected total E80's (heavy axle loading) for the life cycle of the facility.
- Assessment of public transport and Non-motorised transport (if applicable)
- Recommendations and conclusions with regards to the required traffic and transport related road upgrades.

9.6 IMPACT ASSESSMENT METHODOLOGY

The EIA uses a methodological framework developed by WSP | Parsons Brinckerhoff to meet the combined requirements of international best practice and NEMA, Environmental Impact Assessment Regulations, 2014 (GN No. 982) (the "EIA Regulations").

As required by the EIA Regulations (2014), the determination and assessment of impacts will be based on the following criteria:

- Nature of the Impact
- Significance of the Impact
- Consequence of the Impact
- Extent of the impact
- Duration of the Impact
- Probability if the impact
- Degree to which the impact:
 - can be reversed;
 - may cause irreplaceable loss of resources; and
 - can be avoided, managed or mitigated.

Following international best practice, additional criteria have been included to determine the significant effects. These include the consideration of the following:

- Magnitude: to what extent environmental resources are going to be affected;
- Sensitivity of the resource or receptor (rated as high, medium and low) by considering the importance of the receiving environment (international, national, regional, district and local), rarity of the receiving environment, benefits or services provided by the environmental resources and perception of the resource or receptor); and
- Severity of the impact, measured by the importance of the consequences of change (high, medium, low, negligible) by considering inter alia magnitude, duration, intensity, likelihood, frequency and reversibility of the change.

It should be noted that the definitions given are for guidance only, and not all the definitions will apply to all of the environmental receptors and resources being assessed. Impact significance was assessed with and without mitigation measures in place.

METHODOLOGY

Impacts are assessed in terms of the following criteria:

- a) The **nature**, a description of what causes the effect, what will be affected and how it will be affected

NATURE OR TYPE OF IMPACT	DEFINITION
Beneficial / Positive	An impact that is considered to represent an improvement on the baseline or introduces a positive change.
Adverse / Negative	An impact that is considered to represent an adverse change from the baseline, or introduces a new undesirable factor.
Direct	Impacts that arise directly from activities that form an integral part of the Project (e.g. new infrastructure).
Indirect	Impacts that arise indirectly from activities not explicitly forming part of the Project (e.g. noise changes due to changes in road or rail traffic resulting from the operation of Project).
Secondary	Secondary or induced impacts caused by a change in the Project environment (e.g. employment opportunities created by the supply chain requirements).
Cumulative	Impacts are those impacts arising from the combination of multiple impacts from existing projects, the Project and/or future projects.

b) The physical extent:

SCORE	DESCRIPTION
1	the impact will be limited to the site;
2	the impact will be limited to the local area;
3	the impact will be limited to the region;
4	the impact will be national; or
5	the impact will be international;

c) The duration, wherein it is indicated whether the lifetime of the impact will be:

SCORE	DESCRIPTION
1	of a very short duration (0 to 1 years)
2	of a short duration (2 to 5 years)
3	medium term (5–15 years)
4	long term (> 15 years)
5	permanent

d) The magnitude of impact on ecological processes, quantified on a scale from 0-10, where a score is assigned:

SCORE	DESCRIPTION
0	small and will have no effect on the environment.
2	minor and will not result in an impact on processes.
4	low and will cause a slight impact on processes.
6	moderate and will result in processes continuing but in a modified way.
8	high (processes are altered to the extent that they temporarily cease).
10	very high and results in complete destruction of patterns and permanent cessation of processes.

e) The probability of occurrence, which describes the likelihood of the impact actually occurring. Probability is estimated on a scale where:

SCORE	DESCRIPTION
1	very improbable (probably will not happen).
2	improbable (some possibility, but low likelihood).
3	probable (distinct possibility).
4	highly probable (most likely).
5	definite (impact will occur regardless of any prevention measures).

f) The significance, which is determined through a synthesis of the characteristics described above (refer formula below) and can be assessed as low, medium or high;

g) The status, which is described as either positive, negative or neutral;

h) The degree to which the impact can be reversed;

i) The degree to which the impact may cause irreplaceable loss of resources; and

j) The degree to which the impact can be mitigated.

The significance is determined by combining the criteria in the following formula: $S = (E+D+M)*P$, where:

S = Significance weighting

E = Extent

D = Duration

M = Magnitude

P = Probability

The significance weightings for each potential impact are as follows:

OVERALL SCORE	SIGNIFICANCE RATING	DESCRIPTION
< 30 points	Low	where this impact would not have a direct influence on the decision to develop in the area
31-60 points	Medium	where the impact could influence the decision to develop in the area unless it is effectively mitigated
> 60 points	High	where the impact must have an influence on the decision process to develop in the area

The impact significance without mitigation measures will be assessed with the design controls in place. Impacts without mitigation measures in place are not representative of the Project's actual extent of impact, and are included to facilitate understanding of how and why mitigation measures were identified. The residual impact is what remains following the application of mitigation and management measures, and is thus the final level of impact associated with the development of the Project. Residual impacts also serve as the focus of management and monitoring activities during Project implementation to verify that actual impacts are the same as those predicted in this EIA Report.

9.7 ENVIRONMENTAL IMPACT REPORT

Once the FSR has been submitted to and accepted by the DEA, the proposed project will proceed into the detailed EIR phase, which involves the detailed specialist investigations. WSP | Parsons Brinckerhoff will produce a Draft EIR after the completion of the required specialist studies. The Draft EIR will provide an assessment of all the identified key issues and associated impacts from the Scoping phase. All requirements as contemplated in the GNR 982 EIA Regulations will be included in the Draft EIR. The Draft EIR will contain, inter alia, the following:

- Details of the EAP who prepared the report and the expertise of the EAP to carry out the S&EIR process, including a curriculum vitae;
- The location of the activity, including the 21 digit Surveyor General code of each cadastral land parcel, where available, the physical address and farm name; and the coordinates of the boundary of the property or properties;
- A plan which locates the proposed activity or activities applied for as well as the associated structures and infrastructure at an appropriate scale;
- A description of the scope of the proposed activity, including all listed and specified activities triggered and being applied for; and a description of the associated structures and infrastructure related to the proposed project;

- A description of the policy and legislative context within which the development is located and an explanation of how the proposed development complies with and responds to the legislation and policy context;
- A motivation for the need and desirability for the proposed development, including the need and desirability of the activity in the context of the preferred location;
- A motivation for the preferred development footprint within the approved site;
- A full description of the process followed to reach the proposed development footprint within the approved site;
- Details of the public participation process undertaken;
- A summary of the issues raised by interested and affected parties, and an indication of the manner in which the issues were incorporated, or the reasons for not including them;
- The environmental attributes associated with the development footprint alternatives focusing on the geographical, physical, biological, social, economic, heritage and cultural aspects;
- The impacts and risks identified including the nature, significance, consequence, extent, duration and probability of the impacts;
- The methodology used in determining and ranking of potential environmental impacts and risks;
- Positive and negative impacts;
- An assessment of each identified potentially significant impact and risk;
- The possible mitigation measures that could be applied;
- An environmental impact statement;
- A description of any assumptions, uncertainties and gaps in knowledge;
- A reasoned opinion as to whether the proposed activity should or should not be authorised;
- An undertaking under oath or affirmation by the EAP; and
- An EMPr.

9.8 STAKEHOLDER AND AUTHORITY ENGAGEMENT

PUBLIC PARTICIPATION PROCESS

Public participation during the EIA phase revolves around the review and findings of the environmental impact assessment, which will be presented in the Draft EIR. All stakeholders will be notified of the progress to date and availability of the Draft EIR, via mail, email and/or SMS. A legislated period of 30 consecutive days will be allowed for public comment. Reports will be made available in the following way:

- Distribution for comment at central public places, which were used during the Scoping phase;
- The document will be made available to download from the WSP website; and
- Copies of CDs will be made available on request.

A public meeting is proposed to be held during this phase (venue to be confirmed). The meeting will be facilitated by key members of the project team. The purpose of the public meeting will be to present the findings of the impact assessment and address issues of concern raised during the Scoping phase.

The following information will be provided to I&APs:

- Initial Site Plan;

- Alternatives;
- A description of activities and operations to be undertaken;
- Baseline information;
- Specialist studies;
- Impact assessment;
- Management measures;
- Monitoring and measuring plan; and
- Closure details.

The information outlined above will be presented in one or more of the following:

- Notifications;
- Scoping Report;
- EIR;
- EMPr; and
- Public meetings.

All comments received during the EIR phase will be recorded in the comments and response report, which will be included in the draft and final EIR. The final EIR will incorporate public comment received on the Draft EIR and will be made available for public review with hard copies distributed mainly to the authorities and key stakeholders.

NOTIFICATION OF ENVIRONMENTAL AUTHORISATION

All stakeholders will receive a letter at the end of the process notifying them of the authority's decision, thanking them for their contributions, and explaining the appeals procedure.

CONSULTATION WITH AUTHORITIES

It is envisaged that consultation with the DEA and NCDENC will coincide with the compilation of the following key documents:

- PoS for EIR;
- Draft EIR/EMPr; and
- Final EIR/EMPR.

Consultation outside of the above deliverables will be undertaken as necessary in order to ensure that the NCDENC and DWS are aware of the status of the project.

9.9 PROGRESSION OF AUTHORISATIONS, PERMITS AND OTHER DEVELOPMENT APPROVALS

A number of authorisations, permits and other development approvals are required to be obtained by the Proponent. **Table 9-5** provides a summary of the development approvals required and the current status of the applications for these approvals.

Table 9-5: Other Development approvals, Authorisations and Permits required for the Proposed Project

APPROVAL REQUIRED	DOCUMENT	DEPARTMENT RESPONSIBLE FOR ISSUING APPROVAL	STATUS OF APPLICATION
A Water Use License in terms of the National Water Act (No. 36 of 1998)		Department of Water and Sanitation	The need for a WUL application process will be identified as part of the S&EIR process. Applications will only be submitted in the event that the project is identified as a preferred bidder.
A Heritage Permit issued by SAHRA in terms of the National Heritage Resource Act (No. 25 of 1999)		South African Heritage Resources Agency	The need for a Heritage Permit application will be identified as part of the S&EIR process. Applications will only be submitted in the event that the project is identified as a preferred bidder.
Forestry License in terms of the National Forest Act (No. 84 of 1998)		Northern Cape Department of Agriculture, Forestry and Fisheries	The need for a Forestry License process will be identified as part of the S&EIR process. Applications will only be submitted in the event that the project is identified as a preferred bidder.
Flora and Fauna Permit in terms of the Northern Cape Nature Conservation Act 9 of 2009		Northern Cape Department of Nature and Conservation	The need for Flora and Fauna Permit processes will be identified as part of the S&EIR process. Applications will only be submitted in the event that the project is identified as a preferred bidder.
Rezoning of Land Permit in terms of Spatial Planning and Land Use Management Act no. 16 of 2013		Khâi-Ma Municipality	The Rezoning of Land Permits will only be submitted in the event that the project is identified as a preferred bidder
Road Traffic Act (No. 29 of 1989)		Department of Transport	Permits will be required for the transportation of abnormal loads on public roads.
South African National Roads Agency Limited and National Roads Act No 7 of 1998		South African National Roads Agency Limited	In the event that a new access road is to be built connecting directly to the N14 an access application will be required.

10 WAY FORWARD

This DSR contains:

- A description of the existing and proposed activities;
- A description of the alternatives considered to date;
- An outline of the proposed process to be followed;
- Information on the proponent, EAP and stakeholders who have chosen to participate in the project;
- An outline of the environment in which the projects fall;
- Information on the potential environmental impacts to be studied in more detail during the EIR phase of the project; and
- Information on the proposed specialist studies to be undertaken.

Based on the desktop studies undertaken to date no environmental fatal flaws have been identified that would prohibit the proposed project from continuing at this stage of the process. However, a number of environmental impacts have been identified as requiring some more in-depth investigation and the identification of detailed mitigation measures. Therefore, a detailed EIA is required to be undertaken in order to provide an assessment of these potential impacts and recommend appropriate mitigation measures.

The recommendation of this report is that detailed specialist studies are undertaken on the proposed site. The scope of work required in the EIR phase of the project is included in the Plan of Study for EIA (Chapter 9).

The DSR is available for public review from the **15 September 2016** to **15 October 2016**. All issues and comments submitted to WSP | Parsons Brinckerhoff will be incorporated in the Comment and Responses Report and will be included in the FSR.

The DSR has been submitted to the delegated competent authorities responsible for authorising this project.

If you have any further enquiries, please feel free to contact:

WSP Environmental (Pty) Ltd

Attention: Ashlea Strong

PO Box 98867, Sloane Park, 2152

Tel: 011 361 1392

Fax: 011 361 1381

E-mail: Ashlea.Strong@wspgroup.co.za

11 REFERENCES

GENERAL

MIKE RYCROFT (EDITOR). EE Publishers. Energize RE: Renewable Energy Supplement. June 2015. Pages 15-17.

RENEWABLES 2015: Global Status Report (REN21- Renewable Energy Policy Network for the 21st Century).

DoE: solar-power: http://www.energy.gov.za/files/esources/renewables/r_solar.html

IPPPP Provincial Report: REIPPPP Focus on the Northern Cape. Volume 1. March 2016

DEPARTMENT OF ENVIRONMENTAL AFFAIRS (2015). EIA Guideline for Renewable Energy Projects. Department of Environmental Affairs, Pretoria, South Africa

SOILS AND LAND CAPABILITY

AGIS. (2007). AGIS Agricultural Geo-Referenced Information System. Retrieved March 10, 2016, from AGIS Agricultural Geo-Referenced Information System Web site: <http://www.agis.agric.za/agisweb/agis.html>

BAILIE, R., ARMSTRONG, R., & REID, D. (2007). The Bushmanland Group supracrustal succession, Aggeneys, Bushmanland, South Africa: Provenance, age of deposition and metamorphism. SOUTH AFRICAN JOURNAL OF GEOLOGY Volume 110, 59 -86.

CHAMBER OF MINES OF SOUTH AFRICA/COALTECH. (2007, November). Guidelines for the Rehabilitation of Mined Land. Guidelines for the Rehabilitation of Mined Land. Johannesburg, Gauteng, South Africa: Chamber of Mines of South Africa/Coaltech.

DEPARTMENT OF AGRICULTURE, FORESTRY AND FISHERIES - DAFF. (2007). Agricultural Geo-Referenced Information System- AGIS. Retrieved March 14, 2016, from AGIS Web site: http://www.agis.agric.za/agisweb/?MIval=agish_content.html

DWS, *Black Mountain Mine / Aggeneys*, Website https://www.dwa.gov.za/orange/Low_Orange/blackmtn.aspx, accessed 2016.

FUJIHARA INDUSTRY CO. (2001). Revised standard soil color charts. Fujihara Industry Company, Tokyo, Japan.

KLINGEBEIL, A. A., & MONTGOMERY, P. H. (1961). Land capability classification. Agriculture handbook no 210. Soil conservation service. Washington DC: US Department of Agriculture.

MINING TECHNOLOGY, *Gamsberg-Skorpion Integrated Project*, <http://www.mining-technology.com/projects/gamsbergskorpion-integrated-project/>, accessed 2016.

MACVICAR, C. N. (1991). Soil Classification: A Taxonomic System for South Africa. Pretoria: Department of Agricultural Development.

MUCINA, L., & RUTHERFORD, M. C. (2006). The vegetation of South Africa, Lesotho, and Swaziland. Strelitzia 19. Pretoria: South African National Biodiversity Institute.

RE, S. (2007). South African Atlas of Climatology and Agrohydrology. In WRC Report 1489/1/06. Pretoria: Water Research Commission.

SCHIFANO, G., EEDEN VAN, O. R., & COERTZE, F. J. (1970). The Soil Maps of Africa: European digital archive of soil maps - EuDASM. Retrieved March 7, 2016, from The Soil Maps of Africa: European digital archive of soil maps - EuDASM Web site: http://eusoiils.jrc.ec.europa.eu/esdb_archive/EuDASM/Africa/maps/afr_za2003_4toge.htm

SOIL WORKING GROUP. (1991). Soil Classification: A taxonomic system for South Africa. Pretoria: Department of Agricultural Development.

USGS U.S Geological Survey. (2009). USGS. Retrieved March 10, 2016, from USGS Website: <http://www.usgs.gov/>

VAN DER MOLEN, W. H., BELTRAN, J. M., & OCHS, W. J. (2007). Annex 1: Estimating soil hydrological characteristics from soil texture and structure. In W. H. van der Molen, J. M. Beltran, & W. J. Ochs, Guidelines and computer programs for the planning and design of land drainage systems (pp. 115 - 116). Rome: Food and Agriculture Organisation of the United Nations.

WISCHMEIER, W H; JOHNSON, C H AND CROSS, V A. (September-October 1971). A soil erodibility nomograph for farmland and construction sites. Journal of Soil and Water Conservation, Vol. 26, No 5, pp 189-193, September-October 1971

WRC - Water Research Commission. 2008. Wetland Management Series: Wet-EcoServices, A technique for rapidly assessing ecosystem services supplied by wetlands. Report No. TT339/08. Water Research Commission, Pretoria, South Africa.

WRC/DWA, *Water Resources 2012 Project (WR2012)*, Water Research Commission and Department of Water Affairs, 2012.

BIODIVERSITY

ALEXANDER, G. & MARAIS, J. 2007. A Guide to the Reptiles of Southern Africa. Struik Nature, Cape Town.

BATES, M.F., BRANCH, W.R., BAUER, A.M., BURGER, M., MARAIS, J., ALEXANDER, G.J. & DE VILLIERS, M. (eds.). 2014. Atlas and Red List of the Reptiles of South Africa, Lesotho and Swaziland. South African National Biodiversity Institute, Pretoria.

BRANCH W.R. 1998. Field guide to snakes and other reptiles of southern Africa. Struik, Cape Town.

BROWNLIE, S. 2005. Guideline for Involving Biodiversity Specialists in EIA Processes: Edition 1. CSIR Report No ENV-S-C 2005 053 C. Provincial Government of the Western Cape, Department of Environmental Affairs & Development Planning, Cape Town. 63 pp.

CLARK, V.R., BARKER, N.P., & MUCINA, L. 2011. The Roggeveldberge – notes on a botanically hot area on a cold corner of the southern Great Escarpment, South Africa. South African Journal of Botany 77: 112-126.

DESMET, P AND MARSH A. 2008. Namakwa District Biodiversity Sector Plan. Available from BGIS at <http://bgis.sanbi.org/namakwa/project.asp>.

DE VILLIERS CC, DRIVER A, CLARK B, EUSTON-BROWN DIW, DAY EG, JOB N, HELME NA, HOLMES PM, BROWNLIE S AND REBELO AB (2005) Fynbos Forum Ecosystem Guidelines for

Environmental Assessment in the Western Cape. Fynbos Forum and Botanical Society of South Africa, Kirstenbosch.

DU PREEZ, L. & CARRUTHERS, V. 2009. A Complete Guide to the Frogs of Southern Africa. Struik Nature., Cape Town.

MINTER LR, BURGER M, HARRISON JA, BRAACK HH, BISHOP PJ & KLOEPFER D (EDS). 2004. Atlas and Red Data book of the frogs of South Africa, Lesotho and Swaziland. SI/MAB Series no. 9. Smithsonian Institution, Washington, D.C

MUCINA L. & RUTHERFORD M.C. (eds) 2006. The Vegetation of South Africa, Lesotho and Swaziland. Strelitzia 19. South African National Biodiversity Institute, Pretoria.

PASSMORE, N.I. & CARRUTHERS, V.C. 1995. South African Frogs: A complete guide. Witwatersrand University Press, Johannesburg. 322 pp.

SKINNER, J.D. & CHIMIMBA, C.T. 2005. The mammals of the Southern African Subregion. Cambridge University Press, Cambridge.

SKOWNO, A.L. HOLNESS S.D AND P. DESMET. 2009. Biodiversity Assessment of the Central Karoo District Municipality. DEAP Report EADP05/2008, 52 pages.

AVIFAUNA

ALLAN, D.G. 1994. The abundance and movements of Ludwig's Bustard *Neotis ludwigii*. Ostrich 65: 95-105

ANIMAL DEMOGRAPHY UNIT. The southern African Bird Atlas Project 2. University of Cape Town. <http://sabap2.adu.org.za>. Accessed 15/04/2016.

ATIENZA, J.C., FIERRO, I.M., INFANTE, O., VALLS, J., DOMINGUEZ, J., 2012. Directrices para la evaluación del impacto de los parques eólicos en aves y murciélagos (versión 3.0). SEO/BirdLife, Madrid.

AVIAN POWER LINE INTERACTION COMMITTEE (APLIC). 2012. Mitigating Bird Collisions with Power Lines: The State of the Art in 2012. Edison Electric Institute. Washington D.C.

BAND, W., MADDERS, M., WHITFIELD, D.P., 2007. Developing field and analytical methods to assess avian collision risk at wind farms. In: Lucas, M., Janss, G.F.E., Ferrer, M. (Eds.), Birds and Wind Farms: Risk Assessment and Mitigation. Quercus, Madrid, pp. 259–275.

BARCLAY R.M.R, BAERWALD E.F AND GRUVER J.C. 2007. Variation in bat and bird fatalities at wind energy facilities: assessing the effects of rotor size and tower height. Canadian Journal of Zoology. 85: 381 – 387.

BARNES, K.N. (ed.) 1998. The Important Bird Areas of southern Africa. BirdLife South Africa: Johannesburg.

BIO THERM. 2016. Unpublished data from wind masts at the Maralla and Esizayo sites.

BARRIENTOS R, PONCE C, PALACIN C, MARTÍN CA, MARTÍN B, ET AL. 2012. Wire marking results in a small but significant reduction in avian mortality at power lines: A BACI Designed Study. PLoS ONE 7(3): e32569. doi:10.1371/journal.pone.0032569.

- BARRIENTOS, R., ALONSO, J.C., PONCE, C., PALACÍN, C. 2011. Meta-Analysis of the effectiveness of marked wire in reducing avian collisions with power lines. *Conservation Biology* 25: 893-903.
- BARRIOS, L., RODRÍGUEZ, A., 2004. Behavioural and environmental correlates of soaring-bird mortality at on-shore wind turbines. *J. Appl. Ecol.* 41, 72–81.
- BEAULAURIER, D.L. 1981. Mitigation of bird collisions with transmission lines. Bonneville Power Administration. U.S. Dept. of Energy.
- BERNARDINO, J., BISPO, R., COSTA, H., MASCARENHAS, M., 2013. Estimating bird and bat fatality at wind farms: a practical overview of estimators, their assumptions and limitations. *New Zeal. J. Zool.* 40, 63–74.
- BEVANGER, K., 1994. Bird interactions with utility structures: collision and electrocution, causes and mitigating measures. *Ibis* 136, 412–425.
- BRIGHT, J.A., LANGSTON, R.H.W., BULLMAN, R., EVANS, R.J., GARDNER, S., PEARCE-HIGGINS, J., WILSON, E., 2006. Bird Sensitivity Map to provide Locational Guidance for Onshore Wind Farms in Scotland. RSPB Research Report No. 20.
- CALVERT, A.M., BISHOP, C.A., ELLIOT, R.D., KREBS, E.A., KYDD, T.M., MACHTANS, C.S., ROBERTSON, G.J., 2013. A synthesis of human-related avian mortality in Canada. *Avian Conserv. Ecol.* 8 (2), 11.
- CAMIÑA A. 2013. Pre-Construction Monitoring of Bird Populations in Maanhaarberg WEF De Aar, Northern Cape. Report to Longyuan Mulilo De Aar Wind Power Pty (Ltd).
- CAMIÑA, A. 2012a. Email communication on 12 April 2012 to the author by Alvaro Camiña, Spanish ornithologist with 8 years' experience in avifaunal monitoring at wind farms in Spain.
- CAMIÑA, A. 2012b. Email communication on 17 November 2012 to the author by Alvaro Camiña, Spanish ornithologist with 8 years' experience in avifaunal monitoring at wind farms in Spain.
- CAMIÑA, A. 2014. Pre-Construction Monitoring of bird populations in Maanhaarberg WEF De Aar, Northern Cape. Unpublished report to Longyuan Mulilo De Aar Wind Power Pty (Ltd).
- CÁRCAMO, B., KRET, E., ZOGRAFOU, C., VASILAKIS, D., 2011. Assessing the Impact of Nine Established Wind Farms on Birds of Prey in Thrace, Greece. Technical Report. WWF Greece, Athens.
- CARRETE, M., SÁNCHEZ-ZAPATA, J.A., BENÍTEZ, J.R., LOBÓN, M., DONÁZAR, J.A., 2009. Large scale risk-assessment of wind-farms on population viability of a globally endangered long-lived raptor. *Biol. Conserv.* 142, 2954–2961.
- CEC, 2007. California Guidelines for Reducing Impacts to Birds and Bats from Wind Energy Development. Commission Final Report. California Energy Commission, Renewables Committee, and Energy Facilities Siting Division, and California Department of Fish and Game, Resources Management and Policy Division.
- DAHL, E.L., MAY, R., HOEL, P.L., BEVANGER, K., PEDERSEN, H.C., RØSKAFT, E., STOKKE, B.G., 2013. White-tailed eagles (*Haliaeetus albicilla*) at the Smøla wind-power plant, Central Norway, lack behavioral flight responses to wind turbines. *Wildl. Soc. Bull.* 37, 66–74.

- DE LUCAS, M., FERRER, M., BECHARD, M.J., MUÑOZ, A.R., 2012a. Griffon vulture mortality at wind farms in southern Spain: distribution of fatalities and active mitigation measures. *Biol. Conserv.* 147, 184–189.
- DE LUCAS, M., JANSS, G.F.E., WHITFIELD, D.P., FERRER, M., 2008. Collision fatality of raptors in wind farms does not depend on raptor abundance. *J. Appl. Ecol.* 45, 1695–1703.
- DE LUCAS, M.; JANSS, G.; FERRER, M. 2004. The Effects of a Wind Farm on Birds in a Migration Point: The Strait of Gibraltar. *Biodiversity & Conservation*, 13(2), 395-407.
- DESHOLM, M., FOX, A.D., BEASLEY, P.D.L., KAHLERT, J., 2006. Remote techniques for counting and estimating the number of bird-wind turbine collisions at sea: a review. *Ibis* 148, 76–89.
- DOOLING, R., 2002. Avian Hearing and the Avoidance of Wind Turbines. National Renewable Energy Laboratory, Colorado.
- DREWITT, A.L., LANGSTON, R.H.W., 2006. Assessing the impacts of wind farms on birds. *Ibis*, 29–42.
- DREWITT, A.L., LANGSTON, R.H.W., 2008. Collision effects of wind-power generators and other obstacles on birds. *Ann. N. Y. Acad. Sci.* 1134, 233–266.
- DUERR, A.E., MILLER, T.A., LANZONE, M., BRANDES, D., COOPER, J., O'MALLEY, K., MAISONNEUVE, C., TREMBLAY, J., KATZNER, T., 2012. Testing an emerging paradigm in migration ecology shows surprising differences in efficiency between flight modes. *PLoS ONE* 7 (4), e35548.
- ERICKSON, W.P., JOHNSON, G.D., STRICKLAND, M.D., YOUNG, D.P., SERNKA, K.J., GOOD, R.E., 2001. Avian Collisions with Wind Turbines: A Summary of Existing Studies and Comparisons to Other Sources of Avian Collision Mortality in the United States. RESOLVE, Inc., (US).
- ERICKSON, W.P., JOHNSON, G.D., YOUNG JR., D.P.Y., 2005. A Summary and Comparison of Bird Mortality from Anthropogenic Causes with an Emphasis on Collisions. General Technical Reports. USDA Forest Service General Technical Report PSWGTR-191.
- EVERAERT, J., 2014. Collision risk and micro-avoidance rates of birds with wind turbines in Flanders. *Bird Study* 61, 220–230.
- EVERAERT, J., STIENEN, E.M., 2008. Impact of wind turbines on birds in Zeebrugge (Belgium). In: Hawksworth, D., Bull, A. (Eds.), *Biodiversity and Conservation in Europe*. Springer, Netherlands, pp. 103–117.
- EVERAERT, J., STIENEN, E.W.M., 2007. Impact of wind turbines on birds in Zeebrugge (Belgium). *Biodivers. Conserv.* 16, 3345–3359.
- FARFAN M.A., VARGAS J.M., DUARTE J. AND REAL R. (2009). What is the impact of wind farms on birds? A case study in southern Spain. *Biodiversity Conservation*. 18:3743-3758).
- FERRER, M., DE LUCAS, M., JANSS, G.F.E., CASADO, E., MUNOZ, A.R., BECHARD, M.J., CALABUIG, C.P. 2012. Weak relationship between risk assessment studies and recorded mortality on wind farms. *Journal of Applied Ecology*. 49. p38-46.
- FURNESS, R.W., WADE, H.M., MASDEN, E.A., 2013. Assessing vulnerability of marine bird populations to offshore wind farms. *J. Environ. Manage.* 119, 56–66.

- GARTHE, S., HÜPPOP, O., 2004. Scaling possible adverse effects of marine wind farms on seabirds: developing and applying a vulnerability index. *J. Appl. Ecol.* 41, 724–734.
- GOVE, B., LANGSTON, RHW., MCCLUSKIE, A., PULLAN, JD. & SCRASE, I. 2013. Wind Farms and Birds: An Updated Analysis Of The Effects Of Wind Farms On Birds, And Best Practice Guidance On Integrated Planning And Impact Assessment. T-PVS/Inf (2013) 15. Report prepared by BirdLife International on behalf of the Bern Convention.
- HALE, A.M, HATCHETT, S.E, MEYER, J.A, & BENNETT. V.J.2014. No evidence of displacement due to wind turbines in breeding grassland songbirds. Volume 116, 2014, pp. 472–482 DOI: 10.1650/CONDOR-14-41.1.
- HARRISON, J.A., ALLAN, D.G., UNDERHILL, L.G., HERREMANS, M., TREE, A.J., PARKER, V & BROWN, C.J. (eds). 1997. The atlas of southern African birds. Vol 1 & 2. BirdLife South Africa, Johannesburg.
- HERRERA-ALSINA, L., VILLEGAS-PATRACA, R., EGUIARTE, L.E., ARITA, H.T., 2013. Bird communities and wind farms: a phylogenetic and morphological approach. *Biodivers. Conserv.* 22, 2821–2836.
- HOBBS, J.C.A. & LEDGER J.A. 1986a. The Environmental Impact of Linear Developments; Power lines and Avifauna. Proceedings of the Third International Conference on Environmental Quality and Ecosystem Stability. Israel, June 1986.
- HOBBS, J.C.A. & LEDGER J.A. 1986b. Power lines, Birdlife and the Golden Mean. *Fauna and Flora*, 44:23-27.
- HOCKEY P.A.R., DEAN W.R.J., AND RYAN P.G. 2005. Robert's Birds of Southern Africa, seventh edition. Trustees of the John Voelcker Bird Book Fund, Cape Town.
- HODOS, W., 2003. Minimization of Motion Smear: Reducing Avian Collisions with Wind Turbines. Report NREL/SR-500-33249. Washington, DC.
- HOOVER, S.L., MORRISON, M.L., 2005. Behavior of red-tailed hawks in a wind turbine development. *J. Wildl. Manage.* 69, 150–159.
- HOOVER, S.L., MORRISON, M.L., 2005. Behavior of red-tailed hawks in a wind turbine development. *J. Wildl. Manage.* 69, 150–159.
- HÖTKER, H., THOMSEN, K.M., KÖSTER, H., 2006. Impacts on biodiversity of exploitation of renewable energy sources: the example of birds and bats. Facts, Gaps in Knowledge, Demands for Further Research, and Ornithological Guidelines for the Development of Renewable Energy Exploitation. Michael-Otto-Institut im NABU, Bergenhusen.
- HOWELL, J.A. 1997. Avian Mortality at rotor swept area equivalents Altamont Pass and Montezuma Hills, California. Report for Kenetech Wind Power
- HULL, C.L., STARK, E.M., PERUZZO, S., SIMS, C.C., 2013. Avian collisions at two wind farms in Tasmania, Australia: taxonomic and ecological characteristics of colliders versus non-colliders. *New Zeal. J. Zool.* 40, 47–62.
- HÜPPOP, O., DIERSCHKE, J., EXO, K.-M., FREDRICH, E., HILL, R., 2006. Bird migration studies and potential collision risk with offshore wind turbines. *Ibis* 148, 90–109.
- HUSO, M.M.P., DALTHORP, D., 2014. Accounting for unsearched areas in estimating wind turbine-caused fatality. *J. Wildl. Manage.* 78, 347–358.

IUCN 2015.4 IUCN Red List of Threatened Species (<http://www.iucnredlist.org/>).

JANSS, G.F.E., 2000. Avian mortality from power lines: a morphologic approach of a species-specific mortality. *Biol. Conserv.* 95, 353–359.

JENKINS, A. & SMALLIE, J. 2009. Terminal velocity: the end of the line for Ludwig's Bustard? *Africa Birds and Birding*. Vol 14, No 2.

JENKINS, A., DE GOEDE, J.H. & VAN ROOYEN, C.S. 2006. Improving the products of the Eskom Electric Eagle Project. Unpublished report to Eskom. Endangered Wildlife Trust.

JENKINS, A.R., DE GOEDE, J.H., SEBELE, L. & DIAMOND, M. 2013. Brokering a settlement between eagles and industry: sustainable management of large raptors nesting on power infrastructure. *Bird Conservation International* 23: 232-246.

JENKINS, A.R., SMALLIE, J.J. & DIAMOND, M. 2010. Avian collisions with power lines: a global review of causes and mitigation with a South African perspective. *Bird Conservation International* 20: 263-278.

JOHNSON, G.D., ERICKSON, W.P., STRICKLAND, M.D., SHEPHERD, M.F., SHEPHERD, D.A., 2002. Collision mortality of local and migrant birds at a large-scale wind-power development on Buffalo Ridge, Minnesota. *Wildl. Soc. Bull.* 30, 879–887.

JOHNSTON, N.N., BRADLEY, J.E., OTTER, K.A., 2014. Increased flight altitudes among migrating golden eagles suggest turbine avoidance at a Rocky Mountain wind installation. *PLoS ONE* 9, e93030.

KATZNER, T.E., BRANDES, D., MILLER, T., LANZONE, M., MAISONNEUVE, C., TREMBLAY, J.A., MULVIHILL, R., MEROVICH, G.T., 2012. Topography drives migratory flight altitude of golden eagles: implications for on-shore wind energy development. *J. Appl. Ecol.* 49, 1178–1186.

KERLINGER, P., GEHRING, J.L., ERICKSON, W.P., CURRY, R., JAIN, A., GUARNACCIA, J., 2010. Night migrant fatalities and obstruction lighting at wind turbines in North America. *Wilson J. Ornithol.* 122, 744–754.

KITANO, M., SHIRAKI, S., 2013. Estimation of bird fatalities at wind farms with complex topography and vegetation in Hokkaido, Japan. *Wildl. Soc. Bull.* 37, 41–48.

KOOPS, F.B.J. & DE JONG, J. 1982. Vermindering van draadslachtoffers door markering van hoogspanningsleidingen in de omgeving van Heerenveen. *Electrotechniek* 60 (12): 641 – 646.

KRIJGSVELD, K.L., AKERSHOEK, K., SCHENK, F., DIJK, F., DIRKSEN, S., 2009. Collision risk of birds with modern large wind turbines. *Ardea* 97, 357–366.

KRUGER, R. & VAN ROOYEN, C.S. 1998. Evaluating the risk that existing power lines pose to large raptors by using risk assessment methodology: The Molopo Case Study. *Proceedings of the 5th World Conference on Birds of Prey and Owls*. August 4-8, 1998. Midrand, South Africa.

KRUGER, R. 1999. Towards solving raptor electrocutions on Eskom Distribution Structures in South Africa. Bloemfontein (South Africa): University of the Orange Free State. (M. Phil. Mini-thesis)

LANGGEMACH, T. 2008. Memorandum of Understanding for the Middle-European population of the Great Bustard, German National Report 2008. Landesumweltamt Brandenburg (Brandenburg State Office for Environment).

LANGLANDS, M. 2015. Personal communication on 5 April 2016 to the author by a member of the St. Francis Bay Bird Club.

LANGSTON, R.W., PULLAN, J.D., 2003. Windfarms and birds: an analysis of the effects of wind farms on birds, and guidance on environmental criteria and site selection issues. BirdLife International to the Council of Europe, Bern Convention. RSPB/ Birdlife in the UK.

LEDDEY, K.L., HIGGINS, K.F., NAUGLE, D.E., 1999. Effects of wind turbines on upland nesting birds in conservation reserve program grasslands. *Wilson Bulletin* 11, 100–104.

LEDGER, J. 1983. Guidelines for Dealing with Bird Problems of Transmission Lines and Towers. Eskom Test and Research Division. (Technical Note TRR/N83/005).

LEDGER, J.A. & ANNEGARN H.J. 1981. Electrocutation Hazards to the Cape Vulture (*Gyps coprotheres*) in South Africa. *Biological Conservation* 20:15-24.

LEDGER, J.A. 1984. Engineering Solutions to the Problem of Vulture Electrocutations on Electricity Towers. *The Certificated Engineer*, 57:92-95.

LEDGER, J.A., J.C.A. HOBBS & SMITH T.V. 1992. Avian Interactions with Utility Structures: Southern African Experiences. Proceedings of the International Workshop on Avian Interactions with Utility Structures. Miami (Florida), Sept. 13-15, 1992. Electric Power Research Institute.

LEKUONA, J.M., URSUA, C., 2007. Avian mortality in wind plants of Navarra (Northern Spain). In: deLucas, M., Janss, G., Ferrer, M. (Eds.), *Birds and Wind Farms*. Quercus Editions, Madrid, pp. 177–192.

LONGCORE, T., RICH, C., MINEAU, P., MACDONALD, B., BERT, D.G., SULLIVAN, L.M., MUTRIE, E., GAUTHREAU, S.A., AVERY, M.L., CRAWFORD, R.L., MANVILLE, A.M., TRAVIS, E.R., DRAKE, D., 2013. Avian mortality at communication towers in the United States and Canada: which species, how many, and where? *Biol. Conserv.* 158, 410–419.

LOSS S.R., WILL, T., MARRA, P.P. Estimates of bird collision mortality at wind facilities in the contiguous United States. *Biological Conservation* 168 (2013) 201–209.

LOSS, S.R., WILL, T., LOSS, S.S., & MARRA, P.P. 2014. Bird–building collisions in the United States: Estimates of annual mortality and species vulnerability. *The Condor* 116(1):8-23. 2014.

MARNEWICK, M.D., RETIEF E.F., THERON N.T., WRIGHT D.R., ANDERSON T.A. 2015. Important Bird and Biodiversity Areas of South Africa. Johannesburg: Birdlife South Africa.

MARTIN, G., SHAW, J., SMALLIE J. & DIAMOND, M. 2010. Bird's eye view – How birds see is key to avoiding power line collisions. Eskom Research Report. Report Nr: RES/RR/09/31613.

MARTIN, G.R., 2011. Understanding bird collisions with man-made objects: a sensory ecology approach. *Ibis* 153, 239–254.

MARTIN, G.R., 2012. Through birds' eyes: insights into avian sensory ecology. *J. Ornithol.* 153, 23–48.

MARTIN, G.R., KATZIR, G., 1999. Visual fields in short-toed eagles, *Circaetus gallicus* (Accipitridae), and the function of binocularity in birds. *Brain Behav. Evol.* 53, 55–66.

MARTIN, G.R., PORTUGAL, S.J., MURN, C.P., 2012. Visual fields, foraging and collision vulnerability in *Gyps* vultures. *Ibis* 154, 626–631.

- MAY, R., BEVANGER, K., VAN DIJK, J., PETRIN, Z., BRENDE, H., 2012a. Renewable Energy Respecting Nature. A Synthesis of Knowledge on Environmental Impacts of Renewable Energy financed by the Research Council of Norway, NINA Report. Trondheim.
- MAY, R., HAMRE, O., VANG, R., NYGARD, T., 2012b. Evaluation of the DTBird Videosystem at the Smøla Wind-Power Plant. Detection Capabilities for Capturing Near-turbine Avian Behaviour. NINA Report 910. Trondheim.
- MCGRADY, M.J., GRANT, J.R., BAINBRIDGE, I.P., MCLEOD, D.R.A., 2002. A model of golden eagle (*Aquila chrysaetos*) ranging behavior. *J. Raptor Res.* 36, 62–69.
- McISAAC, H.P., 2001. Raptor acuity and wind turbine blade conspicuity. In: National Avian-Wind Power Planning Meeting IV. Resolve Inc., Washington, DC, pp. 59– 87.
- MCLEOD, D.R.A., WHITFIELD, D.P., MCGRADY, M.J., 2002. Improving prediction of golden eagle (*Aquila chrysaetos*) ranging in western Scotland using GIS and terrain modeling. *J. Raptor Res.* 36, 70–77.
- MORINHA, F., TRAVASSOS, P., SEIXAS, F., MARTINS, A., BASTOS, R., CARVALHO, D., MAGALHÃES, P., SANTOS, M., BASTOS, E., CABRAL, J.A., 2014. Differential mortality of birds killed at wind farms in Northern Portugal. *Bird Study* 61, 255–259.
- MUCINA, L. & RUTHERFORD, M.C. (Eds) 2006. The vegetation of South Africa, Lesotho and Swaziland. *Strelitzia* 19. South African National Biodiversity Institute, Pretoria.
- O'ROURKE, C.T., HALL, M.I., PITLIK, T., FERNÁNDEZ-JURICIC, E., 2010. Hawk eyes I: diurnal raptors differ in visual fields and degree of eye movement. *PLoS ONE* 5, e12802.
- OSBORN, R.G., DIETER, C.D., HIGGINS, K.F., USGAARD, R.E., 1998. Bird flight characteristics near wind turbines in Minnesota. *Am. Midl. Nat.* 139, 29–38.
- PEARCE-HIGGINS, J.W., STEPHEN, L., DOUSE, A., & LANGSTON, R.H.W. 2012. Greater impacts on bird populations during construction than subsequent operation: result of multi-site and multi-species analysis. *Journal of Applied Ecology* 2012, 49, 396-394)
- PEARCE-HIGGINS, J.W., STEPHEN, L., LANGSTON, R.H.W., BAINBRIDGE, I.P., BULLMAN, R., 2009. The distribution of breeding birds around upland wind farms. *J. Appl. Ecol.* 46, 1323–1331.
- PLONCZKIER, P., SIMMS, I.C., 2012. Radar monitoring of migrating pink-footed geese: behavioural responses to offshore wind farm development. *J. Appl. Ecol.* 49, 1187–1194.
- RAAB, R., JULIUS, E., SPAKOVSKY, P. & NAGY, S. 2009. Guidelines for best practice on mitigating impacts of infrastructure development and afforestation on the Great Bustard. Prepared for the Memorandum of Understanding on the conservation and management of the Middle-European population of the Great Bustard under the Convention on Migratory species (CMS). Birdlife International. European Division.
- RAAB, R., SPAKOVSKY, P., JULIUS, E., SCHÜTZ, C. & SCHULZE, C. 2010. Effects of powerlines on flight behaviour of the West-Pannonian Great Bustard *Otis tarda* population. Bird Conservation International. Birdlife International.
- RALSTON, S. 2016. Avifaunal mortality at operational wind farms in South Africa. Birdlife South Africa, in litt. March 2016.

- RETIEF E.F., DIAMOND M, ANDERSON M.D., SMIT, H.A., JENKINS, A & M. BROOKS. 2012. Avian Wind Farm Sensitivity Map. Birdlife South Africa <http://www.birdlife.org.za/conservation/birds-and-wind-energy/windmap>.
- ROSSOUW, W. 2016. Personal communication by experienced bird monitor and member of the St. Francis Bird Club to the author via text message on 20 March 2016.
- SAIDUR, R., RAHIM, N.A., ISLAM, M.R., SOLANGI, K.H., 2011. Environmental impact of wind energy. *Renew. Sust. Energ. Rev.* 15 (5), 2423–2430.
- SCOTTISH NATURAL HERITAGE. 2010. Use of Avoidance Rates in the SNH Wind Farm Collision Risk Model. SNH Avoidance Rate Information & Guidance Note.
- SHAMOUN-BARANES, J., LESHEM, Y., YOM-TOV, Y., LIECHTI, O., 2003. Differential use of thermal convection by soaring birds over central Israel. *Condor* 105 (2), 208– 218.
- SHAW, J.M. 2013. Power line collisions in the Karoo: Conserving Ludwig's Bustard. Unpublished PhD thesis. Percy FitzPatrick Institute of African Ornithology, Department of Biological Sciences, Faculty of Science University of Cape Town May 2013.
- SMALLIE, J. 2015. In litt. Verreaux's Eagle *Aquila verreauxii* wind turbine collision fatalities. Short note. Wild Skies Ecological Services.
- SMALLWOOD, K. S. 2007. Estimating wind turbine-caused bird mortality. *Journal of Wildlife Management* 71:2781-2791.
- SMALLWOOD, K.S. 2013. Comparing bird and bat fatality-rate estimates among North American wind-energy projects. *Wildlife Society Bulletin* 37: 19-33.
- SMALLWOOD, K.S., KARAS, B., 2009. Avian and bat fatality rates at old-generation and repowered wind turbines in California. *J. Wildl. Manage.* 73, 1062–1071.
- SMALLWOOD, K.S., RUGGE, L., HOOVER, S., THELANDER, M.L., CARL, M., 2001. Intra- and Inter-turbine string comparison of fatalities to animal burrow densities at Altamont Pass. In: *Proceedings of the National Avian-Wind Power Planning Meeting IV*. RESOLVE Inc., Washington, DC, Carmel, California, p. 183.
- SMALLWOOD, K.S., RUGGE, L., MORRISON, M.L., 2009. Influence of behavior on bird mortality in wind energy developments. *J. Wildl. Manage.* 73, 1082–1098
- SMALLWOOD, K.S., THELANDER, C.G., 2004. Developing Methods to reduce Bird Mortality in the Altamont Pass Wind Resource Area. PIER Final Project Report. California Energy Commission.
- SOVACOO, B.K., 2009. Contextualizing avian mortality: a preliminary appraisal of bird and bat fatalities from wind, fossil-fuel, and nuclear electricity. *Energy Policy* 37, 2241–2248.
- T. K. STEVENS, A. M. HALE, K. B. KARSTEN, V. J. BENNETT. An analysis of displacement from wind turbines in a wintering grassland bird community. *Biodivers Conserv* (2013) 22:1755–1767 DOI 10.1007/s10531-013-0510-8.
- TAYLOR, M.R. (ed.) 2015. The Eskom Red Data Book of Birds of South Africa, Lesotho and Swaziland. Birdlife South Africa, Johannesburg.

WATER AVAILABILITY

BRACKEN, N., MACKNICK, J., TOVAR-HASTINGS, A., KOMOR, P., GERRITSEN, M., MEHTA, S. Concentrating Solar Power and Water Issues in the U.S. Technical Report NREL/TP-6A50-61376, March, 2015.

DWAF, Department of Water Affairs and Forestry, Internal Question Paper No. 10 (Question No. 484), 2007

DWAF, WARMS Database, accessed 2016.

DWS, Development of Reconciliation Strategies for Lark Bulk Water Supply Systems: Orange River – Reserve Requirement Scenarios and Scheme Yields, Report No. P RSA D000/00/18312/13, 2015.

DWS1, Introduction to the Orange River Basin, Website <https://www.dwa.gov.za/orange/intro.aspx>, accessed 2016.

DWS2, Black Mountain Mine / Aggeneys, Website https://www.dwa.gov.za/orange/Low_Orange/blackmtn.aspx, accessed 2016.

KHAI-MA LOCAL MUNICIPALITY, Integrated Development Plan for 2012-2017, 2011

KHAI-MA LOCAL MUNICIPALITY, The Local Government Handbook, Khâi-Ma Local Municipality (NC067), Website: <http://www.localgovernment.co.za/locals/view/170/Khâi-Ma-Local-Municipality>, accessed 2016.

MINING TECHNOLOGY, Gamsberg-Skorpion Integrated Project, <http://www.mining-technology.com/projects/gamsbergskorpion-integrated-project/>, accessed 2016.

ORASECOM, Environmental Flow Requirements Volume 1 (Main Report), Support to Phase 2 of the ORASECOM Basin-Wise Integrated Water Resources Management Plan Work Package 5: Assessment of Environmental Flow Requirements, 2010

ORASECOM, The Orange Sequ River Basin Infrastructure Catalogue, Orange Senqu River Commission, Report 001/2012, 2012.

PELLADRIFT WATER BOARD, Pelladrift Water Board 2011/12 Report to Portfolio Committee (Parliament), April 2013.

SANS, South African National Standard for Drinking Water (SANS 241), 2011.

SEDIBENG WATER, Namakwa Water Pipeline Scheme Feasibility Study: Regional Bulk Infrastructure Grant: Appendix G (2011).

SEDIBENG WATER, Sedibeng Water Annual Report 2014-2015, 2015.

SEDIBENG WATER, Sedibeng Water Annual Report 2013-2014, 2014.

SESA STERLITE (a Vandeta Company), Vandeta Zinc International Gamsberg-Skorpion Integrated Zinc Project South Africa and Namibia Presentation, 2014.

VAN TONDER, G. BARDENHAGEN, I., RIEMANN, K. VAN BOSCH, J., DZANGA, P AND XU, Y. Manual on Pumping Test Analysis in Fractured Rock Aquifers. Water Research Commission. Report No. 1116/1/02, 2002.

HERITAGE

BEAMONT, P., SMITH, A.B. & VOGEL, J. 1995. Before the Einiqua” the archaeology of the frontier zone. In A.B. Smith (ed). Eniqualand: studies of the Orange River frontier. Cape Town: UCT Press.

BURKE, P. 1995. The siege of O’Okiep: Guerrilla campaign in the Anglo-Boer War. War Museum of the Boer Republics: Bloemfontein.

DE KOCK, S. 2012. Integrated Heritage Impact Assessment: Proposed Boesmanland Solar Farm (75MW): Portion (300HA) of the Farm Zuurwater 62/6, Namaqualand District, Northern Cape Province.

DUNN, E.J. 1931. The Bushmen. London: Charles Griffin & Co.

EKSTEEN, B. 2012. Boere en Basters van die Boesmanland: ‘n geskiedkundige relaas. Bloemfontein: Bytes Document Solutions.

HALKETT, D. 2010. An assessment of impact on archaeological heritage resulting from replacement of a section of the existing bulkwater supply pipeline from Pella to Pofadder, Northern Cape. Unpublished report for Van Zyl Environmental.

HART, T., HALKETT, D & KENDRICK, N. 2014. Heritage Impact Assessment for the Korana Solar Energy Facility on farm Namies South 212/Portion 2; Khâi-Ma Municipality, Northern Cape. Unpublished report for Savannah Environmental (Pty) Ltd.

MORRIS, A. 1992. Skeletons of Contact: a study of protohistoric burials from the lower Orange River Valley, South Africa. Witwatersrand University Press.

MORRIS, D. 1996. Archaeological impact assessment, “Southern Option” powerline ‘Schuitdrif’ to ‘Paulputs’, Pofadder District, Northern Cape. Unpublished report to Eskom.

MORRIS, D. 2011a. A Phase 1 Heritage Impact Assessment for the proposed Aggeneis – Paulputs 220kV transmission line. Unpublished report for SSI Engineers and Environmental Consultants.

MORRIS, D. 2011b. Heritage Impact Assessment: Sato Energy Holdings Zuurwater Photovoltaic energy generation facility development near Aggeneys, Northern Cape Province.

MORRIS, D. 2011c. Black Mountain Concentrated Solar Power Facility development at Aggeneys, Northern Cape Province. Unpublished report for Aurora Power Solutions (Pty) Ltd.

MORRIS, D. 2013. Heritage Impact Assessment: proposed Aggeneys Photovoltaic Energy facility at Bloemhoek near Aggeneys, Northern Cape Province. Unpublished report for Solar Capital.

NIENABER, G.S. & RAPER, P.E. 1977. Toponymica Hottentotica. Raad vir Geesteswetenskaplike Navorsing: Pretoria.

ORTON, J. & WEBLEY, L. 2012a. Heritage Impact Assessment for the proposed Kangnas Wind and Solar Energy facilities, Namakwa Magisterial District, Northern Cape. Unpublished report for Aurecon South Africa (Pty) Ltd.

ORTON, J. & WEBLEY, L. 2012b. Scoping heritage impact assessment for the Pofadder Wind and Solar Energy facility, Kenhardt magisterial District, Northern Cape. Unpublished report prepared for Savannah Environmental (Pty) Ltd.

ORTON, J. & WEBLEY, L. 2013. Heritage Impact Assessment for the Proposed Namies Wind Energy facility near Aggeneys, Northern Cape. Unpublished report for Aurecon South Africa (Pty) Ltd.

ORTON, J. 2013b. Preliminary archaeological mitigation report for the Gamsberg Zince Mine, Aggeneys, Northern Cape. Unpublished report for Black Mountain Mining (Pty) Ltd.

ORTON, J. 2014. Final archaeological mitigation report for the Gamsberg Zince Mine, Aggeneys, Northern Cape. Unpublished report prepared for ERM Southern Africa (Pty) Ltd.

ORTON, J. 2015a. Final archaeological survey for the proposed Konkoonsies II Solar Energy facility, Kenhardt Magisterial District, Northern Cape. Unpublished report prepared for Savannah Environmental (Pty) Ltd.

ORTON, J. 2015b. Heritage Scoping study for Sol Invictus Solar PV development on Ou Taaibosmond 66/5, Namakwaland Magisterial District, Northern Cape. Unpublished report for Savannah Environmental (Pty) Ltd.

PELSER, A. 2011. A report on an archaeological impact assessment (AIA) for the proposed solar energy facility on Konkoonsies 91, Pofadder District, Northern Cape. Unpublished report for Robert de Jong & Associates.

PENN, N. 1995. The Orange River Frontier Zone, C.1700-1805. In (ed) Smith, A.B. Einiqualand: studies of the Orange River Frontier. UCT Press: Rondebosch. pp21-109.

ROBINSON, A.M.L. (ed). 1978. Selected articles from the Cape Monthly Magazine NS, 1870-1876. Cape Town: Van Riebeeck Series. Second Series No 9.

SMITH, AB. 2012. Archaeological report: Proposed 75MW solar facility on Farm 62 Zuurwater, Aggeneys, Northern Cape Province. Unpublished report for Cape EAPrac.

THOMPSON, G. 1827. Travels and adventures in Southern Africa. Reprint, Cape Town: Africana Connoisseurs Press, 1962.

VAN DER WALT, J. 2014. Archaeological/Heritage recommendations regarding the proposed power line between Aggeneys Solar 1 and Aggeneys MTS substation. Unpublished report for PV Africa Development (Pty) Ltd by Heritage Contracts and Archaeological Consulting.

WEBLEY, L. 1997. Jakkalsberg A and B: the cultural material from two pastoralist sites in the Richtersveld, Northern Cape. Southern African Field Archaeology Vol 6(1):3-19.

WEBLEY, L. & HALKETT, D. 2011. Heritage Impact Assessment: Proposed Aggeneys – Oranjemond 400kV line and substations upgrade, Northern Cape Province. Unpublished report for Savannah Environmental (Pty) Ltd.

WEBLEY, L. & HALKETT, D. 2012. Heritage Impact Assessment: Proposed Aggeneys Photo-Voltaic Solar Power Plant on Portion 1 of the farm Aroams 57, Northern Cape Province. Unpublished report for Savannah Environmental (Pty) Ltd.

PALAEONTOLOGICAL

AGENBACHT, A.L.D. 2007. The geology of the Pofadder area. Explanation of 1: 250 000 geology sheet 2918. 89 pp. Council for Geoscience, Pretoria.

- ALMOND, J.E. 2009. Contributions to the palaeontology and stratigraphy of the Alexander Bay sheet area (1: 250 000 geological sheet 2816), 117 pp. Unpublished technical report prepared for the Council for Geoscience by Natura Viva cc, Cape Town.
- ALMOND, J.E. 2011. Proposed Sato Energy Holdings (Pty) Ltd photovoltaic project on Portion 3 of Farm Zuurwater 62 near Aggeneys, Northern Cape Province. Recommended exemption from further specialist palaeontological studies or mitigation, 7 pp. Natura Viva cc.
- ALMOND, J.E. 2012. Proposed 75 MW solar facility on Farm Zuurwater 62 (Portions 2 & 3) near Aggeneys, Northern Cape Province. Recommended exemption from further specialist palaeontological studies or mitigation, 6 pp. Natura Viva cc.
- ALMOND, J.E. 2013a. Proposed wind energy facility and associated infrastructure on Namies Wind Farm (Pty) Ltd near Aggeneys, Northern Cape Province. Palaeontological heritage assessment: desktop study, 16 pp. Natura Viva cc.
- ALMOND, J.E. 2013b. Proposed upgrade & repair of water supply infrastructure, Onseepkans, Northern Cape. Recommended exemption from further palaeontological studies, 6pp. Natura Viva cc.
- ALMOND, J.E. 2014. Three proposed Mainstream wind energy facilities and a solar energy facility on Farms 209 and 212 near Pofadder, Northern Cape. Palaeontological heritage basic assessment: desktop study 19 pp. Natura Viva cc, Cape Town.
- ALMOND, J.E. & PETHER, J. 2008. Palaeontological heritage of the Northern Cape. Interim SAHRA technical report, 124 pp. Natura Viva cc., Cape Town.
- CORNELL, D.H. et al. 2006. The Namaqua-Natal Province. In: Johnson, M.R., Anhaeusser, C.R. & Thomas, R.J. (Eds.) The geology of South Africa, pp 325-379. Geological Society of South Africa, Johannesburg & Council for Geoscience, Pretoria.
- DE WIT, M.C.J. 1990. Palaeoenvironmental interpretation of Tertiary sediments at Bosluispan, Namaqualand. *Palaeoecology of Africa and the surrounding islands* 21: 101-118.
- DE WIT, M.C.J. 1993. Cainozoic evolution of drainage systems in the north-western Cape. Unpublished PhD thesis, University of Cape Town, Cape Town, 371 pp.
- DE WIT, M.C.J. 1999. Post-Gondwana drainage and the development of diamond placers in western South Africa. *Economic Geology* 94: 721-740.
- DE WIT, M.C.J. & BAMFORD, M.K. 1993. Fossil wood from the Brandvlei area, Bushmanland as an indication of palaeoenvironmental changes during the Cainozoic. *Palaeontologia africana* 30: 81-89.
- DE WIT, M.C.J., MARSHALL, T.R. & PARTRIDGE, T.C. 2000. Fluvial deposits and drainage evolution. In: Partridge, T.C. & Maud, R.R. (Eds.) *The Cenozoic of southern Africa*, pp.55-72. Oxford University Press, Oxford.
- MACEY, P.H., SIEGFRIED, H.P., MINNAAR, H., ALMOND, J. AND BOTHA, P.M.W. 2011. The geology of the Loeriesfontein Area. Explanation to 1: 250 000 Geology Sheet 3018 Loeriesfontein, 139 pp. Council for Geoscience, Pretoria.
- MACRAE, C. 1999. Life etched in stone. *Fossils of South Africa*, 305 pp. The Geological Society of South Africa, Johannesburg.

MALHERBE, S.J., KEYSER, A.W., BOTHA, B.J.V., CORNELISSEN, A., SLABERT, M.J. & PRINSLOO, M.C. 1986. The Tertiary Koa River and the development of the Orange River drainage. *Annals of the Geological Survey of South Africa* 20, 13-23.

MCCARTHY, T. & RUBIDGE, B. 2005. The story of Earth and life: a southern African perspective on a 4.6-billion-year journey. 334pp. Struik, Cape Town.

MOEN, H.F.G. 2007. The geology of the Upington area. Explanation to 1: 250 000 geology Sheet 2820 Upington, 160 pp. Council for Geoscience, Pretoria.

MOEN, H.F.G. & TOOGOOD, D.J. 2007. The geology of the Onseepkans area. Explanation to 1: 250 000 geology Sheet 2818, 101 pp. Council for Geoscience, Pretoria.

PARTRIDGE, T.C., BOTHA, G.A. & HADDON, I.G. 2006. Cenozoic deposits of the interior. In: Johnson, M.R., Anhaeusser, C.R. & Thomas, R.J. (Eds.) *The geology of South Africa*, pp. 585-604. Geological Society of South Africa, Marshalltown.

SAHRA 2013. Minimum standards: palaeontological component of heritage impact assessment reports, 15 pp. South African Heritage Resources Agency, Cape Town.

SCOTT, L. 2000. Pollen. In: Partridge, T.C. & Maud, R.R. (Eds.) *The Cenozoic of southern Africa*, pp.339-35. Oxford University Press, Oxford.

SENUT, B., PICKFORD, M., WARD, J., DE WIT, M., SPAGGIARI, R. & MORALES, J. 1996. Biochronology of the Cainozoic sediments at Bosluis Pan, Northern Cape Province, South Africa. *South African Journal of Science* 92: 249-251.

VISUAL

ALMOND, J. E. (2011). Paleontological Studies: Proposed Sato Energy Holdings (Pty) Ltd photovoltaic project on Portion 3 of Farm Zuurwater 62 near Aggeneys, Northern Cape Province.

ARRIAZA, M (2004) Assessing Visual Quality in Rural Landscapes. *Landscape and Urban Planning*, Vol. 69, Issue 1 pg 115-125, 15 July 2004.

CORNELL, D.H., THOMAS, R.J., MOEN, H.F.G, REID, D.L., MOORE J.M. AND GIBSON, R.L. (2006). The Namaqua-Natal Province. In: Johnson, M.R., Anhaeusser, C.R. and Thomas, R.J. (Eds.), *The Geology of South Africa*. Geological Society of South Africa, Council for Geoscience, Pretoria, 325-380.

CRAWFORD, D. (1994) Using remotely sensed data in landscape visual quality assessment, *Landscape and Urban Planning*. 30: 17-81

GEOLOGICAL SURVEY, DEPT. MINERAL AND ENERGY AFFAIRS, 1984. Geological Map of South Africa, 1:1 000 000 scale.

HULL, RB AND BISHOP, I.E. (1988) Scenic Impacts of Electricity Transmission Towers: the Influence of Landscape Types and Observer Distance. *Journal of Environmental Management*: 27, 99-108.

JOUBERT P (1986). Namaqualand Metamorphic Complex – A summary. In: Anhaeusser C.R. and Maske S. (Eds.), *Mineral Deposits of Southern Africa Volume II*, Geological Society of South Africa, Johannesburg, 1395-1420.

LANDSCAPE INSTITUTE AND THE INSTITUTE OF ENVIRONMENTAL ASSESSMENT AND MANAGEMENT (2002) Guidelines for Landscape and Visual Impact Assessment, Second Edition, E&FN Spon Press.

LYNCH, K. (1992) Good City Form, The MIT Press, London.

MUCINA L. & RUTHERFORD M.C. (2006). The Vegetation of South Africa, Lesotho and Swaziland. Strelitzia 19. South African National Biodiversity Institute, Pretoria.

OBERHOLZER, B (2005) Guideline for Involving Visual and Aesthetic Specialists in EIA Processes: Edition 1. CSIR Report No.: ENV-S-C 2005 053 F. RSA, Provincial Government of the Western Cape, DEA&DP, Cape Town.

OBERHOLZER, B AND CSIR (2016) Unpublished selected extract from the National Wind and Solar PV Strategic Environmental Assessment.

PROVINCIAL GOVERNMENT OF THE WESTERN CAPE / CNDV AFRICA (2006). Strategic Initiative to Introduce Commercial Land Based Wind Energy Development to the Western Cape.

RAMSAY (1993) in Martin, Y (2012), Visual Impact Assessment for the Proposed Solar Photovoltaic Installation at Grootvlei Power Station, Report 1600/V12 MP.

SCOTTISH GOVERNMENT. 2011. Onshore Wind Turbines. Specific Advice Sheet. <http://www.scotland.gov.uk/Resource/Doc/212607/0120077.pdf>

SOUTH AFRICAN NATIONAL BIODIVERSITY Institute (2012) National Vegetation Map <http://bgisviewer.sanbi.org/BGISLUDS-SL-viewer/Viewer.html?Viewer=National%20vegetation%20map%202009&layerTheme=National%20Vegetation%20Map%202009>

SULLIVAN, R.G. (2012). Visual Impacts of Utility-scale Solar Energy Facilities on Southwestern Desert Landscapes. http://visualimpact.anl.gov/solarvis/docs/Solar_Visual_Impacts.pdf

SULLIVAN, R.G. (2013). Notes from Solar Energy Workshop. <http://www.bia.gov/cs/groups/xieed/documents/document/idc1-021617.pdf>

VISSERING, JEAN. 2011. A Visual Impact Assessment Process for Wind Energy Projects. Clean Energy States Alliance. <http://www.cleanenergystates.org/assets/2011-Files/States-AdvancingWind-2/CESA-Visual-Impacts-Methodology-May2011.pdf>.

WSP | PARSONS BRINCKERHOFF, ENVIRONMENT & ENERGY, AFRICA (2015 update 2016). Technical Information for Specialists Spreadsheet.

YOUNG (2000) First Draft Gamsberg Zinc Project: Specialist Study Report: Visual Environment. Newtown Landscape Architects, 10 March 2000.

SOCIAL

BARBOUR, T. (2007) Guideline for Involving Social Assessment Specialists in EIA Processes, Department of Environmental Affairs and Development Planning, Western Cape Province.

DEPARTMENT OF HEALTH (2012) The 2011 National Antenatal Sentinel HIV & Syphilis Prevalence Survey in South Africa. Department of Health: Directorate – Epidemiology and Surveillance, Cluster: HIMME

KHÂI-MA LOCAL MUNICIPALITY (2011) Integrated Development Plan 2012-2017

NAMAKWA DISTRICT MUNICIPALITY (2012) Draft Revised Integrated Development Plan
Integrated Development Plan 2012-2017

NORTHERN CAPE PROVINCE (2004) Northern Cape Provincial Growth and Development
Strategy (2004 – 2024)

<http://www.localgovernment.co.za/provinces/view/7/northern-cape> [Accessed on March 2016]

STATISTICS SOUTH AFRICA (2012). Census 2011
<http://interactive.statssa.gov.za/superweb/login.do> [Accessed on 28 March 2016]

STATISTICS SOUTH AFRICA (2016) http://www.statssa.gov.za/?page_id=737&id=1 [Accessed
on 5 April 2016]

ERM (Environmental Resource Management (Pty) Ltd) (2013) Environmental and Social Impact
Assessment for Proposed Construction of the Gamsberg Zinc Mine: Draft Report for Black
Mountain Mining (Pty) Ltd, April 2013

Appendix A

CURRICULUM VITAE

Appendix B

EAP DECLARATION OF INTEREST AND UNDERTAKING

Appendix C

SPECIALIST DECLARATIONS

Appendix D

DEA PRE-APPLICATION MEETING MINUTES

Appendix E

STAKEHOLDER DATABASE

Appendix F

ADVERTISEMENT

Appendix G

SOIL, LAND CAPABILITY AND WETLANDS SPECIALIST STUDY

Appendix H

BIODIVERSITY SPECIALIST STUDY

Appendix I

AVIFAUNA SPECIALIST STUDY

Appendix J

HERITAGE SPECIALIST STUDY

Appendix K

PALAEONTOLOGICAL SPECIALIST STUDY

Appendix L

VISUAL SPECIALIST STUDY

Appendix M

SOCIAL SPECIALIST STUDY

Appendix N

A3 MAPS