

EZELSJACHT

Solar Energy Facility

TRAFFIC IMPACT ASSESSMENT



Report prepared for:

SLR Consulting (Pty) Ltd
of
Unit 14, Braehead Office Park
1 Old Main Road,
Kloof Durban
3640

Phone: +27 (0)73 658 7955

Email: scottshaw@slrconsulting.com

Report prepared by:

Athol Schwarz
of
45 Raven St,
West Beach,
Table View
7441

Mobile: +27 (0) 82 777 1961

Email: schwarzathol@gmail.com

CONTENT

<u>Topic</u>	<u>Page</u>
1 EXECUTIVE SUMMARY	1
2 PROJECT SPECIFICATIONS	2
3 ABBREVIATIONS.....	3
4 GLOSSARY	3
5 INTRODUCTION	4
5.1 PROJECT DESCRIPTION.....	4
5.2 TERMS OF REFERENCE	4
5.3 SCOPE AND OBJECTIVES.....	5
5.3.1 Scope.....	5
5.3.2 Objectives	5
5.4 LEGISLATION AND PERMIT REQUIREMENTS	5
5.4.1 Roads.....	5
5.4.2 Vehicle Dimensions	6
5.4.3 Vehicle Loads	6
5.4.4 Abnormal Loads.....	7
5.5 METHODOLOGY.....	7
5.6 ASSUMPTIONS.....	8
5.7 LIMITATIONS.....	9
5.8 SOURCE OF INFORMATION.....	10
6 DESCRIPTION OF THE STUDY AREA	10
6.1 ROAD NETWORK	10
6.1.1 National Road	11
6.1.2 Trunk Roads	12
6.1.3 Main Road.....	13
6.1.4 Minor Roads.....	15
6.2 SITE ACCESS.....	16
6.3 TRANSPORTATION ROUTES.....	17
6.3.1 Commuter Routes.....	17
6.3.2 Freight Routes	18
6.4 RENEWABLE DEVELOPMENTS	20
7 TRAFFIC VOLUMES	21
7.1 STATUS QUO.....	21
7.1.1 Counting Stations.....	21
7.1.2 Baseline Traffic Volumes.....	23
7.2 ROAD NETWORK MODEL.....	24
7.3 CONSTRUCTION PHASE.....	24
7.3.1 Peak Traffic.....	25
7.3.2 Diurnal Traffic.....	26
7.4 OPERATIONAL PHASE	28
7.4.1 Peak Traffic.....	28
7.4.2 Diurnal Traffic.....	29
7.5 DECOMMISSIONING PHASE	29
8 ASSESSMENT OF IMPACTS	30
8.1 CONSTRUCTION PHASE	30
8.2 OPERATIONAL PHASE	32
8.3 DECOMMISSIONING PHASE.....	33
9 ASSESSMENT OF CUMULATIVE IMPACTS.....	33
9.1 CONSTRUCTION PHASE	34
9.2 OPERATIONAL PHASE	35
9.3 DECOMMISSIONING PHASE.....	36
10 RISKS AND IMPACTS	37
10.1 RISKS.....	37
10.1.1 Traffic Volumes	37
10.1.2 Road Condition	37
10.1.3 Reduced Visibility.....	38
10.1.4 Pedestrians and Animals.....	38
10.2 IMPACTS	39
10.2.1 Construction Phase.....	39
10.2.2 Operational Phase	42
10.2.3 Decommissioning Phase	43
10.2.4 No-go Alternative	43

11	TRAFFIC MANAGEMENT PLAN	43
12	CONCLUSION AND RECOMMENDATIONS	45
	12.1 CONCLUSION	45
	12.2 RECOMMENDATIONS.....	47
13	APPENDICES	48
	APPENDIX 1 - DECLARATION	49
	APPENDIX 2 - NEMA REQUIREMENTS FOR SPECIALIST REPORTS	50
	APPENDIX 3 - CURRICULUM VITAE	51

LIST OF TABLES

	<u>Page</u>
Table 1 - Synopsis of Project Specifications	2
Table 2 - List of Abbreviations	3
Table 3 - Definitions.....	3
Table 4 - Distribution of the Workforce	18
Table 5 - Distance - Port Terminals.....	19
Table 6 - Distance - Major Commercial Centres	20
Table 7 - Surrounding Renewable Developments.....	20
Table 8 - Counting Station 4410.....	22
Table 9 - Counting Station 4411.....	23
Table 10 - Counting Station 4412.....	23
Table 11 - Construction Phase - Peak Traffic.....	26
Table 12 - Construction Phase - Diurnal Traffic	28
Table 13 - Operational Phase - Peak Traffic	29
Table 14 - Operational Phase - Diurnal Traffic.....	29
Table 15 - Construction Phase - Traffic Volumes.....	30
Table 16 - Construction Phase - Traffic Assessment	31
Table 17 - Operational Phase - Traffic Volumes	32
Table 18 - Operational Phase - Traffic Assessment.....	33
Table 19 - Cumulative Constructional Phase - Traffic Volume.....	34
Table 20 - Cumulative Constructional Phase - Traffic Assessment	35
Table 21 - Cumulative Operational Phase - Traffic Volumes	35
Table 22 - Cumulative Operational Phase - Traffic Assessment.....	36
Table 23 - Construction Phase - Increased Road Incidents.....	39
Table 24 - Construction Phase - Road Degradation	40
Table 25 - Construction Phase – Dust.....	41
Table 26 - Construction Phase - Intersection Safety.....	41
Table 27 - Operational Phase - Intersection Safety	42

LIST OF FIGURES

	<u>Page</u>
Figure 1 - Ezelsjacht Solar Energy Facility.....	4
Figure 2 - Road Network.....	11
Figure 3 - N1 Road	11
Figure 4 - TR 03102.....	12
Figure 5 - TR 03201.....	13
Figure 6 - MR 00291.....	14
Figure 7 - MR 00295.....	14
Figure 8 - OP 0548	15
Figure 9 - OP05749	16
Figure 10 - Access Point at 18.95 km (Left)	16
Figure 11 - Access Point at 18.95 km (North)	17
Figure 12 - Access Point at 18.95 km (North)	17
Figure 13 - Surrounding Towns.....	18
Figure 14 - Freight Routes - Port Terminals.....	19
Figure 15 - Freight Routes - Commercial Centres	20
Figure 16 - Adjacent Proposed Renewable Energy Project.....	21
Figure 17 - Counting Station.....	22
Figure 18 - Baseline AADT.....	24
Figure 19 - Road Network Model.....	24

Document Control

<i>Revision</i>	<i>Date</i>	<i>Description</i>	<i>Author</i>
<i>Rev 0</i>	<i>10th Oct 2022</i>	<i>Issued to Client for Use</i>	<i>Athol Schwarz</i>

DISCLAIMER

This report has been prepared for the exclusive use and benefit of South Africa Mainstream Renewable Power Developments (Pty) Ltd (the "Client") as part of an Agreement and is subjected to the following disclaimer:

This report (including any enclosures and attachments) may be used by the Client within the framework of the Agreement and shall not be used by any other party nor for any other purpose without the written consent of the Author. The Client indemnifies the Author against any liability, loss, damage, or cost howsoever arising, including by way of a third-party claim, from a breach of this undertaking by the Client. The findings, conclusions and opinions of the Author, therefore, on the scope of the Agreement between the Author and the Client. Portions of the Reports may be of a privileged and confidential nature relating to the Agreement. The Author accepts no responsibility for damages, if any, suffered by any third party as a result of decisions made or actions based on the Reports. While it is believed that the information contained in the Report is reliable under the conditions and subject to the limitations outlined in the Agreements, the Report will be based in part on information not within the control of the Author and the Author, therefore, cannot and does not guarantee its accuracy. Unless otherwise expressly stated, the analyses contained in the Reports will be developed from information provided by the Client. The Author will not audit such information and the Author makes no representations as to the validity or accuracy thereof. The comments in the Reports will reflect the Author's best judgement in light of the information available at the time of preparation. The Author will have conducted an investigation required in terms of the aforementioned scope of the Agreements.

While all professional care has been undertaken in preparation of this Report, the Author accepts no liability for loss or damages incurred as a result of reliance placed upon its content.

1 EXECUTIVE SUMMARY

South Africa Mainstream Renewable Power Developments (Pty) Ltd, hereafter referred to as “Mainstream”, is proposing to develop a 140 megawatts (MW) Wind Energy Facility (WEF), a 110 MW Solar Photovoltaic (PV) Energy Facility (SEF), Battery Energy Storage (BESS), and their supporting grid infrastructure, collectively known as the “Ezelsjacht Renewable Energy Facilities”. The overall objective of the proposed development is to generate electricity employing renewable energy technologies capturing wind and solar energy to feed into the national grid.

The proposed Ezelsjacht SEF is located approximately 13 km southeast of the town De Doorns, within the Cape Winelands District Municipality of the Western Cape Province. The site proposed for the SEF component of the renewable energy facility falls within both the Breede Valley Municipality.

An Environmental Authorisation (EA) from the National Department of Forestry, Fisheries and the Environment (DFFE) is required for the proposed project. However, the provincial authority (i.e. the Western Cape Department of Environmental Affairs and Development Planning - WC DEADP) will also be consulted.

This Traffic Impact Assessment is for the Ezelsjacht SEF, hereafter referred to as the ‘proposed development’. Based on the latest available information, the proposed development will consist of approximately 420 000 solar panels, with a total maximum generating capacity in the order of 110 MW, this will be finalised once the solar panel supplier has been identified.

Mr A. Schwarz compiled this Traffic Impact Assessment, in line with the relevant guidelines that were followed to provide a technical appraisal of the traffic impact of the proposed developments on the existing road network during the construction, operation and decommissioning phases of the projects. A site visit was conducted in September 2022.

There are several other renewable energy projects developed or to be developed within a 30 km radius of the proposed development. However, none of these developments contributes to the traffic volumes of the proposed development.

The road network, used to commute personnel to and from the proposed development, and used to transport equipment and material, including abnormal loads, to the proposed development, are all well-established. The most likely transportation route for equipment and material is anticipated to be via the national road NR 001.

Traffic generation estimates used in this assessment are based on the experience of similar projects. The worst-case scenario for the cumulative impact has been adopted, which assumes the simultaneous construction of the Ezelsjacht WEF, the Ezelsjacht SEF, and all related infrastructure over a period of two years. The most significant increase in traffic will result from the daily commuting of personnel to and from the proposed development. The projected increase in traffic on the public road network does not exceed the 50 vehicles per hour, the threshold stipulated in the South African Traffic Impact and Site Traffic Assessment Manual (2012).

There will be a notable increase in traffic volumes on the road network during the construction phase of the proposed developments and less conspicuous during the operational phase. This report has assessed the cumulative impact of the additional traffic on the surrounding road network and found that the level of service (LOS) on these roads is acceptable. The increase in traffic volumes will lead to more noticeable wear and tear to the surface, especially during the construction phase of the proposed

developments. However, if the roads are regularly maintained this will impact on the structural integrity of the roads within the study area. Due to budgetary constraints within various spheres of government, only minor maintenance is undertaken on the road network. To this end, it is strongly suggested that the developer contributes towards the ongoing maintenance of the road network associated with the various phases of the proposed development.

There are no serious concerns regarding the public road network feeding the proposed development. All-access points to the proposed development shall be designed in accordance with standard geometric requirements.

It should be noted, that it is not possible to determine the expected traffic volumes generated during the decommissioning phase. It can be assumed that these volumes will be lower than during the construction phase as much of the infrastructure (e.g., roads, platforms, etc.) will be retained by the landowners. As part of the decommissioning process, a separate traffic impact assessment should be undertaken since many of the characteristics related to the traffic impact assessment, i.e., access routes, road geometry, traffic volumes, etc., would have changed over the operational life of the development.

A range of management and mitigation strategies are identified for implementation during the construction and operation phases of the development to minimise traffic impacts and reduce community disruption and the risk of traffic incidents.

Thus, from a traffic and transportation perspective, there are no constraints or notable impacts that would jeopardise the implementation of this development.

2 PROJECT SPECIFICATIONS

A synopsis of the project specification for the proposed development is provided in Table 1.

Table 1 - Synopsis of Project Specifications

Project Components Description	Specifications & Footprint areas
Location	The proposed Ezelsjacht SEF is located approximately 13 km south-east of the town De Doorns, the facility falls within both the Breede Valley Local Municipality, of the Western Cape.
Access Roads	Access to the site will be from the MR 00295 (R318). Existing access roads will be utilised as far as possible. The width of the access roads will be up to approximately 7 m wide.
Application site area	±370 hectares
Affected Farm Portions	Portion 6 of the Farm Ratelbosch No.149 (SG Code C08500000000014900006)
Number of solar panels and generation capacity	Up to approximately 420 000 solar panels to be installed on steel structures with a generation capacity of up to 110 MW
Operations and Maintenance Complex	<p>The following infrastructure is to be shared with the associated grid (25 hectares):</p> <ul style="list-style-type: none"> • Operations and Maintenance Building approximately 1 hectares • Temporary laydown or staging area, approximately 3 hectares to be located on the site identified for the substation. It should be noted that no construction camps will be required to house workers overnight as all workers will be accommodated in the surrounding towns. • On-site Grid Connection and Substation: 33kV/132 kV, shared on site/step up substation with IPP portion (33/132kV transformer) and Eskom portion (132kV switching portion). • A Battery Energy Storage System (BESS) of up to 500 MWh will be located next to the IPP portion/yard of the shared onsite 33 kV / 132kV substation and will cover an area of 5 ha. The storage capacity and type of technology would be determined at a later stage during the development phase but will most likely be either solid state or redox flow.
Fencing	Galvanized steel and 1.8 m in height.
Associated Infrastructure	<ul style="list-style-type: none"> • Cabling: Underground 33kV cables, buried along internal access roads where feasible; and outside of the road footprints and where there are topography and environmental concerns. Overhead 33kV power lines will be constructed, using monopole structures where burying is not possible due to technical, geological, environmental or topographical constraints. 33kV overhead power lines supported by 132 kV pylons of approximately 22 m high will be required, as well as tracks for access to the pylons.

Project Components Description	Specifications & Footprint areas
	<ul style="list-style-type: none"> • Electrical transformers adjacent to Panels (typical footprint of up to approximately 2 m x 2 m) to step up the voltage to between 11 kV and 33 kV; • Other Associated infrastructure (to be confirmed)

3 ABBREVIATIONS

The following abbreviations have been used in this document.

Table 2 - List of Abbreviations

Abbreviation	Meaning
AADT	Average Annual Daily Traffic
ADT	Average Daily Traffic
BA	Basic Assessment
BESS	Battery Energy Storage System
COTO	Committee of Transport Officials
DFFA	Department of Forestry, Fishing and the Environment
EIA	Environmental Impact Assessment
EPCM	Engineering, Procurement, Construction and Management
IAP	Interested and Affected Parties
km/h	Kilometre per hour
LOS	Level of Service
MW	Megawatt
NEMA	National Environmental Management Act
O&M	Operation and Maintenance
PDP	Professional Driving Permit
REIPPPP	Renewable Energy Independent Power Producer Procurement Programme
RNIS	Road Network Information System
SANRAL	South African National Roads Agency SOC Ltd
SEF	Solar Energy Facility
TMP	Traffic Management Plan
vpd	Vehicle per day
vph	Vehicle per hour
v/km	Vehicle per kilometre
WEF	Wind Energy Facility
WTG	Wind Turbine Generator

4 GLOSSARY

The following definitions apply to these words, which have been used in this document.

Table 3 - Definitions

Word/Phrase	Definitions
Average Annual Daily Traffic	An Average Annual Daily Traffic is the total traffic volume (in both directions) generated in a year, including school and public holidays and weekends, divided by the number of days in the year.
Average Daily Traffic	An Average Daily Traffic is the total traffic (in both directions) generated in a twenty-four-hour period on a typical working weekday.
Diurnal	Diurnal means happening or active during the daytime.
Follower density	Follower density is defined as the number of vehicles per kilometre per lane
Level of Service	The level of service in this document is based on the follower density and expressed as LOS A to LOS F.
Peak Traffic	Traffic at the time it is most busy.
Traffic Volume	Traffic Volume is the number of vehicles passing a specific point in a given time, expressed in vehicles per hour.

Word/Phrase	Definitions
Trip	A Trip is defined as a single (one-directional) movement of vehicles, with either the destination or the origin at the proposed development.

5 INTRODUCTION

5.1 PROJECT DESCRIPTION

Mainstream is proposing to develop a Ezelsjacht SEF, BESS, and their supporting grid infrastructure. The overall objective of the proposed development is to generate electricity employing renewable energy technologies capturing wind and solar energy to feed into the national grid.

The proposed Ezelsjacht SEF is located approximately 13 km southeast of the town De Doorns, which falls in the Breede Valley Local Municipality, within the Cape Winelands District Municipality of the Western Cape Province.

It is proposed that the Ezelsjacht SEF will consist of approximately 420 000 solar panels. The Ezelsjacht SEF will also include internal and/or access roads (with a width of up to 6 m during construction), a construction laydown area/camp, an Operation and Maintenance Building and an Independent Power Producer (IPP) 33 kV / 132 kV portion of the onsite substation.

The extent of the proposed development is shown in Figure 1, together with Portion 6 of the Farm Ratelbosch No.149, on which the proposed developments is to be constructed.

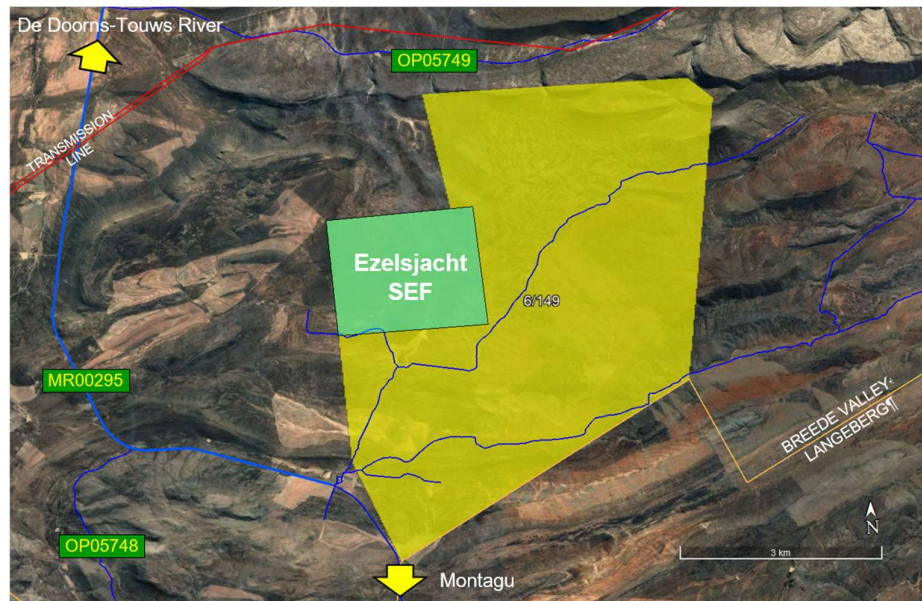

Figure 1 - Ezelsjacht Solar Energy Facility

This Traffic Impact Assessment forms an integral part of the supporting documentation required for the Environmental Authorisation application to the Department of Forestry, Fisheries and the Environment (DFFE).

5.2 TERMS OF REFERENCE

SLR Consulting South Africa (Pty) Ltd appointed Mr A. Schwarz to provide a Traffic Impact Assessment (TIA) for the proposed development.

5.3 SCOPE AND OBJECTIVES

5.3.1 Scope

The proposed developments shall consist of approximately 420 000 solar panels mounted on arrays, the layout of which is still to be finalised.

The scope of this report includes, inter alia:

- Identify the potential road network that could be affected by this development;*
- Determine a traffic baseline against which the potential traffic impacts are to be measured;*
- Identify potential impacts and cumulative impacts that may occur during the construction, operational and decommissioning phases of the development;*
- Determine mitigation and/or management measures which could be implemented to reduce, as far as possible, the effect of negative impacts; and*
- Incorporate and address all issues and concerns raised by Interested and Affected Parties (if and when applicable).*

5.3.2 Objectives

This report aims to determine the potential traffic impact the proposed development will have on the existing road network.

5.4 LEGISLATION AND PERMIT REQUIREMENTS

In terms of the EISA Regulations, 2014, promulgated under the National Environmental Management Act (No 107 of 1998) and published in Government Notice No. R982 (and associated amendments), various aspects of the proposed project may have an impact on the environment and are considered to trigger certain listed activities. These activities are prohibited from being undertaken until an Environmental Authorisation has been obtained from the Competent Authority, namely the national Department of Forestry, Fisheries and the Environment. It should be noted that a full Scoping & EIA processes is required for the Ezelsjacht WEF, while Basic Assessment processes will be undertaken for each of the associated grid infrastructure components (on-site substations & 132kV overhead distribution lines/powerlines).

The DFFE Screening Tool and Report that was generated for the site (as per Regulation 16(1)(v) of the Environmental Impact Assessment Regulations 2014, as amended) concluded that based on the selected classification of activity along with the environmental sensitivities of the proposed development footprint, a traffic impact assessment is identified for inclusion in the assessment report.

No preliminary traffic sensitivities or sensitivity rating was identified or provided based on the DFFE Screening Tool (i.e. a preliminary sensitivity rating was not provided that could then be confirmed or altered based on further assessment). Nevertheless, this Traffic Impact Assessment has been compiled based on desktop research and a site visit in support of the assessment which was undertaken on 24/25 September 2022.

5.4.1 Roads

The relevant legislation associated with the road (infrastructure), transportation and traffic include, inter alia:

- National Water Act (Act 36 of 1998), with regards to all crossings of watercourses;*

- *National Road Traffic Act (Act 93 of 1996);*
- *Advertising on Road and Ribbon Development Act (Act 21 of 1940):*
 - *Regulates the display of advertisements outside some urban regions at places visible from public roads, and the depositing or leaving of disused machinery or refuse and the erection, construction or laying of structures and other things near certain public roads, and the access to certain land from such roads;*
 - *Section 9: Prohibition of the erection of structures near-certain roads;*
 - *Section 9A: Prohibition of the erection of structures or construction of other things near intersections of certain roads;*
 - *Section 10: Restriction of access to land through a fence, etc., along certain roads.*
- *Roads Ordinance Number 19 of 1976:*
 - *Consolidate and amend the law relating to public roads and public paths and to provide for matters incidental thereto;*
 - *Section 13: Erection of gates across public roads and public paths;*
 - *Section 17: Erection of structures on or near public roads;*
 - *Section 18: Access to and exit from certain public roads and public paths.*

5.4.2 Vehicle Dimensions

Regulations 221 to 230 of the National Road Traffic Act relates to vehicle dimensions, the most salient points are summarised below.

Regulation 221: Defines the legislation requirements regarding the overall length of vehicles, and is summarised as follows:

- *a rigid vehicle shall not exceed 12.5 m;*
- *articulated motor vehicle and semi-trailers shall not exceed 18.5 m;*
- *other combinations of motor vehicles (including interlinks, multiple trailers, etc.) shall not exceed 22.0 m;*

Regulation 223: Defines the legislation requirements regarding the overall width of vehicles with a gross mass of 12 000 kilograms or more, shall not exceed 2.6 m.

Regulation 224: Define the legislative requirements regarding the overall height of a vehicle and transported load, which shall not exceed 4.3 m.

Regulation 225: Defines the legislation requirements regarding the maximum turning radius and wheelbase, which shall not exceed 13.1 m or 10.0 m (for a semi-trailer), respectively.

5.4.3 Vehicle Loads

Regulations 231 to 249 of the National Road Traffic Act relates to vehicles loads. The most salient points are summarised below.

Regulation 240: Defines the legislation requirements regarding the mass load carrying capacity on roads. The most relevant points are summarised below:

- *The mass load of a wheel fitted to a steering axle shall not exceed 3 850 kg, and others shall not exceed 4 000 kg;*
- *The mass load of an axle fitted with two wheels, which is the steering axle, shall not exceed 7 700 kg, others shall not exceed 8 000 kg;*
- *The mass load of an axle fitted with four wheels shall not exceed 9 000 kg;*

- *The mass load of an axle unit, which consists of two axles, each of which are fitted with two wheels, acting as a steering axle unit shall not exceed 15 400 kg, and other axle units shall not exceed 16 000 kg;*
- *The mass load of an axle unit, which consists of two axles, each of which are fitted with four wheels, shall not exceed 18 000 kg;*
- *The mass load of an axle unit, which consists of three or more axles, each of which are fitted with two wheels, acting as a steering axle unit shall not exceed 23 100 kg, and other axle units shall not exceed 24 000 kg;*
- *The mass load of an axle unit, which consists of three or more axles, each of which are fitted with four wheels, shall not exceed 24 000 kg;*
- *The axle mass load of an axle unit consists of two axles, one of which is a drive axle with four wheels and the other is an axle with two wheels, the sum of the two axles shall not exceed 18 200 kg.*

Regulation 241: Defines the legislation requirements regarding the mass load-carrying capacity of bridges.

5.4.4 Abnormal Loads

The National Road Traffic Act (Act 93 of 1996) and the National Road Traffic Regulations (2000) prescribe certain limitations on vehicle dimensions and axle and vehicle masses that a vehicle using a public road must comply with. Where the prescribed limits are exceeded, these loads are classified as abnormal loads. Provision for such abnormal vehicles and loads are made in Section 81 of the National Road Traffic, as substituted by Section 23 of the National Road Traffic Amendment Act (Act 64 of 2008).

The requirements and procedures for transporting abnormal loads are contained in the following two documents:

- *“TRH 11 - Dimensional and Mass Limitations and Other Requirements for Abnormal Load Vehicles”; and*
- *“Administrative Guidelines for Granting of Exemption Permits for the Conveyance of Abnormal Loads”.*

5.5 METHODOLOGY

The South African Traffic Impact and Site Traffic Assessment Standards (2014), and the Manual for Traffic Impact Studies (1995), form the basis for this traffic impact assessment.

The methodology adopted in the compilation of this report includes, inter alia:

- *Identify the road network which will be used by vehicles associated with this development and other developments in the area;*
- *Establish the number of vehicle trips generated during the construction, operation and decommissioning of this development;*
- *Determine the mode of transport, vehicle type and size for each trip or category of trip generated during the construction, operational and decommissioning of this development;*
- *Establish peak-hour vehicle trip rate generated during the construction, operation and decommissioning of this development;*

- *Identify and assess the significance and severity of development-related traffic on the existing road network. Where possible comparing the existing traffic volumes on the roads with the traffic generated by this development;*
- *Propose practical measures to mitigate the impacts of development-related traffic on the existing road network.*

5.6 ASSUMPTIONS

The compiling of this report is based on the following assumptions:

GENERAL

- *The Ezelsjacht SEF is envisaged to be constructed over a period of 24 months;*
- *The Ezelsjacht WEF, Ezelsjacht SEF and associated infrastructure, including the individual BESS, Substations, and Grid Connection, are to be constructed simultaneously, which constitutes the worst-case scenario for the TIA;*

SUBSTATION

- *On-site Grid Connection and Substation for the Ezelsjacht WEF and the Ezelsjacht SEF including 33 kV / 132 kV IPP portion of shared on site /step up substation.*

MANPOWER

- *The manpower complement for the proposed Ezelsjacht SEF during the peak construction phase is assumed not to exceed 150 individuals;*
- *The manpower complement for the proposed Ezelsjacht WEF during the peak construction phase is assumed not to exceed 260 individuals;*
- *The expected manpower complement for the construction of the grid connection is expected to be in the order of 60 individuals;*
- *The expected manpower complement for the construction of each substation is expected to be in the order of 40 individuals;*
- *Thus, the combined manpower complement for the construction phase of the Ezelsjacht WEF, Ezelsjacht SEF, BESS and associated infrastructure is assumed to be in the order of 550 individuals;*
- *The manpower complement for the operational phase of the proposed Ezelsjacht SEF is assumed to be in the order of 40 individuals;*
- *The manpower complement for the operational phase of the proposed Ezelsjacht WEF is assumed to be in the order of 40 individuals;*
- *Thus, the combined manpower complement for the operational phase of the Ezelsjacht WEF and Ezelsjacht SEF is assumed to be in the order of 80 individuals;*

WORKFORCE DISTRIBUTION

- *No accommodation is provided on-site.*
- *The workforce for the proposed development is drawn from various towns within 100 km of the proposed development, these towns include Ashton, Bonnievale, De Doorns, Montagu, Robertson, Touws River, and Worcester.*
- *The distribution of the workforce is based on the working-age population in each town modified by the weighting factor relating to the distance the various towns are from the proposed development;*

- *The number of specialists deployed to the area for the proposed development is assumed to be nominal and will not adversely affect the distribution as described above.*

TRAFFIC

- *Delivery routes of equipment and materials to the proposed developments from various commercial centres within South Africa will follow well-established road networks;*
- *The solar panels are to be imported into South Africa via one of the Transnet operated Container Terminals in South Africa;*
- *The final route selection is subject to the limitations specified in the transport permits and the available vehicles to be used by the appointed logistics company;*
- *For analysis purposes the shortest distance of a route to the proposed developments will be adopted;*
- *Construction equipment and materials (other than aggregates) for the proposed development will be transported from the various commercial centres within South Africa;*
- *The supply of raw materials for the manufacture of concrete and road construction, as a worst-case scenario, will be sourced from commercial sources outside the proposed development;*
- *All concrete is envisaged to be mixed at an on-site batching plant, and not transported on the public roads;*
- *The maximum payload of general-purpose vehicles used to transport equipment and material to the site is assumed to be in the order of 20 000 kg;*
- *The transportation of personnel shall be provided by either double cab bakkie (4 Pax), minibuses (16 Pax), or Buses (35, 45 and 55 Pax), all vehicles shall be retained on-site during the day;*

5.7 LIMITATIONS

This report excludes the following:

- *Traffic Management Plan for the development, as this will depend on the construction process adopted by the contractor that is still to be appointed;*
- *Site Development Plan of the infrastructure, including roads, stormwater drainage, amenities, batching plant, etc. within the site boundary that does not affect the public road network;*
- *The geometric details of intersections and entrances onto the site from the public road network, as this will be finalised during the detailed design phase, which will require approval from the relevant roads authorities;*
- *Assessment of risks and impacts associated with loading or off-loading of the vehicles at the site or associated facilities are not addressed since these will be addressed in the Standard Operating Procedures developed by the Engineering, Procurement, Construction and Management (EPCM) contractor for the construction and decommissioning of the development;*
- *The suitability of the minor roads for the delivery and transportation and commuting of personnel will need to be assessed at the time of implementation, as the road conditions could have changed. It must be noted that not all the roads included in this report were evaluated during the site visit; and*

- *The transportation route from the port terminals or commercial centres to the proposed development is the responsibility of the logistics company that will be appointed;*

It should be noted that none of these exclusions is expected to affect the outcome of this assessment.

5.8 SOURCE OF INFORMATION

Information used in compiling this report was drawn from the following sources:

- *Manual for Traffic Impact Studies, Department of Transport, RR 93/635, 1995;*
- *TMH 16, Volume 1 - South African Traffic Impact and Site Traffic Assessment Manual, COTO 2012;*
- *TMH 16, Volume 2 - South African Traffic Impact and Site Traffic Assessment Standards and Requirements Manual, COTO 2014;*
- *TMH 17 - The South African Trip Data Manual, COTO 2012;*
- *TRH 4 - Structural Design of Flexible Pavements for Interurban and Rural Roads, 1996;*
- *TRH 26 - South African Road Classification and Access Management Manual, 2012;*
- *All information relating to the roads within the Western Cape was obtained from the Western Cape Government Road Network Information System (https://rnis.westerncape.gov.za/rnis/rnis_web_reports.main.null);*
- *All data relating to traffic volumes on the roads within the Western Cape were obtained from the Western Cape Government Road Network Information System (https://rnis.westerncape.gov.za/rnis/rnis_web_reports.main.null);*
- *The number of working-age was obtained from the Department of Statistics South Africa (http://www.statssa.gov.za/?page_id=964);*
- *Information regarding mountain passes was obtained from Mountain Passes of South Africa (<https://mountainpassessouthafrica.co.za/>);*
- *Distance and estimated travelling times were obtained using Garmin BaseCamp software (version 4.7.4);*
- *Satellite imagery of the site available on Google Earth was also used for evaluation; and*
- *The photographs used in this report were either taken by the author during the site visit or extracted from Google Earth.*

6 DESCRIPTION OF THE STUDY AREA

6.1 ROAD NETWORK

The existing road network adjacent to the proposed developments is well established, consisting of a combination of national roads, first, second and third-order roads, which provides access to the proposed development from local towns and major commercial centres within South Africa.

The most relevant roads used to access the proposed developments from the surrounding towns (indicated in yellow), are shown in Figure 2, the details of which are delineated below.

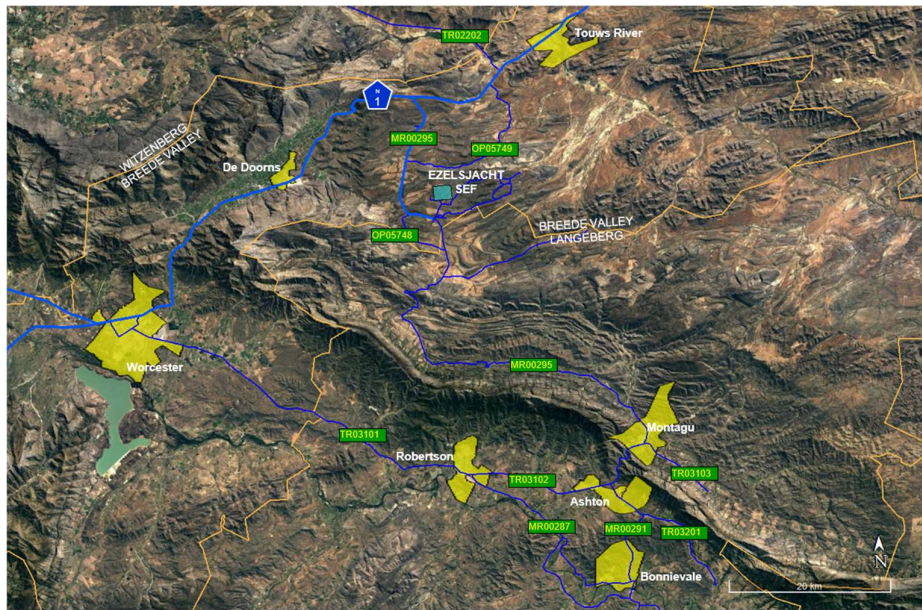

Figure 2 - Road Network

6.1.1 National Road

National Roads are principal arterials providing high mobility between provinces, regions and towns, and are under the jurisdiction of the South African National Road Agency.

NR 001 (N1)

The NR 001 starts at the M6 (western Boulevard) in Cape Town and ends at Beit Bridge Border Post at the Zimbabwe border, passing through or bypassing many towns on route.

The NR 001 is a Class 1 road, generally consisting of a single paved carriageway, with one lane in each direction, with paved shoulders, as shown in Figure 3. Climbing lanes are provided along various sections of the road, and there are turning lanes at major intersections. In many cases, the shoulder is wide enough to allow yellow-line driving. The road is in good condition with a speed limit of 120 km/h.

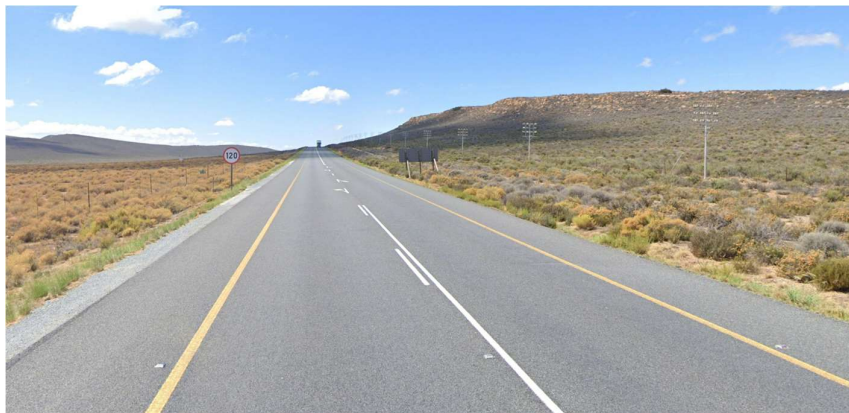

Figure 3 - N1 Road

The section of the N1 most likely to be impacted by the proposed development would be the section between Worcester and Touws River.

The intersection onto MR 00295, will need to be upgraded to accommodate access of abnormal vehicles from the NR 001 onto the MR 00295.

On the N1, between De Doorns and Touws River is the notorious Hex River pass, one of the Western Cape's most dangerous passes for trucking accidents, it is not so much the gradient that is problematic, but the long, straight, momentum-gathering descent which leads suddenly into a dangerously sharp, left-hand bend. Thankfully, a substantial crash barrier prevents out-of-control vehicles from crossing over into the oncoming traffic. A strategically placed arrestor bed halfway down the pass has also helped to reduce the dangers of trucks experiencing brake failure.

6.1.2 Trunk Roads

Trunk roads are minor (secondary) arterial roads, providing mobility between provinces, regions, and towns. The management and maintenance of these roads fall under the jurisdiction of the Provincial Roads Department, in which the roads are located.

Only those truck roads affected by the proposed development are delineated below.

TR 03102

The TR 03102 is 27.3 km long, it starts in Robertson (Reitz Street), passes through Ashton, and ends in Montagu (Church Street).

According to the Western Cape Road Information System, the Functional Class of this road is Class 2. In the rural areas, the road is situated in a 30 m wide servitude consisting of a single paved carriageway, with one lane in each direction, with either gravel shoulders or paved shoulders, a section of the road with paved shoulders is shown in Figure 4. This road is in good condition with a speed limit ranging from 60 km/h in urban areas to 120 km/h in rural areas.



Figure 4 - TR 03102

There are several passes on this section of the road, more details of these passes are provided below.

On the road between Robertson and Ashton, the Malherbeshoogte pass is found, this official pass hardly conforms to the definition of a pass and is hardly noticeable. The 'pass' consists of three gentle bends and climbs just 39 m in altitude over 3 km. It provides access to several points of interest in the Robertson Valley, which include the historic Rietvallei Wine Estate and the well-known Sheilam Cactus Farm.

Cogmans Kloof connects the towns of Ashton and Montagu. The entire 6.5 km road, stretches through a majestic landscape of towering rock formations and a colourful pastoral patchwork. Technically this is much more of a 'poort' than a pass, as the

elevation variances are minor. The road more or less follows the river for the entire length and passes through the mountainside.

TR 03201

The TR 03201 is 45.2 km long, it starts at the TR 03102 (approximately 5 km East of Ashton), and ends at N2 at Swellendam. At chainage 5.7 km there is a junction (to the right) with MR 00291, to Bonnievale.

According to the Western Cape Road Information System, the Functional Class of this road is Class 2. In the rural areas, the road is situated in a 32 m wide servitude consisting of a single paved carriageway, with a width over 11.6 m (including shoulders), with one lane in each direction and paved shoulders, as shown in Figure 5. The road is in good condition with a speed limit of 120 km/h.



Figure 5 - TR 03201

6.1.3 Main Road

Main roads are minor (tertiary) arterial roads, providing mobility between provinces, regions, and towns. The management and maintenance of these roads fall under the jurisdiction of the Provincial Roads Department, in which the roads are located.

Only the main roads affected by the proposed development are delineated below.

MR 00291 (Herry Hill Road)

The MR 00291 is 9.7 km long, it starts at the junction with the TR 03201, and ends at the junction with the MR 00287 in Bonnievale.

According to the Western Cape Road Information System, the Functional Class of this road is Class 3. In the rural areas, the road is situated in a 25 m wide servitude consisting of a single paved carriageway, 6.8 m wide, with one lane in each direction and gravel shoulders, as shown in Figure 6. The road is in fair condition with a speed limit of 100 km/h.



Figure 6 - MR 00291

Skilpadshoogte is a scenic tarred pass that connects the riverside town of Bonnievale with the TR 03201. This is a fairly short pass at 3 km and gains 94 m in altitude, producing an average gradient of 1:32. There are five relatively easy curves and bends along the pass as it meanders up towards the neck and summit called Skilpadshoogte. The steepest section is the final 600 m on the southern side of the summit where the gradient increases to 1:7.

MR 00295 (R318)

The MR 00295 is 78.3 km long, and consists of three sections, the length of these sections is, 20.5 km, 55.0 km and 3.8 km respectively. The MR 00295 starts at the NR 001 (between De Doorns and Touws River) and ends in Montagu (Long Road).

According to the Western Cape Road Information System, the Functional Class of this road is Class 3. In the rural areas, the road is situated in a 25 m wide servitude consisting of a single paved carriageway, 6.8 m wide, with one lane in each direction and paved shoulders, as shown in Figure 7. The road is in fair condition with a speed limit of 100 km/h.



Figure 7 - MR 00295

There are several passes on this section of the road, more details of these passes are provided below

The tarred Rooihoogte Pass drops 370 m in altitude over a distance of 7.6 km, resulting in an average gradient of 1:20. The Rooihoogte Pass was originally known as Thomson's Pass is reputed to be the pass with the highest summit altitude in the Western Cape.

The tarred Burger Pass was originally known as the Koo Pass (serving the fruit-growing region known as the Koo Valley), it was renamed after a local town councillor, Mr. Burger, who expended a lot of energy to influence the authorities to upgrade the

road. Despite the modern engineering, this pass has a combination of dangers - from long momentum gathering straights to very sharp corners.

6.1.4 Minor Roads

Minor roads in the area, have a functional classification of level 5, and are categorised as a Local Access roads, providing direct access to properties. The management and maintenance of this road fall under the jurisdiction of the Provincial Roads Department, in which the roads are located. The minimum required level of service on these roads is a LOS C.

Most of these roads consist of a gravel carriageway, within a 20 m wide servitude. Only the Minor Roads affected by the proposed development are delineated below.

OP 05748

Road OP 05748 is a 7.2 km long gravel road, starting at the MR 00295 (on Zout Riviers Berg), terminating on farm 171 Ezelsjacht and farm 7 De Braak.

The road is narrow and the eastern section of this road is extremely undulating and not conducive to abnormal traffic as shown in Figure 8.



Figure 8 - OP 0548

OP 05749

Road OP 05749 is a 22.7 km long gravel road, starting at the NR 001 (near Grootstraat Farm), and ending at MR 00295 (on farm Helpmekaar). The eastern section of this road will be used to construct the grid connection.

The road is narrow and not well utilised, as shown in Figure 9.



Figure 9 - OP05749

6.2 SITE ACCESS

Access to the proposed development is envisaged to be at chainage 18.95 km, on the MR 00295, as delineated below. However, this could change as the final access to the proposed development will only be finalised during the design phase of the project.

Access Point at 18.95 km

The existing access point, to the left, at chainage 18.95, is access to the guest farm at Zout River, and is shown in Figure 10.



Figure 10 - Access Point at 18.95 km (Left)

The sighting distance to the north from this intersection is shown in Figure 11.



Figure 11 - Access Point at 18.95 km (North)

The sighting distances to the south from this intersection are shown in Figure 12.



Figure 12 - Access Point at 18.95 km (North)

Although sighting distances in both directions appear to be acceptable. The suitability of this access point would have to be comprehensively assessed during the design phase of the project. The safety of landowners and their guests needs to be taken into account at this access point.

6.3 TRANSPORTATION ROUTES

6.3.1 Commuter Routes

In light of the current economic situation in the country and REIPPPP requirements, it is assumed that the workforce will be drawn from surrounding communities. There are several towns within a 100 km radius of the proposed development, from which the proposed workforce will travel. The most relevant towns (indicated in yellow) are shown in Figure 13, and include Ashton, Bonnievale, De Doorns, Montagu, Robertson, Touws River, and Worcester.

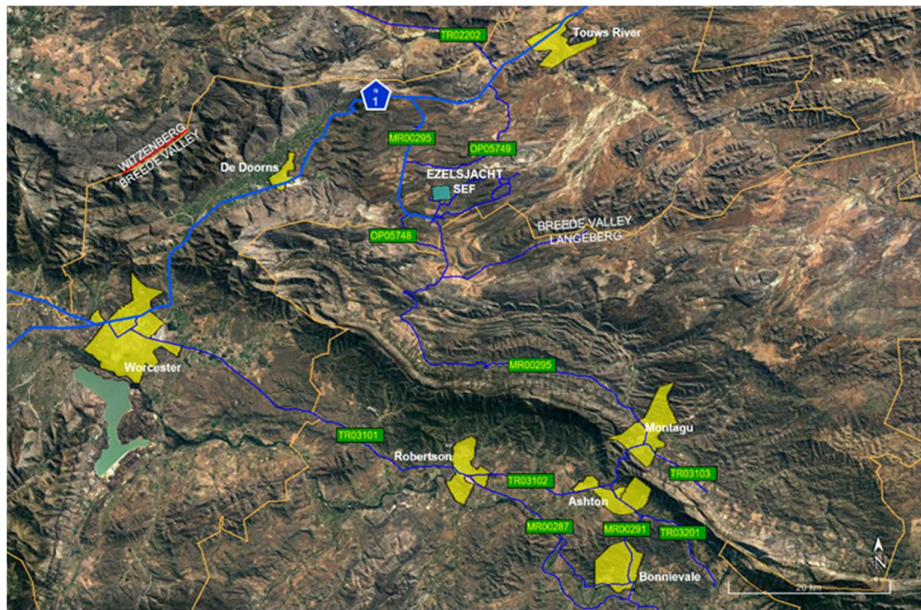

Figure 13 - Surrounding Towns

The personnel commuting to and from the proposed development will all travel on the MR 00295, personnel originating from Ashton, Bonnievale, Montagu, and Robertson will use the southern section of the MR 00295, while personnel originating from De Doorns, Touws River, and Worcester will use the northern section of the MR 00295.

The proportionality of the workforce from the surrounding communities is based on a 'working-age' population, modified by a 'weighting factor', calculated based on the distance travelled to the proposed development from the relevant town. The expected proportion of the workforce from the surrounding communities is depicted in Table 4.

Table 4 - Distribution of the Workforce

Town	Population	Travel Distance	Proportion (%)
Ashton	8739	73.2	6%
Bonnievale	5810	86.2	4%
De Doorns	7370	37.5	11%
Montagu	9895	62.4	9%
Robertson	18209	88.5	11%
Touwsriver	5120	36.6	8%
Worcester	66008	67.7	52%

6.3.2 Freight Routes

Container Terminals

Transnet Port Terminals operates container terminals at Durban, Ngqura, Gqeberha and Cape Town. Thus, all imported solar panel will enter South Africa via one of these terminals. The container terminal and the most likely routes to the proposed developments are as shown in Figure 14.



Figure 14 - Freight Routes - Port Terminals

The distance of the potential transportation routes from the various Container Terminals in South Africa to the proposed development, are detailed in Table 5.

Table 5 - Distance - Port Terminals

Container Terminals	Distance
Cape Town	177 km
Gqeberha (via N1)	746 km
Gqeberha (via N2)	667 km
Durban	1505

The closest container terminal to the proposed developments is from Cape Town.

However, the preferred transportation route would ultimately be identified by the logistic company appointed to transport the components from the port of entry to the proposed development

Commercial Centres

The most likely transportation routes for domestically supplied and manufactured components from the major commercial centres to the proposed developments are either Cape Town or Johannesburg (or any supplier along these routes), as shown in Figure 15.



Figure 15 - Freight Routes - Commercial Centres

The distances from the proposed developments to the major commercial centres in South Africa are shown in Table 6.

Table 6 - Distance - Major Commercial Centres

Commercial Centres	Distance
Cape Town	174 km
Johannesburg (via N1)	1266 km
Johannesburg (via N12)	1305 km

Although the closest major commercial centre to the proposed developments is located in the greater Cape Town area, many components will be fabricated in Johannesburg and transported to the proposed development.

6.4 RENEWABLE DEVELOPMENTS

According to the Screening Tool provided by SLR Consulting South Africa (Pty) Ltd, for the proposed developments, there are three renewable developments with an approved Environmental Authorisation or applications under consideration within 30 km of the proposed development, as listed in Table 7.

Table 7 - Surrounding Renewable Developments

No	EIA Reference No	Classification	Status of application	Distance (km)
1	14/12/16/3/3/2/810	Solar PV	Approved	13.1.km
2	12/12/20/1956	Solar PV	Approved	9.9.km
3	12/12/20/2210	Solar PV	Approved	14.4.km

These renewable projects (shown in red) plus the proposed Ezelsjacht developments are shown in Figure 16.

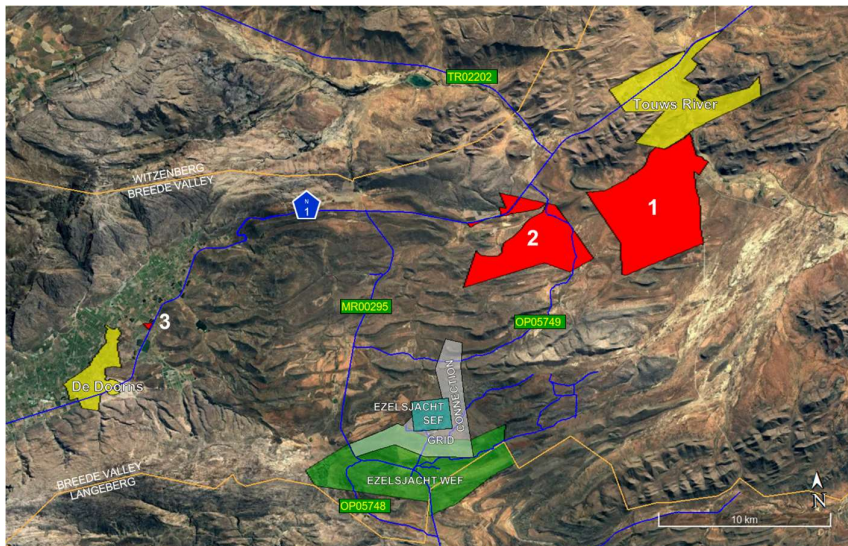

Figure 16 - Adjacent Proposed Renewable Energy Project

The other three renewable projects within the study area are all adjacent to the national road and will not contribute to the traffic load on MR 00295. The only projects that would directly impact the MR 00295, are the Ezelsjacht WEF, the Ezelsjacht SEF and associated infrastructure.

7 TRAFFIC VOLUMES

The South African Trip Data Manual (TMH 17), as provided by COTO, does not make provision for expected trip generation for the construction, operation and decommissioning phases of the renewable projects. Thus, the traffic trip generation for the construction, operation and decommissioning phrases used in this document is based on data provided by the client and obtained for similar projects. The estimated traffic generation detailed below represents a worst-case scenario.

7.1 STATUS QUO

The current traffic volume data on the public road network is obtained from counting stations and strip charts as provided by the Western Cape Road Information System.

7.1.1 Counting Stations

The counting stations on the road network adjacent to the proposed developments are shown in Figure 17.

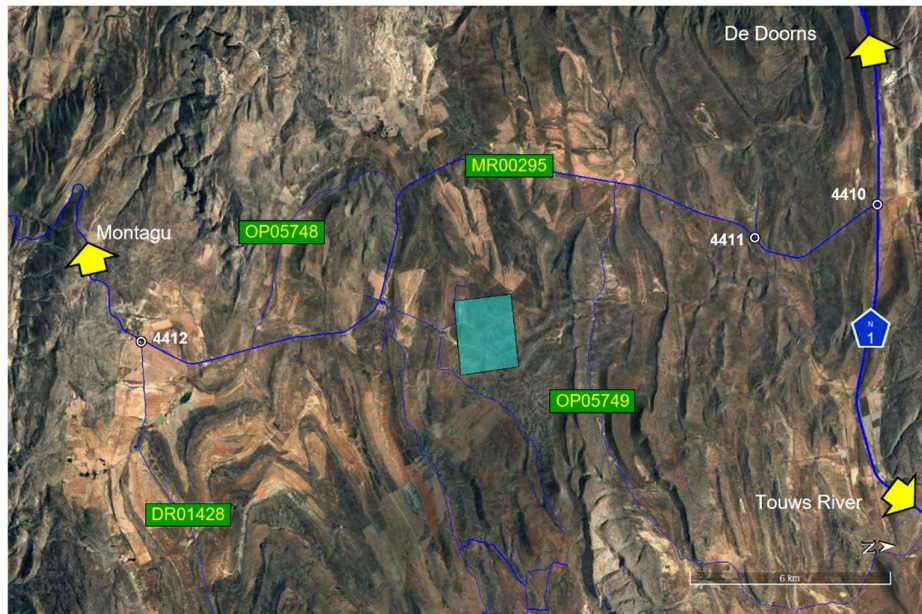

Figure 17 - Counting Station

Traffic volumes data on the roads within the study area was obtained from the Western Cape Government Road Network Information System, extracts of selected counting stations are delineated below.

The counting stations are normally located at junctions/intersections. The information extracted for each counting station includes the AADT, the split between light and heavy vehicles, as well as the intensity of the traffic during the day, per leg.

Counting Station 4410

The data for counting station 4410 is provided in Table 8.

Table 8 - Counting Station 4410

Counting Station Number: 4410					
Leg	Leg B	Leg C	Leg D		
AADT	3863	228	3863		
Light Traffic	48%	85%	48%		
Heavy Traffic	52%	15%	52%		
Station Count Chart for NR 00103				Station Count Chart for MR 00295	

The maximum hourly dual directional traffic on the NR 001 is in the order of 270 vph, assuming an equal split, there would be 135 vph in either direction, which peaks between 17:00 to 19:00. The maximum hourly dual directional traffic on the MR 295 is in the order of 24 vph.

Counting Station 4411

The data for counting station 4411 is provided in Table 9.

Table 9 - Counting Station 4411

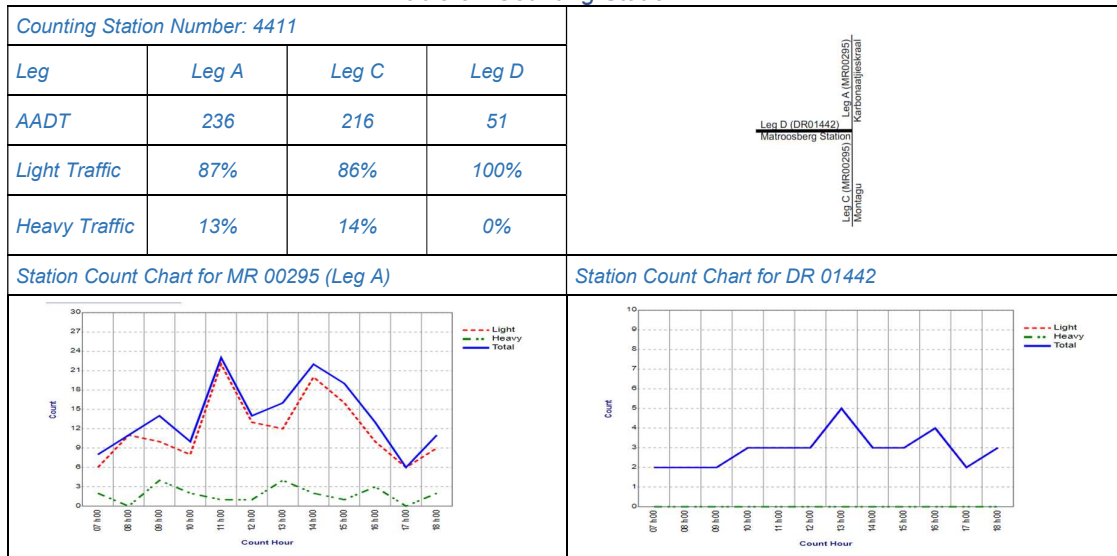

The maximum hourly dual directional traffic on the MR 295 (Leg A) is in the order of 24 vph, which peaks around 11:00.

Counting Station 4412

The data for counting station 4412 is provided in Table 10.

Table 10 - Counting Station 4412

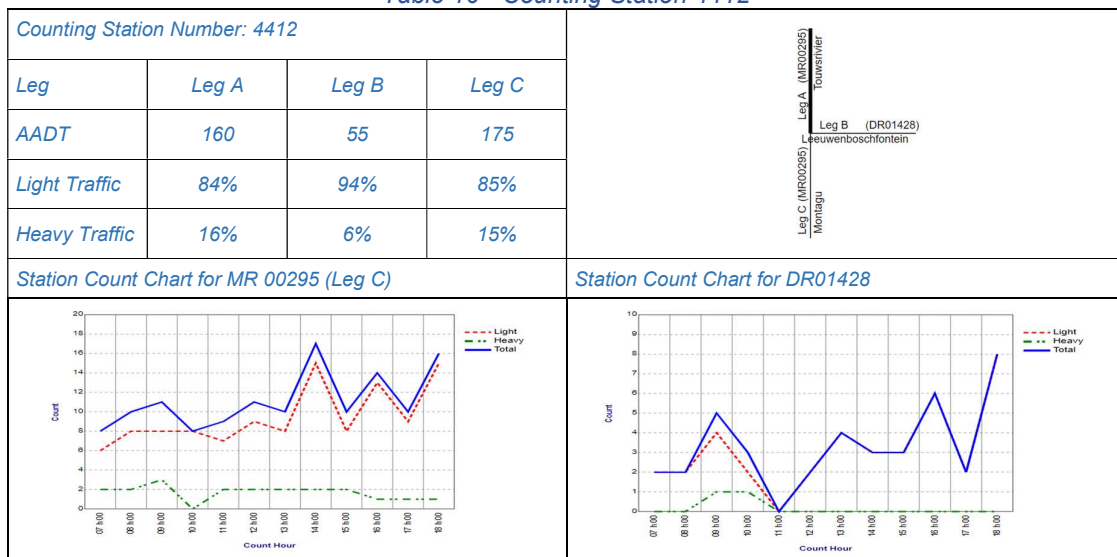

The maximum hourly dual directional traffic on the MR 295 (Leg C) is in the order of 17 vph.

7.1.2 Baseline Traffic Volumes

The baseline traffic volumes for the road network adjacent to the proposed developments are based on the AADT values obtained from the various counting stations. The values used are the average values between intersections, which have been adjusted by a growth factor relevant to the road. The adjusted AADT values used in this assessment are provided in Figure 18



Figure 18 - Baseline AADT

7.2 ROAD NETWORK MODEL

The road network adjacent to the proposed development has been comprehensively delineated in section 6.1 above.

A road network model, as shown in Figure 19, has been developed for analysis purposes and is the primary reference for the balance of this report.

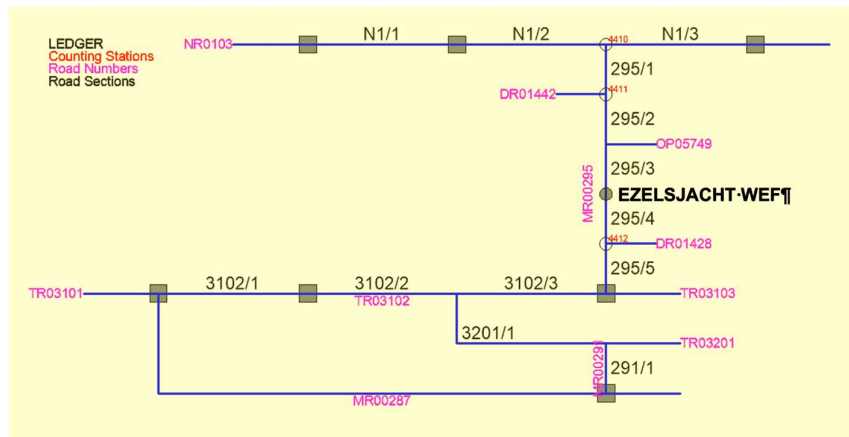

Figure 19 - Road Network Model

7.3 CONSTRUCTION PHASE

The construction phase of the proposed development will generate the most significant increase in traffic volumes on the local road network. Construction traffic will include vehicles transporting equipment, material and personnel. With the exception of the transformers and BESS equipment, there is no abnormal or oversized components are anticipated to be delivered to the proposed development.

A construction period of 24 months is anticipated for construction of the proposed development. The construction activities and duration will vary according to the construction schedule.

The two most significant activities, that impact traffic volumes during the construction phase, are:

- The commuting of personnel, to and from the proposed development; and
- The delivery of equipment and material to the proposed development.

The simultaneous occurrence of these two activities is improbable.

The commuting of personnel to and from the proposed development are two different activities, one occurring at the beginning of the working day (constituting the morning peak) and the other occurring at the end of the working day (constituting the afternoon peak). These activities contribute to Peak Traffic. Traffic movement statistics have shown a noticeable difference between morning and afternoon traffic peaks. Although the same number of trips are generated during these peaks, the morning peak is more concentrated, and the afternoon peak is spread over a longer period. Thus, for analysis purposes, the morning traffic shall be adopted for both morning and afternoon peaks to demonstrate a worst-case scenario.

The delivery of equipment and materials to the proposed developments is envisaged to occur during normal working hours throughout the day. No night deliveries are anticipated and are strongly discouraged. Given the distance from the origin of the material and components and the development, it is assumed that most deliveries will only start arriving at the proposed development an hour or two after work on site commences and will stop an hour or two before work on site concludes for the day. These activities contribute to Diurnal Traffic.

The envisaged timeframes for these activities, as adopted in this document, are:

- *Morning Peak Traffic - between 6:30 to 7:30;*
- *Diurnal Traffic - between 7:30 to 16:30;*
- *Afternoon Peak Traffic - between 16:30 to 17:30.*

7.3.1 Peak Traffic

It has been estimated that a total workforce complement of approximately 190 personnel will be required during the peak construction of the proposed developments. Since no accommodation is provided on-site, the personnel will have to be accommodated in the surrounding towns and commute to the proposed development. As identified in section 6.3.1, all the personnel on the proposed development will be drawn from surrounding towns.

Based on the project specification for the proposed development, the anticipated breakdown of the site personnel is as follows:

- *Senior Staff, consisting of Construction managers, supervisors and other key staff, constitute 10% of the site personnel, equating to approximately 15 persons. It is assumed that senior staff will reside within the community and will commute to the site, using double cab bakkies. A fleet of 11 vehicles is envisaged.*
- *The workforce, consisting of semi-skilled and unskilled workers, will constitute 90% of the site personnel, equating to 135 persons. It is assumed that the workforce will reside within the community and will commute to the site using approximately 9 various-size buses.*

It is assumed that the transport vehicles will remain on-site during the workday.

The maximum traffic volumes on the road network during the Peak Traffic of the proposed developments is depicted in Table 11.

Table 11 - Construction Phase - Peak Traffic

Road	Number of Vehicles
N1/1	6 vph
N1/2	7 vph
N1/3	4 vph
295/1	11 vph
295/2	11 vph
295/3	11 vph
295/4	9 vph
295/5	9 vph
3102/1	4 vph
3102/2	5 vph
3102/3	9 vph
3201/1	4 vph
291/1	4 vph

Based on the information provided above, the maximum number of vehicles on the public road network during Peak Traffic is in the order of 11 vph.

7.3.2 Diurnal Traffic

The construction phase of the proposed development consists of several activities, and some occur sequentially while others occur concurrently. Thus, not all the traffic volumes estimated in this document for the various activities are cumulative.

The envisaged construction phase activities, which will increase the traffic volumes include, inter alia:

- Site establishment: the initial activity of the development, the increase in traffic volumes resulting from this activity is not cumulative;
- Delivery of material and equipment to site: the traffic volumes resulting from these activities are cumulative and include the delivery of;
 - gravel for the construction of the roads, terraces, battery storage facility and substation platforms;
 - raw material (i.e. cement, sand, stone) for batching of concrete;
 - construction material (i.e. scaffolding, formwork, reinforcing steel, bricks, roof sheeting, fencing, etc.);
 - construction vehicles and equipment (i.e. earthmoving equipment, batching plant, etc.)
 - solar panels and structural steel components, this constitutes that most significant transportation for this project;
 - self-contained inverters and electrical cables;
 - substation components (i.e. steel gantries, transformers, switchgear, cables, circuit breakers, surge arresters, lightning conductor masts, etc.)
 - components for the battery storage facility (i.e. containers and equipment such as Lithium-ion batteries, inverters, transformers, HVAC equipment, switchgear, etc.)

Transportation of equipment and material to the proposed development is limited to the MR 00295, from both the north and south. However, the most likely route to be adopted for the delivery of equipment and material to the proposed development will be via the NR 001. The route via Montagu is less likely due to its location and the two passes en route.

The traffic volumes generated by the proposed development through the various construction activities are delineated below.

Construction Equipment and Materials

Once the site has been established, the delivery of construction equipment and materials will commence. Equipment, such as tools, machinery, scaffolding, formwork, etc., will be delivered to the proposed developments at the commencement of the construction and will be gradually removed from the proposed developments as construction draws to an end. Materials, such as reinforcing steel, brick, roof sheeting, fencing, transformers, switchgear, cables, etc., will be delivered to the proposed development as an ongoing activity. These deliveries will start increasing during the early stages of the construction phase, ramping up to maximum deliveries, before tapering off again close to the end of the construction phase

Various types of vehicles will be used to deliver the construction equipment and materials to the site. The increase in traffic volume for this activity is conservatively estimated to be in the order of eight return trips per day, which equates to approximately 2 vph.

Due to the size of the vehicles delivering the construction equipment and material, the most likely route for the majority of these deliveries to the proposed developments will be on the MR 00295 via the national road, although there is a slight chance that deliveries could use the southern portion of the MR 00295.

Earthworks

The construction of the sub-station platforms, battery storage area, and roads will be constructed from suitable gravels. To minimise the unnecessary importing of suitable material, cut and fill operations shall be adopted as far as possible for these elements.

However, provision has been made to source approximately 10 000 m³ of suitable material from commercial quarries outside the study area. The gravel is assumed to be delivered to the proposed developments in 20 m³ articulated rear tippers, over a period of 18 months. The increase in traffic volume for this activity is estimated to be in the order of 1.5 return trips per day, which equates to 0.35 vph.

This material could be delivered from either direction on the MR 00295, for calculation purposes both have been assumed.

Raw Material – Concrete

It is estimated that approximately 17 500 m³ of concrete will be mixed and placed on each of the proposed developments, over a period of 18 months. The majority will be for the securing the solar arrays, sub-stations and battery storage facilities.

It is envisaged that an on-site batching plant will be erected for the mixing of concrete for the development. The raw material for the concrete is to be delivered for the proposed development from commercial sources and includes 6 000 tonnes of cement, 10 500 m³ of sand, and 12 500 m³ of stone.

The increase in traffic volume resulting from this activity is estimated to be in the order of three return trips per day. Over an eight-hour day, this equates to 0.75 vph.

This material could be delivered from either direction on the MR 00295, for calculation purposes both have been assumed.

Solar Panels and Structural Steel

The proposed development has an anticipated generating capacity of 110 MW, based on technical information provided “Suntech”, it is envisaged that approximately

420 000 solar panel would be required. Assuming the panels and structural steel elements are delivered to site over a period of 18 months this would result in an increase in the traffic volume of approximately six return trips per day. Over an eight-hour day, this equates approximately 1.5 vph.

Due to the origin and size of the vehicles delivering the solar panels, the most likely route for these deliveries to the proposed development will be on the MR 00295 via NR 001.

Battery Energy Storage System

A Battery Energy Storage System (BESS) is to be constructed as part of the proposed development. The facility takes excess power generated by the wind farm, converts and stores it in batteries. The BESS technology may be either Lithium Ion or Redox Flow, as a worst-case in terms of deliveries, Lithium-Ion has been assumed. In this case, the BESS consists mainly of purpose-made steel containers, in which the batteries are stored and managed, together with inverters and transformers.

Since very little information is available regarding the number of trips generated for installing this equipment, the number of trips is based on how many containers can fit in the allocated area, considering fire and access requirements. Approximately 1 400 trips will be required over a period of five months. The increase in traffic volume resulting from this activity is estimated to be in the order of 14 return trips per day. Over an eight-hour day, this equates to approximately 3.5 vph.

These components will be transported to the proposed development on the MR 00295 via the national road.

Summary

Based on the above information, a summary of the expected Diurnal Traffic on the various roads for the proposed development is provided in Table 12.

Table 12 - Construction Phase - Diurnal Traffic

Road	Number of Vehicles
295/3 (North Bound)	6 vph
295/4 (South Bound)	1 vph

The information provided above is an informed estimate. Construction-related traffic may vary and be different from the information provided above due to the availability of contractors' resources and schedules.

7.4 OPERATIONAL PHASE

The operational life of the proposed development is expected to be approximately 20 years. The proposed development will operate (but not manned) on a 24-hour basis, except when there is a mechanical breakdown or maintenance activities.

The only on-site activities related to the proposed development will be the cleaning of the solar panels, monitoring, routine servicing, and unscheduled maintenance..

7.4.1 Peak Traffic

It is envisaged that the proposed developments are maintained and operated by a team of approximately 40 personnel.

Thus, the envisaged traffic volumes on the public road network for the proposed development are depicted in Table 13.

Table 13 - Operational Phase - Peak Traffic

Road	Number of Vehicles
N1/1	2 vph
N1/2	2 vph
N1/3	2 vph
295/1	4 vph
295/2	4 vph
295/3	4 vph
295/4	4 vph
295/5	4 vph
3102/1	2 vph
3102/2	2 vph
3102/3	4 vph
3201/1	2 vph
291/1	2 vph

Peak traffic is generated by commuting personnel to and from the proposed developments in the morning and afternoon. The maximum number of additional vehicles on the public road network is in the order of 4 vph.

7.4.2 Diurnal Traffic

Diurnal Traffic on the public roads as a result of the proposed development is limited to deliveries to and servicing of the proposed development, and daily site inspection activity.

The servicing, delivery of goods and visitors to the proposed developments are assumed to be in the order of two vehicles per day, servicing both proposed developments in a single trip. It is assumed that this traffic will travel to the proposed development from either De Doorns or Touws River.

Based on the information provided above, the maximum number of vehicles that could travel on the same section of the road (not necessary in the same direction), within any given hour, would be in the order of four.

Thus, the envisaged traffic volumes on the various public roads during the operational phase for the proposed developments are depicted in Table 15.

Table 14 - Operational Phase - Diurnal Traffic

Road	Number of Vehicles/Hour
295/3	4 vph
295/4	3 vph

Based on the information provided above, the maximum number of vehicles on the road network contributing to the Diurnal Traffic is anticipated to be in the order of 4 vph.

7.5 DECOMMISSIONING PHASE

At the end of the operational phase, the development may be decommissioned, or its continued economic viability may be investigated. If the development is still deemed economically viable, the development could be re-engineered, and the operational life may be extended. If the development is not financially viable, then the development shall be decommissioned. The components will be disassembled, reused, recycled or disposed of in accordance with the relevant regulatory requirements. The turbines may also be traded or sold as there is an active second-

hand market for wind turbines, or they may be used as scrap metal. The decommissioning procedures will be undertaken in line with an Environmental Management Programme, and the site will be rehabilitated and returned to its pre-construction state.

The decommissioning phase of the development is expected to create skilled and unskilled employment opportunities. The traffic impacts on the public roads during the decommissioning phase of the site will be significantly less than the traffic impact determined during the construction phase, as much of the internal infrastructures (i.e. roads, buildings, etc.) will be retained by the landowners.

As part of the decommissioning process, a separate traffic impact assessment should be undertaken since many of the characteristics related to the traffic impact assessment, i.e. access routes, road geometry, traffic volumes, etc., would have changed over the operational life of the development. Thus, a specific decommissioning assessment has not been included in this report.

8 ASSESSMENT OF IMPACTS

As described in section 6.2, the proposed development is accessed from the MR 00295, either from the north (via the NR 001) or the south (via Montagu).

It is envisaged that most of the deliveries from the commercial centres in South Africa will be via the NR 001. It is possible that smaller deliveries of sand, stone and cement could be delivered from the south, depending on the source of the material. Although all deliveries via Montagu would have to traverse the Rooihogte and Burger Passes.

8.1 CONSTRUCTION PHASE

The duration of the active construction phase is estimated to be in the order of 24 months. During the construction phase, traffic will be generated through two distinct sources:

- The commuter traffic, getting personnel to and from the proposed development (Peak Traffic); and
- The freight traffic, the delivery of materials and equipment to the proposed development (Diurnal Traffic).

It is envisaged that the transportation of the site personnel will result in Peak Traffic, while the delivery of equipment and materials to the site will be distributed throughout the day.

The traffic volumes generated, for both Peak Traffic and Diurnal Traffic, resulting from the proposed development have been addressed in Section 7. Thus, the combined expected increase in the traffic volumes on the road network during the peak construction phase of the proposed developments is summarised in Table 15.

Table 15 - Construction Phase - Traffic Volumes

Roads	Day (divided into three-time frames)						
	06:30	Morning Peak Traffic (vph)	07:30	Diurnal Traffic (vph)	16:30	Afternoon Peak Traffic (vph)	17:30
N1/1		6 vph		4 vph		6 vph	
N1/2		7 vph		4 vph		7 vph	
N1/3		4 vph		5 vph		4 vph	
295/1		11 vph		5 vph		11 vph	
295/2		11 vph		6 vph		11 vph	

Roads	Day (divided into three-time frames)						
	06:30	Morning Peak Traffic (vph)	07:30	Diurnal Traffic (vph)	16:30	Afternoon Peak Traffic (vph)	17:30
295/3		11 vph		6 vph		11 vph	
295/4		9 vph		1 vph		9 vph	
295/5		9 vph		1 vph		9 vph	
3102/1		4 vph		1 vph		4 vph	
3102/2		5 vph		1 vph		5 vph	
3102/3		9 vph		1 vph		9 vph	
3201/1		4 vph		1 vph		4 vph	
291/1		4 vph		1 vph		4 vph	

Based on the information provided in the table above, no traffic volumes are increased by more than 50 trips per hour, for the proposed development. Thus negating the requirement for a TIA as specified in section 2.6 of the "South African Traffic Impact and Site Traffic Assessment Manual", which reads as follows; "A Traffic Impact Assessment shall be undertaken and submitted when an application is made for a change in land use and when the highest total additional hourly vehicular trip generation (including pass-by and diverted trips) as a result of the application exceeds 50 trips per hour".

Traffic volume generated during the peak construction phase of the proposed developments is in the order of:

- **Peak Traffic:** The maximum number of vehicles on the road network within a given hour is estimated to be in the order of 11 vph.
- **Diurnal Traffic:** The maximum number of vehicles on the road network within a given hour is estimated to be in the order of 6 vph. Which equates to approximately 48 vehicles, over an eight-hour period.

The ADT generated during the peak construction phase on the roads, expressed as an "Increased ADT", is shown in Table 16.

Table 16 - Construction Phase - Traffic Assessment

Road	ADT Baseline*	Additional Traffic Generated**	Increased ADT
N1/1	3863 vpd	(12+32) = 44 vpd	3907 vpd
N1/2	3863 vpd	(14+32) = 46 vpd	3909 vpd
N1/3	3862 vpd	(8+40) = 48 vpd	3910 vpd
295/1	241 vpd	(22+40) = 62 vpd	303 vpd
295/2	192 vpd	(22+48) = 70 vpd	262 vpd
295/3	192 vpd	(22+48) = 70 vpd	262 vpd
295/4	192 vpd	(18+8) = 26 vpd	218 vpd
295/5	166 vpd	(18+8) = 26 vpd	192 vpd
3102/1	7899 vpd	(8+8) = 16 vpd	7915 vpd
3102/2	9361 vpd	(10+8) = 18 vpd	9379 vpd
3102/3	4787 vpd	(18+8) = 26 vpd	4813 vpd
3201/1	4820 vpd	(8+8) = 16 vpd	4836 vpd
291/1	1295 vpd	(8+8) = 16 vpd	1311 vpd

* Average AADT as defined by the Strip Charts

** The first value represents the Peak Traffic and the second value represents the Diurnal Traffic

The most significant increase in traffic is on roads 295/2 and 295/3, which increases the Baseline ADT from 192 vpd to 262 vpd, an increase of 36%, in both directions. Based on a speed of 100 km/h, the traffic volume will result in a Following Density of

0.16 v/km, equating to one vehicle every 3.75 minutes, resulting in an acceptable Level of Service (LOS A).

The additional traffic volumes on the road network, does not compromise the level of service for these roads. Thus, even when the additional worst-case traffic volumes are applied, the traffic density of the road network is deemed acceptable.

8.2 OPERATIONAL PHASE

The duration of the operational phase of the proposed development, which is estimated to be in the order of 20 years, traffic will be generated through two distinct sources:

- The commuter traffic, getting personnel to and from the proposed developments (Peak Traffic); and
- The daily inspections, periodical maintenance, delivery of goods and servicing of the proposed developments (Diurnal Traffic).

It is envisaged that the transportation of the site personnel will result in Peak Traffic, while daily inspections, periodical maintenance, delivery of goods and servicing of the proposed developments will be distributed throughout the day.

The traffic volumes generated, for both Peak Traffic and Diurnal Traffic, resulting from both the proposed development's operational phases, have been addressed in Section 7. Thus, the expected increase in the traffic volumes on the various roads during the operational phase of the proposed developments is summarised in Table 17.

Table 17 - Operational Phase - Traffic Volumes

Roads	Day (divided into three-time frames)						
	06:30	Morning Peak Traffic (vph)	07:30	Diurnal Traffic (vph)	16:30	Afternoon Peak Traffic (vph)	17:30
N1/1		2 vph		4 vph		2 vph	
N1/2		2 vph		4 vph		2 vph	
N1/3		2 vph		4 vph		2 vph	
295/1		4 vph		4 vph		4 vph	
295/2		4 vph		4 vph		4 vph	
295/3		4 vph		4 vph		4 vph	
295/4		4 vph		3 vph		4 vph	
295/5		4 vph		3 vph		4 vph	
3102/1		2 vph		3 vph		2 vph	
3102/2		2 vph		3 vph		2 vph	
3102/3		4 vph		3 vph		4 vph	
3201/1		2 vph		3 vph		2 vph	
291/1		2 vph		3 vph		2 vph	

Based on the information provided in the table above, there are no traffic volumes that are increased by more than 50 trips an hour, thus negating the requirement for a TIA as specified in section 2.6 of the "South African Traffic Impact and Site Traffic Assessment Manual", which reads as follows; "A Traffic Impact Assessment shall be undertaken and submitted when an application is made for a change in land use and when the highest total additional hourly vehicular trip generation (including pass-by and diverted trips) as a result of the application exceeds 50 trips per hour".

The traffic volume generated during the operational phase of the proposed development is as follows:

- *Peak Traffic:* The maximum number of vehicles on the road network within a given hour is estimated to be in the order of 4 vph.
- *Diurnal Traffic:* The maximum number of vehicles on the road network within a given hour is estimated to be in the order of 4 vph.

The ADT generated during the operational phase of the proposed development on the public road network, expressed as an "Increased ADT", is shown in Table 18.

Table 18 - Operational Phase - Traffic Assessment

Road	ADT Baseline*	Additional Traffic Generated**	Increased ADT
N1/1	3863 vpd	(4+32) = 36 vpd	3899 vpd
N1/2	3863 vpd	(4+32) = 36 vpd	3899 vpd
N1/3	3862 vpd	(4+32) = 36 vpd	3898 vpd
295/1	241 vpd	(8+32) = 40 vpd	281 vpd
295/2	192 vpd	(8+32) = 40 vpd	232 vpd
295/3	192 vpd	(8+32) = 40 vpd	232 vpd
295/4	192 vpd	(8+24) = 32 vpd	224 vpd
295/5	166 vpd	(8+24) = 32 vpd	198 vpd
3102/1	7899 vpd	(4+24) = 28 vpd	7927 vpd
3102/2	9361 vpd	(4+24) = 28 vpd	9389 vpd
3102/3	4787 vpd	(8+24) = 32 vpd	4819 vpd
3201/1	4820 vpd	(4+24) = 28 vpd	4848 vpd
291/1	1295 vpd	(4+24) = 28 vpd	1323 vpd

* Average AADT of the legs along the section of road

** The first value represents the Peak Traffic and the second value represents the Diurnal Traffic

The most significant increase in traffic is on roads 295/2 and 295/3, which increases the Baseline ADT from 192 vpd to 232 vpd, an increase of less than 21%, in both directions. Based on a speed of 100 km/h, the traffic volume will result in a Following Density of 0.15 v/km, equating to one vehicle every 4 minutes, resulting in an acceptable Level of Service (LOS A).

The additional traffic volumes on the road network, does not compromise the level of service for these roads. Thus, even when the additional worst-case traffic volumes are applied, the traffic density of the road network is deemed acceptable.

8.3 DECOMMISSIONING PHASE

As described in Section 7.4 above, a separate traffic impact assessment should be undertaken as part of the decommissioning process since many of the characteristics related to the traffic impact assessment, i.e. access routes, road geometry, traffic volumes, etc., would have changed over the operational life of the development. Thus, no traffic assessment for the decommissioning phase has been undertaken in this report.

9 ASSESSMENT OF CUMULATIVE IMPACTS

The assessment of the traffic volumes on the road network within the study area resulting from the cumulative renewable developments during the construction, operational and decommissioning phases of the proposed development are delineated below.

The extent of the known renewable energy projects earmarked within a 30 km radius of the proposed developments has been defined in Section 6.4.

The only renewable project within the study area that utilises the same public road network as the proposed development will be the Ezelsjacht SEF. Which, this report will be assumed to be constructed simultaneously with the proposed development, resulting in a worst-case scenario.

9.1 CONSTRUCTION PHASE

The cumulative traffic volumes on the road network within the study area result from the simultaneous construction of the Ezelsjacht WEF, Ezelsjacht SEF Facility, and associated infrastructure.

The peak traffic volumes are based on a combined workforce complement of 550 has been assumed, which includes the construction of the BESS, Substations and Grid Connection.

Thus, the cumulative traffic volumes, for both Peak and Diurnal Traffic, on the public road network for the project identified above are provided in Table 19.

Table 19 - Cumulative Constructional Phase - Traffic Volume

Roads	Day (divided into three-time frames)						
	06:30	Morning Peak Traffic (vph)	07:30	Diurnal Traffic (vph)	16:30	Afternoon Peak Traffic (vph)	17:30
N1/1		17 vph		15 vph		17 vph	
N1/2		19 vph		15 vph		19 vph	
N1/3		10 vph		15 vph		10 vph	
295/1		29 vph		15 vph		29 vph	
295/2		29 vph		15 vph		29 vph	
295/3		29 vph		15 vph		29 vph	
295/4		22 vph		6 vph		22 vph	
295/5		22 vph		6 vph		22 vph	
3102/1		10 vph		6 vph		10 vph	
3102/2		12 vph		6 vph		12 vph	
3102/3		22 vph		6 vph		22 vph	
3201/1		10 vph		6 vph		10 vph	
291/1		10 vph		6 vph		10 vph	

Based on the information provided in the table above, there are no traffic volumes that are increased by more than 50 trips an hour, thus negating the requirement of a TIA, as per section 2.6 of the "South African Traffic Impact and Site Traffic Assessment Manual", which reads as follows; "A Traffic Impact Assessment shall be undertaken and submitted when an application is made for a change in land use and when the highest total additional hourly vehicular trip generation (including pass-by and diverted trips) as a result of the application exceeds 50 trips per hour".

The maximum cumulative traffic volumes generated on the various roads during the construction phase of the proposed Ezelsjacht WEF and Ezelsjacht SEF are in the order:

- **Peak Traffic:** The maximum number of vehicles on any one section of the public road network within a given hour is estimated to be in the order of 29 vph.
- **Diurnal Traffic:** The maximum number of vehicles on the road network within a given hour is estimated to be in the order of 15 vph. Which equates to approximately 120 vehicles, over an eight-hour period.

The assessment of the cumulative traffic impact generated during the peak construction phase expressed as an "Increased ADT" is provided in Table 20.

Table 20 - Cumulative Constructional Phase - Traffic Assessment

Road	ADT Baseline*	Additional Traffic Generated**	Increased ADT
N1/1	3863 vpd	(34+120) = 154 vpd	4017 vpd
N1/2	3863 vpd	(38+120) = 158 vpd	4021 vpd
N1/3	3862 vpd	(20+120) = 140 vpd	4002 vpd
295/1	241 vpd	(58+120) = 178 vpd	419 vpd
295/2	192 vpd	(58+120) = 178 vpd	370 vpd
295/3	192 vpd	(58+120) = 178 vpd	370 vpd
295/4	192 vpd	(44+48) = 92 vpd	284 vpd
295/5	166 vpd	(44+48) = 92 vpd	258 vpd
3102/1	7899 vpd	(20+48) = 68 vpd	7967 vpd
3102/2	9361 vpd	(24+48) = 72 vpd	9433 vpd
3102/3	4787 vpd	(44+48) = 92 vpd	4879 vpd
3201/1	4820 vpd	(20+48) = 68 vpd	4888 vpd
291/1	1295 vpd	(20+48) = 68 vpd	1363 vpd

* Average AADT of the legs along the section of road

** The first value represents the Peak Traffic and the second value represents the Diurnal Traffic

The most significant increase in traffic is on roads 295/2 and 295/3, which increases the Baseline ADT from 192 vpd to 370 vpd, an increase of less than 93%, in both directions. Based on a speed of 100 km/h, the traffic volume will result in a Following Density of 0.23 v/km, equating to one vehicle every 2.6 minutes, resulting in an acceptable Level of Service (LOS A).

The additional traffic volumes on the road network, does not compromise the level of service for these roads. Thus, even when the additional worst-case traffic volumes are applied, the traffic density of the road network is deemed acceptable.

9.2 OPERATIONAL PHASE

The Peak and Diurnal cumulative traffic volumes on the road network related to the operational phase of the proposed Ezelsjacht WEF and Ezelsjacht SEF developments, based on a combined workforce of 80 individuals, are provided in Table 21.

Table 21 - Cumulative Operational Phase - Traffic Volumes

Roads	Day (divided into three-time frames)						
	06:30	Morning Peak Traffic (vph)	07:30	Diurnal Traffic (vph)	16:30	Afternoon Peak Traffic (vph)	17:30
N1/1		4 vph		8 vph		4 vph	
N1/2		4 vph		8 vph		4 vph	
N1/3		4 vph		8 vph		4 vph	
295/1		8 vph		8 vph		8 vph	
295/2		8 vph		8 vph		8 vph	
295/3		8 vph		8 vph		8 vph	
295/4		8 vph		6 vph		8 vph	
295/5		8 vph		6 vph		8 vph	
3102/1		4 vph		6 vph		4 vph	
3102/2		4 vph		6 vph		4 vph	
3102/3		8 vph		6 vph		8 vph	
3201/1		4 vph		6 vph		4 vph	
291/1		4 vph		6 vph		4 vph	

Based on the information provided in the table above, there are no traffic volumes that are increased by more than 50 trips an hour, thus negating the requirement for a

TIA as specified in section 2.6 of the "South African Traffic Impact and Site Traffic Assessment Manual", "A Traffic Impact Assessment shall be undertaken and submitted when an application is made for a change in land use and when the highest total additional hourly vehicular trip generation (including pass-by and diverted trips) as a result of the application exceeds 50 trips per hour".

The cumulative traffic volumes generated on the road network within the study area during the combined operational phase of the proposed Ezelsjacht WEF and Ezelsjacht SEF developments are in the order:

- **Peak Traffic:** The maximum number of vehicles on the road network within a given hour is estimated to be in the order of 8 vph;
- **Diurnal Traffic:** The maximum number of vehicles on the road network within a given hour is estimated to be in the order of 8 vph.

The assessment of the cumulative traffic impact generated during the operational phase expressed as an "Increased ADT" is provided in Table 22.

Table 22 - Cumulative Operational Phase - Traffic Assessment

Road	ADT Baseline*	Additional Traffic Generated**	Increased ADT
N1/1	3863 vpd	(8+64) = 72 vpd	3935 vpd
N1/2	3863 vpd	(8+64) = 72 vpd	3935 vpd
N1/3	3862 vpd	(8+64) = 72 vpd	3934 vpd
295/1	241 vpd	(16+64) = 80 vpd	321 vpd
295/2	192 vpd	(16+64) = 80 vpd	272 vpd
295/3	192 vpd	(16+64) = 80 vpd	272 vpd
295/4	192 vpd	(16+48) = 64 vpd	256 vpd
295/5	166 vpd	(16+48) = 64 vpd	230 vpd
3102/1	7899 vpd	(8+48) = 56 vpd	7955 vpd
3102/2	9361 vpd	(8+48) = 56 vpd	9417 vpd
3102/3	4787 vpd	(16+48) = 64 vpd	4851 vpd
3201/1	4820 vpd	(8+48) = 56 vpd	4876 vpd
291/1	1295 vpd	(8+48) = 56 vpd	1351 vpd

* Average AADT of the legs along the section of road

** The first value represents the Peak Traffic and the second value represents the Diurnal Traffic

The most significant increase in traffic is on roads 295/2 and 295/3, which increases the Baseline ADT from 192 vpd to 272 vpd, an increase of less than 42%, in both directions. Based on a speed of 100 km/h, the traffic volume will result in a Following Density of 0.17 v/km, equating to one vehicle every 3.5 minutes, resulting in an acceptable Level of Service (LOS A).

The additional traffic volumes on the road network, does not compromise the level of service for these roads. Thus, even when the additional worst-case traffic volumes are applied, the traffic density of the road network is deemed acceptable.

9.3 DECOMMISSIONING PHASE

As described in Section 7.4 above, a separate traffic impact assessment should be undertaken as part of the decommissioning process since many of the characteristics related to the traffic impact assessment, i.e. access routes, road geometry, traffic volumes, etc., would have changed over the operational life of the developments. Thus, no cumulative traffic assessment for the decommissioning phase has been undertaken in this report.

10 RISKS AND IMPACTS

Developments within an established environment can cause a significant impact on the road network, mainly when new developments are introduced into the environment, which leads to an increase in traffic on the existing public roads. The traffic volume will vary depending on the phase of the development. More traffic is envisaged during the construction and decommissioning phases of the proposed developments, while traffic volumes during the operational phase of the proposed developments are deemed insignificant.

With the increase in traffic on the roads comes the potential increase in incidents. The incidents could vary from minor damage to the vehicle due to the road conditions to fatal collisions with other vehicles, pedestrians or even animals.

Traffic safety is directly related to the attitude of the drivers using the roads. The road condition will dictate the safe speed limit a responsible driver will travel. However, not all road users are responsible, resulting in frustrated drivers taking unnecessary chances, many of which involve excessive speeding.

Thus, to improve traffic safety on the roads, it is strongly suggested that all key personnel, including mini-bus and bus drivers, be provided with advanced driver training.

10.1 RISKS

The existing road network has numerous intrinsic risks, which could be exacerbated by the traffic generated due to the development. The most pertinent risks are briefly discussed below and need to be considered by the developer during the various phases of the proposed developments.

10.1.1 Traffic Volumes

The traffic volumes on the road network will be significantly more during the construction phase than expected during the proposed developments' operational phase.

Traffic congestion and delays caused by long slow-moving convoys of delivery vehicles are concerns that needed to be addressed and managed by the logistics contractor appointed to transport the equipment to the site.

During the construction phase of the proposed developments, a significant increase in traffic is anticipated during the morning and afternoon peaks. The diurnal traffic related to this development is less significant as it is spread over the entire day.

During the operational phase of the development, there will be a nominal increase in traffic on the local road network. The increase in traffic volumes will be limited to peak traffic with negligible diurnal traffic generated.

The increased traffic volumes will increase the potential of incidents on the roads within the study area, specifically at intersections and through urban areas.

A Traffic Management Plan will need to be compiled to identify and manage mitigation measures for the construction phase of the proposed development, refer to Section 11 for more detail.

10.1.2 Road Condition

All the roads in the study area are paved and in fair to good condition.

During the construction phase of the proposed developments, there will be an increase in the traffic volumes on the local road network. The increased traffic volumes will place an additional burden on the roads within the study area. The movement of concrete delivery trucks used during the casting of the WTG foundation on the public road network immediately adjacent to the proposed developments is an issue that will need to be addressed.

Mitigation of this impact is regular maintenance of the roads by the local road authorities. As is standard practice and customarily enforced as part of the planning approval for the development, the developer undertakes to contribute towards or conducts regular maintenance of the road network used by the developer.

However, maintenance of the internal road network will be the responsibility of the contractors.

10.1.3 Reduced Visibility

Numerous natural phenomena could compromise the road user's visibility, thus increasing the road network's potential for accidents. These include inter alia:

- Sun glare: When driving on the road into the sun, there is a high probability of being blinded by the sun, and not being able to observe activities along the road and intersections, which could result in an incident;*
- Inclement weather (including mist and fog): Visibility is the primary concern when driving in inclement weather. Reduced visibility resulting from either the rain itself or from the spray of the vehicles travelling on the road. Skidding and aquaplaning resulting from water on the road surface is a probable risk;*
- Dust: The generation of dust when travelling on unpaved roads is inevitable. The larger the vehicle, the more dust is generated. This dust hinders the drivers wishing to overtake with a clear view for overtaking, resulting in drivers taking unnecessary chances, with unfavourable consequences.*

Mitigation measures to consider include

- Compile a Traffic Management Plan, sections of which are to be part of induction training for all personnel travelling to the development during the construction phase.*

10.1.4 Pedestrians and Animals

The development is to be constructed in a rural area, including mountainous terrain. Large portions of the area are undeveloped and are home to various species of antelope.

If the roads pass through homesteads on routes to the proposed developments, this is a safety concern that will need to be addressed by the contractor. Drivers need to be aware of the importance of reducing speed when approaching and passing through these establishments.

Stray livestock, wild animals and pedestrians are all potential risks to road users. If drivers take evasive action at high speed, there is a strong probability that the vehicle could roll, resulting in severe injuries or even fatalities. Failing to take evasive action will result in the inevitable fatality of the animal or pedestrian.

During all phases of the project, mitigation measures are limited to providing drivers with advanced driver training and training on how to handle a vehicle in the event of

a tire blow-out or an antelope jumping into the road, as the incorrect evasive action could have dire consequences.

10.2 IMPACTS

The road network within the study area is limited, offering very little opportunity of selecting alternative routes. All routes evaluated for the development are existing roads, and no new roads need to be constructed. However, remedial action at various intersections along the transportation routes might be required before the transportation of equipment and material to the site can commence.

Traffic-related risks and impacts on the road network within the study area have been assessed using an assessment methodology provided by SLR Consulting South Africa (Pty) Ltd for various phases of this development.

10.2.1 Construction Phase

During the peak construction phase of the development, the following safety and road network integrity impacts have been assessed.

Increased Traffic Volume

The impact of increased traffic volumes on public roads, which will cause congestion and increase the potential of incidents on the road network within the study area, is provided in Table 23.

Table 23 - Construction Phase - Increased Road Incidents

Issue	Increased Traffic Volume	
Description of Impact		
The increased traffic volumes on the public roads will cause congestion and increase the potential of incidents on the road network within the study area		
Type of Impact	Indirect	
Nature of Impact	Negative	
Phases	Construction	
Criteria	Without Mitigation	With Mitigation
Intensity	Very High	Very High
Duration	Short-term	Short-term
Extent	Regional	Regional
Consequence	Medium	Medium
Probability	Conceivable	Conceivable
Significance	Medium -	Medium -
Degree to which impact can be reversed	The resource (a person's life) is irreparably damaged and is not represented elsewhere	
Degree to which impact may cause irreplaceable loss of resources	The resource (a person's life) is irreparably damaged and is not represented elsewhere	
Degree to which impact can be mitigated	Mitigation does not exist, or mitigation will slightly reduce the significance of impacts	
Mitigation actions		
The following measures are recommended:	Post relevant road signage along affected routes; Create a local WhatsApp Group, notifying users of expected deliveries and proposing alternative routes; Traffic Management Plan, this is to be compiled once the contractor has been appointed and all the relevant details of the construction process are known. The TMP needs to address, inter alia: - schedule delivery to avoid local congestion - define the preferred route for the delivery of all equipment and material Ensure all vehicles are roadworthy, visible, properly marked, and operated by an appropriately licenced operator. Provide drivers with advanced driver training	

	The developer shall implement the necessary steps to protect the pedestrians and livestock on the roads, specifically where the roads pass through farming homesteads, as these are a serious safety concern	
Monitoring		
The following monitoring is recommended:	Incident register and ongoing road safety awareness training	
Cumulative impacts		
Nature of cumulative impacts	The cumulative impact resulting from the traffic volumes on the road network	
Rating of cumulative impacts	Without Mitigation	With Mitigation
	Medium -	Medium -

Road Degradation

The impact of increased traffic volumes on public roads, which will increase the potential for localised road network degradation within the study area, is presented in Table 24.

Table 24 - Construction Phase - Road Degradation

Issue	Road Degradation	
Description of Impact		
The increased traffic volumes on public roads will increase the potential for localised road network degradation within the study area.		
Type of Impact	Indirect	
Nature of Impact	Negative	
Phases	Construction	
Criteria	Without Mitigation	With Mitigation
Intensity	Medium	Low
Duration	Short-term	Short-term
Extent	Local	Local
Consequence	Medium	Medium
Probability	Definite / Continuous	Conceivable
Significance	Medium -	Low -
Degree to which impact can be reversed	The affected environment will be able to recover from the impact	
Degree to which impact may cause irreplaceable loss of resources	The resource is not damaged irreparably or is not scarce	
Degree to which impact can be mitigated	Mitigation exists and will notably reduce the significance of impacts	
Mitigation actions		
The following measures are recommended:	Create a local WhatsApp Group for the local community and post notices of road conditions and proposed alternatives. Developer to contribute to the maintenance of the public roads in the area during the construction phase of the development/s. A photographic record of the road condition should be maintained throughout the various phases of the development/s. This provides an objective assessment and mitigates any subjective views from road users. Upgrade unpaved roads to a suitable condition for proposed construction vehicles; Ensure that the roads are left in the same or better condition, post-construction.	
Monitoring		
The following monitoring is recommended:	Weekly inspection,	
Cumulative impacts		
Nature of cumulative impacts	The cumulative impact resulting from the traffic volumes on the road network	
Rating of cumulative impacts	Without Mitigation	With Mitigation
	Medium -	Low -

Dust

The larger the vehicle, the more dust is likely to be generated. This dust hinders the drivers wishing to overtake without a clear view for overtaking, resulting in drivers

taking unnecessary chances, which could result in unfavourable consequences. The impact of increased traffic volumes on the unpaved public roads that will generate dust is presented in Table 25.

Table 25 - Construction Phase – Dust

Issue	Dust	
Description of Impact		
The increased traffic volumes on unpaved public roads will generate more dust. The larger the vehicle, the more dust is likely to be generated. This dust hinders the drivers wishing to over-take without a clear view of over-taking, resulting in drivers taking unnecessary chances, which could result in unfavourable consequences		
Type of Impact	Indirect	
Nature of Impact	Negative	
Phases	Construction	
Criteria	Without Mitigation	With Mitigation
Intensity	High	High
Duration	Medium-term	Short-term
Extent	Regional	Regional
Consequence	High	Medium
Probability	Possible / frequent	Conceivable
Significance	Medium -	Low -
Degree to which impact can be reversed	The affected environment will not be able to recover from the impact - permanently modified	
Degree to which impact may cause irreplaceable loss of resources	The resource is irreparably damaged and is not represented elsewhere	
Degree to which impact can be mitigated	Mitigation does not exist, or mitigation will slightly reduce the significance of impacts	
Mitigation actions		
The following measures are recommended:	Reduce travel speed for construction vehicles on the gravel road to reduce dust Dust suppression of the roads in the immediate vicinity of the site where feasible Regular preventative maintenance of roads within the immediate vicinity of the site should be conducted over weekends to minimise the impact on the average construction period.	
Monitoring		
The following monitoring is recommended:	Continues observation, and remedial action needs to be taken as and when required	
Cumulative impacts		
Nature of cumulative impacts	The cumulative impact resulting from the traffic volumes on the road network	
Rating of cumulative impacts	Without Mitigation	With Mitigation
	Medium -	Low -

Intersection Safety

The impact due to the increased traffic volumes at intersections, which will increase the potential risk of accidents at the intersections, resulting in serious injuries or even fatalities, is presented in Table 26, especially at the intersection on the main roads, when vehicles from the site needing to cross over oncoming traffic.

Table 26 - Construction Phase - Intersection Safety

Issue	Intersection Safety	
Description of Impact		
The increased traffic volumes at intersections will increase the potential risk of accidents at the intersections, resulting in serious injuries or even fatalities, especially at the intersection on the main roads, when vehicles from the site need to cross over oncoming traffic.		
Type of Impact	Indirect	
Nature of Impact	Negative	
Phases	Construction	
Criteria	Without Mitigation	With Mitigation

Intensity	High	High
Duration	Short-term	Short-term
Extent	Site	Site
Consequence	Medium	Medium
Probability	Definite / Continuous	Definite / Continuous
Significance	Medium -	Medium -
Degree to which impact can be reversed	The affected environment will not be able to recover from the impact - permanently modified	
Degree to which impact may cause irreplaceable loss of resources	The resource is irreparably damaged and is not represented elsewhere	
Degree to which impact can be mitigated	Mitigation exists and will notably reduce the significance of impacts	
Mitigation actions		
The following measures are recommended:	Compile TMP, refer to Section 11 of the Traffic Report. Reduce speed at intersections and use appropriate traffic warning signs Identify alternative routes where possible Request the assistance of local law enforcement Ensure that all construction vehicles are roadworthy, visible, adequately marked, and operated by an appropriately licenced operator.	
Monitoring		
The following monitoring is recommended:	Incident register and ongoing road safety awareness training	
Cumulative impacts		
Nature of cumulative impacts	The cumulative impact is due to the increased traffic volumes at intersections, which will increase the potential risk of accidents at the intersections, resulting in serious injuries or even fatalities, especially at the intersection on the main roads, when vehicles from the site need to cross over oncoming traffic.	
Rating of cumulative impacts	Without Mitigation	With Mitigation
	Medium -	Medium -

10.2.2 Operational Phase

During the operational phase of the development, the traffic volumes are considerably less than during the construction phase of the proposed development. Thus all impacts associated with increased traffic volumes have been omitted. Therefore, the only impact deemed essential during the operational phase of the proposed development is addressed below.

Intersection Safety

The cumulative impact due to the increased traffic volumes at intersections, which will increase the potential risk of accidents at the intersections, resulting in serious injuries or even fatalities, is presented in Table 27, especially at the intersection on the main roads, when vehicles from the site need to cross over oncoming traffic.

Table 27 - Operational Phase - Intersection Safety

Issue	Intersection Safety	
	Description of Impact	
	The increased traffic volumes at intersections will increase the potential risk of accidents at the intersections, resulting in serious injuries or even fatalities, especially at the intersection on the main roads, when vehicles from the site need to cross over oncoming traffic.	
Type of Impact	Indirect	
Nature of Impact	Negative	
Phases	Operation	
Criteria	Without Mitigation	With Mitigation
Intensity	High	High
Duration	Short-term	Short-term
Extent	Site	Site
Consequence	Medium	Medium
Probability	Definite / Continuous	Definite / Continuous

Significance	Medium -	Medium -
Degree to which impact can be reversed	<i>The affected environment will not be able to recover from the impact - permanently modified</i>	
Degree to which impact may cause irreplaceable loss of resources	<i>The resource is irreparably damaged and is not represented elsewhere</i>	
Degree to which impact can be mitigated	<i>Mitigation exists and will notably reduce the significance of impacts</i>	
Mitigation actions		
The following measures are recommended:	<i>Compile TMP, refer to Section 11 of the Traffic Report. Reduce speed at intersections and use appropriate traffic warning signs Identify alternative routes where possible Request the assistance of local law enforcement Ensure that all site vehicles are roadworthy, visible, adequately marked, and operated by an appropriately licenced operator.</i>	
Monitoring		
The following monitoring is recommended:	<i>Incident register and ongoing road safety awareness training</i>	
Cumulative impacts		
Nature of cumulative impacts	<i>The cumulative impact due to the increased traffic volumes at intersections will increase the potential risk of accidents at the intersections, resulting in serious injuries or even fatalities, especially at the intersection on the main roads, when vehicles from the site need to cross over oncoming traffic.</i>	
Rating of cumulative impacts	Without Mitigation	With Mitigation
	Medium -	Medium -

10.2.3 Decommissioning Phase

As part of the decommissioning process, a separate traffic impact assessment should be undertaken since many of the characteristics related to the traffic impact assessment, i.e. access routes, road geometry, traffic volumes, etc., would have changed over the operational life of the development. Thus, the impact assessment for the decommissioning phase has not been provided.

10.2.4 No-go Alternative

If the proposed development does not materialise, the increase in the traffic volume will not transpire, resulting in the following impacts:

Road Degradation

Less traffic on the roads means that the rate of degradation of the roads will be less. However, the maintenance of the roads will not be augmented by the proposed development. Improved maintenance of the roads will improve the quality of life for the road users and could increase the economic opportunities in the area. The status quo is therefore rated as of low negative significance.

Road Safety

Less traffic on the roads means less probability of an incident, reducing the likelihood of a fatality. Therefore the impact is neutral.

Statement

The improved road maintenance counteracts the negative impacts on the road network due to the development and economic prospects the development will bring to the local community and the impact the development has on a national scale.

11 TRAFFIC MANAGEMENT PLAN

As recommended in section 10, a Traffic Management Plan (TMP) for the project needs to be developed by the appointed contractor to execute the construction of the proposed developments. The TMP must consider all the potential risks along the access routes and the roads on the site.

The main objectives of a TMP are to identify potential risks and mitigation measures to be implemented to negate the potential risks as far as reasonably possible. When compiling the TMP, preventing traffic congestion and minimising impacts to existing users on public roads needs to be a key consideration. Although the TMP needs to cover all phases of the development, the focus of the TMP will be the construction phase since this is when the traffic movements and risks are most significant.

The TMP shall therefore be developed by the contractor appointed to construct the proposed development. The implementation of the TMP needs to be vigorously managed.

A description of the most pertinent elements of the construction phase, together with the proposed transportation routes, are summarised below:

- Abnormal loads, including transformers and BESS components, emanating from one of the main commercial centres in South Africa are expected to be on the MR 00295 via NR 001, as the Rooihogte Pass and Burger Pass, will prevent these vehicles from approaching the proposed development from Montagu;*
- Site deliveries emanating from major commercial centres within South Africa are expected to be on MR 00295 via NR 001;*
- Aggregate and cement for the concrete batching plant are envisaged to be transported to the site from commercial sources via MR 00295;*
- Personnel commuting routes originating from the local community will access the proposed developments on the MR 00295, from both the north and south; and*
- The layout of the proposed development needs to address the interaction of site vehicles with vehicles on the public road network.*

Other key points include, inter alia:

- Inclusion of a section of the TMP in the induction training for all personnel travelling to the proposed developments;*
- Outlining of specific traffic management measures across all phases of the proposed developments;*
- Identification of specific routes for each type of vehicle needed to transport equipment and materials to the proposed developments;*
- Identification of mitigation measures to minimise impacts on existing road users;*
- Reduction of the number of private and individual vehicles travelling to the proposed developments;*
- Provision of minibuses/buses for personnel commuting to the proposed developments;*
- Scheduling of deliveries by heavy vehicles to avoid the formation of convoys. Sufficient distance must be maintained between heavy vehicles to allow light vehicles to overtake safely;*
- Avoidance of routes which pass through homesteads and/or dangerous intersections;*
- Alternative routes to and from the proposed development are to be identified and used as far as possible, thus spreading the traffic on the public road network; and*
- Identification of the repair and maintenance strategy to be adopted during the various phases of the development.*

12 CONCLUSION AND RECOMMENDATIONS

Mainstream is proposing to develop a 140 MW Ezelsjacht WEF, a 110 MW Ezelsjacht SEF, BESS, IPP substation and supporting infrastructure.

This report represents the traffic impact assessment for the Ezelsjacht SEF.

12.1 CONCLUSION

Based on the information provided in this document, the following conclusions can be drawn:

Assessment Assumptions

- A project duration of 24 months is expected for the Ezelsjacht SEF. Which relates to an active construction phase of 18 months;
- The simultaneous development of both the Ezelsjacht WEF, Ezelsjacht SEF, and associated infrastructure to present the highest possible peak traffic volumes is a worst-case scenario for the assessment;
- During the peak construction phase, cumulative impact, worst-case scenario, includes simultaneous construction of the Ezelsjacht WEF, Ezelsjacht SEF, and associated infrastructure. Resulting in a combined workforce complement is assumed to be in the order 560;
- Cumulative impact during the operational phase includes the simultaneous operation of both Ezelsjacht WEF and Ezelsjacht SEF;
- The development of other renewable projects in the area are all along the NR 001, and fail to impact the road network used by the Ezelsjacht SEF;
- It is not possible to determine the volume of traffic that will be generated during the decommissioning phase. It can, however, be expected that the volumes will be lower than during the construction phase. As part of the decommissioning process, a separate traffic impact assessment should be undertaken, since many of the characteristics related to the traffic impact assessment, i.e. access routes, road geometry, traffic volumes etc., would have changed over the operational life of the development.

Road Conditions

- The majority of the roads in the study area are paved roads and are in a good condition, access roads to the proposed development are anticipated to be gravel;
- It is proposed that the majority of the deliveries to the proposed developments will be transported via the MR 00295, accessed from the NR 001;
- It is envisaged that the intersection at NR 001 and MR 00295, will need to be upgraded to facilitate the delivery of abnormal loads to the proposed development;
- The expected traffic increase on the road network during the peak construction phase will lead to more significant wear and tear on the roads but will not have an undue detrimental impact on the structure of the roads if the roads are properly maintained. The developer shall contribute to maintaining the public road network affected by the development as identified by the local road authorities. It is proposed that the developer contribute to the maintenance of the road network during the construction and the operational phases, commencing the year after successfully achieving Commercial Operation; and

- *Additional ongoing funding from the wind farms towards the maintenance of the roads will have a positive impact on the local road conditions and community.*

Transportation Route

- *The development is accessed from well-established transportation routes between large commercial centres within South Africa;*
- *Previously established transportation routes from the various container terminal to existing wind farms could be used for the transportation of equipment and material, including abnormal loads;*
- *The final route selection is subject to the limitations specified in the transport permits and the vehicles to be used by the appointed logistics company;*
- *All site entrances are to be from the public road network. The use of the existing intersection will need to be finalised in the design phase. Road alignments that require upgrading to accommodate the transportation requirements of equipment and material are to comply with geometric standards and be approved by the relevant roads authorities;*
- *All equipment and material transported to the proposed developments will use MR 00295 from the NR 001;*
- *No anomalies associated with the proposed transportation routes were observed or identified that will compromise the development. However, this will have to be confirmed by the logistics contractor once the preferred WTG supplier has been selected;*

Traffic Volumes

- *The most significant impact on traffic volumes results from the commuting of personnel, to and from the proposed developments, in the morning and the afternoon;*
- *At no point during the construction or operational phases of the Ezelsjacht SEF does the traffic volume on the various roads exceed 50 trips per hour, which is the threshold for a detailed Traffic Impact Assessment;*
- *The traffic volume generated during the peak construction phase of the Ezelsjacht SEF is in the order:*
 - *Peak Traffic: The maximum number of vehicles on the road network within a given hour is estimated to be in the order of 11 vph;*
 - *Diurnal Traffic: The maximum number of vehicles on the road network within a given hour is estimated to be in the order of 6 vph. Which equates to approximately 48 vehicles, over an eight-hour period.*
- *The traffic volume generated during the operational phase of the Ezelsjacht SEF is in the order:*
 - *Peak Traffic: The maximum number of vehicles on the road network within a given hour is estimated to be in the order of 4 vph;*
 - *Diurnal Traffic: The maximum number of vehicles on the road network within a given hour is estimated to be in the order of 4 vph.*
- *The cumulative traffic volume generated during the peak construction phase of the Ezelsjacht SEF and the Ezelsjacht WEF is in the order:*
 - *Peak Traffic: The maximum number of vehicles on the road network within a given hour is estimated to be in the order of 29 vph;*

- *Diurnal Traffic: The maximum number of vehicles on the road network within a given hour is estimated to be in the order of 15 vph. Which equates to approximately 120 vehicles, over an eight-hour period.*
- *The cumulative traffic volume generated during the operational phase of the Ezelsjacht SEF and the Ezelsjacht WEF is in the order of:*
 - *Peak Traffic: The maximum number of vehicles on the road network within a given hour is estimated to be in the order of 8 vph;*
 - *Diurnal Traffic: The maximum number of vehicles on the road network within a given hour is estimated to be in the order of 8 vph.*

Safety

- *The winding road through the mountain passes on the MR 00295 is a serious safety concern;*
- *This is an agricultural area, home to many species of small fauna, including livestock and wild animals. Stray animals on/crossing the road is a common occurrence that could result in a collision;*
- *Additional vehicles on the road will be subject to these hazards, with a potential for an increase in incidents;*
- *The use of the public road network by the concrete delivery trucks is a concern that needs to be avoided and addressed by the developer, by means of the provision of an interlinking road network and additional batching plants so that using the public roads for the delivery of concrete is negated.*

12.2 RECOMMENDATIONS

Based on the conclusions of this report, the following recommendations are made and should be included in the conditions of the environmental authorisation:

- *All remedial work or modifications to any of the public roads shall be done in consultation with and have the approval of the local road's authority (as is standard practice, this will be finalised during and be a requirement of the municipal planning approval process);*
- *The intersection onto the MR 00295 from the NR 001 is to be upgraded by the developer to accommodate the expected transportation requirements. This upgrade would need to be implemented to facilitate the delivery of abnormal loads to the proposed development;*
- *The developer shall contribute to the maintenance of all roads affected by the development, during the construction and operational phases of the development;*
- *A Traffic Management Plan (TMP) is required to outline specific traffic management measures across all phases of the development. The focus of the TMP will be the construction phase since this is when the traffic movements and risks are most significant. TMP be compiled once the contractor has been appointed and all the relevant details of the construction process are known;*
- *The TMP should consider the scope of the development and take cognisance of the existing condition of the road network at the time the project commences;*
- *The developer shall ensure that the contractor provides the necessary driver training to key personnel to minimise the potential of incidents on the public road network;*
- *The developer shall ensure that the contractor erects temporary signs warning motorists of construction vehicles on the approaches to the access road;*

- *The developer shall ensure that the condition of the roads impacted by the construction of the development is left in a similar or better state once the construction phase is complete;*
- *The interaction of concrete delivery trucks on the public road network is a serious concern that needs to be mitigated prior to the approval of the proposed development;*
- *Implement the relevant transport impact mitigation measures as detailed in Section 10.2 above.*

Considering the above findings, it can be concluded that the proposed development of the Ezelsjacht SEF will have a notable increase in traffic volumes on the road network during the peak construction phase of the proposed developments. However, this report has assessed the impact of these additional traffic volumes on the surrounding road network will be well within the acceptable level of service. The increase in traffic volumes will lead to greater wear and tear, especially during construction, but will not have an undue detrimental impact on the road network within the study area if the mitigation measures are undertaken.

It is the reasoned opinion of the author that the proposed development of the Ezelsjacht SEF can be approved from a traffic and transportation perspective as there are no constraints or notable impacts that would jeopardise the implementation of the development, subject to the specific requirements included within this report.

13 APPENDICES

Appendix 1: Declaration

Appendix 2: NEMA Requirements for Specialist Reports

Appendix 3: Curriculum Vitae

APPENDIX 1 - DECLARATION

I, Athol Carl Schwarz, as the appointed specialist, hereby declare/affirm the correctness of the information provided or to be provided as part of the application, and that I:

- in terms of the general requirement to be independent:
 - other than fair remuneration for work performed/to be performed in terms of this application, have no business, financial, personal or other interest in the activity or application and that there are no circumstances that may compromise my objectivity; or
 - am not independent, but another specialist that meets the general requirements set out in Regulation 13 has been appointed to review my work (Note: a declaration by the review specialist must be submitted);
- in terms of the remainder of the general requirements for a specialist, am fully aware of and meet all of the requirements and that failure to comply with any the requirements may result in disqualification;
- have disclosed/will disclose, to the applicant, the Department and interested and affected parties, all material information that has or may have the potential to influence the decision of the Department or the objectivity of any report, plan or document prepared or to be prepared as part of the application;
- have ensured/will ensure that information containing all relevant facts in respect of the application was/will be distributed or was/will be made available to interested and affected parties and the public and that participation by interested and affected parties was/will be facilitated in such a manner that all interested and affected parties were/will be provided with a reasonable opportunity to participate and to provide comments;
- have ensured/will ensure that the comments of all interested and affected parties were/will be considered, recorded and submitted to the Department in respect of the application;
- have ensured/will ensure the inclusion of inputs and recommendations from the specialist reports in respect of the application, where relevant;
- have kept/will keep a register of all interested and affected parties that participate/d in the public participation process; and
- am aware that a false declaration is an offence in terms of regulation 48 of the 2014 NEMA EIA Regulations.



Signature of the specialist:

Athol Schwarz

Name:

10th October 2022

Date:

APPENDIX 2 - NEMA REQUIREMENTS FOR SPECIALIST REPORTS

Appendix 6	Specialist Report content as required by the NEMA 2014 EIA Regulations, as amended	Section
1 (1)(a)	(i) the specialist who prepared the report; and	Appendix 3
	(ii) the expertise of that specialist to compile a specialist report including a curriculum vitae;	
(b)	a declaration that the specialist is independent in a form as may be specified by the competent authority;	Appendix 1
(c)	an indication of the scope of, and the purpose for which, the report was prepared;	Section 5.2
(cA)	an indication of the quality and age of the base data used for the specialist report;	Section 7.1.2
(cB)	a description of existing impacts on the site, cumulative impacts of the development and levels of acceptable change;	Section 8 & 9
(d)	the duration, date and season of the site investigation and the relevance of the season to the outcome of the assessment;	
(e)	a description of the methodology adopted in preparing the report or carrying out the specialised process, inclusive of equipment and modelling used;	Section 5.4
(f)	details of an assessment of the specifically identified sensitivity of the site related to the proposed activity or activities and its associated structures and infrastructure, inclusive of a site plan identifying site alternatives;	Section 6.1
(g)	an identification of any areas to be avoided, including buffers;	NA
(h)	a map superimposing the activity including the associated structures and infrastructure on the environmental sensitivities of the site including areas to be avoided, including buffers;	NA
(i)	a description of any assumptions made and any uncertainties or gaps in knowledge;	Section 5.5
(j)	a description of the findings and potential implications of such findings on the impact of the proposed activity, or activities;	Section 10
(k)	any mitigation measures for inclusion in the EMPr;	Section 12.2
(l)	any conditions for inclusion in the environmental authorisation;	Section 12.2
(m)	any monitoring requirements for inclusion in the EMPr or environmental authorisation;	NA
(n)	a reasoned opinion-	Section 12.2
	(i) whether the proposed activity or portions thereof should be authorised; and	
	(iA) regarding the acceptability of the proposed activity or activities; and (ii) if the opinion is that the proposed activity or portions thereof should be authorised, any avoidance, management and mitigation measures that should be included in the EMPr, and where applicable, the closure plan;	
(o)	a description of any consultation process that was undertaken during the course of preparing the specialist report;	NA
(p)	a summary and copies of any comments received during any consultation process and where applicable all responses thereto; and	NA
(q)	any other information requested by the competent authority.	NA
2	Where a government notice gazetted by the Minister provides for any protocol or minimum information requirement to be applied to a specialist report, the requirements as indicated in such notice will apply.	N/A

APPENDIX 3 - CURRICULUM VITAE

ATHOL SCHWARZ Pr Tech Eng

Independent Author

Athol, is a Professionally Registered Civil Engineering Technologist with more than 35 years of experience, specialising in Civil and Structural Engineering services for renewable energy facilities and infrastructure. These services range from the concept phase all the way through to project close-out, including inter alia: design, contract and construction management phases.

Since 2010, Athol was employed by Hatch, as a Civil Engineering Author working on numerous infrastructure and renewable energy projects (including wind farms, fixed and rotating PV solar plants, CPV solar plants) for various Independent Power Producers (IPP) / Developers.

Athol has experience in traffic impact assessments, transportation route analysis, infrastructure development and design, construction and project management (NEC), with a keen eye for detail.

SPECIFIC RELEVANT EXPERIENCE

- Red Cap Energy (Pty) Ltd - Impofu Wind Farms consisting of Impofu North Wind Farm, Impofu West Wind Farm and Impofu East Wind Farm
- juwi Renewable Energies (Pty) Ltd – Paulputs Traffic Impact Assessment
- CPV1 Solar - Touwsriver Solar, Western Cape, 36 MW Concentrated Photovoltaic Plant (1500 trackers), supervised civil infrastructure activities
- juwi Renewable Energies (Pty) Ltd - Moorreesberg Wind Energy Facility, Moorreesberg, Western Cape, consisting of 25 wind Turbine Generators - feasibility study for the routing of the access roads.
- juwi Renewable Energies (Pty) Ltd - Garob Wind Farm, Copperton, Northern Cape, consists of 46 Acciona 3.0 MW Wind Turbine Generators - conducted a hydrological study to determine the potential impact of the flood levels on the development,
- juwi Renewable Energies (Pty) Ltd - Wolf Wind Farm, Kleinpoort, Eastern Cape, consisting of 28 Wind Turbine Generators - identify the most viable access point onto the property and internal access road.
- Scatec Solar AS (Norway) - Dreunberg Filter Yard (Capacitor bank), 75 MW Single-axis PV plant – Burgersdorp, Eastern Cape – Quality control of civil activities.
- Scatec Solar AS (Norway) - Linde Filter Yard (Capacitor bank), 36.8 MW Single-axis PV plant – Hanover, Northern Cape – Quality control of civil activities.
- Scatec Solar AS (Norway) - Kalkbult Filter Yard (Capacitor bank), 75 MW Single-axis PV plant – De Aar, Northern Cape – Quality control of civil activities.
- juwi Renewable Energies (Pty) Ltd - Keiskammahoek Wind Farm, King William's Town, Eastern Cape, consisting of 16 Wind Turbine Generators - feasibility study to minimise the impact on the commercial plantation due to the development of Keiskammahoek Wind Farm
- South Africa Mainstream Renewable Power De Aar PV (Pty) Ltd - 50 MW PV Plan – De Aar, Northern Cape – clients engineer
- South Africa Mainstream Renewable Power Droogfontein PV (Pty) Ltd – 50 MW PV Plan – Kimberly, Northern Cape – clients engineer
- juwi Solar ZA Construction 3 (Pty) Ltd - Aries, 9.7 MW PV Plant – Kenhardt, Northern Cape - civil author services and Traffic Impact Assessment
- juwi Solar ZA Construction 3 (Pty) Ltd - Konkoonsies, 9.7 MW PV Plan – Pofadder, Northern Cape - civil author services and Traffic Impact Assessment
- juwi Renewable Energies (Pty) Ltd - Namies Wind Energy Facility, near Aggeneys, Northern Cape, consists of between 46 and 58 wind turbine generators - transportation route assessment



EDUCATION

Master's Diploma in Technology – Civil: Structures (1989)

National Higher Diploma (1987)

National Diploma (1986)

LANGUAGES

- English
- Afrikaans
- French (limited)

PROF AFFILIATIONS

- ECSA - Professional Engineering Technologist,
- SAICE - South African Institution of Civil Engineering - Member

COMPETENCES

- Structural Design (concrete and steel),
- Project and Construction Management

SOFTWARE

- MS Office
- MS Projects
- Micro Station and Autocad
- Prokon
- Model Maker

- *juwi Renewable Energies (Pty) Ltd - Outeniqua Wind Farm (North), Uniondale, Western Cape - transportation route assessment*
- *juwi Renewable Energies (Pty) Ltd - Wolf Wind Farm, Kleinpoort, Eastern Cape consisting of 25 Wind Turbine Generators - feasibility study for the access routes*
- *juwi Renewable Energies (Pty) Ltd - Outeniqua Wind Farm (South), Uniondale, Western Cape, 16 Wind Turbine Generators - feasibility study for the access routes*
- *UMOYA ENERGY (Pty) Ltd - Hopefield Wind Farm, approximately 6 km south-east of the town of Hopefield, Western Cape, consisting of 37, Vestas 1.8 MW WTG – ACS HV Yard and Substation.*
- *South Africa Mainstream Renewable Power Jeffreys Bay (Pty) Ltd - Jeffreys Bay Wind Farm, Humansdorp, Eastern Cape, consists of 60 Siemens 2.3 MW WTG - review the foundation design for the wind towers - review the designs for compliance to the national standards.*
- *juwi Solar ZA Construction 3 (Pty) Ltd - RustMo1, 6.8 MW PV Plant – Rustenburg, North-West - author services regarding access and internal gravel roads*
- *Barrick Africa (Pty) Ltd - Buzwagi Gold Mine in Tanzania – a feasibility study.*
- *juwi Renewable Energies (Pty) Ltd - Garob Wind Farm, Copperton, Northern Cape, consists of 46 Acciona 3.0 MW Wind Turbine Generators - transportation management plan.*
- *Slim Sun Swartland Solar Park - SlimSun Solar - 5 MW PV Plant – Malmesbury, Western Cape – ACS for HV Yard and Substation.*
- *Cennergi (Pty) Ltd - Kopleegte Switching Station at Amakhala Emoyen Phase 1, Bedford, Eastern Cape, consisting of 56 Nordex, 2,4 MW Wind Turbines Generators- ACS for HV Yard and Substation.*
- *EXXARO Resources Ltd And Watt Energy (Pty) Ltd - Wittekleibosch Switching Station at Tsitsikamma Community Wind Farm, Tsitsikamma, Eastern Cape, consists of 31 Vestas 3.0 MW WTG - ACS for HV Yard and Substation.*
- *Windlab Developments South Africa (Pty) Ltd - AMAKALA EMOYENI – Phase 2, Bedford, Eastern Cape, consisting of 66 WTG - feasibility study for access and internal road network*
- *Windlab Developments South Africa (Pty) Ltd – Phase 1, Bedford, Eastern Cape, consisting of 56 Nordex, 2,4 MW Wind Turbines Generators - feasibility study for access and internal road network*
- *IBEDRROLA - Klip Heuvel Switching Station at Caledon Wind Farm, Caledon, Western Cape, consisting of 9, Sinovel 3.0 MW Wind Turbines Generators – ACS for HV Yard and Substation.*
- *EXXARO Resources Ltd - Lephalale 60 MW PV Plant, 13 km north-west of the town of Lephalale, Limpopo - ACS for HV Yard and Substation.*
- *SASOL Technology - 3.6 MW PV Demonstration Plant – civil author services*
- *Solafrica Pty (Ltd) - Bokpoort CSP Project, a 50 MW Concentrating Solar Thermal Power Station (CSP – parabolic trough) located approximately 80 km east-south-east of Upington, Northern Cape - prepared enquiry documentation for the geotechnical investigation and topographic survey*