

REV	DATE	REVISIONS	DRAWN	CHECK	APPR	REFERENCE DRAWINGS
01	SEPT 2017	ORIGINAL				

**GIBB**  
ENGINEERING & ARCHITECTURE

Podium at Menlyn  
43 Ingersol Drive  
Menlyn, 0181  
Tel: +27 12 348 5880

PO Box 35007  
Menlo Park  
0102  
web: www.gibb.co.za

NAME	DATE	CONSULTANT APPROVAL	DATE
DRAWN BY: J. ARRIE	NOV 2017	ENGINEERING MANAGER	
CHECKED BY: M. JOUBERT	01 DEC 2017	LEAD ENGINEER	
PROFESSIONAL ENGINEER		MECHANICAL / PIPING	
NAME: M. JOUBERT		STRUCTURAL / ARCH	
Reg. No: 750793		CIVIL	
DATE: 01/12/2017		ELECTRICAL	
		C & I	
SIGNATURE: _____		PROCESS	

**exxaro**  
POWERING POSSIBILITY

THIS DRAWING IS THE PROPERTY OF EXXARO Pty LTD AND MAY NOT BE COPIED OR REPRODUCED EITHER WHOLLY OR IN PART WITHOUT WRITTEN PERMISSION

EXXARO ACCEPTED			
SIGNATURE	DATE	SIGNATURE	DATE

CENTRE: **MATLA**

**MATLA\_MINE**  
**SUBLIME\_ACCESS\_ROAD**  
**SUBLIME\_ACCESS\_ROAD**  
**XXX\_XXX**  
**XXX\_XXX**  
**LAYOUT PLAN - ENVIROMENTAL**

DRAWING NUMBER: **MAT-GIB-CL-0003**

SCALE: 1:1000

SHEET	REV	
01	00	<b>A0</b>

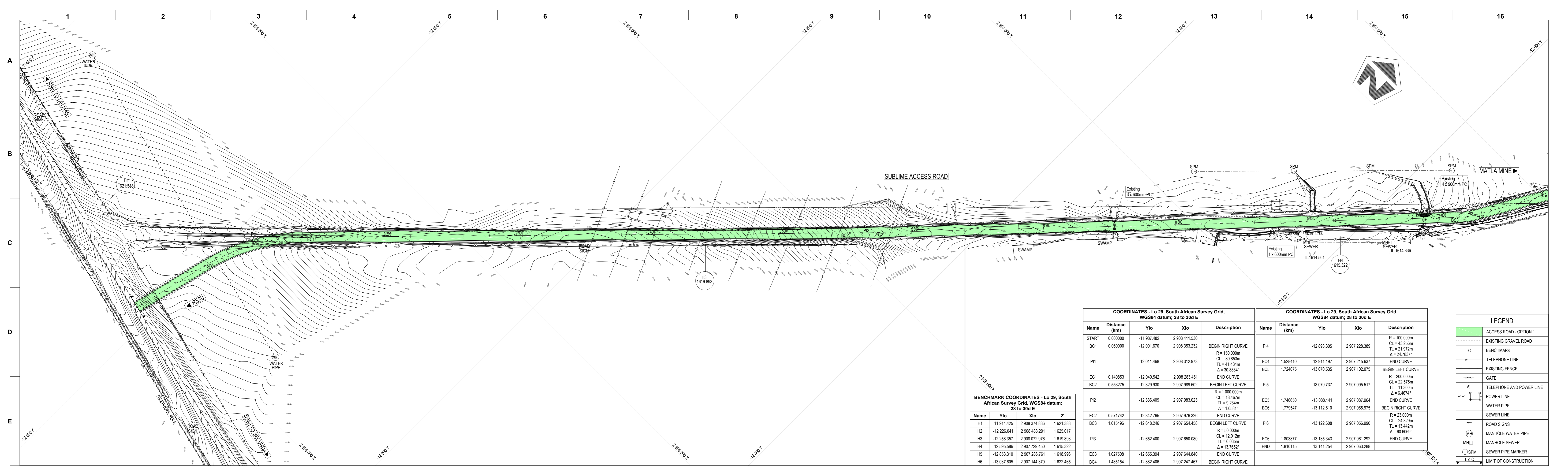

**BENCHMARK COORDINATES - Lo 29, South African Survey Grid, WGS84 datum; 28 to 30d E**

Name	Y10	X10	Z
H1	-11 914.425	2 908 374.836	1 621.388
H2	-12 226.041	2 908 488.291	1 625.017
H3	-12 258.357	2 908 072.976	1 619.893
H4	-12 995.595	2 907 729.450	1 615.322
H5	-12 853.310	2 907 286.761	1 618.996
H6	-13 037.695	2 907 144.370	1 622.465

**COORDINATES - Lo 29, South African Survey Grid, WGS84 datum; 28 to 30d E**

Name	Distance (km)	Y10	X10	Description
START	0.000000	-11 987.482	2 908 411.530	
BC1	0.060000	-12 001.670	2 908 353.232	BEGIN RIGHT CURVE
PI1		-12 011.468	2 908 312.973	R = 150.000m CL = 80.853m TL = 41.434m Δ = 30.854°
EC1	0.140853	-12 040.542	2 908 283.451	END CURVE
BC2	0.533275	-12 329.930	2 907 989.602	BEGIN LEFT CURVE
PI2		-12 336.409	2 907 983.023	R = 1 000.000m CL = 19.467m TL = 9.234m Δ = 1.0581°
EC2	0.571742	-12 342.765	2 907 976.326	END CURVE
BC3	1.015496	-12 648.246	2 907 654.458	BEGIN LEFT CURVE
PI3		-12 652.400	2 907 650.080	R = 90.000m CL = 12.010m TL = 6.035m Δ = 13.7652°
EC3	1.027508	-12 655.394	2 907 644.840	END CURVE
BC4	1.485154	-12 882.406	2 907 247.467	BEGIN RIGHT CURVE

**COORDINATES - Lo 29, South African Survey Grid, WGS84 datum; 28 to 30d E**

Name	Distance (km)	Y10	X10	Description
PI4		-12 893.305	2 907 228.389	R = 100.000m CL = 43.255m TL = 21.972m Δ = 24.7837°
EC4	1.528410	-12 911.197	2 907 216.637	END CURVE
BC5	1.724075	-13 070.535	2 907 102.075	BEGIN LEFT CURVE
PI5		-13 079.737	2 907 095.517	R = 200.000m CL = 22.575m TL = 11.260m Δ = 6.4651°
EC5	1.746650	-13 088.141	2 907 087.964	END CURVE
BC6	1.779547	-13 112.610	2 907 065.975	BEGIN RIGHT CURVE
PI6		-13 122.608	2 907 056.990	R = 23.000m CL = 24.329m TL = 13.440m Δ = 60.6969°
EC6	1.803877	-13 135.343	2 907 061.292	END CURVE
END	1.810115	-13 141.254	2 907 063.288	

**LEGEND**

- ACCESS ROAD - OPTION 1
- EXISTING GRAVEL ROAD
- BENCHMARK
- TELEPHONE LINE
- EXISTING FENCE
- GATE
- TELEPHONE AND POWER LINE
- POWER LINE
- WATER PIPE
- SEWER LINE
- ROAD SIGNS
- MANHOLE WATER PIPE
- MANHOLE SEWER
- SEWER PIPE MARKER
- LIMIT OF CONSTRUCTION

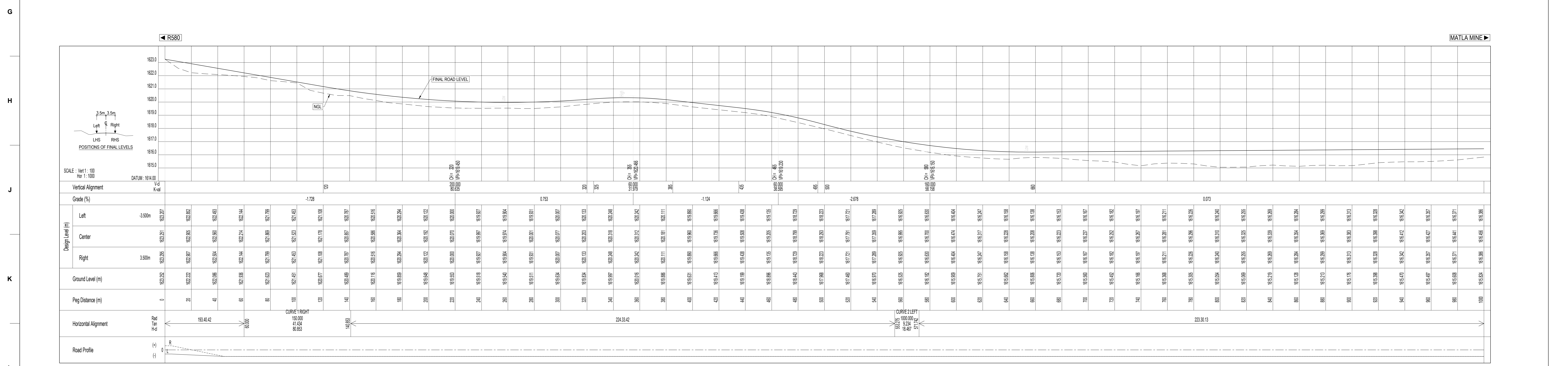
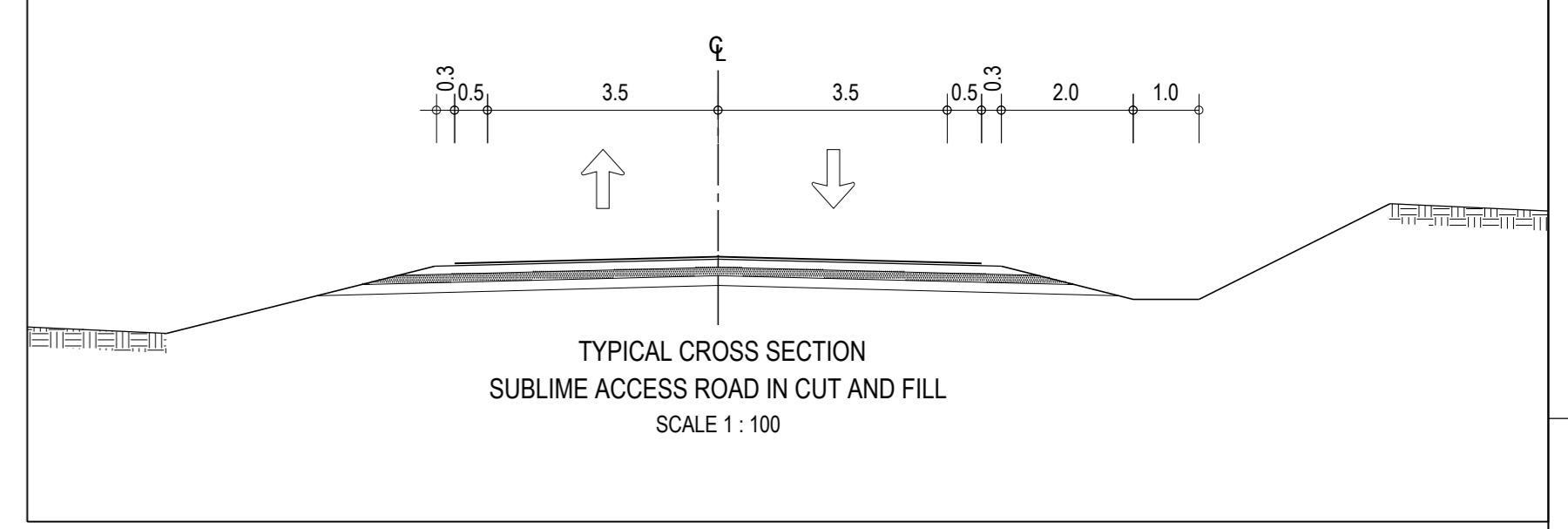

REV	DATE	REVISIONS	DRAWN	CHECK	APPR	REFERENCE DRAWINGS
00	SEPT 2017	ORIGINAL				DRAWING No. DRAWING DESCRIPTION

Podium at Menlyn  
43 Ingersol Drive  
Menlyn, 0181  
Tel: +27 12 348 5880

PO Box 35007  
Menlo Park  
0102  
web: www.gibb.co.za

DRAWN BY	NAME	DATE	CONSULTANT APPROVAL	DATE
CHECKED BY	PROFESSIONAL ENGINEER		ENGINEERING MANAGER	
NAME			LEAD ENGINEER	
REG. No:			MECHANICAL / PIPING	
DATE			STRUCTURAL / ARCH	
SIGNATURE			CIVIL	
			ELECTRICAL	
			C & I	
			PROCESS	

POWERING POSSIBILITY

EXXARO ACCEPTED

SIGNATURE	DATE	SIGNATURE	DATE
MECHANICAL		OWNERS REPRESENTATIVE	
ELECTRICAL		AREA / PROJECT MANAGER	
CIVIL		ENGINEERING MANAGER	
STRUCTURAL		PROCESS & PIPING	
ARCHITECTURAL		INSTRUMENTATION	

CENTRE **GROOTEGLUK**

**TITLE\_LINE\_1**  
**TITLE\_LINE\_2**  
**TITLE\_LINE\_3**  
**TITLE\_LINE\_4**

**LAYOUT PLAN AND LONGITUDINAL SECTION**  
**KM 0 TO KM 1.000**

DRAWING NUMBER  
**ECG-XXX-XXX-XX-XX-XXXX**

DRAWING NUMBER  
J37158/LP/01

SCALE  
AS SHOWN

SHEET REV  
01 00 **A0**

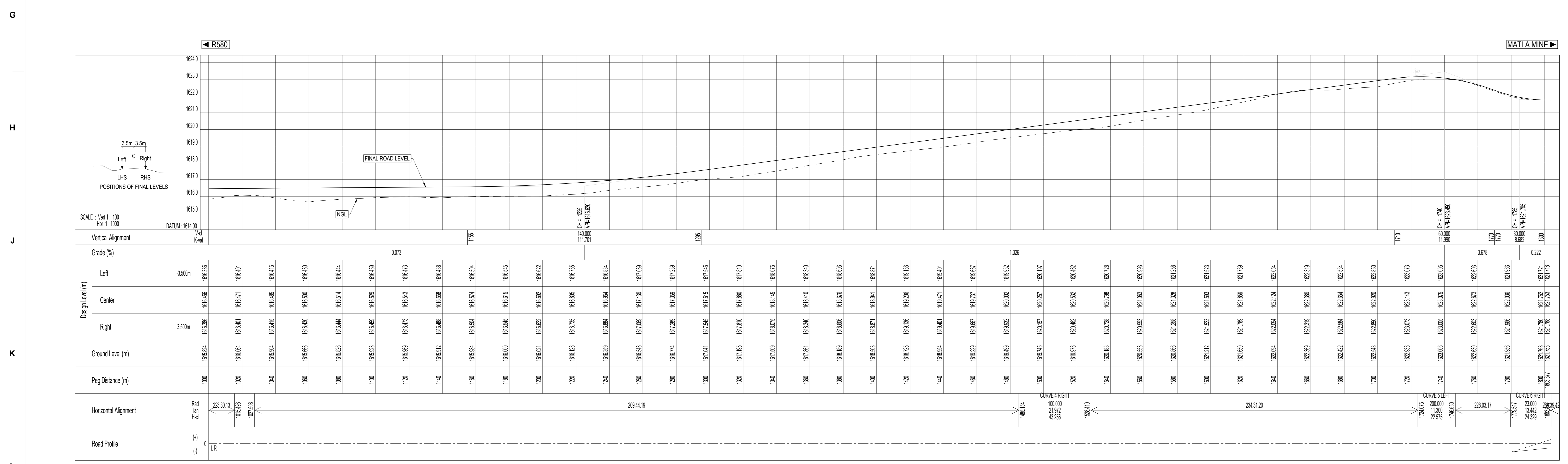
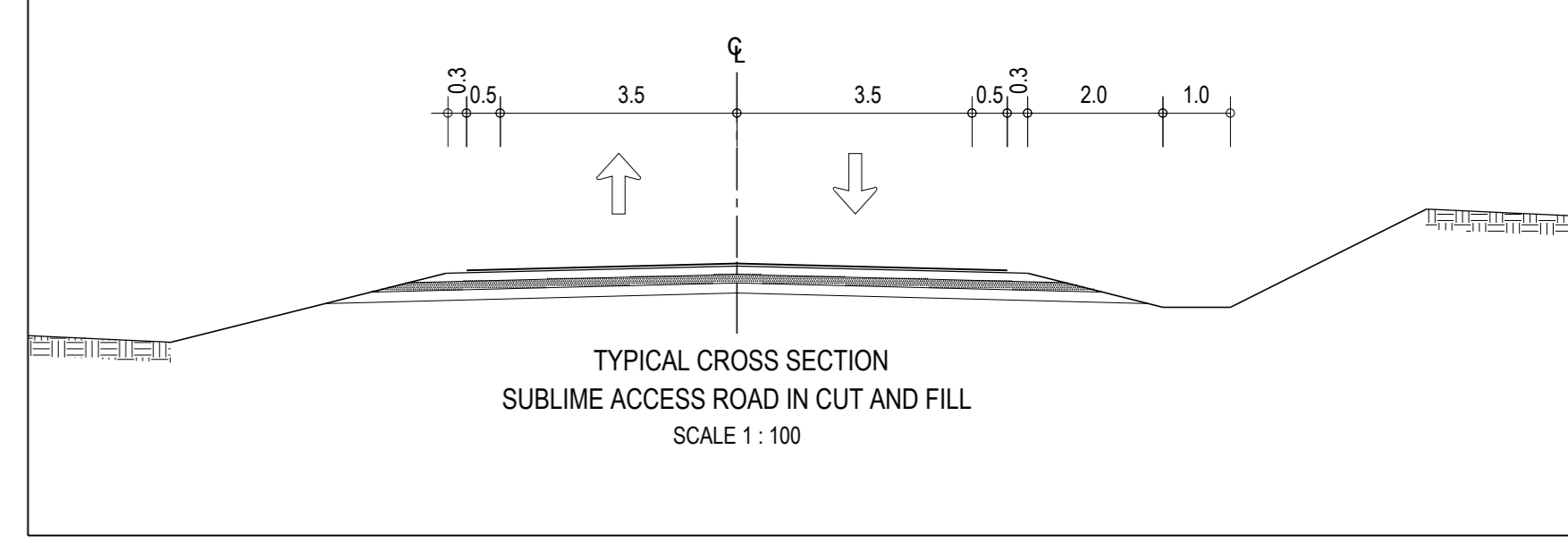
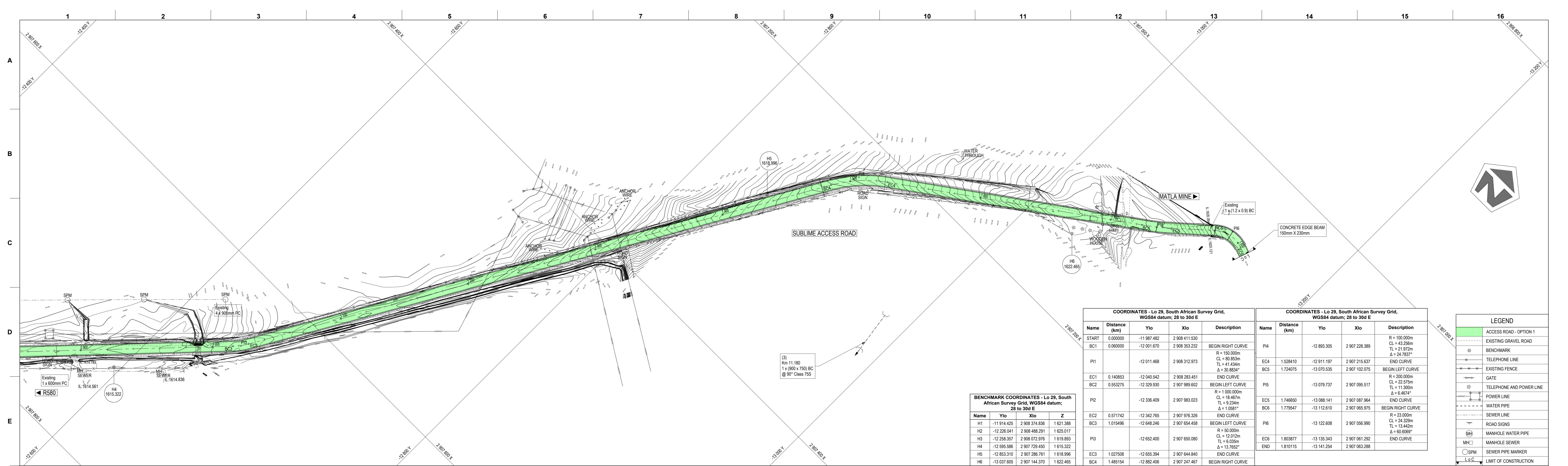

REV	DATE	REVISIONS	DRAWN	CHECK	APPR	REFERENCE DRAWINGS
00	SEPT 2017	ORIGINAL				DRAWING No. DRAWING DESCRIPTION

**GIBB**  
ENGINEERING & ARCHITECTURE

Podium at Menlyn  
43 Ingersol Drive  
Menlyn, 0181  
Tel: +27 12 348 5880

PO Box 35007  
Menlo Park  
0102  
web: www.gibb.co.za

NAME	DATE	CONSULTANT APPROVAL	DATE
DRAWN BY		ENGINEERING MANAGER	
CHECKED BY		LEAD ENGINEER	
PROFESSIONAL ENGINEER		MECHANICAL / PIPING	
NAME		STRUCTURAL / ARCH	
Reg. No:		CIVIL	
DATE		ELECTRICAL	
SIGNATURE		C & I	
		PROCESS	



EXXARO ACCEPTED			
SIGNATURE	DATE	SIGNATURE	DATE
MECHANICAL		OWNERS REPRESENTATIVE	
ELECTRICAL		AREA / PROJECT MANAGER	
CIVIL		ENGINEERING MANAGER	
STRUCTURAL		PROCESS & PIPING	
ARCHITECTURAL		INSTRUMENTATION	
PROJECT PHASE			
PROJECT NUMBER			

CENTRE **GROOTEGLUK**

**TITLE\_LINE\_1**  
**TITLE\_LINE\_2**  
**TITLE\_LINE\_3**  
**TITLE\_LINE\_4**  
**LAYOUT PLAN AND LONGITUDINAL SECTION**  
**KM 1.000 TO KM 1.800**

DRAWING NUMBER  
**ECG-XXX-XXX-XX-XX-XXXX**

SCALE  
AS-SHOWN

SHEET REV  
01 00 **A0**