

**APPENDIX I:
ENGINEERING DRAWINGS**

FILE NAME: D:\PROJECTS\MD3665\MD3665-RHD-FS-PL-M2-CX-1001\MD3665-RHD-FS-PL-M2-CX-1001.DWG

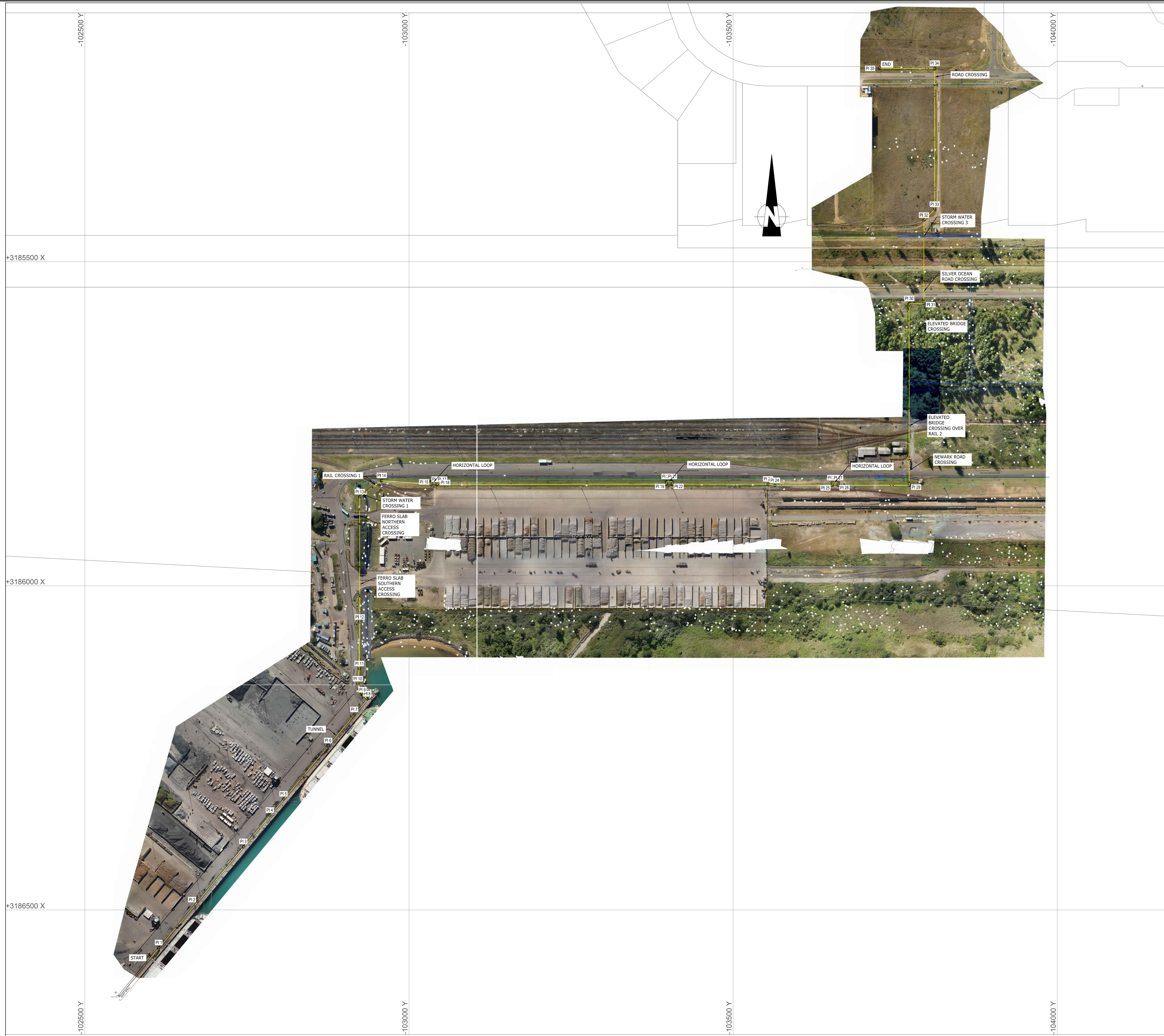

NOTES

COPYRIGHT RESERVED
THE DUPLICATION OF THIS DRAWING IS STRICTLY PROHIBITED

DRAWING No.	REFERENCE DRAWINGS
FS-PL-CX-1002	SMALL SCALE PLAN AND LONGITUDINAL SECTION
FS-PL-CX-1003	PLAN AND LONGITUDINAL SECTION SHEET 1 OF 3
FS-PL-CX-1004	PLAN AND LONGITUDINAL SECTION SHEET 2 OF 3
FS-PL-CX-1005	PLAN AND LONGITUDINAL SECTION SHEET 3 OF 3



PROJECT

**WILMAR
EDIBLE OIL
PIPELINE**

DRAWING DESCRIPTION

LAYOUT PLAN

FOR INFORMATION ONLY

DESIGNED P.G. FISCHER	SIGNATURE AND DATE
DRAWN B. MANS	SIGNATURE AND DATE
DRAWING CHECKED P.G. FISCHER	SIGNATURE AND DATE
DESIGN CHECKED P.G. FISCHER	SIGNATURE AND DATE
PROJ. PRINCIPAL / APPROVED P.G. FISCHER	SIGNATURE AND DATE

No.	DATE	REVISION DESCRIPTION	BY	TO
A	25/10/2018	FOR INFORMATION	B.M.	P.G.F.
B	31/01/2019	FOR INFORMATION	B.M.	P.G.F.
C	16/02/2019	APPROVAL FOR PIPE ROUTE ALIGNMENT	B.M.	P.G.F.
D	17/04/2019	APPROVAL FOR PIPE ROUTE ALIGNMENT NEWARK RD	B.M.	P.G.F.

PROJECT No. MD3665	CONTRACT No.	DATE 18/04/2019
SHEET No. SHEET 1 OF 1	DISCIPLINE CIVIL	SCALE AS SHOWN
DRAWING No. MD3665-RHD-FS-PL-M2-CX-1001	PAPER SIZE A0	REV. D

MD3665-RHD-FS-PL-M2-CX-1000 (LONGITUDINAL SECTION SHEET 1 OF 3)



PLAN
SCALE: 1 : 1000

COORDINATES WGS 84			
PI	Y	X	CHAINAGE
PI15	-103034.26	3185843.46	964.31
PI16	-103034.26	3185839.46	966.31
PI17	-103043.26	3185839.46	977.31
PI18	-103043.26	3185843.86	981.71
PI19	-103397.08	3185843.33	1335.53
PI20	-103397.08	3185839.33	1339.53
PI21	-103406.08	3185839.32	1348.53
PI22	-103406.08	3185843.32	1352.53
PI23	-103553.91	3185843.14	1500.36
PI24	-103564.41	3185845.20	1511.06
PI25	-103653.01	3185845.19	1599.66
PI26	-103653.03	3185841.24	1603.62
PI27	-103662.03	3185841.19	1612.62
PI28	-103662.03	3185845.20	1616.62

NOTE:
THE COORDINATES OF THE PI POINTS REFER TO PIPE No. 1 AS SHOWN ON THE DETAIL DRAWINGS FOR THE APPLICABLE SUPPORT STRUCTURES. ALL SETTING OUT COORDINATES FOR ALL SUPPORT STRUCTURES TO BE CALCULATED FROM THE PI COORDINATES FOR PIPE No.1

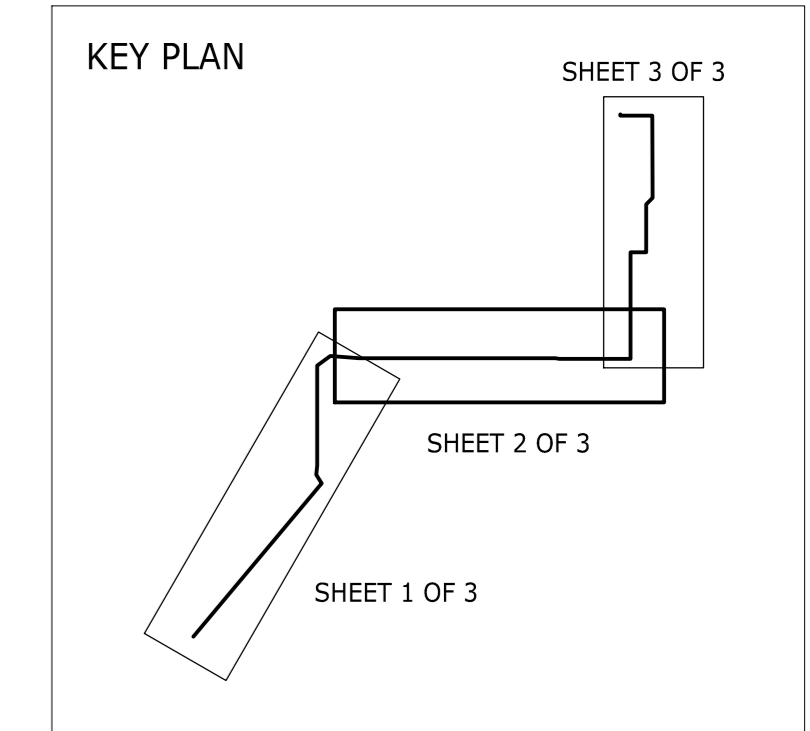

COPYRIGHT RESERVED
THE DUPLICATION OF THIS DRAWING IS STRICTLY PROHIBITED

DRAWING No.	REFERENCE DRAWINGS
FS-PL-CX-1001	LAYOUT
FS-PL-CX-1002	SMALL SCALE PLAN AND LONGITUDINAL SECTION
FS-PL-CX-1003	PLAN AND LONGITUDINAL SECTION SHEET 1 OF 3
FS-PL-CX-1005	PLAN AND LONGITUDINAL SECTION SHEET 3 OF 3



The Boulevard
Umhlanga
19 Park Lane
Umhlanga Rocks
4319

PO Box 1243
Umhlanga Rocks
4300

Tel No. +27 (0) 87 350 6660

PROJECT
WILMAR
EDIBLE OIL
PIPELINE

DRAWING DESCRIPTION
PLAN AND LONGITUDINAL SECTION

FOR INFORMATION ONLY

DESIGNED P.G. FISCHER	SIGNATURE AND DATE
DRAWN B. MANS	SIGNATURE AND DATE
DRAWING CHECKED P.G. FISCHER	SIGNATURE AND DATE
DESIGN CHECKED P.G. FISCHER	SIGNATURE AND DATE
PROJ. PRINCIPAL / APPROVED P.G. FISCHER	SIGNATURE AND DATE

No.	DATE	REVISION DESCRIPTION	BY	TO
A	25/10/2018	FOR INFORMATION	B.M.	P.G.F.
B	21/02/2019	FOR INFORMATION	B.M.	P.G.F.
C	28/02/2019	APPROVAL FOR PIPE ROUTE ALIGNMENT	B.M.	P.G.F.
D	17/04/2019	APPROVAL FOR PIPE ROUTE ALIGNMENT NETWORK RD.	B.M.	P.G.F.

PROJECT No. MD3665	CONTRACT No. 18/04/2019	DATE
SHEET No. 1	DISCIPLINE CIVIL	SCALE AS SHOWN
SHEET 1 OF 1	SCALE AS SHOWN	PAPER SIZE A0
DRAWING No. MD3665-RHD-FS-PL-M2-CX-1004	REV.	

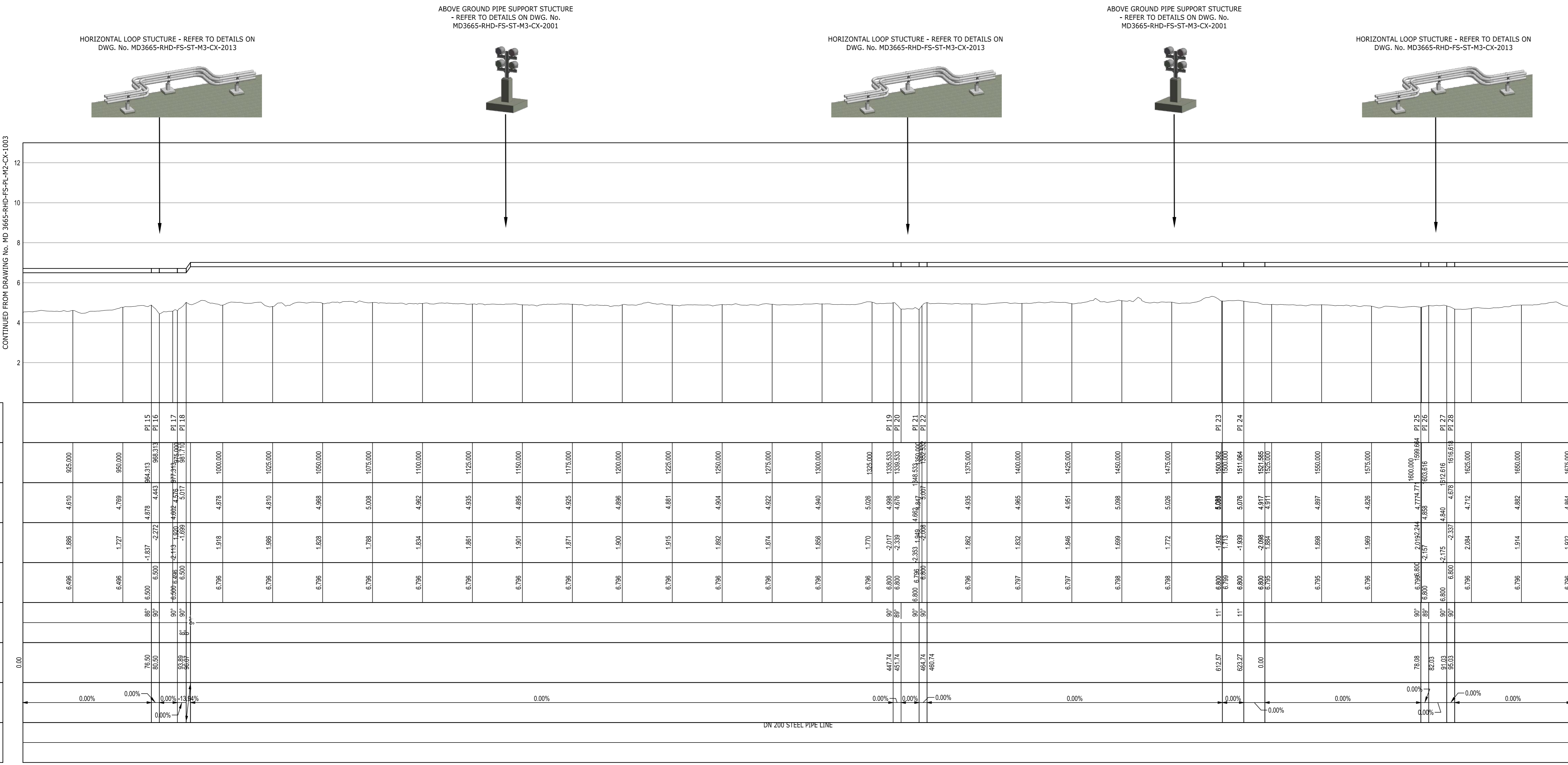

SCALES:
Horizontal 1:1000
Vertical 1:100

DATUM 0.000

REFERENCE	PI 14
CHAINAGE (m)	867.817
GROUND LEVEL	4.684
DEPTH TO INVERT (m)	-2.111
INVERT LEVEL (m)	6.500
CHANGE IN DIRECTION	VERT. INCR. COUMBERED
SLOPE DISTANCE (m)	0.00
PIPE GRADES	0.00%
PIPE DETAILS	

LONGSECTION ALIGNMENT 1
FROM 900.000 TO 1675.000

DN 200 STEEL PIPE LINE

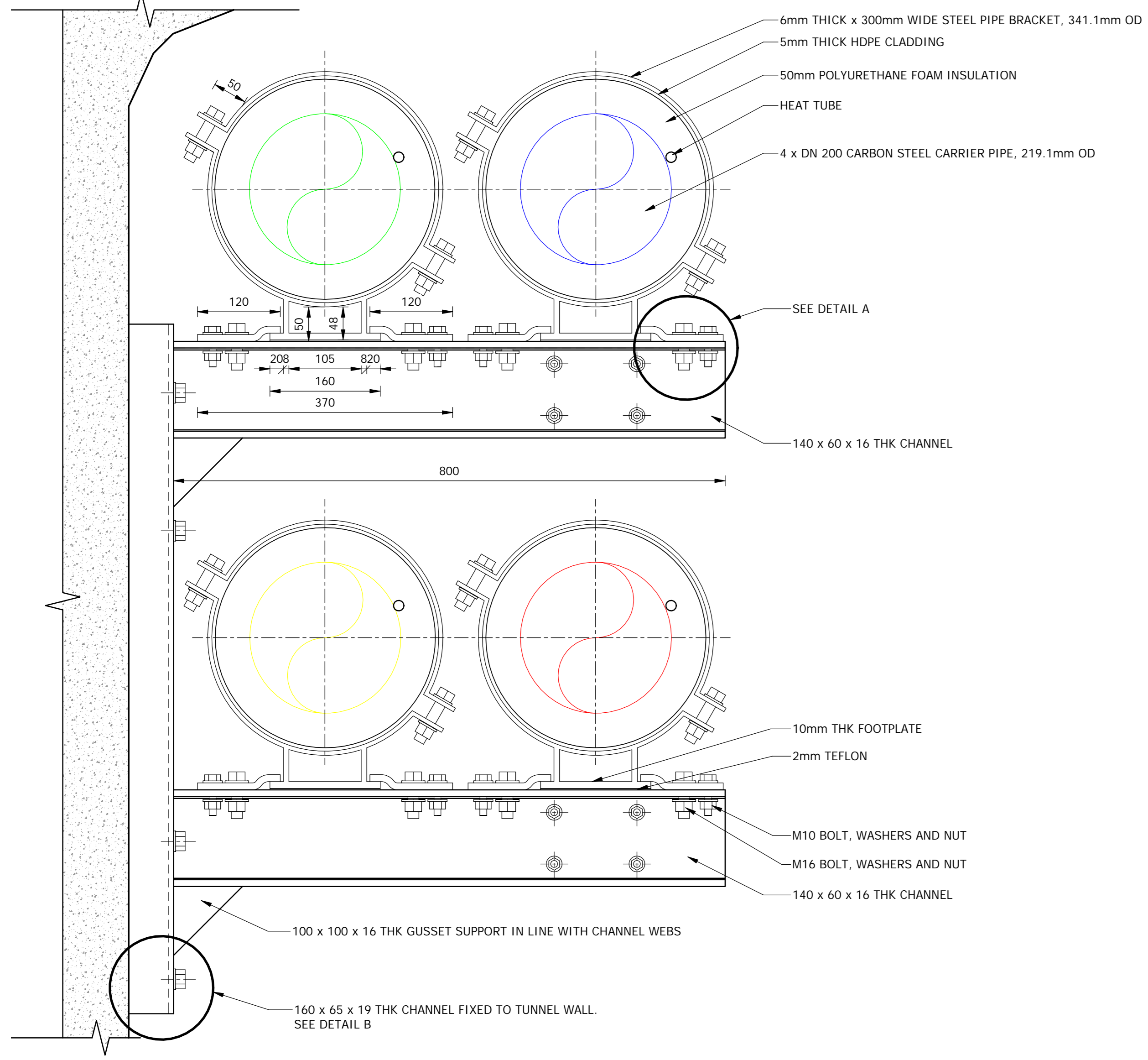

FRONT VIEW
1:5

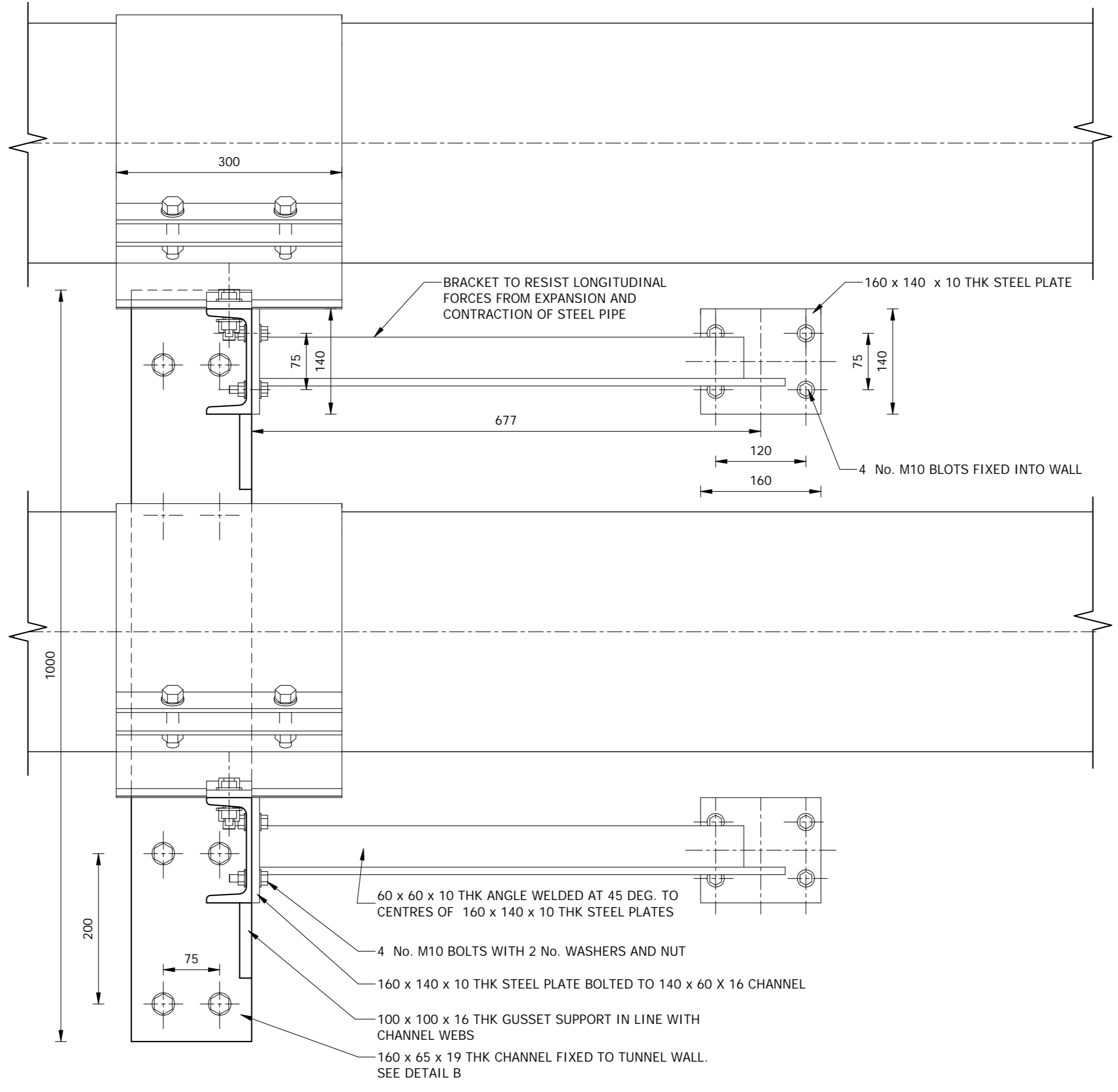

SIDE VIEW
1:5

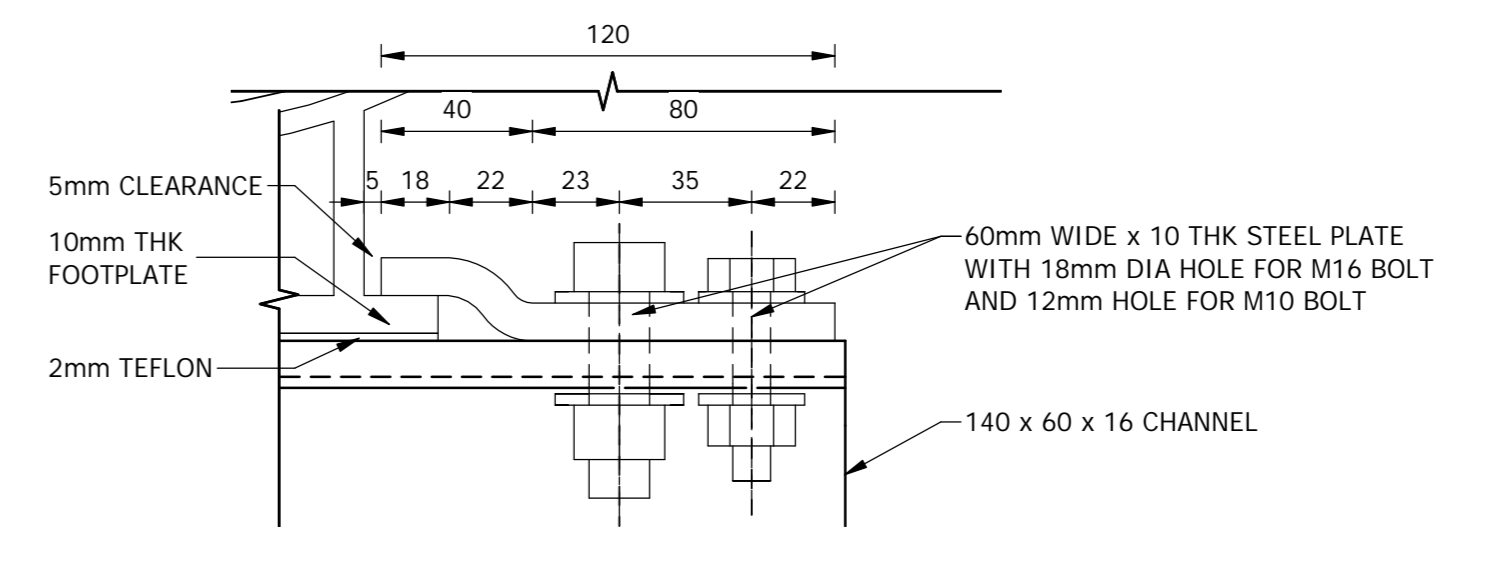

DETAIL A
1:2

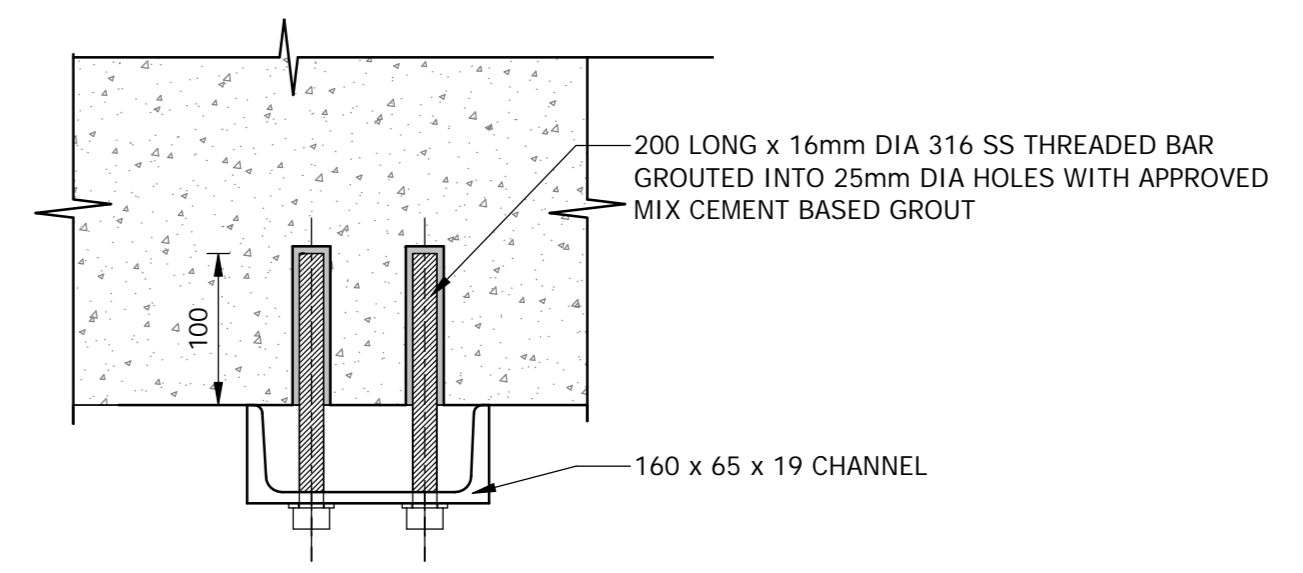

DETAIL B
1:5

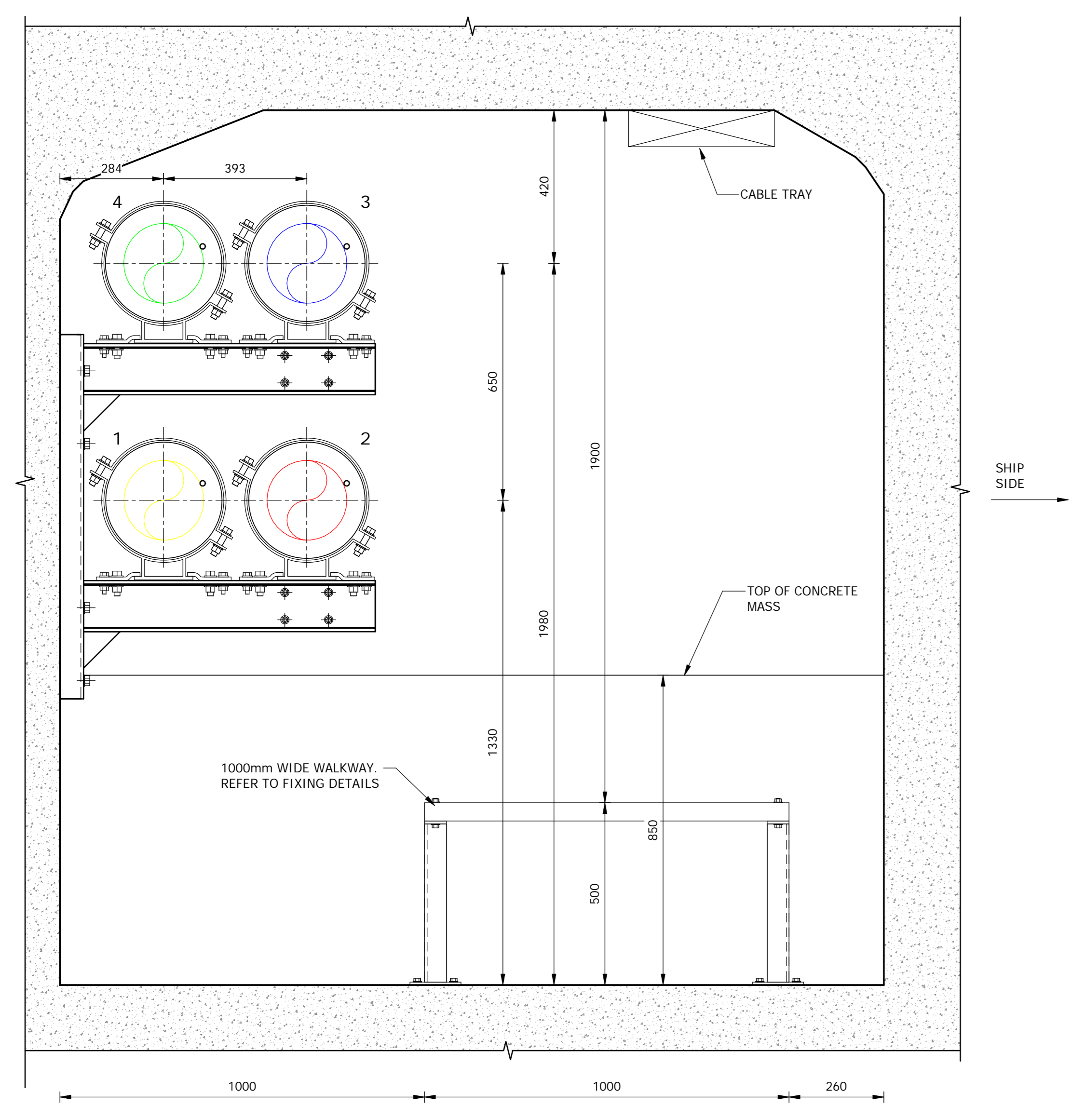

TYPICAL SECTION THROUGH TUNNEL
1:10

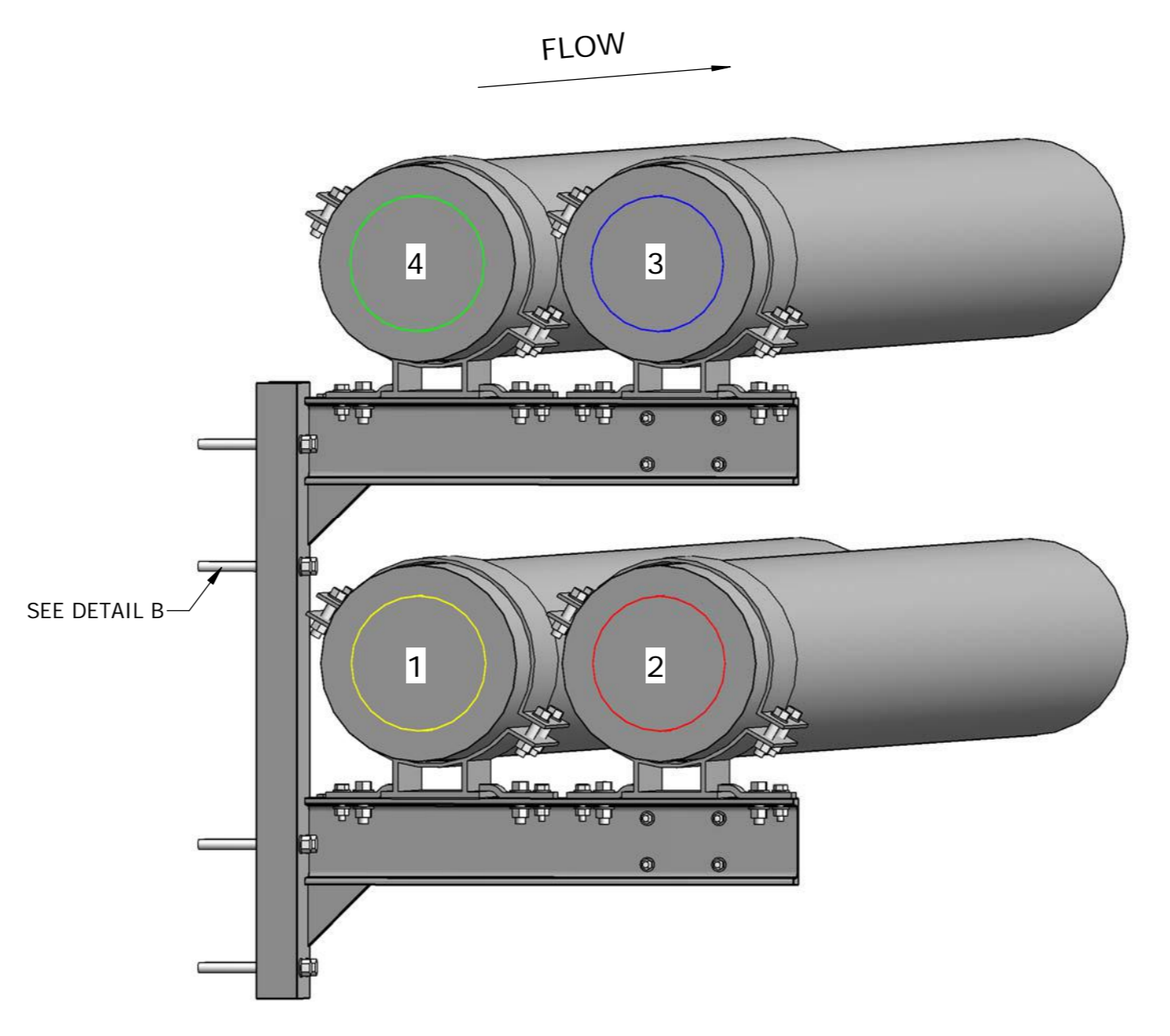

3D VIEW A

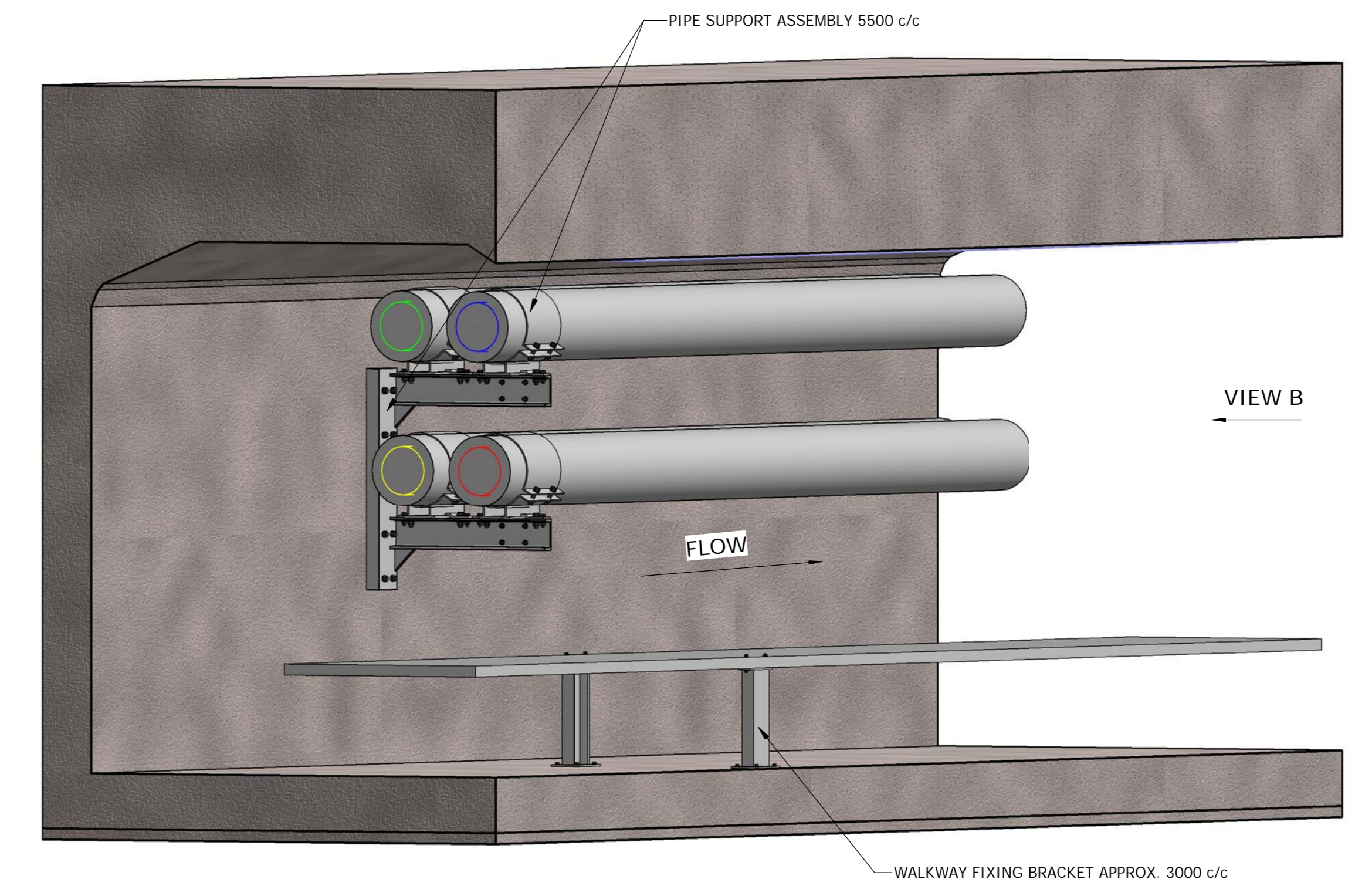

3D VIEW B

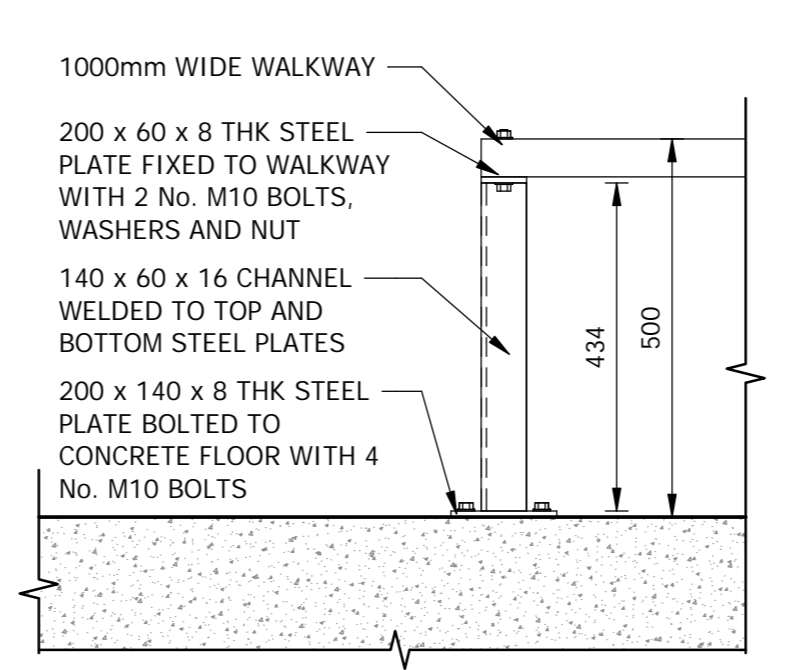

WALKWAY FIXING DETAILS (SEE DETAIL C)
1:10

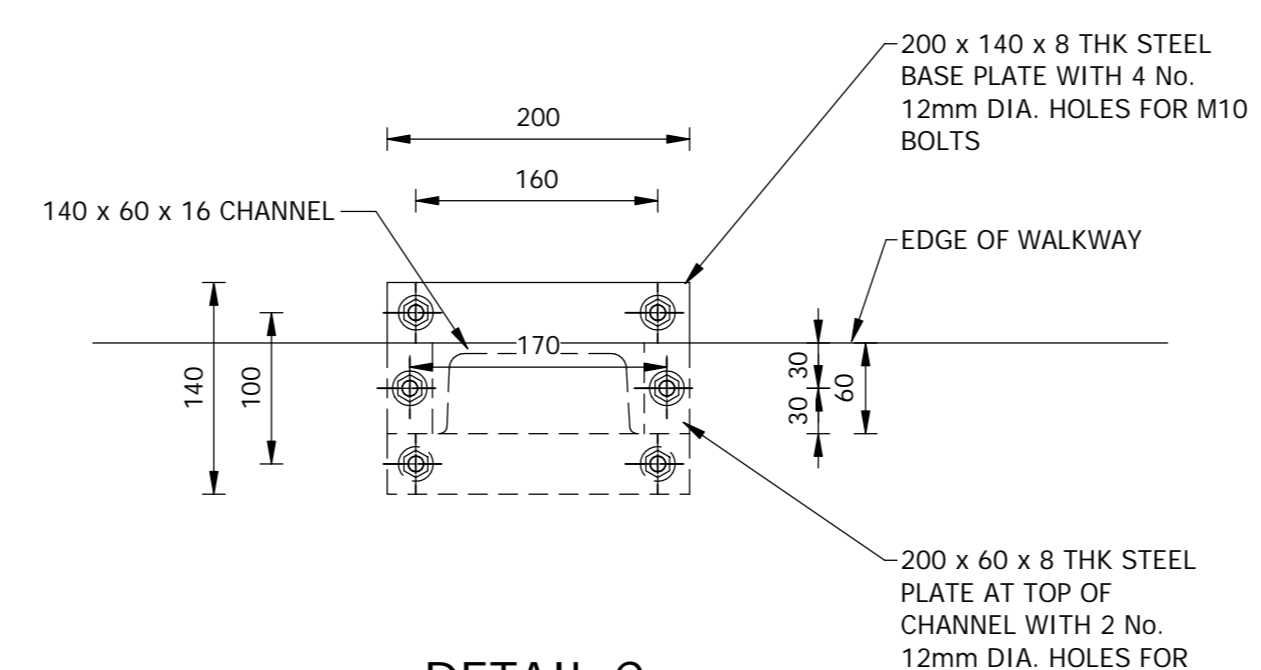

DETAIL C
1:5

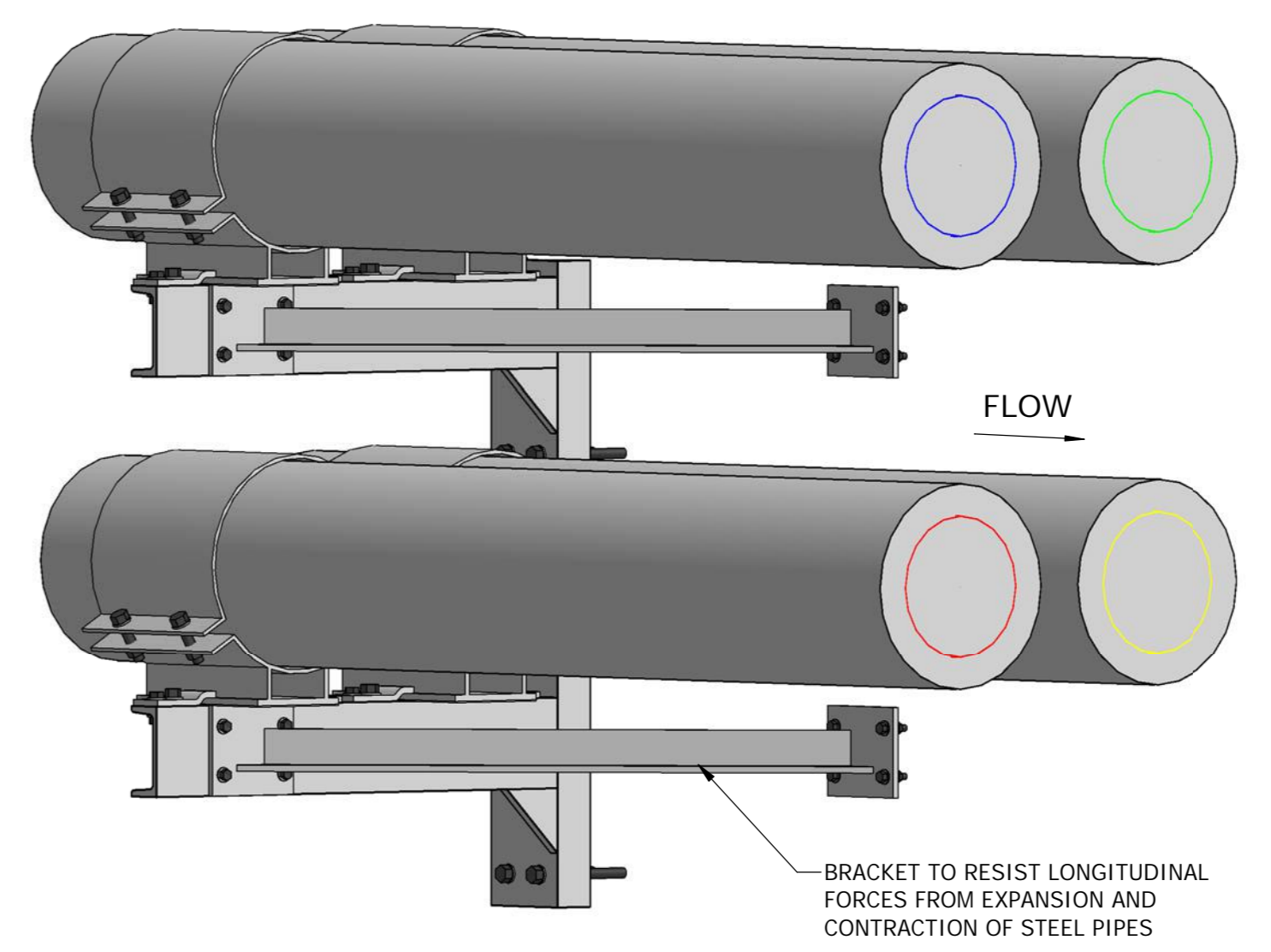

3D VIEW C

NOTES

COPYRIGHT RESERVED
THE DUPLICATION OF THIS DRAWING IS STRICTLY PROHIBITED



PROJECT
WILMAR EDIBLE OIL PIPELINE

DRAWING DESCRIPTION
TYPICAL TUNNEL PIPE SUPPORT STRUCTURE DETAILS

FOR INFORMATION ONLY

DESIGNED: P.G. FISCHER	SIGNATURE AND DATE
DRAWN: B. MANS	SIGNATURE AND DATE
DRAWING CHECKED: P.G. FISCHER	SIGNATURE AND DATE
DESIGN CHECKED: P.G. FISCHER	SIGNATURE AND DATE
PRD. PRINCIPAL / APPROVED: PG. FISCHER	SIGNATURE AND DATE

No.	DATE	REVISION DESCRIPTION	BY	TO
A	23/11/2018	FOR INFORMATION	B.M.	P.G.F.
B	04/02/2019	APPROVAL FOR PIPE ROUTE ALIGNMENT	B.M.	P.G.F.

PROJECT No. MD3665	CONTRACT No.	DATE 2019/03/14 07:59:05 AM
SHEET No. SHEET 1 OF 1	DISCIPLINE CIVIL	SCALE As indicated
		PAPER SIZE A0

DRAWING No. MD3665-RHD-FS-ST-M3-CX-2002	REV. B
---	------------------

C:\Users\m\Documents\163665-RHD-FS-ST-M3-CX-2002\163665-RHD-FS-ST-M3-CX-2002.dwg
 E:\E:\SAVED\LOCATIONS
 163665-RHD-FS-ST-M3-CX-2002

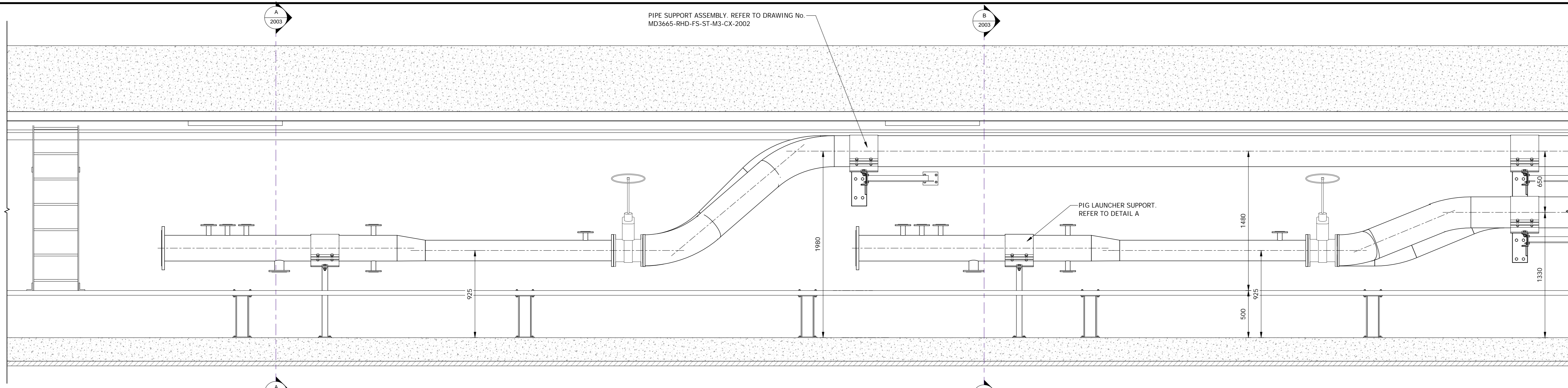

TYPICAL ELEVATION OF PIG LAUNCHER
1 : 20

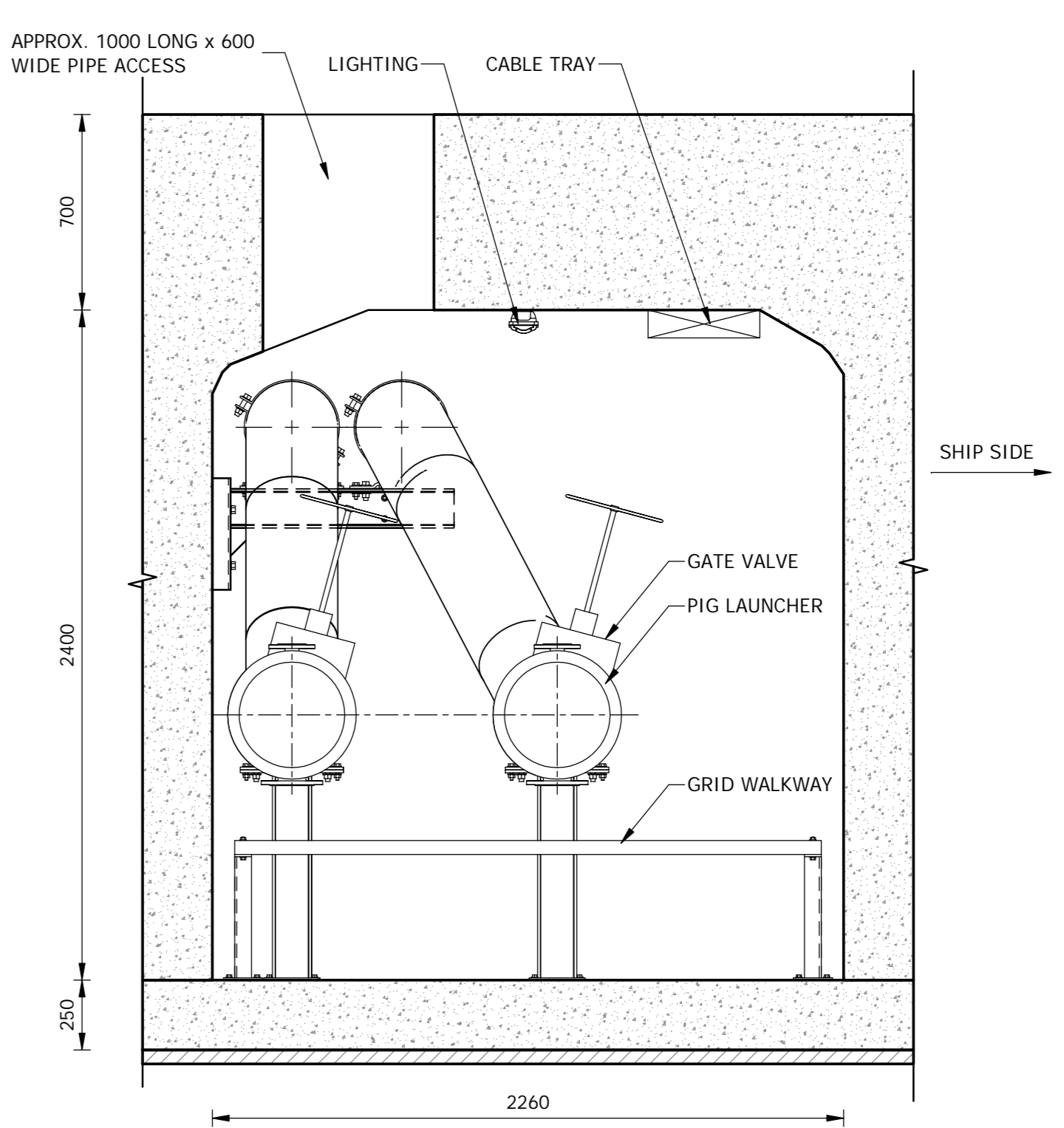

SECTION A - A
1 : 20

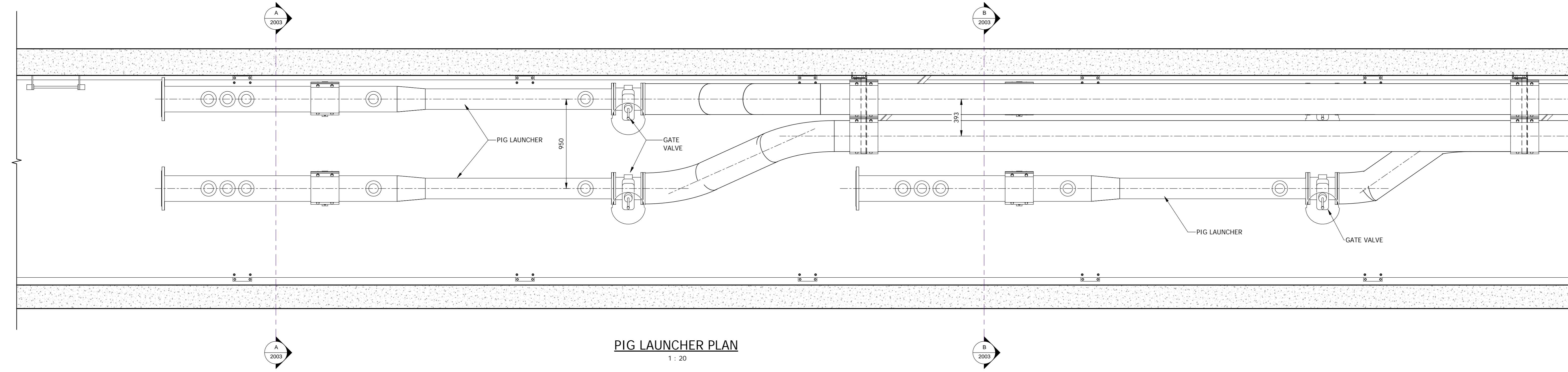

PIG LAUNCHER PLAN
1 : 20

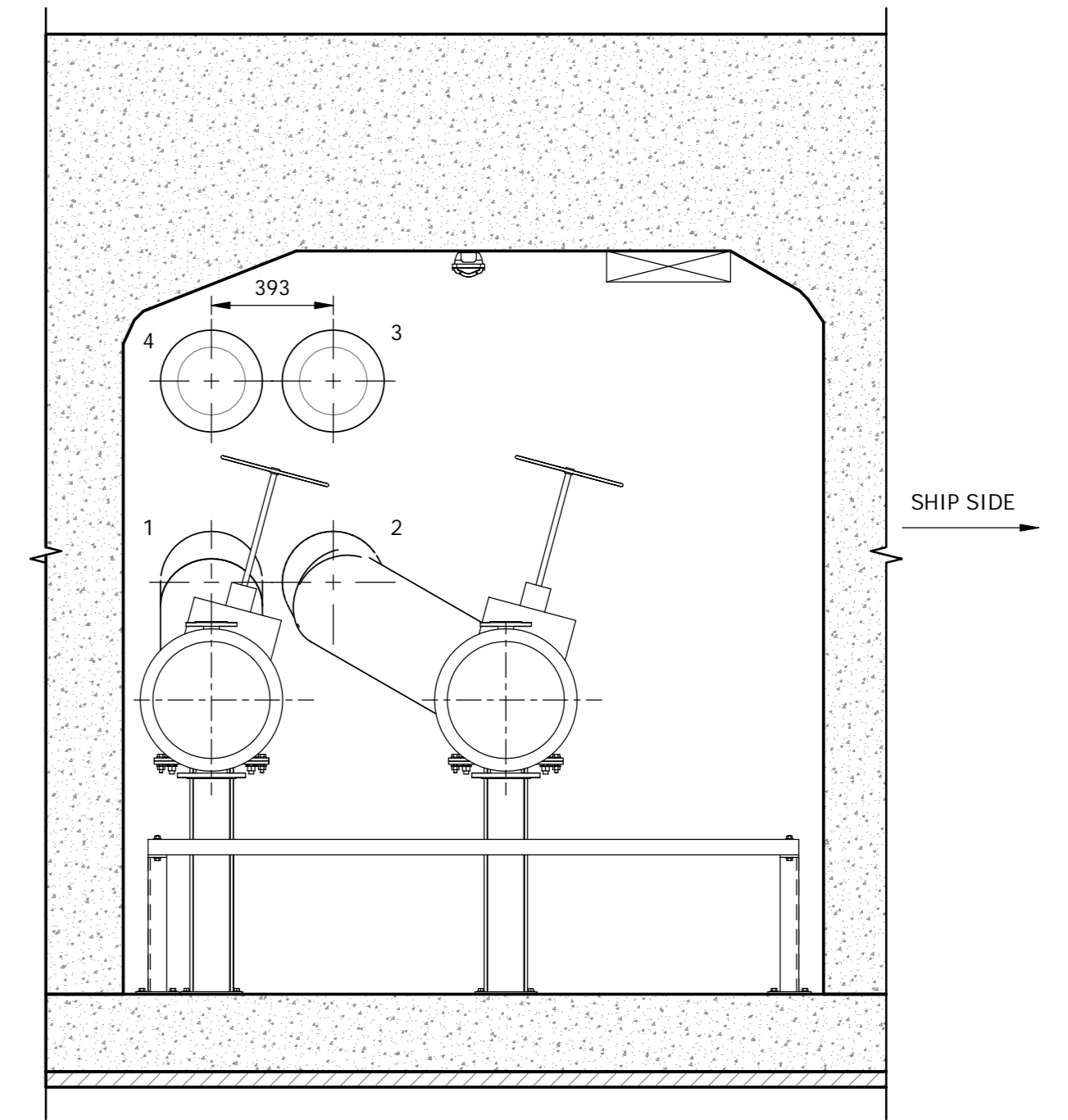

SECTION B - B
1 : 20

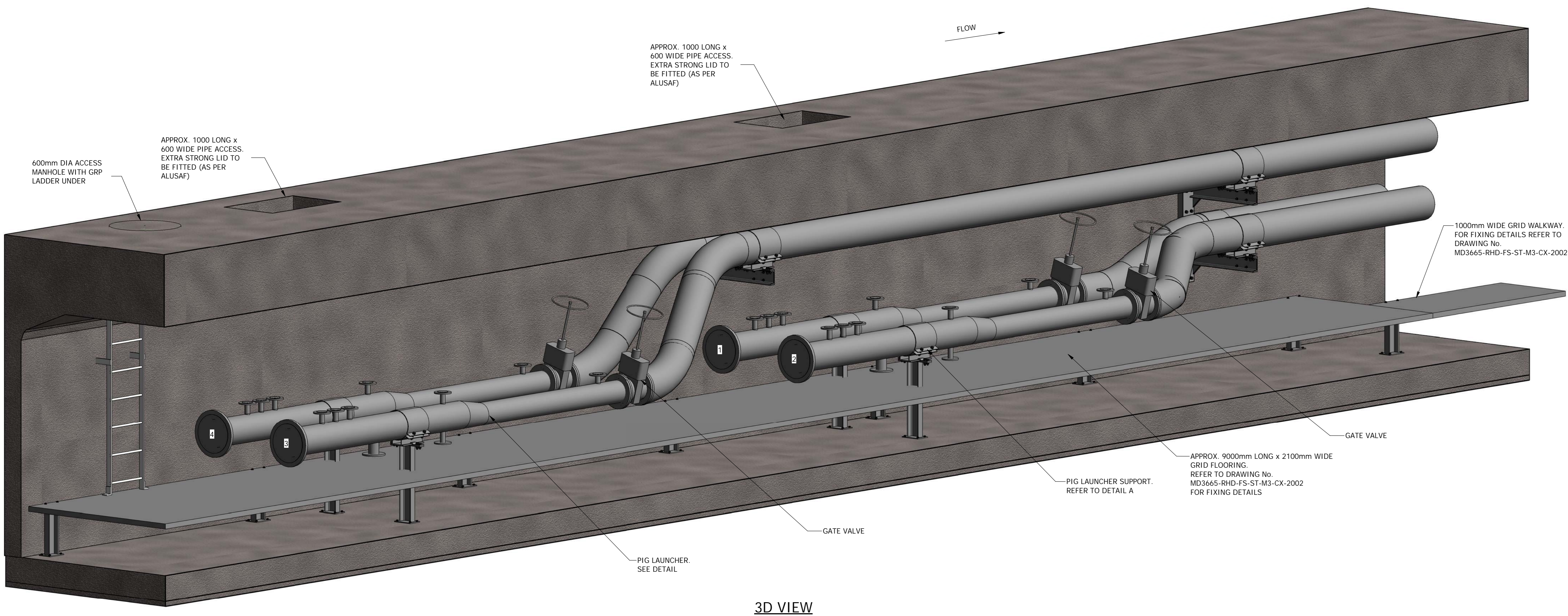

3D VIEW

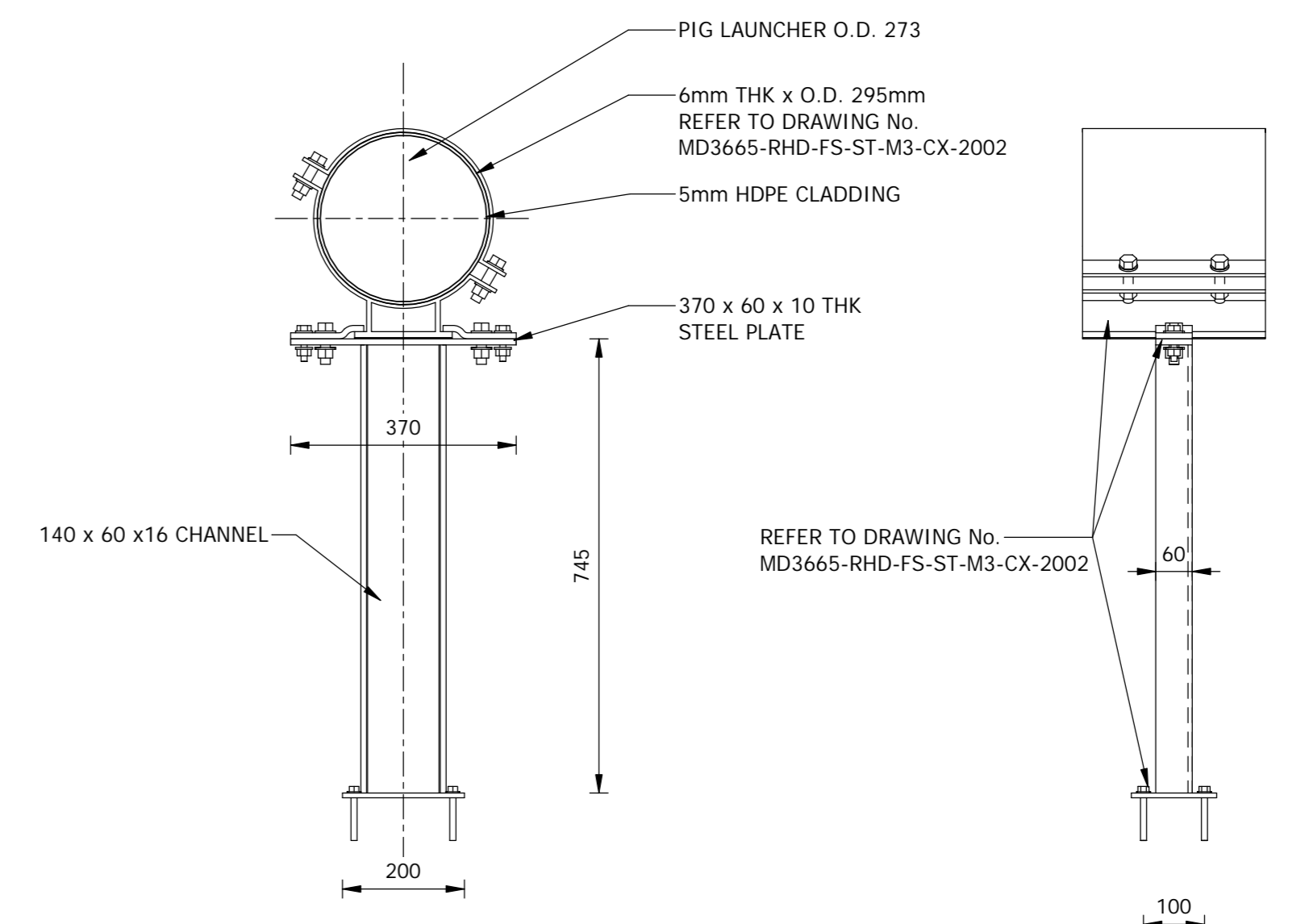

FRONT VIEW
1 : 10

SIDE VIEW
1 : 10

DETAIL A

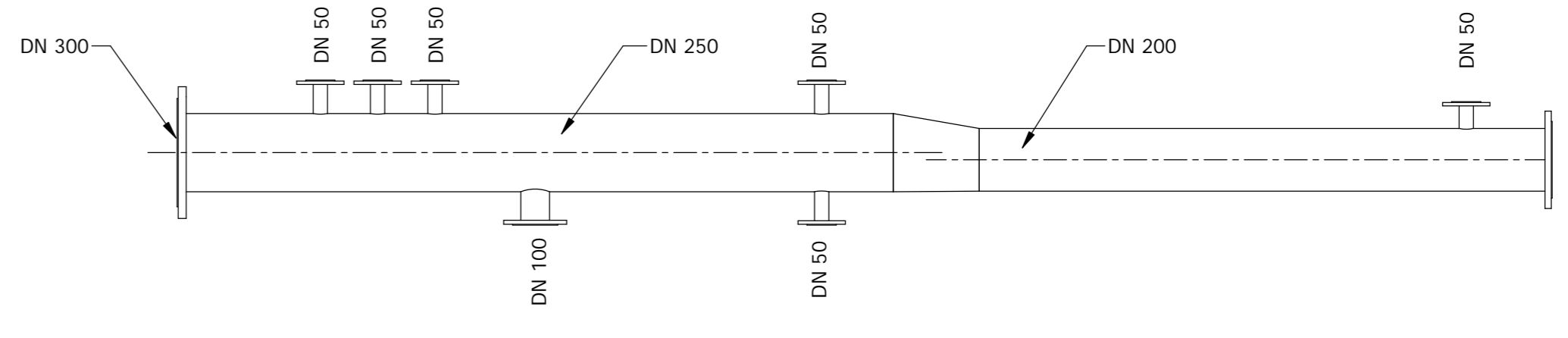

TYPICAL ELEVATION OF PIG BARREL
1 : 20

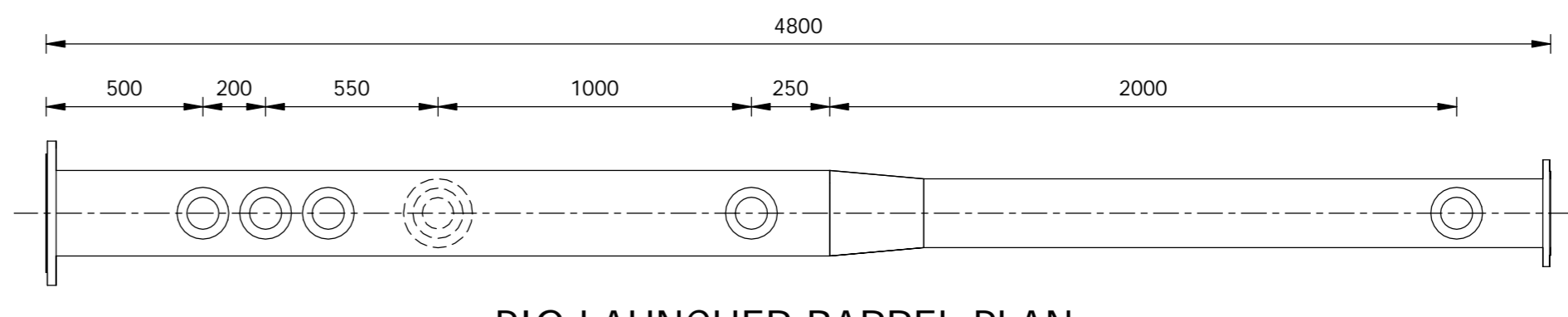

PIG LAUNCHER BARREL PLAN
1 : 20

NOTES

COPYRIGHT RESERVED
THE DUPLICATION OF THIS DRAWING IS STRICTLY PROHIBITED



Royal HaskoningDHV
Enhancing Society Together

The Boulevard
Umhlanga,
19 Park Lane
Umhlanga Rocks
4219

PO Box 1243
Umhlanga Rocks
4220

Tel No. +27 (0) 87 350 6660

PROJECT
WILMAR EDIBLE OIL PIPELINE

DRAWING DESCRIPTION
TYPICAL PIG LAUNCHER DETAILS

FOR INFORMATION ONLY

DESIGNED: P.G. FISCHER	SIGNATURE AND DATE
DRAWN: B. MANS	SIGNATURE AND DATE
DRAWING CHECKED: P.G. FISCHER	SIGNATURE AND DATE
DESIGN CHECKED: P.G. FISCHER	SIGNATURE AND DATE
PROJ. PRINCIPAL / APPROVED: PG. FISCHER	SIGNATURE AND DATE

No.	DATE	REVISION DESCRIPTION	BY	TO
A	16/08/2018	FOR INFORMATION	B.M.	P.G.F.
B	20/02/2019	APPROVAL FOR PIPE ALIGNMENT	B.M.	P.G.F.

PROJECT No. MD3665	CONTRACT No.	DATE 2018/02/14 08:00:55 AM
SHEET No. SHEET 1 OF 1	DISCIPLINE CIVIL	SCALE As indicated
		PAPER SIZE A0

DRAWING No. MD3665-RHD-FS-ST-M3-CX-2003	REV. B
---	------------------

