

EXECUTIVE SUMMARY

In recent decades, the use of wind turbines, concentrated solar plants and photovoltaic plants have been on the increase as it serves as an abundant source of energy. This document specifies setbacks for wind turbines and the reasons for these setbacks from infrastructure as well as setbacks for concentrated solar plants and photovoltaic plants. Setbacks for wind turbines employed in other countries were compared and a general setback to be used by Eskom was suggested for use with wind turbines and other renewable energy generation plants.

CONTROLLED DISCLOSURE

When downloaded from the EDMS, this document is uncontrolled and the responsibility rests with the user to ensure it is in line with the authorised version on the system.

1. INTRODUCTION

During the last few decades, a large amount of wind turbines have been installed in wind farms to accommodate for the large demand of energy and depleting fossil fuels. Wind is one of the most abundant sources of renewable energy. Wind turbines harness the energy of this renewable resource for integration in electricity networks. The extraction of wind energy is its primary function and thus the aerodynamics of the wind turbine is important. There are many different types of wind turbines which will all exhibit different wind flow characteristics. The most common wind turbine used commercially is the Horizontal Axis Wind Turbine. Wind flow characteristics of this turbine are important to analyse as it may have an effect on surrounding infrastructure.

Wind turbines also cause large turbulence downwind that may affect existing infrastructure. Debris or parts of the turbine blade, in the case of a failure, may be tossed behind the turbine and may lead to damage of infrastructure in the wake path.

This document outlines the minimum distances that need to be introduced between a wind turbine and Eskom infrastructure to ensure that debris and / or turbulence would not negatively impact on the infrastructure.

Safety distances of wind turbines from other structures as implemented by other countries were also considered and the reasons for their selection were noted.

Concentrated solar plants and photovoltaic plants setbacks away from substations were also to be considered to prevent restricting possible power line access routes to the substation.

2. SUPPORTING CLAUSES

2.1 SCOPE

This document provides guidance on the safe distance that a wind turbine should be located from any Eskom power line or substation. The document specifies setback distances for transmission lines (220 kV to 765 kV), distribution lines (6.6 kV to 132 kV) and all Eskom substations. Setbacks for concentrated solar plants and photovoltaic plants are also specified away from substations.

2.1.1 Purpose

Setbacks for wind turbines and power lines / substations are required for various reasons. These include possible catastrophic failure of the turbine blade that may release fragments and which may be thrown onto nearby power lines that may result in damage with associated unplanned outages. Turbulence behind the turbine may affect helicopter flight during routine Eskom live line maintenance and

CONTROLLED DISCLOSURE

When downloaded from the EDMS, this document is uncontrolled and the responsibility rests with the user to ensure it is in line with the authorised version on the system.

inspections that may lead to safety risk of the aircraft / personnel. Concentrated solar plants and photovoltaic plants setback away from substations were required to prevent substations from being boxed in by these renewable generation plants limiting line route access to the substations.

2.1.2 Applicability

This document is applicable to the siting of all new and existing wind turbines, concentrated solar plants and photovoltaic plants near power lines and substations.

2.2 NORMATIVE/INFORMATIVE REFERENCES

2.2.1 Normative

1. <http://www.envir.ee/orb.aw/class=file/action=preview/id=1170403/Hiiumaa+turbulence+impact+EMD.pdf>.
2. <http://www.energy.ca.gov/2005publications/CEC-500-2005-184/CEC-500-2005-184.PDF>
3. <http://www.adamscountywind.com/Revised%20Site/Windmills/Adams%20County%20Ordinance/Adams%20County%20Wind%20Ord.htm>
4. http://www.dsireusa.org/incentives/incentive.cfm?Incentive_Code=PA11R&RE=1&EE=1
5. <http://www.wind-watch.org/documents/european-setbacks-minimum-distance-between-wind-turbines-and-habitations/>
6. <http://www.publications.parliament.uk/pa/ld201011/ldbills/017/11017.1-i.html>
7. http://www.caw.ca/assets/pdf/Turbine_Safety_Report.pdf
8. Rogers J, Slegers N, Costello M. (2011) A method for defining wind turbine setback standards. Wind energy 10.1002/we.468

2.2.2 Informative

None

2.3 DEFINITIONS

Definition	Description
Setback	The minimum distance between a wind turbine and boundary line/dwelling/road/infrastructure/servitude etc.
Flicker	Effect caused when rotating wind turbine blades periodically cast shadows
Tip Height	The total height of the wind turbine ie. Hub height plus half rotor diameter (see Figure1)

CONTROLLED DISCLOSURE

When downloaded from the EDMS, this document is uncontrolled and the responsibility rests with the user to ensure it is in line with the authorised version on the system.

2.3.1 Disclosure Classification

Controlled disclosure: controlled disclosure to external parties (either enforced by law, or discretionary).

2.4 ABBREVIATIONS

Abbreviation	Description
None	

2.5 ROLES AND RESPONSIBILITIES

All personnel involved in the positioning wind turbines, concentrated solar plants and photovoltaic plants near power lines/substations must follow the setbacks outlined in this guideline.

2.6 PROCESS FOR MONITORING

Approval by Eskom in writing.

2.7 RELATED/SUPPORTING DOCUMENTS

None

3. DOCUMENT CONTENT

3.1 INTERNATIONAL SETBACK COMPARISON

Wind Turbine setbacks employed by various countries were considered. It was found that setbacks were determined for various reasons that include noise, flicker, turbine blade failure and wind effects. The distances (setbacks) varied based on these factors and were influenced by the type of infrastructure

Wind turbine setbacks varied for roads, power lines, dwellings, buildings and property and it was noted that the largest setbacks were employed for reasons of noise and flicker related issues [1-7]. Very few countries specified setbacks for power lines.

The literature survey [1-7], yielded information about studies and experiments were conducted to determine the distance that a broken fragment from a wind turbine might be thrown. Even though of low probability of hitting a power line [5.0×10^{-5}]^[8], the distances recorded were significant [750m]^[8]

Setbacks were thus introduced to prevent any damage to Eskom infrastructure.

CONTROLLED DISCLOSURE

When downloaded from the EDMS, this document is uncontrolled and the responsibility rests with the user to ensure it is in line with the authorised version on the system.

Wind turbines may also cause changes in wind patterns with turbulent effects behind the hub. These factors dictate the wind turbine setbacks specified in this document.

Concentrated solar plants and photovoltaic plants also can limit access into the substation for power lines of all voltages. A setback distance must therefore be employed to prevent the substation from being boxed in by these generation plants. These setback distances are specified in this document.

3.2 ESKOM REQUIRED SETBACKS

- Eskom requires a setback distance of 3 times the tip height of the wind turbine from the edge of the closest Eskom servitude (including vacant servitudes) for transmission lines.
- Eskom requires a setback distance of 1 times the tip height of the wind turbine from the edge of the closest Eskom servitude (including vacant servitudes) for distribution Lines.
- Eskom must be informed of any proposed wind turbine, concentrated solar plants and photovoltaic activity within a 5 km radius of a substation. No wind turbine structure shall be built within a 2 km radius of the closest point of the substation. Where concentrated solar plants and photovoltaic structures fall within a 2 km radius of the closest point of a substation, Eskom should be informed in writing during the planning phase of the construction of such plant or structure.
- Applicants must show that Eskom radio telecommunication systems (mainly microwave systems) will not be affected in any way by wind turbines.

CONTROLLED DISCLOSURE

When downloaded from the EDMS, this document is uncontrolled and the responsibility rests with the user to ensure it is in line with the authorised version on the system.

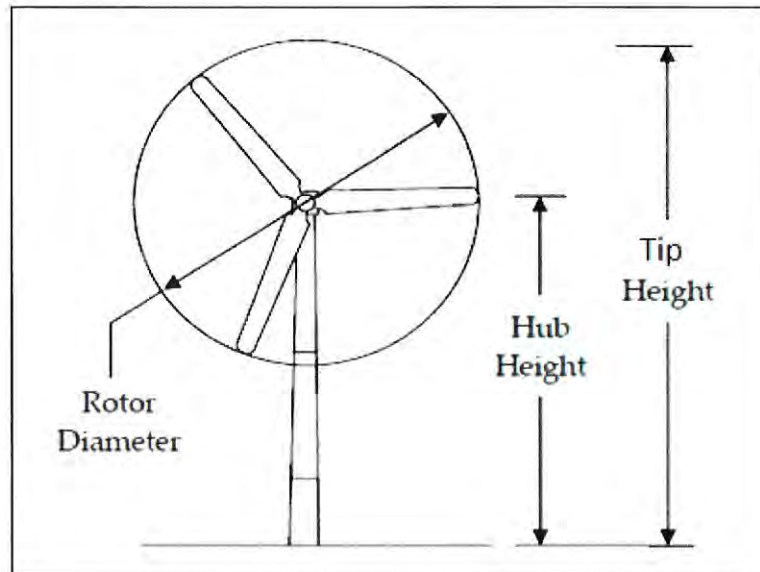

Figure 1: Horizontal Axis Wind Turbine ^[2]

4. AUTHORISATION

This document has been seen and accepted by:

Name & Surname	Designation
V Naidoo	Chief Engineer
Dr P H Pretorius	Electrical Specialist
J Geeringh	Snr Consultant Environ Mngt
B Haridass	Snr Consultant Engineer
R A Vajeth	Acting Snr Manager (Lines)

5. REVISIONS

Date	Rev.	Compiler	Remarks
November 2013	0	J W Chetty	First Publication - No renewable energy generation plant setback specification in existence

CONTROLLED DISCLOSURE

When downloaded from the EDMS, this document is uncontrolled and the responsibility rests with the user to ensure it is in line with the authorised version on the system.

6. DEVELOPMENT TEAM

The following people were involved in the development of this document:

Jonathan W Chetty (Mechanical Engineer)

Vivendhra Naidoo (Chief Engineer)

Dr Pieter H Pretorius (Electrical Specialist)

John Geeringh (Snr Consultant Environ Mngt)

Bharat Haridass (Snr Consultant Engineer)

Riaz A Vajeth (Acting Snr Manager (Lines))

CONTROLLED DISCLOSURE

When downloaded from the EDMS, this document is uncontrolled and the responsibility rests with the user to ensure it is in line with the authorised version on the system.

sivest_PPP

From: John Geeringh <GeerinJH@eskom.co.za>
Sent: 02 May 2017 12:59 PM
To: sivest_PPP
Subject: RE: Four Proposed Wind Farms near Loeriesfontein: EIA Commencing
Attachments: Eskom requirements for work in or near Eskom servitudes WIND (3).doc;
Renewable Energy Generation Plant Setbacks to Eskom Infrastructure - Signed.pdf

Please find attached the Eskom requirements for works at or near Eskom infrastructure for consideration during the EIA process.

Regards

John Geeringh (Pr. Sci. Nat.)
Senior Consultant Environmental Management

Eskom GC: Land Development
Megawatt Park
D1Y39
P O Box 1091
Johannesburg
2000

Tel: 011 516 7233
Fax: 086 661 4064
Cell: 083 632 7663

From: sivest_PPP [mailto:sivest_ppp@sivest.co.za]
Sent: 09 February 2017 03:51 PM
Cc: Andrea Gibb; 'Nicolene Venter'; Veronique Evans; Stephan Jacobs
Subject: Four Proposed Wind Farms near Loeriesfontein: EIA Commencing

***** Please note that this email was sent from a NO REPLY email address. Please do not reply to this address as it is an unmonitored email account.*****

Dear Stakeholder

ENVIRONMENTAL IMPACT ASSESSMENTS (EIAs) FOR THE PROPOSED DEVELOPMENT OF FOUR (4) WIND FARMS AND BASIC ASSESSMENTS (BAs) FOR THE ASSOCIATED GRID CONNECTION NEAR LOERIESFONTEIN, NORTHERN CAPE PROVINCE (DEA REFERENCE NUMBERS TO BE ANNOUNCED)

Please note that SiVEST SA (Pty) Ltd has been appointed as the independent Environmental Assessment Practitioner (EAP) by South Africa Mainstream Renewable Power Developments (Pty) Ltd to conduct the EIA processes for the proposed development of four (4) Wind Farms and the BA processes for the four (4) associated grid connections. The proposed projects are located in the Northern Cape Province near Loeriesfontein and are referred to as: Graskoppies Wind Farm, Xha! Boom Wind farm, Hartebeest Leegte Wind Farm, Ithemba Wind Farm, Graskoppies Grid Connection, Xha! Boom Grid Connection, Hartebeest Leegte Grid Connection and Ithemba Grid Connection.

Attached, for your attention are; the Background Information Document (BID), Invitation Letter and Registration and Comment Form for the proposed project. The documents are provided in English and Afrikaans for your convenience.

Kind Regards,

Andrea Gibb (B.Sc. Landscape Architecture; B.Sc.(Hons) Environmental Management)
Environmental Practitioner and Visual Specialist
SiVEST Environmental Division

SiVEST is a Level 3 BBBEE Contributor

Direct +27 11 798 0638 Tel +27 11 798 0600 fax +27 11 803 7272
email andreas@sivest.co.za website www.sivest.co.za

Consulting Engineers - Project Managers - Environmental Consultants - Town and Regional Planners
Durban - Johannesburg - Pietermaritzburg - Richards Bay - Ladysmith - Cape Town - Harare
(Zimbabwe)

Disclaimer

The information contained in this communication from the sender is confidential. It is intended solely for use by the recipient and others authorized to receive it. If you are not the recipient, you are hereby notified that any disclosure, copying, distribution or taking action in relation of the contents of this information is strictly prohibited and may be unlawful.

This email has been scanned for viruses and malware, and automatically archived by Mimecast SA (Pty) Ltd, an innovator in Software as a Service (SaaS) for business. Mimecast Unified Email Management ??? (UEM) offers email continuity, security, archiving and compliance with all current legislation. To find out more, [contact Mimecast](#).

NB: This Email and its contents are subject to the Eskom Holdings SOC Limited EMAIL LEGAL NOTICE which can be viewed at http://www.eskom.co.za/Pages/Email_Legal_Spam_Disclaimer.aspx

Eskom requirements for work at or near Eskom infrastructure.

1. Eskom's rights and services must be acknowledged and respected at all times.
2. Eskom shall at all times retain unobstructed access to and egress from its servitudes.
3. Eskom's consent does not relieve the developer from obtaining the necessary statutory, land owner or municipal approvals.
4. Any cost incurred by Eskom as a result of non-compliance to any relevant environmental legislation will be charged to the developer.
5. If Eskom has to incur any expenditure in order to comply with statutory clearances or other regulations as a result of the developer's activities or because of the presence of his equipment or installation within the servitude restriction area, the developer shall pay such costs to Eskom on demand.
6. The use of explosives of any type within 500 metres of Eskom's services shall only occur with Eskom's previous written permission. If such permission is granted the developer must give at least fourteen working days prior notice of the commencement of blasting. This allows time for arrangements to be made for supervision and/or precautionary instructions to be issued in terms of the blasting process. It is advisable to make application separately in this regard.
7. Changes in ground level may not infringe statutory ground to conductor clearances or statutory visibility clearances. After any changes in ground level, the surface shall be rehabilitated and stabilised so as to prevent erosion. The measures taken shall be to Eskom's satisfaction.
8. Eskom shall not be liable for the death of or injury to any person or for the loss of or damage to any property whether as a result of the encroachment or of the use of the servitude area by the developer, his/her agent, contractors, employees, successors in title, and assignees. The developer indemnifies Eskom against loss, claims or damages including claims pertaining to consequential damages by third parties and whether as a result of damage to or interruption of or interference with Eskom's services or apparatus or otherwise. Eskom will not be held responsible for damage to the developer's equipment.
9. No mechanical equipment, including mechanical excavators or high lifting machinery, shall be used in the vicinity of Eskom's apparatus and/or services, without prior written permission having been granted by Eskom. If such permission is granted the developer must give at least seven working days' notice prior to the commencement of work. This allows time for arrangements to be made for supervision and/or precautionary instructions to be issued by the relevant Eskom Manager

Note: Where and electrical outage is required, at least fourteen work days are required to arrange it.

10. Eskom's rights and duties in the servitude shall be accepted as having prior right at all times and shall not be obstructed or interfered with.
11. Under no circumstances shall rubble, earth or other material be dumped within the servitude restriction area. The developer shall maintain the area concerned to Eskom's satisfaction. The developer shall be liable to Eskom for the cost of any remedial action which has to be carried out by Eskom.
12. The clearances between Eskom's live electrical equipment and the proposed construction work shall be observed as stipulated by *Regulation 15 of the Electrical Machinery Regulations of the Occupational Health and Safety Act, 1993 (Act 85 of 1993)*.
13. Equipment shall be regarded electrically live and therefore dangerous at all times.
14. In spite of the restrictions stipulated by Regulation 15 of the Electrical Machinery Regulations of the Occupational Health and Safety Act, 1993 (Act 85 of 1993), as an additional safety precaution, Eskom will not approve the erection of houses, or structures occupied or frequented by human beings, under the power lines or within the servitude restriction area.
15. Eskom may stipulate any additional requirements to highlight any possible exposure to Customers or Public to coming into contact or be exposed to any dangers of Eskom plant.
16. It is required of the developer to familiarise himself with all safety hazards related to Electrical plant.
17. Any third party servitudes encroaching on Eskom servitudes shall be registered against Eskom's title deed at the developer's own cost. If such a servitude is brought into being, its existence should be endorsed on the Eskom servitude deed concerned, while the third party's servitude deed must also include the rights of the affected Eskom servitude.

John Geeringh (Pr Sci Nat)

Senior Consultant Environmental Management
Eskom GC: Land Development

Stephan Jacobs

From: Seoka Lekota <SLekota@environment.gov.za>
Sent: Monday, July 10, 2017 3:17 PM
To: sivist_PPP
Cc: Andrea Gibb; Stephan Jacobs; 'rebecca.thomas@mainstreamrp.com'; Stanley Tshitwamulomoni
Subject: RE: Four Proposed Wind Farms near Loeriesfontein: Revised BID

Good Day

Please note that request for comments should be send to us via registered mail and addressed to Directorate: Biodiversity Conservation and not to me directly since this might cause a delay in responding to your comments. It should be further noted that request for Biodiversity comments send via email would not be considered until an official registered mail with a hard copy or CD is received by the Directorate.

Hope the above is in order.

Regards

*Mr. Seoka Lekota [Pr.Sci.Nat.]
Department of Environmental Affairs
Directorate: Biodiversity Consaervation
Private Bag X447
PRETORIA
0001*

*Tel: +27(0)12 399 9573
E-mail: slekota@environment.gov.za*

From: sivist_PPP [mailto:sivist_ppp@sivist.co.za]
Sent: 19 June 2017 03:54 PM
Cc: Andrea Gibb; Stephan Jacobs; 'rebecca.thomas@mainstreamrp.com'
Subject: Four Proposed Wind Farms near Loeriesfontein: Revised BID

******* Please note that this email was sent from a NO REPLY email address. Please do not reply to this address as it is an unmonitored email account.*******

Dear Interested and/or Affected Party

ENVIRONMENTAL IMPACT ASSESSMENTS (EIAs) FOR THE PROPOSED DEVELOPMENT OF FOUR (4) WIND FARMS AND BASIC ASSESSMENTS (BAs) FOR THE ASSOCIATED GRID CONNECTION NEAR LOERIESFONTEIN, NORTHERN CAPE PROVINCE

- **Graskoppies Wind Farm – (DEA Ref No: To be announced)**
- **Xha! Boom Wind Farm – (DEA Ref No: To be announced)**
- **Hartebeest Leegte Wind Farm – (DEA Ref No: To be announced)**
- **Ithemba Wind Farm – (DEA Ref No: To be announced)**
- **Graskoppies Grid Connection – (DEA Ref No: To be announced)**
- **Xha! Boom Grid Connection – (DEA Ref No: To be announced)**

- **Hartebeest Leegte Grid Connection – (DEA Ref No: To be announced)**
- **Ithemba Grid Connection – (DEA Ref No: To be announced)**

Please note that SiVEST SA (Pty) Ltd was appointed by South Africa Mainstream Renewable Power Developments (Pty) Ltd as the Environmental Assessment Practitioner (EAP) for the above mentioned projects. In October 2016, all interested and/or affected parties (I&APs) were invited to participate in the Environmental Impact Assessment (EIA) processes for the wind farm developments and the Basic Assessment (BA) processes for the associated grid connections and were sent a Background Information Document (BID). Since this communication there have been some changes to the proposed developments which include the following;

- The addition of a new power line assessment corridor;
- A change in the generation capacity of the wind farms; and
- A change in the maximum hub height and rotor diameter.

As such, the BID has been updated based on the above changes and is attached for your perusal.

Kindly note that the Draft Scoping Reports (DSRs) will be available for public comment in June 2017 and you will be notified accordingly.

Kind Regards

Geagte Belangstellende en/of Geaffekteerde Party

OMGEWINGSIMPAAKEVALUERINGS (OIE's) VIR DIE BEOOGDE ONTWIKKELING VAN VIER (4) WINDPLASE EN BASIESE EVALUERINGS (BE's) VIR DIE GEPAAARDGAANDE ROOSTERKONNEKSIES NABY LOERIESFONTEIN, NOORD-KAAPPROVINSIE

- **Graskoppies Windplaas – (DO Verw. No.: Moet nog aangekondig word)**
- **Xha! Boom Windplaas – (DO Verw. No.: Moet nog aangekondig word)**
- **Hartebeest Leegte Windplaas – (DO Verw. No.: Moet nog aangekondig word)**
- **Ithemba Windplaas – (DO Verw. No.: Moet nog aangekondig word)**
- **Graskoppies Roosterkonneksie – (DO Verw. No.: Moet nog aangekondig word)**
- **Xha! Boom Roosterkonneksie – (DO Verw. No.: Moet nog aangekondig word)**
- **Hartebeest Leegte Roosterkonneksie – (DO Verw. No.: Moet nog aangekondig word)**
- **Ithemba Roosterkonneksie – (DO Verw. No.: Moet nog aangekondig word)**

Neem asseblief kennis dat South Africa Mainstream Renewable Power Developments (Edms.) Bpk. vir SiVEST SA (Edms.) Bpk. aangestel het as die Omgewingsevalueringspraktisyn (OEP) vir die bogenoemde projekte. In Oktober 2016 is alle belangstellende en/of geaffekteerde partye (B&GP's) genooi om deel te neem aan die Omgewingsimpakevalueringsprosesse (OIE-prosesse) vir die windplaasontwikkelings en die Basiese Evalueeringsprosesse (BE-prosesse) vir die gepaardgaande roosterkonneksies en 'n Agtergrondinligtingsdokument (AID) is aan hulle gestuur. Sedert hierdie skrywe was daar sekere veranderinge aan die beoogde ontwikkelings wat die volgende insluit:

- Die byvoeging van 'n nuwe kraglynkorridor vir evaluering;
- 'n verandering aan die opwekkingsvermoë van die windplase; en
- 'n verandering aan die maksimum naafhoogte en rotordeursnee.

Die AID is dienooreenkomstig bygewerk op grond van die bogenoemde veranderinge en aangeheg vir u insae.

Let asseblief daarop dat die Konsep Bestekopnameverslae (KBV's) in Junie 2017 beskikbaar sal wees vir openbare kommentaar en u sal dienooreenkomstig verwittig word.

Vriendelike groete

Kind Regards,

Andrea Gibb (*B.Sc. Landscape Architecture; B.Sc.(Hons) Environmental Management*)
Environmental Practitioner and Visual Specialist
SiVEST Environmental Division

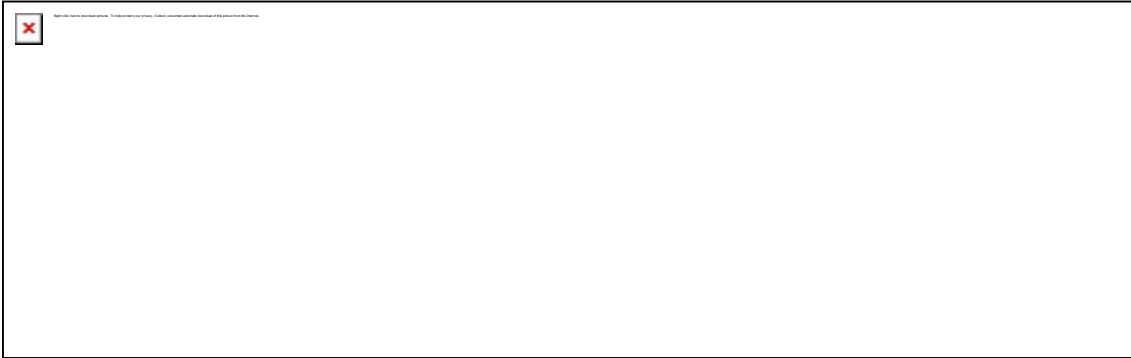



SIVEST



SIVEST is a Level 3 BBBEE Contributor

Direct +27 11 798 0638 **Tel** +27 11 798 0600 **fax** +27 11 803 7272
email andreag@sivest.co.za **website** www.sivest.co.za

Consulting Engineers - Project Managers - Environmental Consultants - Town and Regional Planners
Durban - Johannesburg - Pietermaritzburg - Richards Bay - Ladysmith - Cape Town - Harare (Zimbabwe)

Disclaimer

The information contained in this communication from the sender is confidential. It is intended solely for use by the recipient and others authorized to receive it. If you are not the recipient, you are hereby notified that any disclosure, copying, distribution or taking action in relation of the contents of this information is strictly prohibited and may be unlawful.

This email has been scanned for viruses and malware, and automatically archived by **Mimecast SA (Pty) Ltd**, an innovator in Software as a Service (SaaS) for business. **Mimecast Unified Email Management ??? (UEM)** offers email continuity, security, archiving and compliance with all current legislation. To find out more, [contact Mimecast](#).

Please consider the environment before you print this email. Only print if it is essential. A message from the Department of Environmental Affairs.

Please consider the environment before you print this email. Only print if it is essential. A message from the Department of Environmental Affairs.

This message and any attachments transmitted with it are intended solely for the addressee(s) and may be legally privileged and/or confidential. If you have received this message in error please destroy it and notify the sender. Any unauthorized usage, disclosure, alteration or dissemination is prohibited. The Department of Environmental Affairs accepts no responsibility for any loss whether it be direct, indirect or consequential, arising from information made available and actions resulting there from. The views and opinions expressed in this e-mail message may not necessarily be those of Management.

Hlengiwe Ntuli

From: Adeyileka Esther Thivhonalali(KBY) <AdeyilekaE@dws.gov.za>
Sent: 25 July 2017 04:04 PM
To: Hlengiwe Ntuli
Cc: Sekwaila Kwena Khutjo (KBY); Mahlako Richard (KBY); Damane Refilwe (KBY); Moalosi Kelebogile(KBY)
Subject: Wind Farm EIA X4

Good day;

The proposed applications fall in the Lower orange, i have given the document to Lebo so that LO (copied) staff can assist you further.

Regards;
Esther

DISCLAIMER: This message and any attachments are confidential and intended solely for the addressee. If you have received this message in error, please notify the system manager/sender. Any unauthorized use, alteration or dissemination is prohibited. The Department of Water and Sanitation further accepts no liability whatsoever for any loss, whether it be direct, indirect or consequential, arising from this e-mail, nor for any consequence of its use or storage.

sivest_PPP

From: Harry Roberts <RobertsH@caa.co.za>
Sent: 25 July 2017 10:28 AM
To: sivest_PPP
Subject: Automatic reply: Four Proposed Mainstream Wind Farms near Loeriesfontein: DSR Comment Period Ended

Dear Client, as My contract reaches maturity on the 31st August 2017, I will no longer be available to assist with your queries, from that date. In order to ensure continuity of service, please address all correspondence intended for my desk to Obstacles@caa.co.za, from where it will be accessed and acted upon accordingly. Direct urgent enquiries to Mr Werner Kleynhans 011 545 1468

Regards
Harry Roberts

This email has been scanned for email related threats and delivered safely by Mimecast.
For more information please visit <http://www.mimecast.com>

Hlengiwe Ntuli

From: Sekwaila Kwena Khutjo (KBY) <SekwailaK@dws.gov.za>
Sent: 08 August 2017 02:11 PM
To: Hlengiwe Ntuli
Cc: Mahlako Richard (KBY); Damane Refilwe (KBY)
Subject: RE: Wind Farm EIA X4

Afternoon,

Please note that you can contact us once you are ready to proceed with the application.

A meeting and site inspection will be required for start.

Regards

Khutjo Sekwaila (Pr.Sci.Nat.)
Department of Water and Sanitation
Orange – Proto CMA
Northern Cape Region: Kimberley
Office: B32
28 Central Road, Beaconsfield, 8301
Tel: 053 836 7609



From: Hlengiwe Ntuli [mailto:HlengiweN@sivest.co.za]
Sent: Thursday, 27 July 2017 10:02 AM
To: Sekwaila Kwena Khutjo (KBY)
Cc: Mahlako Richard (KBY); Damane Refilwe (KBY)
Subject: RE: Wind Farm EIA X4

Good Day Kwena,

Please note that the four wind farms are located approximately 70km north of Loeriesfontein in the Northern Cape Province.

Please also find attached the regional locality map for each project.

Kind Regards,

Hlengiwe Ntuli

Projects Secretary and PPP Administrator
SiVEST Environmental Division



SiVEST is a Level 3 BBBEE Contributor

 **Direct** +27 11 798 0690 **Tel** +27 11 798 0600 **fax** +27 11 803 7272
email hengiwen@sivest.co.za **website** www.sivest.co.za

Consulting Engineers - Project Managers - Environmental Consultants - Town and Regional Planners
Durban - Johannesburg - Pietermaritzburg - Richards Bay - Ladysmith - Port Louis (Mauritius)

From: Sekwaila Kwena Khutjo (KBY) [mailto:SekwailaK@dws.gov.za]
Sent: 26 July 2017 01:49 PM
To: Hlengiwe Ntuli <HlengiweN@sivest.co.za>
Cc: Mahlako Richard (KBY) <MahlakoR@dws.gov.za>; Damane Refilwe (KBY) <DamaneR@dws.gov.za>
Subject: RE: Wind Farm EIA X4

Afternoon,

Can you please help us help you by informing us where the proposed project will be based?

Regards

Khutjo Sekwaila (Pr.Sci.Nat.)
Department of Water and Sanitation
Orange – Proto CMA
Northern Cape Region: Kimberley
Office: B32
28 Central Road, Beaconsfield, 8301
Tel: 053 836 7609

CLEAR RIVERS during Mandela Month 2017

Visit our website to find out how you can get involved and support the
CLEAR RIVERS campaign - www.dws.gov.za

WATER IS LIFE - SANITATION IS DIGNITY



water & sanitation
Department:
Water and Sanitation
REPUBLIC OF SOUTH AFRICA



From: Hlengiwe Ntuli [mailto:HlengiweN@sivest.co.za]
Sent: Wednesday, 26 July 2017 10:04 AM
To: Adeyileka Esther Thivhonali(KBY)
Cc: Sekwaila Kwena Khutjo (KBY); Mahlako Richard (KBY); Damane Refilwe (KBY); Moalosi Kelebogile(KBY)
Subject: RE: Wind Farm EIA X4

Good Morning Ester,

Thanks a lot for your comments.

Will forward to the relevant department.

Kind Regards,

Hlengiwe Ntuli
Projects Secretary and PPP Administrator
SiVEST Environmental Division



SiVEST is a Level 3 BBBEE Contributor



Direct +27 11 798 0690 Tel +27 11 798 0600 fax +27 11 803 7272
email hlengiwen@sivest.co.za website www.sivest.co.za

Consulting Engineers - Project Managers - Environmental Consultants - Town and Regional Planners
Durban - Johannesburg - Pietermaritzburg - Richards Bay - Ladysmith - Port Louis (Mauritius)

From: Adeyileka Esther Thivhionali(KBY) [<mailto:AdeyilekaE@dws.gov.za>]

Sent: 25 July 2017 04:04 PM

To: Hlengiwe Ntuli <HlengiweN@sivest.co.za>

Cc: Sekwaila Kwena Khutjo (KBY) <SekwailaK@dws.gov.za>; Mahlako Richard (KBY) <MahlakoR@dws.gov.za>;
Damane Refilwe (KBY) <DamaneR@dws.gov.za>; Moalosi Kelebogile(KBY) <MoalosiK2@dws.gov.za>

Subject: Wind Farm EIA X4

Good day;

The proposed applications fall in the Lower orange, i have given the document to Lebo so that LO (copied) staff can assist you further.

Regards;
Esther

DISCLAIMER: This message and any attachments are confidential and intended solely for the addressee. If you have received this message in error, please notify the system manager/sender. Any unauthorized use, alteration or dissemination is prohibited. The Department of Water and Sanitation further accepts no liability whatsoever for any loss, whether it be direct, indirect or consequential, arising from this e-mail, nor for any consequence of its use or storage.

Disclaimer

The information contained in this communication from the sender is confidential. It is intended solely for use by the recipient and others authorized to receive it. If you are not the recipient, you are hereby notified that any disclosure, copying, distribution or taking action in relation of the contents of this information is strictly prohibited and may be unlawful.

This email has been scanned for viruses and malware, and automatically archived by Mimecast SA (Pty) Ltd, an innovator in Software as a Service (SaaS) for business. Mimecast Unified Email Management ??? (UEM) offers email continuity, security, archiving and compliance with all current legislation. To find out more, [contact Mimecast](#).

DISCLAIMER: This message and any attachments are confidential and intended solely for the addressee. If you have received this message in error, please notify the system manager/sender. Any unauthorized use, alteration or dissemination is prohibited. The Department of Water and Sanitation further accepts no liability whatsoever for any loss, whether it be direct, indirect or consequential, arising from this e-mail, nor for any consequence of its use or storage.

Disclaimer

The information contained in this communication from the sender is confidential. It is intended solely for use by the recipient and others authorized to receive it. If you are not the recipient, you are hereby notified that any disclosure, copying, distribution or taking action in relation of the contents of this information is strictly prohibited and may be unlawful.

This email has been scanned for viruses and malware, and automatically archived by Mimecast SA (Pty) Ltd, an innovator in Software as a Service (SaaS) for business. Mimecast Unified Email Management ??? (UEM) offers email continuity, security, archiving and compliance with all current legislation. To find out more, [contact Mimecast](#).

DISCLAIMER: This message and any attachments are confidential and intended solely for the addressee. If you have received this message in error, please notify the system manager/sender. Any unauthorized use, alteration or dissemination is prohibited. The Department of Water and Sanitation further accepts no liability whatsoever for any loss, whether it be direct, indirect or consequential, arising from this e-mail, nor for any consequence of its use or storage.

Reference: EIA/L/2017_response 1

Queries: Kensani Mangena

51 Wessel Road
Rivonia
PO Box 2921
Rivonia
2128

28 June 2017

Per email: hlengiwen@sivest.co.za / stephanj@sivest.co.za

For Attention: Hlengiwe Ntuli and Stephan Jacobs

cc: Kensani Mangena (k.mangena@sanbi.org.za)
Sagwata Manyike (S.Manyike@sanbi.org.za)

Please note that the South African National Biodiversity Institute (SANBI) did not register as an Interested and Affected Party (I&AP) for the following applications: NEMA ref No: 13622. SANBI kindly requests that you remove it as an I&AP for the above mentioned applications.

Please note that SANBI only participates in applications for Environmental Authorisation as an I&AP if the application is for a development on a SANBI property or a property adjacent to a SANBI property, or if the application would impact on an area that has been highlighted as a priority implementation area within one of SANBI's Bioregional Programmes.

SANBI thus kindly declines to participate in this application as an I&AP at this point in time.

SANBI is a public entity mandated to act in an advisory or consultative capacity on matters relating to biodiversity to the Department of Environmental Affairs (i.e. the 'competent authority'). The Department and its provincial counterparts are welcome to engage SANBI for advice and/or comment on specific matters related to biodiversity information relevant to this application, if such input is required. Such advice or comment is not equivalent, however, to the comment required as per the NEMA regulations from commenting authorities. SANBI restricts its comment to the accuracy and relevance of the biodiversity information that should inform the Environmental Assessment.

SANBI thus also declines to participate as a commenting authority in this application. For comment on the biodiversity impacts of the development, please consult the relevant provincial conservation agency.

I also encourage you to visit our web portal <http://biodiversityadvisor.sanbi.org> for free access to spatial biodiversity information relevant for land-use planning and decision-making processes.

Referencing the spatial biodiversity resources found on the Biodiversity Advisor in the **early stages** of project development can support informed planning and decision-making while helping to timeously 'iron out' obstacles that might otherwise result in delays and additional costs to the project proponent.

Such a proactive approach can:

- Show the decision-making authority that potential conflict between biodiversity priorities and other land-uses has been identified and resolved by well-informed project planning;
- Allow the proponent to take an informed decision about the biodiversity (and administrative and, by implication, financial) risks of proceeding with a particular project; and
- Identify the scope, type and intensity of environmental assessment that is likely to be required if an application were to proceed.

This approach also supports best practice in environmental assessment and planning by:

- Ensuring that a project is consistent with the 'Duty of Care' principle (i.e. that the project proponent has taken reasonable measures to prevent significant degradation of the environment);
- Emphasising the fundamental role of alternatives in selecting the best practicable environmental option;
- Giving effect to the mitigation hierarchy, i.e. the sequential avoidance, minimising, mitigating and remedying of impacts that may result in loss of biodiversity or disturbance to ecosystems; and
- Supporting the principle that environmental management must pay specific attention to planning procedures pertaining to sensitive, vulnerable, highly dynamic or stressed ecosystems.

Please feel free to contact me should you require any assistance or have any queries re: using the resources on our <http://biodiversityadvisor.sanbi.org> web portal.

Yours sincerely



Sagwata Manyike
Specialist Advisor: Planning & Land Use Management
South African National Biodiversity Institute
Email: S.Manyike@sanbi.org.za
Tel: +27 12 843 5105



BirdLife South Africa is a partner of BirdLife International, a global partnership of nature conservation organisations.
Member of IUCN (International Union for Conservation of Nature).
Reg No: 001 – 298 NPO
PBO Exemption No: 930004518

30 November 2017

Andrea Gibb
Sivest
Email: AndreaG@sivest.co.za

RE: COMMENT ON THE DRAFT ENVIRONMENTAL IMPACT ASSESSMENTS (EIAs) FOR THE PROPOSED DEVELOPMENT OF FOUR (4) WIND FARMS NEAR LOERIESFONTEIN, NORTHERN CAPE PROVINCE

- **Hartebeest Leegte Wind Farm – DEA Ref No: 14/12/16/3/3/2/1015**
- **Ithemba Wind Farm – DEA Ref No: 14/12/16/3/3/2/1016**
- **Graskoppies Wind Farm – DEA Ref No: 14/12/16/3/3/2/1017**
- **Xha! Boom Wind Farm – DEA Ref No: 14/12/16/3/3/2/10**

Thank you for the opportunity to comment on the above reports. BirdLife South Africa supports the responsible development of renewable energy, however there are many unanswered questions relating to the potential significance of the impacts of the above wind farms on birds and their habitats.

Although a number of other species may be affected (e.g. Burchell's Courser, Ludwig's Bustard Karoo Korhaan and Sclater's Lark), much of our uncertainty relates to the risk of negative effects on Red Lark (listed as Vulnerable in the Red Data Book of Birds of South Africa Lesotho and Swaziland). Our concern is based on the limited range of this threatened species and risk of cumulative impacts. Based on our rough calculations, the combined footprint of renewable energy developments around the Helios Main Transmission Station alone could affect approximately 6% of the Red Lark distribution. The Renewable Energy Development Zone could result in further impacts within the species' range.

A better understanding of the significance of the habitat for Red Lark would be valuable. South African Bird Atlas Project 2 (SABAP2) reporting rates in the area for Red Lark are high. These high reporting rates might simply be as result of the number of intensive bird surveys in the area associated with renewable energy developments, with the surrounding areas are not as well surveyed. SABAP 1 data, which is older and at a much coarser scale than SABAP 1, does suggest a wider distribution for the species.

The avifaunal study for the project reports bird density using a measure of relative abundance, i.e. Index of Kilometric Abundance, and it difficult to compare these results with other published data (e.g. Dean et al. 1991). While the use of Index of Kilometric Abundance is accepted by BirdLife South Africa's Best Practice Guidelines (Jenkins et al. 2015), the Guidelines do suggest that this sampling approach should be complemented by calculations of absolute abundance. The latter is more likely to detect subtle changes in abundance, which could be useful to assess the relative sensitivity of different parts of the proposed development footprint (e.g. to guide the layout), and for comparing the impacts of the facility before and after development. Across the site(s) species' distribution and abundance was only assessed using "visual inspection" and we suggest that a more quantitative approach would have been useful.

While the abundance of Red Larks on site may be lower on site than in in some other areas assessed for renewable energy development, it is possible this is in part as result of averaging the abundance over a large area where the actual abundance is patchy.

Isidell House, 17 Hume Road
Dunkeld West, Gauteng 2196
Private Bag X5000, Parklands
Johannesburg, Gauteng 2121, South Africa
Tel: +27 (0)11 789 1122
Fax: +27 (0)11 789 5188
Email: info@birdlife.org.za
www.birdlife.org.za





BirdLife South Africa is a partner of BirdLife International, a global partnership of nature conservation organisations.
Member of IUCN (International Union for Conservation of Nature).
Reg No: 001 – 298 NPO
PBO Exemption No: 930004518

Abundance not also the only factor worth considering when assessing the conservation value of an area. While the core of the species distribution, the Koa Valley, undoubtedly warrants protection, the proposed development area and surrounds do appear to support a viable population of Red Lark, and forms the south-western boundary of the species range.

There is also uncertainty regarding the susceptibility of Red Larks to the impacts associated with wind energy. Only once wind farms have been built and monitored will we be able to make confident predictions around displacement and disturbance effects, and the risk of fatalities (from turbine-strikes and traffic collisions). It may be possible to minimise the risk of collisions with turbine blades by increasing the distance between the blade-tip and the ground (as has been proposed), possibly combined with curtailment during high-risk periods. However, the details of these approaches to mitigation require further interrogation; the mitigation measures proposed in the EIA are vague and open-ended. We also suggest that the applicant should clarify if the proposed measures, under the worst-case scenario, are considered to be feasible and that the financial and operational implications have been adequately assessed and planned for.

In light of the above uncertainties, combined with the number of wind farms already approved within Red Lark habitat, BirdLife South Africa would be more comfortable with a precautionary approach - i.e. only consider further development of wind farms within Red Lark habitat once there is more information both with regards to which areas are of most conservation and the risk that wind energy presents to the species. Some of this work is already underway (for example monitoring at Loeriesfontein Wind Farm and BirdLife South Africa is developing an ecological niche model for the Red Lark).

Should these wind farms be approved despite BirdLife South Africa's concerns, we strongly recommend that the distance between the blade-tip and the ground be maximized. This will benefit Red Lark, as well as many other low flying birds. We also suggest that fatality rate thresholds for Red Lark and other threatened species should be defined and agreed to within this EIA; should these thresholds be exceeded the wind farm(s) must be required to curtail turbines during high-risk periods (e.g. breeding displays and after good rains). Operational phase monitoring should include rigorous assessment of how Red Lark's are affected by turbines, including possible displacement and disturbance effects. Lastly, we suggest that in order to compensate for any impacts that may occur and with the goal of having a net positive impact on biodiversity, wind farms in the area should collaborate to enhance and protect conservation of priority species the surrounding area.

Lastly, we note that the transmission-line will be assessed in a separate application. We urge that the impacts on species such as Ludwig's Bustard are not overlooked, as these impacts will be difficult to mitigate. The extent of new lines should therefore be minimised.

Yours sincerely

Samantha Ralston-Paton
Birds and Renewable Energy Project Manager



BirdLife South Africa is a partner of BirdLife International, a global partnership of nature conservation organisations.
Member of IUCN (International Union for Conservation of Nature).
Reg No: 001 – 298 NPO
PBO Exemption No: 930004518

Control less Red Larks...
Monitoring protocols red lark

Cumulative impacts

Ludwigs

“low” was <30m

> 10% of SABAP 1 pentads gave development, not including potential development in Springbok REDZ

Visual inspection of habitat preferences should go further .

Close inspection of Red Lark records indicates a possible preference for sandy areas, although the species was also recorded in gravel plains, although in lower numbers.

Mitigation feasible?

and a commitment from the site operator to implement curtailment during periods of high flight activity, e.g. after good rains which triggers breeding activity, should significant mortality be recorded

Criteria agreed to, nebulous

net gain

The Index of Kilometric Abundance is a valid measure of abundance, which is provided for in the most recent BLSA guidelines on pre-construction monitoring. This Index is considered an adequate and appropriate measure of abundance for the purposes of assessing impacts in the EIA, and for the purpose of establishing a baseline against which subsequent operational monitoring results can be compared.

The area around the Helios Main Transmission Station has become a hub for renewable energy development

the transmission-line will be assessed in a separate application. We urge that the impacts on species such as Ludwig's Bustard are not overlooked, as these impacts will be difficult to mitigate. The extent of new lines should therefore be minimised



BirdLife South Africa is a partner of BirdLife International, a global partnership of nature conservation organisations.
Member of IUCN (International Union for Conservation of Nature).

Reg No: 001 – 298 NPO
PBO Exemption No: 930004518

sivest_PPP

From: Samantha Ralston-Paton <energy@birdlife.org.za>
Sent: 30 November 2017 05:58 PM
To: sivest_PPP
Subject: Re: Four Proposed Mainstream Wind Farms near Loeriesfontein: DEIAr Comment Period Starting
Attachments: BLSA Grasskoppies EIA comments.pdf; PastedGraphic-2.pdf; PastedGraphic-1.tiff; PastedGraphic-2.tiff

Good Day
Please see our comments attached.
Kind regards
Sam

Samantha Ralston-Paton
Birds and Renewable Energy Manager



Room A8
Centre for Biodiversity Conservation Kirstenbosch Botanical Gardens
Newlands
Cape Town
7700
Cell: +27 (0) 83 673 3948
E-mail: energy@birdlife.org.za
<http://www.birdlife.org.za>

Follow me on Twitter: [@SamRalstonPaton](https://twitter.com/SamRalstonPaton)

[Sign up to my mailing list](#)

+++++

SMS 'birdlife' to 38878 and help Give Conservation Wings

R10 per SMS. Free SMS and SMS bundles do not apply. All proceeds, less service provider fees, will be donated to BirdLife South Africa. Error messages will be billed. More details on BirdLife South Africa website.

Donations to BirdLife South Africa may contribute to your B-BBEE scorecard as we are fully SED compliant in terms of the B-BBEE Act. We are also a registered Public Benefit Organisation (No. 930004518) and authorised to issue 18A tax certificates where applicable.

On 31 Oct 2017, at 3:48 PM, sivist_PPP <sivist_ppp@sivist.co.za> wrote:

******* Please note that this email was sent from a NO REPLY email address. Please do not reply to this address as it is an unmonitored email account.*******

Dear Interested and/or Affected Party

ENVIRONMENTAL IMPACT ASSESSMENTS (EIAs) FOR THE PROPOSED DEVELOPMENT OF FOUR (4) WIND FARMS NEAR LOERIESFONTEIN, NORTHERN CAPE PROVINCE

- Hartebeest Leegte Wind Farm – DEA Ref No: 14/12/16/3/3/2/1015
- Ithemba Wind Farm – DEA Ref No: 14/12/16/3/3/2/1016
- Graskoppies Wind Farm – DEA Ref No: 14/12/16/3/3/2/1017
- Xha! Boom Wind Farm – DEA Ref No: 14/12/16/3/3/2/1018

SiVEST SA (Pty) Ltd was previously appointed by South Africa Mainstream Renewable Power Developments (Pty) Ltd as the Environmental Assessment Practitioner (EAP) for the above mentioned projects.

We would like to take this opportunity to inform you that, in accordance with the National Environmental Management Act (NEMA) (as amended), the Draft Environmental Impact Assessment Reports (DEIARs) for the above mentioned projects will be available for public comment and review as from **Tuesday 31 October 2017 to Thursday 30 November 2017** (end of business day). Should you wish to receive an electronic copy of the DEIARs (on CD) please forward your request in writing to us. Hard copies of the DSRs can be reviewed at the following public place:

VENUE	STREET ADDRESS	HOURS	CONTACT NO
Loeriesfontein Library	Main Street, Loeriesfontein	Mondays- Fridays 14h00 – 17h00	027 662 8607

The report is also available on SiVEST's website: <http://www.sivest.co.za/>, click on 'Downloads' then browse to the folder '13622 Mainstream Wind Farms'.

Attached is an English and Afrikaans letter notifying of the review period.
Kind Regards
Andrea Gibb
Senior Manager

SiVEST Environmental Division

<Picture (Device Independent Bitmap) 1.jpg>

SiVEST is a Level 3 BBBEE Contributor

Direct +27 11 798 0638 **Tel** +27 11 798 0600 **fax** +27 11 803 7272
email andreaq@sivest.co.za **website** www.sivest.co.za

Consulting Engineers - Project Managers - Environmental Consultants - Town and Regional Planners
Durban - Johannesburg - Pietermaritzburg - Richards Bay - Ladysmith - Cape Town - Harare (Zimbabwe)

Disclaimer

The information contained in this communication from the sender is confidential. It is intended solely for use by the recipient and others authorized to receive it. If you are not the recipient, you are hereby notified that any disclosure, copying, distribution or taking action in relation of the contents of this information is strictly prohibited and may be unlawful.

This email has been scanned for viruses and malware, and automatically archived by Mimecast SA (Pty) Ltd, an innovator in Software as a Service (SaaS) for business. Mimecast Unified Email Management (UEM) offers email continuity, security, archiving and compliance with all current legislation. To find out more, [contact Mimecast](#).

<13622 Mainstream DEIAR Notification Rev1 31 October 2017 AG.PDF><13622
Mainstream DEIAR Notification Rev1 31 October 2017 AG (Afrikaans).pdf>



PO Box 9
Observatory 7935
South Africa
Tel: 021 447 0025
Fax: 021 447 3639
Int. Code: +27
rrs@sao.ac.za

www.sao.ac.za

04 December 2017

Nicolene Venter
Public Participation and Stakeholder Engagement Practitioner
Imaginative Africa (Pty) Ltd
PO Box 61164
PIERRE VAN RYNEVELD, 0157

Dear Ms. Venter

PROPOSED 4 MAINSTREAM WIND FARMS AND ASSOCIATED GRID LINE CONNECTION NEAR LOERIESFONTEIN, NORTHERN CAPE PROVINCE

The proposed four Mainstream Wind Farms and Associated Grid Line Connection near Loeriesfontein, Northern Cape Province, are considerably far from Sutherland and outside of the declared Sutherland Central Astronomy Advantage Area. We don't think that the facilities will have any measurable impact on optical astronomy at the Southern African Large Telescope (SALT) at the South African Astronomical Observatory (SAAO) observing station near Sutherland. Our main concern as optical astronomy research facility are related to impacts from light and dust that may be generated during development and operation of wind farms. Light and dust pollution negatively affect the quality of optical observations.

Yours sincerely

Dr RR Sefako
Head of Telescope Operations, SAAO

Hlengiwe Ntuli

From: Ramotholo Sefako <rrs@sao.ac.za>
Sent: Monday, 04 December 2017 3:06 PM
To: nicolene@imaginativeafrica.co.za
Cc: Andrea Gibb; Stephan Jacobs; Shaun Taylor; Hlengiwe Ntuli; Ted Williams; Petri Vaisanen; Chris Coetzee
Subject: Re: EIA: Proposed 4 Mainstream Wind Farms and Associated Grid Line Connection near Loeriesfontein, Northern Cape Province
Attachments: Mainstream2017.pdf

Dear Ms Venter

Attached is the SAAO comments regarding your proposed four Mainstream Wind Farms and associated grid line connections near Loeriesfontein, Northern Cape.

Regards
Ramotholo

Dr Ramotholo Sefako
Head of Telescope Operations (TOPS)
South African Astronomical Observatory
PO Box 9, Observatory, 7935, South Africa
Tel: +27 21 460 9344 (work)
eMail: rrs@sao.ac.za



The DR&PW

Department:
Roads & Public Works
NORTHERN CAPE PROVINCE
REPUBLIC OF SOUTH AFRICA

DIRECTOR: ROADS
PO Box 3132, KIMBERLEY, 8301
45 Schmidtsdrift Road
KIMBERLEY, 8301
Tel: 053 861 9600
Fax: 053 861 9626

Reference Number: L2.1.2.9.5 – DR2977-DR2972-OG240/PL/1117

Enquires: C.Ndubula /M. Sithole

Date: 13 November 2017

Mainstream Renewable Power

PO Box 45063

Claremont

7735 Cape Town

RE: APPLICATION FOR 132KV GRID LINE ALONG AND OVER DR2972 AND DR2977

Refer to your application dated 02 October 2017.

The Department of Roads and Public Works (DRPW) does not have objections against your application, subject to the following conditions that must be complied with at all times in case of any work undertaken within the statutory road reserve or within a distance of 95 meters from the centerline of any building restriction road (advertising on Roads and Ribbon Development Act, no.21 of 1940) and within the statutory road reserve or within 5 meters from the statutory boundary of any public road (Roads Ordinance, 19 of 1976).

1. The applicant must submit a detailed layout design for approval prior to any works (the proposed 132kV grid line). The designs must include but not limited to; The offset distance referencing from the centerline of the road, height clearance and etc...
2. The roads that will be affected by your proposal are DR2972, DR2977 and OG240.
3. The applicant must investigate all the existing services (sewer lines, pipelines, underground cables and overhead cables) passing through or alongside that specific (proposed works) area.
4. Poles or towers carrying power lines in excess of 22kV must be erected outside the statutory road width and not closer than 50 meters to the centerline of the road concerned.

5. In cases where an overhead power line crosses a public road:
 - a) The poles and/or towers must comply with the distances and road clearance as per Eskom Standards and;
 - b) Provision must be made for a vertical clearance as prescribed by the Factories, Machinery and Building Act, 1941 but in any case not less than 8 meters measured from the highest point of the road to the lowest wire or safety net.
6. All excavations within the statutory road width will be reinstated by the applicant to the satisfaction of the District Roads Engineer concerned.
7. If any fence along the road boundaries is removed by the applicant or is damaged through his activities, it must be restored to the original standard.
10. This response letter does not exempt the applicant from complying with any other law that may be applicable to the proposed work and related activities

SIGNED at Kimberley this 13 day of November 2017



J Roelofse (Director: Roads Planning and Design)
For and on behalf of

THE DEPARTMENT OF ROADS AND PUBLIC WORKS NORTHERN CAPE

REGISTRY
RECEIVED
2017 -11- 13
DEPT. ROADS & PUBLIC WORKS
PO Box 3132, Kimberley 8300

Minor Road 240

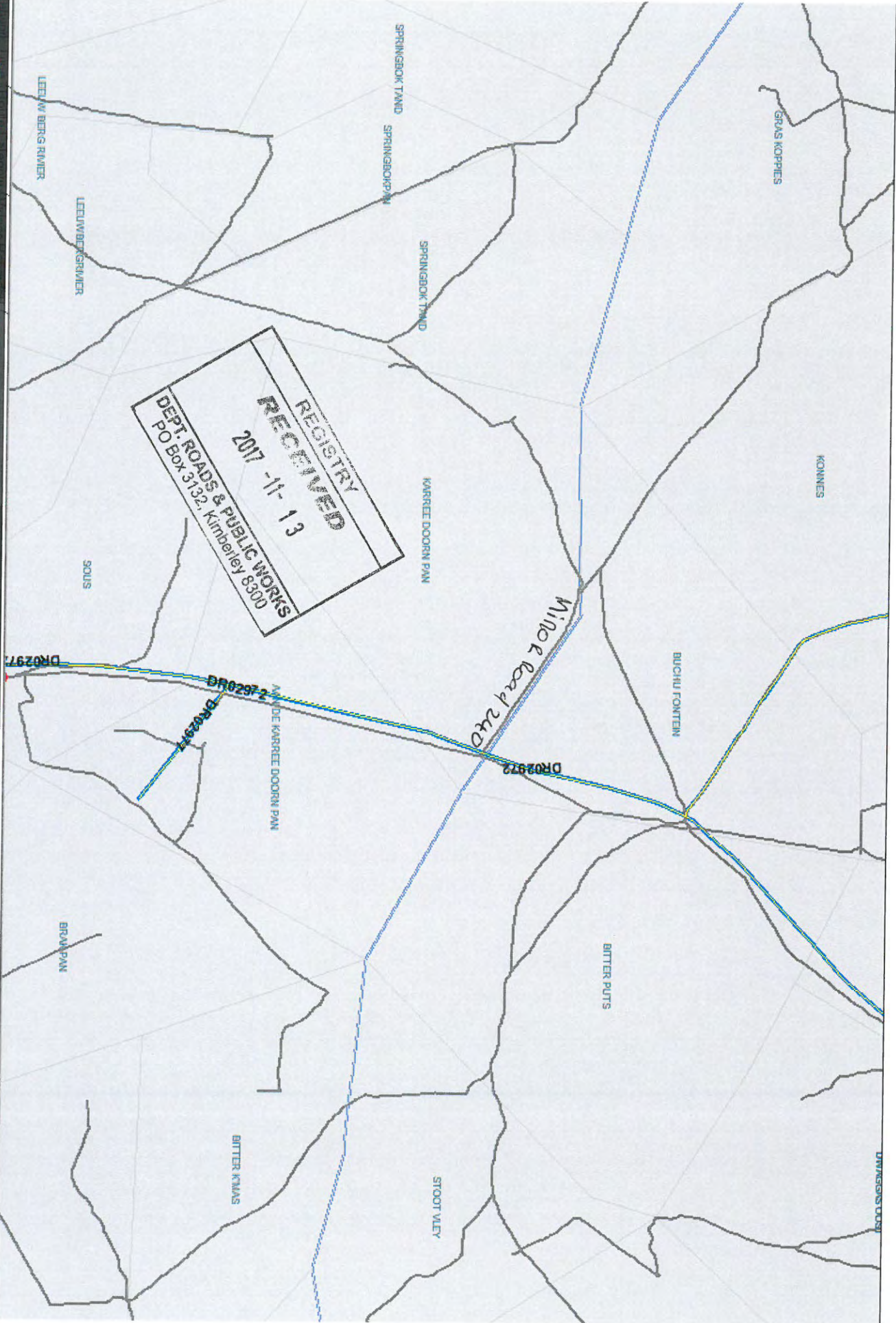

DR0297

DR0297

DR0297

DR0297

BRAMPAN

DINGSBOS

Andrea Gibb

Subject: FW: E-mail from Hantam LM FW: Loeriesfontein Son/windplase

From: Riana Lock - Admin2 (Hantam Municipality) [<mailto:admin2@hantam.gov.za>]

Sent: Tuesday, December 12, 2017 8:41 AM

To: Nicolene Venter <nicolene@imaginativeafrica.co.za>

Cc: 'Jl.Swartz-Municipal Manager(Hantam Municipality)' <municipalmanager@hantam.gov.za>

Subject: Loeriesfontein Son/windplase

Goeiedag Nicolene

Hiermee wil ek graag by jou verneem wie almal die rolspelers is by die nuwe ontwikkeling by Loeriesfontein. Die Munisipale Bestuurder wil so vroeg as kan in Januarie 2018 'n vergadering met die betrokke partye he. Sal bly wees as jy my so spoedig moontlik kan voorsien van die name/adresse/kontakbesonderhede.

Baie dankie. Mooi dag.

Riana Lock
Hantam

Stephan Jacobs

From: Natasha Higgitt <nhiggitt@sahra.org.za>
Sent: Friday, December 15, 2017 8:04 AM
To: Andrea Gibb; Stephan Jacobs
Subject: Re: Proposed Mainstream Substations and Power Lines for the Wind Farms near Loeriesfontein: DBARs Available for Review

Good morning,

Thank you for the notification. Please ensure that all the relevant documents are uploaded to an application on SAHRIS so that an official comment can be issued.

Kind Regards,

Natasha Higgitt
Heritage Officer: Archaeology, Palaeontology and Meteorites Unit

South African Heritage Resources Agency
- A nation united through heritage -

T: +27 21 462 4502 | F: +27 21 462 4509 | C: +27 82 507 0378
E: nhiggitt@sahra.org.za | 111 Harrington Street | Cape Town

www.sahra.org.za

Please note that SAHRA will be closed from the 27th December 2017 and will reopen on the 2 January 2018

Natasha Higgitt
Heritage Officer: Archaeology, Palaeontology and Meteorites Unit

South African Heritage Resources Agency
- A nation united through heritage -

T: +27 21 462 4502 | C: +27 82 507 0378 | F: +27 21 462 4509
E: nhiggitt@sahra.org.za | 111 Harrington Street | Cape Town | 8001

www.sahra.org.za



From: "sivest_PPP" <sivest_ppp@sivest.co.za>
To: "Andrea Gibb" <AndreaG@sivest.co.za>, "Stephan Jacobs" <StephanJ@sivest.co.za>, "rebecca.thomas@mainstreamrp.com" <rebecca.thomas@mainstreamrp.com>, "Nicolene Venter" <nicolene@imaginativeafrica.co.za>
Cc: "John Geeringh" <GeerinJH@eskom.co.za>, "Heleen van den Heever" <vdheevhd@telkom.co.za>, "Morgan Griffiths" <morgan.griffiths@wessa.co.za>, "Obakeng Isaacs" <munman@khaima.gov.za>, "P Josop" <commonage@khaima.gov.za>, "Brian Fisher" <bfisher@ncpg.gov.za>, "Henning Myburg" <henning@agrink.co.za>, "Sam Fiff" <Francis.Rahlapane@transnet.net>, "Amanda Bester" <WayleaCR@telkom.co.za>, "Riaan Van Wyk" <socialdev1@hantam.gov.za>, "Natasha Higgitt" <nhiggitt@sahra.org.za>, "Nicole Abrahams"

<AbrahamsN@nra.co.za>, "Ted Williams" <williams@saa.ac.za>, "Chris Coetzee" <chris@salt.ac.za>, "Hettie Buys" <HettieB@daff.gov.za>, "Thoko Buthelezi" <ThokoB@daff.gov.za>, "Mmatlala Rabothata" <mrabothata@environment.gov.za>, "Marianne Golding" <marianneg@ewt.org.za>, "Simphiwe Masilela" <ObstacleEvaluators@atns.co.za>, "Candice Stevens" <advocacy@birdlife.org.za>, "Johanna Morobane" <JohannaM@atns.co.za>, "Lizell Stroh" <strohl@caa.co.za>, "Adriaan Tiplady" <atiplady@ska.ac.za>, "Ramatholo Sefako" <rrs@saa.ac.za>, "Samantha Ralston-Paton" <energy@birdlife.org.za>, "Gert Steenkamp" <gsteenkamp@ncpg.gov.za>, "Moses Mahunonyane" <MahunonyaneM@dws.gov.za>, "Johan Koegelenberg" <KoegelenbergJ@sentech.co.za>, "Lourens Leeuwner" <lourensl@ewt.org.za>, "Stanley Tshitwamulomoni" <StanleyT@environmental.gov.za>, "Candice Spammer" <spammec1@telkom.co.za>, "Seoka Lekota" <slekota@environment.gov.za>, "Jaco Roelofse" <roelofse.j@vodamail.co.za>, "Patrick Lenyibi" <plenyibi@ncpg.gov.za>, "Ester Makungo" <makungoe@dws.gov.za>, "Garth Julius" <JuliusG@nra.co.za>, "Jannie Loubser" <janniel@namakwa-dm.gov.za>, "ruth.cuttings@yahoo.com" <ruth.cuttings@yahoo.com>, "kmotlhomini@ncpg.gov.za" <kmotlhomini@ncpg.gov.za>, "lefleurd@dws.gov.za" <lefleurd@dws.gov.za>, "BesterAD@telkom.co.za" <BesterAD@telkom.co.za>

Sent: Thursday, 14 December, 2017 4:54:07 PM

Subject: Proposed Mainstream Substations and Power Lines for the Wind Farms near Loeriesfontein: DBARs Available for Review

******* Please note that this email was sent from a NO REPLY email address. Please do not reply to this address as it is an unmonitored email account.*******

BASIC ASSESSMENTS (BAS) FOR THE PROPOSED DEVELOPMENT OF THE 132KV MAINSTREAM LINKING SUBSTATION AND FOUR (4) 132KV ON-SITE ESKOM SUBSTATIONS AND POWER LINES NEAR LOERIESFONTEIN, NORTHERN CAPE PROVINCE

- **132kV Graskoppies Substations and Power line – (DEA Ref No.: To be Announced)**
- **132kV Hartbeest Leegte Substations and Power Line – (DEA Ref No.: To be Announced)**
- **132kV Ithemba Substations and Power Line – DEA Ref No.: To be Announced)**
- **132kV !Xha Boom Substations and Power Line – DEA Ref No.: To be Announced)**

SiVEST is in the process of undertaking the Basic Assessments (BAs) for the proposed development of the above-mentioned Substations and Power Lines near Loeriesfontein in the Northern Cape Province.

We would like to take this opportunity to inform you that, in accordance with the National Environmental Management Act (NEMA) (as amended), the Draft Basic Assessment Reports (DBARs) will be made available for public comment and review as from **Thursday 14 December 2017 to Monday 05 February 2018** (before end of business day).

The DBARs as well as the accompanying appendices are available online (<http://www.sivest.co.za/> click on 'Downloads' and navigate to '13622 Mainstream Substations and Power Lines') and an electronic copy (on CD) has been posted to you. We kindly request that you submit your comments to Public Participation Office at the below details, on or before **Monday 05 February 2018** (before end of business day). SiVEST will forward any comments received after the public comment and review period directly to the relevant case officer at the Department of Environmental Affairs (DEA).

Should you have any questions or queries please do not hesitate to contact us at:

Stephan Jacobs / Hlengiwe Ntuli

PO BOX 2921, Rivonia, 2128

Tel – (011) 798 0600

Fax – (011) 803 7272

Email – stephanj@sivest.co.za /
hlengiwen@sivest.co.za

Kind Regards

Andrea Gibb

Senior Manager

SiVEST Environmental Division





SIVEST is a Level 3 BBBEE Contributor

Direct +27 11 798 0638 **Tel** +27 11 798 0600 **fax** +27 11 803 7272
email andrea@sivest.co.za **website** www.sivest.co.za

Consulting Engineers - Project Managers - Environmental Consultants - Town and Regional Planners
Durban - Johannesburg - Pietermaritzburg - Richards Bay - Ladysmith - Cape Town - Harare (Zimbabwe)

Disclaimer

The information contained in this communication from the sender is confidential. It is intended solely for use by the recipient and others authorized to receive it. If you are not the recipient, you are hereby notified that any disclosure, copying, distribution or taking action in relation of the contents of this information is strictly prohibited and may be unlawful.

This email has been scanned for viruses and malware, and automatically archived by **Mimecast SA (Pty) Ltd**, an innovator in Software as a Service (SaaS) for business. **Mimecast Unified Email Management ??? (UEM)** offers email continuity, security, archiving and compliance with all current legislation. To find out more, [contact Mimecast](#).

This electronic communication and its content(s) are subject to a disclaimer which can be accessed here: <http://mail.sahra.org.za/disclaimer.html>



sivest_PPP

From: Riana Lock - Admin2 (Hantam Municipality) <admin2@hantam.gov.za>
Sent: 20 December 2017 08:40 AM
To: sivest_PPP
Subject: RE: 13622 Proposed Substations and Power Lines for the Wind Farms near Loeriesfontein: DBAR Comment Period Starting

Baie dankie. Kan ek asseblief die kontakbesonderhede/naam/nommer kry.

From: sivest_PPP [mailto:sivest_ppp@sivest.co.za]
Sent: 14 December 2017 04:49 PM
Cc: Andrea Gibb <AndreaG@sivest.co.za>; Stephan Jacobs <StephanJ@sivest.co.za>; 'rebecca.thomas@mainstreamrp.com' <rebecca.thomas@mainstreamrp.com>; 'Nicolene Venter' <nicolene@imaginativeafrica.co.za>
Subject: 13622 Proposed Substations and Power Lines for the Wind Farms near Loeriesfontein: DBAR Comment Period Starting

******* Please note that this email was sent from a NO REPLY email address. Please do not reply to this address as it is an unmonitored email account.*******

Dear Interested and/or Affected Party,

BASIC ASSESSMENTS (BAS) FOR THE PROPOSED DEVELOPMENT OF THE 132kV MAINSTREAM LINKING SUBSTATION AND FOUR (4) 132kV ON-SITE ESKOM SUBSTATIONS AND POWER LINES NEAR LOERIESFONTEIN, NORTHERN CAPE PROVINCE

- **132kV Graskoppies Substations and Power line**
– (DEA Ref No.: To be Announced)
- **132kV Hartebeest Leegte Substations and Power Line**
– (DEA Ref No.: To be Announced)
- **132kV Ithemba Substations and Power Line**
– (DEA Ref No.: To be Announced)
- **132kV !Xha Boom Substations and Power Line**
– (DEA Ref No.: To be Announced)

- **AVAILABILITY OF THE DRAFT BASIC ASSESSMENT REPORTS FOR PUBLIC REVIEW**

SiVEST is in the process of undertaking the Basic Assessments (BAs) for the proposed development of the above mentioned Substations and Power Lines near Loeriesfontein in the Northern Cape Province.

We would like to inform you that, in accordance with the National Environmental Management Act (NEMA) (as amended), the Draft Basic Assessment Reports (DBARs) for the above-mentioned projects will be made available for public review and comment as from **Thursday 14 December 2017 to Monday 05 February 2018** (before end of business day). Hard copies of the DBARs are available at the following venue:

VENUE	STREET ADDRESS	HOURS	CONTACT NO
--------------	-----------------------	--------------	-------------------

The reports as well as the accompanying appendices are also available on SiVEST's website: <http://www.sivest.co.za/>, click on downloads, then browse to the folder '13622 Mainstream Substations and Power Lines'.

Attached are English and Afrikaans letters notifying you of the availability of the reports, including Comment Forms.

We kindly request that you submit your comments to Public Participation Office at the below details, on or before **Monday 05 February 2018** (before end of business day). SiVEST will forward any comments received after the public comment and review period directly to the relevant case officer at the Department of Environmental Affairs (DEA).

Should you have any questions or queries please do not hesitate to contact us at:

Stephan Jacobs / Hlengiwe Ntuli

PO BOX 2921, Rivonia, 2128

Tel – (011) 798 0600

Fax – (011) 803 7272

Email – stephanj@sivest.co.za / hlengiwen@sivest.co.za

Kind Regards

ONDERWERP: 13622 Voorgestelde Substasies en Kraglyne vir doe Windplase naby Loeriesfontein: KBEV
Kommentaar Periode Begin

Geagte Belangstellende en/of Geaffekteerde Party,

**BASIESE EVALUERINGS (BE's) VIR DIE BEOOGDE ONTWIKKELING VAN DIE 132KV MAINSTREAM SKAKEL
SUBSTASIE EN VIER (4) 132KV OP PERSEEL ESKOM SUBSTASIES EN KRAGLYNE NABY LOERIESFONTEIN,
NOORD-KAAP PROVINSIE**

- **132kV Graskoppies Substasies en Kraglyn**
– (DEA Verwysings No.: Moet nog aangekondig word)
- **132kV Hartbeest Leegte Substasies en Kraglyn**
– (DEA Verwysings No.: Moet nog aangekondig word)
- **132kV Ithemba Substasies en Kraglyn**
– DEA Verwysings No.: Moet nog aangekondig word)
- **132kV !Xha Boom Substasies en Kraglyn**
– DEA Verwysings No.: Moet nog aangekondig word)
- **BESIKBAARHEID VAN DIE KONSEP BASIESE EVALUERINGSVERSLAE VIR OPENBARE OORSIG**

SiVEST is in die proses om die Basiese Evalueringe (BE's) vir die voorgestelde ontwikkeling van die bogenoemde Substasies en Kraglyne naby Loeriesfontein in die Noord-Kaap Provinsie te onderneem.

Ons lig u graag hiermee in dat die Konsep Basiese Evalueringe (KBEV's) vir die bogenoemde projekte, ooreenkomstig die Nasionale Wet op Omgewingsbestuur (NEMA) (soos gewysig), vanaf **Donderdag 14 Desember 2017** tot **Maandag 05 Februarie 2018** (voor die einde van die werksdag) beskikbaar gemaak sal wees vir

openbare oorsig en kommentaar. Gedrukte kopieë van die KBEV's is beskikbaar by die plek wat hieronder genoem word:

PLEK	STRAATADRES	TYE	KONTAKNOMMER
Loeriesfontein Biblioteek	Mainstraat, Loeriesfontein	Maandae – Vrydae 14h00 – 17h00	027 662 8607

Die verslae sowel as die meegaande aanhangsels is ook beskikbaar op SiVEST se webwerf: <http://www.sivest.co.za>. Klik op 'Downloads' en soek dan vir die gids '13622 Mainstream Substations and Power Lines'.

Aangeheg is Engelse en Afrikaanse briewe wat u inlig oor die beskikbaarheid van die verslae, insluitende Kommentaarvorms.

Ons versoek u vriendelik om u kommentaar by die publieke deelnemende kantoor in te dien by die onderstaande besonderhede, voor of op **Maandag 05 Februarie 2018** (voor die einde van die werksdag). SiVEST sal enige kommentaar wat na die openbare kommentaar en oorsigperiode ontvang word, direk aan die betrokke saakbeampte by die Departement van Omgewingsake (DEA) stuur.

Indien u enige vrae of navrae het, moet asseblief nie huiwer om ons te kontak by:

Stephan Jacobs / Hlengiwe Ntuli

Posbus 2921, Rivonia, 2128

Tel – (011) 798 0600

Faks – (011) 803 7272

E-pos – stephanj@sivest.co.za / hlengiwen@sivest.co.za

Vriendelike groete,

Kind Regards

Andrea Gibb

Senior Manager

SiVEST Environmental Division





SIVEST is a Level 3 BBBEE Contributor

Direct +27 11 798 0638 **Tel** +27 11 798 0600 **fax** +27 11 803 7272
email andreaq@sivest.co.za **website** www.sivest.co.za

Consulting Engineers - Project Managers - Environmental Consultants - Town and Regional Planners
Durban - Johannesburg - Pietermaritzburg - Richards Bay - Ladysmith - Cape Town - Harare (Zimbabwe)

Disclaimer

The information contained in this communication from the sender is confidential. It is intended solely for use by the recipient and others authorized to receive it. If you are not the recipient, you are hereby notified that any disclosure, copying, distribution or taking action in relation of the contents of this information is strictly prohibited and may be unlawful.

This email has been scanned for viruses and malware, and automatically archived by Mimecast SA (Pty) Ltd, an innovator in Software as a Service (SaaS) for business. Mimecast Unified Email Management **???** (UEM) offers email continuity, security, archiving and compliance with all current legislation. To find out more, [contact Mimecast](#).

Stephan Jacobs

From: Natasha Higgitt <nhiggitt@sahra.org.za>
Sent: Wednesday, January 10, 2018 9:47 AM
To: Hlengiwe Ntuli
Cc: Stephan Jacobs; Andrea Gibb
Subject: Re: Proposed Mainstream Substations and Power Lines for the Wind Farms near Loeriesfontein: DBARs Available for Review

Good morning,

I have begun to review the cases below, and I have noted that the location of the projects has not been mapped on the GIS layer of the applications. Please complete this as soon as possible, as I will not be able to issue a Final Comment without a complete application.

Many thanks.

Kind Regards,

Natasha Higgitt
Heritage Officer: Archaeology, Palaeontology and Meteorites Unit

South African Heritage Resources Agency
- A nation united through heritage -

T: +27 21 462 4502 | F: +27 21 462 4509 | C: +27 82 507 0378
E: nhiggitt@sahra.org.za | 111 Harrington Street | Cape Town

www.sahra.org.za

Natasha Higgitt
Heritage Officer: Archaeology, Palaeontology and Meteorites Unit

South African Heritage Resources Agency
- A nation united through heritage -

T: +27 21 462 4502 | C: +27 82 507 0378 | F: +27 21 462 4509
E: nhiggitt@sahra.org.za | 111 Harrington Street | Cape Town | 8001

www.sahra.org.za



From: "Hlengiwe Ntuli" <HlengiweN@sivest.co.za>
To: "Stephan Jacobs" <StephanJ@sivest.co.za>, "Natasha Higgitt" <nhiggitt@sahra.org.za>, "Andrea Gibb" <AndreaG@sivest.co.za>
Sent: Tuesday, 19 December, 2017 8:58:02 AM
Subject: RE: Proposed Mainstream Substations and Power Lines for the Wind Farms near Loeriesfontein: DBARs Available for Review

Good Morning Natasha,

Please note that new applications for Mainstream Substations and Power Lines have been created and all the relevant documents are uploaded.

Case numbers are as follows: Graskoppies 12077, Hartbeest Leegte 12078, !Xha Boom 12081 and Ithemba 12082.

Kind Regards,

Hlengiwe Ntuli
Projects Secretary and PPP Administrator
SIVEST Environmental Division



SIVEST is a Level 3 BBBEE Contributor



Direct +27 11 798 0690 Tel +27 11 798 0600 Fax +27 11 803 7272

email HlengiweN@sivest.co.za website www.sivest.co.za

Consulting Engineers - Project Managers - Environmental Consultants - Town and Regional Planners - Quality Management Consultants
Durban - Johannesburg - Pretoria - Pietermaritzburg - Richards Bay - Port Louis (Mauritius)

SIVEST offices will be closing for the Christmas and New Year holiday season break from 16h00 on Wednesday, 20th December 2017 and will re-open at 08h00 on Monday, 8th January 2018

From: Stephan Jacobs
Sent: Friday, 15 December 2017 10:57 AM
To: Natasha Higgitt; Andrea Gibb
Cc: Hlengiwe Ntuli
Subject: RE: Proposed Mainstream Substations and Power Lines for the Wind Farms near Loeriesfontein: DBARs Available for Review
Importance: High

Good Morning Mrs Higgitt,

SIVEST is in the process of creating an application on SAHRIS and uploading the relevant documents and will notify you via email when this has been completed.

Kind Regards,

Stephan Jacobs (B.Sc.(Hons) Environmental Management and Analysis)
Environmental Consultant
SIVEST Environmental Division



SIVEST is a Level 3 BBBEE Contributor



Direct +27 11 798 0677 Tel +27 11 798 0600 fax +27 11 803 7272 cell +27 22 737 2114

email stephanj@sivest.co.za website www.sivest.co.za

Managers - Environmental Consultants - Town and Regional Planners - Quality Management Consultants
Durban - Johannesburg - Pretoria - Pietermaritzburg - Richards Bay - Port Louis (Mauritius)

SiVEST offices will be
closing for the

Christmas and New Year holiday season break from 16h00 on Wednesday, 20th December 2017
and will re-open at 08h00 on Monday, 8th January 2018

From: Natasha Higgitt [<mailto:nhiggitt@sahra.org.za>]
Sent: Friday, December 15, 2017 8:04 AM
To: Andrea Gibb; Stephan Jacobs
Subject: Re: Proposed Mainstream Substations and Power Lines for the Wind Farms near Loeriesfontein: DBARs Available for Review

Good morning,

Thank you for the notification. Please ensure that all the relevant documents are uploaded to an application on SAHRIS so that an official comment can be issued.

Kind Regards,

Natasha Higgitt
Heritage Officer: Archaeology, Palaeontology and Meteorites Unit

South African Heritage Resources Agency
- A nation united through heritage -

T: +27 21 462 4502 | F: +27 21 462 4509 | C: +27 82 507 0378
E: nhiggitt@sahra.org.za | 111 Harrington Street | Cape Town

www.sahra.org.za

Please note that SAHRA will be closed from the 27th December 2017 and will reopen on the 2 January 2018

Natasha Higgitt
Heritage Officer: Archaeology, Palaeontology and Meteorites Unit

South African Heritage Resources Agency
- A nation united through heritage -

T: +27 21 462 4502 | C: +27 82 507 0378 | F: +27 21 462 4509
E: nhiggitt@sahra.org.za | 111 Harrington Street | Cape Town | 8001

www.sahra.org.za



From: "sivest_PPP" <sivest_ppp@sivest.co.za>
To: "Andrea Gibb" <AndreaG@sivest.co.za>, "Stephan Jacobs" <StephanJ@sivest.co.za>,

"rebecca.thomas@mainstreamrp.com" <rebecca.thomas@mainstreamrp.com>, "Nicolene Venter" <nicolene@imaginativeafrica.co.za>

Cc: "John Geering" <GeerinJH@eskom.co.za>, "Heleen van den Heever" <vdheevhd@telkom.co.za>, "Morgan Griffiths" <morgan.griffiths@wessa.co.za>, "Obakeng Isaacs" <munman@khaima.gov.za>, "P Josop" <commonage@khaima.gov.za>, "Brian Fisher" <bfisher@ncpg.gov.za>, "Henning Myburg" <henning@agrink.co.za>, "Sam Fiff" <Francis.Rahlapane@transnet.net>, "Amanda Bester" <WayleaCR@telkom.co.za>, "Riaan Van Wyk" <socialdev1@hantam.gov.za>, "Natasha Higgitt" <nhiggitt@sahra.org.za>, "Nicole Abrahams" <AbrahamsN@nra.co.za>, "Ted Williams" <williams@saa.ac.za>, "Chris Coetzee" <chris@salt.ac.za>, "Hettie Buys" <HettieB@daff.gov.za>, "Thoko Buthelezi" <ThokoB@daff.gov.za>, "Mmatlala Rabothata" <mrabothata@environment.gov.za>, "Marianne Golding" <marianneg@ewt.org.za>, "Simphiwe Masilela" <ObstacleEvaluators@atns.co.za>, "Candice Stevens" <advocacy@birdlife.org.za>, "Johanna Morobane" <JohannaM@atns.co.za>, "Lizell Stroh" <strohl@caa.co.za>, "Adriaan Tiplady" <atiplady@ska.ac.za>, "Ramatholo Sefako" <rrs@saa.ac.za>, "Samantha Ralston-Paton" <energy@birdlife.org.za>, "Gert Steenkamp" <gsteenkamp@ncpg.gov.za>, "Moses Mahunonyane" <MahunonyaneM@dws.gov.za>, "Johan Koegelenberg" <KoegelenbergJ@sentech.co.za>, "Lourens Leeuwner" <lourensl@ewt.org.za>, "Stanley Tshitwamulomoni" <StanleyT@environmental.gov.za>, "Candice Spammer" <spammec1@telkom.co.za>, "Seoka Lekota" <slekota@environment.gov.za>, "Jaco Roelofse" <roelofse.j@vodamail.co.za>, "Patrick Lenyibi" <plenyibi@ncpg.gov.za>, "Ester Makungo" <makungoe@dws.gov.za>, "Garth Julius" <JuliusG@nra.co.za>, "Jannie Loubser" <janniel@namakwa-dm.gov.za>, "ruth.cuttings@yahoo.com" <ruth.cuttings@yahoo.com>, "kmotlhomini@ncpg.gov.za" <kmotlhomini@ncpg.gov.za>, "lefleurd@dws.gov.za" <lefleurd@dws.gov.za>, "BesterAD@telkom.co.za" <BesterAD@telkom.co.za>

Sent: Thursday, 14 December, 2017 4:54:07 PM

Subject: Proposed Mainstream Substations and Power Lines for the Wind Farms near Loeriesfontein: DBARs Available for Review

******* Please note that this email was sent from a NO REPLY email address. Please do not reply to this address as it is an unmonitored email account.*******

BASIC ASSESSMENTS (BAS) FOR THE PROPOSED DEVELOPMENT OF THE 132KV MAINSTREAM LINKING SUBSTATION AND FOUR (4) 132KV ON-SITE ESKOM SUBSTATIONS AND POWER LINES NEAR LOERIESFONTEIN, NORTHERN CAPE PROVINCE

- **132kV Graskoppies Substations and Power line – (DEA Ref No.: To be Announced)**
- **132kV Hartbeest Leegte Substations and Power Line – (DEA Ref No.: To be Announced)**
- **132kV Ithemba Substations and Power Line – DEA Ref No.: To be Announced)**
- **132kV !Xha Boom Substations and Power Line – DEA Ref No.: To be Announced)**

SiVEST is in the process of undertaking the Basic Assessments (BAs) for the proposed development of the above-mentioned Substations and Power Lines near Loeriesfontein in the Northern Cape Province.

We would like to take this opportunity to inform you that, in accordance with the National Environmental Management Act (NEMA) (as amended), the Draft Basic Assessment Reports (DBARs) will be made available for public comment and review as from **Thursday 14 December 2017 to Monday 05 February 2018** (before end of business day).

The DBARs as well as the accompanying appendices are available online (<http://www.sivest.co.za/> click on 'Downloads' and navigate to '*13622 Mainstream Substations and Power Lines*') and an electronic copy (on CD) has been posted to you. We kindly request that you submit your comments to Public Participation Office at the below details, on or before **Monday 05 February 2018** (before end of business day). SiVEST will forward any comments received after the public comment and review period directly to the relevant case officer at the Department of Environmental Affairs (DEA).

Should you have any questions or queries please do not hesitate to contact us at:

Stephan Jacobs / Hlengiwe Ntuli

PO BOX 2921, Rivonia, 2128

Tel – (011) 798 0600

Fax – (011) 803 7272

Email – stephanj@sivest.co.za /
hlengiwen@sivest.co.za

Kind Regards

Andrea Gibb

Senior Manager

SiVEST Environmental Division

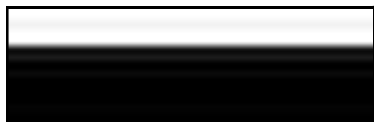



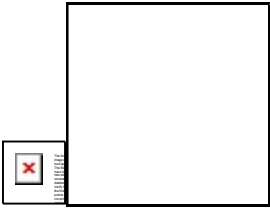

SIVEST is a Level 3 BBBEE Contributor

Direct +27 11 798 0638 **Tel** +27 11 798 0600 **fax** +27 11 803 7272
email andreag@sivest.co.za **website** www.sivest.co.za

Consulting Engineers - Project Managers - Environmental Consultants - Town and Regional Planners
Durban - Johannesburg - Pietermaritzburg - Richards Bay - Ladysmith - Cape Town - Harare (Zimbabwe)

Disclaimer

The information contained in this communication from the sender is confidential. It is intended solely for use by the recipient and others authorized to receive it. If you are not the recipient, you are hereby notified that any disclosure, copying, distribution or taking action in relation of the contents of this information is strictly prohibited and may be unlawful.

This email has been scanned for viruses and malware, and automatically archived by **Mimecast SA (Pty) Ltd**, an innovator in Software as a Service (SaaS) for business. **Mimecast Unified Email Management ??? (UEM)** offers email continuity, security, archiving and compliance with all current legislation. To find out more, [contact Mimecast](#).

This electronic communication and its content(s) are subject to a disclaimer which can be accessed here: <http://mail.sahra.org.za/disclaimer.html>

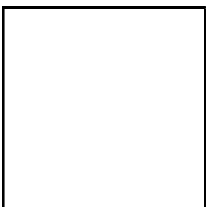

Disclaimer

The information contained in this communication from the sender is confidential. It is intended solely for use by the recipient and others authorized to receive it. If you are not the recipient, you are hereby notified that any disclosure, copying, distribution or taking action in relation of the contents of this information is strictly prohibited and may be unlawful.

This email has been scanned for viruses and malware, and automatically archived by **Mimecast SA (Pty) Ltd**, an innovator in Software as a Service (SaaS) for business. **Mimecast Unified Email Management ??? (UEM)** offers email continuity, security, archiving and compliance with all current legislation. To find out more, [contact Mimecast](#).

This electronic communication and its content(s) are subject to a disclaimer which can be accessed here: <http://mail.sahra.org.za/disclaimer.html>



sivest_PPP

From: JI.Swartz-Municipal Manager(Hantam Municipality)
<municipalmanager@hantam.gov.za>
Sent: 18 January 2018 03:08 PM
To: sivest_PPP
Cc: rebecca.thomas@mainstreamrp.com; rebecca.thomas@mainstreamrp.com
Subject: RE: Four Mainstream Wind Farms near Loeriesfontein: Submission of the Final Environmental Impact Assessment Reports

Goeiemiddag

Ofskoon vermelde prosesse ingevolge relevante wetgewing hanteer is, u versoek word om gesprek met ontwikkelaars te fasiliteer ten einde ander institusionele uitdagings wat die permit mag inhou uit te klaar.

Dit sal onverantwoordelik wees dat Hantam Munisipale raad nie 'n kans gegun word om die gevolge van enige toekomstige ontwikkeling op te klaar nie.

Ek hoop u vind dit in orde so.

Met dank

Jl Swartz
MUNISIPALE BESTUURDER

From: sivest_PPP [mailto:sivest_ppp@sivest.co.za]
Sent: Thursday, 18 January 2018 13:59
Cc: Andrea Gibb <AndreaG@sivest.co.za>; Stephan Jacobs <StephanJ@sivest.co.za>; 'Nicolene Venter' <nicolene@imaginativeafrica.co.za>; 'rebecca.thomas@mainstreamrp.com' <rebecca.thomas@mainstreamrp.com>
Subject: Four Mainstream Wind Farms near Loeriesfontein: Submission of the Final Environmental Impact Assessment Reports

******* Please note that this email was sent from a NO REPLY email address. Please do not reply to this address as it is an unmonitored email account. *******

Dear Interested and/or Affected Party / Stakeholder,

ENVIRONMENTAL IMPACT ASSESSMENTS (EIAs) FOR THE PROPOSED DEVELOPMENT OF FOUR (4) WIND FARMS NEAR LOERIESFONTEIN, NORTHERN CAPE PROVINCE

- **Hartebeest Leegte Wind Farm – DEA Ref No: 14/12/16/3/3/2/1015**
 - **Ithemba Wind Farm – DEA Ref No: 14/12/16/3/3/2/1016**
 - **Graskoppies Wind Farm – DEA Ref No: 14/12/16/3/3/2/1017**
 - **Xha! Boom Wind Farm – DEA Ref No: 14/12/16/3/3/2/1018**
-
- **SUBMISSION OF THE FINAL ENVIRONMENTAL IMPACT ASSESSMENT REPORTS**

Following the public comment and review period of the Draft Environmental Impact Assessment Reports (DEIARs) from **Tuesday 31 October 2017 to Thursday 30 November 2017** (end of business day) the DEIARs for the above-mentioned projects were updated, taking into consideration the issues and concerns raised by stakeholders, and the Final Environmental Impact Assessment Reports (FEIARs) were submitted to the Department of Environmental Affairs (DEA) on **Wednesday 17 January 2018**.

The reports are also available on SiVEST's website: <http://www.sivest.co.za/> click on 'Downloads' then browse to the folder '13622 Mainstream Wind Farms'.

We would like to thank you for your active and meaningful contribution to the EIA and Public Participation Process.

Geagte Belangstellende en/of Geaffekteerde Party / Belanghebbendes,

OMGEWINGSIMPAKEVALUERINGS (OIEs) VIR DIE BEOOGDE ONTWIKKELING VAN VIER (4) WINDPLASE NABY LOERIESFONTEIN, NOORD-KAAPPROVINSIE

- **Hartebeest Leegte Windplaas – DO Verw. No.: 14/12/16/3/3/2/1015**
- **Ithemba Windplaas – DO Verw. No.: 14/12/16/3/3/2/1016**
- **Graskoppies Windplaas – DO Verw. No.: 14/12/16/3/3/2/1017**
- **Xha! Boom Windplaas – DO Verw. No.: DEA Ref No: 14/12/16/3/3/2/1018**

- **INDIENING VAN DIE FINALE OMGEWINGEVALUERINGSVERSLAE BY DIE DEPARTEMENT VAN OMGEWINGSAKE**

Na aanleiding van die kommentaar deur die openbare oorsigtydperk van die Konsep Omgewingevalueeringsverslae (KOs) van **Dinsdag 31 Oktober 2017** tot **Donderdag 30 November 2017** (teen sluitingstyd), was die KOs vir die bogenoemde projekte bygewerk en gefinaliseer, met inagneming van die kwessies en kommentaar wat deur belanghebbendes opgewek is, en die Finale Omgewingevalueeringsverslae (FOs) was op **Woensdag 17 Januarie 2018** aan die Departement van Omgewingsake (DO) ingedien vir oorweging.

Die verslae is ook beskikbaar op SiVEST se webwerf: <http://www.sivest.co.za/> kliek op 'Downloads' en blaai dan na die gids '13622 Mainstream Wind Farms'.

Ons dank u by voorbaat vir u aktiewe en betekenisvolle bydrae tot die OIE- en Openbare Deelnameproses.

Kind Regards

Andrea Gibb

Senior Manager

SiVEST Environmental Division





SIVEST is a Level 3 BBBEE Contributor

Direct +27 11 798 0638 **Tel** +27 11 798 0600 **fax** +27 11 803 7272
email andrea@sivest.co.za **website** www.sivest.co.za

Consulting Engineers - Project Managers - Environmental Consultants - Town and Regional Planners
Durban - Johannesburg - Pietermaritzburg - Richards Bay - Ladysmith - Cape Town - Harare (Zimbabwe)

Disclaimer

The information contained in this communication from the sender is confidential. It is intended solely for use by the recipient and others authorized to receive it. If you are not the recipient, you are hereby notified that any disclosure, copying, distribution or taking action in relation of the contents of this information is strictly prohibited and may be unlawful.

This email has been scanned for viruses and malware, and automatically archived by Mimecast SA (Pty) Ltd, an innovator in Software as a Service (SaaS) for business. Mimecast Unified Email Management **???** (UEM) offers email continuity, security, archiving and compliance with all current legislation. To find out more, [contact Mimecast](#).

Stephan Jacobs

From: Natasha Higgitt <nhiggitt@sahra.org.za>
Sent: Thursday, January 18, 2018 4:26 PM
To: Hlengiwe Ntuli; Andrea Gibb
Cc: Stephan Jacobs
Subject: Re: Proposed Mainstream Substations and Power Lines for the Wind Farms near Loeriesfontein: DBARs Available for Review

Follow Up Flag: Follow up
Flag Status: Completed

Good afternoon,

Please note that a Final Comment has been issued on SAHRIS Case ID 12078. Please see link below:

<http://sahra.org.za/sahris/cases/proposed-construction-hartebeest-leegte-site-eskom-substation-and-power-line>

Please note that Interim Comments have been issued on SAHRIS Case ID 12077, 12081 and 12082. Please see links below:

<http://sahra.org.za/sahris/cases/graskoppies-site-eskom-substation-linking-substation-and-power-line>
<http://sahra.org.za/sahris/cases/proposed-construction-xha-boom-site-eskom-substation-and-power-line>
<http://sahra.org.za/sahris/cases/proposed-construction-ithemba-site-eskom-substation-and-power-line>

Kind Regards,

Natasha Higgitt
Heritage Officer: Archaeology, Palaeontology and Meteorites Unit

South African Heritage Resources Agency
- A nation united through heritage -

T: +27 21 462 4502 | F: +27 21 462 4509 | C: +27 82 507 0378
E: nhiggitt@sahra.org.za | 111 Harrington Street | Cape Town

www.sahra.org.za

Natasha Higgitt
Heritage Officer: Archaeology, Palaeontology and Meteorites Unit

South African Heritage Resources Agency
- A nation united through heritage -

T: +27 21 462 4502 | C: +27 82 507 0378 | F: +27 21 462 4509
E: nhiggitt@sahra.org.za | 111 Harrington Street | Cape Town | 8001

www.sahra.org.za



From: "Hlengiwe Ntuli" <HlengiweN@sivest.co.za>
To: "Natasha Higgitt" <nhiggitt@sahra.org.za>
Cc: "Stephan Jacobs" <StephanJ@sivest.co.za>, "Andrea Gibb" <AndreaG@sivest.co.za>
Sent: Wednesday, 10 January, 2018 4:23:53 PM
Subject: RE: Proposed Mainstream Substations and Power Lines for the Wind Farms near Loeriesfontein: DBARs Available for Review

Good Day Natasha,

The KML's have now been uploaded on both the GIS layer as well as additional documents on the last page.

Let me know if you require anything else.

Kind Regards,

Hlengiwe Ntuli

Projects Secretary and PPP Administrator

SiVEST Environmental Division



SiVEST is a Level 3 BBBEE Contributor



Direct +27 11 798 0690 **Tel** +27 11 798 0600 **fax** +27 11 803 7272

email hlengiwen@sivest.co.za **website** www.sivest.co.za

- Project Managers - Environmental Consultants - Town and Regional Planners

Consulting Engineers

Durban - Johannesburg - Pietermaritzburg - Richards Bay - Port Louis (Mauritius)

From: Natasha Higgitt [mailto:nhiggitt@sahra.org.za]
Sent: Wednesday, 10 January 2018 9:47 AM
To: Hlengiwe Ntuli
Cc: Stephan Jacobs; Andrea Gibb
Subject: Re: Proposed Mainstream Substations and Power Lines for the Wind Farms near Loeriesfontein: DBARs Available for Review

Good morning,

I have begun to review the cases below, and I have noted that the location of the projects has not been mapped on the GIS layer of the applications. Please complete this as soon as possible, as I will not be able to issue a Final Comment without a complete application.

Many thanks.

Kind Regards,

Natasha Higgitt
Heritage Officer: Archaeology, Palaeontology and Meteorites Unit

South African Heritage Resources Agency
- A nation united through heritage -

T: +27 21 462 4502 | F: +27 21 462 4509 | C: +27 82 507 0378
E: nhiggitt@sahra.org.za | 111 Harrington Street | Cape Town

www.sahra.org.za

Natasha Higgitt
Heritage Officer: Archaeology, Palaeontology and Meteorites Unit

South African Heritage Resources Agency
- A nation united through heritage -

T: +27 21 462 4502 | C: +27 82 507 0378 | F: +27 21 462 4509
E: nhiggitt@sahra.org.za | 111 Harrington Street | Cape Town | 8001

www.sahra.org.za



From: "Hlengiwe Ntuli" <HlengiweN@sivest.co.za>
To: "Stephan Jacobs" <StephanJ@sivest.co.za>, "Natasha Higgitt" <nhiggitt@sahra.org.za>, "Andrea Gibb" <AndreaG@sivest.co.za>
Sent: Tuesday, 19 December, 2017 8:58:02 AM
Subject: RE: Proposed Mainstream Substations and Power Lines for the Wind Farms near Loeriesfontein: DBARs Available for Review

Good Morning Natasha,

Please note that new applications for Mainstream Substations and Power Lines have been created and all the relevant documents are uploaded.

Case numbers are as follows: Graskoppies 12077, Hartbeest Leegte 12078, !Xha Boom 12081 and Ithemba 12082.

Kind Regards,

Hlengiwe Ntuli

Projects Secretary and PPP Administrator

SIVEST Environmental Division



SIVEST is a Level 3 BBBEE Contributor



Direct +27 11 798 0690 Tel +27 11 798 0600 Fax +27 11 803 7272

email HlengiweN@sivest.co.za website www.sivest.co.za

Consulting Engineers - Project Managers - Environmental Consultants - Town and Regional Planners - Quality Management Consultants

Durban - Johannesburg - Pretoria - Pietermaritzburg - Richards Bay - Port Louis (Mauritius)

SIVEST offices will be closing for the Christmas and New Year holiday season break from 16h00 on Wednesday, 20th December 2017

and will re-open at 08h00 on Monday, 8th January 2018

From: Stephan Jacobs
Sent: Friday, 15 December 2017 10:57 AM
To: Natasha Higgitt; Andrea Gibb
Cc: Hlengiwe Ntuli
Subject: RE: Proposed Mainstream Substations and Power Lines for the Wind Farms near Loeriesfontein: DBARs Available for Review
Importance: High

Good Morning Mrs Higgitt,

SIVEST is in the process of creating an application on SAHRIS and uploading the relevant documents and will notify you via email when this has been completed.

Kind Regards,

Stephan Jacobs (B.Sc.(Hons) Environmental Management and Analysis)

Environmental Consultant

SIVEST Environmental Division



SIVEST is a Level 3 BBEE Contributor



Direct +27 11 798 0677 **Tel** +27 11 798 0600 **fax** +27 11 803 7272 **cell** +27 72 737 2114

email stephanj@sivest.co.za **website** www.sivest.co.za

Consulting Engineers
- Project Managers - Environmental Consultants - Town and Regional Planners - Quality Management Consultants

Durban - Johannesburg - Pretoria - Pietermaritzburg - Richards Bay - Port Louis (Mauritius)

SIVEST offices will be closing for the Christmas and New Year holiday season break from 16h00 on Wednesday, 20th December 2017

and will re-open at 08h00 on Monday, 8th January 2018

From: Natasha Higgitt [<mailto:nhiggitt@sahra.org.za>]

Sent: Friday, December 15, 2017 8:04 AM

To: Andrea Gibb; Stephan Jacobs

Subject: Re: Proposed Mainstream Substations and Power Lines for the Wind Farms near Loeriesfontein: DBARs Available for Review

Good morning,

Thank you for the notification. Please ensure that all the relevant documents are uploaded to an application on SAHRIS so that an official comment can be issued.

Kind Regards,

Natasha Higgitt
Heritage Officer: Archaeology, Palaeontology and Meteorites Unit

South African Heritage Resources Agency
- A nation united through heritage -

T: +27 21 462 4502 | F: +27 21 462 4509 | C: +27 82 507 0378
E: nhiggitt@sahra.org.za | 111 Harrington Street | Cape Town

www.sahra.org.za

Please note that SAHRA will be closed from the 27th December 2017 and will reopen on the 2 January 2018

Natasha Higgitt
Heritage Officer: Archaeology, Palaeontology and Meteorites Unit

South African Heritage Resources Agency
- A nation united through heritage -

T: +27 21 462 4502 | C: +27 82 507 0378 | F: +27 21 462 4509
E: nhiggitt@sahra.org.za | 111 Harrington Street | Cape Town | 8001

www.sahra.org.za

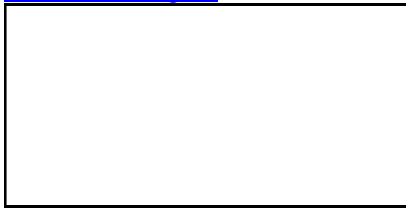

From: "sivest_PPP" <sivest_ppp@sivest.co.za>
To: "Andrea Gibb" <AndreaG@sivest.co.za>, "Stephan Jacobs" <StephanJ@sivest.co.za>, "rebecca.thomas@mainstreamrp.com" <rebecca.thomas@mainstreamrp.com>, "Nicolene Venter" <nicolene@imaginativeafrica.co.za>
Cc: "John Geering" <GeerinJH@eskom.co.za>, "Heleen van den Heever" <vdheevhd@telkom.co.za>, "Morgan Griffiths" <morgan.griffiths@wessa.co.za>, "Obakeng Isaacs" <munman@khaima.gov.za>, "P Josop" <commonage@khaima.gov.za>, "Brian Fisher" <bfisher@ncpg.gov.za>, "Henning Myburg" <henning@agrink.co.za>, "Sam Fiff" <Francis.Rahlapane@transnet.net>, "Amanda Bester" <WayleaCR@telkom.co.za>, "Riaan Van Wyk" <socialdev1@hantam.gov.za>, "Natasha Higgitt" <nhiggitt@sahra.org.za>, "Nicole Abrahams" <AbrahamsN@nra.co.za>, "Ted Williams" <williams@saa.ac.za>, "Chris Coetzee" <chris@salt.ac.za>, "Hettie Buys" <HettieB@daff.gov.za>, "Thoko Buthelezi" <ThokoB@daff.gov.za>, "Mmatlala Rabothata" <mrabothata@environment.gov.za>, "Marianne Golding" <marianneg@ewt.org.za>, "Simphiwe Masilela" <ObstacleEvaluators@atns.co.za>, "Candice Stevens" <advocacy@birdlife.org.za>, "Johanna Morobane" <JohannaM@atns.co.za>, "Lizell Stroh" <strohl@caa.co.za>, "Adriaan Tiplady" <atiplady@ska.ac.za>, "Ramatholo Sefako" <rrs@saa.ac.za>, "Samantha Ralston-Paton" <energy@birdlife.org.za>, "Gert Steenkamp" <gsteenkamp@ncpg.gov.za>, "Moses Mahunonyane" <MahunonyaneM@dws.gov.za>, "Johan Koegelenberg" <KoegelenbergJ@sentech.co.za>, "Lourens Leeuwner" <lourensl@ewt.org.za>,

"Stanley Tshitwamulomoni" <StanleyT@environmental.gov.za>, "Candice Spammer" <spammec1@telkom.co.za>, "Seoka Lekota" <slekota@environment.gov.za>, "Jaco Roelofse" <roelofse.j@vodamail.co.za>, "Patrick Lenyibi" <plenyibi@ncpg.gov.za>, "Ester Makungo" <makungoe@dws.gov.za>, "Garth Julius" <JuliusG@nra.co.za>, "Jannie Loubser" <janniel@namakwa-dm.gov.za>, "ruth.cuttings@yahoo.com" <ruth.cuttings@yahoo.com>, "kmotlhomi@ncpg.gov.za" <kmotlhomi@ncpg.gov.za>, "lefleurd@dws.gov.za" <lefleurd@dws.gov.za>, "BesterAD@telkom.co.za" <BesterAD@telkom.co.za>

Sent: Thursday, 14 December, 2017 4:54:07 PM

Subject: Proposed Mainstream Substations and Power Lines for the Wind Farms near Loeriesfontein: DBARs Available for Review

******* Please note that this email was sent from a NO REPLY email address. Please do not reply to this address as it is an unmonitored email account.*******

BASIC ASSESSMENTS (BAS) FOR THE PROPOSED DEVELOPMENT OF THE 132KV MAINSTREAM LINKING SUBSTATION AND FOUR (4) 132KV ON-SITE ESKOM SUBSTATIONS AND POWER LINES NEAR LOERIESFONTEIN, NORTHERN CAPE PROVINCE

- **132kV Graskoppies Substations and Power line – (DEA Ref No.: To be Announced)**
- **132kV Hartbeest Leegte Substations and Power Line – (DEA Ref No.: To be Announced)**
- **132kV Ithemba Substations and Power Line – DEA Ref No.: To be Announced)**
- **132kV !Xha Boom Substations and Power Line – DEA Ref No.: To be Announced)**

SiVEST is in the process of undertaking the Basic Assessments (BAs) for the proposed development of the above-mentioned Substations and Power Lines near Loeriesfontein in the Northern Cape Province.

We would like to take this opportunity to inform you that, in accordance with the National Environmental Management Act (NEMA) (as amended), the Draft Basic Assessment Reports (DBARs) will be made available for public comment and review as from **Thursday 14 December 2017 to Monday 05 February 2018** (before end of business day).

The DBARs as well as the accompanying appendices are available online (<http://www.sivest.co.za/> click on 'Downloads' and navigate to '*13622 Mainstream Substations and Power Lines*') and an electronic copy (on CD) has been posted to you. We kindly request that you submit your comments to Public Participation Office at the below details, on or before **Monday 05 February 2018** (before end of

business day). SiVEST will forward any comments received after the public comment and review period directly to the relevant case officer at the Department of Environmental Affairs (DEA).

Should you have any questions or queries please do not hesitate to contact us at:

Stephan Jacobs / Hlengiwe Ntuli

PO BOX 2921, Rivonia, 2128

Tel – (011) 798 0600

Fax – (011) 803 7272

Email – stephanj@sivest.co.za /

hlengiwen@sivest.co.za

Kind Regards

Andrea Gibb

Senior Manager

SiVEST Environmental Division





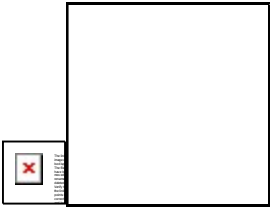

SIVEST is a Level 3 BBBEE Contributor

Direct +27 11 798 0638 **Tel** +27 11 798 0600 **fax** +27 11 803 7272

email andreaq@sivest.co.za **website** www.sivest.co.za

Consulting Engineers - Project Managers - Environmental Consultants - Town and Regional Planners

Durban - Johannesburg - Pietermaritzburg - Richards Bay - Ladysmith - Cape Town - Harare (Zimbabwe)

Disclaimer

The information contained in this communication from the sender is confidential. It is intended solely for use by the recipient and others authorized to receive it. If you are not the recipient, you are hereby notified that any disclosure, copying, distribution or taking action in relation of the contents of this information is strictly prohibited and may be unlawful.

This email has been scanned for viruses and malware, and automatically archived by **Mimecast SA (Pty) Ltd**, an innovator in Software as a Service (SaaS) for business. **Mimecast Unified Email Management ??? (UEM)** offers email continuity, security, archiving and compliance with all current legislation. To find out more, [contact Mimecast](#).

This electronic communication and its content(s) are subject to a disclaimer which can be accessed here: <http://mail.sahra.org.za/disclaimer.html>

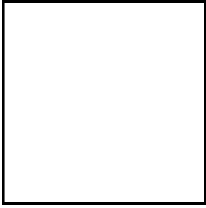

Disclaimer

The information contained in this communication from the sender is confidential. It is intended solely for use by the recipient and others authorized to receive it. If you are not the recipient, you are hereby notified that any disclosure, copying, distribution or taking action in relation of the contents of this information is strictly prohibited and may be unlawful.

This email has been scanned for viruses and malware, and automatically archived by **Mimecast SA (Pty) Ltd**, an innovator in Software as a Service (SaaS) for business. **Mimecast Unified Email Management ??? (UEM)** offers email continuity, security, archiving and compliance with all current legislation. To find out more, [contact Mimecast](#).

This electronic communication and its content(s) are subject to a disclaimer which can be accessed here: <http://mail.sahra.org.za/disclaimer.html>

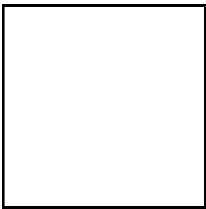

Disclaimer

The information contained in this communication from the sender is confidential. It is intended solely for use by the recipient and others authorized to receive it. If you are not the recipient, you are hereby notified that any disclosure, copying, distribution or taking action in relation of the contents of this information is strictly prohibited and may be unlawful.

This email has been scanned for viruses and malware, and automatically archived by **Mimecast SA (Pty) Ltd**, an innovator in Software as a Service (SaaS) for business. **Mimecast Unified Email Management ??? (UEM)** offers email continuity, security, archiving and compliance with all current legislation. To find out more, [contact Mimecast](#).

This electronic communication and its content(s) are subject to a disclaimer which can be accessed here: <http://mail.sahra.org.za/disclaimer.html>



Our Ref:



an agency of the
Department of Arts and Culture

T: +27 21 462 4502 | F: +27 21 462 4509 | E: info@sahra.org.za
South African Heritage Resources Agency | 111 Harrington Street | Cape Town
P.O. Box 4637 | Cape Town | 8001
www.sahra.org.za

Enquiries: Natasha Higgitt
Tel: 021 462 4502
Email: nhiggitt@sahra.org.za
CaseID: 12077

Date: Thursday January 18, 2018
Page No: 1

Interim Comment

In terms of Section 38(3), 38(8) of the National Heritage Resources Act (Act 25 of 1999)

Attention: Sivest - Gauteng

PO BOX 2921
Rivonia
2128

Proposed Construction of the Graskoppies On-site Eskom Substation, Linking Substation and Associated 132kV Power Line near Loeriesfontein, Northern Cape Province

SiVEST Environmental has been appointed by SA Mainstream Renewable Power Developments (Pty) Ltd to conduct an Environmental Authorisation (EA) Application process for the proposed Graskoppies On-site Eskom Substation, Linking Substation and associated 132kV Power Line, near Loeriesfontein, Northern Cape Province. A draft Basic Assessment Report (dBAR) has submitted in terms of the National Environmental Management Act, 1998 (NEMA), and the NEMA 2017 Environmental Impact Assessment (EIA) Regulations. The proposed development will include the construction of a 2 ha on-site substation (two locations are being considered), a 5 ha linking substation (two locations are being considered) and a 132kV powerline between 54.5 and 48.1 km in length (4 route options are being considered). The powerline will have a servitude of 31 m.

PGS Heritage (Pty) Ltd was appointed to conduct the heritage component of the BAR.

Fourie, W, Angel, J and Hutten, M. 2017. Graskoppies Wind Energy Facility (WEF) – 132kV Grid connection and substation: Heritage Impact Assessment.

No heritage resources were identified within the development footprints.

Recommendations provided in the report include the following:

- A walk-down of the final layout to determine if any significant sites will be affected;
- Any heritage features of significance identified during this walk down will require formal mitigation or where possible a slight change in design could accommodate such resources;
- Monitor findspot areas if construction is going to take place through them;
- A management plan for the heritage resources needs to be implemented during construction and



an agency of the
Department of Arts and Culture

T: +27 21 462 4502 | F: +27 21 462 4509 | E: info@sahra.org.za
South African Heritage Resources Agency | 111 Harrington Street | Cape Town
P.O. Box 4637 | Cape Town | 8001
www.sahra.org.za

operations; and

- Possible surface collections for sites with a medium to high significance as well as conducting a watching brief by heritage practitioner are to be undertaken during the construction phase.

Butler, E. 2016. Palaeontological Desktop Impact Assessment for the Proposed Development of four Leeuwberg Wind Farms and Basic Assessments for the Associated Grid Connection near Loeriesfontein, Northern Cape Province.

It was noted that no separate assessment has been done for this application; it is rather part of a larger development encompassing four farms in total. Different sensitivities and thus different outcomes may apply for each of these farms.

The farm is underlain by unfossiliferous Karoo dolerite as well as sediments of the Prince Albert Formation (Ecca Group). The excavations and site clearance will involve substantial excavations into the superficial sediment cover as well as locally into the underlying bedrock. These excavations will modify the existing topography and may disturb damage, destroy or permanently seal-in fossils at or below the ground surface that are then no longer available for scientific research. According to the geology of the development site there is a possibility of finding fossils in the Ecca Group but the palaeontological sensitivity is low.

Recommendations provided in the report include the following:

- Recommended mitigation of the inevitable damage and destruction of fossil within the proposed development area would involve the surveying, recording, description and collecting of fossils within the development footprint by a professional palaeontologist. This work should take place after initial vegetation clearance has taken place, but before the ground is leveled for construction;
- Impacts on fossil heritage are generally irreversible. Well-documented records and further palaeontological studies of any fossils exposed during construction would represent a positive impact from a scientific perspective. The possibility of a negative impact on the palaeontological heritage of the area can be reduced by the implementation of adequate damage mitigation procedures. If damage mitigation is properly undertaken the benefit scale for the project will lie within the beneficial category;
- Should fossil remains be discovered during any phase of construction, either on the surface or exposed by fresh excavations, the ECO responsible for these developments should be alerted immediately. Such discoveries ought to be protected (preferably in situ) and the ECO should alert SAHRA so that appropriate mitigation (e.g. recording, sampling or collection) can be taken by a professional paleontologist. The specialist involved would require a collection permit from SAHRA. Fossil material must be curated in an approved collection (e.g. museum or university collection) and all

Our Ref:



an agency of the
Department of Arts and Culture

T: +27 21 462 4502 | F: +27 21 462 4509 | E: info@sahra.org.za
South African Heritage Resources Agency | 111 Harrington Street | Cape Town
P.O. Box 4637 | Cape Town | 8001
www.sahra.org.za

Enquiries: Natasha Higgitt
Tel: 021 462 4502
Email: nhiggitt@sahra.org.za
CaseID: 12077

Date: Thursday January 18, 2018
Page No: 3

fieldwork and reports should meet the minimum standards for palaeontological impact studies developed by SAHRA.

The submitted Environmental Management Programme (EMPr) notes the following additional mitigation measures with regards to heritage resources:

- Any finds must be reported to the nearest National Monuments office to comply with the National Heritage Resources Act (Act No 25 of 1999) and to DEA;
- Any finds must be reported to the nearest National Monuments office to comply with the National Heritage Resources Act (Act No 25 of 1999) and to DEA. Local museums as well as the South African Heritage Resource Agency (SAHRA) should be informed if any artefacts are uncovered in the affected area;
- The contractor must ensure that his workforce is aware of the necessity of reporting any possible historical or archaeological finds to the ECO so that appropriate action can be taken;
- Any discovered artefacts shall not be removed under any circumstances. Any destruction of a site can only be allowed once a permit is obtained and the site has been mapped and noted. Permits shall be obtained from the South African Heritage Resources Association (SAHRA) should the proposed site affect any world heritage sites or if any heritage sites are to be destroyed or altered;
- Should any archaeological sites / graves be uncovered during construction, their existence shall be reported to the Project Company and MC immediately.

Interim Comment

The SAHRA Archaeology, Palaeontology and Meteorites (APM) Unit disagrees with the low sensitivity given to the Prince Albert Formation as it is deemed to be of high palaeontological sensitivity according to the SAHRIS Fossil Heritage Layer Browser (<http://www.sahra.org.za/sahris/fossil-layers/prince-albert-formation>). Therefore, and in line with recommendations that include that surveying be done by a professional palaeontologist (p.31, Table 1 of the report), the APM Unit endorses such recommendation and requires a professional palaeontologist to survey the proposed development footprint. The surveying report must be submitted to SAHRA before the commencement of any development-related activities. It must be noted that the palaeontological description of the Prince Albert Formation was rather sparse and does not include references.

Further comments will be issued upon receipt of the above.

Should you have any further queries, please contact the designated official using the case number quoted above in the case header.

Our Ref:



an agency of the
Department of Arts and Culture

T: +27 21 462 4502 | F: +27 21 462 4509 | E: info@sahra.org.za
South African Heritage Resources Agency | 111 Harrington Street | Cape Town
P.O. Box 4637 | Cape Town | 8001
www.sahra.org.za

Enquiries: Natasha Higgitt
Tel: 021 462 4502
Email: nhiggitt@sahra.org.za
CaseID: 12077

Date: Thursday January 18, 2018
Page No: 4

Yours faithfully

Natasha Higgitt
Heritage Officer
South African Heritage Resources Agency

Phillip Hine
Acting Manager: Archaeology, Palaeontology and Meteorites Unit
South African Heritage Resources Agency

ADMIN:

Direct URL to case: <http://www.sahra.org.za/node/487611>
(DEA, Ref:)

Terms & Conditions:

1. This approval does not exonerate the applicant from obtaining local authority approval or any other necessary approval for proposed work.
2. If any heritage resources, including graves or human remains, are encountered they must be reported to SAHRA immediately.
3. SAHRA reserves the right to request additional information as required.



environmental affairs

Department:
Environmental Affairs
REPUBLIC OF SOUTH AFRICA

Private Bag X 447 · PRETORIA · 0001 · Environment House · 473 Steve Biko Road, Arcadia, · PRETORIA
Tel (+ 27 12) 399 9372

DEA Reference: N/A

Enquiries: Ms Portia Makitla

Telephone: (012) 399 9411 **E-mail:** pmakitla@environment.gov.za

Shaun Taylor
SiVEST Environmental
PO Box 2921
RIVONIA
2128

Telephone Number: 011 798 0600
Email Address: shaunt@sivest.co.za

PER E-MAIL

Dear Sir/Madam

COMMENTS ON THE DRAFT BASIC ASSESSMENT REPORT FOR THE PROPOSED CONSTRUCTION OF THE GRASKOPPIES ON-SITE ESKOM SUBSTATION, LINKING SUBSTATION AND ASSOCIATED 132KV POWER LINE NEAR LOERIESFONTEIN, NORTHERN CAPE PROVINCE

The draft Basic Assessment Report (BAR) dated December 2017 and received by this Department on 15 January 2018 refers.

This letter serves to inform you that the following information must be included in the final BAR

After the evaluation of the DBAR and specialist reports submitted for the proposed development, it is recommended that the following be considered during the Final Basic Assessment Report (FBAR):

- The Environmental Management Programme (EMPr) to be submitted as part of the final BAR must clearly indicate the biodiversity impacts that might occur as a result of the proposed project and the proposed mitigation measures thereof. The EMPr must not contain any ambiguity. Where applicable, statements containing the word "should" are to be amended to "must";
- You are further advised to consider or make reference to any Provincial Biodiversity Conservation Plan or guideline in your report and to obtain comments from relevant conservation authorities.

Also ensure that the Final BAR includes at least one A3 regional map of the area, ecological sensitivity map and the locality map included in the final BAR illustrate the different alternatives. The maps must be of acceptable quality and as a minimum, have the following attributes:

- Maps are relatable to one another;
- Cardinal points;
- Co-ordinates;
- Legible legends;
- Indicate alternatives;
- Latest land cover;
- Vegetation types of the study area.

You are requested to submit one (1) unprotected electronic copy (CD/DVD) of the complete final report which include the locality and ecological sensitivity map to this Directorate with attention to **Mr Stanley Tshitwamulomoni**.

Yours faithfully



Ms Wilma Lutsch

Director: Biodiversity Conservation

Department of Environmental Affairs

Letter Signed by: Mr Stanley Tshitwamulomoni

Designation: Control Biodiversity Officer Grade B

Date: 5/02/18

sivest_PPP

From: BBotes <bvotes@ncpg.gov.za>
Sent: 23 February 2018 10:39 AM
To: BFisher
Cc: sivest_PPP; TMakaudi
Subject: Fwd: FW: Proposed Mainstream Substations and Power Lines for the Wind Farms near Loeriesfontein: DBARs Comment Period Ended

Importance: High

Dear Mr Fisher,

For your urgent attention please

Regards

Beanca Botes for
MR L ABRAHAMS
ACTING HEAD OF DEPARTMENT

Department of Environment and
Nature Conservation
Private Bag X6102
KIMBERLEY
8300

Tel: 053-8077306
Fax: 053-8077367/0866 256 470
Cellphone: 082 3316 039

>>> sivest_PPP <sivest_ppp@sivest.co.za> 2/23/2018 10:12 AM >>>
FYA

From: sivest_PPP
Sent: 22 February 2018 04:16 PM
To: Andrea Gibb <AndreaG@sivest.co.za>; Stephan Jacobs <StephanJ@sivest.co.za>; 'rebecca.thomas@mainstreamrp.com' <rebecca.thomas@mainstreamrp.com>; 'Nicolene Venter' <nicolene@imaginativeafrica.co.za>
Cc: 'John Geeringh' <GeerinJH@eskom.co.za>; 'Heleen van den Heever' <vdheevhd@telkom.co.za>; 'Morgan Griffiths' <morgan.griffiths@wessa.co.za>; 'Obakeng Isaacs' <munman@khaima.gov.za>; 'P Josop' <commonage@khaima.gov.za>; 'Brian Fisher' <bfisher@ncpg.gov.za>; 'Henning Myburg' <henning@agrink.co.za>; 'Sam Fiff' <Francis.Rahlapane@transnet.net>; 'Amanda Bester' <WayleaCR@telkom.co.za>; 'Riaan Van Wyk' <socialdev1@hantam.gov.za>; 'Natasha Higgitt' <nhiggitt@sahra.org.za>; 'Nicole Abrahams' <AbrahamsN@nra.co.za>; 'Ted Williams' <williams@saa.ac.za>; 'Chris Coetzee' <chris@salt.ac.za>; 'Hettie Buys' <HettieB@daff.gov.za>; 'Thoko Buthelezi' <ThokoB@daff.gov.za>; 'Mmatlala Rabothata' <mrabothata@environment.gov.za>; 'Marianne Golding' <marianneg@ewt.org.za>; 'Simphiwe Masilela' <ObstacleEvaluators@atns.co.za>; 'Candice Stevens' <advocacy@birdlife.org.za>; 'Johanna Morobane' <JohannaM@atns.co.za>; 'Lizell Stroh' <strohl@caa.co.za>; 'Adriaan Tiplady' <atiplady@ska.ac.za>; 'Ramatholo Sefako' <rrs@sao.ac.za>; 'Samantha Ralston-Paton' <energy@birdlife.org.za>; 'Gert Steenkamp' <gsteenkamp@ncpg.gov.za>; 'Moses Mahunonyane' <MahunonyaneM@dws.gov.za>; 'Johan Koegelenberg' <KoegelenbergJ@sentech.co.za>; 'Lourens Leeuwner' <lourensl@ewt.org.za>; 'Stanley Tshitwamulomoni'

<StanleyT@environmental.gov.za>; 'Candice Spammer' <spammec1@telkom.co.za>; 'Seoka Lekota' <slekota@environment.gov.za>; 'Jaco Roelofse' <roelofse.j@vodamail.co.za>; 'Patrick Lenyibi' <plenyibi@ncpg.gov.za>; 'Ester Makungo' <makungoe@dws.gov.za>; 'Garth Julius' <JuliusG@nra.co.za>; 'Jannie Loubser' <janniel@namakwa-dm.gov.za>; 'ruth.cuttings@yahoo.com' <ruth.cuttings@yahoo.com>; 'kmotlhoml@ncpg.gov.za' <kmotlhoml@ncpg.gov.za>; 'lefleurd@dws.gov.za' <lefleurd@dws.gov.za>; 'BesterAD@telkom.co.za' <BesterAD@telkom.co.za>

Subject: RE: Proposed Mainstream Substations and Power Lines for the Wind Farms near Loeriesfontein: DBARs Comment Period Ended

Importance: High

******* Please note that this email was sent from a NO REPLY email address. Please do not reply to this address as it is an unmonitored email account.*******

Dear Stakeholder,

BASIC ASSESSMENTS (BAS) FOR THE PROPOSED DEVELOPMENT OF THE 132KV MAINSTREAM LINKING SUBSTATION AND FOUR (4) 132KV ON-SITE ESKOM SUBSTATIONS AND POWER LINES NEAR LOERIESFONTEIN, NORTHERN CAPE PROVINCE

- **132kV Graskoppies Substations and Power line – (DEA Ref No.: To be Announced)**
- **132kV Hartbeest Leegte Substations and Power Line – (DEA Ref No.: To be Announced)**
- **132kV Ithemba Substations and Power Line – DEA Ref No.: To be Announced)**
- **132kV IXha Boom Substations and Power Line – DEA Ref No.: To be Announced)**

Please note that the final day for comments on the Draft Basic Assessments Reports (DBARs) for the above mentioned wind farm projects was **on Monday 05 February 2018.**

This email serves as a reminder to please submit any comments if not done already.

If you do not have any comments please reply to the email and indicate so.

Should you have any comments, please feel free to contact the public participation office at the details below:

SiVEST Environmental

Hlengiwe Ntuli / Stephan Jacobs

PO BOX 2921

Rivonia

2128

Tel: 011 798 0600

Fax: 011 803 7272

Email: hlengiwen@sivest.co.za / stephanj@sivest.co.za

Kind Regards,

Hlengiwe Ntuli

Projects Secretary and PPP Administrator

SiVEST Environmental Division



SiVEST is a Level 3 BBBEE Contributor

Direct +27 11 798 0690 **Tel** +27 11 798 0600 **fax** +27 11 803 7272

Consulting Engineers - Project Managers - Environmental Consultants - Town and Regional Planners
Durban - Johannesburg - Pietermaritzburg - Richards Bay - Port Louis (Mauritius)

From: sivest_PPP
Sent: 31 January 2018 08:36 AM
To: Andrea Gibb <AndreaG@sivest.co.za>; Stephan Jacobs <StephanJ@sivest.co.za>; 'rebecca.thomas@mainstreamrp.com' <rebecca.thomas@mainstreamrp.com>; 'Nicolene Venter' <nicolene@imaginativeafrica.co.za>
Cc: 'John Geering' <GeerinJH@eskom.co.za>; 'Heleen van den Heever' <vdheevhd@telkom.co.za>; 'Morgan Griffiths' <morgan.griffiths@wessa.co.za>; 'Obakeng Isaacs' <munman@khaima.gov.za>; 'P Josop' <commonage@khaima.gov.za>; 'Brian Fisher' <bfisher@ncpg.gov.za>; 'Henning Myburg' <henning@agrink.co.za>; 'Sam Fiff' <Francis.Rahlapane@transnet.net>; 'Amanda Bester' <WayleaCR@telkom.co.za>; 'Riaan Van Wyk' <socialdev1@hantam.gov.za>; 'Natasha Higgitt' <nhiggitt@sahra.org.za>; 'Nicole Abrahams' <AbrahamsN@nra.co.za>; 'Ted Williams' <williams@saa.ac.za>; 'Chris Coetzee' <chris@salt.ac.za>; 'Hettie Buys' <HettieB@daff.gov.za>; 'Thoko Buthelezi' <ThokoB@daff.gov.za>; 'Mmatlala Rabothata' <mrabothata@environment.gov.za>; 'Marianne Golding' <marianneg@ewt.org.za>; 'Simphiwe Masilela' <ObstacleEvaluators@atns.co.za>; 'Candice Stevens' <advocacy@birdlife.org.za>; 'Johanna Morobane' <JohannaM@atns.co.za>; 'Lizell Stroh' <strohl@caa.co.za>; 'Adriaan Tiplady' <atiplady@ska.ac.za>; 'Ramatholo Sefako' <rrs@saa.ac.za>; 'Samantha Ralston-Paton' <energy@birdlife.org.za>; 'Gert Steenkamp' <gsteenkamp@ncpg.gov.za>; 'Moses Mahunonyane' <MahunonyaneM@dws.gov.za>; 'Johan Koegelenberg' <KoegelenbergJ@sentech.co.za>; 'Lourens Leeuwener' <lourensl@ewt.org.za>; 'Stanley Tshitwamulomoni' <StanleyT@environmental.gov.za>; 'Candice Spammer' <spammec1@telkom.co.za>; 'Seoka Lekota' <slekota@environment.gov.za>; 'Jaco Roelofse' <roelofse.j@vodamail.co.za>; 'Patrick Lenyibi' <plenyibi@ncpg.gov.za>; 'Ester Makungo' <makungoe@dws.gov.za>; 'Garth Julius' <JuliusG@nra.co.za>; 'Jannie Loubser' <janniel@namakwa-dm.gov.za>; 'ruth.cuttings@yahoo.com' <ruth.cuttings@yahoo.com>; 'kmotlhomini@ncpg.gov.za' <kmotlhomini@ncpg.gov.za>; 'lefleurd@dws.gov.za' <lefleurd@dws.gov.za>; 'BesterAD@telkom.co.za' <BesterAD@telkom.co.za>
Subject: RE: Proposed Mainstream Substations and Power Lines for the Wind Farms near Loeriesfontein: DBARs Comment Period Ending
Importance: High

******* Please note that this email was sent from a NO REPLY email address. Please do not reply to this address as it is an unmonitored email account.*******

Dear Stakeholder,

BASIC ASSESSMENTS (BAS) FOR THE PROPOSED DEVELOPMENT OF THE 132KV MAINSTREAM LINKING SUBSTATION AND FOUR (4) 132KV ON-SITE ESKOM SUBSTATIONS AND POWER LINES NEAR LOERIESFONTEIN, NORTHERN CAPE PROVINCE

- 132kV Graskoppies Substations and Power line – (DEA Ref No.: To be Announced)
- 132kV Hartbeest Leegte Substations and Power Line – (DEA Ref No.: To be Announced)
- 132kV Ithemba Substations and Power Line – DEA Ref No.: To be Announced)
- 132kV IXha Boom Substations and Power Line – DEA Ref No.: To be Announced)

Please note that the final day for comments on the Draft Basic Assessments Reports (DBARs) for the above mentioned wind farm projects is **on Monday 05 February 2018**.

This email serves as a reminder to please submit any comments by the close of business on the **Monday 05 February 2018 (COB)**

Should you have any comments, please feel free to contact the public participation office at the details below:

SiVEST Environmental

Hlengiwe Ntuli / Stephan Jacobs

PO BOX 2921

Rivonia

2128

Tel: 011 798 0600

Fax: 011 803 7272

Email: hlengiwen@sivest.co.za / stephanj@sivest.co.za

<< File: 13622 DBAR Notification Letter IAPs (Afr).pdf >> << File: 13622 DBAR Notification Letter IAPs (Eng).pdf >>

Kind Regards

Andrea Gibb

Senior Manager

SiVEST Environmental Division

SiVEST is a Level 3 BBBEE Contributor

Direct +27 11 798 0638 Tel +27 11 798 0600 fax +27 11 803 7272

email andrea@sivest.co.za website www.sivest.co.za

Consulting Engineers - Project Managers - Environmental Consultants - Town and Regional Planners

Durban - Johannesburg - Pietermaritzburg - Richards Bay - Ladysmith - Cape Town - Harare (Zimbabwe)

From: sivist_PPP

Sent: 14 December 2017 04:54 PM

To: Andrea Gibb <AndreaG@sivest.co.za>; Stephan Jacobs <StephanJ@sivest.co.za>;

'rebecca.thomas@mainstreamrp.com' <rebecca.thomas@mainstreamrp.com>; 'Nicolene Venter'

<nicolene@imaginativeafrica.co.za>

Cc: 'John Geeringh' <GeerinJH@eskom.co.za>; 'Heleen van den Heever' <vdheevhd@telkom.co.za>; 'Morgan

Griffiths' <morgan.griffiths@wessa.co.za>; 'Obakeng Isaacs' <munman@khaima.gov.za>; 'P Josop'

<commonage@khaima.gov.za>; 'Brian Fisher' <bfisher@ncpg.gov.za>; 'Henning Myburg' <henning@agrink.co.za>;

'Sam Fiff' <Francis.Rahlapane@transnet.net>; 'Amanda Bester' <WayleaCR@telkom.co.za>; 'Riaan Van Wyk'

<socialdev1@hantam.gov.za>; 'Natasha Higgitt' <nhiggitt@sahra.org.za>; 'Nicole Abrahams'

<AbrahamsN@nra.co.za>; 'Ted Williams' <williams@saa.ac.za>; 'Chris Coetzee' <chris@salt.ac.za>; 'Hettie Buys'

<HettieB@daff.gov.za>; 'Thoko Buthelezi' <ThokoB@daff.gov.za>; 'Mmatlala Rabothata'

<mrabothata@environment.gov.za>; 'Marianne Golding' <marianneg@ewt.org.za>; 'Simpfiwe Masilela'

<ObstacleEvaluators@atns.co.za>; 'Candice Stevens' <advocacy@birdlife.org.za>; 'Johanna Morobane'

<JohannaM@atns.co.za>; 'Lizell Stroh' <strohl@caa.co.za>; 'Adriaan Tiplady' <atiplady@ska.ac.za>; 'Ramatholo

Sefako' <rrs@saa.ac.za>; 'Samantha Ralston-Paton' <energy@birdlife.org.za>; 'Gert Steenkamp'

<gsteenkamp@ncpg.gov.za>; 'Moses Mahunonyane' <MahunonyaneM@dws.gov.za>; 'Johan Koegelenberg'

<KoegelenbergJ@sentech.co.za>; 'Lourens Leeuwner' <lourensl@ewt.org.za>; 'Stanley Tshitwamulomoni'

<StanleyT@environmental.gov.za>; 'Candice Spammer' <spammec1@telkom.co.za>; 'Seoka Lekota'

<slekota@environment.gov.za>; 'Jaco Roelofse' <roelofse.j@vodamail.co.za>; 'Patrick Lenyibi'

<plenyibi@ncpg.gov.za>; 'Ester Makungo' <makungoe@dws.gov.za>; 'Garth Julius' <JuliusG@nra.co.za>; 'Jannie

Loubser' <janniel@namakwa-dm.gov.za>; 'ruth.cuttings@yahoo.com' <ruth.cuttings@yahoo.com>;

'kmotlhomini@ncpg.gov.za' <kmotlhomini@ncpg.gov.za>; 'lefleurd@dws.gov.za' <lefleurd@dws.gov.za>;

'BesterAD@telkom.co.za' <BesterAD@telkom.co.za>

Subject: Proposed Mainstream Substations and Power Lines for the Wind Farms near Loeriesfontein: DBARs Available for Review

******* Please note that this email was sent from a NO REPLY email address. Please do not reply to this address as it is an unmonitored email account.*******

BASIC ASSESSMENTS (BAS) FOR THE PROPOSED DEVELOPMENT OF THE 132KV MAINSTREAM LINKING SUBSTATION AND FOUR (4) 132KV ON-SITE ESKOM SUBSTATIONS AND POWER LINES NEAR LOERIESFONTEIN, NORTHERN CAPE PROVINCE

- **132kV Graskoppies Substations and Power line – (DEA Ref No.: To be Announced)**
- **132kV Hartbeest Leegte Substations and Power Line – (DEA Ref No.: To be Announced)**
- **132kV Ithemba Substations and Power Line – DEA Ref No.: To be Announced)**
- **132kV !Xha Boom Substations and Power Line – DEA Ref No.: To be Announced)**

SiVEST is in the process of undertaking the Basic Assessments (BAs) for the proposed development of the above-mentioned Substations and Power Lines near Loeriesfontein in the Northern Cape Province.

We would like to take this opportunity to inform you that, in accordance with the National Environmental Management Act (NEMA) (as amended), the Draft Basic Assessment Reports (DBARs) will be made available for public comment and review as from **Thursday 14 December 2017 to Monday 05 February 2018** (before end of business day).

The DBARs as well as the accompanying appendices are available online (<http://www.sivest.co.za/> click on 'Downloads' and navigate to '13622 Mainstream Substations and Power Lines') and an electronic copy (on CD) has been posted to you. We kindly request that you submit your comments to Public Participation Office at the below details, on or before **Monday 05 February 2018** (before end of business day). SiVEST will forward any comments received after the public comment and review period directly to the relevant case officer at the Department of Environmental Affairs (DEA).

Should you have any questions or queries please do not hesitate to contact us at:

Stephan Jacobs / Hlengiwe Ntuli

PO BOX 2921, Rivonia, 2128

Tel – (011) 798 0600

Fax – (011) 803 7272

Email – stephanj@sivest.co.za /
hlengiwen@sivest.co.za

Kind Regards

Andrea Gibb

Senior Manager

SiVEST Environmental Division

SiVEST is a Level 3 BBBEE Contributor

Direct +27 11 798 0638 **Tel** +27 11 798 0600 **fax** +27 11 803 7272

email andreaq@sivest.co.za **website** www.sivest.co.za

Consulting Engineers - Project Managers - Environmental Consultants - Town and Regional Planners
Durban - Johannesburg - Pietermaritzburg - Richards Bay - Ladysmith - Cape Town - Harare (Zimbabwe)

Disclaimer

The information contained in this communication from the sender is confidential. It is intended solely for use by the recipient and others authorized to receive it. If you are not the recipient, you are hereby notified that any disclosure, copying, distribution or taking action in relation of the contents of this information is strictly prohibited and may be unlawful.

This email has been scanned for viruses and malware, and automatically archived by Mimecast SA (Pty) Ltd, an innovator in Software as a Service (SaaS) for business. Mimecast Unified Email Management ??? (UEM) offers email continuity, security, archiving and compliance with all current legislation. To find out more, [contact Mimecast](#).

This email and any files transmitted with it are confidential and intended solely for the use of the individual or entity to whom they are addressed. If you have received this email in error please notify the system manager. Please note that any views or opinions presented in this email are solely those of the author and do not necessarily represent those of the company. Finally, the recipient should check this email and any attachments for the presence of viruses. The company accepts no liability for any damage caused by any virus transmitted by this email.

Stephan Jacobs

From: Natasha Higgitt <nhiggitt@sahra.org.za>
Sent: Tuesday, February 27, 2018 11:59 AM
To: Stephan Jacobs
Subject: Re: Proposed Mainstream Substations and Power Lines for the Wind Farms near Loeriesfontein: Response Letters to SAHRA Interim Comments and Updated HIA & Desktop PIA Reports uploaded to Case Applications

Thank you for your email. I am currently out of the office. I will attend to your emails when I return on the 28 February 2018. For urgent issues please contact Mr Phillip Hine (phine@sahra.org.za).

Kind Regards,

Natasha Higgitt
Heritage Officer: Archaeology, Palaeontology and Meteorites Unit

South African Heritage Resources Agency
- A nation united through heritage -

T: +27 21 462 4502 | C: +27 82 507 0378 | F: +27 21 462 4509
E: nhiggitt@sahra.org.za | 111 Harrington Street | Cape Town

www.sahra.org.za

This electronic communication and its content(s) are subject to a disclaimer which can be accessed here:
<http://mail.sahra.org.za/disclaimer.html>



Appendix 7D3
Correspondence
To IAPs

Stephan Jacobs

From: sivest_PPP
Sent: Wednesday, October 25, 2017 2:15 PM
To: Andrea Gibb; 'Nicolene Venter'
Cc: Shaun Taylor; Stephan Jacobs
Subject: PROPOSED 4 MAINSTREAM WIND FARMS AND ASSOCIATED GRID CONNECTION /
Attachments: Leeuwborg POD InviteLet (Eng) FINAL.pdf; Leeuwborg POD RegForm (Eng) FINAL.PDF;
Leeuwborg POD InviteLet (Afr) FINAL.pdf; Leeuwborg POD RegForm (Afr) FINAL.PDF

Please note that this email was sent from a NO REPLY email address. Please do not reply to this email address as it is an unmonitored email account **

*** Neem asseblief kennis dat hierdie epos vanaf 'n GEEN ANTWOORD epos adres gestuur is. Moet asseblief nie "reply" op hierdie epos nie aangesien dit 'n onbemande e-pos adres is *****

Dear Interested and/or Affected Party,

ENVIRONMENTAL IMPACT ASSESSMENTS (EIAs) AND ENVIRONMENTAL MANAGEMENT PROGRAMMES (EMPrs) FOR THE FOUR PROPOSED MAINSTREAM WIND FARMS and BASIC ASSESSMENTS (BAs) FOR THE ASSOCIATED GRID CONNECTION NEAR LOERIESFONTEIN, NORTHERN CAPE PROVINCE

DEA Ref. Hartebeest Leegte Wind Farm 14/12/16/3/3/2/1015
Ithemba Wind Farm 14/12/16/3/3/2/1016
Graskoppies Wind Farm 14/12/16/3/3/2/1017
!Xha Boom Wind Farm 14/12/16/3/3/2/1018
DEA Ref for Grid Connection: To be issued

Please find attached your invitation to attend the Public Open Day (poster display) that will be held for the above-mentioned proposed projects on:

DATE	TIME	VENUE
Wednesday, 01 November 2017	Starts at 11h30 until 13h00	Loeriesfontein Recreation Hall, Rugby Street, Loeriesfontein

We kindly request that you complete the attached Registration Form and return it to the Public Participation team on or before Friday, 27 October 2017.

Kind regards

Beste Belanghebbende en/of Geaffekteerde Pary,

OMGEWINGSIMPAAKEVALUERINGS (OIE's) EN OMGEWINGSBESTUURSPROGRAMME (OBPr'e) VIR DIE BEOOGDE VIER MAINSTREAM WINDPLASE en BASIESE EVALUERINGS (BE's) VIR DIE GEPAARDGAANDE ROOSTERKONNEKSIE NABY LOERIESFONTEIN, NOORD-KAAPPROVINSIE

DO Verw. Hartebeest Leegte Windplaas 14/12/16/3/3/2/1015

Ithemba Windplaas 14/12/16/3/3/2/1016

Graskoppies Windplaas 14/12/16/3/3/2/1017

!Xha Boom Windplaas 14/12/16/3/3/2/1018

DO Verw vir Roosterkonneksie: Moet aangekondig word

Vind asseblief aangeheg u uitnodiging om die Publieke-Opedag wat vir die bogenoemde voorgestelde projekte gehou word op:

DATUM	TYD	PLEK
Woensdag, 01 November 2017	Begin om 11h30 tot 13h00	Loeriesfontein Sportsaal, Rugbystraat, Loeriesfontein

Ons versoek u vriendelik om die ingeslote Registrasievorm te voltooi en aan die Openbare Deelname span te stuur voor of op Vrydag, 27 Oktober 2017.

Vriendelike groete,

Andrea Gibb (*B.Sc. Landscape Architecture; B.Sc(Hons) Environmental Management*)

Environmental Practitioner and Visual Specialist

SiVEST Environmental Division



SiVEST is a Level 3 BBBEE Contributor

Direct +27 11 798 0677 **Tel** +27 11 798 0600 **fax** +27 11 803 7272 **cell** +27 72 737 2114

email stephaj@sivest.co.za **website** www.sivest.co.za



MEMBER ORGANISATION 2017



Consulting Engineers - Project Managers - Environmental Consultants - Town and Regional Planners

Durban - Johannesburg - Pietermaritzburg - Richards Bay - Port Louis (Mauritius)

Stephan Jacobs

From: sivest_PPP
Sent: Thursday, December 14, 2017 4:49 PM
Cc: Andrea Gibb; Stephan Jacobs; 'rebecca.thomas@mainstreamrp.com'; 'Nicolene Venter'
Subject: 13622 Proposed Substations and Power Lines for the Wind Farms near Loeriesfontein: DBAR Comment Period Starting

******* Please note that this email was sent from a NO REPLY email address. Please do not reply to this address as it is an unmonitored email account.*******

Dear Interested and/or Affected Party,

BASIC ASSESSMENTS (BAS) FOR THE PROPOSED DEVELOPMENT OF THE 132kV MAINSTREAM LINKING SUBSTATION AND FOUR (4) 132kV ON-SITE ESKOM SUBSTATIONS AND POWER LINES NEAR LOERIESFONTEIN, NORTHERN CAPE PROVINCE

- **132kV Graskoppies Substations and Power line**
– (DEA Ref No.: To be Announced)
- **132kV Hartebeest Leegte Substations and Power Line**
– (DEA Ref No.: To be Announced)
- **132kV Ithemba Substations and Power Line**
– (DEA Ref No.: To be Announced)
- **132kV !Xha Boom Substations and Power Line**
– (DEA Ref No.: To be Announced)

• AVAILABILITY OF THE DRAFT BASIC ASSESSMENT REPORTS FOR PUBLIC REVIEW

SiVEST is in the process of undertaking the Basic Assessments (BAs) for the proposed development of the above mentioned Substations and Power Lines near Loeriesfontein in the Northern Cape Province.

We would like to inform you that, in accordance with the National Environmental Management Act (NEMA) (as amended), the Draft Basic Assessment Reports (DBARs) for the above-mentioned projects will be made available for public review and comment as from **Thursday 14 December 2017** to **Monday 05 February 2018** (before end of business day). Hard copies of the DBARs are available at the following venue:

VENUE	STREET ADDRESS	HOURS	CONTACT NO
Loeriesfontein Library	Main Street, Loeriesfontein	Mondays – Fridays 14h00 – 17h00	027 662 8607

The reports as well as the accompanying appendices are also available on SiVEST's website: <http://www.sivest.co.za/>, click on downloads, then browse to the folder '13622 Mainstream Substations and Power Lines'.

Attached are English and Afrikaans letters notifying you of the availability of the reports, including Comment Forms.



13622 DBAR



13622 DBAR



13622_Mainstream

Notification Lett... Notification Lett... Leeuwberg Gri...

We kindly request that you submit your comments to Public Participation Office at the below details, on or before **Monday 05 February 2018** (before end of business day). SiVEST will forward any comments received after the public comment and review period directly to the relevant case officer at the Department of Environmental Affairs (DEA).

Should you have any questions or queries please do not hesitate to contact us at:

Stephan Jacobs / Hlengiwe Ntuli

PO BOX 2921, Rivonia, 2128

Tel – (011) 798 0600

Fax – (011) 803 7272

Email – stephanj@sivest.co.za / hlengiwen@sivest.co.za

Kind Regards

.....
ONDERWERP: 13622 Voorgestelde Substasies en Kraglyne vir doe Windplase naby Loeriesfontein: KBEV Kommentaar
Periode Begin

Geagte Belangstellende en/of Geaffekteerde Party,

**BASIESE EVALUERINGS (BE's) VIR DIE BEOOGDE ONTWIKKELING VAN DIE 132KV MAINSTREAM SKAKEL
SUBSTASIE EN VIER (4) 132KV OP PERSEEL ESKOM SUBSTASIES EN KRAGLYNE NABY LOERIESFONTEIN,
NOORD-KAAP PROVINSIE**

- **132kV Graskoppies Substasies en Kraglyn**
– (DEA Verwysings No.: Moet nog aangekondig word)
- **132kV Hartbeest Leegte Substasies en Kraglyn**
– (DEA Verwysings No.: Moet nog aangekondig word)
- **132kV Ithemba Substasies en Kraglyn**
– DEA Verwysings No.: Moet nog aangekondig word)
- **132kV !Xha Boom Substasies en Kraglyn**
– DEA Verwysings No.: Moet nog aangekondig word)

• **BESKIKBAARHEID VAN DIE KONSEP BASIESE EVALUERINGSVERSLAE VIR OPENBARE OORSIG**

SiVEST is in die proses om die Basiese Evalueringe (BE's) vir die voorgestelde ontwikkeling van die bogenoemde Substasies en Kraglyne naby Loeriesfontein in die Noord-Kaap Provinsie te onderneem.

Ons lig u graag hiermee in dat die Konsep Basiese Evalueringe (KBEV's) vir die bogenoemde projekte, ooreenkomstig die Nasionale Wet op Omgewingsbestuur (NEMA) (soos gewysig), vanaf **Donderdag 14 Desember 2017** tot **Maandag 05 Februarie 2018** (voor die einde van die werksdag) beskikbaar gemaak sal wees vir openbare oorsig en kommentaar. Gedrukte kopieë van die KBEV's is beskikbaar by die plek wat hieronder genoem word:

PLEK	STRAATADRES	TYE	KONTAKNOMMER
Loeriesfontein Biblioteek	Mainstraat, Loeriesfontein	Maandae – Vrydae 14h00 – 17h00	027 662 8607

Die verslae sowel as die meegaande aanhangsels is ook beskikbaar op SiVEST se webwerf: <http://www.sivest.co.za>. Klik op 'Downloads' en soek dan vir die gids '13622 Mainstream Substations and Power Lines'.

Aangeheg is Engelse en Afrikaanse briewe wat u inlig oor die beskikbaarheid van die verslae, insluitende Kommentaarvorms.

Ons versoek u vriendelik om u kommentaar by die publieke deelnemende kantoor in te dien by die onderstaande besonderhede, voor of op **Maandag 05 Februarie 2018** (voor die einde van die werksdag). SiVEST sal enige kommentaar wat na die openbare kommentaar en oorsigperiode ontvang word, direk aan die betrokke saakbeampte by die Departement van Omgewingsake (DEA) stuur.

Indien u enige vrae of navrae het, moet asseblief nie huiwer om ons te kontak by:

Stephan Jacobs / Hlengiwe Ntuli

Posbus 2921, Rivonia, 2128

Tel – (011) 798 0600

Faks – (011) 803 7272

E-pos – stephanj@sivest.co.za / hlengiwen@sivest.co.za

Vriendelike groete,

Kind Regards

Andrea Gibb

Senior Manager

SiVEST Environmental Division



SiVEST is a Level 3 BBBEE Contributor

Direct +27 11 798 0638 **Tel** +27 11 798 0600 **fax** +27 11 803 7272

email andrea@sivest.co.za **website** www.sivest.co.za



Consulting Engineers - Project Managers - Environmental Consultants - Town and Regional Planners
Durban - Johannesburg - Pietermaritzburg - Richards Bay - Ladysmith - Cape Town - Harare (Zimbabwe)

Stephan Jacobs

From: Stephan Jacobs
Sent: Friday, December 15, 2017 12:01 PM
To: 'Irene Bezuidenhout'; Hlengiwe Ntuli
Cc: Andrea Gibb; rebecca.thomas@mainstreamrp.com; Michael Barnes
Subject: RE: 13622 Proposed Substations and Power Lines for the Wind Farms near Loeriesfontein: DBAR Comment Period Starting
Attachments: 13622_GrasskopiesGridCon_23May2017.kml; 13622_HartebeestLeegteGridCon_23May2017.kml; 13622_IthembaGridCon_23May2017.kml; 13622_XhaBoomGridCon_23May2017.kml
Importance: High

Hi Irene,

As requested, please find attached KMLs for the proposed substation and power line projects Mainstream are proposing near Loeriesfontein. These substations and power lines will connect the proposed Graskoppies, Hartebeest Leegte, Ithemba and IXha Boom Wind Farms to the national grid at Helios MTS.

Please note that corridor Option 4 is Mainstream's preferred power line corridor option.

Kind Regards,

Stephan Jacobs (B.Sc.(Hons) *Environmental Management and Analysis*)

Environmental Consultant

SiVEST Environmental Division



SiVEST is a Level 3 BBBEE Contributor

Direct +27 11 798 0677 **Tel** +27 11 798 0600 **fax** +27 11 803 7272 **cell** +27 72 737 2114
email stephanj@sivest.co.za **website** www.sivest.co.za



Consulting Engineers - Project Managers - Environmental Consultants - Town and Regional Planners - Quality Management Consultants
Durban - Johannesburg - Pretoria - Pietermaritzburg - Richards Bay - Port Louis (Mauritius)

SiVEST offices will be closing for the Christmas and New Year holiday season break from 16h00 on Wednesday, 20th December 2017 and will re-open at 08h00 on Monday, 8th January 2018

From: Irene Bezuidenhout [mailto:iBezuidenhout@biothermenergy.com]
Sent: Friday, December 15, 2017 11:18 AM
To: Stephan Jacobs; Hlengiwe Ntuli
Cc: Andrea Gibb; rebecca.thomas@mainstreamrp.com; Michael Barnes
Subject: RE: 13622 Proposed Substations and Power Lines for the Wind Farms near Loeriesfontein: DBAR Comment Period Starting

Hi Stephan,

Thank you for the notification. Please can you provide me with a kmz file for the proposed powerline route options in order for us to provide comment if necessary. BioTherm Energy has an EA for the proposed 70MW Loeriesfontein PV

facility and a separate EA for a 132kV powerline to Helios substation, I need to see if the proposed routes will impact on our authorised site and layout and/or authorised route alignment to Helios substation. We understand that the IPPs infrastructure have to coexist and we need to come up with an optimal solution which will suit all parties should there be a potential impact to our authorised infrastructure.

Kind regards

Irene Bezuidenhout | Environmental Manager

BioTherm Energy (Pty) Ltd

Building 1, Leslie Ave East Design Quarter District, Fourways

P: +27 (0) 11 367 4600 | F: +27 (0) 11 367 4601 | M:+27 (0) 76 822 3484

E: ibeuidenhout@biothermenergy.com



www.biothermenergy.com



Please note that confidential information may be contained in this message. If you are not the addressee indicated in this message you may not copy or deliver this message to anyone. In that event, you should destroy this message and kindly notify the sender by reply e-mail. Any opinions, conclusions and other information contained in this message that do not relate to the official business of BioTherm Energy Group of Companies are neither given nor endorsed by it.

From: sivest_PPP [mailto:sivest_ppp@sivest.co.za]

Sent: Thursday, 14 December, 2017 4:49 PM

Cc: Andrea Gibb <AndreaG@sivest.co.za>; Stephan Jacobs <StephanJ@sivest.co.za>;

'rebecca.thomas@mainstreamrp.com' <rebecca.thomas@mainstreamrp.com>; 'Nicolene Venter' <nicolene@imaginativeafrica.co.za>

Subject: 13622 Proposed Substations and Power Lines for the Wind Farms near Loeriesfontein: DBAR Comment Period Starting

******* Please note that this email was sent from a NO REPLY email address. Please do not reply to this address as it is an unmonitored email account.*******

Dear Interested and/or Affected Party,

BASIC ASSESSMENTS (BAS) FOR THE PROPOSED DEVELOPMENT OF THE 132kV MAINSTREAM LINKING SUBSTATION AND FOUR (4) 132kV ON-SITE ESKOM SUBSTATIONS AND POWER LINES NEAR LOERIESFONTEIN, NORTHERN CAPE PROVINCE

- **132kV Graskoppies Substations and Power line**
 - (DEA Ref No.: To be Announced)

- **132kV Hartebeest Leegte Substations and Power Line**
 - (DEA Ref No.: To be Announced)

- **132kV Ithemba Substations and Power Line**
 - (DEA Ref No.: To be Announced)

- **132kV !Xha Boom Substations and Power Line**

– (DEA Ref No.: To be Announced)

- **AVAILABILITY OF THE DRAFT BASIC ASSESSMENT REPORTS FOR PUBLIC REVIEW**

SiVEST is in the process of undertaking the Basic Assessments (BAs) for the proposed development of the above mentioned Substations and Power Lines near Loeriesfontein in the Northern Cape Province.

We would like to inform you that, in accordance with the National Environmental Management Act (NEMA) (as amended), the Draft Basic Assessment Reports (DBARs) for the above-mentioned projects will be made available for public review and comment as from **Thursday 14 December 2017** to **Monday 05 February 2018** (before end of business day). Hard copies of the DBARs are available at the following venue:

VENUE	STREET ADDRESS	HOURS	CONTACT NO
Loeriesfontein Library	Main Street, Loeriesfontein	Mondays – Fridays 14h00 – 17h00	027 662 8607

The reports as well as the accompanying appendices are also available on SiVEST's website: <http://www.sivest.co.za/>, click on downloads, then browse to the folder '13622 Mainstream Substations and Power Lines'.

Attached are English and Afrikaans letters notifying you of the availability of the reports, including Comment Forms.

We kindly request that you submit your comments to Public Participation Office at the below details, on or before **Monday 05 February 2018** (before end of business day). SiVEST will forward any comments received after the public comment and review period directly to the relevant case officer at the Department of Environmental Affairs (DEA).

Should you have any questions or queries please do not hesitate to contact us at:

Stephan Jacobs / Hlengiwe Ntuli

PO BOX 2921, Rivonia, 2128

Tel – (011) 798 0600

Fax – (011) 803 7272

Email – stephanj@sivest.co.za / hlengiwen@sivest.co.za

Kind Regards

ONDERWERP: 13622 Voorgestelde Substasies en Kraglyne vir doe Windplase naby Loeriesfontein: KBEV Kommentaar Periode Begin

Geagte Belangstellende en/of Geaffekteerde Party,

BASIESE EVALUERINGS (BE's) VIR DIE BEOOGDE ONTWIKKELING VAN DIE 132KV MAINSTREAM SKAKEL SUBSTASIE EN VIER (4) 132KV OP PERSEEL ESKOM SUBSTASIES EN KRAGLYNE NABY LOERIESFONTEIN, NOORD-KAAP PROVINSIE

- **132kV Graskoppies Substasies en Kraglyn**

– (DEA Verwysings No.: Moet nog aangekondig word)

- **132kV Hartbeest Leegte Substasies en Kraglyn**

– (DEA Verwysings No.: Moet nog aangekondig word)

- 132kV Ithemba Substasies en Kraglyn

– DEA Verwysings No.: Moet nog aangekondig word)

- 132kV !Xha Boom Substasies en Kraglyn

– DEA Verwysings No.: Moet nog aangekondig word)

- **BESKIKBAARHEID VAN DIE KONSEP BASIESE EVALUERINGSVERSLAE VIR OPENBARE OORSIG**

SiVEST is in die proses om die Basiese Evalueringe (BE's) vir die voorgestelde ontwikkeling van die bogenoemde Substasies en Kraglyne naby Loeriesfontein in die Noord-Kaap Provinsie te onderneem.

Ons lig u graag hiermee in dat die Konsep Basiese Evalueringsverslae (KBEV's) vir die bogenoemde projekte, ooreenkomstig die Nasionale Wet op Omgewingsbestuur (NEMA) (soos gewysig), vanaf **Donderdag 14 Desember 2017** tot **Maandag 05 Februarie 2018** (voor die einde van die werksdag) beskikbaar gemaak sal wees vir openbare oorsig en kommentaar. Gedrukte kopieë van die KBEV's is beskikbaar by die plek wat hieronder genoem word:

PLEK	STRAATADRES	TYE	KONTAKNOMMER
Loeriesfontein Biblioteek	Mainstraat, Loeriesfontein	Maandae – Vrydae 14h00 – 17h00	027 662 8607

Die verslae sowel as die meegaande aanhangsels is ook beskikbaar op SiVEST se webwerf: <http://www.sivest.co.za>. Klik op 'Downloads' en soek dan vir die gids '13622 Mainstream Substations and Power Lines'.

Aangeheg is Engelse en Afrikaanse briewe wat u inlig oor die beskikbaarheid van die verslae, insluitende Kommentaarvorms.

Ons versoek u vriendelik om u kommentaar by die publieke deelnemende kantoor in te dien by die onderstaande besonderhede, voor of op **Maandag 05 Februarie 2018** (voor die einde van die werksdag). SiVEST sal enige kommentaar wat na die openbare kommentaar en oorsigperiode ontvang word, direk aan die betrokke saakbeampte by die Departement van Omgewingsake (DEA) stuur.

Indien u enige vrae of navrae het, moet asseblief nie huiwer om ons te kontak by:

Stephan Jacobs / Hlengiwe Ntuli

Posbus 2921, Rivonia, 2128

Tel – (011) 798 0600

Faks – (011) 803 7272

E-pos – stephanj@sivest.co.za / hlengiwen@sivest.co.za

Vriendelike groete,

Kind Regards

Andrea Gibb

Senior Manager

SiVEST Environmental Division





The text in this area is too small to be read accurately. It appears to be a header or a small note.



SIVEST is a Level 3 BBBEE Contributor

Direct +27 11 798 0638 **Tel** +27 11 798 0600 **fax** +27 11 803 7272
email andreag@sivest.co.za **website** www.sivest.co.za

Consulting Engineers - Project Managers - Environmental Consultants - Town and Regional Planners
Durban - Johannesburg - Pietermaritzburg - Richards Bay - Ladysmith - Cape Town - Harare (Zimbabwe)

Disclaimer

The information contained in this communication from the sender is confidential. It is intended solely for use by the recipient and others authorized to receive it. If you are not the recipient, you are hereby notified that any disclosure, copying, distribution or taking action in relation of the contents of this information is strictly prohibited and may be unlawful.

This email has been scanned for viruses and malware, and automatically archived by **Mimecast SA (Pty) Ltd**, an innovator in Software as a Service (SaaS) for business. **Mimecast Unified Email Management ??? (UEM)** offers email continuity, security, archiving and compliance with all current legislation. To find out more, [contact Mimecast](#).

Stephan Jacobs

From: sivest_PPP
Sent: Thursday, January 11, 2018 2:09 PM
Cc: Andrea Gibb; Stephan Jacobs; 'Nicolene Venter'; 'rebecca.thomas@mainstreamrp.com'
Subject: Four (4) Proposed Mainstream Wind Farms near Loeriesfontein- Draft Minutes for Landowner FGM held on 1 Nov 2017

******* Please note that this email was sent from a NO REPLY email address. Please do not reply to this address as it is an unmonitored email account.*******

Dear Landowners,

Please find attached for your convenience the Draft Minutes of the Landowner Focus Group Meeting (FGM) which was held on Wednesday 01 November 2017 for the four (4) proposed Mainstream Wind Farms near Loeriesfontein in the Northern Cape Province (i.e. Graskoppies Wind Farm, Hartebeest Leegte Wind Farm, Ithemba Wind Farm and Xha! Boom Wind Farm).

Please feel free to contact us should there be any problems.



13622 Leeuwberg
FGM LOs_Draft ...

Kind Regards,

Stephan Jacobs *(B.Sc.(Hons) Environmental Management and Analysis)*

Environmental Consultant

SiVEST Environmental Division



SiVEST is a Level 3 BBBEE Contributor

Direct +27 11 798 0677 **Tel** +27 11 798 0600 **fax** +27 11 803 7272

email stephanj@sivest.co.za **website** www.sivest.co.za



Consulting Engineers - Project Managers - Environmental Consultants - Town and Regional Planners
Durban - Johannesburg - Pietermaritzburg - Richards Bay - Ladysmith - Port Louis (Mauritius)

Stephan Jacobs

From: sivist_PPP
Sent: Wednesday, January 31, 2018 8:36 AM
To: Andrea Gibb; Stephan Jacobs; 'rebecca.thomas@mainstreamrp.com'; 'Nicolene Venter'
Cc: 'John Geeringh'; 'Heleen van den Heever'; 'Morgan Griffiths'; 'Obakeng Isaacs'; 'P Josop'; 'Brian Fisher'; 'Henning Myburg'; 'Sam Fiff'; 'Amanda Bester'; 'Riaan Van Wyk'; 'Natasha Higgitt'; 'Nicole Abrahams'; 'Ted Williams'; 'Chris Coetzee'; 'Hettie Buys'; 'Thoko Buthelezi'; 'Mmatlala Rabothata'; 'Marianne Golding'; 'Simphiwe Masilela'; 'Candice Stevens'; 'Johanna Morobane'; 'Lizell Stroh'; 'Adriaan Tiplady'; 'Ramatholo Sefako'; 'Samantha Ralston-Paton'; 'Gert Steenkamp'; 'Moses Mahunonyane'; 'Johan Koegelenberg'; 'Lourens Leeuwner'; 'Stanley Tshitwamulomoni'; 'Candice Spammer'; 'Seoka Lekota'; 'Jaco Roelofse'; 'Patrick Lenyibi'; 'Ester Makungo'; 'Garth Julius'; 'Jannie Loubser'; 'ruth.cuttings@yahoo.com'; 'kmotlhom@ncpg.gov.za'; 'lefleurd@dws.gov.za'; 'BesterAD@telkom.co.za'
Subject: RE: Proposed Mainstream Substations and Power Lines for the Wind Farms near Loeriesfontein: DBARs Comment Period Ending
Importance: High

******* Please note that this email was sent from a NO REPLY email address. Please do not reply to this address as it is an unmonitored email account.*******

Dear Stakeholder,

BASIC ASSESSMENTS (BAS) FOR THE PROPOSED DEVELOPMENT OF THE 132KV MAINSTREAM LINKING SUBSTATION AND FOUR (4) 132KV ON-SITE ESKOM SUBSTATIONS AND POWER LINES NEAR LOERIESFONTEIN, NORTHERN CAPE PROVINCE

- **132kV Graskoppies Substations and Power line – (DEA Ref No.: To be Announced)**
- **132kV Hartbeest Leegte Substations and Power Line – (DEA Ref No.: To be Announced)**
- **132kV Ithemba Substations and Power Line – DEA Ref No.: To be Announced)**
- **132kV !Xha Boom Substations and Power Line – DEA Ref No.: To be Announced)**

Please note that the final day for comments on the Draft Basic Assessments Reports (DBARs) for the above mentioned wind farm projects is **on Monday 05 February 2018**.

This email serves as a reminder to please submit any comments by the close of business on the **Monday 05 February 2018 (COB)**

Should you have any comments, please feel free to contact the public participation office at the details below:

SiVEST Environmental

Hlengiwe Ntuli / Stephan Jacobs
PO BOX 2921
Rivonia
2128
Tel: 011 798 0600
Fax: 011 803 7272
Email: hlengiwen@sivest.co.za / stephanj@sivest.co.za



13622 DBAR

Notification Lett...



13622 DBAR

Kind Regards
Andrea Gibb
Senior Manager
SiVEST Environmental Division



SiVEST is a Level 3 BBBEE Contributor



Direct +27 11 798 0638 **Tel** +27 11 798 0600 **fax** +27 11 803 7272
email andreaq@sivest.co.za **website** www.sivest.co.za



Consulting Engineers - Project Managers - Environmental Consultants - Town and Regional Planners
Durban - Johannesburg - Pietermaritzburg - Richards Bay - Ladysmith - Cape Town - Harare (Zimbabwe)

From: sivest_PPP

Sent: 14 December 2017 04:54 PM

To: Andrea Gibb <AndreaG@sivest.co.za>; Stephan Jacobs <StephanJ@sivest.co.za>;
'rebecca.thomas@mainstreamrp.com' <rebecca.thomas@mainstreamrp.com>; 'Nicolene Venter'
<nicolene@imaginativeafrica.co.za>

Cc: 'John Geeringh' <GeerinJH@eskom.co.za>; 'Heleen van den Heever' <vdheevhd@telkom.co.za>; 'Morgan Griffiths'
<morgan.griffiths@wessa.co.za>; 'Obakeng Isaacs' <munman@khaima.gov.za>; 'P Josop'
<commonage@khaima.gov.za>; 'Brian Fisher' <bfisher@ncpg.gov.za>; 'Henning Myburg' <henning@agrink.co.za>; 'Sam Fiff'
<Francis.Rahlapane@transnet.net>; 'Amanda Bester' <WayleaCR@telkom.co.za>; 'Riaan Van Wyk'
<socialdev1@hantam.gov.za>; 'Natasha Higgitt' <nhiggitt@sahra.org.za>; 'Nicole Abrahams' <AbrahamsN@nra.co.za>;
'Ted Williams' <williams@saa.ac.za>; 'Chris Coetzee' <chris@salt.ac.za>; 'Hettie Buys' <HettieB@daff.gov.za>; 'Thoko
Buthelezi' <ThokoB@daff.gov.za>; 'Mmatlala Rabothata' <mrabothata@environment.gov.za>; 'Marianne Golding'
<marianneg@ewt.org.za>; 'Simphiwe Masilela' <ObstacleEvaluators@atns.co.za>; 'Candice Stevens'
<advocacy@birdlife.org.za>; 'Johanna Morobane' <JohannaM@atns.co.za>; 'Lizell Stroh' <strohl@caa.co.za>; 'Adriaan
Tiplady' <atiplady@ska.ac.za>; 'Ramatholo Sefako' <rrs@saa.ac.za>; 'Samantha Ralston-Paton'
<energy@birdlife.org.za>; 'Gert Steenkamp' <gsteenkamp@ncpg.gov.za>; 'Moses Mahunonyane'
<MahunonyaneM@dws.gov.za>; 'Johan Koegelenberg' <KoegelenbergJ@sentech.co.za>; 'Lourens Leeuwner'
<lourensl@ewt.org.za>; 'Stanley Tshitwamulomoni' <StanleyT@environmental.gov.za>; 'Candice Spammer'
<spammec1@telkom.co.za>; 'Seoka Lekota' <slekota@environment.gov.za>; 'Jaco Roelofse'
<roelofse.j@vodamail.co.za>; 'Patrick Lenyibi' <plenyibi@ncpg.gov.za>; 'Ester Makungo' <makungoe@dws.gov.za>;
'Garth Julius' <JuliusG@nra.co.za>; 'Jannie Loubser' <janniell@namakwa-dm.gov.za>; 'ruth.cuttings@yahoo.com'
<ruth.cuttings@yahoo.com>; 'kmotlhomi@ncpg.gov.za' <kmotlhomi@ncpg.gov.za>; 'lefleurd@dws.gov.za'
<lefleurd@dws.gov.za>; 'BesterAD@telkom.co.za' <BesterAD@telkom.co.za>

Subject: Proposed Mainstream Substations and Power Lines for the Wind Farms near Loeriesfontein: DBARs Available for Review

******* Please note that this email was sent from a NO REPLY email address. Please do not reply to this address as it is an unmonitored email account.*******

BASIC ASSESSMENTS (BAS) FOR THE PROPOSED DEVELOPMENT OF THE 132KV MAINSTREAM LINKING SUBSTATION AND FOUR (4) 132KV ON-SITE ESKOM SUBSTATIONS AND POWER LINES NEAR LOERIESFONTEIN, NORTHERN CAPE PROVINCE

- 132kV Graskoppies Substations and Power line – (DEA Ref No.: To be Announced)
- 132kV Hartbeest Leegte Substations and Power Line – (DEA Ref No.: To be Announced)
- 132kV Ithemba Substations and Power Line – DEA Ref No.: To be Announced)
- 132kV !Xha Boom Substations and Power Line – DEA Ref No.: To be Announced)

SiVEST is in the process of undertaking the Basic Assessments (BAs) for the proposed development of the above-mentioned Substations and Power Lines near Loeriesfontein in the Northern Cape Province.

We would like to take this opportunity to inform you that, in accordance with the National Environmental Management Act (NEMA) (as amended), the Draft Basic Assessment Reports (DBARs) will be made available for public comment and review as from **Thursday 14 December 2017 to Monday 05 February 2018** (before end of business day).

The DBARs as well as the accompanying appendices are available online ([http://www.sivest.co.za/](http://www.sivest.co.za) click on 'Downloads' and navigate to '13622 Mainstream Substations and Power Lines') and an electronic copy (on CD) has been posted to you. We kindly request that you submit your comments to Public Participation Office at the below details, on or before **Monday 05 February 2018** (before end of business day). SiVEST will forward any comments received after the public comment and review period directly to the relevant case officer at the Department of Environmental Affairs (DEA).

Should you have any questions or queries please do not hesitate to contact us at:

Stephan Jacobs / Hlengiwe Ntuli

PO BOX 2921, Rivonia, 2128

Tel – (011) 798 0600

Fax – (011) 803 7272

Email – stephanj@sivest.co.za /
hlengiwen@sivest.co.za

Kind Regards

Andrea Gibb

Senior Manager

SiVEST Environmental Division

<< OLE Object: Picture (Device Independent Bitmap) >>

SiVEST is a Level 3 BBBEE Contributor

Direct +27 11 798 0638 **Tel** +27 11 798 0600 **fax** +27 11 803 7272

email andrea@sivest.co.za **website** www.sivest.co.za



Consulting Engineers - Project Managers - Environmental Consultants - Town and Regional Planners
Durban - Johannesburg - Pietermaritzburg - Richards Bay - Ladysmith - Cape Town - Harare (Zimbabwe)

Hlengiwe Ntuli

From: Stephan Jacobs
Sent: Monday, 05 February 2018 2:33 PM
To: Irene Bezuidenhout; Hlengiwe Ntuli
Cc: Andrea Gibb; rebecca.thomas@mainstreamrp.com; Michael Barnes; Tonderai Munthumbira; Armandt Joubert; Daniel Lowings; Zwai Ntuli
Subject: RE: 13622 Proposed Substations and Power Lines for the Wind Farms near Loeriesfontein: DBAR Comment Period Starting

Hi Irene,

Comments received. Thank you very much for these. They have been duly noted and will be forwarded to Mainstream for consideration.

Kind Regards,

Stephan Jacobs (*B.Sc.(Hons) Environmental Management and Analysis*)
Environmental Consultant
SiVEST Environmental Division



SiVEST is a Level 3 BBBEE Contributor

Direct +27 11 798 0677 **Tel** +27 11 798 0600 **fax** +27 11 803 7272 **cell** +27 72 737 2114
email stephanj@sivest.co.za **website** www.sivest.co.za



Consulting Engineers - Project Managers - Environmental Consultants - Town and Regional Planners - Quality Management Consultants
Durban - Johannesburg - Pretoria - Pietermaritzburg - Richards Bay - Port Louis (Mauritius)

From: Irene Bezuidenhout [mailto:iBezuidenhout@biothermenergy.com]
Sent: Monday, February 5, 2018 2:29 PM
To: Stephan Jacobs; Hlengiwe Ntuli
Cc: Andrea Gibb; rebecca.thomas@mainstreamrp.com; Michael Barnes; Tonderai Munthumbira; Armandt Joubert; Daniel Lowings; Zwai Ntuli
Subject: RE: 13622 Proposed Substations and Power Lines for the Wind Farms near Loeriesfontein: DBAR Comment Period Starting

Dear Stephan,

Thank you for giving us an opportunity to comment on the DBARs for the proposed Mainstream power lines near Loeriesfontein and for providing us with the kmz files.

As mentioned in our previous correspondence, BioTherm Energy has Environmental Authorisation for the proposed Loeriesfontein 70MW PV energy facility (DEA Ref: 12/12/20/2632) on Portion 5 of the Farm Kleine Rooiberg No. 227 as well as Environmental Authorisation for a proposed 132kV power line to link the Loeriesfontein PV facility to the Eskom Helios MTS (DEA Ref: 14/12/16/3/3/1/536). The power line route is traversing Portion 5 of the Farm Kleine Rooiberg No. 227; Remainder of the Farm Kleine Rooiberg No. 227 and Remainder of the Farm Sous No. 226. Based on a desktop review on Google Earth, it does not appear as if the proposed Mainstream power line options will have any impact to BioTherm Energy's already authorised Loeriesfontein PV Energy facility or its 132kV power line linking to the Helios substation. Please see screenshot below:

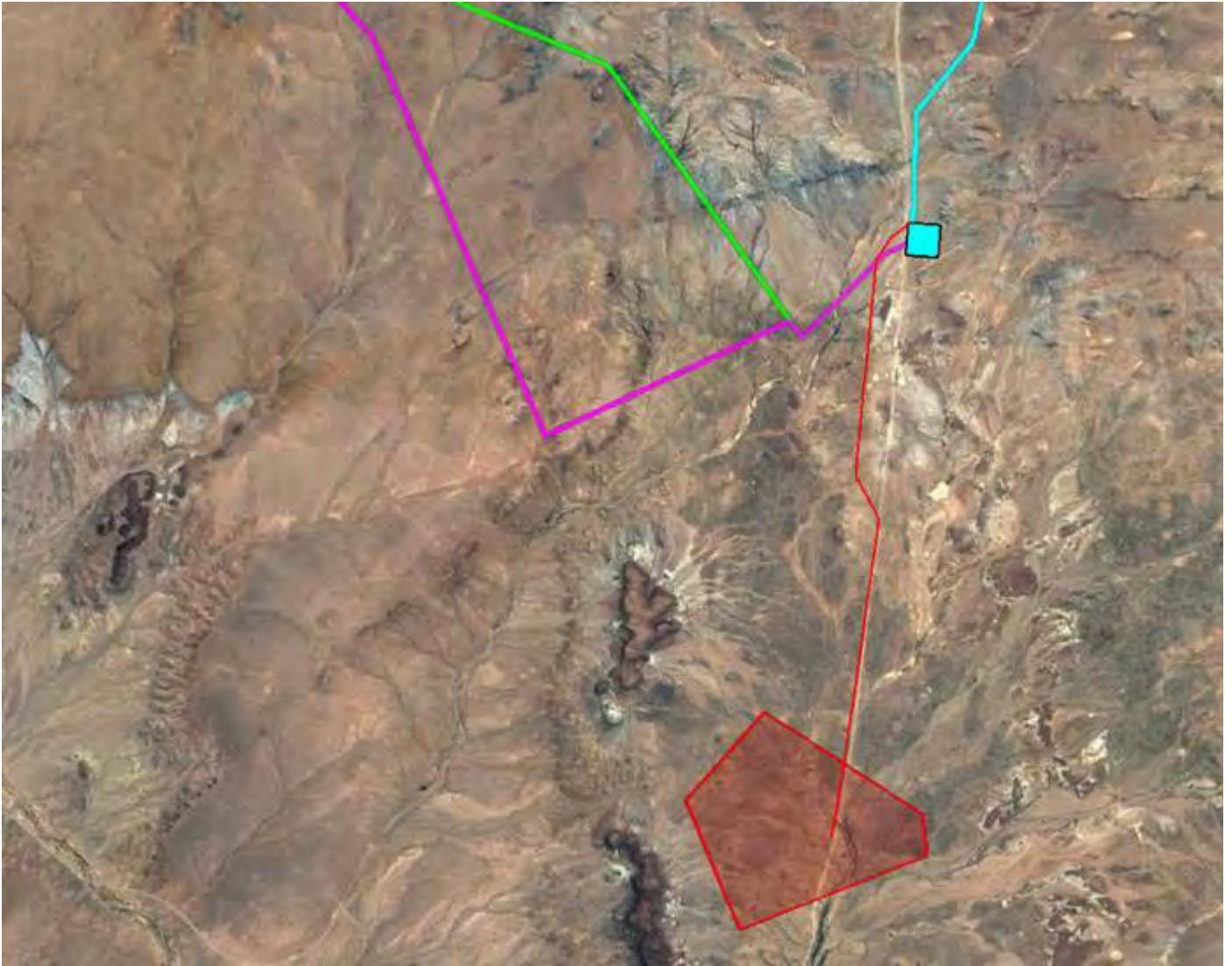

The red polygon depicts our authorised PV facility site and the red line depicts the authorised 132kV power line route to Helios substation. There may be line crossings where the power lines have to connect into Helios substation, but I don't foresee that being an issue currently. Discussions can be held between us, Mainstream and Eskom at a later stage when one of the projects advances to being a preferred bidder. I have attached the kmz of our authorised facility area and power line alignment for inclusion into the FBAR. We would appreciate it if our authorised project area and power line route can be taken note of and kept on record during the advancement of the Mainstream projects.

Please don't hesitate to contact me should you wish to discuss our comments in further detail.

Kind regards

Irene Bezuidenhout | Environmental Manager
BioTherm Energy (Pty) Ltd
Building 1, Leslie Ave East Design Quarter District, Fourways
P: +27 (0) 11 367 4600 | F: +27 (0) 11 367 4601 | M: +27 (0) 76 822 3484
E: lbezuidenhout@biothermenergy.com



www.biothermenergy.com



Please note that confidential information may be contained in this message. If you are not the addressee indicated in this message you may not copy or deliver this message to anyone. In that event, you should destroy this message and kindly notify the sender by reply e-mail. Any opinions, conclusions and other information contained in this message that do not relate to the official business of BioTherm Energy Group of Companies are neither given nor endorsed by it.

From: Stephan Jacobs [<mailto:StephanJ@sivest.co.za>]
Sent: Friday, 15 December, 2017 12:01 PM
To: Irene Bezuidenhout <iBezuidenhout@biothermenergy.com>; Hlengiwe Ntuli <HlengiweN@sivest.co.za>
Cc: Andrea Gibb <AndreaG@sivest.co.za>; rebecca.thomas@mainstreamrp.com; Michael Barnes <mbarnes@biothermenergy.com>
Subject: RE: 13622 Proposed Substations and Power Lines for the Wind Farms near Loeriesfontein: DBAR Comment Period Starting
Importance: High

Hi Irene,

As requested, please find attached KMLs for the proposed substation and power line projects Mainstream are proposing near Loeriesfontein. These substations and power lines will connect the proposed Graskoppies, Hartebeest Leegte, Ithemba and !Xha Boom Wind Farms to the national grid at Helios MTS.

Please note that corridor Option 4 is Mainstream's preferred power line corridor option.

Kind Regards,

Stephan Jacobs (*B.Sc.(Hons) Environmental Management and Analysis*)
Environmental Consultant
SIVEST Environmental Division



SIVEST is a Level 3 BBBEE Contributor

 **CESA** Direct +27 11 798 0677 Tel +27 11 798 0600 fax +27 11 803 7272 cell +27 72 737 2114
email stephanj@sivest.co.za website www.sivest.co.za

Consulting Engineers - Project Managers - Environmental Consultants - Town and Regional Planners - Quality Management Consultants
Durban - Johannesburg - Pretoria - Pietermaritzburg - Richards Bay - Port Louis (Mauritius)

SIVEST offices will be closing for the Christmas and New Year holiday season break from 16h00 on Wednesday, 20th December 2017 and will re-open at 08h00 on Monday, 8th January 2018

From: Irene Bezuidenhout [<mailto:iBezuidenhout@biothermenergy.com>]
Sent: Friday, December 15, 2017 11:18 AM
To: Stephan Jacobs; Hlengiwe Ntuli
Cc: Andrea Gibb; rebecca.thomas@mainstreamrp.com; Michael Barnes
Subject: RE: 13622 Proposed Substations and Power Lines for the Wind Farms near Loeriesfontein: DBAR Comment Period Starting

Hi Stephan,

Thank you for the notification. Please can you provide me with a kmz file for the proposed powerline route options in order for us to provide comment if necessary. BioTherm Energy has an EA for the proposed 70MW Loeriesfontein

PV facility and a separate EA for a 132kV powerline to Helios substation, I need to see if the proposed routes will impact on our authorised site and layout and/or authorised route alignment to Helios substation. We understand that the IPPs infrastructure have to coexist and we need to come up with an optimal solution which will suit all parties should there be a potential impact to our authorised infrastructure.

Kind regards

Irene Bezuidenhout | Environmental Manager
BioTherm Energy (Pty) Ltd
Building 1, Leslie Ave East Design Quarter District, Fourways
P: +27 (0) 11 367 4600 | F: +27 (0) 11 367 4601 | M:+27 (0) 76 822 3484
E: lbezuidenhout@biothermenergy.com



www.biothermenergy.com



Please note that confidential information may be contained in this message. If you are not the addressee indicated in this message you may not copy or deliver this message to anyone. In that event, you should destroy this message and kindly notify the sender by reply e-mail. Any opinions, conclusions and other information contained in this message that do not relate to the official business of BioTherm Energy Group of Companies are neither given nor endorsed by it.

From: sivist_PPP [mailto:sivist_ppp@sivest.co.za]
Sent: Thursday, 14 December, 2017 4:49 PM
Cc: Andrea Gibb <AndreaG@sivest.co.za>; Stephan Jacobs <StephanJ@sivest.co.za>; 'rebecca.thomas@mainstreamrp.com' <rebecca.thomas@mainstreamrp.com>; 'Nicolene Venter' <nicolene@imaginativeafrica.co.za>
Subject: 13622 Proposed Substations and Power Lines for the Wind Farms near Loeriesfontein: DBAR Comment Period Starting

******* Please note that this email was sent from a NO REPLY email address. Please do not reply to this address as it is an unmonitored email account.*******

Dear Interested and/or Affected Party,

BASIC ASSESSMENTS (BAS) FOR THE PROPOSED DEVELOPMENT OF THE 132kV MAINSTREAM LINKING SUBSTATION AND FOUR (4) 132kV ON-SITE ESKOM SUBSTATIONS AND POWER LINES NEAR LOERIESFONTEIN, NORTHERN CAPE PROVINCE

- **132kV Graskoppies Substations and Power line**
– (DEA Ref No.: To be Announced)

- **132kV Hartebeest Leegte Substations and Power Line**
– (DEA Ref No.: To be Announced)

- **132kV Ithemba Substations and Power Line**
– (DEA Ref No.: To be Announced)

- **132kV !Xha Boom Substations and Power Line**
– (DEA Ref No.: To be Announced)

- **AVAILABILITY OF THE DRAFT BASIC ASSESSMENT REPORTS FOR PUBLIC REVIEW**

SiVEST is in the process of undertaking the Basic Assessments (BAs) for the proposed development of the above mentioned Substations and Power Lines near Loeriesfontein in the Northern Cape Province.

We would like to inform you that, in accordance with the National Environmental Management Act (NEMA) (as amended), the Draft Basic Assessment Reports (DBARs) for the above-mentioned projects will be made available for public review and comment as from **Thursday 14 December 2017 to Monday 05 February 2018** (before end of business day). Hard copies of the DBARs are available at the following venue:

VENUE	STREET ADDRESS	HOURS	CONTACT NO
Loeriesfontein Library	Main Street, Loeriesfontein	Mondays – Fridays 14h00 – 17h00	027 662 8607

The reports as well as the accompanying appendices are also available on SiVEST's website: <http://www.sivest.co.za/>, click on downloads, then browse to the folder '13622 Mainstream Substations and Power Lines'.

Attached are English and Afrikaans letters notifying you of the availability of the reports, including Comment Forms.

We kindly request that you submit your comments to Public Participation Office at the below details, on or before **Monday 05 February 2018** (before end of business day). SiVEST will forward any comments received after the public comment and review period directly to the relevant case officer at the Department of Environmental Affairs (DEA).

Should you have any questions or queries please do not hesitate to contact us at:

Stephan Jacobs / Hlengiwe Ntuli

PO BOX 2921, Rivonia, 2128

Tel – (011) 798 0600

Fax – (011) 803 7272

Email – stephanj@sivest.co.za / hlengiwen@sivest.co.za

Kind Regards

ONDERWERP: 13622 Voorgestelde Substasies en Kraglyne vir doe Windplase naby Loeriesfontein: KBEV
Kommentaar Periode Begin

Geagte Belangstellende en/of Geaffekteerde Party,

**BASIESE EVALUERINGS (BE's) VIR DIE BEOOGDE ONTWIKKELING VAN DIE 132KV MAINSTREAM SKAKEL
SUBSTASIE EN VIER (4) 132KV OP PERSEEL ESKOM SUBSTASIES EN KRAGLYNE NABY LOERIESFONTEIN,
NOORD-KAAP PROVINSIE**

- **132kV Graskoppies Substasies en Kraglyn**
– (DEA Verwysings No.: Moet nog aangekondig word)
- **132kV Hartbeest Leegte Substasies en Kraglyn**
– (DEA Verwysings No.: Moet nog aangekondig word)
- **132kV Ithemba Substasies en Kraglyn**
– DEA Verwysings No.: Moet nog aangekondig word)
- **132kV !Xha Boom Substasies en Kraglyn**

– DEA Verwysings No.: Moet nog aangekondig word)

• **BESKIKBAARHEID VAN DIE KONSEP BASIESE EVALUERINGSVERSLAE VIR OPENBARE OORSIG**

SiVEST is in die proses om die Basiese Evalueringe (BE's) vir die voorgestelde ontwikkeling van die bogenoemde Substasies en Kraglyne naby Loeriesfontein in die Noord-Kaap Provinsie te onderneem.

Ons lig u graag hiermee in dat die Konsep Basiese Evalueringsverslae (KBEV's) vir die bogenoemde projekte, ooreenkomstig die Nasionale Wet op Omgewingsbestuur (NEMA) (soos gewysig), vanaf **Donderdag 14 Desember 2017** tot **Maandag 05 Februarie 2018** (voor die einde van die werksdag) beskikbaar gemaak sal wees vir openbare oorsig en kommentaar. Gedrukte kopieë van die KBEV's is beskikbaar by die plek wat hieronder genoem word:

PLEK	STRAATADRES	TYE	KONTAKNOMMER
Loeriesfontein Biblioteek	Mainstraat, Loeriesfontein	Maandae – Vrydae 14h00 – 17h00	027 662 8607

Die verslae sowel as die meegaande aanhangsels is ook beskikbaar op SiVEST se webwerf: <http://www.sivest.co.za>. Klik op 'Downloads' en soek dan vir die gids '13622 Mainstream Substations and Power Lines'.

Aangeheg is Engelse en Afrikaanse briewe wat u inlig oor die beskikbaarheid van die verslae, insluitende Kommentaarvorms.

Ons versoek u vriendelik om u kommentaar by die publieke deelnemende kantoor in te dien by die onderstaande besonderhede, voor of op **Maandag 05 Februarie 2018** (voor die einde van die werksdag). SiVEST sal enige kommentaar wat na die openbare kommentaar en oorsigperiode ontvang word, direk aan die betrokke saakbeampte by die Departement van Omgewingsake (DEA) stuur.

Indien u enige vrae of navrae het, moet asseblief nie huiwer om ons te kontak by:

Stephan Jacobs / Hlengiwe Ntuli

Posbus 2921, Rivonia, 2128

Tel – (011) 798 0600

Faks – (011) 803 7272

E-pos – stephanj@sivest.co.za / hlengiwen@sivest.co.za

Vriendelike groete,

Kind Regards

Andrea Gibb

Senior Manager

SiVEST Environmental Division





SIVEST is a Level 3 BBBEE Contributor

Direct +27 11 798 0638 **Tel** +27 11 798 0600 **fax** +27 11 803 7272
email andreaq@sivest.co.za **website** www.sivest.co.za

Consulting Engineers - Project Managers - Environmental Consultants - Town and Regional Planners
Durban - Johannesburg - Pietermaritzburg - Richards Bay - Ladysmith - Cape Town - Harare (Zimbabwe)

Disclaimer

The information contained in this communication from the sender is confidential. It is intended solely for use by the recipient and others authorized to receive it. If you are not the recipient, you are hereby notified that any disclosure, copying, distribution or taking action in relation of the contents of this information is strictly prohibited and may be unlawful.

This email has been scanned for viruses and malware, and automatically archived by Mimecast SA (Pty) Ltd, an innovator in Software as a Service (SaaS) for business. Mimecast Unified Email Management ??? (UEM) offers email continuity, security, archiving and compliance with all current legislation. To find out more, [contact Mimecast](#).

Disclaimer

The information contained in this communication from the sender is confidential. It is intended solely for use by the recipient and others authorized to receive it. If you are not the recipient, you are hereby notified that any disclosure, copying, distribution or taking action in relation of the contents of this information is strictly prohibited and may be unlawful.

This email has been scanned for viruses and malware, and automatically archived by Mimecast SA (Pty) Ltd, an innovator in Software as a Service (SaaS) for business. Mimecast Unified Email Management ??? (UEM) offers email continuity, security, archiving and compliance with all current legislation. To find out more, [contact Mimecast](#).

Hlengiwe Ntuli

From: Stephan Jacobs
Sent: Monday, 05 February 2018 7:17 PM
To: Stephnie Kot
Cc: Andrea Gibb; 'rebecca.thomas@mainstreamrp.com'; Hlengiwe Ntuli; Mary Waller
Subject: RE: Comment on the Draft BAR: Proposed Substations and Power Lines for the Wind Farms near Loeriesfontein

Importance: High

Good day Stephnie,

Comments received. Thank you very much for these.

We will make sure that the comments are brought to Mainstream's attention for consideration and are incorporated into the Final Basic Assessment Reports (FBARs) for the respective projects.

Kind Regards,

Stephan Jacobs (*B.Sc.(Hons) Environmental Management and Analysis*)
Environmental Consultant
SiVEST Environmental Division



SiVEST is a Level 3 BBBEE Contributor

Direct +27 11 798 0677 **Tel** +27 11 798 0600 **fax** +27 11 803 7272 **cell** +27 72 737 2114
email stephanj@sivest.co.za **website** www.sivest.co.za



Consulting Engineers - Project Managers - Environmental Consultants - Town and Regional Planners - Quality Management Consultants
Durban - Johannesburg - Pretoria - Pietermaritzburg - Richards Bay - Port Louis (Mauritius)

From: Stephnie Kot [mailto:stephnie.kot@aced.co.za]
Sent: Monday, February 5, 2018 5:02 PM
To: sivest_PPP; Stephan Jacobs
Cc: Andrea Gibb; 'rebecca.thomas@mainstreamrp.com'; Hlengiwe Ntuli; Mary Waller
Subject: RE: Comment on the Draft BAR: Proposed Substations and Power Lines for the Wind Farms near Loeriesfontein

Good day Stephan,

With reference to the below notification, please find attached comment submitted on behalf of Business Venture Investments No. 1788 (Pty) Ltd, in response to the draft Basic Assessment Reports for the proposed Graskoppies, Haartebeest Leegte, Ithemba and !Xha Boom 132kV Powerlines.

Please confirm receipt of the attached, and don't hesitate to contact me should you wish to discuss.

Thank you.

Kind Regards,

Stephnie Kot

o.b.o. Business Venture Investments No. 1788 (Pty) Ltd

Email: stephnie.kot@aced.co.za

Tel: 021 670 1423

Cell: 083 318 3982

From: sivist_PPP [mailto:sivist_ppp@sivest.co.za]

Sent: 14 December 2017 04:49 PM

Cc: Andrea Gibb <AndreaG@sivest.co.za>; Stephan Jacobs <StephanJ@sivest.co.za>; 'rebecca.thomas@mainstreamrp.com' <rebecca.thomas@mainstreamrp.com>; 'Nicolene Venter' <nicolene@imaginativeafrica.co.za>

Subject: 13622 Proposed Substations and Power Lines for the Wind Farms near Loeriesfontein: DBAR Comment Period Starting

******* Please note that this email was sent from a NO REPLY email address. Please do not reply to this address as it is an unmonitored email account.*******

Dear Interested and/or Affected Party,

BASIC ASSESSMENTS (BAS) FOR THE PROPOSED DEVELOPMENT OF THE 132kV MAINSTREAM LINKING SUBSTATION AND FOUR (4) 132kV ON-SITE ESKOM SUBSTATIONS AND POWER LINES NEAR LOERIESFONTEIN, NORTHERN CAPE PROVINCE

- **132kV Graskoppies Substations and Power line**
– (DEA Ref No.: To be Announced)
- **132kV Hartebeest Leege Substations and Power Line**
– (DEA Ref No.: To be Announced)
- **132kV Ithemba Substations and Power Line**
– (DEA Ref No.: To be Announced)
- **132kV !Xha Boom Substations and Power Line**
– (DEA Ref No.: To be Announced)

- **AVAILABILITY OF THE DRAFT BASIC ASSESSMENT REPORTS FOR PUBLIC REVIEW**

SiVEST is in the process of undertaking the Basic Assessments (BAs) for the proposed development of the above mentioned Substations and Power Lines near Loeriesfontein in the Northern Cape Province.

We would like to inform you that, in accordance with the National Environmental Management Act (NEMA) (as amended), the Draft Basic Assessment Reports (DBARs) for the above-mentioned projects will be made available for public review and comment as from **Thursday 14 December 2017** to **Monday 05 February 2018** (before end of business day). Hard copies of the DBARs are available at the following venue:

VENUE	STREET ADDRESS	HOURS	CONTACT NO
Loeriesfontein Library	Main Street, Loeriesfontein	Mondays – Fridays 14h00 – 17h00	027 662 8607

The reports as well as the accompanying appendices are also available on SiVEST's website: <http://www.sivest.co.za/>, click on downloads, then browse to the folder '13622 Mainstream Substations and Power Lines'.

Attached are English and Afrikaans letters notifying you of the availability of the reports, including Comment Forms.

We kindly request that you submit your comments to Public Participation Office at the below details, on or before **Monday 05 February 2018** (before end of business day). SiVEST will forward any comments received after the public comment and review period directly to the relevant case officer at the Department of Environmental Affairs (DEA).

Should you have any questions or queries please do not hesitate to contact us at:

Stephan Jacobs / Hlengiwe Ntuli

PO BOX 2921, Rivonia, 2128

Tel – (011) 798 0600

Fax – (011) 803 7272

Email – stephanj@sivest.co.za / hlengiwen@sivest.co.za

Kind Regards

ONDERWERP: 13622 Voorgestelde Substasies en Kraglyne vir doe Windplase naby Loeriesfontein: KBEV
Kommentaar Periode Begin

Geagte Belangstellende en/of Geaffecteerde Party,

**BASIESE EVALUERINGS (BE's) VIR DIE BEOOGDE ONTWIKKELING VAN DIE 132KV MAINSTREAM SKAKEL
SUBSTASIE EN VIER (4) 132KV OP PERSEEL ESKOM SUBSTASIES EN KRAGLYNE NABY LOERIESFONTEIN,
NOORD-KAAP PROVINSIE**

- **132kV Graskoppies Substasies en Kraglyn**
– (DEA Verwysings No.: Moet nog aangekondig word)
- **132kV Hartbeest Leegte Substasies en Kraglyn**
– (DEA Verwysings No.: Moet nog aangekondig word)
- **132kV Ithemba Substasies en Kraglyn**
– DEA Verwysings No.: Moet nog aangekondig word)
- **132kV !Xha Boom Substasies en Kraglyn**
– DEA Verwysings No.: Moet nog aangekondig word)
- **BESKIKBAARHEID VAN DIE KONSEP BASIESE EVALUERINGSVERSLAE VIR OPENBARE OORSIG**

SiVEST is in die proses om die Basiese Evaluerings (BE's) vir die voorgestelde ontwikkeling van die bogenoemde Substasies en Kraglyne naby Loeriesfontein in die Noord-Kaap Provinsie te onderneem.

Ons lig u graag hiermee in dat die Konsep Basiese Evalueringsverslae (KBEV's) vir die bogenoemde projekte, ooreenkomstig die Nasionale Wet op Omgewingsbestuur (NEMA) (soos gewysig), vanaf **Donderdag 14 Desember 2017** tot **Maandag 05 Februarie 2018** (voor die einde van die werksdag) beskikbaar gemaak sal wees vir openbare oorsig en kommentaar. Gedrukte kopieë van die KBEV's is beskikbaar by die plek wat hieronder genoem word:

PLEK	STRAATADRES	TYE	KONTAKNOMMER
Loeriesfontein Biblioteek	Mainstraat, Loeriesfontein	Maandae – Vrydae 14h00 – 17h00	027 662 8607

Die verslae sowel as die meegaande aanhangsels is ook beskikbaar op SiVEST se webwerf: <http://www.sivest.co.za>. Klik op 'Downloads' en soek dan vir die gids '13622 Mainstream Substations and Power Lines'.

Aangeheg is Engelse en Afrikaanse briewe wat u inlig oor die beskikbaarheid van die verslae, insluitende Kommentaarvorms.

Ons versoek u vriendelik om u kommentaar by die publieke deelnemende kantoor in te dien by die onderstaande besonderhede, voor of op **Maandag 05 Februarie 2018** (voor die einde van die werksdag). SiVEST sal enige kommentaar wat na die openbare kommentaar en oorsigperiode ontvang word, direk aan die betrokke saakbeampte by die Departement van Omgewingsake (DEA) stuur.

Indien u enige vrae of navrae het, moet asseblief nie huiwer om ons te kontak by:

Stephan Jacobs / Hlengiwe Ntuli

Posbus 2921, Rivonia, 2128

Tel – (011) 798 0600

Faks – (011) 803 7272

E-pos – stephanj@sivest.co.za / hlengiwen@sivest.co.za

Vriendelike groete,

Kind Regards

Andrea Gibb

Senior Manager

SiVEST Environmental Division





SIVEST is a Level 3 BBBEE Contributor

Direct +27 11 798 0638 **Tel** +27 11 798 0600 **fax** +27 11 803 7272
email andreaq@sivest.co.za **website** www.sivest.co.za

Consulting Engineers - Project Managers - Environmental Consultants - Town and Regional Planners
Durban - Johannesburg - Pietermaritzburg - Richards Bay - Ladysmith - Cape Town - Harare (Zimbabwe)

Disclaimer

The information contained in this communication from the sender is confidential. It is intended solely for use by the recipient and others authorized to receive it. If you are not the recipient, you are hereby notified that any disclosure, copying, distribution or taking action in relation of the contents of this information is strictly prohibited and may be unlawful.

This email has been scanned for viruses and malware, and automatically archived by Mimecast SA (Pty) Ltd, an innovator in Software as a Service (SaaS) for business. Mimecast Unified Email Management ??? (UEM) offers email continuity, security, archiving and compliance with all current legislation. To find out more, [contact Mimecast](#).

Stephan Jacobs

From: Stephan Jacobs
Sent: Wednesday, March 7, 2018 1:49 PM
To: 'Stephnie Kot'
Cc: Andrea Gibb; 'rebecca.thomas@mainstreamrp.com'; Mary Waller; 'Elena Broughton'
Subject: RE: Comment on the Draft BAR: Proposed Substations and Power Lines for the Wind Farms near Loeriesfontein
Attachments: LEEUWBERG_GRID_OPTION_UTM34S_20180213.jpg;
31m_LEEUWBERG_GRID_ON_LOMBARD_AND_LINDTVELT_UTM34S_20180213.kmz; RE: 112081 Kokerboom 1 and 2 WEF - EIR available for public comment; FW: Reminder: Kokerboom 3 Draft Environmental Impact Report.; Response to BVI Objection_Socio-Economic_E Broughton.pdf

Importance: High

Tracking:	Recipient	Delivery
	'Stephnie Kot'	
	Andrea Gibb	Delivered: 3/7/2018 1:49 PM
	'rebecca.thomas@mainstreamrp.com'	
	Mary Waller	
	'Elena Broughton'	

Good day Stephnie,

I trust you are well.

The email and comment letter received on behalf of Business Venture Investments No. 1788 (Pty) Ltd (hereafter referred to as "BVI"), in response to the Draft Basic Assessment Reports (DBARs) for the proposed Graskoppies, Hartebeest Leegte, Ithemba and !Xha Boom 132kV Power lines and Substations, dated 5th of January 2018 refers.

- 1) BVI is the holder of Environmental Authorisations (EAs) for the Kokerboom 1 and Kokerboom 2 Wind Energy Facilities (WEFs) and has further applied to the Department of Environmental Affairs (DEA) for EA for the proposed Kokerboom 3 WEF. BVI have stated that each of the four (4) proposed power line corridor alternatives (i.e. Option 1, 2, 3 and 4) being proposed as part of the above-mentioned proposed Mainstream developments will traverse the Kokerboom WEFs, would come in close proximity to a number of turbines on the Kokerboom WEFs, and would also traverse other infrastructure associated with the Kokerboom WEFs (such as internal site roads and cabling). BVI have thus raised an objection to the proposed power line corridor alternatives and have suggested that a variation of the routing for Option 4 be considered by Mainstream. This variation in routing would allow for a sufficient setback distance to be maintained between the proposed power line and the turbines of the Kokerboom 3 WEF, which would suitably minimise the impact to this facility. BVI would thus offer no objection should Mainstream consider the variation to Option 4 as suggested.

Mainstream acknowledges that for Option 1, 2 and 3, based on a 240m setback, certain turbines of BVI's Kokerboom 1 and Kokerboom 2 WEFs would need to be moved to allow for the routing of the power line. Mainstream also acknowledges that the placement of turbines is done using a very sophisticated method of modelling, to determine the most optimal layout, for the greatest energy yield. Specific layouts have thus been proposed for the Kokerboom 1 and Kokerboom 2 WEFs and these facilities have subsequently received EAs based on these layouts. In light of the above, and also by taking the environmental findings and sensitivities into

consideration, power line corridor Option 1, 2 and 3 are considered less feasible and will therefore no longer be considered as preferred alternatives for the grid connection.

It should however be noted that based on a setback distance of 240m, Mainstream can still route the proposed power line within the assessed corridor for Option 4 without impacting on the turbines for the proposed Kokerboom 3 WEF. A map and KML file illustrating this has been attached to this email. Through this approach and by ensuring a setback distance of 240m, Mainstream can avoid impacting the proposed Kokerboom 3 WEF negatively. Mainstream is of the opinion the corridor assessed can suitably accommodate the alternative Option 4 as suggested in BVI's comment letter and there will be no need to present this as a 'new' alternative, but rather a preferred routing within Option 4. Therefore Option 4 will be presented as the preferred alternative in the FBAR.

Mainstream have continuously engaged with BVI with regards to this issue and are of the opinion that BVI's development rights have been considered. Furthermore, Mainstream is continuing to consider such rights, through actively ensuring a suitable alignment within the assessed corridor Option 4 will adhere to BVI's requirements.

- 2) BVI stated that the impacts to the economic viability of the Kokerboom Wind Farms and BVI's development rights have not been identified or assessed in the DBARs.

It should be noted that the Socio-Economic Specialist Assessment of the proposed power line corridor alternatives was undertaken in July in 2017, during which time the Environmental Impact Assessments (EIAs) for the proposed Kokerboom WEFs were still underway and the EAs had not been issued for these projects. No issues were raised by the adjacent developer during this time and therefore no negative Socio-Economic issues which would prevent the development of the proposed power line corridor alternatives were identified based on the information available at the time of the study. In addition, the positions of the proposed turbines were not finalised and available at this time, and therefore could not be considered in the Socio-Economic Assessment. Correspondence from Aurecon, the Environmental Assessment Practitioner (EAP) which was appointed by BVI to undertake the EIAs for the proposed Kokerboom WEFs, showing that that the Final Environmental Impact Assessment Reports (FEIARs) for the above-mentioned projects were only submitted in August and October 2017 respectively is attached to this email. It should also be noted that the specialist's studies and Basic Assessment Reports assessed the proposed power line corridors and not the exact locations of the power lines, and therefore the exact impact to the economic viability of the Kokerboom WEFs could not be completely determined at the time. However, through the public participation process and the comments received by BVI in this matter, Mainstream are confident that BVI's development rights are duly being considered, and will continue be considered as Mainstream aims to secure a grid line corridor with the least possible impact on the Kokerboom WEFs.

BVI have recommended a route that fits within power line corridor Option 4 and therefore SiVEST is of the opinion that the Socio-Economic findings and conclusions as previously assessed would remain unchanged. In addition, there are no negative socio-economic issues which would prevent the development of power line corridor Option 4, provided BVI's setback distances are adhered to during the design stages of the power line. This was subsequently confirmed by the Socio-Economic Specialist.

A letter which was provided by the Socio-Economic Specialist with regards to the issue above is attached to this email.

We trust that this sufficiently addresses the comments and objection raised by BVI with regards to the DBARs for the proposed Graskoppies, Hartebeest Leegte, Ithemba and !Xha Boom 132kV Power lines and Substations.

Mainstream trusts that the solution presented in this response is acceptable to BVI, and if not, is willing to engage further with BVI to ensure no rights are impacted.

Please do not hesitate to contact me should there be any issues or should you have any queries.

Kind Regards,

Stephan Jacobs (B.Sc.(Hons) Environmental Management and Analysis)

Environmental Consultant

SiVEST Environmental Division



SiVEST is a Level 3 BBBEE Contributor

Direct +27 11 798 0677 **Tel** +27 11 798 0600 **fax** +27 11 803 7272 **cell** +27 72 737 2114

email stephanj@sivest.co.za **website** www.sivest.co.za



Consulting Engineers - Project Managers - Environmental Consultants - Town and Regional Planners - Quality Management Consultants
Durban - Johannesburg - Pretoria - Pietermaritzburg - Richards Bay - Port Louis (Mauritius)

From: Stephnie Kot [mailto:stephnie.kot@aced.co.za]

Sent: Monday, February 5, 2018 5:02 PM

To: sivest_PPP; Stephan Jacobs

Cc: Andrea Gibb; 'rebecca.thomas@mainstreamrp.com'; Hlengiwe Ntuli; Mary Waller

Subject: RE: Comment on the Draft BAR: Proposed Substations and Power Lines for the Wind Farms near Loeriesfontein

Good day Stephan,

With reference to the below notification, please find attached comment submitted on behalf of Business Venture Investments No. 1788 (Pty) Ltd, in response to the draft Basic Assessment Reports for the proposed Graskoppies, Haartebeest Leegte, Ithemba and !Xha Boom 132kV Powerlines.

Please confirm receipt of the attached, and don't hesitate to contact me should you wish to discuss.

Thank you.

Kind Regards,

Stephnie Kot

o.b.o. Business Venture Investments No. 1788 (Pty) Ltd

Email: stephnie.kot@aced.co.za

Tel: 021 670 1423

Cell: 083 318 3982

From: sivest_PPP [mailto:sivest_ppp@sivest.co.za]

Sent: 14 December 2017 04:49 PM

Cc: Andrea Gibb <AndreaG@sivest.co.za>; Stephan Jacobs <StephanJ@sivest.co.za>;

'rebecca.thomas@mainstreamrp.com' <rebecca.thomas@mainstreamrp.com>; 'Nicolene Venter'

<nicolene@imaginativeafrica.co.za>

Subject: 13622 Proposed Substations and Power Lines for the Wind Farms near Loeriesfontein: DBAR Comment Period Starting

******* Please note that this email was sent from a NO REPLY email address. Please do not reply to this address as it is an unmonitored email account.*******

Dear Interested and/or Affected Party,

BASIC ASSESSMENTS (BAS) FOR THE PROPOSED DEVELOPMENT OF THE 132kV MAINSTREAM LINKING SUBSTATION AND FOUR (4) 132kV ON-SITE ESKOM SUBSTATIONS AND POWER LINES NEAR LOERIESFONTEIN, NORTHERN CAPE PROVINCE

- **132kV Graskoppies Substations and Power line**
– (DEA Ref No.: To be Announced)
- **132kV Hartebeest Leegte Substations and Power Line**
– (DEA Ref No.: To be Announced)
- **132kV Ithemba Substations and Power Line**
– (DEA Ref No.: To be Announced)
- **132kV !Xha Boom Substations and Power Line**
– (DEA Ref No.: To be Announced)

- **AVAILABILITY OF THE DRAFT BASIC ASSESSMENT REPORTS FOR PUBLIC REVIEW**

SiVEST is in the process of undertaking the Basic Assessments (BAs) for the proposed development of the above mentioned Substations and Power Lines near Loeriesfontein in the Northern Cape Province.

We would like to inform you that, in accordance with the National Environmental Management Act (NEMA) (as amended), the Draft Basic Assessment Reports (DBARs) for the above-mentioned projects will be made available for public review and comment as from **Thursday 14 December 2017** to **Monday 05 February 2018** (before end of business day). Hard copies of the DBARs are available at the following venue:

VENUE	STREET ADDRESS	HOURS	CONTACT NO
Loeriesfontein Library	Main Street, Loeriesfontein	Mondays – Fridays 14h00 – 17h00	027 662 8607

The reports as well as the accompanying appendices are also available on SiVEST's website: <http://www.sivest.co.za/>, click on downloads, then browse to the folder '13622 Mainstream Substations and Power Lines'.

Attached are English and Afrikaans letters notifying you of the availability of the reports, including Comment Forms.

We kindly request that you submit your comments to Public Participation Office at the below details, on or before **Monday 05 February 2018** (before end of business day). SiVEST will forward any comments received after the public comment and review period directly to the relevant case officer at the Department of Environmental Affairs (DEA).

Should you have any questions or queries please do not hesitate to contact us at:

Stephan Jacobs / Hlengiwe Ntuli

PO BOX 2921, Rivonia, 2128

Tel – (011) 798 0600

Fax – (011) 803 7272

Email – stephanj@sivest.co.za / hlengiwen@sivest.co.za

Kind Regards

ONDERWERP: 13622 Voorgestelde Substasies en Kraglyne vir doe Windplase naby Loeriesfontein: KBEV Kommentaar Periode Begin

Geagte Belangstellende en/of Geaffekteerde Party,

BASIESE EVALUERINGS (BE's) VIR DIE BEOOGDE ONTWIKKELING VAN DIE 132KV MAINSTREAM SKAKEL SUBSTASIE EN VIER (4) 132KV OP PERSEEL ESKOM SUBSTASIES EN KRAGLYNE NABY LOERIESFONTEIN, NOORD-KAAP PROVINSIE

- **132kV Graskoppies Substasies en Kraglyn**
– (DEA Verwysings No.: Moet nog aangekondig word)
- **132kV Hartbeest Leegte Substasies en Kraglyn**
– (DEA Verwysings No.: Moet nog aangekondig word)
- **132kV Ithemba Substasies en Kraglyn**
– DEA Verwysings No.: Moet nog aangekondig word)
- **132kV !Xha Boom Substasies en Kraglyn**
– DEA Verwysings No.: Moet nog aangekondig word)
- **BESKIKBAARHEID VAN DIE KONSEP BASIESE EVALUERINGSVERSLAE VIR OPENBARE OORSIG**

SiVEST is in die proses om die Basiese Evaluering (BE's) vir die voorgestelde ontwikkeling van die bogenoemde Substasies en Kraglyne naby Loeriesfontein in die Noord-Kaap Provinsie te onderneem.

Ons lig u graag hiermee in dat die Konsep Basiese Evalueringsverslae (KBEV's) vir die bogenoemde projekte, ooreenkomstig die Nasionale Wet op Omgewingsbestuur (NEMA) (soos gewysig), vanaf **Donderdag 14 Desember 2017** tot **Maandag 05 Februarie 2018** (voor die einde van die werksdag) beskikbaar gemaak sal wees vir openbare oorsig en kommentaar. Gedrukte kopieë van die KBEV's is beskikbaar by die plek wat hieronder genoem word:

PLEK	STRAATADRES	TYE	KONTAKNOMMER
Loeriesfontein Biblioteek	Mainstraat, Loeriesfontein	Maandae – Vrydae 14h00 – 17h00	027 662 8607

Die verslae sowel as die meegaande aanhangsels is ook beskikbaar op SiVEST se webwerf: <http://www.sivest.co.za>. Klik op 'Downloads' en soek dan vir die gids '13622 Mainstream Substations and Power Lines'.

Aangeheg is Engelse en Afrikaanse briewe wat u inlig oor die beskikbaarheid van die verslae, insluitende Kommentaarvorms.

Ons versoek u vriendelik om u kommentaar by die publieke deelnemende kantoor in te dien by die onderstaande besonderhede, voor of op **Maandag 05 Februarie 2018** (voor die einde van die werksdag). SiVEST sal enige kommentaar wat na die openbare kommentaar en oorsigperiode ontvang word, direk aan die betrokke saakbeampte by die Departement van Omgewingsake (DEA) stuur.

Indien u enige vrae of navrae het, moet asseblief nie huiwer om ons te kontak by:

Stephan Jacobs / Hlengiwe Ntuli

Posbus 2921, Rivonia, 2128

Tel – (011) 798 0600

Faks – (011) 803 7272

E-pos – stephanj@sivest.co.za / hlengiwen@sivest.co.za

Vriendelike groete,

Kind Regards

Andrea Gibb

Senior Manager

SiVEST Environmental Division





SIVEST



SIVEST is a Level 3 BBBEE Contributor

Direct +27 11 798 0638 **Tel** +27 11 798 0600 **fax** +27 11 803 7272
email andreag@sivest.co.za **website** www.sivest.co.za

Consulting Engineers - Project Managers - Environmental Consultants - Town and Regional Planners
Durban - Johannesburg - Pietermaritzburg - Richards Bay - Ladysmith - Cape Town - Harare (Zimbabwe)

Disclaimer

The information contained in this communication from the sender is confidential. It is intended solely for use by the recipient and others authorized to receive it. If you are not the recipient, you are hereby notified that any disclosure, copying, distribution or taking action in relation of the contents of this information is strictly prohibited and may be unlawful.

This email has been scanned for viruses and malware, and automatically archived by **Mimecast SA (Pty) Ltd**, an innovator in Software as a Service (SaaS) for business. **Mimecast Unified Email Management ??? (UEM)** offers email continuity, security, archiving and compliance with all current legislation. To find out more, [contact Mimecast](#).



Appendix 7D4
Correspondence
From IAPs

Land Owners:**1. Albie and Gene Louw , Hartebeest Leegte No 216****Farm size: 5100**

Used for commercial livestock (sheep) farming, extensive grazing. Type of sheep: Dorpers.

No-one currently resides on the property (it is a summer rainfall farm, sheep are moved there in summer)

Currently no workers employed on that particular farm. (1/2 worker temporarily employed for sheering on that farm, but permanently employed by owners)

Currently no workers live on that farm.

Currently no family members of workers live on that farm.

Monthly income per labourer is R3500.

Main income derived from sheep farming.

Average annual revenue from that farm: R500 000. (500 sheep x R1000)

Main concerns during construction phase:

- The farm is almost only grass, so not too worried about grass, it grows back quickly, but the destruction of the veld and shrubs are a concern because these do not recover fast and they are the primary source of
- During the building process sheep will have to be moved to another farm, which will be rented. There is not much farmland available for rent in the area.
- Water in the area is very scarce, so there is a worry about where water will be sourced from during the construction phase.

Main concerns post-construction/operational phase:

- Albie joked that the sheep will probably be happy to lie in the shade off the wind turbines
- Not concerned about visual impact, the turbines are beautiful
- Economic benefits for the farm and the town, there are more opportunities than before, there is more money in circulation, poverty has been slightly alleviated. After the wind farms break even (9 years), 5% of profits will go to the Loeriesfontein community. The community is already benefitting through increased employment figures, higher income and more spending power.
- There is a concern that the little town's population is increasing.
- There needs to be a grant for young mothers to support their children
- The government provided housing for 310 residents, they installed baths not showers, so during water restrictions, people fill their baths with water. This is problematic as there is not enough water.

2. Hein Burden, Portion 2 of Farm Georgs Vley No 127.

Farm size: +/-13000 ha (Georgs Vley plus neighbouring farms) George Vley is 3000ha

Used for commercial livestock (sheep) farming, extensive grazing. Type of Sheep: mainly Dorpers.

Hein, his wife and child permanently live on the farm. There are also (Hein rents the farms from his mother Marie M. Burden).

2 permanent workers living on the farm. One of which (long time employee) lives there with his wife and 2 children. The other worker's family live in Loeriesfontein, but he is still young without wife and children.

Temporary employment on the particular farm is 6 months, but his permanent employees do that work and then work on his other farms.

Monthly income per worker is R2400 for the newer worker, R3000 for the long-time employee. The employees also get free food and lodging.

Main income derived from sheep farming.

Average annual revenue from that farm: R1 400 000. (1400 units or sheep x R1000)

Main concerns during construction phase:

- Worried about the destruction of the bossie veld (shrubs) because these do not recover fast and they are the primary source of food for the sheep. Grass is not a problem as it recovers fast.
- Not worried of construction impacting the family and workers as the construction site is 14km from homestead/farm house.
- The construction company will have to discuss and agree on the path they will drive over the farm early on and stick to this to create minimal veld destruction.
- During the construction phase, 200 sheep will have to be moved to another farm, which will need to be rented. Compensation for this needed. There is a concern that there will be a shortage of available grazing land if all farmers will have to move their sheep.
- Water in the area is very scarce, so there is a worry about where water will be sourced from during the construction phase.
- No jobs would be lost during construction phase.
- Not concerned with other developments in the area as long as they do not affect his daily operations.
- Not sure where construction company gets water.
- Not concerned about construction workers. They prefer to live in town (Loeriesfontein), but will be concerned should anything happen to veld, water and sheep.
- Mainstream has tried to employ locals, but they prefer to "loaf". There is a lack of personal drive in many locals. This is a pity. Even little kids smoke tik.

Main concerns post-construction/operational phase:

- Hoped that maybe the wind turbines would scare away the jackals, as on average 200 sheep are lost to jackals per year.
- However, based on what other farmers have said, jackals quickly get used to the turbines.

3. Nico Louw.

Farm size: 5400 ha (Portion 2 of the Farm Graskoppies No 176)

Used for commercial livestock (sheep) farming, extensive grazing. Type of sheep: Meat Masters.

Family resides on the farm seasonally during summer rainfall time.

2 permanent workers who live on the farm. One of which lives there with his wife.

Monthly income per worker is R 3300, they also get some food (meat) and lodging.

Main income not derived from sheep farming, but date farming.

Average annual revenue from that farm: ranging between R90-R100 per ha (so close to R 500 000).
700 – 800 sheep on farm.

Main concerns during construction phase:

- Worried about criminal activities on the farm during construction phase (stock theft).
- The Sishen-Saldanha railway has increased stock theft by 100 fold.
- 50% fewer sheep will have to be moved from the farm in order to avoid the workers.
- Will have to rent other land during construction phase.
- No employment would be lost.
- Water is a problem in general in the area.

Other concerns or comments:

- Economic impact has been positive for Loeriesfontein based on other projects currently in progress.
- Gross profits have doubled and all businesses are doing much better.
- The dirt roads are actually also in much better condition. The tar road between Loeriesfontein and Nieuwoudtville is a bit worse. (I drove this road and it looked good)
- Social problems in town (Loeriesfontein) are very bad. The coloured women of the town provide “pleasures” to the construction workers who live on the town. It is becoming a norm. The same thing happened when French construction workers came to work on the Sishen-Saldanha railway. There were many pregnancies in those days and the offspring were and still are commonly referred to as ‘bastards’ – a term that is commonly used to describe descendants of European settlers and indigenous African women. (Though this term may sound discriminatory there is more complex history behind it and the ‘bastards’ proudly refer to themselves as such).
- There is a low standard of living for the coloured community in the town. Even though the town is better off economically, there is less work for the Loeriesfontein community, because of alcohol and drug abuse. (Tik).

4. Dr Nel (father of Hermanus Adriaan Nel)

Farm size: 5400 – 6000 ha (Remainder of farm Hartebeest Leegte No 216.)

Used for commercial livestock (sheep) farming, extensive grazing. Type of sheep: mainly Wit Dorpers, some Merinos.

Family does not reside on the farm, but rents out the farm and sheep to neighbour, Albie Louw.

Workers periodically live on farm during sheering season. However, as per the current rent agreement, Dr Nel employs no workers. All workers on the farm will be Albie's.

Main income is derived from the renting out sheep and land.

Average annual revenue from rental of this specific farm: R183 333

Main concerns during construction phase:

- Must be compensated for all operational losses during construction phase
- Losses will be proportionate to the rental income forfeited for the proportion of land (grazing surface) that is converted to road and construction site, or for all land that cannot be used for farming during construction phase. If Albie has to move sheep to another farm, then compensation for lost the rental income will be necessary.
- Construction company must ensure that minimal damage is done to the veld and that roads, etc. are set up as practically as possible, without infringing on existing infrastructure (fences, farm gates, water pipes, water installations, windmills, etc.).
- All proposed roads through the farm need to be discussed with and approved by Dr Nel before they are built.
- Care must be taken by construction workers not to do unnecessary damage to existing infrastructure and veld.
- Where operations interrupt farming, the construction company must take care to move water reservoir, fencing, wiring, feeding lot, etc., so that farming can continue with minimal interruption.
- Dust needs to be controlled as sheep, especially the Merinos, will be affected by this.

Grid and Neighbours

1. Koosie Nel (telephonic interview),

Farm size: 6000 ha (Portion 1 of the Farm Graskoppies No 176)

Used for commercial livestock (sheep) farming, extensive grazing. Type of sheep: Meat Masters.

Family resides on the farm seasonally during summer rainfall time (lives there on average 8 months a year)

1 permanent workers who lives on the farm his wife and children sometimes visit but live in Loeriesfontein.

Monthly income per worker is R 3000, and free lodging.

Main income is derived from sheep farming.

Average annual revenue from that farm: around R 500 000. 700 ewes on farm.

Main concerns during construction phase: Short term concerns

- Destruction of the veld. Grazing is food.
- Adequate compensation for loss of grazing area is a concern.
- Stock theft is a concern.
- Sheep would need to be moved during construction phase, other farmland will need to be rented.
- Construction company must keep farmers well informed of their plans, operations and movements. Keep them in the know and always get approval from farmers regarding where they plan to set things up.

Concerns post- construction: Long term

- Concern about power cables being set up in close proximity to the existing infrastructure: avoid dams, windmill, and preferably power cables should be far from main house.

2. Gert Johannes Lombard (father of Frans Lombard). “Gys & Margerite”

Farm size: 6621 ha (Portion 1 of 214 and Portion 1 of Konnes No 183 and Portion 8 of Dik Pens N 182)

Used for commercial livestock (sheep) farming, extensive grazing. Type of sheep: mainly Dorpers

Family resides on the farm seasonally during summer rainfall time.

2 permanent male workers who live on the farm. Their families sometimes visit, but live in Loeriesfontein.

Monthly income per worker is R 6000.

Main income is derived from sheep farming.

Average annual revenue from that farm: around R 600 000. 600 ewes on farm.

Main concerns during construction phase: (Short term concerns) See maps!

- Traffic and dust from passing construction vehicles is a big concern for **Portion 1 of the farm Konnes No 183**. The current road servicing the farm is frequented only by neighbouring farmers. It is a small quiet road that is not wide enough for two construction vehicles to drive side-by-side. The existing road directly passes the farm house (80m away) as well as the wind mill and the water reservoir which services all sheep on that farm. The road will have to be moved further away from farmstead as it will have a direct negative effect on the farming operations and the residents. Furthermore, re-routing the road will lead to destruction of veld, for which compensation will be necessary. The road’s re-routing must be done via prior consultation with the owner. The owner will also need to be adequately compensated for the operational changes he will have to make, which includes potentially moving the reservoir and windmill, re-arranging and thus re-fencing the existing sheep grazing areas. The road will have to be sprayed by **Ekit** to control the dust as it will severely impact the homestead and farming operations.
- Adequate compensation for loss of grazing area is a concern.
- Sheep would need to be moved during construction phase, other veld will need to be hired.
- Construction company must keep owner well informed of their plans, operations and movements. Keep them in the know and always get approval from owner regarding where they plan to set things up.

Concerns post- construction: (Long term) See maps!

- On **Rem of Aan Karree Doorn Pan No 213** and **Portion 1 of farm Karree Doorn Pan No 214** , there is an additional worry of power cables linking graspkoppies wind farm to Helios Substation going directly through these two farms. This would cause not only and short term, but a long term operational and infrastructural obstacle, as the power cables would be set up in close proximity to the existing infrastructure: dams, windmill, and preferably power cables should be far from main house.

Community Members:

1. Alwyn Muller, Lawyer, Loeriesfontein

What has been the economic and social impact of the Loeriesfontein/Khobab wind farms on the town? Economic benefit goes hand in hand with social decline.

- The social impact on the coloured community has been immense:
 - Drug and alcohol abuse have increased significantly.
 - There are 40 Polish workers on the Loeriesfontein wind farm site and they are a rough bunch. They pay the school girls.
 - There have so far been about 3 unwanted teenage pregnancies. School children are prostituting themselves.
 - Drug related crimes, and domestic violence have increased. The construction workers work hard and live hard.
 - The post-construction phase is worrying, because the workers will be left without jobs and there will be less income spent locally, so it would be beneficial to continue with more projects.
 - Littering has increased along the roads due to influx of people looking for jobs and a general lack of education on littering.
 - Casual labour should decrease but it has increased due to the fact that extensive farming is not labour intensive. Unemployment is a problem in Loeriesfontein and neighbouring towns, Calvinia and Brandvlei.

- Economic Impact has been immense too, but overall more positive for the local community:
 - The town has always been dependent on income from extensive farming and the farms are getting bigger in order to achieve economies of scale. An economic unit of farming is 5000 ha. But this farming is not at all labour intensive and if size of farm doubles, employment does not double, it stays about the same.
 - The salt and gypsum (salt and calcium) industries are the only other source of work in the area. 80% of the world's gypsum reserves lie just outside of Loeriesfontein. However, it only gets mined there, not processed. Gypsum mining is highly mechanised. A mine only employs about 10 workers. If a tax were placed on exporting raw gypsum to other provinces, more of it would be processed locally which would be a source of local jobs.
 - The salt pans at Dwaggas Pit currently employs around 30 permanent workers. If the government were to tax unprocessed goods leaving the province, more of the economic benefit would be felt locally. There is a salt packaging factory in the neighbouring town, Brandvlei that is employing local women. This should be an example of the job creation potential of local processing.
 - Furthermore, there is a date packaging business in Loeriesfontein itself. 1000 trees 50km outside of town. Packaging provides seasonal work for 40 women during packing season. Special packaging for export. This is a sustainable business, but need to look into more permanent employment.
 - Nieuwoudtville has a tea packaging factory that has led to increased employment.
 - About 80% of construction workers are from out of town, of these, about 80% prefer to stay in the town rather than on the construction site, they spend their income in the town, so they rent garages from locals.

- In Loeriesfontein, the informal hospitality industry is booming as a result of the construction workers needing accommodation in town. Everyone has made their garage and back yards available for rent. Hope to continue the boom via the tourism industry. Worrying though that when all the foreign workers leave there will be an oversupply of accommodation and a drop in income.
- Garage/fuel sales and grocery store sales have tripled.
- There has however also been an increase in liquor licences which is a real worry. There are about 10 licenced stores in the town.
- The Wind Mill Museum in Loeriesfontein is 20 years old and is the only one in the country. It has seen 4000 visitors in the last year. The new wind farms have also put Loeriesfontein on the map.
- There are many entrepreneurial activities. i.e. Taxis driving workers to the construction site, cleaning service, etc.
- Informal trading has increased, but this is a good thing for income and job creation.
- However, the only tar road out of town, linking Loeriesfontein and Nieuwoudtville is deteriorating rapidly due to increased heavy load traffic. It was tarred for low frequency traffic.
- 5% of wind farm revenue should go back to town, but not sure how this will be done practically.
- Potential project is Solar Capital photovoltaic solar energy project. 70MW has been approved, but no news on this yet.

2. Maria Husselman, owner of the local crèche looking after children from few months to 5 years. Linked to Early Childhood Resource Unit and Department of Social Development.

- Currently the crèche is running at full capacity, actually doesn't have enough capacity. 18 children, 2 mornings a week. Desperately need funding to expand.
- Provide stimulation and development to these children, offer a healthy snack (fruit, soup, mielie pap)
- There has been a massive decline in social development recently
- The Poles are not welcome here, their reputation with young girls preceded them
- They (the construction workers) impregnate the young girls, and then when the construction project is done they leave and the young girls are left with their babies
- The girls are looking for excitement and a party, so they go to the construction workers living in town, get free party, alcohol, drugs, they don't care what happens to them when in that state.
- The Poles don't like to stay on the construction site because the girls cannot visit them there
- Want to start a Centre for Drug and Alcohol Abuse, a remedial intervention and awareness centre. There is a dire need for it here. Need funding.

3. Hendrika Skeepers, domestic helper of Maria Husselman

- A minority of workers from Loeriesfontein are employed on the construction projects
- Hendrika's husband is employed on the construction project (the Loeriesfontein/Khobab Murray and Roberts project). He works on construction safety. Good workers are valued and trained.
- There are different phases of construction: working the terrain, foundations, wind poles (what is correct terminology?), wind blades, power cables. The Poles work on the power cables.
- But there were years where Loeriesfontein people were without employment, the wind projects have provided opportunities.
- The workers are tested for alcohol twice a week. If they have 3 positive tests for alcohol (breathalyser) they lose their jobs
- The local workers who lost their jobs went on strike in May 2016, they blocked the main road so no one could get in or out of town. Rocks were thrown at passing cars.
- The police riot unit were called in to stop the strike. They set off one stun grenade and the protesters dispersed in fear.
- Some of the local contract workers are angry with the poles and the black workers coming in from elsewhere and taking their jobs
- Spar is very expensive but there is no alternative, some people go to Vredendal to shop on weekends. There is a shuttle (I think Murray and Roberts provides this)
- Contract workers who have come in are an evil to the town, they bring their tablets, their cell phones and their "nice times", the young girls cannot resist
- Teen pregnancies are on the rise
- Even mothers with small children "rinkink", or are gallivanting, and neglect their own children
- There has been an increase in alcohol syndrome in babies
- And when the parents drink, their children follow suit, they have no guidance
- Even when parents are clean and have no alcohol problems it is very difficult to keep their children on the right track. Difficult to say no when there is peer pressure, and there is always temptation, it is constantly in your face. The workers are always flirting with the young girls.
- There is a tavern in the community area close to the sport field and their houses. This is where the workers hang out. It was a mistake to grant the liquor licence there.
- The poles and black men hang out there, and they have money, young people are so easily influenced. The poles have only been here 3 months but they already have a reputation. Their reputation preceded them.
- There was a white woman who petitioned that the Poles shouldn't come to the town before they even arrived, because of the reputation they had gained elsewhere.
- There are enough evils in the community, and now the town will never be the same.
- There are no social workers here, this is a dire concern.
- The drugs used include tik, dagga, mandrax.
- Children take them from as young as 9 years old.
- Hendrika's own son is in jail for drugs. And has been involved in domestic violence.
- The drugs are so bad, those whose use them reach a point where they lose themselves completely and there is no support from a social worker in town.
- Many children have to leave school at a young age because of drugs.
- Pocket money gets spent on drugs.

- There is too much stress in the community
- Really need a centre for drug and alcohol abuse, awareness, rehabilitation, and skills development
- The church pastor is very involved and also helps out at the school, but he cannot give enough individual attention (try speak to **Mnr Kotze of Church and Mr Jacques Klaaste** of School)
- These are the circumstances, but we are receiving no help to combat these ills
- We don't want to see our community like this

4. Victor Haupt, owner/founder of the Spar. (contact number: 071 246 2129)

- The construction brought in 40 young Poles, young men
- They earn lots of money, so what happens on weekends is there is nothing to do in the town (so they throw parties, invite the young girls, or the young girls com of their own volition)
- But the impact of the wind farms has been more positive than negative
- Can't expect there won't be negatives
- The social problems in this town come from a long time ago, it's nothing new, just happening on a bigger scale. What can one do?
- Form both sides, people are people. You cannot prevent it.
- Tiaan, the Spar store manager, is trying to employ locals, but then they get pregnant.
- The windfarms are a godsend, the money that has bene injected into the little town, into the school, the roads, has made a huge difference
- There has been no increase in crime/robberies, etc.
- The dirt road to the Loeriesfontein/Khobab site is constantly maintained, which is a good thing, but it would have been better just to tar it from the start, easier to maintain
- The increase in traffic between 5-7pm is actually nice, because things were so quiet here before
- The tar road to Nieuwoudtville needs to be maintained again, because of the heavy loads, but it is in better condition that it was a few years ago.
- The construction companies pay workers on a fortnightly or monthly basis (every 25th day of the month)
- There is not enough work in general, but at the moment, for every person that want to work, there is work. There are new opportunities.
- But the EFF was stirring trouble here just before the elections, initiating protest action amongst the coloured community, to demand higher wages. It disappeared after the elections.
- About 100-150 Loeriesfontein locals are employed on the wind project.
- A man was caught this morning with a big bag of dagga. It's a big problem, but it has always been a problem, it has just grown from a teaspoon of sugar to a bag of sugar.
- There are social problems, but they have always been there. The pub has a big screen. Sport attracts a party.
- In the post construction phase 5% of profits should go back to the town
- The town won't be what it was when the construction is over, but there are new projects coming so it's not yet a worry. And you can see the impact now already, the town is looking better, the walls have all been painted.
- Anyone who wants to can make an opportunity of it
- Everyone has water between 6-9pm, the water truck runs constantly between towns.
- 4 or 5 new boreholes are being constructed and will supply Loeriesfontein with water

Andrea Gibb

From: Stephnie Kot <stephnie.kot@aced.co.za>
Sent: Thursday, 17 November 2016 12:33 PM
To: Andrea Gibb
Cc: Stephan Jacobs
Subject: Request to Register as an I&AP: Leeuwerig Wind Farms & Grid Connections, Loeriesfontein, Northern Cape

Good day Andrea,

RE: REQUEST TO REGISTER AS AN INTERESTED & AFFECTED PARTY FOR THE EIAs FOR THE PROPOSED DEVELOPMENT OF FOUR LEEUWBERG WIND FARMS AND BASIC ASSESSMENTS FOR THE ASSOCIATED GRID CONNECTION NEAR LOERIESFONTEIN, NORTHERN CAPE PROVINCE

Kindly please register me as an Interest & Affected Party for the Environmental Impact Assessment processes to be undertaken for the four proposed Leeuwerig Wind Farms, and their associated grid connections (eight applications in total). Please register me as an I&AP for each of the eight applications:

- 140MW Graskoppies Wind Farm
- 140MW !Xha Boom Wind Farm
- 140MW Hartebeesleegte Wind Farm
- 140MW Itemba Wind Farm
- Graskoppies Grid Connection
- !Xha Boom Grid Connection
- Hartebeesleegte Grid Connection
- Itemba Grid Connection

My contact details are provided below:

Name: Stephnie Kot

Organisation: Infrastructure Asset Management (IAM)

Address: 2nd Floor Fernwood House, The Oval, 1 Oakdale Road, Newlands, 7700

Telephone Number: 021 670 1423

Email: stephnie.kot@aced.co.za

Interest: IAM is a renewable energy project developer with interests in the region, and would like to stay informed of the progress of the EIA for the proposed Leeuwerig Wind Farms and associated infrastructure.

Please acknowledge receipt of this request

Thank you.

Kind Regards,

Stephnie Kot

Project Manager – Renewable Energy Project Development

Email: stephnie.kot@aced.co.za

Tel: 021 670 1423

Cell: 083 318 3982

EIAs FOR THE PROPOSED DEVELOPMENT OF FOUR (4) WIND FARMS, AND BAs FOR THE ASSOCIATED GRID CONNECTION NEAR LOERIESFONTEIN, NORTHERN CAPE PROVINCE

Public Participation Office



Andrea Gibb / Stephan Jacobs
 SIVEST Environmental
 PO Box 2921, RIVONIA, 2128
 Tel (011) 798 0600
 Fax (011) 803 7272
 Email andrea@sivest.co.za /
 stephanj@sivest.co.za

REGISTRATION AND COMMENT FORM

Accompanying Background Information Document: February 2017

Please complete and return by post, fax or e-mail to the Public Participation Office (as above)

TITLE	Mr	FIRST NAME	SIPHELELE
INITIALS	S	SURNAME	DUNGA
ORGANISATION	BIO THERM ENERGY	EMAIL	sdunga@biothermenergy.com
POSTAL ADDRESS			
		POSTAL CODE	
TEL NO	011 3674600	FAX NO	011 367 4601

REGISTRATION AS INTERESTED AND/OR AFFECTED PARTY (I&AP) (please circle applicable box)

Please formally register me as an interested and affected party (I&AP) so that I may receive further information and notifications during the EIA and BA processes.	<input checked="" type="radio"/> YES	<input type="radio"/> NO
In terms of GNR 982 (2014 EIA regulations) I disclose below any direct business, financial, personal or other interest that I may have in the granting or rejection of the application for environmental authorisation (please use separate sheets if you wish):		
.....		
.....		

COMMENTS (please use separate sheets if you wish)

I suggest that the following issues of concern be investigated in the EIA / BA:

.....
 Authorised powerline routes for other projects near
 Loeriesfontein.

I suggest the following for the EIA / BA process and / or the public participation process:

.....

Any other comments:

.....

Please contact the following colleagues/friends to register as I&APs for this EIA / BA (name and contact details e.g. e-mail address):

.....

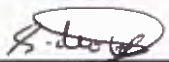

 Signature

THANK YOU FOR YOUR CONTRIBUTION

09 FEBRUARY 2017

 Date

OIE's VIR DIE BEOOGDE ONTWIKKELING VAN VIER (4) WINDPLASE
EN BE's VIR DIE GEPAARDGAANDE ROOSTERKONNEKSIE NABY
LOERIESFONTEIN, NOORD-KAAPPROVINSIE

REGISTRASIE- EN KOMMENTAARVORM

Vergesel Agtergrondinligtingsdokument: Februarie 2017

Openbare Deelnamekantoor

SIVEST

Andrea Gibb / Stephan Jacobs
SIVEST Environmental
Posbus 2921, RIVONIA, 2128
Tel: 011 798 0600
Faks: 011 803 7272
E-pos: andreag@sivest.co.za /
stephanj@sivest.co.za

Vul asseblief in en stuur dit per pos, faks of e-pos terug aan die Openbare Deelnamekantoor (soos hierbo).

TITEL	ME	VOORNAAM	JEANNETTE-ANNE
VOORLETTERS	J.E.	VAN	STEENKAMP
INSTANSIE	MUNISIPLIE RAAD	E-POS	janeystee@gmail.com
POSADRES	ANGELIER STRAAT 788, NIEUWOUTVILLE		
		POSKODE	8180
TEL. NO.	0722538788	FAKS NO.	

REGISTRASIE AS BELANGSTELLEDE EN/OF GEAFFEKTEERDE PARTY (B&GP) (omkring asb. die toepaslike blokkie)

Registreer my asseblief formeel as 'n belangstellende en geaffekteerde party (B&GP) sodat ek verdere inligting en kennisgewings tydens die OIE- en BE proses kan ontvang.

JA

NEE

Ingevolge Staatskennisgewing R982 (2014 OIE-regulasies) maak ek hieronder enige regstreekse sake, finansiële, persoonlike of ander belang wat ek kan hê in die goedkeuring of afkeuring van die aansoek om omgewingsmagtiging bekend (gebruik gerus aparte bladsye indien u wil):

KOMMENTAAR (gebruik gerus aparte bladsye indien u wil)

Ek stel voor dat die volgende knelpunte in die OIE / BE ondersoek word:

in Rehabilitasie of hervestigingsplan (Haalbaarheid)
- Verwydering van plant spesies in die beoogde areas voordat konstruksie begin. Dit ex-sita te groei (kweekery) = werkskepping weer te hervestig nadat konstruksie voltooi is.

Ek stel die volgende vir die OIE- / BE-proses en/of die openbare deelnameproses voor:

Voorkeur gee aan bewarings organisasies om saad, steggies en plante uit te haal voordat konstruksie begin, vir bewaringsdoeleindes (DENC; CAPE NATURE; SANBI; SANPARKS; MSA; CREW)
Enige ander kommentaar:

Tree asseblief in verbinding met my onderstaande kollegas/vriende om as B&GP's vir hierdie OIE / BE te register (naam en kontakbesonderhede, bv. e-posadres):

Eugene Marinus ; 076 234 2902 ; emmarinus@gmail.com

Janey Steenkamp
Handtekening

25/3/2017

Datum

DANKIE VIR U BYDRAE