



**Appendix 8**  
**EMPr**





**SOUTH AFRICA MAINSTREAM RENEWABLE POWER  
DEVELOPMENTS (PTY) LTD**

---

# **Proposed Construction of the !Xha Boom On-Site Eskom Substation, Linking Substation and Associated 132kV Power Line near Loeriesfontein, Northern Cape Province**

**Final Environmental Management  
Programme**

**DEA Ref No: 14/12/16/3/3/1/1870  
Issue Date: 19 March 2018  
Version No.: 1  
Project No.: 13622**

<b>Date:</b>	19 March 2018
<b>Document Title:</b>	Proposed Construction of the !Xha Boom On-Site Eskom Substation, Linking Substation and Associated 132kV Power Line near Loeriesfontein, Northern Cape Province: Final Environmental Management Programme
<b>Author:</b>	<b>Kerry Schwartz</b> BA (Geography), University of Leeds
<b>Version Number:</b>	1
<b>Checked by:</b>	<b>Andrea Gibb</b> B.Sc. (Hons) Environmental Management (UNISA) B.Sc. Landscape Architecture <i>Cum Laude</i> (UP)
<b>Approved:</b>	<b>Tarryn Curtis</b> B.Sc. Geographical Science (UK N) B.Sc. (Hons) Geography and Environmental Management (UK N)
<b>Signature:</b>	
<b>For:</b>	SiVEST Environmental Division

COPYRIGHT IS VESTED IN SIVEST IN TERMS OF THE COPYRIGHT ACT (ACT 98 OF 1978) AND NO USE OR REPRODUCTION OR DUPLICATION THEREOF MAY OCCUR WITHOUT THE WRITTEN CONSENT OF THE AUTHOR

**SOUTH AFRICA MAINSTREAM RENEWABLE POWER  
DEVELOPMENTS (PTY) LTD**

**PROPOSED CONSTRUCTION OF THE !XHA BOOM ON-SITE ESKOM  
SUBSTATION, LINKING SUBSTATION AND ASSOCIATED 132KV  
POWER LINE NEAR LOERIESFONTEIN, NORTHERN CAPE PROVINCE**

**FINAL ENVIRONMENTAL MANAGEMENT PROGRAMME**

<b>Contents</b>	<b>Page</b>
<b>1 INTRODUCTION .....</b>	<b>1</b>
<b>1.1 Details of the EAP .....</b>	<b>1</b>
<b>1.2 Site Locality and Description .....</b>	<b>2</b>
1.2.1 Regional Locality .....	2
1.2.2 Study Site Description .....	4
1.2.3 Climate .....	5
1.2.4 Sensitivity .....	5
<b>1.3 Overview of the proposed project .....</b>	<b>8</b>
<b>1.4 Specific Conditions Pertaining to Authorisations .....</b>	<b>10</b>
<b>1.5 Project Responsibilities .....</b>	<b>10</b>
1.5.1 The Project Company .....	10
1.5.2 Construction Team .....	11
1.5.3 Project Manager (PM) .....	12
1.5.4 Contractor Project Manager (CPM) .....	13
1.5.5 Main Contractor (MC) .....	13
1.5.6 Environmental Control Officer (ECO) .....	13
1.5.7 Environmental Officer (EO) .....	14
1.5.8 Community Liaison Officer .....	16
1.5.9 Responsible Parties and Auditing Process .....	17
1.5.10 Environmental Audits .....	21
<b>1.6 Layout of Environmental Management Programme .....</b>	<b>22</b>
1.6.1 Introduction .....	22
1.6.2 Pre-construction (Site establishment) .....	23
1.6.3 Construction .....	23
1.6.4 Operation .....	24
1.6.5 Decommissioning Phase .....	24
<b>1.7 Objectives of an EMPr .....</b>	<b>24</b>
1.7.1 Environmental Monitoring .....	25
<b>1.8 Applicable Legislation, Development Strategies and Guidelines .....</b>	<b>26</b>
1.8.1 The Equator Principles .....	26
<b>2 ENVIRONMENTAL DOCUMENTATION, REPORTING AND COMPLIANCE .....</b>	<b>3</b>
<b>2.1 Documentation .....</b>	<b>3</b>
2.1.1 Weekly Environmental Monitoring Report .....	3
2.1.2 Site Meetings .....	3
2.1.3 Method Statements .....	3
2.1.4 Communications Register .....	4

2.1.5	Photographic Record.....	5
2.1.6	Waste Manifests.....	5
2.1.7	Good Housekeeping.....	6
2.1.8	Management and Control.....	6
2.1.9	Recording and Reporting.....	6
2.1.10	Monitoring.....	6
<b>2.2</b>	<b>Compliance with the EMPr.....</b>	<b>7</b>
2.2.1	Non-Conformance Report.....	8
2.2.2	Environmental Emergency Response.....	9
2.2.3	Non-compliance.....	9
2.2.4	Training and Awareness.....	10
2.2.4.1	Training of Construction Workers.....	10
2.2.4.2	Contractor Performance.....	11
<b>3</b>	<b>MITIGATION GUIDELINES.....</b>	<b>12</b>
<b>3.1</b>	<b>Introduction.....</b>	<b>12</b>
<b>3.2</b>	<b>Pre-construction (Site Establishment).....</b>	<b>12</b>
<b>3.3</b>	<b>Pre-Construction Phase.....</b>	<b>13</b>
3.3.1	Site Preparation.....	13
3.3.2	Consultation.....	16
3.3.3	Site Clearing.....	17
<b>3.4</b>	<b>Construction Phase.....</b>	<b>18</b>
3.4.1	Construction Camp.....	18
3.4.2	Construction Traffic and Access.....	22
3.4.3	Environmental Education and Training.....	25
3.4.4	Soils and Geology.....	28
3.4.5	Erosion Control.....	31
3.4.6	Water Use and Quality.....	33
3.4.7	Surface and Groundwater.....	36
3.4.8	Waste Management.....	43
3.4.9	Flora.....	46
3.4.10	Fauna.....	50
3.4.11	Avifauna.....	52
3.4.12	Air Quality.....	53
3.4.13	Noise and Vibrations.....	55
3.4.14	Energy Use.....	59
3.4.15	Employment.....	59
3.4.16	Occupational Health and Safety.....	63
3.4.17	Security.....	69
3.4.18	Social Environment.....	70
3.4.19	Heritage.....	73
3.4.20	Visual Impact.....	76
<b>3.5</b>	<b>Operation Phase.....</b>	<b>78</b>
3.5.1	Construction Site Decommissioning.....	78
3.5.2	Rehabilitation and Maintenance.....	80
3.5.3	Operation and Maintenance.....	81
3.5.4	Avifauna.....	82
3.5.5	Air Quality.....	83
3.5.6	Biodiversity.....	84
3.5.7	Agriculture.....	87
3.5.8	Surface Water Resources.....	88
3.5.9	Health and Safety.....	89
3.5.10	Social Environment.....	90
3.5.11	Heritage.....	92
3.5.12	Visual Impact.....	92
<b>3.6</b>	<b>Decommissioning phase.....</b>	<b>94</b>

3.6.1	Ongoing Stakeholder involvement .....	94
3.6.2	Community health and safety .....	95
3.6.3	Waste Management .....	95
3.6.4	Agriculture .....	96
3.6.5	Surface and Groundwater .....	96
3.6.6	Biodiversity .....	97
3.6.7	Air quality .....	98
3.6.8	Visual Impact .....	99
<b>4</b>	<b>ADDITIONAL MANAGEMENT PLANS .....</b>	<b>101</b>
4.1	<b>Alien Invasive Management Plan .....</b>	<b>101</b>
4.2	<b>Plant Rescue and Protection Plan .....</b>	<b>102</b>
4.3	<b>Re-Vegetation and Habitat Rehabilitation Plan .....</b>	<b>103</b>
4.4	<b>Erosion Management Plan .....</b>	<b>104</b>
4.5	<b>Storm Water Management Plan .....</b>	<b>105</b>
4.6	<b>Open Space Management Plan .....</b>	<b>106</b>
4.7	<b>Monitoring System .....</b>	<b>107</b>
4.8	<b>Traffic Management Plan .....</b>	<b>109</b>
4.9	<b>Transportation Management Plan .....</b>	<b>110</b>
4.10	<b>Fire Management Plan .....</b>	<b>112</b>
4.10.1	Fire and Maintenance of Access Roads for Solar Facility .....	112
4.10.2	Fire Safety Act, 6 of 2002 .....	113
4.10.3	Principles of Fire Safety .....	113
4.10.4	Requirements in Terms of the South African Bureau of Standards (SABS) .....	113
4.10.5	Management Commitment .....	113
4.10.6	Employees' Contribution to Fire Management .....	114
4.10.7	Fire Prevention/Control .....	114
4.10.8	Response .....	114
4.10.9	Management Plan .....	115
4.11	<b>Environmental Awareness Plan .....</b>	<b>116</b>
4.11.1	Policy on Environmental Awareness .....	117
4.11.2	Implementation of Environmental Awareness .....	117
4.11.3	Training and awareness .....	117
4.11.4	Training of construction workers .....	118
<b>5</b>	<b>CONCLUSION .....</b>	<b>118</b>
5.1	<b>Pre-Construction Phase .....</b>	<b>119</b>
5.2	<b>Construction Phase .....</b>	<b>119</b>
5.3	<b>Operational Phase .....</b>	<b>119</b>
5.4	<b>Decommissioning Phase .....</b>	<b>119</b>

**List of Tables:**

<b>Table 1: Consultant Team .....</b>	<b>1</b>
<b>Table 2: Responsible Parties and Auditing Process .....</b>	<b>17</b>
<b>Table 3: Environmental Management Responsibilities .....</b>	<b>19</b>
<b>Table 4: Example of Procedure for Conducting Audits .....</b>	<b>21</b>
<b>Table 5: IFC Performance Standards .....</b>	<b>1</b>
<b>Table 6: Site preparation .....</b>	<b>13</b>
<b>Table 7: Consultation .....</b>	<b>16</b>
<b>Table 8: Site Clearing .....</b>	<b>17</b>

<b>Table 10: Construction Camp .....</b>	<b>18</b>
<b>Table 11: Construction Traffic and Access .....</b>	<b>22</b>
<b>Table 12: Environmental Education and Training .....</b>	<b>25</b>
<b>Table 13: Soils and Geology .....</b>	<b>28</b>
<b>Table 14: Erosion Control .....</b>	<b>31</b>
<b>Table 15: Water Use and Quality .....</b>	<b>33</b>
<b>Table 17: Surface and Groundwater .....</b>	<b>36</b>
<b>Table 18: Waste Management .....</b>	<b>43</b>
<b>Table 19: Flora .....</b>	<b>46</b>
<b>Table 20: Fauna .....</b>	<b>50</b>
<b>Table 21: Avifauna .....</b>	<b>52</b>
<b>Table 22: Air Quality .....</b>	<b>53</b>
<b>Table 23: Noise and Vibrations.....</b>	<b>55</b>
<b>Table 24: Energy use .....</b>	<b>59</b>
<b>Table 25: Employment .....</b>	<b>59</b>
<b>Table 26: Occupational Health and Safety .....</b>	<b>63</b>
<b>Table 27: Security .....</b>	<b>69</b>
<b>Table 28: Social Environment .....</b>	<b>70</b>
<b>Table 29: Heritage .....</b>	<b>73</b>
<b>Table 31: Visual Impact .....</b>	<b>76</b>
<b>Table 32: Construction Site Decommissioning .....</b>	<b>78</b>
<b>Table 33: Rehabilitation and Maintenance .....</b>	<b>80</b>
<b>Table 34: Operation and Maintenance .....</b>	<b>81</b>
<b>Table 35: Avifauna .....</b>	<b>82</b>
<b>Table 36: Air Quality .....</b>	<b>83</b>
<b>Table 37: Biodiversity .....</b>	<b>84</b>
<b>Table 38: Agriculture .....</b>	<b>87</b>
<b>Table 39: Surface Water Resources .....</b>	<b>88</b>
<b>Table 40: Health and Safety .....</b>	<b>89</b>
<b>Table 41: Social Environment .....</b>	<b>90</b>
<b>Table 42: Heritage .....</b>	<b>92</b>
<b>Table 43: Visual Impact .....</b>	<b>92</b>
<b>Table 44: Ongoing Stakeholder involvement .....</b>	<b>94</b>
<b>Table 45: Community health and safety .....</b>	<b>95</b>
<b>Table 46: Waste Management .....</b>	<b>95</b>
<b>Table 47: Agriculture .....</b>	<b>96</b>
<b>Table 48: Surface and Groundwater .....</b>	<b>96</b>
<b>Table 49: Biodiversity .....</b>	<b>97</b>
<b>Table 50: Air Pollution .....</b>	<b>98</b>
<b>Table 51: Visual Impact .....</b>	<b>99</b>
<b>Table 52: Alien Invasive Management Plan.....</b>	<b>101</b>
<b>Table 53: Plant Rescue and Protection Plan.....</b>	<b>102</b>
<b>Table 54: Re-Vegetation and Habitat Rehabilitation Plan .....</b>	<b>103</b>



<b>Table 55: Erosion Management Plan .....</b>	<b>104</b>
<b>Table 56: Open Space Management Plan .....</b>	<b>106</b>
<b>Table 57: Monitoring System .....</b>	<b>107</b>
<b>Table 58: Traffic Management Plan .....</b>	<b>109</b>
<b>Table 59: Transportation Management Plan .....</b>	<b>110</b>

**List of Figures**

<b>Figure 1: Regional Context Map .....</b>	<b>3</b>
<b>Figure 2: Route Overview Map .....</b>	<b>4</b>
<b>Figure 3: North-Western section of the preferred layout alternatives in relation to environmentally sensitive areas .....</b>	<b>6</b>
<b>Figure 4: North-Eastern section of the preferred layout alternatives in relation to environmentally sensitive areas .....</b>	<b>7</b>
<b>Figure 5: Southern section of the preferred layout alternatives in relation to environmentally sensitive areas .....</b>	<b>8</b>
<b>Figure 6: Preferred Layout Alternative .....</b>	<b>9</b>

**List of Annexures**

<b>Annexure A</b>	Environmental Incidents Register
<b>Annexure B</b>	Management of Soils Guidelines
<b>Annexure C</b>	Eskom Requirements for Work in or Near Eskom Servitudes
<b>Annexure D</b>	Heritage Management Guidelines and Plan

## **Glossary of Terms:**

**Construction Phase:** The activities pertaining to the preparation for and the physical construction of the proposed development.

**Contractor:** Persons/organisations contracted by the Project Company to carry out parts of the work for the proposed development.

**Decommissioning:** Means to take out of active service permanently or dismantle partly or wholly, or closure of a facility to the extent that it cannot be readily recommissioned.

**Engineer (E) / Project Manager (PM):** Person/ organisation appointed by the Project Company to oversee the work of all consultants, sub-developers, contractors, residents and visitors.

**Environmental Control Officer (ECO):** Person/organisation appointed by the Project Company who will provide direction to the Project Manager concerning the activities within the Construction one, and who will be responsible for conducting the environmental audit of the project during the construction phase of the project according to the provisions of the Environmental Management Programme.

**Environmental Management Programme (EMPr):** The EMPr is a detailed plan for the implementation of the mitigation measures to minimise negative environmental impacts during the life-cycle of a project. The EMP contributes to the preparation of the contract documentation by developing clauses to which the contractor must adhere for the protection of the environment. The EMPr specifies how the construction of the project is to be carried out and includes the actions required for the Post-Construction Phase to ensure that all the environmental impacts are managed for the duration of the project's life-cycle.

**Operational Phase (Post Construction):** The period following the Construction Phase, during which the proposed development will be operational.

**Pre-Construction Phase:** The period prior to commencement of the Construction Phase, during which various activities associated with the preparation for the Construction Phase will be undertaken.

**Rehabilitation:** Rehabilitation is defined as the return of a disturbed area to a state which approximates the state (where possible) which it was in before disruption. Rehabilitation for the purposes of this specification is aimed at post-reinstatement re-vegetation of a disturbed area and the insurance of a stable land surface. Re-vegetation should aim to accelerate the natural succession processes so that the plant community develops in the desired way, i.e. promote rapid vegetation establishment.

**Site Manager:** The person, representing the Contractor, responsible for all the Contractor's activities on the site including supervision of the construction staff and activities associated with the Construction Phase. The Site Manager will liaise with the Project Manager in order to ensure that the project is conducted in accordance with the Environmental Management Programme

## **Abbreviations:**

DEA	Department of Environmental Affairs
EA	Environmental Authorisation
EAP	Environmental Assessment Practitioner
ECO	Environmental Control Officer
EO	Environmental Officer
EHS	Environment, Health and Safety
EIA	Environmental Impact Assessment
ELO	Environmental Liaison Officer
EMPr	Environmental Management Programme
EP	Equator Principles
HOD	Head of Department
IFC	International Finance Corporation (World Bank Group)
I&APs	Interested and Affected Parties
MC	Main Contractor
MSDS	Material Safety Data Sheets
NEMA	National Environmental Management Act
OECD	Organisation for Economic Co-operation and Development
OHL	Overhead Line
PM	Project Manager
PS	Performance Standards
SAHRA	South African Heritage Resources Agency

# **SOUTH AFRICA MAINSTREAM RENEWABLE POWER DEVELOPMENTS (PTY) LTD**

## **PROPOSED CONSTRUCTION OF THE !XHA BOOM ON-SITE ESKOM SUBSTATION, LINKING SUBSTATION AND ASSOCIATED 132KV POWER LINE NEAR LOERIESFONTEIN, NORTHERN CAPE PROVINCE**

### **FINAL ENVIRONMENTAL MANAGEMENT PROGRAMME**

#### **1 INTRODUCTION**

South Africa Mainstream Renewable Power Developments (Pty) Ltd (hereafter referred to as 'Mainstream') are proposing to construct a 33kV/132kV on-site substation, namely the !Xha Boom On-Site Eskom Substation, a 132kV Linking Substation and an associated 132kV power line near Loeriesfontein in the Northern Cape Province (hereafter referred to as the 'proposed development'). The overall objective of the project is to feed electricity generated by Mainstream's proposed !Xha Boom Wind Farm (part of a separate on-going EIA process) into the national grid. SiVEST Environmental Division (hereafter referred to as 'SiVEST') has been appointed as the independent Environmental Assessment Practitioner (EAP) to undertake the Basic Assessment (BA) for the proposed development.

The proposed !Xha Boom On-Site Eskom Substation, Linking Substation and power line will connect the proposed !Xha Boom Wind Farm (part of a separate on-going EIA process) to the existing Eskom Helios Main Transmission Substation (MTS). As mentioned, the !Xha Boom Wind Farm is currently subject to a separate on-going Environmental Impact Assessment (EIA) process, the reference number for which is **14/12/16/3/3/2/1018**.

This Environmental Management Programme (EMPr) has been compiled in line with the recommendations in the above-mentioned EIA, as well as from issues identified by SiVEST. More details will be provided by the contractors and engineers once the detailed design has been completed.

#### **1.1 Details of the EAP**

As per the requirements of the NEMA (2014), the details and level of expertise of the persons who prepared the EMPr are provided in **Table 1** below.

**Table 1: Consultant Team**

<b>Environmental Practitioner</b>	SiVEST (Pty) Ltd – Andrea Gibb
<b>Contact Details</b>	<a href="mailto:andrea@sivest.co.za">andrea@sivest.co.za</a>
<b>Qualifications</b>	BSc Landscape Architecture and BSc (Hons) Environmental Management
<b>Expertise to carry out the EMPr</b>	<p>Andrea has 10 years' work experience and specialises in undertaking and managing Environmental Impact Assessments (EIAs) and Basic Assessment (BAs), primarily related to energy generation and electrical distribution projects. She also specialises in undertaking visual impact and landscape assessments, by making use of ArcGIS technology and field surveys. She has extensive experience in overseeing public participation and stakeholder engagement processes and has been involved in environmental baseline assessments, fatal flaw / feasibility assessments and environmental negative mapping / sensitivity analyses. From a business and administrative side, Andrea is actively involved in maintaining good client relationships, mentoring junior staff and maintaining financial performance of the projects she leads.</p> <p><b>Environmental Impact Assessments and Basic Assessments:</b></p> <ul style="list-style-type: none"> <li>▪ EIA for the proposed construction of a 75MW Solar Photovoltaic (PV) Power Plant near Dennenfontein, Limpopo Province.</li> <li>▪ EIA for the proposed development of the Dwarsrug Wind Farm near Loeriesfontein, Northern Cape Province.</li> <li>▪ BA for the proposed construction of two 132kV power lines and associated infrastructure from the Redstone Solar Thermal Power Project site to the Olien MTS near Lime Acres, Northern Cape Province.</li> <li>▪ BA for the proposed construction of two 132kV power lines and associated infrastructure from Silverstreams DS to the Olien MTS near Lime Acres, Northern Cape Province.</li> <li>▪ BA for the proposed Construction of the SSS1 5MW Solar Photovoltaic (PV) Plant on the Western Part of Portion 6 (Portion of Portion 5) of Farm Spes Bona 2355 near Bloemfontein, Free State Province.</li> <li>▪ BA for the proposed Construction of the SSS2 5MW Solar Photovoltaic (PV) Plant on the Eastern Part of Portion 6 (Portion of Portion 5) of Farm Spes Bona 2355 near Bloemfontein, Free State Province.</li> <li>▪ BA for the proposed Mookodi Integration Phase 2: Proposed Construction of a 132kV power line from the proposed Bophirima Substation to the existing Schweizer-Reneke Substation, North West Province.</li> <li>▪ BA for the proposed Mookodi Integration Phase 2: Proposed Construction of a 132kV power line from the Mookodi Substation to the existing Magopela Substation, North West Province.</li> <li>▪ BA for the proposed Mookodi Integration Phase 2: Proposed Construction</li> </ul>

	<p>of the Mookodi - Ganyesa 132kV power line, proposed Ganyesa Substation and Havelock LILO, North West Province.</p> <ul style="list-style-type: none"> <li>▪ Amendment of the Final Environmental Impact Report for the Proposed Mookodi 1 Integration Project near Vryburg, North West Province.</li> <li>▪ BA for the proposed 132kV power line and associated infrastructure for the proposed Redstone Solar Thermal Energy Plant near Lime Acres, Northern Cape Province.</li> <li>▪ BA for the proposed construction of a 132kV power line and substation associated with the 75MW Photovoltaic (PV) Plant on the Farm Droogfontein (PV 3) in Kimberley, Northern Cape Province.</li> <li>▪ BA for the proposed establishment of a Learning and Development Retreat and an Executive Staff and Client Lodge at Mogale's Gate, Gauteng Province.</li> <li>▪ Amendment application in order to increase the output of the proposed 40MW PV Facility on the farm Mierdam to 75MW, Northern Cape Province.</li> <li>▪ BA for the proposed construction of a power line and substation near Postmasburg, Northern Cape Province.</li> <li>▪ BA for the proposed West Rand Strengthening Project – 400kV double circuit power line and substation extension in the West Rand, Gauteng.</li> <li>▪ EIA for the proposed construction of a wind farm and PV plant near Prieska, Northern Cape Province.</li> <li>▪ Public Participation assistance as part of the EIA for the proposed Thyspunt Transmission Lines Integration Project – EIA for the proposed construction of 5 x 400kV transmission power lines between Thyspunt to Port Elizabeth, Eastern Cape Province.</li> <li>▪ EIA assistance for the proposed construction of three Solar Power Plants in the Northern Cape Province.</li> <li>▪ Public Participation as part of the EIA for the proposed Delareyville Kopela Power Line and Substation, North West Province.</li> <li>▪ Public Participation as part of the EIA for the Middelburg Water Reclamation Project, Mpumalanga Province.</li> </ul>
--	--

**1.2 Site Locality and Description**

*1.2.1 Regional Locality*

The proposed development will be located approximately 68km north of Loeriesfontein in the Northern Cape Province, within the Hantam Local Municipality (**Figure 1**)

The town of Loeriesfontein is within a basin surrounded by mountains, and is accessed from the N7 highway (north out of Cape Town), onto the R27 at Vanrhynsdorp, then following the R357 from Nieuwoudville to Loeriesfontein. Access to the study area is via the Granaatboskolk Road.

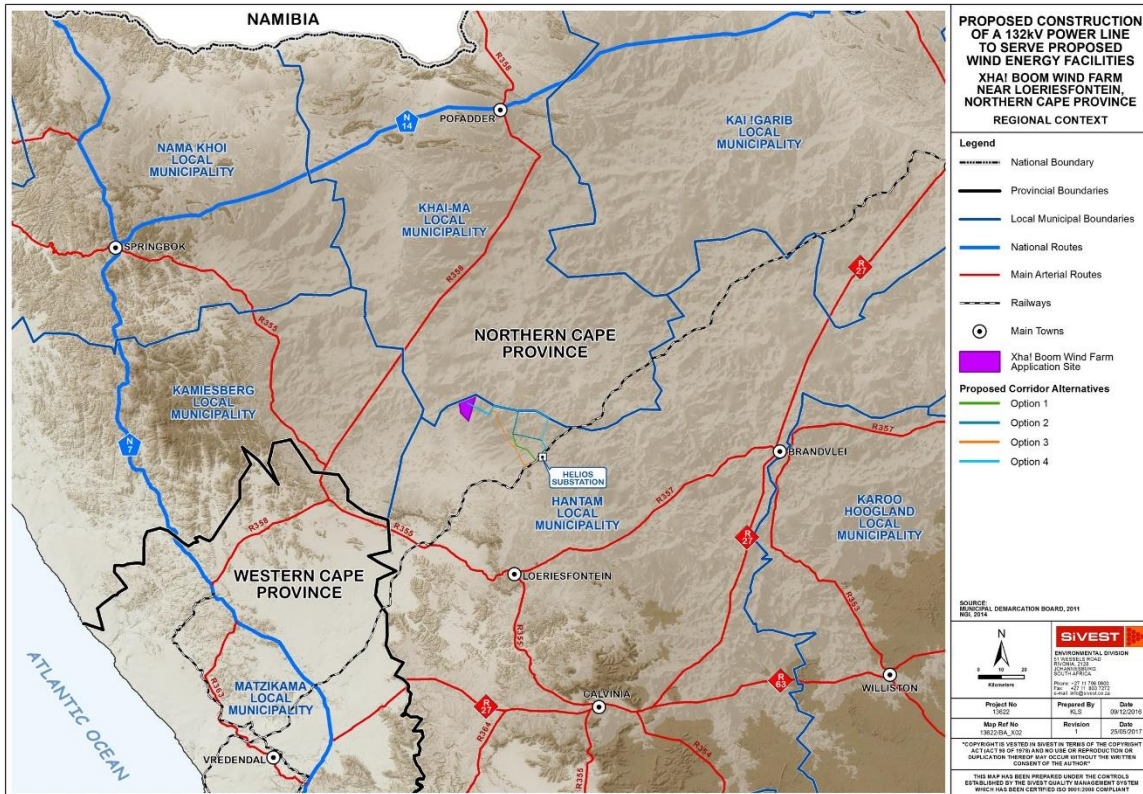
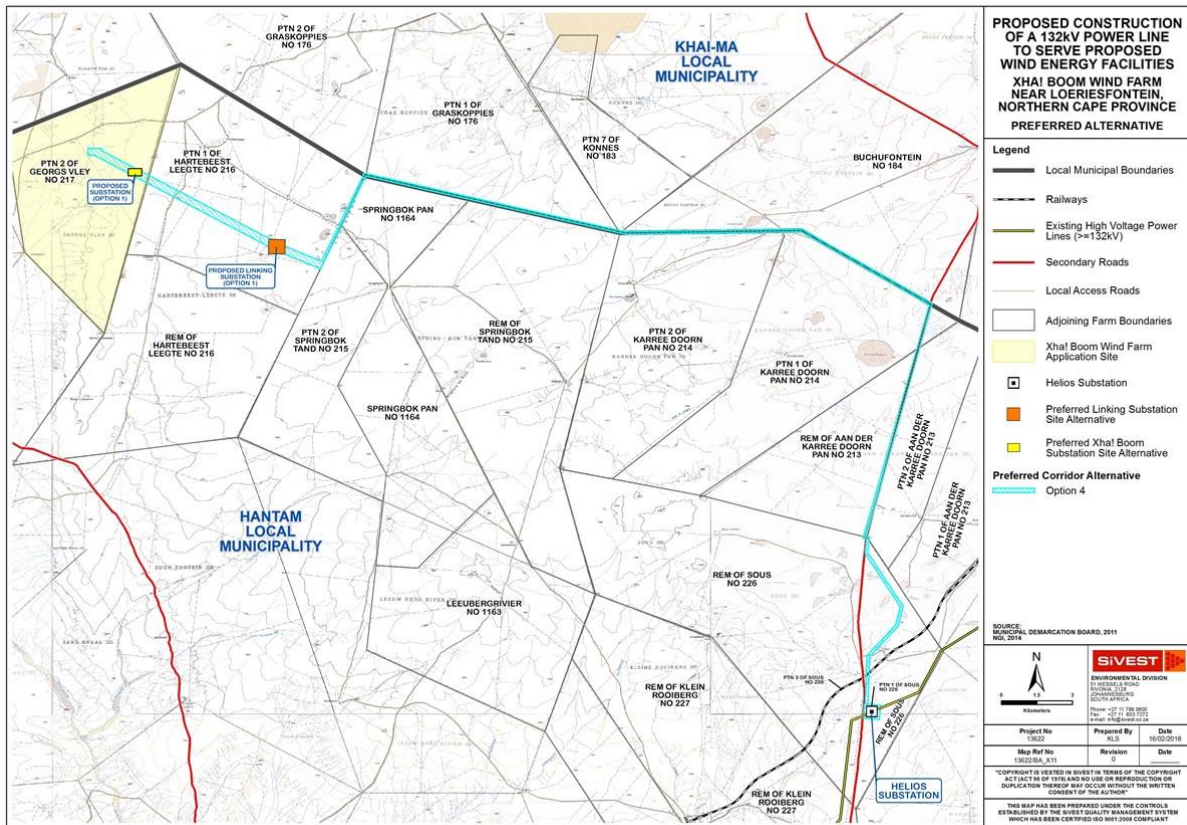

**Figure 1:** Regional Context Map

The proposed !Xha Boom On-site Eskom Substation will be located on Portion 2 of the Farm Georg's Vley No. 217, while the proposed Linking Substation will be located on Portion 1 of the Farm Hartebeest Leegte No. 216 (**Figure 2**). It should be noted that 132kV Power Line Corridor Option 4 has been selected as the preferred power line corridor alternative. The following farms will be traversed by the preferred 132kV power line corridor (i.e. Option 4):

- Portion 2 of the Farm Georg's Vley No. 217;
- Portion 1 of the Farm Hartebeest Leegte No. 216;
- Portion 2 of the Farm Springbok Tand No. 215;
- Portion 2 of the Farm Graskoppies No. 176;
- Portion 1 of the Farm Graskoppies No. 176;
- Remainder of the Farm Springbok Tand No. 215;
- Portion 7 of the Farm Konnes No. 183;
- The Farm Buchufontein No. 184;
- Portion 2 of the Farm Karree Doorn Pan No. 214;
- Portion 1 of the Farm Karree Doorn Pan No. 214;
- Portion 2 of the Farm Aan De Karree Doorn Pan No. 213;
- Remainder of the Farm Aan De Karree Doorn Pan No. 213;
- Portion 1 of the Farm Sous No. 226;

- Portion 3 of the Farm Sous No. 226; and
- Remainder of the Farm Sous No. 226.



**Figure 2:** Route Overview Map

### 1.2.2 Study Site Description

In terms of land cover, much of the area is classified as bare (non-vegetated) with some isolated patches of, low shrubland, thicket and woodland in evidence mainly in the south-eastern sector of the surrounding area. Sheep farming is the dominant activity in the area although the arid nature of the climate restricts stocking densities. As a result, farms in the area are relatively large and isolated farmsteads are scattered across the area resulting in a very low density of rural settlement. The area is therefore regarded as largely uninhabited and the natural vegetation has been retained across most of the surrounding area.

Limited human influence on the landscape is evident in the eastern section of the study area where small-scale mining/quarrying activities occur, mostly scattered along the Granaatboskolk Road and the railway line.



Built form and human influence on the landscape become more evident in the southern sector of the study area where several high voltage power lines feed into the Helios 400kV MTS Substation. Also present in this area are the the Khobab and Loeriesfontein Wind Farms which are presently under construction. Each of these developments includes some 61 wind turbines with associated infrastructure as well as 132kV grid connections to Helios Substation.

The topography across much of the area is characterised by a flat to gently undulating landscape with gentle slopes, typical of much of the Karoo. There are however areas of localised hilly topography characterised by the presence of small hills / ridges / koppies. In the wider area, the Klein and Groot Rooiberg and Leeuwberg koppies are significant features of the landscape, forming an area of localised hilly topography to the south and south-west of the proposed development.

The area is largely covered by the Bushmanland Basin Shrubland vegetation type, which is characterised by dwarf shrubland dominated by a mixture of low sturdy and spiny shrubs. Patches of Bushmanland Vloere occur in and around the salt pans scattered to the east of the proposed corridors, and is largely characterised by dwarf shrubs with loose thicket evident in some areas.

### 1.2.3 *Climate*

The climate of the study area (Monnik & Malherbe, 2005) can be regarded as warm to hot with occasional rain in summer and dry winters. The long-term average annual rainfall in this region of the Northern Cape is only 198 mm, of which 138 mm, or 69%, falls from November to April. Rainfall is erratic, both locally and seasonally and therefore cannot be relied on for agricultural practices. The average evaporation is over 2 100 mm per year, peaking at over 8.5 mm per day in December.

Temperatures vary from an average monthly maximum and minimum of 31.6 C and 11.8 C for January to 15.9 C and 1.0oC for July respectively. The extreme high temperature that has been recorded is over 42 C and the extreme low –10.0 C. Frost occurs most years on 30-40 days on average between early May and mid-September.

### 1.2.4 *Sensitivity*

Several specialist studies were conducted during the BA process to identify issues or legislative implications associated with the proposed development. These include:

- Biodiversity Assessment (fauna and flora);
- Avifauna Assessment;
- Surface Water Assessment;
- Soils and Agricultural Potential Assessment;
- Heritage Assessment;
- Palaeontology Assessment (Desktop);
- Visual Assessment; and

- Socio-Economic Assessment.

Based on the various specialist studies which were conducted, a few potentially sensitive sites have been identified within the study area. These informed the assessment of alternatives.

The preferred substation sites and power line corridor alternatives in relation to environmentally sensitive areas are indicated in **Figure 3** to **Figure 5** below.

It should be noted that the preferred substation sites and power line corridor layout alternatives in relation to environmentally sensitive have been provided in sections (i.e. North-West, North-East and South). This was done in order to clearly show all identified environmentally sensitive areas affected by the preferred layout alternatives and identified in various sections of the preferred power line corridor.

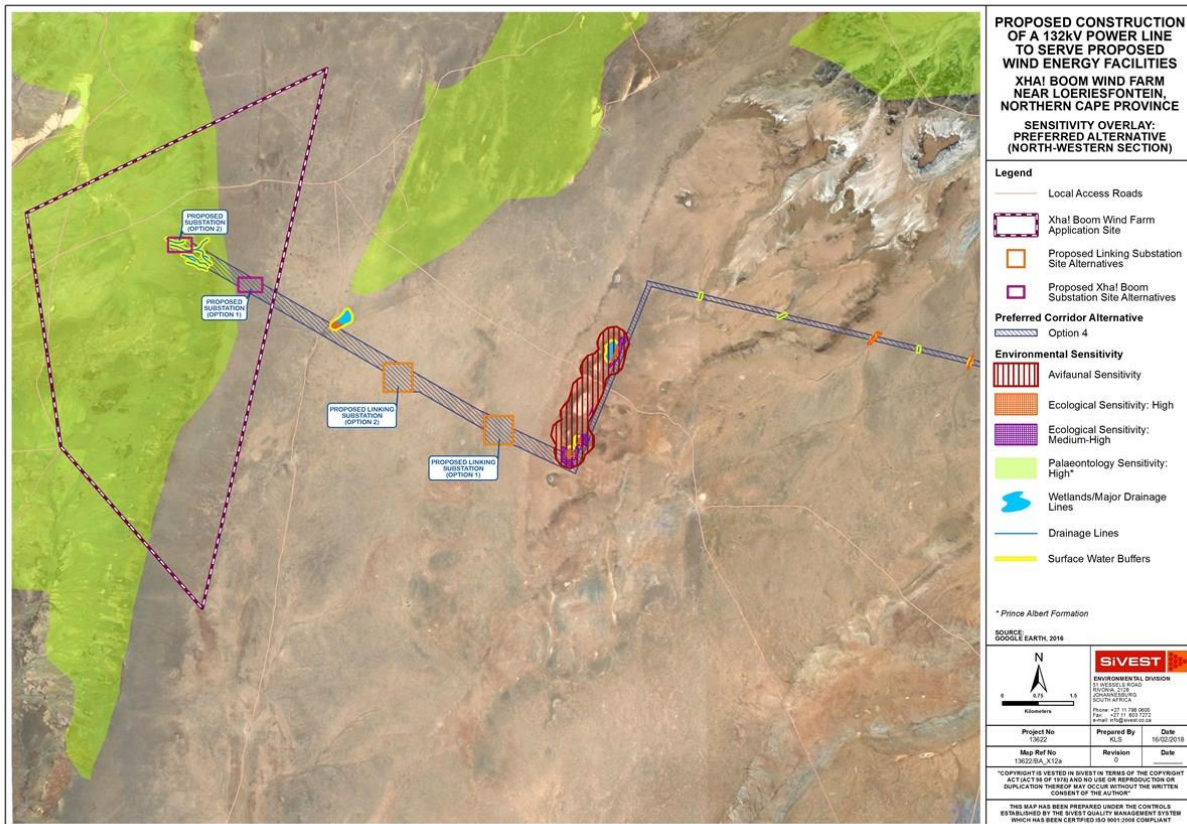

**Figure 3:** North-Western section of the preferred layout alternatives in relation to environmentally sensitive areas

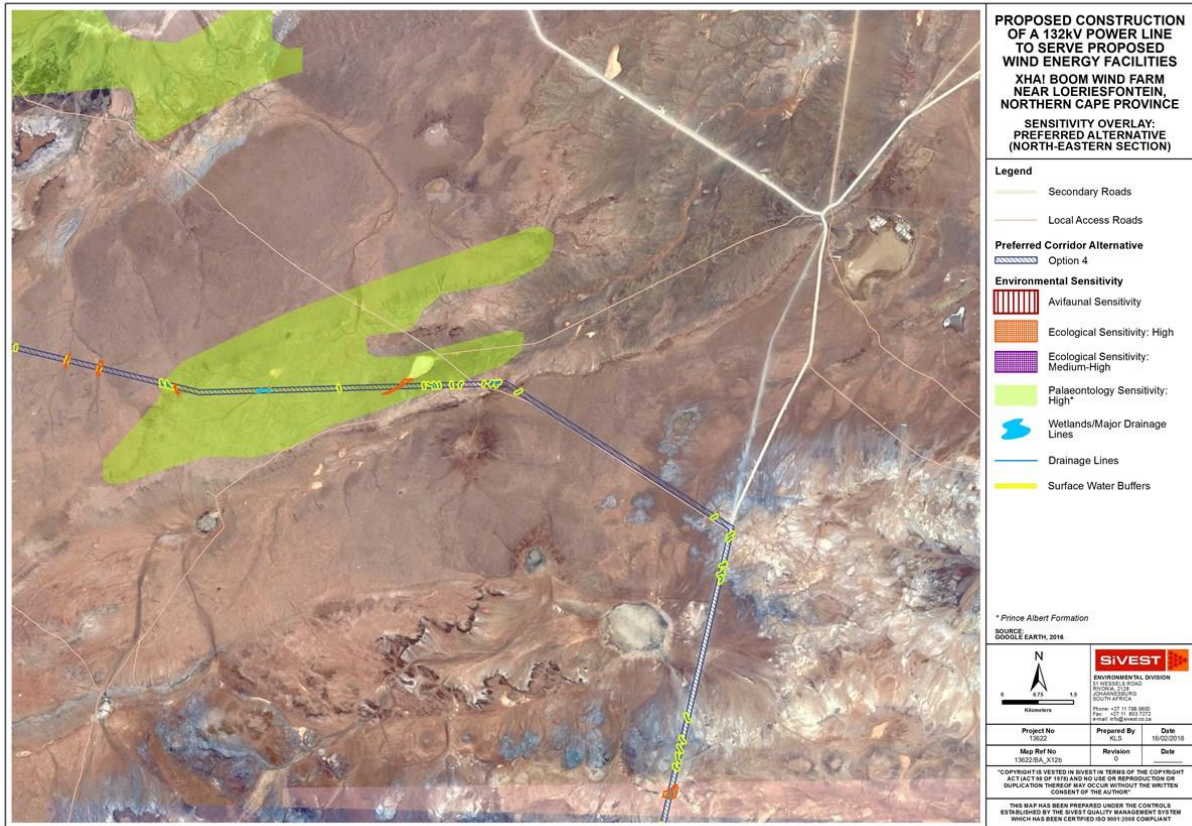

**Figure 4:** North-Eastern section of the preferred layout alternatives in relation to environmentally sensitive areas

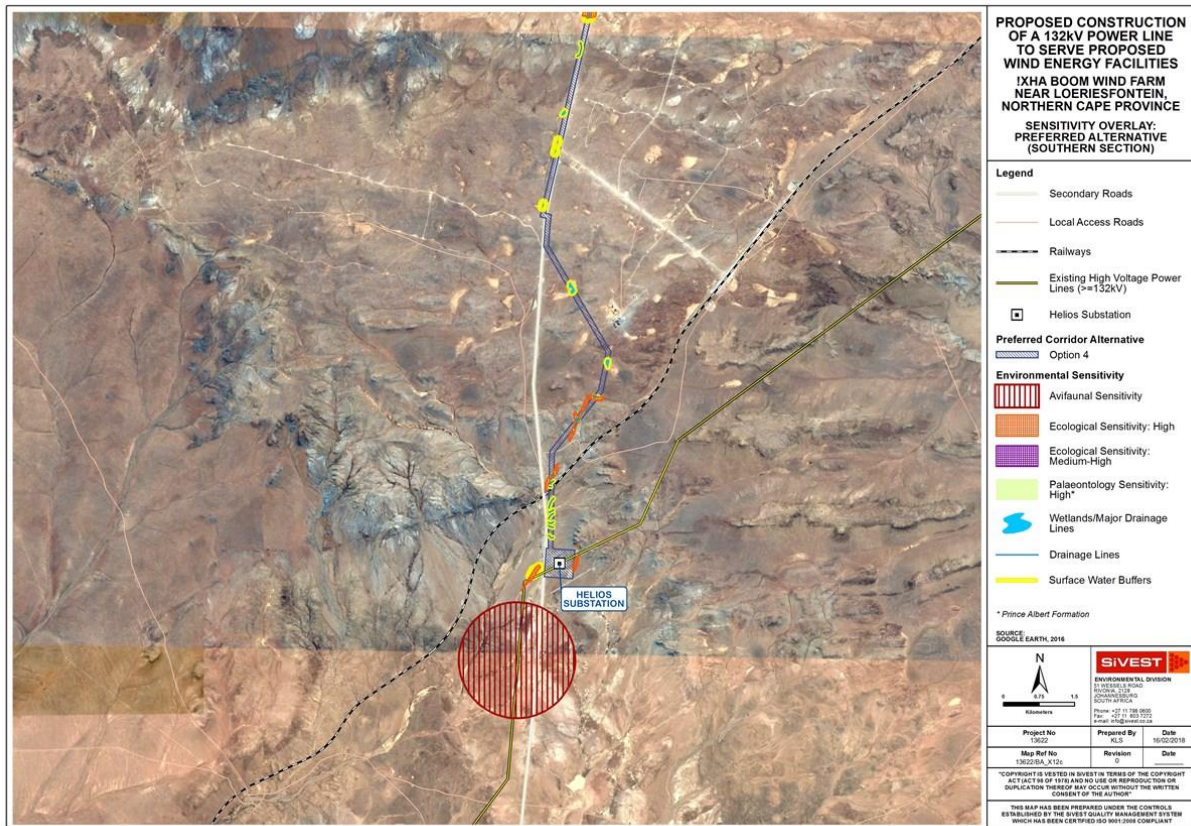

**Figure 5:** Southern section of the preferred layout alternatives in relation to environmentally sensitive areas

### 1.3 Overview of the proposed project

The proposed development will encompass the construction of an On-site Eskom Substation (namely the !Xha Boom Substation), Linking Substation and associated power line in order to feed electricity generated by the proposed !Xha Boom Wind Farm (part of a separate on-going EIA process) into the Eskom grid. The proposed !Xha Boom Substation, Linking Substation and associated power line will have voltage capacities of up to 132kV respectively. The proposed power line will run from the !Xha Boom Substation to the existing Helios MTS and will have a servitude width of approximately 31m. The proposed power line will consist of a series of towers located approximately 170m to 250m apart, depending on the terrain. At this stage, the type of towers being considered for the proposed power line include 132kV Twin Tern Double Circuit towers. The proposed tower type is between 20m and 24m in height, depending on the terrain, but will be high enough to ensure minimum overhead line clearances from buildings and surrounding infrastructure. It should be noted that the exact height and location of the towers will be determined and confirmed during the final design stages of the power line.

Access roads to the !Xha Boom Substation and Linking Substation will form part of the associated components / infrastructure. It should be noted that for the purpose of the BA, Mainstream assessed areas

of approximately 15ha and 36ha for the proposed !Xha Boom On-site Eskom Substation and Linking Substation sites respectively. However, only areas of approximately 7.5ha and 3ha will be used for the construction of the proposed substations respectively. In addition, an area of approximately 124ha will be cleared for the proposed power line servitude. Ultimately, an area of approximately 134.5ha is expected to be cleared for the entire proposed development. The final design details are yet to be confirmed and will become available during the detailed design phase of the project. In addition, the length of the proposed preferred power line corridor (i.e. Option 4) is approximately 53.4km

The preferred alternatives as provided in **Figure 6** below, are as follows:

- !Xha Boom Substation Site Location Option 1: Approximately 7.5 hectares
- Linking Substation Site Location Option 1: Approximately 3 hectares
- Power line Corridor Option 4: Approximately 53.4kms in length

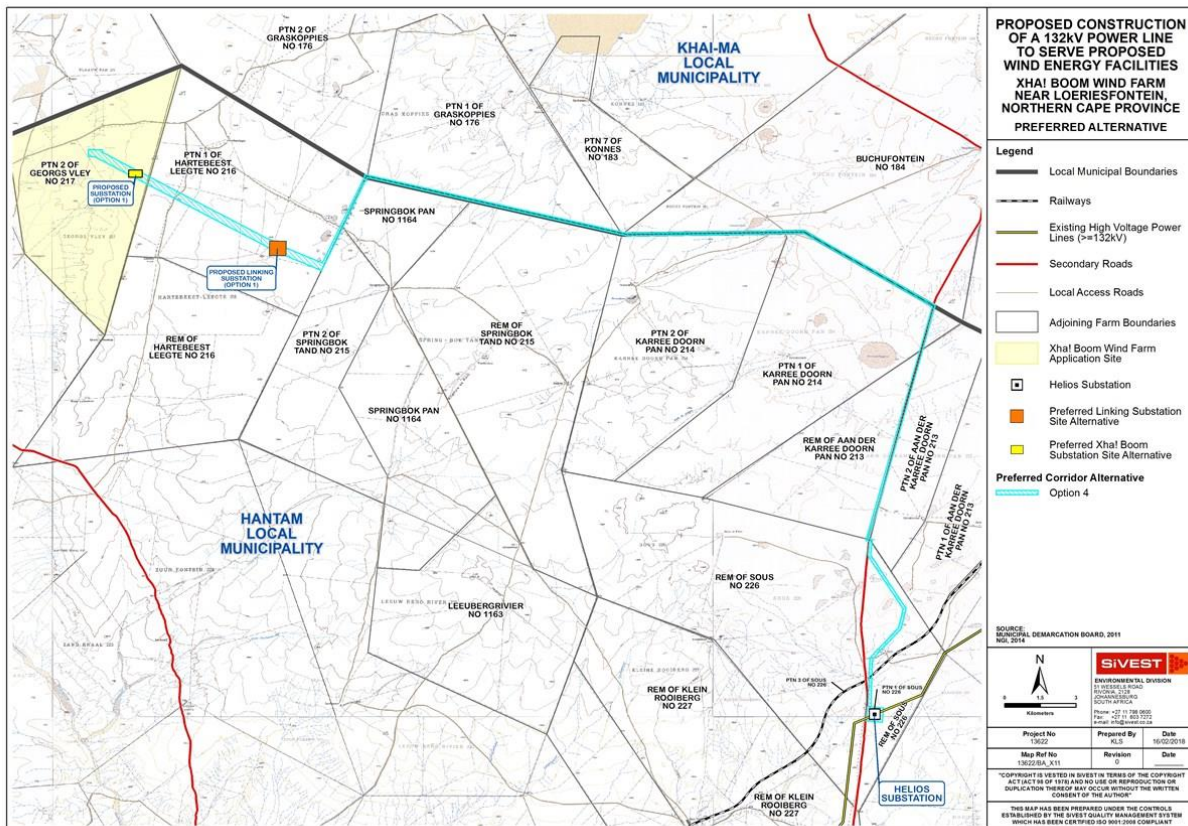

**Figure 6:** Preferred Layout Alternative

Other associated infrastructure includes the following:

- Internal access roads to the substation and power line corridor. Internal access roads with a maximum width of 20m are initially being proposed for the construction phase. This is however only temporary as the width of proposed internal access roads will be reduced to approximately 6m -

8m for maintenance purposes during the operational phase. The proposed internal access roads will include the net load carrying surface excluding any V drains that might be required.

As previously mentioned, the proposed On-site Eskom Substation and Linking Substation will be shared substations connecting the !Xha Boom Wind Farm (part of a separate on-going EIA process) to Eskom's existing Helios MTS. The above-mentioned wind farm will however require a separate Environmental Authorisation (EA) and therefore the EIA has been conducted separately. The DEA reference number allocated for the proposed !Xha Boom Wind Farm is **14/12/16/3/3/2/1018**.

## **1.4 Specific Conditions Pertaining to Authorisations**

Should the Department of Environmental Affairs (DEA) issue an EA for the proposed project, this EMPr will be updated to include all the pre-construction, construction, operation and decommissioning conditions stipulated in the EA.

Specific conditions pertaining to regulatory processes, or Licensee / Holder of the Authorisation requirements, have not been included within the EMPr. These conditions are to be undertaken by the Licensee / Holder of the Authorisation prior to the commencement of construction related activities.

## **1.5 Project Responsibilities**

The roles and responsibilities of all the key role players involved in the EMPr are represented below.

### *1.5.1 The Project Company*

The Project Company will be responsible for the overall control of the project site in environmental terms during the pre-construction, construction, operation, decommissioning and rehabilitation phases of the proposed project. These responsibilities include the following:

- Appointing an independent ECO for the duration of the construction phase of the project and notifying the DEA of their contact details;
- Being fully familiar with the BA Report, EA conditions and the EMPr;
- Notifying the DEA of changes in the developments that result in significant environmental impacts;
- Notifying the DEA within 30 days of change of ownership;
- Notifying the DEA of any change of address of the owner/Project Company;
- The overall implementation of the EMPr;
- Ensuring compliance, by all parties, and the imposition of penalties for non-compliance
- Implementing corrective and preventive actions, where required;
- Preventing pollution and actions that will harm or may cause harm to the environment;

- Ensuring the activity does not commence within 30 days of the EA being issued;
- Notifying the DEA within 30 days that construction activity will commence;
- Notifying the DEA in writing within 24 hours if any condition in the EA cannot be or is not adhered to;  
and
- Notifying the DEA 14 days prior to commencement of the operational phase.

### 1.5.2 Construction Team

Several professionals will form part of the construction team. The most important from an environmental perspective are the Project Manager (PM), the Contractor Project Manager (CPM), the Main Contractor (MC), the Environmental Control Officer (ECO), the Environmental Officer (EO) and the Community Liaison Officer (CLO).

The PM is responsible for the implementation of the EMPr on the site during the pre-construction and construction phases of the project.

The CPM is responsible for the establishment and management of contracts for the Main Contractor and the Sub-contractors.

The MC is responsible for abiding by the mitigation measures of the EMPr which are implemented by the Project Manager during the construction phase.

The MC is also responsible for the implementation of the EMPr during the operational and decommissioning phases of the project. However, it must be noted that the MC may change for each phase of the project. The EMPr will therefore be applicable to the relevant MC appointed for each phase of the project.

The ECO is responsible for monitoring the implementation of the EMPr during the design, pre-construction and construction phases of the project.

The EO is responsible for managing the daily onsite implementation of the EMPr.

The CLO is responsible for managing the daily on-site implementation of the social aspects of the EMPr.

### Basic Organogram:

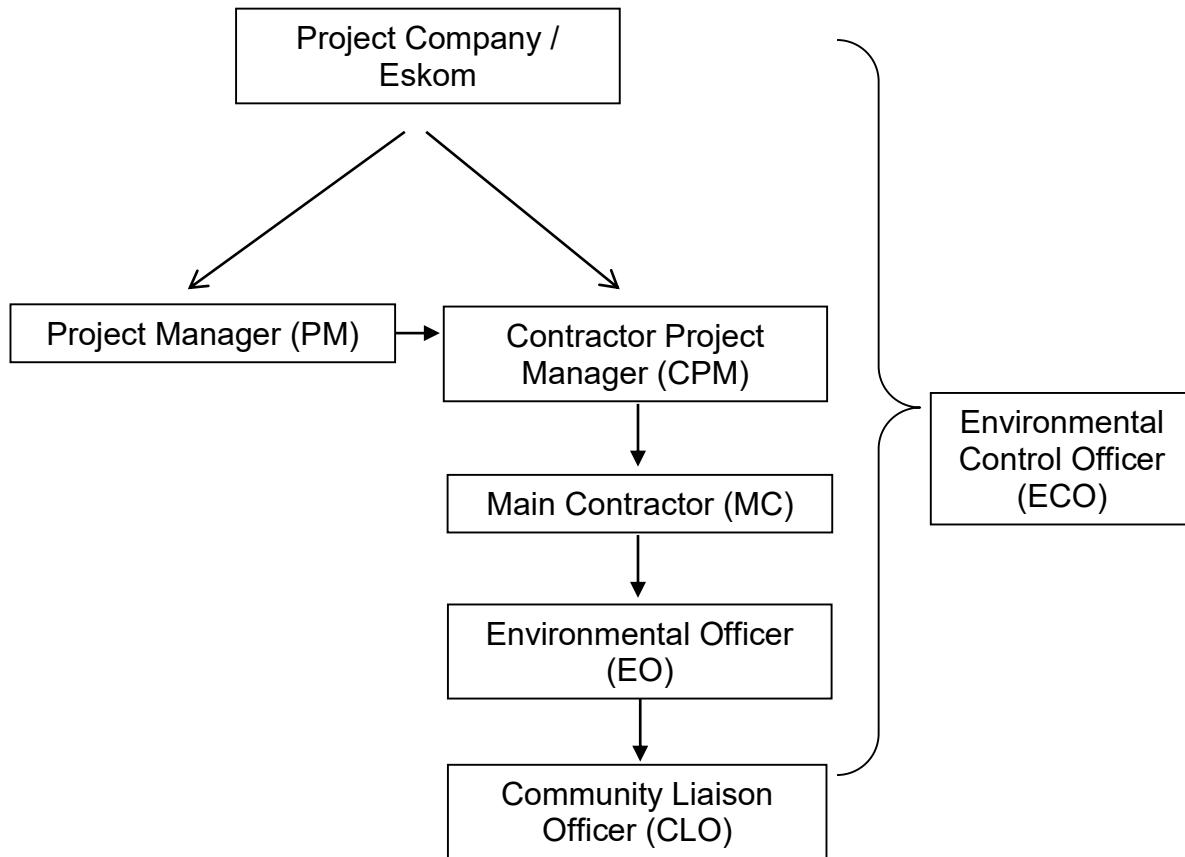

#### 1.5.3 Project Manager (PM)

The PM is responsible for overall construction management of the project as well as the implementation of the EMP. The following tasks will fall within his / her responsibilities:

- Be aware of the findings and conclusions of the BA and the conditions stated within the EAs;
- Be familiar with the recommendations and mitigation measures of this EMP, and implement these measures;
- Monitor site activities on a daily basis for compliance;
- Confine the construction site to the demarcated area; and
- Rectify transgressions through the implementation of corrective action.

The Project Manager will assume ultimate responsibility. However, the abovementioned tasks can be delegated to the on-site manager for daily management.



#### 1.5.4 Contractor Project Manager (CPM)

The CPM will undertake overall project contracts management between of the Main Contractor and the appointed Sub-Contractors. The following tasks will fall within his / her responsibilities:

- Responsible for establishing contractual agreements with the Main Contractor and Sub-Contractors, and ensuring that sub-contractors adhere to the EMPr

#### 1.5.5 Main Contractor (MC)

The MC is responsible for the implementation and compliance with recommendations and conditions set out in the EMPr. This requires that the MC be familiar with the BA report, EA conditions and the EMPr. This encompasses the following activities:

- Ensuring compliance with the EMPr at all times during construction;
  - Ensuring that all subcontractors have a copy of and understand the contents of the EMPr, to ensure environmental best practice.
- Preventing pollution and avoid actions that will impact or harm the surrounding environment;
- Responsible for the construction activities to be carried out for the duration of the project (with subcontractors and contract workers);
- Implementing corrective and preventive actions, where required;
- Maintain an environmental register which keeps a record of all incidents which occur on the site during construction. These incidents include:
  - Public involvement / complaints;
  - Health and safety incidents;
  - Hazardous materials stored on site; and
  - Non-compliance incidents.
- Development of specific method statements prior to commencement of environmentally sensitive constructions activities as identified in the EMPr.

#### 1.5.6 Environmental Control Officer (ECO)

The ECO is responsible for the implementation of the EMPr during the construction phase and liaison between the Contractor and the Landowners. The ECO should have a relevant environmental degree or relevant tertiary qualification. The ECO is also to be an independent party. The ECO will liaise and report to the Contractor and authorities, thus the ECO should have effective communication and negotiating skills. The following tasks will fall within his / her responsibilities:

- Be aware of the findings and conclusions of the Basic Assessment and the conditions stated within the EAs.
- Work with the construction team to review relevant risk/ method statements from an environmental perspective;
- Be familiar with the recommendations and mitigation measures of this EMPr;
- Conduct monthly audits of the construction site according to the EMPr and EAs. A monthly report will be produced detailing the findings of the audit highlighting any non-compliance issues. Positive compliance with the EMPr will also be noted;
- Educate the construction team about the management measures of the EMPr and EAs.
- Regular liaison with the construction team and the project leader;
- Recommend corrective action for any environmental non-compliance incidents on the construction site;
- The affected parties must always be kept informed about any changes to the construction programme should they be involved. If the ECO is not on site the Contractor should keep the affected parties informed. The contact numbers of the Contractor and the ECO must be made available to the affected parties. This will ensure open channels of communication and prompt response to queries and claims; and
- Liaising with the heritage specialist in the case of unearthing of artefacts and/ or graves.

The ECO is responsible for providing an independent evaluation of compliance with the EMPr and not for enforcement of conditions of the EMPr. The Project Company is responsible for enforcement of the conditions of the EMPr.

The Contractor and the EO are accountable to the ECO for non-compliance with the EMPr. The ECO provides feedback to the Project Company and I&APs, as required. Issues of non-compliance raised by the ECO must be taken up by the Project Company's Representative and resolved with the Contractor as per the conditions of his/her contract.

The ECO will remain employed for the full duration of the contract until all snag items have been resolved, rehabilitation measures have been completed, and the site is handed over to the Operator, thereby indicating the start of the operational phase.

#### *1.5.7 Environmental Officer (EO)*

The EO must be appointed by the Contractor and is responsible for managing the daily onsite implementation of the EMPr, and for the compilation of weekly environmental monitoring reports. In addition, the EO must act as liaison and advisor on all environmental and related issues, seek advice from the ECO when necessary, and ensure that any complaints received from I&APs are duly processed and addressed and that conflicts are resolved in an acceptable manner and timely manner. The EO must be a full time dedicated member of the Contractor's team and must be approved by the Project Company.

The following qualifications, qualities and experience are recommended for the individual appointed as the EO:

- A relevant environmental diploma or degree in natural sciences, as well as a minimum of three years' experience in construction site monitoring, excluding health and safety;
- A level-headed and firm person with above-average communication and negotiating skills. The ability to handle and address conflict management situations will be an advantage; and
- Relevant experience in environmental site management and EMPr compliance monitoring.

The EO's responsibilities include:

- Monitoring, on a daily basis, environmental specifications on site and compliance with the conditions of the EA, environmental legislation and EMPr;
- Keeping a register of compliance / non-compliance with the environmental specifications;
- Identifying and assessing previously unforeseen, actual or potential impacts on the environment;
- Ensuring that a brief weekly environmental monitoring report is submitted to the ECO;
- Conducting site inspections during the defects liability period, and bringing any environmental concerns to the attention of the ECO and Contractor;
- Advising the Contractor on the rectification of any pollution, contamination or damage to the construction site, rights of way and adjacent land;
- Attending site meetings (scheduled and *ad hoc*);
- Presenting the environmental awareness training course to all staff, Contractors and Sub contractors, and monitoring the environmental awareness training for all new personnel on-site, as undertaken by the Contractor;
- Ensuring that a copy of the EA and the latest version of the EMPr are available on site at all times;
- Ensuring that the Contractor is made aware of all applicable changes to the EMPr that are approved by the DEA;
- Assisting the Contractor in drafting environmental method statements and/or the Environmental Policy where such knowledge/expertise is lacking;
- Undertaking daily environmental monitoring to ensure the Contractor's activities do not impact upon the receiving environment. Such monitoring must include dust, noise and water monitoring; and
- Maintaining the following on site:
  - A weekly site diary.
  - A non-conformance register.
  - An I&AP communications register, and
  - A register of audits.

The EO will remain employed until all rehabilitation measures, as required for implementation due to construction damage, are completed and the site is handed over to the Operator.

### 1.5.8 Community Liaison Officer

The CLO must be employed by the Contractor and will be responsible for managing the daily on-site implementation of the social aspects of the EMPr. The CLO must liaise with landowners and relevant I&APs regarding construction activities for the duration of construction and will ensure that any discussions and complaints received from the public are addressed and that conflicts are resolved in an acceptable manner within 10 days.

The CLO(s) must be full time dedicated member(s) of the Contractor's team and must be accepted by the Project Company. The CLO must report to the Contractor's Project Manager, seeking advice from the ECO when necessary.

The CLO may be the same person as the EO, but will assume all the responsibilities of the dual role.

The following qualifications, qualities and experience are recommended for the individual appointed as the Contractor's CLO:

- A person with communication and negotiating skills;
- Report writing skills; and
- Fluency in English, Afrikaans and any other local language as and where required.

The responsibilities and functions of the Construction CLO will include:

- Implement and manage the daily social and communication aspects of the construction process according to the EMPr;
- Liaise and maintain good relations with I&APs;
- Monitor social aspects in terms of the specifications;
- Implement mitigation and corrective measures;
- Submit a monthly environmental report to the Contractor's Project Manager;
- Conduct site inspections during the defects notification period, and bring any social concerns to the attention of the Contractor;
- Attend site meetings (scheduled and ad hoc);
- Maintain a filing system meeting the project's quality management plan;
- Assist the Contractor in the drafting of social methods statements where such knowledge/expertise is lacking;
- Maintain the following on site:
  - A daily site diary;
  - A public complaints and communications register; and
  - A register of audits.
- Remain employed until the end of construction.

### 1.5.9 Responsible Parties and Auditing Process

As described above, **Table 2** below provides a summary of the responsible parties and the auditing process to be carried out.

**Table 2:** Responsible Parties and Auditing Process

TITLE	PARTY	ROLE DURING CONSTRUCTION	ROLE DURING OPERATION
Project Company	Special Purpose Vehicle (SPV) to be confirmed once registered	Assume ultimate responsibility	N/A
Grid Connection Owner	Eskom	N/A	Assume ultimate responsibility
Project Manager	To be appointed by proponent	Construction management	N/A
Contractor's Project Manager	Balance of Plant Contractor	Project management	N/A
Main Contractor/s	There will be multiple contracts placed and managed by the Contractor's Project Manager for the construction phase. These will cover civil earthworks and concrete, structural mechanical and electrical / instrumentation (CI). Then there could also be the construction camp management contract.	Main Contractor will undertake day to day construction activities covering aspects such as civil earthworks and concrete, structural mechanical and electrical / instrumentation (CI).	N/A
Environmental Officer	To be appointed by Main Contractors	Day to day environmental responsibility, point of contact for ECO	N/A
Environmental Control Officer	To be appointed by proponent	Monthly audits	Annual audits
Community Liaison Officer	To be appointed by Main Contractors	Day to day environmental responsibility, point of contact for landowners and I&APs	Monthly Audits
Determining Authority	National Department of Environmental Affairs (DEA)	Conduct site visits when necessary.	Conduct site visits when necessary

The following are the environmental management responsibilities (**Table 3**) of the various parties during construction and operational phases. Unless otherwise stated, the EMPr will be adhered to as follows:

- The EO will be the responsible party for all daily compliance of this EMPr during the construction phase;
- The monitoring party will be the ECO;
- Method of record keeping will be monthly audits undertaken by the ECO;
- Audit Technique will be the review of records and documentation (including EMPr/EA) that will be kept on site by the EO and/ or site inspections; and
- The Project Company will bear ultimate responsibility during the construction phase.
- Eskom will bear ultimate responsibility during the operational phase.

**Table 3: Environmental Management Responsibilities**

ITEM	PROJECT COMPONENT AND ACTIVITY	RESPONSIBLE PARTY	MONITORING PARTY	AUDIT TECHNIQUE
1.1	PRE-CONSTRUCTION (SITE ESTABLISHMENT)			
1.1.1	Site preparation	PROJECT COMPANY, MC, EO, ECO	PROJECT COMPANY, ECO	SITE VISIT
1.1.2	Consultation	MC, CLO	EO, ECO	SITE VISIT
1.1.3	Cumulative impacts	MC,	EO, ECO	SITE VISIT
1.1.4	Social and Environmental Management Systems	MC,	EO, ECO, CLO	SITE VISIT
2.1	CONSTRUCTION ACTIVITIES			
2.1.1	Site Clearing	MC,	EO, ECO	SITE VISIT
2.1.2	Construction traffic and access	MC, EO	ECO	SITE VISIT
2.1.3	Construction Camp	MC, EO, ECO	ECO	SITE VISIT
2.1.4	Environmental Education and Training	PROJECT COMPANY, MC	PROJECT COMPANY	SITE VISIT
2.1.5	Soils and Geology	MC, EO	ECO	SITE VISIT
2.1.6	Erosion Control	EO	ECO	SITE VISIT
2.1.7	Water Use and quality	EO	ECO	SITE VISIT
2.1.8	Surface and Groundwater	EO	ECO	RECORDS REVIEW
2.1.9	Waste Management	EO	ECO	SITE VISIT
2.1.10	Flora	EO	ECO	SITE VISIT
2.1.11	Fauna	EO	ECO	RECORDS REVIEW, SITE VISIT
2.1.12	Air quality	EO	ECO	RECORDS REVIEW
2.1.13	Noise and Vibrations	EO	ECO	RECORDS REVIEW
2.1.14	Energy use	EO	ECO	RECORDS REVIEW
2.1.15	Climate Change	EO	ECO	RECORDS REVIEW

2.1.1 6	Agricultural Potential	EO	ECO	RECORDS REVIEW
2.1.1 7	Employment	PROJECT COMPANY, MC	ECO	RECORDS REVIEW
2.1.1 8	Occupational Health and Safety	MC, EO	CLO	SITE VISIT
2.1.1 9	Health and Safety	MC, EO	CLO	SITE VISIT
2.1.2 0	Security	MC, EO	ECO	SITE VISIT
2.1.2 1	Social Environment	PROJECT COMPANY, MC, CLO	ECO	RECORDS REVIEW, SITE VISIT
2.1.2 2	Community Engagement	CLO	ECO	SITE VISIT
2.1.2 3	Visual Impact	EO	ECO	SITE VISIT
2.1.2 4	Heritage Impact	PROJECT COMPANY, MC, EO	ECO	SITE VISIT
2.1.2 5	Avifauna Impact	PROJECT COMPANY, MC, EO	ECO	SITE VISIT
3.1	OPERATION ACTIVITIES			
3.1.1	Construction Site Decommissioning	PROJECT COMPANY	ECO	RECORDS REVIEW
3.1.2	Operation and Maintenance	ESKOM	ECO	RECORDS REVIEW
3.1.3	Surface and Groundwater	ESKOM	ECO	RECORDS REVIEW
3.1.6	Pollution Control	ESKOM	ECO	RECORDS REVIEW
3.1.7	Biodiversity	ESKOM	ECO	RECORDS REVIEW
3.1.8	Waste Management	ESKOM	ECO	RECORDS REVIEW
3.1.9	Health and Safety	ESKOM	ECO	RECORDS REVIEW
3.1.1 0	Visual Impact	ESKOM	ECO	RECORDS REVIEW
3.1.1 1	Avifauna Impact	ESKOM	ECO	RECORDS REVIEW AND SITE VISIT



4.1	DECOMMISSIONING ACTIVITIES OF PROPOSED DEVELOPMENT			
4.1.1	Ongoing Stakeholder involvement	ESKOM, CLO	ESKOM	SITE VISIT
4.1.2	Community health and safety	ESKOM, CLO	ESKOM	RECORDS REVIEW
4.1.3	Waste management	ESKOM, EO	ESKOM, ECO	RECORDS REVIEW AND SITE VISIT
4.1.4	Surface and groundwater	ESKOM, EO	ESKOM, ECO	RECORDS REVIEW AND SITE VISIT
4.1.5	Biodiversity	ESKOM, EO	ESKOM, ECO	RECORDS REVIEW AND SITE VISIT
4.1.6	Air quality	ESKOM, EO	ESKOM, ECO	RECORDS REVIEW AND SITE VISIT

#### 1.5.10 Environmental Audits

**Table 4** below provides an outline of the generic process involved in the auditing process. It briefly describes the activities of the process initially beginning with defining the objectives and scope of the auditing process as well as the responsibilities of the various parties. The procedure for the auditing process is explained through to the production of audit findings and the compliance (or non-compliance) of the audit findings.

**Table 4:** Example of Procedure for Conducting Audits

Objective	To ensure that formal audits of the EMPr are scheduled and performed so as to verify compliance with the requirements of the EMPr.
Scope	This procedure describes the sequence of events required to perform a compliance audit and the verification of implemented corrective action.
Responsibilities	The ECO or a person authorised and appointed by him, is responsible for the maintenance of the Environmental Audit System  The ECO is responsible for the scheduling and execution of the audit, as well as the verification of the implementation of corrective action. At his/her discretion, this authority may be delegated to responsible company personnel or to an independent Environmental Auditing Authority to perform the audit on his/her behalf.

	<p>Auditors must have no direct responsibility in the area/ system being audited.</p> <p>They will be trained in techniques for auditing environmental management systems.</p> <p>The head of department (HOD)/ supervisor for an area/system to be audited (or a responsible person nominated by him/ her) will assist the audit team in the execution of the audit. The HOD will also be responsible for timely corrective actions based on the findings of the audit.</p>
Planning the audit	<p>The ECO or his authorised delegate, must plan the audit of a particular environmental area or system as follows:</p> <ul style="list-style-type: none"> <li>▪ He must inform, in writing, the contractor to be audited of the intention to conduct an audit at least two weeks prior to the audit. This notification should include the audit objective, scope and duration and any assistance required from the contractor.</li> <li>▪ On completion of the construction audit, an audit findings report must be prepared and submitted to the Project Company, project manager and construction team.</li> <li>▪ Corrective actions must be implemented, within four weeks after the audit, where possible.</li> </ul>
Audit Check List	<p>Auditing will be performed by collecting evidence for verification through interviews, relevant documentation and observation of activities and conditions. Instances of non-conformity to EMP criteria should be recorded. An environmental audit checklist can be used as a guide to address all relevant issues.</p>
Audit Compliance	<p>See below.</p>
Audit Findings and Reporting of non-compliances	<p>The audit team must review all evidence of their audit findings to decide on non-compliance. Audit findings of non-compliance must be documented and supported by evidence in the Audit Findings Report.</p> <p>The non-compliance findings will be communicated to the Project Manager and his representatives during an audit feedback meeting.</p>

## 1.6 Layout of Environmental Management Programme

### 1.6.1 Introduction

This EMP addresses both generic issues as well as specific issues. The generic and specific issues are each separated into different phases. Each phase has specific issues unique to that period of the

development and operation of the solar energy facility as well as associated infrastructure. The impact is identified and given a brief description. The phases of the development are then identified as below:

- Pre-construction (Site Establishment)
- Construction (including associated rehabilitation of affected environment)
- Operation Phase
- Decommissioning

This EMPr seeks to manage and keep to a minimum the negative impacts of a development and at the same time, enhance the positive and beneficial impacts.

The EMPr specifies mitigation measures for the following environmental aspects:

#### 1.6.2 *Pre-construction (Site establishment)*

- Site preparation
- Consultation
- Site clearing
- Social and Environmental Management Systems

#### 1.6.3 *Construction*

- Construction Camp
- Construction Traffic and Access
- Environmental Education and Training
- Soils and Geology
- Erosion Control
- Water Use and Quality
- Surface and Groundwater
- Waste Management
- Flora
- Fauna
- Air Quality
- Noise and Vibrations
- Energy Use
- Employment
- Occupational Health and Safety
- Security
- Social Environment
- Cultural and Heritage Artefacts

- Community Engagement
- Visual Impact

#### 1.6.4 *Operation*

- Construction Site Decommissioning
- Operation and Maintenance
- Surface and Groundwater
- Biodiversity
- Waste Management
- Health and Safety
- Visual Impact
- Avifauna
- Social

#### 1.6.5 *Decommissioning Phase*

- Ongoing Stakeholder involvement
- Community health and safety
- Waste Management
- Surface and Groundwater
- Biodiversity
- Air Pollution

### **1.7 Objectives of an EMPr**

The objectives of this EMPr are to:

- Identify a range of mitigation measures which could reduce and mitigate the potential impacts to minimal or insignificant levels
- To identify measures that could optimise beneficial impacts
- To create management structures that address the concerns and complaints of I&APs with regards to the development
- To establish a method of monitoring and auditing environmental management practices during all phases of development
- Ensure that the construction and operational phases of the project continues within the principles of Integrated Environmental Management and Environmental Management System (EMS) ISO 14001 Principles

- Detail specific actions deemed necessary to assist in mitigating the environmental impact of the project.
- Ensure that the safety recommendations are complied with.
- Propose mechanisms for monitoring compliance with the EMPr and reporting thereon.
- Specify time periods within which the measures contemplated in the EMPr are implemented, where appropriate.

The EMPr Seeks to highlight the following:

- Avoiding impacts by not performing certain actions
- Minimising impacts by limiting aspects of an action
- Rectifying impacts through rehabilitation, restoration, etc. of the affected environment
- Compensating for impacts by providing substitute resources or environments
- Minimising impacts by optimising processes, structural elements and other design features
- Provide ongoing monitoring and management of environmental impacts of a development and documenting of any digressions /good performances
- The EMPr is a legally binding document that all parties involved in the project must be made aware of.

#### 1.7.1 *Environmental Monitoring*

A monitoring programme will be implemented for the duration of the lifecycle of proposed development. This programme will include:

- **Monthly Audits During the Construction Phase**
  - According to the EMPr conditions which will be conducted by the ECO. These audits can be conducted randomly and do not require prior arrangement with the project manager.
  - Compilation of an audit report with a rating of the compliance with the EMPr. This report will be submitted to the relevant authorities.
- **Annual Audits During the Operational Phase**
  - Undertaken by the ECO.

The ECO must keep a photographic record of any damage to areas outside the demarcated site area. The date, time of damage, type of damage and reason for the damage must be recorded in full to ensure the responsible party is held liable. All claims for compensation emanating from damage should be directed to the ECO for appraisal. A register must be kept of all complaints from the landowner or community (Annexure A). All complaints / claims must be handled immediately to ensure timeous rectification / payment by the responsible party.

The EMPr will be made binding on all contractors operating on the site and must be included within the Contractual Clauses. Those responsible for environmental damage must pay the repair costs both to the

environment and human health and the preventative measures to reduce or prevent further pollution and/or environmental damage (the polluter pays principle).

## 1.8 Applicable Legislation, Development Strategies and Guidelines

The following legislation applies:

- Constitution of South Africa (Act No. 108 of 1996)
- National Environmental Management Act (Act No 107 of 1998) – NEMA
- Environment Conservation Act (Act No 73 of 1989)
- National Heritage Resources Act (Act No 25 of 1999)
- National Water Act (Act No 36 of 1998)
- National Environmental Management: Biodiversity (Act No. 10 of 2004)
- National Forests Act, 1998 (Act No. 84 of 1998)
- Conservation of Agricultural Resources Act No. 43 of 1983)
- Subdivision of Agricultural Land (Act No. 70 of 1970, as amended)
- National Road Traffic (Act No. 93 of 1996, as amended)
- Civil Aviation Act (Act No.13 of 2009)
- Occupational Health and Safety Act No. 85 of 1993
- National Environmental Management: Air Quality Act, 2004 (Act No. 39 of 2004)
- National Environmental Management: Waste Act, 2008 (Act No. 59 of 2008)
- Development Facilitation Act No. 67 of 1995
- National Protected Areas Act (Act No. 25 of 2003)

Several regulations will be applicable to the construction phase of the project. These guidelines are mentioned in the EMPr tables. Also of significance in this EMPr are:

- World Bank International Finance Corporation (IFC)
- EHS Guidelines
- Equator Principles

### 1.8.1 *The Equator Principles*

The Equator Principles (2013) are a financial industry benchmark for determining, assessing and managing social and environmental risk in project financing. A number of banks, exchanges and organisations worldwide have adopted the Principles as requirements to be undertaken for project funding on application and approval. Furthermore, certain funding institutions have not formally adopted the Principles, but require clients to be compliant with them in order to qualify for loans.

Under Principle 3, the Equator Principles establish the International Finance Corporations (IFC) Performance Standards and associated General and Sector Specific Environmental, Health and Safety Guidelines as the applicable social and environmental standards that a project should comply with if the project is located in a non-OECD country or OECD country that is not designated as high income.

The social and environmental assessment that is undertaken for a project establishes whether or not the project is in compliance with the IFC Performance Standards<sup>1</sup>.

According to these principles, the performance standards relevant to the proposed development are summarised in **Table 5**.

---

<sup>1</sup> **NB** A project does not seek compliance with the Equator Principles per se but the standards that the EP refers to. A financial institution that has adopted the EP must ensure that any projects it is financing meet the standards referred to and that it adopts an appropriate risk management system to ensure this.

**Table 5: IFC Performance Standards**

Performance Standard	Intent and objective
Assessment and Management of Environmental and Social Risks and Impacts (1)	<ul style="list-style-type: none"> <li>▪ Adverse and beneficial impacts should be identified within the project's Area of Influence. Emphasis on integrated assessment of social and environmental impacts.</li> <li>▪ Compliance with national legislation and IFC PS and EHS guidelines as appropriate.</li> <li>▪ Emphasis on avoidance of impacts wherever practical and where this is not feasible, minimizes, mitigate and compensate.</li> <li>▪ To ensure effective and ongoing stakeholder engagement</li> <li>▪ To assess specifically the capacity and commitment of clients to manage risks and opportunities over the course of the transaction.</li> </ul>
Labour and Working Conditions (2)	<ul style="list-style-type: none"> <li>▪ Looks at the working conditions by following these principles;</li> <li>▪ To establish and maintain the worker- management relationship (including specifically a human resources policy).</li> <li>▪ To promote fair treatment, non-discrimination and equal opportunity of employees (and some contractors) and meet national employment laws.</li> <li>▪ To protect the workforce by addressing child labour and forced labour.</li> <li>▪ To promote healthy and safe working conditions.</li> </ul>
Resource Efficiency and Pollution Prevention (3)	<ul style="list-style-type: none"> <li>▪ To avoid and minimize adverse impacts on human health and the environment by avoiding or minimizing pollution from project activities.</li> <li>▪ To promote the reduction of emissions that contributes to climate change.</li> </ul>
Community Health Safety and Security (4)	<ul style="list-style-type: none"> <li>▪ To avoid or minimise risks to and impacts on the health and safety of the local community during the project life cycle from both routine and non-routine circumstances.</li> <li>▪ To ensure that the use of security personnel is carried out in a legitimate manner that avoids or minimizes risks to the community's safety and security.</li> </ul>
Land Acquisition and Involuntary Resettlement (5)	<ul style="list-style-type: none"> <li>▪ To avoid or at least minimize involuntary resettlement wherever feasible by exploring alternative project designs.</li> <li>▪ To mitigate adverse social and economic impacts from land acquisition or restrictions on affected persons' use of land by; (i) providing compensation for loss of assets at replacement cost, and (ii) ensuring that resettlement activities are implemented with appropriate disclosure of information, consultation, and the informed participation of those affected.</li> <li>▪ To improve or at least restore the livelihoods and standards of living of displaced persons.</li> <li>▪ To improve living conditions among displaced persons through provision of adequate housing with security of tenure at resettlement sites.</li> </ul>





## 2 ENVIRONMENTAL DOCUMENTATION, REPORTING AND COMPLIANCE

### 2.1 Documentation

The Contractor must ensure the following documentation is kept on the project site for the full duration of the contract:

- Final Environmental Management Programme once approved by the DEA;
- EA issued by the DEA;
- Environmental Policy of the Contractor;
- Environmental method statements compiled by the Contractor;
- Weekly environmental monitoring records;
- Minutes and record of attendance of all environmental meetings;
- Environmental incident book;
- Communications register;
- Register of audits;
- Non-conformance reports; and
- Waste manifests.

#### 2.1.1 *Weekly Environmental Monitoring Report*

The EO will be required to provide the Main Contractor with a brief weekly environmental monitoring report covering the onsite events which occurred during the past week. This will highlight key performance areas and provide feedback on corrective and preventive actions taken. The EO will have the weekly reports submitted by the Contractor's Manager prior to submission to The Project Company for monthly reporting.

#### 2.1.2 *Site Meetings*

During the construction phase, weekly site meetings are undertaken which include environmental matters. This meeting must be chaired by a Senior Site Representative with the Project Company, Contractor(s), the EO ('s), and CLO ('s) in attendance. Where practical or necessary, the ECO will need to attend if possible.

#### 2.1.3 *Method Statements*

It is a statutory requirement to ensure the wellbeing of employees and of the environment. Therefore, the Contractor must submit a Method Statement to the Project Company and the ECO for approval prior to the commencement of construction works.

A Method Statement is a document detailing how a particular process will be carried out. It should detail the possible dangers/risks associated with the particular part of the project and the methods of control to be established and to show how the work will be managed in a safe and environmentally responsible manner. The method statement must also include the following information, where applicable:

- The type of construction activity;
- Timing and location of the activity;
- Construction procedures;
- Materials and equipment to be used;
- Transportation of the equipment to and from site;
- How the equipment/material will be moved while on site;
- Location and extent of construction site office and storage areas;
- Identification of impacts that might result from the construction activity;
- Population impacts;
- Community/institutional arrangements;
- Conflicts between local residents and newcomers;
- Individual and family level impacts;
- Community infrastructure needs;
- Intrusion impacts;
- Methodology and/or specifications for impact prevention or containment and for environmental monitoring;
- Emergency/disaster incident and reaction procedures (required to be demonstrated); and
- Rehabilitation procedures and continued maintenance of the impacted environment.

The Contractor will be accountable for all actions taken in non-compliance of the approved method statements. The Contractor must keep all the method statements and subsequent revisions on file, copies of which must be distributed to all relevant personnel for implementation.

The Contractor will be required to submit, as a minimum, the relevant method statements as requested by the ECO which are to be compliant with the conditions of the EMP for review prior to the start of that specific activity.

#### *2.1.4 Communications Register*

All complaints or communications that are received from I&APs or any other stakeholder must be recorded in a communications register. These complaints and communications will be brought to the attention of the Project Company / Eskom, whereupon it will be investigated and a response to the Complainant, I&APs or

stakeholder will be given within 10 days. The communications register must include the following information:

- Record the time and date of the complaint/communication;
- A detailed description of the complaint/communication;
- Action and resources used to correct the complaint;
- Photographic evidence of the complaint (where possible);
- A written response to the complainant indicating rectification of the complaint; and
- Information regarding the relevant authority that was contacted or notified in writing where applicable (person, time and date).

The relevant authorities include:

- Department of Water and Sanitation (e.g. for any incidents involving the contamination of water resources).
- DEA (e.g. for any significant incident of pollution of the soil and air).
- Department of Agriculture, Forestry and Fisheries (e.g. uses of appropriate herbicides for eradication of alien invasive species, and permits for trees of special concern).
- Department of Health (e.g. for incidents such as contamination of water resources, accidental spill of hazardous substances).
- Department of Transport (e.g. for the diversion of traffic due to construction activities).
- Department of Labour (e.g. for labour disputes).

#### *2.1.5 Photographic Record*

The EO and CLO will be required to compile a photographic record (dated) of all activities on site prior to the start of construction related activities, during the construction process and on completion of construction related works. This photographic record will include:

- A pre-construction site record
- Monthly environmental audit reports;
- Weekly environmental monitoring reports;
- Corrective action;
- Progress of environmental works; and
- Incidences of non-conformance.

#### *2.1.6 Waste Manifests*

The Contractor must ensure that all solid (including any hazardous) waste removed from site is disposed of at a registered landfill site or nearby waste transfer station with capacity to accept the project generated waste. The waste manifest must be kept on record for auditing purposes.

### 2.1.7 Good Housekeeping

The Contractor is to practice good housekeeping throughout the construction phase. This should eliminate disputes about responsibility, facilitate efficient and timeous running of the project. Over and above practicing accepted construction methods in accordance with SANS 10120, this should include measures to preserve the environment inside the work area. Records of such actions taken to ensure the maintenance and management of housekeeping must be recorded.

The Contractor must record and report upon environmental management measures undertaken to mitigate assessed impacts upon the environment.

### 2.1.8 Management and Control

The Contractor is to implement environmental management in a reasonable manner and should such management not prove effective, must implement measures to the satisfaction of the Project Company. Appropriate measures must include:

- Appointment of necessary resources to monitor and manage environmental requirements;
- Implement aspect-specific method statements to deal with emergency situations;
- Provision of adequate emergency response equipment to mitigate and manage an incident or emergency; and
- Provision of specific training related to implementation of environmental management requirements.

### 2.1.9 Recording and Reporting

The Contractor must maintain detailed records of parameters monitored. These detailed records must demonstrate the effectiveness of the management actions implemented to mitigate potential impacts. The Contractor must submit a monthly database/report of management works implemented to the Project Company, as part of the Contractors monthly report.

### 2.1.10 Monitoring

The Contractor must submit an Environmental Monitoring Method Statement which details the scope, nature, process, schedule and templates for environmental monitoring. The monitoring results must be used to determine the effectiveness of the management programme. All complaints, compliments or other comments relating to environmental management parameters are to be recorded in the site issues register of the Contractor for inclusion in the project issues register held by the Project Company.

Monitoring results and the associated required management and mitigation actions for the coming monitoring period are to be presented in the monitoring section of the Contractors monthly report. The daily and weekly reports are to detail observations and information relating to requested management actions and their effectiveness.

The Contractor must monitor and maintain the following on an ongoing basis:

- Re-growth of alien invasive vegetation;
- Validity of the pest control officer certificate;
- Fire break requirements associated to construction related activities;
- Stormwater systems;
- Topsoil and backfill volumes;
- Access road condition;
- Dust generated from stockpiles;
- Noise;
- Water quality;
- Erosion prevention; and
- Landscaping requirements for rehabilitation.

The Contractor must submit a monthly database of inter alia the following works to the Project Company. This data base is to include as a minimum:

- Extent of alien invasive clearing operations;
- Volumes of herbicide used on the project;
- Stockpile volumes of chipped material, topsoil, fertile soil and subsoil;
- Volume of recyclable waste removed from site;
- Water volumes recycled and used for dust suppression; and
- Maintenance of chemical toilets.

All complaints, compliments or other comments relating to construction related works are to be recorded by the Contractor in the communications register of the receiving party for inclusion in the project issues register. Site clearance monitoring results and the associated required management and mitigation actions for the coming monitoring period are to be presented in the monitoring section of the Contractors monthly report. The weekly reports are to detail observations and information relating to requested management actions and their effectiveness.

## **2.2 Compliance with the EMPr**

The Contractor/s is/are deemed not to have complied with the EMPr if:

- Within the boundaries of the site, site extensions and access roads there is evidence of contravention of clauses;
- If environmental damage ensues due to negligence;
- The contractor fails to comply with corrective or other instructions issued by the ECO or Authorities within a specified time; and
- The Contractor fails to respond adequately to complaints from the public.

The Project Company / Eskom is deemed not to have complied with the EMPr if:

- Within the boundaries of the site there is evidence of contravention of clauses;
- If environmental damage ensues due to negligence; and
- They fail to respond adequately to complaints from the public.

### 2.2.1 Non-Conformance Report

A Non-Conformance Report (NCR) will be issued to the Contractor as a final step towards rectifying a failure in complying with a requirement of the EMPr. This will be issued to the Contractor in writing. Preceding the issuing of the NCR, the Contractor will be presented with an opportunity to rectify the outstanding issue in a timely manner.

Preceding requirements to the submitting of the NCR will entail an issue that has been highlighted to the Contractor in the audits for corrective action. Should this issue not be corrected or completed to the satisfaction of the Project Company and ECO, the issue is escalated to an NCR.

Should the ECO assess an incident / issue and find it to be significant (e.g. non-repairable damage upon the environment), it will be reported to the DEA and immediately escalated to the level of an NCR. This will be done in consultation with the Project Company. The following information should be recorded in the NCR:

- Details of non-conformance;
- Any plant or equipment involved;
- Any chemicals or hazardous substances involved;
- Work procedures not followed;
- Any other physical aspects;
- Nature of the risk;
- Actions agreed to by all parties following consultation that should adequately address the identified non-conformance. This may take the form of specific control measures and should take the hierarchy of controls into account. This must accompany the NCR for filing purposes;
- The agreed timeframe by which the Contractor should have implemented the actions documented in the NCR; and
- The ECO should verify that the agreed actions have taken place on or soon after the agreed

completion date. Where the actions are complete, the ECO and Contractor should sign the Close Out portion of the Non-Conformance Form and file it with the contract documentation.

### 2.2.2 *Environmental Emergency Response*

The Contractor's environmental emergency procedures must ensure that there will be an appropriate response to unexpected or accidental actions or incidents that could cause environmental impacts. Such incidents may include:

- Accidental discharges to water (i.e. into a water resource) and land;
- Accidental spillage of hazardous substances (typically oil, petrol, and diesel);
- Accidental toxic emissions into the air;
- Specific environmental and ecosystem effects from accidental releases or incidents;
- The Environmental Emergency Response Plan is separate to the Health and Safety Plan as it is aimed at responding to environmental incidents and must ensure and include the following:
  - Construction employees must be adequately trained in terms of incidents and emergency situations;
  - Details of the organisation (manpower) and responsibilities, accountability and liability of personnel;
  - A list of key personnel and contact numbers;
  - Details of emergency services (e.g. the fire department, spill cleanup services) must be listed;
  - Internal and external communication plans, including prescribed reporting procedures;
  - Actions to be taken in the event of different types of emergencies;
  - Incident recording, progress reporting and remediation measures to be implemented; and
  - Information on hazardous materials, including the potential impact associated with each, and measures to be taken in the event of accidental release.

The Contractor(s) will comply with the environmental emergency preparedness and incident and accident-reporting requirements, as required by the Occupational Health and Safety Act (Act No. 85 of 1993), the National Environmental Management Act (Act No. 107 of 1998), the National Water Act (Act No. 36 of 1998), and/or any other relevant legislation.

### 2.2.3 *Non-compliance*

Non-conformance will be issued to the Contractor for incidents of non-compliance. The Contractor (through the Environmental Officer) must also take the necessary steps (e.g. training) to prevent a recurrence of the infringement. The Contractor is also advised that the imposition of non-conformance does not replace any legal proceedings the authorities, landowners and/or members of the public may institute against the Contractor. The Contractor must be required to make good any damage caused as a result of the



infringement at his own expense. A preliminary list of infringements for which non-conformance will be imposed is as follows:

- Using areas outside the working areas without permission/accessing “no-go areas”;
- Clearing and/or leveling area outside of the working areas;
- Littering on the site and surrounds;
- Burying/burning waste on site and surrounds;
- The undertaking of informal ablutions
- Making fires on site;
- Spillage onto the ground or water bodies of oil, diesel, or any other potential pollutants;
- Picking/damaging plant material, especially that from the residual areas of natural bush on the site;
- Damaging/killing wild or domestic animals/birds;
- Discharging effluent and/or stormwater onto the ground or into surface water;
- Repeated contravention of the specification or failure to comply with instruction;
- Mixing cement directly on soil or bare ground outside designated batching plant;
- Keeping animals as pets on site.

The Senior Site Supervisor, on recommendation from the ECO, may also order the Contractor to suspend part or all the works if the Contractor repeatedly causes damage to the environment by not adhering to the EMPr (i.e. more than 3 cases of infringements). The suspension will be enforced until such time as the offending actions, procedure or equipment is corrected. No extension of time will be granted for such delays and all costs will be borne by the Contractor.

#### *2.2.4 Training and Awareness*

The Main Contractor is to take responsibility for the management of their staff and subcontractors on the project site during the construction phase and supervise them closely at all times. The onus is on the Contractor to make sure that all their staff and subcontractors fully comprehend the contents of the EMPr. The Contractor must organise environmental awareness training programmes, which should, be targeted at the two levels of employment: management and labour.

##### *2.2.4.1 Training of Construction Workers*

The construction workers must receive basic training in environmental awareness, including the storage and handling of hazardous substances, minimisation of disturbance to sensitive areas, management of waste, and prevention of water pollution. They must be informed of how to recognise historical / archaeological artefacts that may be uncovered. They must also be apprised of the EMPr’s requirements. Environmental awareness training programmes need to be formulated for these levels and must comprise:

- A record of all names, positions and duties of staff to be trained;
- A framework for the training programmes;
- A summarised version of the training course(s); and
- An agenda for the delivery of the training courses.

Such programmes will set out the training requirements, which need to be conducted prior to any construction works occurring and will include:

- Acceptable behaviour with regard to flora and fauna;
- Management and minimising of waste, including waste separation;
- Maintenance of equipment to prevent the accidental discharge or spill of fuel, oil, lubricants, cement, mortar and other chemicals;
- Responsible handling of chemicals and spills;
- Environmental emergency procedures and incident reporting; and
- General code of conduct towards I&APs.

The ECO may be requested to provide additional training (in a first language) on-site regarding environmental aspects that are unclear to the construction personnel. A translator may be required and requested to assist in this additional training. The cost for the translator will be borne by the Contractor.

#### *2.2.4.2 Contractor Performance*

The Main Contractor must ensure that the conditions of the EMP are adhered to. Should the Main Contractor require clarity on any aspect of the EMP, the Main Contractor must contact the Environmental Control Officer for advice.

### 3 MITIGATION GUIDELINES

#### 3.1 Introduction

Mitigation guidelines are addressed through four phases namely Pre-construction (Site Establishment) Phase; Construction Phase (and associated rehabilitation of affected environment); Operational Phase (Post-Construction) as well as Decommissioning Phase. Each phase has specific issues unique to that period of the development and operation of the substation and power line. The impact is identified and given a brief description. The four phases of the development are then identified as below:

#### 3.2 Pre-construction (Site Establishment)

Requirements for the pre-construction phase

- Proper and continuous liaison between the ECO, the Contractor and Landowners to ensure all parties are appropriately informed at all times.
- The Contractor must adhere to all conditions of the contract including the Environmental Management Programme.
- Adequate planning of the construction programme to allow for disruptions due to rain and very wet conditions.
- Where existing private roads are in a bad state of repair, such roads' condition must be documented before they are used for construction purposes. This will allow for easy assessment of any damage to the roads which may result from the construction process. If necessary repairs must be done to prevent damage to equipment. All roads no matter what the condition need to be documented prior to construction.
- Proper documentation and record keeping of all complaints and actions taken.
- Appointment of an Environmental Control Officer to implement this EMP.
- Regular site inspections by the ECO and good control over the construction process throughout the construction period.
- Independent Environmental Audits to be carried out during and upon completion of construction. A formal communications protocol must be set up during the construction phase. The aim of the protocol must be to ensure that effective communication on key issues that must arise during this phase be maintained between key parties such as the ECO, project manager and contractor. The protocol must also ensure that concerns / issues raised by I&APs are formally recorded and considered and where necessary acted upon. If necessary, a forum for communicating with key stakeholders on a regular basis must be set up. This could be done through an Environmental Monitoring Committee that would meet on a regular basis. The communications protocol must be maintained throughout the construction phase.

### 3.3 Pre-Construction Phase

#### 3.3.1 Site Preparation

**Table 6:** Site preparation

IMPACT	SITE PREPARATION This section deals with the preparation of the site and actions that need to be implemented before construction commences	RESPONSIBILITY
PHASE	SITE ESTABLISHMENT	MC, ELO, ECO
<b>ENVIRONMENTAL MANAGEMENT PROGRAMME</b>		
<b>MITIGATION / METHOD STATEMENT</b>	<p><b>Appoint construction team and suitable manager</b></p> <ol style="list-style-type: none"> <li>1. Appoint an Environmental Control Officer and Environmental Liaison Officer. The ELO is appointed on the contractor's behalf while the ECO is appointed on the proponent's behalf.</li> <li>2. The Contractor must draw up method statements for relevant construction activities. The ECO must approve all of the method statements before they become operational.</li> </ol> <p><b>Site demarcation and compliance</b></p> <ol style="list-style-type: none"> <li>3. Before construction begins, the areas to be excavated for the pylons and stay wires must be barricaded with fencing or orange construction barrier.</li> <li>4. All tower positions must be pegged by a qualified surveyor prior to the onset of construction.</li> <li>5. All existing boreholes within the power line alignment have to be identified and surveyed.</li> <li>6. All Construction Camps are to be fenced off in such a manner that unlawful entry is prevented and access is controlled. Signage must be erected at all access points in compliance with all applicable occupational health and safety requirements. All access points to the Construction Camp must be controlled by a guard or otherwise monitored, to prevent unlawful access.</li> <li>7. The contractor and ECO must ensure compliance with conditions described in the EA.</li> </ol>	

IMPACT	<b>SITE PREPARATION</b> This section deals with the preparation of the site and actions that need to be implemented before construction commences	RESPONSIBILITY
PHASE	<b>SITE ESTABLISHMENT</b>	<b>MC, ELO, ECO</b>
<b>ENVIRONMENTAL MANAGEMENT PROGRAMME</b>		
	<p>8. All no-go areas on the servitude must be properly fenced off and signage placed prior to the onset of construction. If this is not practical (such as where the area is too large to fence off), the area must be demarcated with barrier tape and signage must be erected.</p> <p>9. Records of compliance / non-compliance with the conditions of the authorisation must be kept and be available on request.</p> <p>10. Records of all environmental incidents must be maintained and a copy of these records be made available to provincial department on request throughout the project execution.</p> <p>11. A suitable licensed landfill site must be identified, which will accept the type of waste material to be generated.</p> <p>12. A suitable site/borrow pit (if applicable) to obtain soil must be identified.</p> <p><b>Labour</b></p> <p>13. All unskilled labourers must be drawn from the local market and where possible use must be made of local semi-skilled and skilled personnel where possible.</p> <p><b>Training of site staff</b></p> <p>14. Environmental awareness training for construction staff, concerning the prevention of accidental spillage of hazardous chemicals and oil; pollution of water resources (both surface and groundwater), air pollution and litter control and identification of archaeological artefacts.</p> <p>15. Project Manager must ensure that the training and capabilities of the Contractor's site staff are adequate to carry out the designated tasks.</p>	

<b>IMPACT</b>	<b>SITE PREPARATION</b> This section deals with the preparation of the site and actions that need to be implemented before construction commences	<b>RESPONSIBILITY</b>
<b>PHASE</b>	<b>SITE ESTABLISHMENT</b>	<b>MC, ELO, ECO</b>
<b>ENVIRONMENTAL MANAGEMENT PROGRAMME</b>		
	<p>16. Staff operating equipment (such as loaders, etc.) must be adequately trained and sensitised to any potential hazards associated with their tasks.</p> <p>17. No operator must be permitted to operate critical items of mechanical equipment without having been trained by the Contractor and certified competent by the Project Manager.</p> <p>18. Staff must be educated as to the need to refrain from indiscriminate waste disposal and/or pollution of local soil and water resources and receive the necessary safety training.</p> <p>19. Staff must be trained in the hazards and required precautionary measures for dealing with these substances</p> <p>20. Spillage packs must be available at construction areas.</p>	
<b>SPECIFIC MITIGATION MEASURES</b>		
	<p>21. Pre-construction floral walk-through of the approved development footprint to ensure that sensitive habitats and species are avoided where possible.</p> <p>22. Access and service roads must be kept to a minimum and routes must also be adjusted to avoid areas of high sensitivity as far as possible, as informed by a preconstruction walk-through survey.</p> <p>23. Pre-construction faunal walk-through of the facility to identify areas of faunal sensitivity.</p> <p>24. Preconstruction environmental induction for all construction staff on site to ensure that basic environmental principles are adhered to. This includes topics such as no littering, appropriate handling of pollution and chemical spills, avoiding fire hazards, minimizing wildlife interactions, remaining within demarcated construction areas etc.</p> <p>25. A heritage walk down of the final approved layout will be required before construction commences.</p> <p>26. Any heritage features of significance identified during this walk down will require formal mitigation or where possible a slight change in design could accommodate such resources.</p>	

<b>IMPACT</b>	<b>SITE PREPARATION</b> This section deals with the preparation of the site and actions that need to be implemented before construction commences	<b>RESPONSIBILITY</b>
<b>PHASE</b>	<b>SITE ESTABLISHMENT</b>	<b>MC, ELO, ECO</b>
<b>ENVIRONMENTAL MANAGEMENT PROGRAMME</b>		
	27. A management plan for the heritage resources needs then to be compiled and approved for implementation during construction and operations.	

### 3.3.2 Consultation

**Table 7: Consultation**

<b>IMPACT</b>	<b>CONSULTATION</b> This section deals with the public consultation of the site and actions that need to be implemented before construction commences	<b>RESPONSIBILITY</b>
<b>PHASE</b>	<b>PRE-CONSTRUCTION</b>	<b>MC, ELO</b>
<b>ENVIRONMENTAL MANAGEMENT PROGRAMME</b>		
<b>MITIGATION / METHOD STATEMENT</b>	<b>Consultation</b> <ol style="list-style-type: none"> <li>1. Provide a mechanism through which information could be exchanged between the project proponent and stakeholders.</li> <li>2. Identify relevant stakeholders and engage them at applicable stages of the construction process.</li> <li>3. Inform the public about the proposed construction process.</li> <li>4. Surrounding communities must be kept informed, through the identified and agreed consultation channels, of the commencement of construction.</li> <li>5. Solicit views and concerns from the public and allow them to suggest mitigations and enhancement measures.</li> </ol>	

<b>IMPACT</b>	<b>CONSULTATION</b> This section deals with the public consultation of the site and actions that need to be implemented before construction commences	<b>RESPONSIBILITY</b>
<b>PHASE</b>	<b>PRE-CONSTRUCTION</b>	<b>MC, ELO</b>
<b>ENVIRONMENTAL MANAGEMENT PROGRAMME</b>		
	6. Determine stakeholder satisfaction levels.	

### 3.3.3 Site Clearing

**Table 8:** Site Clearing

<b>IMPACT</b>	<b>SITE CLEARING</b> This section deals with site clearing and actions that need to be implemented before construction commences	<b>RESPONSIBILITY</b>
<b>PHASE</b>	<b>PRE-CONSTRUCTION</b>	<b>MC, EO, ECO</b>
<b>ENVIRONMENTAL MANAGEMENT PROGRAMME</b>		
<b>MITIGATION/ METHOD STATEMENT</b>	<b>Site clearing</b> 1. The area cleared must be as small as feasibly possible 2. Site clearing must take place in a phased manner, as and when required. 3. Areas which are not to be constructed on within two (2) months must not be cleared to reduce erosion risks. 4. The area to be cleared must be clearly demarcated and this footprint strictly maintained. 5. Spoil that is removed from the site must be removed to an approved spoil site or a licensed landfill site. 6. The necessary silt fences and erosion control measures must be implemented in areas where these risks are more prevalent.	
<b>SPECIFIC MITIGATION MEASURES</b>		



	7. In terms of surface water, potential negative impacts are related primarily to the clearing of vegetation associated with surface water resources which results in loss of habitat and mitigation measures must be strictly implemented.	
--	---	--

### 3.4 Construction Phase

#### 3.4.1 Construction Camp

**Table 9:** Construction Camp

<b>IMPACT</b>	<b>CONSTRUCTION CAMP</b> This section deals with construction camp and actions that need to be implemented during construction	<b>RESPONSIBILITY</b>
<b>PHASE</b>	<b>CONSTRUCTION</b>	<b>MC, ELO, ECO</b>
<b>ENVIRONMENTAL MANAGEMENT PROGRAMME</b>		
<b>MITIGATION / METHOD STATEMENT</b>	<p><b>Site of construction camp</b></p> <ol style="list-style-type: none"> <li>Choice of site for the Contractor's camp requires the Project Manager and ECO's permission and must take into account location of local residents and / or ecologically sensitive areas, including flood zones. A site plan must be submitted to the Project Manager for approval.</li> <li>The size of the construction camp must be minimized (especially where natural vegetation or grassland has had to be cleared for its construction).</li> <li>Adequate parking must be provided for site staff and visitors. The Contractor must attend to drainage of the camp site to avoid standing water and / or sheet erosion.</li> <li>Suitable control measures over the Contractor's yard, plant and material storage to mitigate any visual impact of the construction activity must be implemented.</li> </ol> <p><b>Construction Camp</b></p>	

<b>IMPACT</b>	<b>CONSTRUCTION CAMP</b> This section deals with construction camp and actions that need to be implemented during construction	<b>RESPONSIBILITY</b>
<b>PHASE</b>	<b>CONSTRUCTION</b>	<b>MC, ELO, ECO</b>
<b>ENVIRONMENTAL MANAGEMENT PROGRAMME</b>		
	<ol style="list-style-type: none"> <li>5. The ECO and Contractor must inspect the Construction Camp site to confirm and note any environmental sensitivity.</li> <li>6. The construction camp layout plan must be provided to the ECO for approval prior to the construction of the camp.</li> <li>7. The construction camp must be fenced off and on-site security must be put in place prior to commencing with the construction activities.</li> <li>8. The Contractor must supply a wastewater management system that will comply with legal requirements and be acceptable to the Project Company if this does not already exist on the site.</li> <li>9. Site establishment must take place in an orderly manner and all required amenities must be installed at camp sites before the main workforce move onto site.</li> <li>10. All construction equipment must be stored within this construction camp or the farm under lease.</li> <li>11. No oil changes and servicing must take place on the construction site. All associated oil changes must take place on a sealed surface such as a concrete slab or a similar appropriate surface.</li> <li>12. All Construction Camps must be provided with portable fire extinguishing equipment, in accordance with all relevant legislation and must be readily accessible.</li> <li>13. The Contractor must provide sufficient ablution facilities (1 toilet per every 15 workers), in the form of portable / VIP toilets, at the Construction Camps, and must conform to all relevant health and safety standards and codes. No pit latrines, French drain systems or soak away systems must be allowed and toilets must not be situated within 50 meters of any surface water body or 1:100 year flood line. A sufficient number of toilets must be provided to accommodate the number of personnel working in the area.</li> </ol>	

<b>IMPACT</b>	<b>CONSTRUCTION CAMP</b> This section deals with construction camp and actions that need to be implemented during construction	<b>RESPONSIBILITY</b>
<b>PHASE</b>	<b>CONSTRUCTION</b>	<b>MC, ELO, ECO</b>
<b>ENVIRONMENTAL MANAGEMENT PROGRAMME</b>		
	<p>14. The Contractor must inform all site staff to make use of supplied ablution facilities and under no circumstances must indiscriminate sanitary activities be allowed.</p> <p>15. No fires will be allowed and the Contractor must make alternative arrangements for heating. LP Gas must be used, provided that all required safety measures are in place. The Contractor must take specific measures to prevent the spread of veld fires, caused by activities at the campsites. These measures must include appropriate instruction of employees about fire risks and the construction of firebreaks around the site perimeter.</p> <p>16. Must an area for cooking be required, it must be inspected and approved by the ECO prior to use.</p> <p><b>Storage of materials (including hazardous materials)</b></p> <p>17. An area for the storage of hazardous materials must be established that conforms to the relevant safety requirements and that provides for spillage prevention and containment.</p> <p>18. Choice of location for storage areas must take into account prevailing winds, distances to water bodies, general onsite topography and water erosion potential of the soil. Impervious surfaces must be provided where necessary.</p> <p>19. Storage areas must be designated, demarcated and fenced if necessary.</p> <p>20. Storage areas must be secure so as to minimize the risk of crime. They must also be safe from access by unauthorised persons i.e. children / animals etc.</p> <p>21. Fire prevention facilities must be present at all storage facilities.</p> <p>22. Proper storage facilities for the storage of oils, grease, fuels, chemicals and any hazardous materials to be used must be provided to prevent the migration of spillage into the ground and groundwater regime around the temporary storage area(s). These pollution prevention measures for storage must include a</p>	

IMPACT	<b>CONSTRUCTION CAMP</b> This section deals with construction camp and actions that need to be implemented during construction	RESPONSIBILITY
PHASE	CONSTRUCTION	MC, ELO, ECO
<b>ENVIRONMENTAL MANAGEMENT PROGRAMME</b>		
	<p>bund wall high enough to contain at least 110 of any stored volume, and this must be sited away from drainage lines on a site with the approval of the ECO. The bund wall must be high enough to contain 110 of the total volume of the stored hazardous material with an additional allocation for potential stormwater events.</p> <p>23. All fuel storage areas must be roofed to avoid creation of dirty stormwater</p> <p>24. These storage facilities (including any tanks) must be sited on an impermeable surface that is protected from the ingress of storm water from surrounding areas in order to ensure that accidental spillage does not pollute local soil or water resources.</p> <p>25. Material Safety Data Sheets (MSDSs) must be readily available on site for all chemicals and hazardous substances to be used on site. Where possible the available, MSDSs must additionally include information on ecological impacts and measures to minimise negative environmental impacts during accidental releases or escapes.</p> <p>26. Storage areas containing hazardous substances / materials must be clearly signposted.</p> <p>27. Staff dealing with these materials / substances must be aware of their potential impacts and follow the appropriate safety measures.</p> <p>28. All excess cement and concrete mixes are to be contained within a bunded area on the construction site prior to disposal off site.</p> <p>29. All major spills as specified in the contractor emergency response procedure of any materials, chemicals, fuels or other potentially hazardous or pollutant substances must be cleaned immediately, and the cause of the spill investigated. Preventative measures must be identified and submitted to the MC and ECO for information. Emergency response procedures to be followed and implemented.</p>	

<b>IMPACT</b>	<b>CONSTRUCTION CAMP</b> This section deals with construction camp and actions that need to be implemented during construction	<b>RESPONSIBILITY</b>
<b>PHASE</b>	<b>CONSTRUCTION</b>	<b>MC, ELO, ECO</b>
<b>ENVIRONMENTAL MANAGEMENT PROGRAMME</b>		
	<b>Drainage of construction camp</b> 30. Surface drainage measures must be established in the Construction Camps so as to prevent <ul style="list-style-type: none"> <li>▪ Ponding of water;</li> <li>▪ Erosion as a result of accelerated runoff; and,</li> <li>▪ Uncontrolled discharge of polluted runoff.</li> </ul>	

#### 3.4.2 Construction Traffic and Access

**Table 10:** Construction Traffic and Access

<b>IMPACT</b>	<b>CONSTRUCTION TRAFFIC AND ACCESS</b> This section deals with construction traffic and access and actions that need to be implemented during construction	<b>RESPONSIBILITY</b>
<b>PHASE</b>	<b>CONSTRUCTION</b>	<b>MC, EO, ELO</b>
<b>ENVIRONMENTAL MANAGEMENT PROGRAMME</b>		
<b>MITIGATION / METHOD STATEMENT</b>	<b>Construction traffic</b> <ol style="list-style-type: none"> <li>1. Construction routes and required access roads must be clearly defined.</li> <li>2. A route study is to be undertaken as part of the final traffic transportation plan to confirm the most appropriate route to site.</li> <li>3. Recommendations of the Stormwater Management Plan must be implemented.</li> <li>4. All equipment moved onto site or off site during a project is subject to the legal requirements.</li> </ol>	

IMPACT	<b>CONSTRUCTION TRAFFIC AND ACCESS</b> <b>This section deals with construction traffic and access and actions that need to be implemented during construction</b>	RESPONSIBILITY
PHASE	<b>CONSTRUCTION</b>	<b>MC, EO, ELO</b>
<b>ENVIRONMENTAL MANAGEMENT PROGRAMME</b>		
	<p>5. The Contractor must ensure that all the necessary precautions against damage to the environment and injury to persons are taken in the event of an accident.</p> <p>6. Access of all construction and material delivery vehicles must be strictly controlled, especially during wet weather to avoid compaction and damage to the topsoil structure.</p> <p>7. Damping down of the un-surfaced roads must be implemented to reduce dust and nuisance.</p> <p>8. Vehicles and equipment must be serviced regularly to avoid the contamination of soil from oil and hydraulic fluid leaks etc.</p> <p>9. Servicing must be done in dedicated service areas on site or else off site if no such area exists.</p> <p>10. Oil changes must take place on a concrete platform and over a drip tray to avoid pollution.</p> <p>11. Soils compacted by construction must be deep ripped to loosen compacted layers and re-graded to even running levels.</p> <p>12. Any temporary access roads to be rehabilitated prior to contractors leaving the site.</p> <p><b>Access</b></p> <p>13. The main routes on the site must be clearly signposted and printed delivery maps must be issued to all suppliers and Sub-Contractors.</p> <p>14. Planning of access routes to the site for construction purposes must be done in conjunction with the Contractor and the Landowner. All agreements reached must be documented and no verbal agreements must be made. The Contractor must clearly mark all access roads. Roads not to be used must be marked with a "NO ENTRY for construction vehicles" sign.</p> <p><b>Road maintenance</b></p> <p>15. Where necessary suitable measures must be taken to rehabilitate damaged areas.</p>	

<b>IMPACT</b>	<b>CONSTRUCTION TRAFFIC AND ACCESS</b> This section deals with construction traffic and access and actions that need to be implemented during construction	<b>RESPONSIBILITY</b>
<b>PHASE</b>	<b>CONSTRUCTION</b>	<b>MC, EO, ELO</b>
<b>ENVIRONMENTAL MANAGEMENT PROGRAMME</b>		
	<p>16. Contractors must ensure that access roads are maintained in good condition by attending to potholes, corrugations and storm water damages as soon as these develop.</p> <p>17. If necessary, staff must be employed to clean surfaced roads adjacent to construction sites where materials have spilt.</p> <p>18. Recommendations of the surface water report must be taken into consideration.</p> <p><b>General</b></p> <p>19. The contractor must meet safety requirements under all circumstances. All equipment transported must be clearly labelled as to their potential hazards according to specifications. All the required safety labelling on the containers and trucks used must be in place.</p> <p>20. Care for the safety and security of community members crossing access roads must receive priority at all times.</p>	
<b>SPECIFIC MITIGATION MEASURES</b>		
	<p>21. Ensure that roadworthy and safety standards are implemented at all times for all construction vehicles.</p> <p>22. Trips must be planned to avoid peak hours as far as possible (i.e. 06:00 - 08:00 and 16:00 – 17:00)</p> <p>23. Road kill monitoring programme must be established and fences erected where necessary to direct animals to safe road crossings on access roads.</p> <p>24. Management strategies for dust suppression to be implemented and dust generating activities to be suspended during periods of strong winds.</p> <p>25. Make use of existing gravel access roads where possible.</p> <p>26. As far as possible, limit the number of maintenance vehicles which are allowed to access the substation site and power line access roads.</p> <p>27. Main access roads to be inspected on a weekly basis for structural damage.</p>	

<b>IMPACT</b>	<b>CONSTRUCTION TRAFFIC AND ACCESS</b> This section deals with construction traffic and access and actions that need to be implemented during construction	<b>RESPONSIBILITY</b>
<b>PHASE</b>	<b>CONSTRUCTION</b>	<b>MC, EO, ELO</b>
<b>ENVIRONMENTAL MANAGEMENT PROGRAMME</b>		
	28. Road Maintenance Plan to be developed for the primary access to the site which addresses the following: <ul style="list-style-type: none"> <li>▪ Grading requirements;</li> <li>▪ Dust suppression requirements;</li> <li>▪ Drainage requirements;</li> <li>▪ Signage, and</li> <li>▪ Speed limits.</li> </ul>	

### 3.4.3 Environmental Education and Training

**Table 11:** Environmental Education and Training

<b>IMPACT</b>	<b>ENVIRONMENTAL EDUCATION AND TRAINING</b> This section deals with the environmental training of construction employees.	<b>RESPONSIBILITY</b>
<b>PHASE</b>	<b>CONSTRUCTION</b>	<b>PROJECT COMPANY, PM, EO, ECO</b>
<b>ENVIRONMENTAL MANAGEMENT PROGRAMME</b>		
<b>MITIGATION / METHOD STATEMENT</b>	<b>Environmental training</b> <ol style="list-style-type: none"> <li>1. The project company must appoint an ECO prior to construction</li> <li>2. Ensure that all site personnel have a basic level of environmental awareness training. The ECO will be responsible for the training and topics covered must include: <ul style="list-style-type: none"> <li>▪ What is meant by “Environment”</li> <li>▪ Why the environment needs to be protected and conserved</li> </ul> </li> </ol>	



IMPACT	ENVIRONMENTAL EDUCATION AND TRAINING This section deals with the environmental training of construction employees.	RESPONSIBILITY
PHASE	CONSTRUCTION	PROJECT COMPANY, PM, EO, ECO
<b>ENVIRONMENTAL MANAGEMENT PROGRAMME</b>		
	<ul style="list-style-type: none"> <li>▪ How construction activities can impact on the environment</li> <li>▪ What can be done to mitigate against such impacts</li> <li>▪ Awareness of emergency and spills response provisions</li> <li>▪ Social responsibility during construction e.g. being considerate to local residents</li> <li>▪ Specific mitigation measures stipulated in the EMPr and EA.</li> </ul> <p>3. Environmental awareness training for <u>all</u> construction staff must be undertaken by the ECO prior to construction starting. Translators are to be used where necessary. The topics covered must include, but not be limited to the following:</p> <ul style="list-style-type: none"> <li>▪ Use of the appropriate fire-fighting equipment</li> <li>▪ The need for a “clean site” policy</li> <li>▪ The prevention of accidental spillage of hazardous chemicals and oil</li> <li>▪ Pollution of water resources (both surface and groundwater)</li> <li>▪ Air pollution and litter control</li> <li>▪ The need to refrain from indiscriminant waste disposal and/or pollution of local soil and water resources</li> <li>▪ General safety</li> </ul> <p>4. Training of new staff that did not receive the initial training is the responsibility of the ECO.</p> <p>5. Staff operating equipment (such as cranes, etc.) must be adequately trained and sensitized to any potential hazards associated with their tasks.</p> <p>6. No operator must be permitted to operate critical mechanical equipment without having been trained by the Contractor and certified competent by the Project Manager.</p>	

<b>IMPACT</b>	<b>ENVIRONMENTAL EDUCATION AND TRAINING</b> This section deals with the environmental training of construction employees.	<b>RESPONSIBILITY</b>
<b>PHASE</b>	<b>CONSTRUCTION</b>	<b>PROJECT COMPANY, PM, EO, ECO</b>
<b>ENVIRONMENTAL MANAGEMENT PROGRAMME</b>		
	<b>Monitoring of environmental training</b> 7. The Contractor must monitor the performance of construction workers to ensure that the points relayed during their introduction have been properly understood and are being followed. If necessary, the ECO and / or a translator must be called to the site to further explain aspects of environmental or social behaviour that are unclear. Toolbox talks are recommended.	

### 3.4.4 Soils and Geology

General guidelines for management of soils are provided in **Annexure B**.

**Table 12:** Soils and Geology

IMPACT	SOILS AND GEOLOGY This section deals with soils and geology issues and actions that need to be implemented during construction	RESPONSIBILITY
PHASE	CONSTRUCTION	MC, EO, ECO
ENVIRONMENTAL MANAGEMENT PROGRAMME		
MITIGATION / METHOD STATEMENT	<p><b>Topsoil</b></p> <ol style="list-style-type: none"> <li>1. The contractor must, prior to the commencement of earthworks determine the average depth of topsoil (if any), and agree on this with the ECO. The full depth of topsoil must be stripped from areas affected by construction and related activities prior to the commencement of foundations. This must include the building footprints, working areas and storage areas. Topsoil must be reused where possible to rehabilitate disturbed surface areas.</li> <li>2. Care must be taken not to mix topsoil and subsoil during stripping.</li> <li>3. Must any topsoil become polluted the contractor must remove the polluted soil to the full depth of pollution and replace it at his own expense with clean topsoil.</li> <li>4. Removed polluted topsoil must be transported to a licensed landfill site.</li> <li>5. The topsoil must be conserved on site in and around the pit area</li> </ol> <p><b>Soil Stripping</b></p> <ol style="list-style-type: none"> <li>6. No soil stripping must take place on areas within the site that the contractor does not require for construction works or areas of retained vegetation.</li> <li>7. Subsoil and overburden in all construction and lay down areas must be stockpiled separately to be returned for backfilling in the correct soil horizon order.</li> </ol>	

IMPACT	<b>SOILS AND GEOLOGY</b> This section deals with soils and geology issues and actions that need to be implemented during construction	RESPONSIBILITY
PHASE	CONSTRUCTION	MC, EO, ECO
<b>ENVIRONMENTAL MANAGEMENT PROGRAMME</b>		
	<p>8. Construction vehicles must only be allowed to utilize existing tracks or pre-planned access routes.</p> <p><b>Soil Stockpiles</b></p> <p>9. Stockpiles must not be situated such that they obstruct natural water pathways.</p> <p>10. Stockpiles must not exceed 2m in height unless otherwise permitted by the Engineer.</p> <p>11. If stockpiles are exposed to windy conditions or heavy rain, they must be covered either by vegetation or geofabric, depending on the duration of the project. Stockpiles must further be protected by the construction of berms or low brick walls around their bases.</p> <p>12. Stockpiles must be kept clear of weeds and alien vegetation growth by regular weeding.</p> <p>13. Where contamination of soil is expected, analysis must be done prior to disposal of soil to determine the appropriate disposal route. Proof from an approved waste disposal site where contaminated soils are dumped if and when a spillage / leakage occurs must be attained and given to the project manager.</p> <p><b>Fuel storage</b></p> <p>14. Topsoil and subsoil to be protected from contamination. This must be monitored on a monthly basis by a visual inspection of diesel/oil spillage and pollution prevention facilities.</p> <p>15. Fuel and material storage must be away from stockpiles.</p> <p>16. Concrete and chemicals must be mixed on an impervious surface and provisions must be made to contain spillages or overflows into the soil.</p> <p>17. Any storage tanks containing hazardous materials must be placed in bunded containment areas with sealed surfaces. The bund walls must be high enough to contain 110% of the total volume of the stored hazardous material.</p>	

<b>IMPACT</b>	<b>SOILS AND GEOLOGY</b> This section deals with soils and geology issues and actions that need to be implemented during construction	<b>RESPONSIBILITY</b>
<b>PHASE</b>	<b>CONSTRUCTION</b>	<b>MC, EO, ECO</b>
<b>ENVIRONMENTAL MANAGEMENT PROGRAMME</b>		
	<p><b>Concrete mixing</b></p> <p>18. Must a concrete batching plant be required, it must be contained within a bunded area.</p> <p>19. Concrete mixing must only take place within designated areas.</p> <p>20. Ready mixed concrete must be utilised where possible.</p> <p>21. No vehicles transporting concrete to the site must be washed on site.</p> <p>22. If a batching plant is necessary, run-off must be managed effectively to avoid contamination of other areas of the site. Run-off from the batch plant must not be allowed to enter the storm water system.</p> <p><b>Earthworks</b></p> <p>23. Soils compacted during construction must be deeply ripped to loosen compacted layers and re-graded to even running levels. Topsoil must be re-spread over landscaped areas. The area must be re-vegetated upon completion of construction activities in accordance with the specifications of a landscape architect.</p>	

### 3.4.5 Erosion Control

**Table 13:** Erosion Control

IMPACT	EROSION CONTROL This section deals with erosion issues and actions that need to be implemented during construction	RESPONSIBILITY
PHASE	CONSTRUCTION	MC, EO, ECO
<b>ENVIRONMENTAL MANAGEMENT PROGRAMME</b>		
<b>MITIGATION / METHOD STATEMENT</b>	<ol style="list-style-type: none"> <li>1. Wind screening and stormwater control must be undertaken to prevent soil loss from the site.</li> <li>2. The use of silt fences and sand bags must be implemented in areas that are susceptible to erosion, if any.</li> <li>3. Other erosion control measures that can be implemented are as follows: <ul style="list-style-type: none"> <li>▪ Brush packing with cleared vegetation</li> <li>▪ Mulch or chip packing</li> <li>▪ Planting of vegetation</li> <li>▪ Hydroseeding / hand sowing</li> </ul> </li> <li>4. All erosion control mechanisms need to be regularly maintained.</li> <li>5. Seeding of topsoil and subsoil stockpiles to prevent wind and water erosion of soil surfaces.</li> <li>6. Retention of vegetation where possible to avoid soil erosion</li> <li>7. Vegetation clearance must be phased to ensure that the minimum area of soil is exposed to potential erosion at any one time.</li> <li>8. Re-vegetation of disturbed surfaces must occur immediately after construction activities are completed. This must be done through seeding with indigenous grasses that were present on the site prior to construction.</li> <li>9. No impediment to the natural water flow other than approved erosion control works is permitted.</li> </ol>	

<b>IMPACT</b>	<b>EROSION CONTROL</b> This section deals with erosion issues and actions that need to be implemented during construction	<b>RESPONSIBILITY</b>
<b>PHASE</b>	<b>CONSTRUCTION</b>	<b>MC, EO, ECO</b>
<b>ENVIRONMENTAL MANAGEMENT PROGRAMME</b>		
	10. To prevent stormwater damage, the increase in stormwater run-off resulting from construction activities must be estimated and the drainage system assessed accordingly. 11. Stockpiles not used in three (3) months after stripping must be seeded to prevent dust and erosion.	
<b>SPECIFIC MITIGATION MEASURES</b>		
	12. Implement an effective system of run-off control, where it is required, that collects and safely disseminates run-off water from all hardened surfaces and prevents potential down slope erosion. Any occurrences of erosion must be attended to immediately and the integrity of the erosion control system at that point must be amended to prevent further erosion from occurring there. This system must be in place and maintained during all phases of the development. 13. Maintain where possible all vegetation cover and facilitate re-vegetation of denuded areas throughout the site, to stabilise the soil against erosion. 14. Erosion must be controlled where necessary on top-soiled areas.	

3.4.6 Water Use and Quality

**Table 14:** Water Use and Quality

IMPACT	<b>WATER USE AND QUALITY</b> This section deals with water use and quality issues and actions that need to be implemented during construction	RESPONSIBILITY
PHASE	CONSTRUCTION	MC, EO, ECO, CLO
MITIGATION / METHOD STATEMENT	<p><b>Water Use</b></p> <ol style="list-style-type: none"> <li>1. Develop a sustainable water supply management plan to minimize the impact to natural systems by managing water use, avoiding depletion of aquifers and minimizing impacts to water users.</li> <li>2. Water must be reused, recycled or treated where possible.</li> <li>3. Consultation with key stakeholders to understand any conflicting water use demands and the community's dependency on water resources and conservation requirements within the area.</li> </ol> <p><b>Water Quality.</b></p> <ol style="list-style-type: none"> <li>4. The quality and quantity of effluent streams discharged into the environment including stormwater must be managed and treated to meet applicable effluent discharge guidelines.</li> <li>5. Efficient oil and grease traps or sumps must be installed and maintained at refuelling facilities, workshops, fuel storage depots, and containment areas and spill kits must be available with emergency response plans.</li> </ol> <p><b>Stormwater</b></p> <ol style="list-style-type: none"> <li>6. The site must be managed in order to prevent pollution of drains, downstream watercourses or groundwater, due to suspended solids and silt or chemical pollutants.</li> <li>7. Silt fences must be used to prevent any soil entering the stormwater drains.</li> <li>8. Temporary cut off drains and berms must be required to capture stormwater and promote infiltration.</li> <li>9. Promote a water saving mind set with construction workers in order to reduce water wastage.</li> </ol>	Engineer



IMPACT	<b>WATER USE AND QUALITY</b> <b>This section deals with water use and quality issues and actions that need to be implemented during construction</b>	RESPONSIBILITY
<b>PHASE</b>	<b>CONSTRUCTION</b>	<b>MC, EO, ECO, CLO</b>
	<p>10. New stormwater systems must be developed strictly in accordance with engineers' specifications in order to ensure efficiency.</p> <p>11. Hazardous substances (fuel) must be stored at least 20m from any water bodies on site to avoid pollution.</p> <p>12. The installation of the stormwater system must take place as soon as possible to attenuate stormwater from the construction phase as well as the operation phase.</p> <p>13. Earth, stone and rubble is to be properly disposed of, or utilized on site so as not to obstruct natural water pathways over the site. i.e. these materials must not be placed in stormwater channels, drainage lines or rivers.</p> <p>14. There must be periodic checking of the site's drainage system to ensure that the water flow is unobstructed.</p> <p>15. If a batching plant is necessary, run-off must be managed effectively to avoid contamination of other areas of the site. Untreated runoff from the batch plant must not be allowed to get into the storm water system or nearby streams, rivers or erosion channels or dongas.</p> <p><b>Concrete mixing</b></p> <p>16. Concrete contaminated water must not enter soil or any natural drainage system as this disturbs the natural acidity of the soil and affects plant growth.</p> <p><b>Public areas</b></p> <p>17. Food preparation areas must be provided with adequate washing facilities and food refuse must be stored in sealed refuse bins which must be removed from site on a regular basis.</p>	

<b>IMPACT</b>	<b>WATER USE AND QUALITY</b> This section deals with water use and quality issues and actions that need to be implemented during construction	<b>RESPONSIBILITY</b>
<b>PHASE</b>	<b>CONSTRUCTION</b>	<b>MC, EO, ECO, CLO</b>
	18. The contractor must take steps to ensure that littering by construction workers does not occur and persons must be employed on site to collect litter from the site and immediate surroundings, including litter accumulating at fence lines. 19. No washing or servicing of vehicles on site.	

3.4.7 Surface and Groundwater

**Table 15:** Surface and Groundwater

<b>IMPACT</b>	<b>SURFACE WATER AND GROUNDWATER</b> This section deals with surface and groundwater issues and actions that need to be implemented during construction	<b>RESPONSIBILITY</b>
<b>PHASE</b>	<b>CONSTRUCTION</b>	<b>MC, ECO, EO</b>
<b>ENVIRONMENTAL MANAGEMENT PROGRAMME</b>		
<b>MITIGATION / METHOD STATEMENT</b>	<p><b>Sanitation</b></p> <ol style="list-style-type: none"> <li>1. Adequate sanitary facilities and ablutions must be provided for construction workers (1 toilet per every 15 workers).</li> <li>2. The facilities must be regularly serviced to reduce the risk of surface or groundwater pollution.</li> </ol> <p><b>Hazardous materials</b></p> <ol style="list-style-type: none"> <li>3. Use and / or storage of materials, fuel and chemicals which could potentially leak into the ground must be controlled.</li> <li>4. All storage tanks containing hazardous materials must be placed in bunded containment areas with sealed surfaces. The bund walls must be high enough to contain 110% of the total volume of the stored hazardous material.</li> <li>5. The Contractor (monitored by the ECO or EO) must be responsible for ensuring that potentially harmful materials are properly stored in a dry, secure, ventilated environment, with concrete or sealed flooring and a means of preventing unauthorised entry.</li> <li>6. Contaminated wastewater must be managed by the Contractor to ensure that existing water resources on the site are not contaminated. All wastewater from general activities in the camp must be collected and removed from the site for appropriate disposal at a licensed commercial facility.</li> </ol> <p><b>Water resources</b></p>	

	<p>7. Site staff must not be permitted to use any open water body or natural water source adjacent to or within the designated site for the purposes of bathing, washing of clothing or for any construction or related activities.</p> <p>8. Municipal water (or another source approved by the ECO) must instead be used for all activities such as washing of equipment or disposal of any type of waste, dust suppression, concrete mixing, compacting, etc.</p> <p>9. Relevant departments and other emergency services must be contacted in order to deal with spillages and contamination of aquatic environments.</p>	
<b>SITE SPECIFIC MITIGATION MEASURES</b>		
	<p><b>Designation of Highly Sensitive Areas</b></p> <p>10. The wetlands and drainage lines must be designated as “highly sensitive” and any impact must be limited to the minimum possible extent. All wetlands and drainage lines must be visibly demarcated prior to construction activities taking place where construction is within 50m of any delineated surface water resource. The demarcation of wetlands and drainage lines must be visible and last for the duration of the construction activities.</p> <p><b>Establishment of Internal Road Crossing Areas</b></p> <p>11. For general access to erect the pylons for the grid lines, existing roads are to be used as far as possible. Where no other access exists to the desired construction areas and roads will have to be routed through surface water resources and associated buffer zones, environmental authorisation and a water use license / general authorisation will be required before construction takes place. All mitigation measures are to be implemented accordingly.</p> <p>12. Where roads are routed through surface water resources, a single access route or road crossing area is to be established before construction takes place. The access route must follow existing routes where present. However, where new routes are to be established, temporary or permanent Ford (or low-water) crossings using the drainage line bed as part of the road and / or similar design crossings are to be established. Temporary ford crossings and / or similar design crossings can be planned where construction vehicles need to temporarily access proposed construction areas during construction the</p>	

construction phase only. Where the access routes will form part of permanent access and / or service roads, permanent ford crossings and / or similar design crossings will however be required. Given the study area, and the temporary nature of surface water resources to be potentially affected, the ford designs must be adequate since it enables hydrological continuity of the identified temporary surface water resources, maintains substrate continuity as well as allows movement of riparian and wetland bound species. To establish a temporary ford crossing, little to no modification of the drainage line will be required where banks are low (approximately 1,2m) for drainage lines, where the grade or approach to the drainage line does not exceed 5:1 (horizontal to vertical) and lastly, where the stream bed is firm rock or gravel. Ideally, fords and / or similar design crossings must maintain the natural shape and elevation of the drainage line. However, where modification is required, the banks and bed will have to be reinstated after construction has finished. Modifications to the banks must include limited grading, excavation of steep slopes, establishment of clean gravel approach to drainage line and wetland banks, placement of road base, etc. Such modifications are likely to be required for crossings through surface water resources with soft substrate. To establish the temporary bed crossing, use of materials to construct temporary mats made of wood or tyres can be used. Modifications will however need to be approved by the relevant environmental and water regulatory authorities prior to construction.

13. For permanent ford crossings and / or similar design crossings, rock or gravel must be used on weak drainage line beds. The weak substrate layer will need to be excavated and infilled by the rock or gravel material to the same level of the original drainage line. A minimum of approximately 30cm of infill must typically be used unless soil depth is limited. A geotextile can be used to separate the infill from the bed of the surface water resource thereby providing additional support.
14. Where other designs are more appropriate and these can be implemented, subject to approval from the relevant environmental and water regulatory authorities prior to construction.
15. In general, the width of the internal road crossing areas must be limited to the width of the vehicles required to move through the relevant surface water resource(s). The internal road crossing areas must be made clearly visible by means of demarcation during construction. Ideally, for temporary ford crossings and / or similar design crossings, vegetation must not be totally cleared across the entire internal road crossing areas. Rather, only the vehicle tracks must be cleared. Remaining vegetation can

be kept trimmed to below 20cm but not lower than 5cm in height. Trees or shrubs must however require removal. Permits must be obtained where sensitive or protected vegetation species are to be removed. Preferably, these must be relocated.

16. Erosion inspections will need to be undertaken regularly (as often as environmental compliance monitoring is undertaken by a suitably qualified Environmental Compliance Officer (ECO) during the construction phase, and monthly during the operation phase) in order to manage the integrity of the temporary / permanent ford crossings and / or similar crossing designs. Additionally, rehabilitation will need to take place if and where required.
17. Overall, no wetlands and / or drainage lines are to be crossed during or directly after a rainfall event. Use of internal road crossing areas are only permissible after rainfall events once flows have ceased.
18. Preferably light vehicles are to be utilised where possible. Where heavy vehicles (such as TLB's) must be used, extreme caution is to be exercised when entering the internal road crossing areas of wetlands and drainage lines due soil instability factors.
19. Construction personnel are only allowed in the designated internal road crossing areas. Any personnel traversing through the wetlands and / or drainage lines must be instructed not to light any fires, and / or remove any vegetation.

#### **Control of Alien and Invasive Vegetation in Surface Water Resources**

20. Control of alien and invasive vegetation within surface water resources will be required. Where alien and invasive vegetation encroachment / colonization takes place, these areas are to be cleared as soon as practically possible. Clearing must take place by means of mechanical removal, either by physically pulling or slashing and clearing of unwanted alien and invasive vegetation near or within the surface water resources. Monitoring of alien and invasive vegetation must be undertaken in accordance with the environmental compliance monitoring during the construction phase.

#### **Avoidance of Direct Impact to Delineated Surface Water Resources**

21. The substations or any other permanent building structures must not be placed directly within any of the identified and delineated wetlands and / or drainage lines.

**Emergency Measures**

22. Operational fire extinguishers are to be available in the case of a fire emergency. Given the dry seasons and variable winds that the region experiences, it is recommended that a fire management and emergency plan is compiled. A suitably qualified health and safety officer must compile the fire management and emergency plan for the operation and maintenance phase of the project.

**Buffer Zone Specific Mitigation Measures**

23. During construction activities, the outer extent of the buffer zones of the wetlands and drainage lines must be designated as “sensitive” and any impact must be limited to the minimum possible extent. The buffer zone extent must be visibly demarcated prior to construction activities taking place where construction is within 50m. The demarcation of the buffer zones must be visible and last for the duration of the construction activities.

24. The buffer zone areas are also subject to the mitigation measures applied to the internal road crossing areas through surface water resources.

**Preventing Increased Run-off, Erosion and Sedimentation Impacts**

25. Vegetation clearing must take place in a phased manner, only clearing areas for immediate construction. Vegetation clearing must not take place in areas where construction will only take place in the distant future.

26. An appropriate storm water management plan formulated by a suitably qualified professional must accompany the proposed development to deal with increased run-off in the designated construction areas.

27. In general, adequate structures must be put into place (temporary or permanent where necessary in extreme cases) to deal with increased/accelerated run-off and sediment volumes. The use of silt fencing and potentially sandbags or hessian “sausage” nets can be used to prevent erosion in susceptible construction areas. Grass blocks on the perimeter of building structure footprints can also be used to reduce run-off and the onset of erosion.

28. Where required more permanent structures such as attenuation ponds and gabions can be constructed if needs be, however this is unlikely given the study area. All impacted areas are to be adequately sloped to prevent the onset of erosion.
29. Erosion control management will need to be undertaken at the onset of construction. Regular monitoring and adequate erosion preventative measures (such as run-off protection as stipulated above) are to be implemented as and where required.

**Preventing Soil and Water Contamination**

30. No vehicles are to be allowed in the highly sensitive and sensitive areas unless authorised. Should vehicles be authorized in highly sensitive areas, all vehicles and machinery are to be checked for oil, fuel or any other fluid leaks before entering the required construction areas. Should there be any oil, fuel or any other fluid leaks, vehicles and machinery are not to be allowed into any drainage sensitive and highly sensitive areas.
31. All vehicles and machinery must be regularly serviced and maintained before being allowed to enter the construction areas. No fuelling, re-fuelling, vehicle and machinery servicing or maintenance is to take place in the highly sensitive and sensitive areas.
32. Sufficient spill contingency measures must be available throughout the construction process. These include, but are not limited to oil spill kits and fire extinguishers. These substances must also be contained in bunded areas with a capacity of at least 110 .
33. No “long drop” toilets are allowed on the construction site. Suitable temporary chemical sanitation facilities are to be provided. Temporary chemical sanitation facilities must not be placed directly within any surface water resource(s) or the associated buffer zones. Temporary chemical sanitation facilities must be checked regularly for maintenance purposes and cleaned often to prevent spills.
34. No cement mixing is to take place in any surface water resource. In general, any cement mixing must take place over a bin lined (impermeable) surface or alternatively in the load bin of a vehicle to prevent the mixing of cement with the ground. Importantly, no mixing of cement directly on the surface is allowed in the highly sensitive and sensitive areas.



**Preventing Impacts to Fauna Associated with Drainage lines and Wetlands**

35. No animals on the construction site or surrounding areas are to be hunted, captured, trapped, removed, injured, killed or eaten by construction workers or any other project team members. Should any party be found guilty of such an offence, stringent penalties must be imposed. The appointed Environmental Control Officer (ECO) or suitably qualified individual must only remove animals, where such animals (including snakes, scorpions, spiders etc.) are a threat to construction workers. The ECO or appointed individual is to be contacted should removal of any fauna be required during the construction phase. Animals that cause a threat and need to be removed, must not be killed. Additionally, these animals are to be relocated outside the internal road crossing areas or construction areas, within relatively close proximity to where they were found.

3.4.8 Waste Management

**Table 16:** Waste Management

IMPACT	WASTE MANAGEMENT This section deals with waste management issues and actions that need to be implemented during construction	RESPONSIBILITY
PHASE	CONSTRUCTION	MC, EO, ECO
<b>ENVIRONMENTAL MANAGEMENT PROGRAMME</b>		
MITIGATION / METHOD STATEMENT	<p><b>Litter management</b></p> <ol style="list-style-type: none"> <li>1. Refuse bins must be placed at strategic locations to ensure that litter does not accumulate within the construction site.</li> <li>2. The Contractor must supply waste collection bins where such are not available and all solid waste collected must be disposed of at registered/licensed landfill.</li> <li>3. A housekeeping team must be appointed to regularly maintain the litter and rubble situation on the construction site.</li> <li>4. If possible and feasible, all waste generated on site must be separated into glass, plastic, paper, metal and wood and recycled. An independent contractor can be appointed to conduct this recycling.</li> <li>5. Littering by the employees of the Contractor must not be permitted under any circumstances. The ECO must monitor the neatness of the work sites as well as the Contractor campsite.</li> <li>6. Skip waste containers must be maintained on site. These must be kept covered and arrangements made for them to be collected regularly.</li> <li>7. All waste must be removed from the site and transported to a landfill site promptly to ensure that it does not attract vermin or produce odours.</li> <li>8. Where a registered waste site is not available close to the construction site, the Contractor must provide a method statement with regard to waste management.</li> <li>9. A certificate of disposal must be obtained by the Contractor and kept on file, if relevant.</li> <li>10. Under no circumstances may solid waste be burnt on site.</li> </ol>	

IMPACT	<b>WASTE MANAGEMENT</b> This section deals with waste management issues and actions that need to be implemented during construction	RESPONSIBILITY
PHASE	CONSTRUCTION	MC, EO, ECO
<b>ENVIRONMENTAL MANAGEMENT PROGRAMME</b>		
	<p>11. All waste must be removed promptly to ensure that it does not attract vermin or produce odours.</p> <p>12. An approved waste disposal contractor must be employed to remove and recycle waste oil, if practical. The contractor must ensure that its personnel are made aware of the health risks associated with any hazardous substances used, have been provided with the appropriate protective clothing/equipment in case of spillages or accidents and have received the necessary training.</p> <p><b>Hazardous waste</b></p> <p>13. All hazardous waste materials, if present, must be carefully stored as advised by the ECO, and then disposed of off-site at a licensed landfill site, where practical.</p> <p>14. Contaminants to be stored safely to avoid spillage.</p> <p>15. Machinery must be properly maintained to keep oil leaks in check</p> <p>16. All necessary precaution measures must be taken to prevent soil or surface water pollution from hazardous materials used during construction and any spills must immediately be cleaned up and all affected areas rehabilitated</p> <p><b>Sanitation</b></p> <p>17. Toilets must be no closer than 100m or above the 1:100 year flood line from any natural or manmade water bodies or drainage lines or alternatively located in a place approved of by the Engineer.</p> <p>18. Under no circumstances must open areas, neighbours' fences or the surrounding bush be used as a toilet facility.</p> <p>19. The construction of "Long Drop" toilets is forbidden. Rather, portable toilets are to be used.</p> <p>20. Potable water must be provided for all construction staff.</p>	

IMPACT	<b>WASTE MANAGEMENT</b> This section deals with waste management issues and actions that need to be implemented during construction	RESPONSIBILITY
PHASE	CONSTRUCTION	MC, EO, ECO
<b>ENVIRONMENTAL MANAGEMENT PROGRAMME</b>		
	<p><b>Remedial actions</b></p> <p>21. Depending on the nature and extent of the spill, contaminated soil must be either excavated or treated on-site.</p> <p>22. Excavation of contaminated soil must involve careful removal of soil using appropriate tools/machinery to storage containers until treated or disposed of at a licensed hazardous landfill site.</p> <p>23. The ECO must determine the precise method of treatment for polluted soil. This could involve the application of soil absorbent materials as well as oil-digestive powders to the contaminated soil.</p> <p>24. If a spill occurs on an impermeable surface such as cement or concrete, the surface spill must be contained using oil absorbent material.</p> <p>25. If necessary, oil absorbent sheets or pads must be attached to leaky machinery or infrastructure.</p> <p>26. Materials used for the remediation of petrochemical spills must be used according to product specifications and guidance for use.</p> <p>27. Contaminated remediation materials must be carefully removed from the area of the spill so as to prevent further release of petrochemicals to the environment, and stored in adequate containers until appropriate disposal.</p>	

3.4.9 Flora

Table 17: Flora

IMPACT	FLORA This section deals with floral issues and actions that need to be implemented during construction	RESPONSIBILITY
PHASE	CONSTRUCTION	MC, EO, ECO
<b>ENVIRONMENTAL MANAGEMENT PROGRAMME</b>		
<b>MITIGATION / METHOD STATEMENT</b>	<p><b>Existing vegetation</b></p> <ol style="list-style-type: none"> <li>1. Vegetation removal must be limited to the 31m servitude.</li> <li>2. Vegetation to be removed as it becomes necessary rather than removal of all vegetation throughout the site in one step.</li> <li>3. Materials must not be delivered to the site prematurely which could result in additional areas being cleared or affected.</li> <li>4. No vegetation to be used for firewood.</li> <li>5. Smaller vegetation can be flattened with a machine, but the blade must be kept above ground level to prevent scalping. Any vegetation cleared on a tower site must be removed or flattened and not be pushed to form an embankment around the tower.</li> <li>6. Trees and vegetation not interfering with the statutory clearance to the conductors can be left under the line. Dense vegetation under the line which could cause a fire hazard, particularly in the middle third of the span in the vicinity of the lowest point of the conductors, will be considered as a separate case.</li> <li>7. Upon completion of the stringing operations and before handover, the servitude must be inspected and all vegetation interfering with the safe operation of the line must be removed / cut down.</li> </ol> <p><b>Rehabilitation</b></p> <ol style="list-style-type: none"> <li>8. All damaged areas must be rehabilitated upon completion of the contract</li> </ol>	

IMPACT	<b>FLORA</b> This section deals with floral issues and actions that need to be implemented during construction	RESPONSIBILITY
PHASE	<b>CONSTRUCTION</b>	<b>MC, EO, ECO</b>
<b>ENVIRONMENTAL MANAGEMENT PROGRAMME</b>		
	<p>9. Re-vegetation of the disturbed site is aimed at approximating as near as possible the natural vegetative conditions prevailing prior to construction.</p> <p>10. All natural areas impacted during construction must be rehabilitated with locally indigenous species typical of the representative botanical unit. Seeds from surrounding seed banks can be used for re-seeding.</p> <p>11. Rehabilitation must take place in a phased approach as soon as possible.</p> <p>12. Rehabilitation must be executed in such a manner that surface run-off will not cause erosion of disturbed areas.</p> <p><b>Demarcation of construction and laydown areas</b></p> <p>13. All plants not interfering with the construction must be left undisturbed. Species of special concern must be clearly marked.</p> <p>14. The construction area must be well demarcated and no construction activities must be allowed outside of this demarcated footprint</p> <p>15. Vegetation removal must be phased in order to reduce impact of construction.</p> <p>16. Strict and regular auditing of the construction process to ensure containment of the construction and laydown areas.</p> <p>17. Soils must be kept free of petrochemical solutions that must be kept on site during construction. Spillage can result in a loss of soil functionality thus limiting the re-establishment of flora.</p> <p><b>Utilisation of resources</b></p> <p>18. Gathering of firewood, fruit, muti plants, or any other natural material onsite or in areas adjacent to the site is prohibited unless with prior approval of the ECO.</p>	

IMPACT	<b>FLORA</b> This section deals with floral issues and actions that need to be implemented during construction	RESPONSIBILITY
PHASE	<b>CONSTRUCTION</b>	<b>MC, EO, ECO</b>
<b>ENVIRONMENTAL MANAGEMENT PROGRAMME</b>		
	<p><b>Exotic vegetation</b></p> <p>19. Alien vegetation on the site will need to be controlled.</p> <p>20. The contractor must be responsible for implementing a programme of weed control (particularly in areas where soil has been disturbed); and grassing of any remaining stockpiles to prevent weed invasion.</p> <p>21. The spread of exotic species occurring throughout the site must be controlled.</p> <p><b>Herbicides</b></p> <p>22. Herbicide use must only be allowed according to contract specifications. Application of herbicides must be according to set specifications and under the supervision of a qualified technician. The possibility of leaching into the surrounding environment must be properly investigated and only environmentally friendly herbicides must be used.</p> <p>23. The use of pesticides and herbicides on the site must be discouraged as these impact on important pollinator species of indigenous vegetation.</p>	
<b>SPECIFIC MITIGATION MEASURES</b>		
	<p>24. Placement of pylons and other infrastructure within the High Sensitivity areas and drainage lines must be avoided.</p> <p>25. Ensure that lay-down and other temporary infrastructure is within low sensitivity areas, preferably previously transformed areas if possible.</p> <p>26. Minimise the development footprint as far as possible and rehabilitate disturbed areas that are no longer required by the operational phase of the development. Construction activity must be restricted to the immediate footprint of the infrastructure.</p>	

<b>IMPACT</b>	<b>FLORA</b> This section deals with floral issues and actions that need to be implemented during construction	<b>RESPONSIBILITY</b>
<b>PHASE</b>	<b>CONSTRUCTION</b>	<b>MC, EO, ECO</b>
<b>ENVIRONMENTAL MANAGEMENT PROGRAMME</b>		
	Demarcate all areas to be cleared with construction tape or other appropriate and effective means. However caution must be exercised to avoid using material that might entangle fauna. Measures to control noise and dust must be applied according to current best practice in the industry.	



3.4.10 Fauna

**Table 18:** Fauna

IMPACT	FAUNA This section deals with faunal issues and actions that need to be implemented during construction	RESPONSIBILITY
PHASE	CONSTRUCTION	MC, EO, ECO
<b>ENVIRONMENTAL MANAGEMENT PROGRAMME</b>		
<b>MITIGATION / METHOD STATEMENT</b>	<ol style="list-style-type: none"> <li>1. Demarcation of sensitive areas must be verified on site by the ECO prior to construction activities starting.</li> <li>2. Rehabilitation to be undertaken as soon as possible after construction has been completed.</li> <li>3. No trapping or snaring of fauna on the construction site is allowed unless dangerous/venomous snakes are found. In this case all staff must be provided with the appropriate snake handling and removal training and the necessary permits must be obtained from the relevant conservation authority before any snakes are trapped and removed from the site.</li> <li>4. No faunal species are to be harmed by maintenance staff during any routine maintenance at the development.</li> <li>5. No animals are to be kept as pets.</li> <li>6. All personnel must undergo environmental induction with regards to fauna and in particular awareness about not harming or collecting species such as snakes, tortoises and owls which are often persecuted out of superstition.</li> </ol>	
<b>SPECIFIC MITIGATION MEASURES</b>		
	<ol style="list-style-type: none"> <li>7. During construction any fauna directly threatened by the construction activities must be removed to a safe location by the ECO or other suitably qualified person.</li> <li>8. Any trenches that are required for cabling etc., must not be left open for extended periods as fauna such as tortoises will fall in and become trapped. Any open trenches must be checked regularly for trapped fauna.</li> </ol>	

IMPACT	FAUNA This section deals with faunal issues and actions that need to be implemented during construction	RESPONSIBILITY
PHASE	CONSTRUCTION	MC, EO, ECO
<b>ENVIRONMENTAL MANAGEMENT PROGRAMME</b>		
	<p>9. The illegal collection, hunting or harvesting of any plants or animals at the site must be strictly forbidden. Personnel must not be allowed to wander off the construction site.</p> <p>10. No fires must be allowed within the site as there is a risk of runaway veld fires.</p> <p>11. No dogs or cats must be allowed on site apart from that of the landowners.</p> <p>12. If any parts of site such as construction camps must be lit at night, this must be done with low-UV type lights (such as most LEDs) as far as practically possible, which do not attract insects and which must be directed downwards.</p> <p>13. All construction vehicles must adhere to a low speed limit (40km/h for cars and 30km/h for trucks) to avoid collisions with susceptible species such as snakes and tortoises and rabbits or hares.</p> <p>14. All personnel must undergo environmental induction with regards to fauna and in particular awareness about not harming or collecting species such as snakes, tortoises and snakes which are often persecuted out of fear or superstition.</p>	

3.4.11 Avifauna

**Table 19: Avifauna**

IMPACT	AVIFAUNA This section deals with avifaunal issues and actions that need to be implemented during construction	RESPONSIBILITY
PHASE	CONSTRUCTION	MC, EO, ECO
<b>ENVIRONMENTAL MANAGEMENT PROGRAMME</b>		
<b>MITIGATION / METHOD STATEMENT</b>	<ol style="list-style-type: none"> <li>1. Ensure that key areas of conservation importance and sensitivity are avoided.</li> <li>2. Implement appropriate working practices to protect sensitive habitats.</li> <li>3. Provide adequate briefing for site personnel and, in particularly sensitive locations, employing an on-site ecologist during construction.</li> <li>4. Implement an agreed post-development monitoring programme.</li> <li>5. Mark overhead cables using deflectors where required.</li> <li>6. Time construction to avoid sensitive periods, where possible.</li> <li>7. Implement habitat enhancement for species using the site.</li> </ol>	
<b>SPECIFIC MITIGATION MEASURES</b>		
	<ol style="list-style-type: none"> <li>8. Restrict the construction activities to the construction footprint area.</li> <li>9. Do not allow any access to the remainder of the property during the construction period.</li> <li>10. Maximum use must be made of existing access roads and the construction of new roads must be kept to a minimum.</li> <li>11. A 300m exclusion zone must be implemented around the existing water points and pans where no construction activity or disturbance must take place.</li> <li>12. A 1.2km exclusion zone must be implemented around the active Martial Eagle nest on the Aries – Helios 400kV line at -30.517644 19.550840 in the power line study area where no construction activity or disturbance must take place.</li> </ol>	

<b>IMPACT</b>	<b>AVIFAUNA</b> This section deals with avifaunal issues and actions that need to be implemented during construction	<b>RESPONSIBILITY</b>
<b>PHASE</b>	<b>CONSTRUCTION</b>	<b>MC, EO, ECO</b>
<b>ENVIRONMENTAL MANAGEMENT PROGRAMME</b>		
	13. The recommendations of the specialist ecological study must be strictly adhered to, especially as far as rehabilitation of vegetation is concerned.	

### 3.4.12 Air Quality

**Table 20:** Air quality

<b>IMPACT</b>	<b>AIR QUALITY</b> This table deals with mitigation measures to prevent air pollution	<b>RESPONSIBILITY</b>
<b>PHASE</b>	<b>CONSTRUCTION</b>	<b>MC, EO, ECO</b>
<b>ENVIRONMENTAL MANAGEMENT PROGRAMME</b>		
<b>MITIGATION / METHOD STATEMENT</b>	<b>Dust control</b> <ol style="list-style-type: none"> <li>1. Wheel washing and damping down of un-surfaced and un-vegetated areas must be undertaken if required.</li> <li>2. Retention of vegetation where possible will reduce dust travel.</li> <li>3. Excavations and other clearing activities must only be done during agreed working times and permitting weather conditions to avoid drifting of sand and dust into neighbouring areas.</li> <li>4. Damping down of all exposed soil surfaces with a water bowser or sprinklers when necessary to reduce dust.</li> <li>5. The Contractor must be responsible for dust control on site to ensure no nuisance is caused to the neighbouring communities.</li> </ol>	

IMPACT	AIR QUALITY	RESPONSIBILITY
	<p>This table deals with mitigation measures to prevent air pollution</p> <p>6. A speed limit of 40km/h for cars and 30km/h for trucks must not be exceeded on site.</p> <p>7. Any complaints or claims emanating from the lack of dust control must be attended to immediately by the Contractor.</p> <p>8. Any dirt roads that are utilised by the workers must be regularly maintained to ensure that dust levels are controlled.</p> <p><b>Odour control</b></p> <p>9. Regular servicing of vehicles in order to limit gaseous emissions.</p> <p>10. Regular servicing of on-site toilets to avoid potential odours.</p> <p>11. Allocated cooking areas must be provided.</p> <p>12. The contractor must make alternative arrangements (other than fires) for cooking and/ or heating requirements. LP gas cookers must be used provided that all safety regulations are followed.</p> <p><b>Fire prevention</b></p> <p>13. No open fires must be allowed on site under any circumstance. All cooking must be done in demarcated areas that are safe and cannot cause runaway fires.</p> <p>14. The Contractor must have operational fire-fighting equipment available on site at all times. The level of firefighting equipment must be assessed and evaluated through a typical risk assessment process.</p>	

3.4.13 Noise and Vibrations

**Table 21:** Noise and Vibrations

<b>IMPACT</b>	<b>NOISE</b> This section deals with noise issues and actions that need to be implemented during construction	<b>RESPONSIBILITY</b>
<b>PHASE</b>	<b>CONSTRUCTION</b>	<b>MC, EO, ECO</b>
<b>ENVIRONMENTAL MANAGEMENT PROGRAMME</b>		
<b>MITIGATION / METHOD STATEMENT</b>	<ol style="list-style-type: none"> <li>1. The construction phase must aim to adhere to the relevant noise regulations and limit noise to within standard working hours in order to reduce disturbance of dwellings in close proximity to the development.</li> <li>2. The construction crew must abide by the local by-laws regarding noise.</li> <li>3. Ensure that noise as a component is included in the induction of employees and contractors, and how their activities and actions can impact on residents in the area (reverse alarms and reversing close to dwellings, driving fast past residential dwellings at night, maintenance of equipment). All contractors and employees must receive this induction.</li> <li>4. Construction site yards, workshops, concrete batching plants, and other noisy fixed facilities must be located well away from noise sensitive areas. Once the proposed final layouts are made available by the contractor(s), the sites must be evaluated in detail and specific measures designed into the system</li> <li>5. Truck traffic must be routed away from noise sensitive areas, where possible.</li> <li>6. Noise levels must be kept within acceptable limits.</li> <li>7. Noisy operations must be combined so that they occur where possible at the same time.</li> <li>8. Construction activities are to be confined to reasonable hours during the day and early evening. Night-time activities near noise sensitive areas must not be permitted.</li> <li>9. Construction workers to wear necessary ear protection gear.</li> <li>10. Noise from labourers must be controlled.</li> </ol>	

IMPACT	<b>NOISE</b> <b>This section deals with noise issues and actions that need to be implemented during construction</b>	RESPONSIBILITY
<b>PHASE</b>	<b>CONSTRUCTION</b>	<b>MC, EO, ECO</b>
<b>ENVIRONMENTAL MANAGEMENT PROGRAMME</b>		
	<p>11. Noise suppression measures must be applied to all construction equipment. Construction equipment must be kept in good working order and where appropriate fitted with silencers which are kept in good working order. Should the vehicles or equipment not be in good working order, the contractor must be instructed to remove the offending vehicle or machinery from site.</p> <p>12. The contractor must take measures to discourage labourers from loitering in the area and causing noise disturbance. Where possible labour must be transported to and from the site by the contractor or his Sub-Contractors by the contractors own transport.</p> <p>13. Implementation of enclosure and cladding of processing plants.</p> <p>14. Apply regular and thorough maintenance schedules to equipment and processes. An increase in noise emission levels very often is a sign of the imminent mechanical failure of a machine.</p> <p>15. Route construction traffic as far as practically possible from potentially sensitive receptors.</p> <p>16. Ensure a good working relationship between the developer and all potentially sensitive receptors. Communication channels must be established to ensure prior notice to the sensitive receptor if work is to take place close to them. Information that must be provided to the potential sensitive receptor(s) include:</p> <ul style="list-style-type: none"> <li>▪ Proposed working times;</li> <li>▪ how long the activity is anticipated to take place;</li> <li>▪ what is being done, or why the activity is taking place;</li> <li>▪ contact details of a responsible person where any complaints can be lodged should there be an issue of concern.</li> </ul> <p>17. When working near (within 500 meters) to a potential sensitive receptor(s), limit the number of simultaneous activities to the minimum as far as possible;</p>	

IMPACT	<b>NOISE</b> <b>This section deals with noise issues and actions that need to be implemented during construction</b>	RESPONSIBILITY
<b>PHASE</b>	<b>CONSTRUCTION</b>	<b>MC, EO, ECO</b>
<b>ENVIRONMENTAL MANAGEMENT PROGRAMME</b>		
	<p>18. When working in very close proximity to potentially sensitive receptors, coordinate the working time with periods when the receptors are not at home where possible. An example would be to work within the 08:00 to 17:00 time-slot to minimize the significance of the impact because:</p> <ul style="list-style-type: none"> <li>▪ Potential receptors are most likely at school or at work, minimizing the probability of an impact happening;</li> <li>▪ Normal daily activities will generate other noises that would most likely mask construction noises, minimizing the probability of an impact happening.</li> </ul> <p>19. Notify potentially sensitive receptors about work to take place at least 2 days before the activity in the vicinity (within 500 meters) of the NSD is to start. Following information to be presented in writing:</p> <ul style="list-style-type: none"> <li>▪ Description of Activity to take place;</li> <li>▪ Estimated duration of activity;</li> <li>▪ Working hours;</li> </ul> <p>20. Contact details of responsible party.</p> <p>21. Where possible construction work must be undertaken during normal working hours (06H00 – 22H00), from Monday to Saturday; If agreements can be reached (in writing) with all the surrounding (within a 2,000m distance) potentially sensitive receptors, these working hours can be extended.</p> <p>22. The developer must investigate any reasonable and valid noise complaint if registered by a receptor staying within 2,000m from location where construction activities are taking place or operational wind turbine.</p> <p>23. When any noise complaints are received, noise monitoring must be conducted at the complainant, followed by feedback regarding noise levels measured.</p> <p>24. Reduce the noise impact during the construction phase by:</p>	



<b>IMPACT</b>	<b>NOISE</b> This section deals with noise issues and actions that need to be implemented during construction	<b>RESPONSIBILITY</b>
<b>PHASE</b>	<b>CONSTRUCTION</b>	<b>MC, EO, ECO</b>
<b>ENVIRONMENTAL MANAGEMENT PROGRAMME</b>		
	<ul style="list-style-type: none"> <li>▪ Using the smallest/quietest equipment for the particular purpose. For modelling purposes the noise emission characteristics of large earth-moving equipment (typically of mining operations) were used, that would most likely over-estimate the noise levels. The use of smaller equipment therefore would have a significantly lower noise impact;</li> <li>▪ Ensuring that equipment is well-maintained and fitted with the correct and appropriate noise abatement measures.</li> </ul>	
<b>SPECIFIC MITIGATION MEASURES</b>		
	<p>25. Due to the low ambient sound levels, it is highly recommended that no construction activities are allowed within 500m from occupied dwellings at night.</p> <p>26. No access roads (or grid lines) must be developed closer than 250m from dwellings that will be occupied during the construction period.</p> <p>27. The developer must implement a line of communication (i.e. a help line where complaints could be lodged). All potential sensitive receptors must be made aware of these contact numbers.</p>	

### 3.4.14 Energy Use

**Table 22:** Energy use

<b>IMPACT</b>	<b>ENERGY USE</b> This section deals with energy use and actions that need to be implemented during construction	<b>RESPONSIBILITY</b>
<b>PHASE</b>	<b>CONSTRUCTION</b>	<b>MC, EO, ECO</b>
<b>ENVIRONMENTAL MANAGEMENT PROGRAMME</b>		
<b>MITIGATION / METHOD STATEMENT</b>	<ol style="list-style-type: none"> <li>1. Energy saving lighting must be implemented across the board.</li> <li>2. Minimal lighting, while maintaining health and safety regulations, must be kept on during the night operations.</li> <li>3. Equipment not in use must be switched off and unplugged to save on unnecessary energy costs and carbon footprint.</li> </ol>	

### 3.4.15 Employment

**Table 23:** Employment

<b>IMPACT</b>	<b>EMPLOYMENT</b> This section deals with employment issues and actions that need to be implemented during construction	<b>RESPONSIBILITY</b>
<b>PHASE</b>	<b>CONSTRUCTION</b>	<b>PM, MC, EO, CLO</b>
<b>ENVIRONMENTAL MANAGEMENT PROGRAMME</b>		
<b>MITIGATION / METHOD STATEMENT</b>	<p><b>Labour</b></p> <ol style="list-style-type: none"> <li>1. The use of labour intensive construction measures must be used where appropriate.</li> <li>2. Training of labour to benefit individuals.</li> </ol>	

IMPACT	EMPLOYMENT This section deals with employment issues and actions that need to be implemented during construction	RESPONSIBILITY
PHASE	CONSTRUCTION	PM, MC, EO, CLO
<b>ENVIRONMENTAL MANAGEMENT PROGRAMME</b>		
	<p><b>Recruitment Plan</b></p> <ol style="list-style-type: none"> <li>3. The majority of unskilled labourers must be drawn from the local market and where possible use must be made of local semiskilled and skilled personnel.</li> <li>4. Local suppliers to be used where possible.</li> <li>5. The Project Manager must ensure that all staff working on the proposed project are in possession of a South African Identity Document or a relevant work permit.</li> <li>6. Ensure adequate advertising in the project community areas, local papers for labour. Adverts are to be placed in each area where the public meetings were conducted.</li> <li>7. Local community key stakeholders must be utilised to source labour where possible.</li> <li>8. The recruitment process must be equitable and transparent. A concerted effort will be made to guard against nepotism and/or any form of favouritism during the process</li> <li>9. The recruitment of skilled labour will follow standard advertising procedures in national newspapers and interview based selection</li> <li>10. A record of official complaints by employees is to be maintained and a grievance mechanism must be put in place for all employees.</li> <li>11. Drafting legal and binding enforcements stipulating that the majority of the unskilled positions in the project be allocated to local labourers</li> <li>12. Where possible, subcontract to local construction companies</li> <li>13. Consultation with local authorities is essential so as to manage job creation expectations and ensure that all eligible workers in the primary study area are informed of the opportunities.</li> <li>14. The project proponent must provide learnerships to locals apart from the on-the-job training for employed individuals. This will address the issues of the reduced employment and skills development opportunities</li> </ol>	

IMPACT	EMPLOYMENT This section deals with employment issues and actions that need to be implemented during construction	RESPONSIBILITY
PHASE	CONSTRUCTION	PM, MC, EO, CLO
<b>ENVIRONMENTAL MANAGEMENT PROGRAMME</b>		
	<p>by increasing the chances of local labour to receive employment when a similar development is established in the region.</p> <p>15. Where possible, ensure that the local community members are prioritised for the allocation of the created jobs.</p> <p>16. Contracts ensuring that on-the-job training is included and enforced as a condition for the development of this project.</p> <p>17. To improve the chances of skills development during the construction phase, contractors are encouraged to provide learnerships and encourage further knowledge sharing.</p> <p>18. It is advisable that investment into skills development of the local community occurs prior the start of project's operations. As such it is recommended that training provided by the project proponent must not only be limited to the people receiving formal employment, but also those who desire to receive such skills. This will ensure that the local labour has a competitive advantage over job-seekers from outside areas.</p> <p>19. Contracts ensuring that knowledge sharing and on-the-job training must be enforced as a condition for the development of the project.</p> <p>20. To ensure that skills are adequately acquired, additional training programmes need to be held during the construction phase to prepare the identified community members to be employed at the next phase, i.e. operational.</p> <p>21. Initiating the education campaign among the local community (in partnership with the community members already active in the area) focusing on alcohol abuse, drug abuse, HIV/AIDS, STDs, etc. prior to the start of construction and maintaining this campaign throughout the project's duration.</p>	

<b>IMPACT</b>	<b>EMPLOYMENT</b> This section deals with employment issues and actions that need to be implemented during construction	<b>RESPONSIBILITY</b>
<b>PHASE</b>	<b>CONSTRUCTION</b>	<b>PM, MC, EO, CLO</b>
<b>ENVIRONMENTAL MANAGEMENT PROGRAMME</b>		
	<p>22. Developers must be open to local recruitment processes and be willing to offer some skills transfer during this phase of the project to ensure maximum local labour procurement.</p> <p>23. Recruitment must be done following a transparent approach and adequately communicated in the area to limit the chances of people staying for longer periods in hope of finding a job.</p>	

*\*Please note: The recruitment plan may slightly change from time to time as the main construction contractors have not been selected.*

3.4.16 Occupational Health and Safety

**Table 24:** Occupational Health and Safety

<b>IMPACT</b>	<b>HEALTH AND SAFETY</b> This section deals with health and safety and actions that need to be implemented during construction	<b>RESPONSIBILITY</b>
<b>PHASE</b>	<b>CONSTRUCTION</b>	<b>MC, EO, ECO, CLO</b>
<b>ENVIRONMENTAL MANAGEMENT PROGRAMME</b>		
<b>MITIGATION / METHOD STATEMENT</b>	<p><b>Worker safety</b></p> <ol style="list-style-type: none"> <li>1. Implementation of safety measures, work procedures and first aid must be implemented on site.</li> <li>2. Workers must be thoroughly trained in using potentially dangerous equipment.</li> <li>3. Contractors must ensure that all equipment is maintained in a safe operating condition.</li> <li>4. A safety officer must be appointed.</li> <li>5. A record of health and safety incidents must be kept on site.</li> <li>6. Any health and safety incidents must be reported to the Project Manager immediately.</li> <li>7. First aid facilities must be available on site at all times and a number of employees trained to carry out first aid procedures.</li> <li>8. Workers have the right to refuse work in unsafe conditions.</li> <li>9. The Contractor must take all the necessary precautions against the spreading of disease such as measles, foot and mouth, etc. especially under livestock.</li> <li>10. A record must be kept of drugs administered or precautions taken and the time and dates when this was done. This can then be used as evidence in court must any claims be instituted against the Project Company or the Contractor.</li> <li>11. The contractor must ensure that all construction workers are well educated about HIV/ AIDS and the risks surrounding this disease. The location of the local clinic where more information and counselling is offered must be indicated to workers.</li> </ol>	

IMPACT	<b>HEALTH AND SAFETY</b> This section deals with health and safety and actions that need to be implemented during construction	RESPONSIBILITY
PHASE	CONSTRUCTION	MC, EO, ECO, CLO
<b>ENVIRONMENTAL MANAGEMENT PROGRAMME</b>		
	<p>12. Material stockpiles or stacks must be stable and well secured to avoid collapse and possible injury to site workers / local residents.</p> <p>13. Material stockpiles or stacks must be stable and well secured to avoid collapse and possible injury to site workers / local residents.</p> <p><b>Worker facilities</b></p> <p>14. Eating areas must be regularly serviced and cleaned to ensure the highest possible standards of hygiene and cleanliness.</p> <p>15. Fires are not to be allowed outside controlled areas.</p> <p>16. Ablution facilities must be well maintained.</p> <p><b>Hazardous substances</b></p> <p>17. Working areas must be provided with adequate ventilation and dust/fume extraction systems to ensure that inhalation exposure levels for potentially corrosive, oxidizing, reactive or siliceous substances are maintained and managed at safe levels.</p> <p><b>Electrical Safety and isolation</b></p> <p>18. Use of electrical safety devices on all final distribution circuits and appropriate testing schedules applied to such safety systems.</p> <p>19. All sources of hazardous energy or hazardous substances must have written procedures for isolation, identifying how the system, plant or equipment can be made and kept safe.</p> <p><b>Physical Hazards</b></p>	

<b>IMPACT</b>	<b>HEALTH AND SAFETY</b> This section deals with health and safety and actions that need to be implemented during construction	<b>RESPONSIBILITY</b>
<b>PHASE</b>	<b>CONSTRUCTION</b>	<b>MC, EO, ECO, CLO</b>
<b>ENVIRONMENTAL MANAGEMENT PROGRAMME</b>		
	<p>20. Geotechnical safety - All structures must be planned, designed and operated such that the geotechnical risks are appropriately managed.</p> <p><b>Machine and Equipment</b></p> <p>21. Use must be made of contrast colouring on equipment/machinery including the provision of reflective markings to enhance visibility.</p> <p>22. Use must be made of moving equipment/machinery equipped with improved operator sight lines.</p> <p>23. Workers must be issued with high visibility clothing.</p> <p>24. Use must be made of reflective markings on structures, traffic junctions, and other areas with a potential for accidents.</p> <p>25. Safety barriers must be installed in high risk locations.</p> <p><b>Fitness for work</b></p> <p>26. Shift management systems must minimize risk of fatigue. Establish alcohol and other drug policy for the operation.</p> <p><b>Travel and remote site health</b></p> <p>27. Develop programs to prevent both chronic and acute illnesses through appropriate sanitation and vector control systems.</p> <p><b>Protective gear</b></p>	



IMPACT	HEALTH AND SAFETY This section deals with health and safety and actions that need to be implemented during construction	RESPONSIBILITY
PHASE	CONSTRUCTION	MC, EO, ECO, CLO
<b>ENVIRONMENTAL MANAGEMENT PROGRAMME</b>		
	<p>28. Personal Protective Equipment (PPE) must be made available to all construction staff and must be compulsory. Hard hats and safety shoes must be worn at all times and other PPE worn where necessary i.e. dust masks, ear plugs etc.</p> <p>29. No person is to enter the site without the necessary PPE.</p> <p><b>Site safety</b></p> <p>30. The construction camp must remain fenced for the entire construction period.</p> <p>31. Potentially hazardous areas are to be demarcated and clearly marked.</p> <p>32. Adequate warning signs of hazardous working areas must be in place.</p> <p>33. Emergency numbers for local police and fire department etc. must be placed in a prominent area.</p> <p>34. Suitable conspicuous warning signs in English and all other applicable languages must be placed at all entrances to the site.</p> <p>35. All speed limits must be adhered to.</p> <p><b>Construction equipment safety</b></p> <p>36. All equipment used for construction must be in good working order with up to date maintenance records.</p> <p><b>Hazardous Material Storage</b></p> <p>37. All storage tanks containing hazardous materials (fuel) must be placed in bunded containment areas with sealed surfaces. The bund walls must be high enough to contain 110% of the total volume of the stored hazardous material. These areas must be roofed to avoid contamination of stormwater.</p> <p>38. Material Safety Data Sheets (MSDS) which contain the necessary information pertaining to a specific hazardous substance must be present for all hazardous materials stored on the site.</p>	

<b>IMPACT</b>	<b>HEALTH AND SAFETY</b> This section deals with health and safety and actions that need to be implemented during construction	<b>RESPONSIBILITY</b>
<b>PHASE</b>	<b>CONSTRUCTION</b>	<b>MC, EO, ECO, CLO</b>
<b>ENVIRONMENTAL MANAGEMENT PROGRAMME</b>		
	<p><b>Procedure in the event of a petrochemical spill</b></p> <p>39. A spill kit needs to be kept on site to address any unforeseen spillages.</p> <p>40. The individual responsible for or who discovers the petrochemical spill must report the incident to the Project Manager, Contractor or ECO.</p> <p>41. The problem must be assessed and the necessary actions required will be undertaken.</p> <p>42. The immediate response must be to contain the spill.</p> <p>43. The source of the spill must be identified, controlled, treated or removed wherever possible.</p> <p><b>Fire management</b></p> <p>44. Firefighting equipment must be present on site at all times.</p> <p>45. All construction staff must be trained in fire hazard control and firefighting techniques.</p> <p>46. All flammable substances must be stored in dry areas which do not pose an ignition risk to the said substances.</p> <p>47. No open fires will be allowed on site.</p> <p>48. Smoking must only be permitted in demarcated areas.</p> <p><b>Safety of surrounding residents</b></p> <p>49. All I &amp; AP's must be notified in advance of any known potential risks associated with the construction site and the activities on it. Examples of these are:</p> <ul style="list-style-type: none"> <li>▪ Blasting</li> <li>▪ Earthworks / earthmoving machinery on steep slopes above houses / infrastructure</li> </ul>	

<b>IMPACT</b>	<b>HEALTH AND SAFETY</b> This section deals with health and safety and actions that need to be implemented during construction	<b>RESPONSIBILITY</b>
<b>PHASE</b>	<b>CONSTRUCTION</b>	<b>MC, EO, ECO, CLO</b>
<b>ENVIRONMENTAL MANAGEMENT PROGRAMME</b>		
	<ul style="list-style-type: none"> <li>▪ Risk to residence along haulage roads / access routes.</li> </ul> <p><b>Emergency evacuation plan</b></p> <p>50. Upon completion of the construction phase, an emergency evacuation plan must be drawn up to ensure the safety of the staff and surrounding land users in the case of an emergency.</p> <p>51. All staff must undergo safety training.</p> <p><b>Maintenance</b></p> <p>52. The substations, corridor and surrounding areas are to be regularly maintained. A maintenance schedule must be drawn up and records of all maintenance kept.</p>	

3.4.17 Security

**Table 25: Security**

<b>IMPACT</b>	<b>SECURITY</b> This section deals with security and actions that need to be implemented during construction	<b>RESPONSIBILITY</b>
<b>PHASE</b>	<b>CONSTRUCTION</b>	<b>MC, EO, ECO</b>
<b>ENVIRONMENTAL MANAGEMENT PROGRAMME</b>		
<b>MITIGATION / METHOD STATEMENT</b>	<ol style="list-style-type: none"> <li>1. A security company must be employed to guard the construction site and monitor access. This company must also be utilised for the operation phase.</li> <li>2. Labour must be transported to and from the site to discourage loitering in adjacent areas and a possible increase in crime or disturbance.</li> <li>3. Unsocial activities such as consumption or illegal selling of alcohol, drug utilisation or selling and prostitution on site must be prohibited. Disciplinary or criminal action must be taken against any persons found to be engaged in such activities.</li> <li>4. Only pre-approved staff must be permitted to stay in the staff accommodation where staff accommodation is provided.</li> <li>5. The site must be fenced, where necessary to prevent any loss or injury to persons during the construction phase.</li> <li>6. No alcohol / drugs to be present on site.</li> <li>7. No firearms allowed on site or in vehicles transporting staff to / from site (unless used by security personnel).</li> <li>8. Construction staff is to make use of the facilities provided for them, as opposed to ad-hoc alternatives (e.g. fires for cooking, the use of surrounding bush as a toilet facility are forbidden).</li> <li>9. Trespassing on private / commercial properties adjoining the site is forbidden.</li> <li>10. All employees must undergo the necessary safety training and wear the necessary protective clothing.</li> </ol>	

<b>IMPACT</b>	<b>SECURITY</b> This section deals with security and actions that need to be implemented during construction	<b>RESPONSIBILITY</b>
<b>PHASE</b>	<b>CONSTRUCTION</b>	<b>MC, EO, ECO</b>
<b>ENVIRONMENTAL MANAGEMENT PROGRAMME</b>		
	11. The site must be secured in order to reduce the opportunity for criminal activity in the locality of the construction site.	

#### 3.4.18 Social Environment

**Table 26:** Social Environment

<b>IMPACT</b>	<b>SOCIAL ENVIRONMENT</b> This section deals with social environment and actions that need to be implemented during construction	<b>RESPONSIBILITY</b>
<b>PHASE</b>	<b>CONSTRUCTION</b>	<b>MC, EO, ECO, CLO</b>
<b>ENVIRONMENTAL MANAGEMENT PROGRAMME</b>		
<b>MITIGATION / METHOD STATEMENT</b>	<ol style="list-style-type: none"> <li>1. All contact with the affected parties must be courteous at all times. The rights of the affected parties must be respected at all times.</li> <li>2. A complaints register must be kept on site. Details of complaints must be incorporated into the audits as part of the monitoring process. This must be in carbon copy format, with numbered pages. Any missing pages must be accounted for by the Contractor.</li> <li>3. Damage to infrastructure must not be tolerated and any damage must be rectified immediately by the Contractor. A record of all damage and remedial actions must be kept on site.</li> <li>4. Care must be taken not to damage irrigation equipment, lines, channels and crops.</li> </ol>	
<b>SPECIFIC MITIGATION MEASURES</b>		

IMPACT	<b>SOCIAL ENVIRONMENT</b> This section deals with social environment and actions that need to be implemented during construction	RESPONSIBILITY
PHASE	CONSTRUCTION	MC, EO, ECO, CLO
<b>ENVIRONMENTAL MANAGEMENT PROGRAMME</b>		
	<ol style="list-style-type: none"> <li>5. Minimise the possibility of attracting a number of people in search for employment in the vicinity of the farms by ensuring clear communication regarding the project.</li> <li>6. Engage with property owners prior to the developing of the substations and erection of the power line to ensure that the expectations (rules) of the farmers regarding access to farms are understood and effectively adhered to.</li> <li>7. Construction workers must be thoroughly informed of the rules made by farmers and be made to understand the accompanying consequences.</li> <li>8. Implement controlled access to farm properties where the power line and substations will be built and ensure that the construction workers are on site during reasonable working hours.</li> <li>9. Ensure clear communication of the project information and effective public participation processes to minimise the influx of migrant job seekers.</li> <li>10. Movement of construction workers on and off construction site must be closely monitored and managed.</li> <li>11. Ensure the mitigation measures proposed to limit the influx of people and the prolonged negative effects of the migrants staying in the community after the construction are implemented.</li> <li>12. Engage with the local authorities to inform them on the timeframes of the project.</li> <li>13. Where possible, assist the local municipality in ensuring that the quality of the social and economic infrastructure does not deteriorate by making use of social responsibility allocations.</li> <li>14. Engage with the local authorities to inform them on the timeframes of the project and possible risks from a service delivery perspective.</li> <li>15. Engage with the local municipality to discuss the potential impact on local road quality, social infrastructure, and demand for accommodation, as well as possible mitigation measures.</li> <li>16. Employ labour-intensive methods as far as feasible in the construction phase.</li> </ol>	

IMPACT	<b>SOCIAL ENVIRONMENT</b> This section deals with social environment and actions that need to be implemented during construction	RESPONSIBILITY
PHASE	CONSTRUCTION	MC, EO, ECO, CLO
<b>ENVIRONMENTAL MANAGEMENT PROGRAMME</b>		
	<ul style="list-style-type: none"> <li>17. Make condoms available to employees and all contractor workers for free.</li> <li>18. Introduce alcohol testing on a weekly basis for construction workers.</li> <li>19. Developing a Code of Conduct for all employees related to the project, which includes no tolerance of activities such as alcohol and drug abuse.</li> <li>20. The project developer must appoint a service provider or local NGO to develop, implement and manage an STI &amp; HIV/AIDS prevention programme and other educational campaigns. The service provider or NGO must specialise in these fields and must have sufficient experience with similar work.</li> <li>21. The prevention programme and educational campaigns must extend to the local community and must pay special attention to vulnerable groups such as women and youth.</li> <li>22. The project developer must engage with other companies planning to establish renewable energy facilities in the area to optimise their efforts in educating the local community and implementing preventative programmes.</li> <li>23. Implement mitigation measures recommended by the other relevant specialists (i.e. visual and noise).</li> </ul>	

3.4.19 Heritage

Table 27: Heritage

IMPACT	<b>CULTURAL AND HERITAGE ARTEFACTS</b> This section deals with the impact that the new development has on potential archaeological artefacts on the site	RESPONSIBILITY
PHASE	CONSTRUCTION	MC, EO, ECO, CLO
<b>ENVIRONMENTAL MANAGEMENT PROGRAMME</b>		
<b>MITIGATION / METHOD STATEMENT</b>	<ol style="list-style-type: none"> <li>1. Any finds must be reported to the nearest National Monuments office to comply with the National Heritage Resources Act (Act No 25 of 1999) and to DEA.</li> <li>2. Any finds must be reported to the nearest National Monuments office to comply with the National Heritage Resources Act (Act No 25 of 1999) and to DEA.</li> <li>3. Local museums as well as the South African Heritage Resource Agency (SAHRA) must be informed if any artefacts are uncovered in the affected area.</li> <li>4. The contractor must ensure that his workforce is aware of the necessity of reporting any possible historical or archaeological finds to the ECO so that appropriate action can be taken.</li> <li>5. Any discovered artefacts must not be removed under any circumstances. Any destruction of a site can only be allowed once a permit is obtained and the site has been mapped and noted. Permits must be obtained from the South African Heritage Resources Association (SAHRA) must the proposed site affect any world heritage sites or if any heritage sites are to be destroyed or altered.</li> <li>6. Should any archaeological sites / graves be uncovered during construction, their existence must be reported to the Project Company and MC immediately.</li> </ol>	
<b>SPECIFIC MITIGATION MEASURES</b>		
	<b>Palaeontology</b> <ol style="list-style-type: none"> <li>7. Prior to construction a detailed palaeontology study must be conducted to assess the value and importance of fossils in the development area and the effect of the proposed development on the palaeontological heritage. This will consist of a Phase 1 field-based assessment which will be</li> </ol>	



<b>IMPACT</b>	<b>CULTURAL AND HERITAGE ARTEFACTS</b> This section deals with the impact that the new development has on potential archaeological artefacts on the site	<b>RESPONSIBILITY</b>
<b>PHASE</b>	<b>CONSTRUCTION</b>	<b>MC, EO, ECO, CLO</b>
<b>ENVIRONMENTAL MANAGEMENT PROGRAMME</b>		
	<p>undertaken by a professional palaeontologist. The purpose of the detailed Report is to elaborate on the issues and potential impacts identified during the initial study undertaken for the BA. This will be achieved by undertaking site visits and research in the site-specific study area as well as a comprehensive assessment of the impacts identified during the BA. The report must be submitted to SAHRA before the commencement of any development-related activities.</p> <p><b>Heritage</b></p> <ol style="list-style-type: none"> <li>8. Monitor find spot areas if construction is going to take place through them.</li> <li>9. A management plan for the heritage resources needs to be implemented during construction and operations.</li> <li>10. Possible surface collections for sites with a medium to high significance as well as conducting a watching brief by heritage practitioner is to be undertaken during the construction phase.</li> <li>11. A Fossil Finds Procedure must be developed and incorporated into the EMP prior to construction.</li> <li>12. If any evidence of archaeological sites or remains (e.g. remnants of stone-made structures, indigenous ceramics, bones, stone artefacts, ostrich eggshell fragments, charcoal and ash concentrations), fossils or other categories of heritage resources are found during the proposed development, SAHRA APM Unit (Natasha Higgitt/Phillip Hine 021 462 5402) must be alerted. If unmarked human burials are uncovered, the SAHRA Burial Grounds and Graves (BGG) Unit (Thingahangwi Tshivhase/Mimi Seetelo 012 320 8490), must be alerted immediately. A professional archaeologist or palaeontologist, depending on the nature of the finds, must be contracted as soon as possible to inspect the findings. If the newly discovered heritage resources prove to be of archaeological or palaeontological significance, a Phase 2 rescue operation may be required subject to permits issued by SAHRA.</li> </ol>	

<b>IMPACT</b>	<b>CULTURAL AND HERITAGE ARTEFACTS</b> This section deals with the impact that the new development has on potential archaeological artefacts on the site	<b>RESPONSIBILITY</b>
<b>PHASE</b>	<b>CONSTRUCTION</b>	<b>MC, EO, ECO, CLO</b>
<b>ENVIRONMENTAL MANAGEMENT PROGRAMME</b>		
	13. All stakeholders and key personnel must undergo an archaeological induction course, as part of their overall training. The course must highlight the appropriate communication channels to managers and educate workers with regard to recognising artefacts, features and significant sites. Project manager must ensure that the training and capabilities of the Contractor's site staff are adequate to carry out the designated tasks. Use must be made of environmental awareness posters on site.	

3.4.20 Visual Impact

**Table 28:** Visual Impact

IMPACT	VISUAL This section deals with visual issues and actions that need to be implemented during construction	RESPONSIBILITY
PHASE	CONSTRUCTION	MC, EO, ECO
<b>ENVIRONMENTAL MANAGEMENT PROGRAMME</b>		
<b>MITIGATION / METHOD STATEMENT</b>	<p><b>General</b></p> <ol style="list-style-type: none"> <li>1. Construction activities must not occur at night and lighting must only be erected where absolutely necessary.</li> <li>2. Construction traffic must stick to designated routes or access roads.</li> <li>3. Construction areas are to be kept clean and tidy.</li> <li>4. Measures must be taken to suppress dust arising from construction activities.</li> <li>5. Labour being transported to the site must take cognisance of litter and waste concerns.</li> <li>6. Equipment being transported to the site must be covered with tarps.</li> <li>7. Topsoil stockpiles must be well managed and seeded when possible if not utilised within three months.</li> <li>8. It is recommended that equipment be stored discreetly so as not to increase visual impacts.</li> <li>9. Construction must be conducted in the shortest possible time in order to reduce visual impacts.</li> </ol>	
<b>SPECIFIC MITIGATION MEASURES</b>		
	<ol style="list-style-type: none"> <li>10. Carefully plan to avoid any delays or extensions to the construction period.</li> <li>11. Minimise vegetation clearing and rehabilitate cleared areas as soon as possible.</li> <li>12. Vegetation clearing take place in a phased manner.</li> <li>13. Maintain a neat construction site by removing rubble and waste materials regularly.</li> <li>14. Make use of existing gravel access roads where possible.</li> <li>15. Limit the number of vehicles and trucks travelling to and from the proposed site, where possible.</li> </ol>	

	<p>16. If dust plumes become an issue, dust suppression techniques must be implemented on gravel access roads utilised during construction, where possible.</p> <p>17. Ensure that all soil stockpiles are covered in order to reduce dust.</p> <p>18. Establish erosion control measures on areas which will be exposed for long periods of time. This is to reduce the potential impact heavy rains must have on the bare soil.</p>	
--	---	--

### 3.5 Operation Phase

#### 3.5.1 Construction Site Decommissioning

**Table 29:** Construction Site Decommissioning

<b>IMPACT</b>	<b>CONSTRUCTION SITE DECOMMISSIONING</b> This section deals with the demolishing of the construction camp and the actions that need to be implemented	<b>RESPONSIBILITY</b>
<b>PHASE</b>	<b>OPERATION</b>	<b>MC, ECO, EO, ESKOM</b>
<b>ENVIRONMENTAL MANAGEMENT PROGRAMME</b>		
<b>MITIGATION / METHOD STATEMENT</b>	<p><b>Removal of equipment</b></p> <ol style="list-style-type: none"> <li>1. All structures comprising the construction camp are to be removed from site.</li> <li>2. The area that previously housed the construction camp is to be checked for spills of substances such as oil, paint etc., and these must be cleaned up.</li> <li>3. All hardened surfaces within the construction camp area must be ripped, all imported materials removed, and the area must be top soiled and regressed using the guidelines set out in the re-vegetation plan that forms part of this document.</li> </ol> <p><b>Temporary services</b></p> <ol style="list-style-type: none"> <li>4. The Contractor must arrange the cancellation of all temporary services.</li> <li>5. Temporary roads must be closed and access across these, blocked.</li> <li>6. All areas where temporary services were installed are to be rehabilitated to the satisfaction of the ECO.</li> </ol> <p><b>Associated infrastructure</b></p> <ol style="list-style-type: none"> <li>7. Surfaces are to be checked for waste products from activities such as concreting or asphaltting and cleared in a manner approved by the Engineer.</li> </ol>	

<b>IMPACT</b>	<b>CONSTRUCTION SITE DECOMMISSIONING</b> This section deals with the demolishing of the construction camp and the actions that need to be implemented	<b>RESPONSIBILITY</b>
<b>PHASE</b>	<b>OPERATION</b>	<b>MC, ECO, EO, ESKOM</b>
<b>ENVIRONMENTAL MANAGEMENT PROGRAMME</b>		
	<p>8. All surfaces hardened due to construction activities are to be ripped and imported material thereon removed.</p> <p>9. All rubble is to be removed from the site to an approved disposal site as approved by the ECO. Burying of rubble on site is prohibited.</p> <p>10. The site is to be cleared of all litter.</p> <p>11. The Contractor is to check that all watercourses are free from building rubble, spoil materials and waste materials.</p> <p>12. Fences, barriers and demarcations associated with the construction phase are to be removed from the site unless stipulated otherwise by the Engineer.</p> <p>13. All residual stockpiles must be removed to spoil or spread on site as directed by the Engineer.</p> <p>14. All leftover building materials must be returned to the depot or removed from the site.</p> <p>15. The Contractor must repair any damage that the construction works has caused to neighbouring properties, specifically, but not limited to, damage caused by poor storm water management.</p> <p><b>Rehabilitation plan</b></p> <p>16. Rehabilitate and re-vegetate cleared areas with indigenous plant species that were present on the site prior to construction.</p> <p>17. All roads utilised during the construction phase must be rehabilitated to an acceptable standard after construction is complete.</p>	

3.5.2 Rehabilitation and Maintenance

**Table 30:** Rehabilitation and Maintenance

IMPACT	REHABILITATION This section deals with the issues relating to rehabilitation after construction	RESPONSIBILITY
PHASE	OPERATION	ESKOM
<b>ENVIRONMENTAL MANAGEMENT PROGRAMME</b>		
<b>MITIGATION / METHOD STATEMENT</b>	<p><b>Rehabilitation</b></p> <ol style="list-style-type: none"> <li>1. All damaged areas must be rehabilitated upon completion of the contract</li> <li>2. A mixture of vegetation seed can be used provided the mixture is carefully selected to ensure the following: <ul style="list-style-type: none"> <li>▪ Annual and perennial species are chosen.</li> <li>▪ Pioneer species are included.</li> <li>▪ All the species must not be edible.</li> <li>▪ Species chosen will grow in the area under natural conditions.</li> <li>▪ Root systems must have a binding effect on the soil.</li> <li>▪ The final product must not cause an ecological imbalance in the area.</li> </ul> </li> <li>3. To get the best results in a specific area, it is advisable to consult with a vegetation specialist. Seed distributors can also give valuable advice as to the mixtures and amount of seed necessary to seed a certain area.</li> <li>4. All natural areas impacted during construction must be rehabilitated with locally indigenous grasses that were present on the site prior to construction.</li> <li>5. Rehabilitation must take place in a phased approach as soon as possible.</li> <li>6. Rehabilitation process must make use of species indigenous to the area that were present on the site prior to construction. Seeds from surrounding seed banks can be used for re-seeding.</li> <li>7. Rehabilitation must be executed in such a manner that surface run-off will not cause erosion of disturbed areas.</li> </ol>	

<b>IMPACT</b>	<b>REHABILITATION</b> This section deals with the issues relating to rehabilitation after construction	<b>RESPONSIBILITY</b>
<b>PHASE</b>	<b>OPERATION</b>	<b>ESKOM</b>
<b>ENVIRONMENTAL MANAGEMENT PROGRAMME</b>		
	8. Planting of indigenous tree species in areas not to be cultivated or built on must be encouraged.  <b>Maintenance</b> 9. The servitude needs to be monitored every three (3) months for the first year to identify the emergence of alien species and any erosion concerns.	

### 3.5.3 Operation and Maintenance

**Table 31:** Operation and Maintenance

<b>IMPACT</b>	<b>OPERATION AND MAINTENANCE</b> This section deals with the potential impacts that could result from the operation and maintenance of the line and substation.	<b>RESPONSIBILITY</b>
<b>PHASE</b>	<b>OPERATION</b>	<b>ESKOM</b>
<b>ENVIRONMENTAL MANAGEMENT PROGRAMME</b>		
<b>MITIGATION / METHOD STATEMENT</b>	<b>Maintenance</b> 1. All applicable standards, legislation, policies and procedures must be adhered to during operation. 2. Regular ground inspection of the servitude and substations must take place to monitor their status. 3. Landowner conditions for accessing the servitude must be adhered to, and all gates must be kept open / closed subject to landowner requirements. 4. Only authorised Eskom personnel must access the servitude and properties that are required to be traversed in order to access the servitude	



	<b>Public awareness</b> 5. The emergency preparedness plan must be ready for implementation at all times should an emergency situation arise.	
<b>SPECIFIC MITIGATION MEASURES</b>		
	6. Strict rules of conduct and access control procedures must be enforced at all times to ensure that the personal property of the land owners on and surrounding the site is respected by all workers/contractors of the project proponent. 7. The conditions set and requested by the directly affected land owner must be adhered to in order to limit the interruption to agricultural production. 8. Ensure clear communication of the project information and effective public participation processes to minimise the influx of migrant job seekers. 9. Manage workers to ensure that they are only on site during the reasonable working hours.	

#### 3.5.4 Avifauna

**Table 32:** Avifauna

<b>IMPACT</b>	<b>AVIFAUNA</b> This section deals with avifaunal issues and actions that need to be implemented during operation	<b>RESPONSIBILITY</b>
<b>PHASE</b>	<b>OPERATION</b>	<b>ESKOM</b>
<b>ENVIRONMENTAL MANAGEMENT PROGRAMME</b>		
<b>MITIGATION / METHOD STATEMENT</b>	1. The proposed power line must be marked with Bird Flight Diverters, to reduce the risk of collisions.	
<b>SPECIFIC MITIGATION MEASURES</b>		
	2. A 300m exclusion zone must be implemented around the existing water points and pans where no construction activity or disturbance should take place.	

<b>IMPACT</b>	<b>AVIFAUNA</b> This section deals with avifaunal issues and actions that need to be implemented during operation	<b>RESPONSIBILITY</b>
<b>PHASE</b>	<b>OPERATION</b>	<b>ESKOM</b>
<b>ENVIRONMENTAL MANAGEMENT PROGRAMME</b>		
	<p>3. A 1.2km exclusion zone must be implemented around the active Martial Eagle nest on the Aries – Helios 400kV line at -30.517644 19.550840 in the power line study area where no construction activity or disturbance should take place.</p> <p>4. The power line must be marked with Bird Flight Diverters (BFD) for its entire length on the earth wire of the line, 5m apart, alternating black and white. See APPENDIX D of the Avifaunal Specialist's report for the type of Bird Flight Diverter which is recommended.</p>	

### 3.5.5 Air Quality

**Table 33:** Air quality

<b>IMPACT</b>	<b>AIR POLLUTION</b> This section deals with the issues relating to air pollution during operation	<b>RESPONSIBILITY</b>
<b>PHASE</b>	<b>OPERATION</b>	<b>ESKOM</b>
<b>ENVIRONMENTAL MANAGEMENT PROGRAMME</b>		
<b>MITIGATION / METHOD STATEMENT</b>	<p><b>Dust management</b></p> <p>1. Any dirt roads utilised to access the sites must be regularly maintained and dust mitigation measures to be enforced to ensure that dust levels are controlled.</p> <p><b>Litter management</b></p> <p>2. Remove unwanted materials and litter on a regular basis to avoid potential odours.</p>	

3.5.6 Biodiversity

**Table 34:** Biodiversity

IMPACT	BIODIVERSITY (FAUNA AND FLORA) This section details with the issues relating to biodiversity during operation	RESPONSIBILITY
PHASE	OPERATION	ESKOM
ENVIRONMENTAL MANAGEMENT PROGRAMME		
MITIGATION / METHOD STATEMENT	<p><b>Flora</b></p> <ol style="list-style-type: none"> <li>1. Indigenous vegetation must be maintained and all exotics removed as they appear and disposed of appropriately.</li> <li>2. Re-vegetation of the disturbed site is aimed at approximating as near as possible the natural vegetative conditions prevailing prior to construction.</li> <li>3. Vegetative re-establishment must, as far as possible, make use of indigenous or locally occurring plant varieties within the servitude.</li> <li>4. Wherever excavation is necessary, topsoil must be set aside and replaced after construction to encourage natural regeneration of the local indigenous species.</li> <li>5. Rehabilitation must be executed in such a manner that surface run-off will not cause erosion of disturbed areas during and following rehabilitation.</li> <li>6. Due to the disturbance at the site as well as the increased runoff generated by the hard infrastructure, alien plant species are likely to be a long-term problem at the site and a long-term control plan will need to be implemented. Problem woody species such as <i>Prosopis</i> are already present in the area and are likely to increase rapidly if not controlled.</li> <li>7. Regular monitoring for alien plants within the development footprint as well as adjacent areas which receive runoff from the new development as there are also likely to be prone to invasion problems.</li> <li>8. Regular alien clearing must be conducted using the best-practice methods for the species concerned. The use of herbicides must be avoided as far as possible.</li> </ol>	

IMPACT	<b>BIODIVERSITY (FAUNA AND FLORA)</b> This section details with the issues relating to biodiversity during operation	RESPONSIBILITY
<b>PHASE</b>	<b>OPERATION</b>	<b>ESKOM</b>
<b>ENVIRONMENTAL MANAGEMENT PROGRAMME</b>		
	<p><b>Fauna</b></p> <p>9. No faunal species must be harmed by maintenance staff during any routine maintenance on the servitude or at the substations.</p> <p>10. Management of the servitude and the substation sites must take place within the context of an Open Space Management Plan.</p> <p>11. Any potentially dangerous fauna such snakes or fauna threatened by the maintenance and operational activities must be removed to a safe location.</p> <p>12. The collection, hunting or harvesting of any plants or animals at the site must be strictly forbidden by anyone except landowners or other individuals with the appropriate permits and permissions where required.</p> <p>13. If any parts of the site need to be lit at night for security purposes, this must be done with downward-directed low-UV type lights (such as most LEDs) as far as possible, which do not attract insects.</p> <p>14. All hazardous materials must be stored in the appropriate manner to prevent contamination of the site. Any accidental chemical, fuel and oil spills that occur at the site must be cleaned up in the appropriate manner as related to the nature of the spill.</p> <p>15. All vehicles accessing the substation sites and servitude must adhere to a low speed limit (40km/h max) to avoid collisions with susceptible species such as snakes and tortoises.</p> <p>16. If parts of the facility such as the substation are to be fenced, no electrified strands must be placed within 30cm of the ground as some species such as tortoises are susceptible to electrocution as they do not move away when electrocuted but rather adopt defensive behavior and are killed by repeated shocks. Alternatively, the electrified strands must be placed on the inside of the fence and not the outside.</p>	

IMPACT	<b>BIODIVERSITY (FAUNA AND FLORA)</b> This section details with the issues relating to biodiversity during operation	RESPONSIBILITY
PHASE	OPERATION	ESKOM
<b>ENVIRONMENTAL MANAGEMENT PROGRAMME</b>		
	<p>17. Erosion management at the site must take place according to the Erosion Management Plan and Rehabilitation Plan.</p> <p>18. All roads and other hardened surfaces must have runoff control features which redirect water flow and dissipate any energy in the water which may pose an erosion risk.</p> <p>19. Regular monitoring for erosion after construction to ensure that no erosion problems have developed as result of the disturbance, as per the Erosion Management and Rehabilitation Plans for the project.</p> <p>20. All erosion problems observed must be rectified as soon as possible, using the appropriate erosion control structures and re-vegetation techniques. Any roads that will not be rehabilitated must have runoff control features which redirect water flow and dissipate any energy in the water which may pose an erosion risk.</p> <p>21. All cleared areas must be re-vegetated with indigenous perennial shrubs and grasses from the local area. These can be cut when dry and placed on the cleared areas if natural recovery is slow.</p> <p>22. There must be an integrated management plan for the development area during operation, which is beneficial to fauna and flora.</p>	
<b>SPECIFIC MITIGATION MEASURES</b>		
	<p>23. Erosion management at the site must take place according to the Erosion Management Plan and Rehabilitation Plan.</p> <p>24. All hardened surfaces must have runoff control features which redirect water flow and dissipate any energy in the water which may pose an erosion risk.</p> <p>25. Regular monitoring for erosion after construction to ensure that no erosion problems have developed as result of the disturbance, as per the Erosion Management and Rehabilitation Plans for the project.</p> <p>26. All erosion problems observed must be rectified as soon as possible, using the appropriate erosion control structures and re-vegetation techniques.</p>	

<b>IMPACT</b>	<b>BIODIVERSITY (FAUNA AND FLORA)</b> This section details with the issues relating to biodiversity during operation	<b>RESPONSIBILITY</b>
<b>PHASE</b>	<b>OPERATION</b>	<b>ESKOM</b>
<b>ENVIRONMENTAL MANAGEMENT PROGRAMME</b>		
	<p>27. All cleared areas must be re-vegetated with indigenous perennial shrubs and grasses from the local area. These can be cut when dry and placed on the cleared areas if natural recovery is slow.</p> <p>28. Wherever excavation is necessary, topsoil must be set aside and replaced after construction to encourage natural regeneration of the local indigenous species.</p> <p>29. Regular monitoring for alien plants within the development footprint must be carried out.</p> <p>30. Regular alien clearing must be conducted using the best-practice methods for the species concerned. The use of herbicides must be avoided as far as possible.</p>	

### 3.5.7 Agriculture

**Table 35:** Agriculture

<b>IMPACT</b>	<b>AGRICULTURE</b> This section deals with issues relating to agricultural potential and resources and actions that need to be implemented during operation	<b>RESPONSIBILITY</b>
<b>PHASE</b>	<b>OPERATION</b>	<b>ESKOM</b>
<b>MITIGATION / METHOD STATEMENT</b>	<p><b>Erosion</b></p> <p>1. Implement an effective system of run-off control, where it is required, that collects and safely disseminates run-off water from all hardened surfaces and prevents potential down slope erosion. Any occurrences of erosion must be attended to immediately and the integrity of the erosion control system at that point must be amended to prevent further erosion from occurring there.</p> <p>2. Maintain where possible all vegetation cover and facilitate re-vegetation of denuded areas throughout the site, to stabilize the soil against erosion.</p>	

### 3.5.8 Surface Water Resources

**Table 36:** Surface Water Resources

<b>IMPACT</b>	<b>SURFACE WATER</b> This section deals with the issues relating to surface water during operation	<b>RESPONSIBILITY</b>
<b>PHASE</b>	<b>OPERATION</b>	<b>ESKOM</b>
<b>ENVIRONMENTAL MANAGEMENT PROGRAMME</b>		
<b>MITIGATION / METHOD STATEMENT</b>	<ol style="list-style-type: none"> <li>1. All surface water resources and buffer zones must be avoided as far as practically possible in the final layouts (including access / service roads and power lines, including tower positions) to be designed in order to minimise and potentially avoid potential impacts as far as possible.</li> <li>2. Where it is not possible to avoid impacts to surface water resources as a result of roads and power lines, the necessary water use license / general authorisation and environmental authorisations as relevant will be required prior to construction.</li> <li>3. All stipulated mitigation measures are to be adhered to in order to minimise potential impacts to surface water resources.</li> </ol>	
<b>SPECIFIC MITIGATION MEASURES</b>		
	<p><b>Minimising Vehicle Damage to the Surface Water Resources</b></p> <ol style="list-style-type: none"> <li>4. Potential impacts can be avoided by planning and routing of access / service roads outside of and away from all surface water resources and the associated buffer zones.</li> <li>5. Where access through surface water resources is unavoidable and is absolutely required, it is recommended that any road plan and associated structures (such as ford crossings, stormwater flow pipes, culverts, culvert bridges etc.) be submitted to the relevant environmental and water departments for approval prior to construction.</li> <li>6. Internal access and service roads authorised in sensitive areas will have to be regularly monitored and checked for erosion. Monitoring must be conducted once every month. Moreover, after short or</li> </ol>	

	<p>long periods of heavy rainfall or after long periods of sustained rainfall the roads will need to be checked for erosion. Rehabilitation measures will need to be employed should erosion be identified.</p> <p><b>Erosion control</b></p> <p>7. Where erosion begins to take place, this must be dealt with immediately to prevent significant erosion damage to the surface water resources. Should large scale erosion occur, a rehabilitation plan will be required. Input, reporting and recommendations from a suitably qualified wetland / aquatic specialist must be obtained in this respect should this be required.</p> <p>8. Control of erosion on the substation sites and along the servitude must be managed through implementation of an erosion management plan. Erosion and subsequent sedimentation of surface water resources are considered significant impacts in terms of the proposed development that must be managed adequately throughout the operation of the proposed development.</p> <p>9. Rehabilitation of the internal road crossing areas will be required post-construction. Ideally, the affected areas must be levelled, or appropriately sloped and scarified to loosen the soil and allow seeds contained in the natural seed bank to re-establish. However, given the aridity of the study area, it is likely that vegetation recovery will be slow. Rehabilitation areas will need to be monitored for erosion until vegetation can re-establish where prevalent. If affected areas are dry and no vegetation is present, the soil is to be re-instated and sloped.</p>	
--	--	--

3.5.9 Health and Safety

**Table 37:** Health and Safety

<b>IMPACT</b>	<b>HEALTH AND SAFETY</b> This section deals with the issues relating to health and safety during operation	<b>RESPONSIBILITY</b>
<b>PHASE</b>	<b>OPERATION</b>	<b>ESKOM</b>
<b>ENVIRONMENTAL MANAGEMENT PROGRAMME</b>		



<b>IMPACT</b>	<b>HEALTH AND SAFETY</b> This section deals with the issues relating to health and safety during operation	<b>RESPONSIBILITY</b>
<b>MITIGATION / METHOD STATEMENT</b>	<p><b>Emergency evacuation plan</b></p> <p>1. Upon completion of the construction phase, an emergency evacuation plan must be drawn up to ensure the safety of the staff and surrounding land users in the case of an emergency.</p> <p><b>Maintenance</b></p> <p>2. The servitude is to be regularly maintained. A maintenance schedule must be drawn up and records of all maintenance kept.</p> <p><b>Storage and handling of hazardous waste</b></p> <p>3. A spill kit needs to be kept on site to address any unforeseen spillages.</p> <p>4. Transport of all hazardous substances must be in accordance with the relevant legislation.</p>	

### 3.5.10 Social Environment

**Table 38:** Social Environment

<b>IMPACT</b>	<b>SOCIAL ENVIRONMENT</b> This section deals with social environment and actions that need to be implemented during operation	<b>RESPONSIBILITY</b>
<b>PHASE</b>	<b>OPERATION</b>	<b>ESKOM</b>
<b>ENVIRONMENTAL MANAGEMENT PROGRAMME</b>		
<b>MITIGATION / METHOD STATEMENT</b>	<p>1. All contact with the affected parties must be courteous at all times. The rights of the affected parties must be respected at all times.</p> <p>2. Ensure that the expectations (rules) of the farmers regarding access to farms are understood and effectively adhered to.</p>	
<b>SPECIFIC MITIGATION MEASURES</b>		

<b>IMPACT</b>	<b>SOCIAL ENVIRONMENT</b> This section deals with social environment and actions that need to be implemented during operation	<b>RESPONSIBILITY</b>
<b>PHASE</b>	<b>OPERATION</b>	<b>ESKOM</b>
<b>ENVIRONMENTAL MANAGEMENT PROGRAMME</b>		
	<ol style="list-style-type: none"> <li>3. Care must be taken not to damage existing farm fences</li> <li>4. Access to the power line servitude and substations must be strictly controlled and rules made by the farmers regarding access to their properties must also be adhered to.</li> <li>5. Where feasible, the proponent is to ensure the employment of local labour for maintenance work during the operational phase.</li> <li>6. Movement of maintenance workers on and off the substation sites and power line servitude must be closely monitored and managed.</li> <li>7. Where possible, assist the local municipality in ensuring that the quality of the social and economic infrastructure does not deteriorate by making use of social responsibility allocations.</li> <li>8. Implement mitigation measures recommended by the other relevant specialists (i.e. visual and noise).</li> </ol>	

3.5.11 Heritage

**Table 39:** Heritage

<b>IMPACT</b>	<b>CULTURAL AND HERITAGE ARTEFACTS</b> This section deals with the impact that the new development has on potential archaeological artefacts on the site	<b>RESPONSIBILITY</b>
<b>PHASE</b>	<b>OPERATION</b>	<b>ESKOM</b>
<b>ENVIRONMENTAL MANAGEMENT PROGRAMME</b>		
<b>MITIGATION / METHOD STATEMENT</b>	1. A management plan for the heritage resources needs to be implemented during construction and operations.	

3.5.12 Visual Impact

**Table 40:** Visual Impact

<b>IMPACT</b>	<b>VISUAL IMPACT</b> This section deals with the issues relating to visual impacts during operation	<b>RESPONSIBILITY</b>
<b>PHASE</b>	<b>OPERATION</b>	<b>ESKOM</b>
<b>ENVIRONMENTAL MANAGEMENT PROGRAMME</b>		
<b>MITIGATION / METHOD STATEMENT</b>	<b>Maintenance and lighting</b> 1. High standards of maintenance and management of the landscaping must be carried out in accordance with the best possible practice to ensure that the landscaping ensures that the power line blends in with the current visual environment, by enhancing natural features such as trees and existing vegetation as much as possible. 2. The servitude and surrounds must be kept clean, tidy and well maintained to reduce negative visual	

IMPACT	VISUAL IMPACT This section deals with the issues relating to visual impacts during operation	RESPONSIBILITY
	impacts. 3. Rehabilitation of surrounding areas must take place with indigenous species that were present on the site prior to construction. 4. Regular maintenance of the associated infrastructure must be undertaken.	
<b>SPECIFIC MITIGATION MEASURES</b>		
	5. Light fittings for security at night must reflect the light toward the ground and prevent light spill. 6. As far as possible, limit the amount of security and operational lighting present at the on-site substation. 7. Where possible, limit the number of maintenance vehicles using access roads. 8. Ensure that dust suppression techniques are implemented on gravel access roads utilised during operation, where possible. 9. Non-reflective surfaces must be utilised where possible.	

### 3.6 Decommissioning phase

Mitigation measures implemented during construction with regards to the construction camp and equipment will remain the same for the decommissioning phase when a construction camp will need to be established again.

#### 3.6.1 Ongoing Stakeholder involvement

This is the process that is recommended if the substations sites are decommissioned.

**Table 41:** Ongoing Stakeholder involvement

IMPACT	ONGOING STAKEHOLDER INVOLVEMENT This section relates to the stakeholder involvement that needs occur during decommissioning	RESPONSIBILITY
PHASE	DECOMMISSIONING	ESKOM, CLO
ENVIRONMENTAL MANAGEMENT PROGRAMME		
MITIGATION / METHOD STATEMENT	<ol style="list-style-type: none"> <li>1. Community to be notified, as culturally appropriate, timeously of the planned decommissioning, e.g.:               <ul style="list-style-type: none"> <li>• Proposed decommissioning start date; and</li> <li>• Process to be followed.</li> </ul> </li> <li>2. Recommend that a meeting with community leader(s) be held before decommissioning commence to inform them:               <ul style="list-style-type: none"> <li>• What activities will take place during the decommissioning phase.</li> <li>• How these activities will impact upon the communities and/or their properties.</li> <li>• Regarding the timeframes of scheduled activities</li> </ul> </li> <li>3. Regular interaction between Eskom and community leader(s) during the decommissioning phase</li> <li>4. A reporting office / channel to be established must community members experience problems with contractors / sub-contractors during the decommissioning phase.</li> <li>5. A register to be kept of problems reported by community members and the steps taken to address / resolve it.</li> </ol>	

### 3.6.2 Community health and safety

**Table 42:** Community health and safety

<b>IMPACT</b>	<b>COMMUNITY HEALTH AND SAFETY</b> This section deals with the issues relating to health and safety during decommissioning	<b>RESPONSIBILITY</b>
<b>PHASE</b>	<b>DECOMMISSIONING</b>	<b>ESKOM, CLO</b>
<b>ENVIRONMENTAL MANAGEMENT PROGRAMME</b>		
<b>MITIGATION / METHOD STATEMENT</b>	<ol style="list-style-type: none"> <li>1. Demarcated routes to be established for construction vehicles to ensure the safety of communities, especially in terms of road safety and communities to be informed of these demarcated routes.</li> <li>2. Excavated areas to be fenced off and regularly inspected to ensure that humans and animals do not have access to the site.</li> <li>3. Where dust is generated by trucks passing on gravel roads, dust mitigation measures to be enforced.</li> <li>4. Any infrastructure that would not be decommissioned must be appropriately locked and/or fenced off to ensure that it does not pose any danger to the community.</li> </ol>	

### 3.6.3 Waste Management

**Table 43:** Waste Management

<b>IMPACT</b>	<b>WASTE MANAGEMENT</b> This section deals with the issues relating to waste management during decommissioning	<b>RESPONSIBILITY</b>
<b>PHASE</b>	<b>DECOMMISSIONING</b>	<b>ESKOM, EO</b>
<b>ENVIRONMENTAL MANAGEMENT PROGRAMME</b>		
<b>MITIGATION / METHOD STATEMENT</b>	<ol style="list-style-type: none"> <li>1. All decommissioned equipment must be removed from site and disposed of at a registered land fill. Records of disposal must be kept.</li> </ol>	

### 3.6.4 Agriculture

**Table 44:** Agriculture

<b>IMPACT</b>	<b>AGRICULTURE</b> This section deals with issues relating to agricultural potential and resources and actions that need to be implemented during decommissioning	<b>RESPONSIBILITY</b>
<b>PHASE</b>	<b>DECOMMISSIONING</b>	<b>ESKOM</b>
<b>MITIGATION / METHOD STATEMENT</b>	<p><b>Erosion</b></p> <ol style="list-style-type: none"> <li>1. Implement an effective system of run-off control, where it is required, that collects and safely disseminates run-off water from all hardened surfaces and prevents potential down slope erosion. Any occurrences of erosion must be attended to immediately and the integrity of the erosion control system at that point must be amended to prevent further erosion from occurring there.</li> <li>2. Maintain where possible all vegetation cover and facilitate re-vegetation of denuded areas throughout the site, to stabilize the soil against erosion.</li> </ol>	

### 3.6.5 Surface and Groundwater

**Table 45:** Surface and Groundwater

<b>IMPACT</b>	<b>SURFACE AND GROUNDWATER</b> This section deals with the issues relating to surface and groundwater during decommissioning	<b>RESPONSIBILITY</b>
<b>PHASE</b>	<b>DECOMMISSIONING</b>	<b>ESKOM, EO</b>
<b>ENVIRONMENTAL MANAGEMENT PROGRAMME</b>		
<b>MITIGATION / METHOD STATEMENT</b>	<ol style="list-style-type: none"> <li>1. Removal of any historically contaminated soil as hazardous waste must be undertaken.</li> <li>2. Removal of hydrocarbons and other hazardous substances by a suitable contractor to reduce contamination risks must be undertaken.</li> <li>3. Removal of all substances which can result in groundwater (or surface water) contamination must be undertaken.</li> </ol>	

	4. Re-vegetation of exposed soil surfaces to ensure no erosion in these areas is to be undertaken.	
--	--	--

### 3.6.6 Biodiversity

**Table 46:** Biodiversity

<b>IMPACT</b>	<b>BIODIVERSITY</b> This section deals with the issues relating to biodiversity during decommissioning	<b>RESPONSIBILITY</b>
<b>PHASE</b>	<b>DECOMMISSIONING</b>	<b>ESKOM, EO</b>
<b>ENVIRONMENTAL MANAGEMENT PROGRAMME</b>		
<b>MITIGATION / METHOD STATEMENT</b>	<p><b>Fauna</b></p> <ol style="list-style-type: none"> <li>Any potentially dangerous fauna such as snakes or fauna threatened by the decommissioning activities must be removed to a safe location prior to the commencement of decommissioning activities.</li> <li>All hazardous materials must be stored in the appropriate manner to prevent contamination of the site. Any accidental chemical, fuel and oil spills that occur at the site must be cleaned up in the appropriate manner as related to the nature of the spill.</li> <li>All vehicles accessing the site must adhere to a low speed limit (40km/h max) to avoid collisions with susceptible species such as snakes and tortoises.</li> <li>No excavated holes or trenches must be left open for extended periods as fauna must fall in and become trapped.</li> <li>All above-ground infrastructure must be removed from the site. Below-ground infrastructure such as cabling can be left in place if it does not pose a risk, as removal of such cables must generate additional disturbance and impact, however, this must be in accordance with the decommissioning and recycling plan, and as per the agreements with the land owners concerned.</li> </ol> <p><b>Erosion control</b></p>	



	<p>6. There must be regular monitoring for erosion for at least 2 years after decommissioning by the applicant to ensure that no erosion problems develop as a result of the disturbance, and if they do, to immediately implement erosion control measures.</p> <p>7. All erosion problems observed must be rectified as soon as possible, using the appropriate erosion control structures and re-vegetation techniques.</p> <p>8. All disturbed and cleared areas must be re-vegetated with indigenous perennial shrubs and grasses from the local area.</p> <p><b>Alien invasive plant control</b></p> <p>9. Wherever excavation is necessary for decommissioning, topsoil must be set aside and replaced after construction to encourage natural regeneration of the local indigenous species.</p> <p>10. Due to the disturbance at the site alien plant species are likely to be a long-term problem at the site following decommissioning and regular control will need to be implemented until a cover of indigenous species has returned.</p> <p>11. Regular monitoring for alien plants within the disturbed areas for at least two years after decommissioning or until alien invasives are no longer a problem at the site.</p> <p>12. Regular alien clearing must be conducted using the best-practice methods for the species concerned. The use of herbicides must be avoided as far as possible.</p>	
--	--	--

### 3.6.7 Air Quality

**Table 47:** Air Pollution

IMPACT	AIR POLLUTION	RESPONSIBILITY
	<b>This section deals with the issues relating to air quality during decommissioning</b>	
PHASE	DECOMMISSIONING	ESKOM, EO
<b>ENVIRONMENTAL MANAGEMENT PROGRAMME</b>		

<b>MITIGATION / METHOD STATEMENT</b>	1. Regular maintenance of equipment to ensure reduced exhaust emissions	
--------------------------------------	---	--

### 3.6.8 Visual Impact

**Table 48:** Visual Impact

<b>IMPACT</b>	<b>VISUAL</b>	<b>RESPONSIBILITY</b>
	This section deals with visual issues and actions that need to be implemented during decommissioning	
<b>PHASE</b>	<b>DECOMMISSIONING</b>	<b>MC, EO, ECO</b>
<b>ENVIRONMENTAL MANAGEMENT PROGRAMME</b>		
<b>MITIGATION / METHOD STATEMENT</b>	<p><b>General</b></p> <ol style="list-style-type: none"> <li>1. Decommissioning activities must not occur at night and lighting must only be erected where absolutely necessary.</li> <li>2. Decommissioning traffic must stick to designated routes or access roads.</li> <li>3. Decommissioning areas are to be kept clean and tidy.</li> <li>4. Measures must be taken to suppress dust arising from decommissioning activities.</li> <li>5. Labour being transported to the site must take cognisance of litter and waste concerns.</li> <li>6. Equipment being transported to and from the site must be covered with tarps.</li> <li>7. Topsoil stockpiles must be well managed and seeded when possible if not utilised within three months.</li> <li>8. It is recommended that equipment be stored discreetly so as not to increase visual impacts.</li> <li>9. Decommissioning must be conducted in the shortest possible time in order to reduce visual impacts.</li> </ol>	
<b>SPECIFIC MITIGATION MEASURES</b>		
	<ol style="list-style-type: none"> <li>10. Carefully plan to avoid any delays or extensions to the decommissioning period.</li> <li>11. Minimise vegetation clearing and rehabilitate cleared areas as soon as possible.</li> <li>12. Vegetation clearing must take place in a phased manner.</li> </ol>	

	<ol style="list-style-type: none"><li>13. Maintain a neat site by removing rubble and waste materials regularly.</li><li>14. Make use of existing gravel access roads where possible.</li><li>15. Limit the number of vehicles and trucks travelling to and from the proposed site, where possible.</li><li>16. If dust plumes become an issue, dust suppression techniques must be implemented on gravel access roads utilised during decommissioning, where possible.</li><li>17. Ensure that all soil stockpiles are covered in order to reduce dust.</li><li>18. Establish erosion control measures on areas which will be exposed for long periods of time. This is to reduce the potential impact heavy rains must have on the bare soil.</li></ol>	
--	---	--

## 4 ADDITIONAL MANAGEMENT PLANS

### 4.1 Alien Invasive Management Plan

**Table 49:** Alien Invasive Management Plan

<b>ALIEN INVASIVE MANAGEMENT PROGRAMME</b>	
<b>MITIGATION MEASURES</b>	<ol style="list-style-type: none"> <li>1. Stockpiles must be kept clear of weeds and alien vegetation growth by regular weeding.</li> <li>2. Alien vegetation and the spread of exotic species on the site will need to be controlled.</li> <li>3. The contractor must be responsible for implementing a programme of weed control (particularly in areas where soil has been disturbed); and grassing of any remaining stockpiles to prevent weed invasion.</li> <li>4. Herbicide use must only be allowed according to contract specifications. The application must be according to set specifications and under supervision of a qualified technician. The possibility of leaching into the surrounding environment must be properly investigated and only environmentally friendly herbicides must be used.</li> <li>5. The use of pesticides and herbicides along the power line servitude must be discouraged as these can impact on important pollinator species of indigenous vegetation.</li> <li>6. Six monthly checks of the area must take place for the emergence of invader species.</li> <li>7. Mitigation measures mentioned for the construction phase above must be implemented for any maintenance of the development that must be undertaken during the operation phase.</li> <li>8. Correct rehabilitation with locally indigenous species.</li> <li>9. Monitoring programme to ensure that rehabilitation efforts are successful to ensure that risks such as erosion, spread of exotic species and the edge effect are avoided.</li> <li>10. Constant maintenance of the area to ensure re-colonisation of floral species.</li> <li>11. Regular removal of alien species which may jeopardise the proliferation of indigenous species.</li> </ol>

## 4.2 Plant Rescue and Protection Plan

**Table 50:** Plant Rescue and Protection Plan

<b>PLANT RESCUE PROTECTION PLAN</b>	
<b>MITIGATION MEASURES</b>	<ol style="list-style-type: none"> <li>1. Preconstruction walk-through of the approved development footprint to ensure that sensitive habitats and species are avoided where possible.</li> <li>2. The removal of protected plant species from the proposed development areas must take place prior to construction commencing. These plant species should be grown ex-situ and then relocated after construction has been completed.</li> <li>3. Where possible, preference be given to conservation organisations to remove seeds, cuttings and plants prior to construction commencing for conservation purposes.</li> <li>4. A large proportion of the impact of the development stems from the access roads and the number of roads must be reduced to the minimum possible and routes must also be adjusted to avoid areas of high sensitivity as far as possible, as informed by a preconstruction walk-through survey.</li> <li>5. Preconstruction walk-through of the facility to identify areas of faunal sensitivity.</li> <li>6. Preconstruction environmental induction for all construction staff on site to ensure that basic environmental principles are adhered to. This includes topics such as no littering, appropriate handling of pollution and chemical spills, avoiding fire hazards, minimizing wildlife interactions, remaining within demarcated construction areas etc.</li> <li>7. A pre-construction walk-through survey by the biodiversity specialist will be required during a favourable season to locate any protected plants / trees and/or sensitive species and/or ecological feature. This survey must cover the footprint of all proposed infrastructure, including internal access roads. If necessary, shift infrastructure to avoid impacts on species or specific features.</li> <li>8. Vegetation clearing must only commence after the walk-through has been conducted and necessary permits obtained. The Northern Cape Nature Conservation Act permit conditions must also be complied with.</li> <li>9. Vegetation clearing to be kept to a minimum. No unnecessary vegetation to be cleared.</li> <li>10. Vegetation removal must be limited to the wind farm construction site.</li> <li>11. Vegetation to be removed as it becomes necessary rather than removal of all vegetation throughout the site in one step.</li> </ol>

	<p>12. Materials must not be delivered to the site prematurely which could result in additional areas being cleared or affected.</p> <p>13. No vegetation to be used for firewood.</p> <p>14. Gathering of firewood, fruit, “muti” plants, or any other natural material onsite or in areas adjacent to the site is prohibited unless with prior approval of the ECO.</p> <p>15. Only vegetation within the study area must be removed.</p> <p>16. Vegetation removal must be phased in order to reduce impact of construction.</p> <p>17. Construction site office and laydown areas must be clearly demarcated and no encroachment must occur beyond demarcated areas.</p> <p>18. All natural areas impacted during construction must be rehabilitated with locally indigenous plant species.</p> <p>19. A buffer zone must be established in areas where construction will not take place to ensure that construction activities do not extend into these areas.</p> <p>20. Construction areas must be well demarcated and these areas strictly adhered to.</p> <p>21. The use of pesticides and herbicides in the study area must be discouraged as these impacts on important pollinator species of indigenous vegetation.</p> <p>22. Soils must be kept free of petrochemical solutions that must be kept on site during construction. Spillage can result in a loss of soil functionality thus limiting the re-establishment of flora.</p> <p>23. The grid access power line must span rocky areas in order to avoid transformation in these areas.</p> <p>24. Soil stockpiles must not become contaminated with oil, diesel, petrol, garbage or any other material, which must inhibit the later growth of vegetation in the soil.</p>
--	--

The above Plant Recue and Protection Plan will be updated by a vegetation specialist once the detailed design stages of the proposed development are complete and the floral walk-through study has been undertaken.

### 4.3 Re-Vegetation and Habitat Rehabilitation Plan

**Table 51:** Re-Vegetation and Habitat Rehabilitation Plan

<b>RE-VEGETATION AND HABITAT REHABILITATION PLAN</b>
--

<b>MITIGATION MEASURES</b>	<ol style="list-style-type: none"> <li>1. Re-vegetation must aim to accelerate the natural succession processes so that the plant community develops in the desired way, i.e. promote rapid vegetation establishment.</li> <li>2. Re-vegetation of disturbed surfaces must occur immediately after construction activities are completed. This must be done through seeding with indigenous grasses.</li> <li>3. All damaged areas must be rehabilitated upon completion of the contract.</li> <li>4. Re-vegetation of the disturbed site is aimed at approximating as near as possible the natural vegetative conditions prevailing prior to construction.</li> <li>5. All natural areas impacted during construction must be rehabilitated with locally indigenous species typical of the representative botanical unit.</li> <li>6. Rehabilitation must take place in a phased approach as soon as possible.</li> <li>7. Rehabilitation process must make use of species indigenous to the area. Seeds from surrounding seed banks can be used for re-seeding.</li> <li>8. Rehabilitation must be executed in such a manner that surface run-off will not cause erosion of disturbed areas.</li> <li>9. Planting of indigenous tree species in areas not to be cultivated or built on must be encouraged.</li> <li>10. Habitat destruction must be limited to what is absolutely necessary for the construction of the infrastructure, including the construction of new roads. In this respect, the recommendations from the Ecological Specialist Study must be applied strictly. Personnel must be adequately briefed on the need to restrict habitat destruction, and must be restricted to the actual construction area.</li> <li>11. Monitoring programme to ensure that rehabilitation efforts are successful to ensure that risks such as erosion, spread of exotic species and the edge effect are avoided.</li> </ol>
----------------------------	--

The above Re-Vegetation and Habitat Rehabilitation Plan will be updated by a vegetation specialist once the detailed design stages of the proposed development are complete and the floral walk-through study has been undertaken.

#### 4.4 Erosion Management Plan

**Table 52:** Erosion Management Plan

<b>EROSION MANAGEMENT PLAN</b>
--------------------------------

<b>MITIGATION MEASURES</b>	<ol style="list-style-type: none"> <li>1. To prevent erosion, material stockpiled for long periods (2 weeks) must be retained in a bermed area.</li> <li>2. Areas which are not to be constructed on within two months must not be cleared to reduce erosion risks.</li> <li>3. The area to be cleared must be clearly demarcated and this footprint strictly maintained.</li> <li>4. Wind screening and stormwater control must be undertaken to prevent soil loss from the site.</li> <li>5. Other erosion control measures that can be implemented are as follows: <ol style="list-style-type: none"> <li>a. Brush packing with cleared vegetation</li> <li>b. Mulch or chip packing</li> <li>c. Planting of vegetation</li> <li>d. Hydroseeding / hand sowing</li> </ol> </li> <li>6. Sensitive areas need to be identified prior to construction so that the necessary precautions can be implemented.</li> <li>7. All erosion control mechanisms need to be regularly maintained.</li> <li>8. Seeding of topsoil and subsoil stockpiles to prevent wind and water erosion of soil surfaces.</li> <li>9. Retention of vegetation where possible to avoid soil erosion.</li> <li>10. Vegetation clearance must be phased to ensure that the minimum area of soil is exposed to potential erosion at any one time.</li> <li>11. Re-vegetation of disturbed surfaces must occur immediately after construction activities are completed. This must be done through seeding with indigenous grasses that were present on site prior to construction.</li> <li>12. No impediment to the natural water flow other than approved erosion control works is permitted.</li> <li>13. To prevent stormwater damage, the increase in stormwater run-off resulting from construction activities must be estimated and the drainage system assessed accordingly.</li> <li>14. Stockpiles not used in three (3) months after stripping must be seeded to prevent dust and erosion.</li> </ol>
----------------------------	---

#### 4.5 Storm Water Management Plan

A Storm Water Management Plan cannot be compiled until the detailed design stages of the proposed development are complete, which will only take place if the proposed !Xha Boom Wind Farm and the proposed !Xha Boom Substation, Linking Substation and power line developments are authorised by the DEA. It is however stipulated in this EMP that a Storm Water Management Plan must be compiled before any construction commences and be implemented during the construction phase. Refer to **Section 3.4.8**



## 4.6 Open Space Management Plan

**Table 53:** Open Space Management Plan

<b>OPEN SPACE MANAGEMENT PLAN</b>	
<b>MITIGATION MEASURES</b>	<ol style="list-style-type: none"> <li>1. A buffer zone must be established in areas where construction will not take place, to ensure that construction activities do not extend into these areas.</li> <li>2. Vehicle movement must be restricted to authorised access roads.</li> <li>3. Before construction begins, all areas to be developed must be clearly demarcated with fencing or orange construction barrier where applicable.</li> <li>4. All Construction Camps are to be fenced off in such a manner that unlawful entry is prevented and access is controlled. Signage must be erected at all access points in compliance with all applicable occupational health and safety requirements. All access points to the Construction Camp must be controlled by a guard or otherwise monitored, to prevent unlawful access.</li> <li>5. The contractor and ECO must ensure compliance with conditions described in the EA.</li> <li>6. Records of compliance/ non-compliance with the conditions of the authorisation must be kept and be available on request.</li> <li>7. Records of all environmental incidents must be maintained and a copy of these records be made available to the national and provincial departments on request throughout the project execution.</li> <li>8. Site establishment must take place in an orderly manner and all required amenities must be installed at camp sites before the main workforce move onto site.</li> <li>9. All construction equipment must be stored within this construction camp.</li> <li>10. An area for the storage of hazardous materials must be established that conforms to the relevant safety requirements and that provides for spillage prevention and containment.</li> <li>11. The Contractor must provide sufficient ablution facilities, in the form of portable / VIP toilets, at the Construction Camps, and must conform to all relevant health and safety standards and codes. No pit latrines, French drain systems or soak away systems must be allowed and toilets must not be situated within 100 meters of any surface</li> </ol>

	<p>water body or 1:100 year flood line. A sufficient number of toilets must be provided to accommodate the number of personnel working in the area.</p> <p>12. The Contractor must inform all site staff to make use of supplied ablution facilities and under no circumstances must indiscriminate sanitary activities be allowed.</p> <p>13. No fires will be allowed and the Contractor must make alternative arrangements for heating. LP Gas must be used, provided that all required safety measures are in place. The Contractor must take specific measures to prevent the spread of veld fires, caused by activities at the campsites. These measures must include appropriate instruction of employees about fire.</p> <p>14. Environmental awareness training for construction staff, concerning the prevention of accidental spillage of hazardous chemicals and oil; pollution of water resources (both surface and groundwater), air pollution and litter control and identification of archaeological artefacts.</p> <p>15. Project manager must ensure that the training and capabilities of the Contractor's site staff are adequate to carry out the designated tasks.</p> <p>16. Staff must be educated as to the need to refrain from indiscriminate waste disposal and/or pollution of local soil and water resources and receive the necessary safety training.</p> <p>17. Staff must be trained in the hazards and required precautionary measures for dealing with these substances</p>
--	---

## 4.7 Monitoring System

**Table 54:** Monitoring System

<b>MONITORING SYSTEM</b>	
<b>MITIGATION MEASURES</b>	<ol style="list-style-type: none"> <li>1. Monitoring must be undertaken to evaluate the success of mitigation measures. Monitoring methods must be in accordance with features that need to be monitored.</li> <li>2. An area for the storage of hazardous materials must be established that conforms to the relevant safety requirements and provides for spillage prevention and containment.</li> <li>3. Environmental awareness training for construction staff, concerning the prevention of accidental spillage of hazardous chemicals and oil; pollution of water resources (both surface and groundwater), air pollution and litter control.</li> </ol>

4. Spillage packs must be available at construction areas.
5. Proper storage facilities for the storage of oils, paints, grease, fuels, chemicals and any hazardous materials to be used must be provided to prevent the migration of spillage into the ground and groundwater regime around the temporary storage area(s). These pollution prevention measures for storage must include a bund wall high enough to contain at least 110% of any stored volume, and this must be sited away from drainage lines in a site with the approval of the Project Manager. The bund wall must be high enough to contain 110% of the total volume of the stored hazardous material with an additional allocation for potential storm water events.
6. These storage facilities (including any tanks) must be on an impermeable surface that is protected from the ingress of storm water from surrounding areas in order to ensure that accidental spillage does not pollute local soil or water resources.
7. An approved waste disposal contractor must be employed to remove and recycle waste oil, if practical. The contractor must ensure that its staff is made aware of the health risks associated with any hazardous substances used and has been provided with the appropriate protective clothing/equipment in case of spillages or accidents and have received the necessary training.
8. Where contamination of soil is expected, analysis must be done prior to disposal of soil to determine the appropriate disposal route. Proof from an approved waste disposal site where contaminated soils are dumped if and when a spillage / leakage occur must be attained and given to the project manager.
9. Topsoil and subsoil to be protected from contamination. This must be monitored on a monthly basis by a visual inspection of diesel/oil spillage and pollution prevention facilities.
10. Concrete and chemicals must be mixed on an impervious surface and provisions must be made to contain spillages or overflows into the soil.
11. Relevant departments and other emergency services must be contacted in order to deal with spillages and contamination of aquatic environments.
12. Soils must be kept free of petrochemical solutions that must be kept on site during construction. Spillage can result in a loss of soil functionality thus limiting the re-establishment of flora.
13. Soils must be kept free of petrochemical solutions that must be kept on site during construction. Spillage can result in a loss of soil functionality thus limiting the re-establishment of flora.

## 4.8 Traffic Management Plan

**Table 55:** Traffic Management Plan

<b>TRAFFIC MANAGEMENT PLAN</b>	
<b>MITIGATION MEASURES</b>	<ol style="list-style-type: none"> <li>1. A designated transport coordination manager must be appointed to oversee and manage the traffic safety officers. Additionally, the designated transport coordination manager must inform and keep up-to-date the interested and affected parties of all the activities taking place that may have a direct impact on them.</li> <li>2. A traffic safety officer must be nominated to make all the necessary arrangements to maintain the required traffic measures for the duration of the project. The safety officer must liaise daily with the transportation coordination manager to keep them apprised of the state of all the traffic arrangements.</li> <li>3. All construction traffic must comply with the legal load requirements as outlined in the National Road Traffic Act and National Road Traffic Regulations.</li> <li>4. Construction traffic entering the site along busy public roads must be limited to times when peak hour traffic can be avoided. The peak traffic occurs during 7h00 to 8h30, and 16h00 to 17h30. Construction traffic can also be restricted further to avoid travelling on public holidays, long weekends, or at night.</li> <li>5. During periods of high construction traffic entering and exiting the site, it is recommended that flagmen help direct the traffic. This will enable the safe movement of construction and public traffic at the entrance and reduce the number of potential conflicts.</li> <li>6. The South African Road Traffic Signs Manual (SARTSM), Volume 2, June 1999 is to be used for all traffic during the construction activities of the proposed project.</li> <li>7. Any damage caused by the construction vehicles to the existing road infrastructure must be repaired in kind, prior to the completion of the project.</li> <li>8. A dust suppression system for the gravel roads must be in place to prevent excessive dust from the traffic polluting the air.</li> <li>9. Trucks must stop at regular intervals to allow queuing vehicles to pass.</li> <li>10. All abnormal loads must be transported under a permit.</li> <li>11. A route study be undertaken to confirm the most appropriate route to site.</li> <li>12. Dust suppression techniques must be utilised to reduce the impact on air quality for the surrounding area.</li> </ol>

## 4.9 Transportation Management Plan

**Table 56:** Transportation Management Plan

<b>TRANSPORTATION MANAGEMENT PLAN</b>	
<b>MITIGATION MEASURES</b>	<ol style="list-style-type: none"> <li>1. For each convoy of abnormal vehicles/loads a designated safety officer must be nominated.</li> <li>2. All vehicles used during the transport of materials and in the construction activities are required to be roadworthy per the National Road Traffic Act (NRTA) and display all pertinent certificates as required.</li> <li>3. For any vehicles that operate under an exemption permit, a roadworthy certificate may not be required; however the exemption permit will require that the vehicle is fit for operation on public roadways.</li> <li>4. All vehicles travelling to and from the site must adhere to all laws imposed by the law enforcement agencies, and must comply with any requests made by the law enforcement officials.</li> <li>5. All construction vehicles that are entering the site must also be available via radio or telephone communication to the transport coordination manager. So that in the event of an emergency, all vehicles can be accounted for.</li> <li>6. During the delivery of the power line and substation components, the person in charge must be in communication with transport coordination manager, so that he/she may keep track and document the progress of the vehicles to facilitate any issues that may arise during the transportation phase.</li> <li>7. All vehicles must comply with the posted speed limits on public roads as well as the speed limits within the development.</li> <li>8. All abnormal vehicles and loads to be transported are required to have a valid permit before any trip is begun.</li> <li>9. SANRAL Western &amp; Southern Region will need to be contacted in order to obtain consent for the abnormal load transport on their roadways.</li> <li>10. An escort is required to accompany the abnormal vehicle to warn the normal travelling public and to promote the safe flow of traffic if the normal flow of traffic is disrupted by the abnormal vehicle.</li> <li>11. Construction vehicles delivering raw materials to the site must be covered to prevent any debris along the roads.</li> <li>12. A consolidated Traffic and Transport Management Plan, taking into account the final route selection must be prepared once the Project advances to the preliminary phase. This plan must ensure that vehicles arrive in a dispersed manner throughout the day to reduce the impact to other road users. The plan must also</li> </ol>

	<p>promote the use of car sharing, especially from Loeriesfontein and the construction camp. Methods to improve driver safety must also be outlined, e.g. the use of speed cameras or Average Speed Over Distance (ASOD) cameras along particular sections such as the R358 to Loeriesfontein. Furthermore, this plan must include measures to minimize the impact on local commuters so as not to disturb existing retail and commercial operations.</p>
--	---

The proposed !Xha Boom Substation, Linking Substation and 132kV power line are intrinsically linked to the proposed !Xha Boom Wind Farm, as the power line and substations will link the proposed wind farm to the national grid via the existing Helios substation. Additionally, a section of the power line corridor, and both substation site alternatives are located on the application site for the proposed !Xha Boom Wind Farm. As such, it must be noted that a Preliminary Transportation Study was conducted by SMEC South Africa which attempted to address all transport issues relating to the proposed !Xha Boom Wind Farm (currently undergoing a separate EIA process with the DEA reference no as **14/12/16/3/3/2/1018**).

## **4.10 Fire Management Plan**

The intent of a Fire Management Plan (FMP) is to provide fire safety requirements to ensure that the construction and operation of the proposed !Xha Boom Substation, Linking Substation and power line, which are defensible from wildfire and, in turn, do not represent a significant threat of ignition source for the surrounding native habitat.

It must be noted that during extreme fire conditions, there are no guarantees that a given structure will not burn. Precautions and mitigating measures identified in this plan are designed to reduce the likelihood that fire would impinge upon the proposed structures as well as minimise the impact of fires if they do occur. This FMP does not guarantee that fire will not occur in the area or that fire will not damage property or cause harm to persons or their property.

Mainstream will rely heavily on the co-operation and proactive participation between managers, employees and contractors to maintain a high level of Fire safety awareness at all times.

This management plan is also a reflection of Mainstream's commitment towards the constant safeguarding of employees against Fire hazards, whilst complying with the requirements of the Fire Safety Act, 6 of 2002 and Occupational Health and Safety Act, 85 of 1993.

### *4.10.1 Fire and Maintenance of Access Roads for Solar Facility*

- A primary access and escape route will be visible and known to all who visit the facility and will be controlled by a security gate.
- There will be other dedicated secondary gravel roads leading to/from the project site to/from the primary access.
- There will be more than one vehicular access gate leading into the project.
- An escape route map with safe gathering points needs to be visible at all the entrance gates/construction camps for anyone to familiarise themselves with upon entry (and will be provided prior to construction once the final facility layout and building plans have been approved by the appropriate department/authority).

#### 4.10.2 *Fire Safety Act, 6 of 2002*

A copy of the fire safety act is to be available at the facility for everyone's easy access purposes.

#### 4.10.3 *Principles of Fire Safety*

The aims of implementing measures to limit the incidences and spread of fire are:

- To ensure the safety of people, minimising loss of life and injury.
- To minimise loss of and damage to property and possessions.
- To minimise the negative impact on the environment.
- To safely and effectively extinguish fire when needed

#### 4.10.4 *Requirements in Terms of the South African Bureau of Standards (SABS)*

From a fire safety point of view, all buildings erected within the boundaries of South Africa must comply with the SABS 0400:1990- The application of the National Building Regulations. The following requirements are appropriate and can be adapted for planning and design of buildings. Any building must be so designed, constructed and equipped that in case of fire:

- The protection of occupants or users therein is ensured and that provision is made for the safe evacuation of such occupants or users.
- The spread and intensity of such fire within such buildings and the spread of fire to any other building will be minimised.
- Adequate means of access and equipment for detecting, fighting, controlling and extinguishing such fire are adopted.

#### 4.10.5 *Management Commitment*

It will be the responsibility of managers to:

- Enforce such measures as may be necessary in the interest of the preservation of employee's safety including safety against fire.
- Permit employees to perform work only once the precautionary measures are put in place.
- Provide the necessary supervision to staff to ensure that precautionary measures are maintained.
- Ensure that the staff are adequately trained in fire procedures.
- Ensure that all staff are informed regarding their scope of authority.
- Ensure that the FMP is reviewed and updated regularly to meet the projects needs at that particular point in time.



- Ensure that the firefighting equipment is regularly serviced.
- Make sure that the FMP forms part of the facility induction which will be made compulsory for each new member to the facility to attend.

#### 4.10.6 *Employees' Contribution to Fire Management*

The successful implementation of the FMP will require the full co-operation of every employee.

In this regard it will be expected of every employee to:

- Take care of the fire detection and fire protection systems and equipment.
- Carry out any lawful order given to him/her and obey the fire procedures laid down, or authorised thereto, by Mainstream in the interest of health and fire safety.
- Report any situation which may cause fire to the supervisor and/or Health and Safety Representative.
- Be able to make recommendations to the relevant Health and Safety representative who will take the recommendation into consideration and if agreed upon then implemented.

Co-operation will be expected from any other Contractor or subcontractor to ensure that any duty or requirement imposed on Mainstream, as the employer, through legislation, is complied with.

#### 4.10.7 *Fire Prevention/Control*

The following preliminary measures will be taken to try and prevent and/or control fires on site:

- Smoking and open flames will be prohibited in areas near flammable and/or combustible materials.
- Fire Fighting equipment will be sufficiently available on site and must comply with the relevant legislation.
- All equipment will be serviced annually and pressure tested every five years.

#### 4.10.8 *Response*

- The facility must at all times have emergency numbers readily available to all employees and staff. These include the fire department as well as emergency care numbers to make sure that fires are quickly extinguished when they occur and that the victims (if any) are medically treated and taken to a nearby hospital or clinic if needs be.
- The staff will be trained to use the firefighting equipment for small fires that can be contained but alternatively if the fire cannot be contained, the appropriate authorities must be contacted to assist in extinguishing the fire.

- If the fire cannot be contained, workers must evacuate the site in an orderly manner led by a trained Health and Safety representative.
- During construction phase, fire protection measures like placing fire extinguishers on site are compulsory before any hot work can commence or where any flammable substances are present.
- During operation phase, Fire protection equipment like Fire Extinguishers will be situated at carefully selected locations for easy access during an emergency.

#### 4.10.9 Management Plan

The following will form the key elements of the FMP:

- Legal Compliance
  - A work place that is safe and without risk to the health and safety of employees in compliance with the requirements of the Occupational Health and Safety Act 85 of 1993 and its regulations as well as the Fire Safety Act, 6 of 2002.
- Fire hazard identification and risk assessment
  - Identify any fire hazards and risks and then determine the extent and impact.
  - Endeavour to eliminate fire hazards and develop control measures to contain the fires.
- Fire Safety, Health and Environmental Proficiency
  - Ensure that employees are conversant with the potential fire hazards and the precautionary measures required with respect to these hazards through regular awareness training.
  - Incorporate and discuss Fire Safety into the daily Toolbox talks.
- Written Safe Word Procedures
  - Develop written safe work procedures for all fire high risks and provide the necessary training to employees if needs be.
- Training and Education
  - Include the fire management plan in all Health and Safety training and assessments and provide the necessary training and awareness to all categories of employees.
  - Provide awareness and training to all new employees including temporary employees and contractors on site.
- Prevention
  - Suitable preventative measures against exposure to hazards are an integral part of daily activities.
  - Personnel protective equipment must be provided for the protection of employees when necessary.
  - Corrective and/or fire preventative measures must be put in place.

- Elimination of Fire Incidents
  - The elimination of fire incidents, including injuries on duty to which employees and the public can be exposed to will be achieved through the proper investigation of any fire incidents. Factors which cause any fire incidences will be determined and then corrective and preventative measures will be developed and implemented in liaison with all relevant stakeholders.
  
- First Aid Kit
  - A first aid kit will be available on site which will contain all the necessary medication (e.g. pain medication) and equipment to pre-treat any fire injury depending on the magnitude of the injury. If the injury is too severe, the victim must be taken to the nearest hospital or clinic to be treated by professionals and not treated on site.
  - There will be a sufficient number of employees trained in first aid medical assistance in case of small controllable fire incidents occurring on site.
  
- Machinery, Plant and Equipment
  - All mechanical equipment will be safeguarded in order to protect the health and safety of persons that must be exposed to such equipment.
  - Regular maintenance of all equipment (including firefighting equipment) and inspections will be recorded.
  - Only equipment that is safe and in working condition will be used by the employees. Equipment is to be inspected every day before use.
  
- Sub-Contractors
  - Sub-contractors will sign an agreement with the Developer to ensure their compliance with the FMP.
  - Sub-contractors will work according to the Health and Fire Safety standards.

#### **4.11 Environmental Awareness Plan**

Legislation requires that a company who prepares an environmental management program must develop an environmental awareness plan describing the manner in which the company intends to inform his or her employees of any environmental risks which must result from their work and the manner in which the risks must be dealt with in order to avoid pollution or the degradation of the environment. In recognition of the need to protect our environment, environmental management should not only be seen as a legal obligation but also as a moral obligation.

This Environmental Awareness Plan is intended to create the required awareness and culture with personnel and contractors/service providers on environmental safety and health issues associated with the development activities.

#### 4.11.1 *Policy on Environmental Awareness*

This Environmental Awareness Plan must serve as the basis for the induction of all new employees (as well as contractors depending on the nature of their work on site) on matters as described herein and read in conjunction with the EMPr. The Plan will also be used to hone awareness of all employees on a continuous basis.

Specific environmental awareness performance criteria will also form part of the job descriptions of employees, to ensure diligence and full responsibility at all levels of the organisational work force.

#### 4.11.2 *Implementation of Environmental Awareness*

General environmental awareness will be fostered among the project's workforce to encourage the implementation of environmentally sound practices throughout the project's duration. This will ensure that environmental accidents are minimised and environmental compliance maximised.

Environmental awareness will be fostered in the following manner:

- Induction course for all workers on site, before commencing work on site.
- Refresher courses as and when required
- Daily toolbox talks with all workers on the site at the start of each day, where workers can be alerted to particular environmental concerns associated with their tasks for that day or the area/habitat in which they are working.
- Displaying of information posters and other environmental awareness material at the general assembly points.

#### 4.11.3 *Training and awareness*

The MC is to take responsibility for the management of their staff and subcontractors on the project site during the construction phase and supervise them closely at all times. The onus is on the MC to make sure that all their staff and subcontractors fully comprehend the contents of the EMPr. The MC must organise environmental awareness training programmes, which should be targeted at the two levels of employee: management and labour.

#### 4.11.4 Training of construction workers

All construction staff must receive basic training in environmental awareness, including the storage and handling of hazardous substances, minimisation of disturbance to sensitive areas, management of waste, and prevention of water pollution. They must be informed of how to recognise historical / archaeological artefacts that may be uncovered. They must also be apprised of the EMP's requirements. Environmental awareness training programmes need to be formulated for these employee levels and must comprise:

- A record of all names, positions and duties of staff to be trained;
- A framework for the training programmes;
- A summarised version of the training course(s); and
- An agenda for the delivery of the training courses.

Such programmes will set out the training requirements, which need to be conducted prior to any construction works occurring and will include:

- Acceptable behaviour with regard to flora and fauna;
- Management and minimising of waste, including waste separation;
- Maintenance of equipment to prevent the accidental discharge or spill of fuel, oil, lubricants, cement, mortar and other chemicals;
- Responsible handling of chemicals and spills;
- Environmental emergency procedures and incident reporting; and
- General code of conduct towards I&APs.

The ECO may be requested to provide additional on-site training (in a first language) in respect of environmental aspects that are unclear to the construction personnel. A translator may be required to assist with this additional training. The cost for the translator will be borne by the MC.

An example of the Environmental Awareness Presentation to be given is included in Annexure H.

## 5 CONCLUSION

The environmental and social impacts of the project were identified through the four project phases (pre-construction, construction, operation and decommissioning). Both positive and negative project impacts have been identified. The following section briefly describes some of the major impacts and proposed mitigation measures within each of the project phases.

## **5.1 Pre-Construction Phase**

The first site activities before mobilization of equipment will be a survey, required for final design of the power line and substation. There could be negative impacts on land associated with the construction of camps (temporary loss) and storage of construction materials. Expectations of improvement in livelihood among locals must be addressed through public participation. Construction contracts will include environmental monitoring and management procedures and requirements. These must be in place prior to the commencement of any construction activities.

## **5.2 Construction Phase**

This phase of the activity will have both positive and negative impacts. The positive impacts are employment opportunities offered to the construction workers and any other labourer who will be hired to provide their services during the construction phase. The negative impacts would include waste generation, accidents, health and safety, air, dust and noise pollution, vegetation clearance, soil erosion, socio-environmental issues, loss of vegetation, and compaction of soil. Most of the negative impacts are minor and temporary and the significance of the impacts can be greatly reduced by the implementation of mitigation measures, which are outlined in this EMPr. The contractor must ensure that all staff have adequate protective clothing and are adequately trained.

## **5.3 Operational Phase**

The proposed project will have minimal negative effects which mainly relates to loss of aesthetic value and habitat. The habitat that will be lost is not regarded as pristine and therefore, is not viewed as significant. Most of the negative impacts are minor and the significance of the impacts can be greatly reduced by the implementation of mitigation measures, which are outlined in this EMPr.

## **5.4 Decommissioning Phase**

As with any project, the facilities used in this project will have a lifetime after which they may no longer be cost effective to continue with operation. At that time, the project would be decommissioned, and the existing equipment removed.

Potential environmental impacts caused during decommissioning are those, which will be mitigated as provided by the Environmental Management Programme. These include: noise and emissions to the

surrounding environment, removal of hazardous waste and substances, fire, oil spills, wastes and public safety.

The disposal of materials from the decommissioned facility is not viewed as high risk. Much of the material would be recyclable (steel structures etc.) or inert (concrete foundations, etc.). These materials would however, need to be disposed of at a formal waste disposal or recycling centre.

Based on the above information, it is unlikely that the Project will have significant adverse social and environmental impacts. Most adverse impacts will be of a temporary nature during the construction phase and can be managed to acceptable levels with implementation of the recommended mitigation measures for the Project such that the overall benefits from the Project will greatly outweigh the few adverse impacts.

All the negative impacts could be easily mitigated. Generally, the proposed power line and substation will result in appreciable benefits to the people in the project area of influence and bring opportunities for development to the country.







# Annexure B

## Management of Soils: Guidelines

### Topsoil

- Source of topsoil
  - Topsoil must be stripped from all areas that are to be utilised during the construction period and where permanent structures and access is required. These areas will include temporary and permanent access roads, construction camps, and lay down areas. Topsoil must be stripped after clearing of woody vegetation and before excavation or construction commences.
  - The topsoil is regarded as the top 300mm of the soil profile irrespective of the fertility appearance, structure, agricultural potential, fertility and composition of the soil.
- Topsoil stripping
  - Soil must be stripped to a minimum depth of 150mm and maximum depth of 300mm or to the depth of bedrock where soil is shallower than 300mm. Herbaceous vegetation, overlying grass and other fine organic matter must not be removed from the stripped soil.
  - No topsoil which has been stripped must be buried or in any other way be rendered unsuitable for further use by mixing with spoil or by compaction using machinery.
  - Topsoil must preferably be stripped when it is in a dry condition in order to prevent compaction.
- Topsoil stockpiling
  - The Consulting Engineer or Environmental Control Officer must stockpile stripped topsoil in areas, which have been approved. Soil stockpiles must take the form of windrows.
  - To prevent erosion, material stockpiled for long periods (2 weeks) must be retained in a bermed area.
  - Topsoil, mulch and subsoil stockpiles must be placed in higher-lying areas of the site, and must not be positioned within stormwater channels or areas of ponding.
  - Topsoil stripped from different soil zones must be stockpiled separately and clearly identified as such. Under no circumstances must topsoil obtained from different soil zones be mixed.
  - Soil stockpiles must not be higher than 2m or stored for a period longer than one year. The slopes of soil stockpiles must not be steeper than 1 vertical to 2.5 horizontal.
  - No vehicles must be allowed access onto the stockpiles after they have been placed. Topsoil stockpiles must be clearly demarcated in order to prevent vehicle access and for later identification when required.
  - Soil stockpiles must not become contaminated with oil, diesel, petrol, garbage or any other material, which may inhibit the later growth of vegetation in the soil.

- After topsoil removal has been completed, the Contractor must apply soil conservation measures to the stockpiles where and as directed by the Consulting Engineer or Environmental Control Officer. This must include the use of erosion control fabric or grass seeding.
- Topsoil replacement
  - Topsoil must be replaced to a minimum depth of 75mm over all areas where it has been stripped and over disused borrow pits, after construction in those areas has ceased. Topsoil placement must follow as soon as construction in an area has ceased.
  - All areas onto which topsoil is to be spread must be graded to the approximate original landform with maximum slopes of 1:25 and must be ripped prior to topsoil placement. The entire area must be ripped parallel to the contours to a minimum depth of 300mm.
  - Topsoil must be placed in the same soil zone from which it had been stripped. However, if there is insufficient topsoil available from a particular soil zone to produce the minimum specified depth, topsoil must be brought from other soil zones at the approval of the Consulting Engineer or Environmental Control Officer.
  - Where topsoil that has been stripped by the Contractor is insufficient to provide the minimum specified depth, the Contractor must obtain suitable substitute material from other sources at no cost to the employer. The suitability of the substitute material must be determined by means of soil analyses, which are acceptable to the Consulting Engineer or Environmental Control Officer.
  - No vehicles must be allowed access onto or through topsoil after it has been reinstated.
  - After topsoil reinstatement is complete, cleared and stockpiled vegetative matter must be spread randomly by hand over the top soiled area. The vegetative material must be replaced on the areas from where it has been removed.

## Annexure C

# Eskom Requirements for Work in or near Eskom Servitudes

- 1) Eskom's rights and services must be acknowledged and respected at all times.
- 2) Eskom must at all times retain unobstructed access to and egress from its servitudes.
- 3) Eskom's consent does not relieve the developer from obtaining the necessary statutory, land owner or municipal approvals.
- 4) The applicant will adhere to all relevant environmental legislation. Any cost incurred by Eskom as a result of non-compliance to any relevant environmental legislation will be charged to the developer.
- 5) Eskom's underground cables must be placed in sleeves encased in concrete across the width of the servitude, at the applicant's expense. This is only required in certain situations such as where frequent excavations might occur in the cable area. Materials to be used and relevant dimensions must be determined by the internal assessor and by Project Engineering.
- 6) All underground cables in or crossing Eskom overhead sub-transmission and transmission servitudes must be protected by concrete slabs placed 300mm above cables with danger tape markings and cable route/position indicated by standard concrete monuments.
- 7) No construction or excavation work must be executed within 11 metres from any Eskom power line structure, and/or within 11 metres from any stay wire.
- 8) All work within Eskom's servitude areas must comply with the relevant Eskom standards in force at the time.
- 9) If Eskom has to incur any expenditure in order to comply with statutory clearances or other regulations as a result of the developer's activities or because of the presence of his equipment or installation within the servitude restriction area, the developer must pay such costs to Eskom on demand.
- 10) The use of explosives of any type within 500 metres of Eskom's services must only occur with Eskom's previous written permission. If such permission is granted the developer must give at least fourteen working days prior notice of the commencement of blasting. This allows time for arrangements to be made for supervision and/or precautionary instructions to be issued in terms of the blasting process. It is advisable to make application separately in this regard.

- 11) Changes in ground level must not infringe statutory ground to conductor clearances or statutory visibility clearances. After any changes in ground level, the surface must be rehabilitated and stabilised so as to prevent erosion. The measures taken must be to Eskom's satisfaction.
- 12) Eskom must not be liable for the death of or injury to any person or for the loss of or damage to any property whether as a result of the encroachment or of the use of the servitude area by the developer, his/her agent, contractors, employees, successors in title, and assignees. The developer indemnifies Eskom against loss, claims or damages including claims pertaining to consequential damages by third parties and whether as a result of damage to or interruption of or interference with Eskom's services or apparatus or otherwise. Eskom will not be held responsible for damage to the developer's equipment.
- 13) No mechanical equipment, including mechanical excavators or high lifting machinery, must be used in the vicinity of Eskom's apparatus and/or services, without prior written permission having been granted by Eskom. If such permission is granted the developer must give at least seven working days' notice prior to the commencement of work to Mr. Cyril Nuttall (Tel. 013 693 4144 Fax: 013 693 4180) at Middelburg Technical Service Centre, Eskom Distribution. This allows time for arrangements to be made for supervision and/or precautionary instructions to be issued.

Note: Where an electrical outage is required, at least fourteen work days are required to arrange it.

- 14) No work must commence unless Eskom has received the applicant's written acceptance of the conditions specified in the letter of consent and/or permit. The applicant or his/her contractor on site must at all times be in possession of the letter of consent. Should the site agent or contractor on site not be able to produce the required approval on inspection all site activities will be stopped.
- 15) Eskom's rights and duties in the servitude must be accepted as having prior right at all times and must not be obstructed or interfered with.
- 16) Under no circumstances must rubble, earth or other material be dumped within the servitude restriction area. The developer must maintain the area concerned to Eskom's satisfaction. The developer must be liable to Eskom for the cost of any remedial action which has to be carried out by Eskom.
- 17) The clearances between Eskom's live electrical equipment and the proposed construction work must be observed as stipulated by Regulation 15 of the Electrical Machinery Regulations of the Occupational Health and Safety Act, 1993 (Act 85 of 1993).
- 18) Equipment must be regarded electrically live and therefore dangerous at all times.
- 19) In spite of the restrictions stipulated by Regulation 15 of the Electrical Machinery Regulations of the Occupational Health and Safety Act, 1993 (Act 85 of 1993), as an additional safety precaution,

Eskom will not approve the erection of houses, or structures occupied or frequented by human beings, under the power lines or within the servitude restriction area.

- 20) Eskom must stipulate any additional requirements to eliminate any possible exposure to Customers or Public coming into contact or be exposed to any dangers of Eskom plant.
- 21) It is required of the developer to familiarise himself with all safety hazards related to Electrical plant.
- 22) Any third party servitudes encroaching on Eskom servitudes must be registered against Eskom's title deed at the developer's own cost. If such a servitude is brought into being, its existence must be endorsed on the Eskom servitude deed concerned, while the third party's servitude deed must also include the rights of the affected Eskom servitude.
- 23) In the event of an application for the subdivision of land or rezoning it is essential that the conductor to ground clearance of an overhead line be confirmed. The conductor to ground clearance specified for land outside townships varies vastly from that inside townships. It could thus be necessary to increase the height of power lines to remain within the Regulations of the OHS Act.
- 24) Eskom (responsible professional engineer) requires:
  - Proposed design, longitudinal section included in letter of application,
  - As-built plans with co-ordinates, once constructed,
  - Ownership of the power line must be clearly marked,
  - Where services run parallel to Eskom's, the applicant's power line will maintain a separation distance, centre line to centre line. The distance must be determined by the internal assessor and must comply with access requirements and Occupation Health and Safety Act clearances and Eskom standards
- 25) If such permission is granted, the applicant must give at least fourteen work day's prior notice of the commencement of work to Mr. Cyril Nuttall (Tel. 013 693 4144 Fax: 013 693 4180) at Middelburg Technical Service Centre, Eskom Distribution. This allows time for arrangements to be made for supervision of and/or precautionary instructions to be issued in terms of the overhead power line construction.
- 26) Should the applicant or his contractor damage any of Eskom services during commencement of any work whatsoever, then Eskom's 24 hour Contact Centre Tel: 086 000 1414 must be dialed immediately to report the incident.

Any relocation of Eskom's services, due to the proposed prospecting, will be for the account of the Applicant. The Applicant will also be responsible for granting Eskom an alternative route for the power line. The Eskom Customer Contact Centre at 08600 37566 must be contacted in connection with any line deviation and costs.

John Geeringh (Pr Sci Nat)

Senior Environmental Advisor  
Eskom GC: Land Development

And

Louise Human  
Land Development and Environmental Manager

## **Annexure D**

### Heritage Management Guidelines and Plan



## GENERAL MANAGEMENT GUIDELINES

1.

**In the event that an area previously not included in an archaeological or cultural resources survey is to be disturbed, the SAHRA needs to be contacted. An enquiry must be lodged with them into the necessity for a Heritage Impact Assessment.**

2. In the event that a further heritage assessment is required it is advisable to utilise a qualified heritage practitioner, preferably registered with the Cultural Resources Management Section (CRM) of the Association of Southern African Professional Archaeologists (ASAPA).

This survey and evaluation must include:

- (a) The identification and mapping of all heritage resources in the area affected;
- (b) An assessment of the significance of such resources in terms of the heritage assessment criteria set out in section 6 (2) or prescribed under section 7 of the National Heritage Resources Act;
- (c) An assessment of the impact of the development on such heritage resources;
- (d) An evaluation of the impact of the development on heritage resources relative to the sustainable social and economic benefits to be derived from the development;
- (e) The results of consultation with communities affected by the proposed development and other interested parties regarding the impact of the development on heritage resources;
- (f) If heritage resources will be adversely affected by the proposed development, the consideration of alternatives; and
- (g) Plans for mitigation of any adverse effects during and after the completion of the proposed development.

3. It is advisable that an information section on cultural resources be included in the SHE training given to contractors involved in surface earthmoving activities. These sections must include basic information on:

- a. Heritage;
- b. Graves;
- c. Archaeological finds; and
- d. Historical Structures.

This module must be tailor made to include all possible finds that could be expected in that area of construction.

Possible finds include:

- a. Open air Stone Age scatters, disturbed during vegetation clearing. This will include stone tools.
  - b. Palaeontological deposits such as bone, and teeth in fluvial riverbank deposits.
4. In the event that a possible find is discovered during construction, all activities must be halted in the area of the discovery and a qualified archaeologist contacted.
5. The archaeologist needs to evaluate the finds on site and make recommendations towards possible mitigation measures.
6. If mitigation is necessary, an application for a rescue permit must be lodged with SAHRA.

7. After mitigation, an application must be lodged with SAHRA for a destruction permit. This application must be supported by the mitigation report generated during the rescue excavation. Only after the permit is issued may such a site be destroyed.
8. If during the initial survey sites of cultural significance are discovered, it will be necessary to develop a management plan for the preservation, documentation or destruction of such a site. Such a program must include an archaeological/palaeontological monitoring programme, timeframe and agreed upon schedule of actions between the company and the archaeologist.
9. In the event that human remains are uncovered, or previously unknown graves are discovered, a qualified archaeologist needs to be contacted and an evaluation of the finds made.
10. If the remains are to be exhumed and relocated, the relocation procedures as accepted by SAHRA need to be followed. This includes an extensive social consultation process.



**SiVEST Environmental Division**

51 Wessels Road, Rivonia. 2128. South Africa  
PO Box 2921, Rivonia. 2128. South Africa

Tel 27 11 798 0600  
Fax 27 11 803 7272  
Email [info@sivest.co.za](mailto:info@sivest.co.za)  
[www.sivest.co.za](http://www.sivest.co.za)

Contact Person: Andrea Gibb  
Cell No.: 27 72 587 6525  
Email: [andrea@sivest.co.za](mailto:andrea@sivest.co.za)



## **Appendix 9**

### **Additional Information**





## **Appendix 9A**

### **Project Coordinates**





## PROJECT COORDINATES

### COORDINATES FOR ALTERNATIVES WHICH WERE INVESTIGATED / ASSESSED:

!XHA BOOM ON-SITE ESKOM SUBSTATION SITE ALTERNATIVES			
ALTERNATIVE	AREA (HECTARES)	CENTRE POINT COORDINATES	
		SOUTH	EAST
Option 1	7.5	S30 17 41.614	E19 16 50.509
Option 2	7.5	S30 17 13.641	E19 15 55.620

LINKING SUBSTATION SITE ALTERNATIVES			
ALTERNATIVE	AREA (HECTARES)	CENTRE POINT COORDINATES	
		SOUTH	EAST
Option 1	3	S30 19 23.315	E19 20 4.455
Option 2	3	S30 18 46.373	E19 18 45.622

!XHA BOOM 132kV POWER LINE CORRIDOR ALTERNATIVES				
CENTRE LINE COORDINATES (DD MM SS.sss)				
CORRIDOR ALTERNATIVE	START POINT	MIDDLE POINT	END POINT (HELIOS SUBSTATION)	APPROX LENGTH (KM)
Option 1	S30 17 8.659	S30 20 6.409	S30 29 58.002	52.20
	E19 15 47.319	E19 27 39.274	E19 33 37.699	
Option 2	S30 17 8.659	S30 20 25.669	S30 29 58.002	52.80
	E19 15 47.319	E19 27 34.292	E19 33 37.699	
Option 3	S30 17 8.659	S30 24 23.227	S30 29 58.002	47.00



	E19 15 47.319	E19 24 44.885	E19 33 37.699	
Option 4	S30 17 8.659	S30 19 3.132	S30 29 58.002	53.40
	E19 15 47.319	E19 29 30.547	E19 33 37.699	

<b>!XHA BOOM 132kV POWER LINE CORRIDOR OPTION 1 – CENTRE LINE</b>		
<b>COORDINATES AT BEND POINTS (DD MM SS.sss)</b>		
<b>POINT</b>	<b>SOUTH</b>	<b>EAST</b>
1 (Start)	S30 17 8.659	E19 15 47.319
2	S30 19 48.457	E19 21 4.551
<b>3</b>	S30 17 44.939	E19 22 5.093
4	S30 19 3.332	E19 27 55.703
5	S30 24 25.510	E19 26 32.264
6	S30 27 16.811	E19 27 22.109
7	S30 28 14.635	E19 29 59.801
8	S30 30 56.963	E19 32 14.558
9	S30 30 6.570	E19 33 9.965
10	S30 29 59.917	E19 33 26.116
11 (Helios MTS)	S30 29 58.002	E19 33 37.699

<b>!XHA BOOM 132kV POWER LINE CORRIDOR OPTION 2 – CENTRE LINE</b>		
<b>COORDINATES AT BEND POINTS (DD MM SS.sss)</b>		
<b>POINT</b>	<b>SOUTH</b>	<b>EAST</b>
1 (Start)	S30 17 8.659	E19 15 47.319

2	S30 19 48.457	E19 21 4.551
3	S30 17 44.939	E19 22 5.093
4	S30 19 3.332	E19 27 55.703
5	S30 24 25.510	E19 26 32.264
6	S30 25 4.843	E19 29 40.243
7	S30 26 1.013	E19 33 32.381
8	S30 26 21.195	E19 33 30.197
9	S30 27 34.097	E19 34 18.366
10	S30 28 0.765	E19 34 11.814
11	S30 28 41.491	E19 33 32.932
12	S30 29 47.447	E19 33 30.716
13 (Helios MTS)	S30 29 58.002	E19 33 37.699

<b>IXHA BOOM 132kV POWER LINE CORRIDOR OPTION 3 – CENTRE LINE</b>		
<b>COORDINATES AT BEND POINTS (DD MM SS.sss)</b>		
<b>POINT</b>	<b>SOUTH</b>	<b>EAST</b>
1 (Start)	S30 17 8.659	E19 15 47.319
2	S30 19 48.457	E19 21 4.551
3	S30 18 53.285	E19 21 31.626
4	S30 19 21.390	E19 22 40.680
5	S30 21 21.781	E19 23 12.001
6	S30 26 39.103	E19 25 54.499
7	S30 27 56.682	E19 27 16.488

8	S30 31 54.501	E19 29 14.772
9	S30 30 46.164	E19 32 4.981
10	S30 30 55.689	E19 32 14.142
11	S30 30 6.485	E19 33 10.101
12	S30 29 59.917	E19 33 26.116
13 (Helios MTS)	S30 29 58.002	E19 33 37.699

<b>IXHA BOOM 132kV POWER LINE CORRIDOR OPTION 4 – CENTRE LINE</b>		
<b>COORDINATES AT BEND POINTS (DD MM SS.sss)</b>		
<b>POINT</b>	<b>SOUTH</b>	<b>EAST</b>
1 (Start)	S30 17 8.659	E19 15 47.319
2	30 19 48.457	19 21 4.551
3	30 17 44.939	19 22 5.093
4	30 19 3.332	19 27 55.703
5	30 19 1.072	19 32 1.539
6	30 20 41.708	19 34 58.099
7	30 25 59.926	19 33 27.885
8	30 26 1.013	19 33 32.381
9	30 26 21.195	19 33 30.197
10	30 27 34.097	19 34 18.366
11	30 28 0.765	19 34 11.814
12	30 28 41.491	19 33 32.932

13	30 29 47.447	19 33 30.716
14	30 29 58.002	19 33 37.699
15 (Helios MTS)	S30 29 58.002	E19 33 37.699

## COORDINATES FOR SELECTED PREFERRED ALTERNATIVES:

PREFERRED !XHA BOOM ON-SITE Eskom SUBSTATION SITE			
ALTERNATIVE	AREA (HECTARES)	CENTRE POINT COORDINATES	
		SOUTH	EAST
Option 1	7.5	S30 17 41.614	E19 16 50.509

PREFERRED LINKING SUBSTATION SITE			
ALTERNATIVE	AREA (HECTARES)	CENTRE POINT COORDINATES	
		SOUTH	EAST
Option 1	3	S30 19 23.315	E19 20 4.455

PREFERRED !XHA BOOM 132kV POWER LINE CORRIDOR				
CENTRE LINE COORDINATES (DD MM SS.sss)				
CORRIDOR ALTERNATIVE	START POINT	MIDDLE POINT	END POINT (HELIOS SUBSTATION)	APPROX LENGTH (KM)
Option 4	S30 17 8.659	S30 19 3.132	S30 29 58.002	53.40
	E19 15 47.319	E19 29 30.547	E19 33 37.699	

PREFERRED !XHA BOOM 132kV POWER LINE CORRIDOR (I.E. OPTION 4) – CENTRE LINE		
COORDINATES AT BEND POINTS (DD MM SS.sss)		
POINT	SOUTH	EAST
1 (Start)	S30 17 8.659	E19 15 47.319
2	30 19 48.457	19 21 4.551
3	30 17 44.939	19 22 5.093
4	30 19 3.332	19 27 55.703

5	30 19 1.072	19 32 1.539
6	30 20 41.708	19 34 58.099
7	30 25 59.926	19 33 27.885
8	30 26 1.013	19 33 32.381
9	30 26 21.195	19 33 30.197
10	30 27 34.097	19 34 18.366
11	30 28 0.765	19 34 11.814
12	30 28 41.491	19 33 32.932
13	30 29 47.447	19 33 30.716
14	30 29 58.002	19 33 37.699
15 (Helios MTS)	S30 29 58.002	E19 33 37.699





## **Appendix 9B**

### **WinDeeds**





# Deeds Office Property

BUCHU FONTEIN, 184, 0 (CAPE TOWN)

## GENERAL INFORMATION

Deeds Office CAPE TOWN  
Date Requested 2016/02/17 16:38  
Information Source DEEDS OFFICE  
Reference -



## PROPERTY INFORMATION

Property Type FARM  
Farm Name BUCHU FONTEIN  
Farm Number 184  
Portion Number 0  
Local Authority CALVINIA DC  
Registration Division CALVINIA RD  
Province NORTHERN CAPE  
Diagram Deed CVQ25-9/1907  
Extent 9058.7209H  
Previous Description -  
LPI Code C01500000000018400000

## OWNER INFORMATION

### Owner 1 of 7

Person Type PRIVATE PERSON  
Name VERSFELD FREDERICK JOHANN  
ID Number 4606115045080  
Title Deed T161/2011  
Registration Date 2011/01/04  
Purchase Price (R) 10,001  
Purchase Date 1988/01/01  
Share 0.083333 \*  
Microfilm Reference  
Multiple Properties NO  
Multiple Owners YES

### Owner 2 of 7

Person Type PRIVATE PERSON  
Name VERSFELD NICOLAAS CHARLES  
ID Number 5710085156080  
Title Deed T161/2011  
Registration Date 2011/01/04  
Purchase Price (R) 10,001  
Purchase Date 1988/01/01  
Share 0.083333 \*  
Microfilm Reference  
Multiple Properties NO  
Multiple Owners YES

**Owner 3 of 7**

Person Type	PRIVATE PERSON
Name	VERSFELD PHILIP ADRIAN
ID Number	6007185073086
Title Deed	T161/2011
Registration Date	2011/01/04
Purchase Price (R)	10,001
Purchase Date	1988/01/01
Share	0.083333 *
Microfilm Reference	
Multiple Properties	NO
Multiple Owners	YES

**Owner 4 of 7**

Person Type	PRIVATE PERSON
Name	VERSFELD PATRICIA
ID Number	6305140041085
Title Deed	T161/2011
Registration Date	2011/01/04
Purchase Price (R)	10,001
Purchase Date	1988/01/01
Share	*
Microfilm Reference	
Multiple Properties	NO
Multiple Owners	YES

**Owner 5 of 7**

Person Type	PRIVATE PERSON
Name	VERSFELD FREDERICK JOHANN
ID Number	4606115045080
Title Deed	T27171/1976
Registration Date	1976/09/01
Purchase Price (R)	-
Purchase Date	-
Share	0.250000
Microfilm Reference	2007 1252 3111
Multiple Properties	NO
Multiple Owners	NO

**Owner 6 of 7**

Person Type	PRIVATE PERSON
Name	VERSFELD NICHOLAS CHARLES
ID Number	5710085156080
Title Deed	T27171/1976
Registration Date	1976/09/01
Purchase Price (R)	-
Purchase Date	-
Share	0.250000
Microfilm Reference	2007 1252 3111
Multiple Properties	NO
Multiple Owners	NO

**Owner 7 of 7**

Person Type	PRIVATE PERSON
Name	VERSFELD PHILIP ADRIAN
ID Number	6007185073086
Title Deed	T27171/1976
Registration Date	1976/09/01
Purchase Price (R)	-
Purchase Date	-
Share	0.250000
Microfilm Reference	2007 1252 3111
Multiple Properties	NO
Multiple Owners	NO

**ENDORSEMENTS (4)**

#	Document	Institution	Amount (R)	Microfilm
1	K448/1982S	VERSFELD HESTER MARIE	UNKNOWN	
2	VA1114/97-27171/76T	-	UNKNOWN	
3	VA4312/1997	K853/76S	UNKNOWN	1998 0113 2035
4	FARM CV 184	-	UNKNOWN	1985 0013 2035

**HISTORIC DOCUMENTS (2)**

#	Document	Owner	Amount (R)	Microfilm
1	K853/1976S	-	UNKNOWN	2007 1250 4726
2	T27171/1976	VERSFELD HUGH ANTHONY	UNKNOWN	2007 1252 3111

**DISCLAIMER**

This report contains information gathered from our suppliers and we do not make any representations about the accuracy of the data displayed nor do we accept responsibility for inaccurate data. WinDeed will not be liable for any damage caused by reliance on this report. This report is subject to the terms and conditions of the [WinDeed End User Licence Agreement \(EULA\)](#).

# Deeds Office Property

GRAS KOPPIES, 176, 1 (CAPE TOWN)

## GENERAL INFORMATION

**Deeds Office** CAPE TOWN  
**Date Requested** 2016/02/17 16:34  
**Information Source** DEEDS OFFICE  
**Reference** -



## PROPERTY INFORMATION

**Property Type** FARM  
**Farm Name** GRAS KOPPIES  
**Farm Number** 176  
**Portion Number** 1  
**Local Authority** CALVINIA DC  
**Registration Division** CALVINIA RD  
**Province** NORTHERN CAPE  
**Diagram Deed** T15964/1962  
**Extent** 4766,1564HA  
**Previous Description** -  
**LPI Code** C01500000000017600001

## OWNER INFORMATION

### Owner 1 of 1

**Person Type** PRIVATE PERSON  
**Name** NEL JACOBUS NICOLAAS  
**ID Number** 4106175056085  
**Title Deed** T30990/1979  
**Registration Date** 1979/10/26  
**Purchase Price (R)** -  
**Purchase Date** -  
**Share**  
**Microfilm Reference** 2005 0120 0239  
**Multiple Properties** NO  
**Multiple Owners** NO

## ENDORSEMENTS (2)

#	Document	Institution	Amount (R)	Microfilm
1	K1267/2002S	-	UNKNOWN	2003 0182 3593
2	FARM CV 176/1	-	UNKNOWN	1985 0013 1988

## HISTORIC DOCUMENTS (2)

#	Document	Owner	Amount (R)	Microfilm
1	B29080/1979	-	UNKNOWN	2001 0023 3991
2	B29079/1979	-	UNKNOWN	2005 0120 0238

## DISCLAIMER

This report contains information gathered from our suppliers and we do not make any representations about the accuracy of the data displayed nor do we accept responsibility for inaccurate data. WinDeed will not be liable for any damage caused by reliance on this report. This report is subject to the terms and conditions of the [WinDeed End User Licence Agreement \(EULA\)](#).

# Deeds Office Property



KARREE DOORN PAN, 214, 1 (CAPE TOWN)

## GENERAL INFORMATION

Deeds Office CAPE TOWN  
 Date Requested 2016/02/17 16:39  
 Information Source DEEDS OFFICE  
 Reference -



## PROPERTY INFORMATION

Property Type FARM  
 Farm Name KARREE DOORN PAN  
 Farm Number 214  
 Portion Number 1  
 Local Authority CALVINIA DC  
 Registration Division CALVINIA RD  
 Province NORTHERN CAPE  
 Diagram Deed T4502/1977  
 Extent 5094.2309H  
 Previous Description -  
 LPI Code C0150000000021400001

## OWNER INFORMATION

### Owner 1 of 1

Person Type PRIVATE PERSON  
 Name LOMBARD GERT JOHANNES  
 ID Number 4804015017081  
 Title Deed T12960/1989  
 Registration Date 1989/03/07  
 Purchase Price (R) 175,000  
 Purchase Date 1988/02/01  
 Share  
 Microfilm Reference 2003 0146 3526  
 Multiple Properties NO  
 Multiple Owners NO

## ENDORSEMENTS (3)

#	Document	Institution	Amount (R)	Microfilm
1	K1212/2002S	-	UNKNOWN	2003 0146 3532
2	K811/2015L	BUSINESS VENTURE INV NO 1788 PTY LTD	UNKNOWN	
3	FARM CV 214/1	-	UNKNOWN	1985 0013 2185

## HISTORIC DOCUMENTS (4)

#	Document	Owner	Amount (R)	Microfilm
1	B36994/1990	R S A	UNKNOWN	1999 0453 3227
2	B48764/1989	LANDBANK	UNKNOWN	2003 0146 3561
3	B30536/1999	-	UNKNOWN	2003 0146 3577
4	T4502/1977	SPANGENBERG WILLEM ADRIAAN	UNKNOWN	1989 0350 0256

## DISCLAIMER

This report contains information gathered from our suppliers and we do not make any representations about the accuracy of the data displayed nor do we accept responsibility for inaccurate data. WinDeed will not be liable for any damage caused by reliance on this report. This report is subject to the terms and conditions of the [WinDeed End User Licence Agreement \(EULA\)](#).

## Deeds Office Property



AAN DE KARREE DOORN PAN, 213, 2 (CAPE TOWN)

## GENERAL INFORMATION

Deeds Office CAPE TOWN  
 Date Requested 2016/02/17 16:41  
 Information Source DEEDS OFFICE  
 Reference -



## PROPERTY INFORMATION

Property Type FARM  
 Farm Name AAN DE KARREE DOORN PAN  
 Farm Number 213  
 Portion Number 2  
 Local Authority CALVINIA DC  
 Registration Division CALVINIA RD  
 Province NORTHERN CAPE  
 Diagram Deed T15441/1955  
 Extent 1902.8078H  
 Previous Description -  
 LPI Code C01500000000021300002

## OWNER INFORMATION

## Owner 1 of 1

Company Type TRUST  
 Name ALBERT LINTVELT FAMILIE TRUST  
 Registration Number 137/2010  
 Title Deed T62558/2010  
 Registration Date 2010/11/17  
 Purchase Price (R) 1,520,060  
 Purchase Date 2010/09/27  
 Share  
 Microfilm Reference  
 Multiple Properties NO  
 Multiple Owners NO

## ENDORSEMENTS (7)

#	Document	Institution	Amount (R)	Microfilm
1	B7470/2015	BOWWOOD & MAIN NO 107 R F PTY LTD	3,678,000,000	
2	EX840/1985-1/3/1985-	49368/1984T	UNKNOWN	
3	K683/2014L	SOUTH AFRICA MAINSTREAM RENEWABLE POWER LOERIESFONTEIN 2 PTY LTD	UNKNOWN	
4	K684/2014S	-	UNKNOWN	
5	K685/2014S	-	UNKNOWN	
6	VA1119/2015	SOUTH AFRICA MAINSTREAM RENEWABLE POWER LOERIESFONTEIN 2 PTY LTD	UNKNOWN	
7	FARM CV 213/2	-	UNKNOWN	1985 0013 2180

## HISTORIC DOCUMENTS (4)

#	Document	Owner	Amount (R)	Microfilm
1	B40712/1984	LAND EN LANBOUBANK	UNKNOWN	1998 0517 2049
2	T20982/1974	LINTVELT IZAK JACOBUS	UNKNOWN	
3	T49368/1984	LINTVELT ALBERT JACOBUS	60,300	1998 0804 4809
4	T49368/1984	LINTVELT HELENA HERMINA	SECT 45	1998 0804 4809

**DISCLAIMER**

This report contains information gathered from our suppliers and we do not make any representations about the accuracy of the data displayed nor do we accept responsibility for inaccurate data. WinDeed will not be liable for any damage caused by reliance on this report. This report is subject to the terms and conditions of the [WinDeed End User Licence Agreement \(EULA\)](#).



## Deeds Office Property

AAN DE KARREE DOORN PAN, 213, 0 (REMAINING EXTENT) (CAPE TOWN)

## GENERAL INFORMATION

Deeds Office CAPE TOWN  
 Date Requested 2016/02/17 16:40  
 Information Source DEEDS OFFICE  
 Reference -



## PROPERTY INFORMATION

Property Type FARM  
 Farm Name AAN DE KARREE DOORN PAN  
 Farm Number 213  
 Portion Number 0 (REMAINING EXTENT)  
 Local Authority CALVINIA DC  
 Registration Division CALVINIA RD  
 Province NORTHERN CAPE  
 Diagram Deed CVQ31-19/1915  
 Extent 2529.0517H  
 Previous Description (\*10348M 234SQRD)  
 LPI Code C01500000000021300000

## OWNER INFORMATION

## Owner 1 of 1

Person Type PRIVATE PERSON  
 Name LOMBARD GERT JOHANNES  
 ID Number 4804015017081  
 Title Deed T41783/1984  
 Registration Date 1984/08/21  
 Purchase Price (R) 71,586  
 Purchase Date 1984/03/29  
 Share  
 Microfilm Reference 2003 0146 3519  
 Multiple Properties NO  
 Multiple Owners NO

## ENDORSEMENTS (5)

#	Document	Institution	Amount (R)	Microfilm
1	K1212/2002S	-	UNKNOWN	2003 0146 3532
2	K186/1977S	-	UNKNOWN	
3	K827/2015L	BUSINESS VENTURE INV NO 1788 PTY LTD	UNKNOWN	
4	FARM CV 213	-	UNKNOWN	1985 0013 2175
5	PTNS CV RD 213/1-2	-	UNKNOWN	

## HISTORIC DOCUMENTS (5)

#	Document	Owner	Amount (R)	Microfilm
1	B36994/1990	R S A	UNKNOWN	1999 0453 3227
2	B48764/1989	LANDBANK	UNKNOWN	2003 0146 3561
3	B30536/1999	-	UNKNOWN	2003 0146 3577
4	T2832/1967	LINTVELT IZAK JACOBUS 1/2	UNKNOWN	
5	T37319/1974	LINTVELT IZAK JACOBUS 1/2	UNKNOWN	

**DISCLAIMER**

This report contains information gathered from our suppliers and we do not make any representations about the accuracy of the data displayed nor do we accept responsibility for inaccurate data. WinDeed will not be liable for any damage caused by reliance on this report. This report is subject to the terms and conditions of the [WinDeed End User Licence Agreement \(EULA\)](#).

# Deeds Office Property



SOUS, 226, 0 (REMAINING EXTENT) (CAPE TOWN)

## GENERAL INFORMATION

Deeds Office CAPE TOWN  
 Date Requested 2016/02/26 11:16  
 Information Source DEEDS OFFICE  
 Reference -



## PROPERTY INFORMATION

Property Type FARM  
 Farm Name SOUS  
 Farm Number 226  
 Portion Number 0 (REMAINING EXTENT)  
 Local Authority CALVINIA DC  
 Registration Division CALVINIA RD  
 Province NORTHERN CAPE  
 Diagram Deed CVQ23-9/1902  
 Extent 9084.7736H  
 Previous Description (\*10684M474R)  
 LPI Code C01500000000022600000

## OWNER INFORMATION

### Owner 1 of 1

Company Type TRUST  
 Name RONA RUPERT TRUST  
 Registration Number  
 Title Deed T42738/1984  
 Registration Date 1984/08/24  
 Purchase Price (R) 68,240  
 Purchase Date 1983/12/29  
 Share  
 Microfilm Reference 2003 0616 1869  
 Multiple Properties NO  
 Multiple Owners NO

## ENDORSEMENTS (16)

#	Document	Institution	Amount (R)	Microfilm
1	B7467/2015	BOWWOOD & MAIN NO 106 R F PTY LTD	3,842,000,000	
2	EX255/1974-1206/962T	-	UNKNOWN	
3	K19/1976S	-	UNKNOWN	
4	K507/2003S	-	UNKNOWN	2003 0616 1877
5	K581/1981S	-	UNKNOWN	
6	K701/2014S	-	UNKNOWN	
7	K702/2014S	-	UNKNOWN	
8	K700/2014L	SOUTH AFRICA MAINSTREAM RENEWABLE POWER KHOBAB WIND PTY LTY	UNKNOWN	
9	K703/2014S	-	UNKNOWN	
10	K704/2014S	-	UNKNOWN	
11	K818/1978S	-	UNKNOWN	
12	K819/1978S	-	UNKNOWN	
13	K820/1978S	-	UNKNOWN	
14	K947/1977S	-	UNKNOWN	
15	FARM CV 226	-	UNKNOWN	1985 0013 2242
16	PTNS CV RD 226/1-2	-	UNKNOWN	

**HISTORIC DOCUMENTS (2)**

#	Document	Owner	Amount (R)	Microfilm
1	I-892/2013C	-	UNKNOWN	
2	T1206/1962	DAVEL JACOBUS STEFANUS	UNKNOWN	

**DISCLAIMER**

This report contains information gathered from our suppliers and we do not make any representations about the accuracy of the data displayed nor do we accept responsibility for inaccurate data. WinDeed will not be liable for any damage caused by reliance on this report. This report is subject to the terms and conditions of the [WinDeed End User Licence Agreement \(EULA\)](#).





**Appendix 9C**  
**Schematic Diagrams**



**POLE INFORMATION:**

STRUCTURE CODE:	D-DT-7612/261AD-P
PHASE CONDUCTOR:	SINGLE TERN
SHIELD WIRE:	2x16kA OPGW
DEVIATION ANGLE:	0 DEGREES
DESIGN WIND SPAN:	190 m
UPLIFT:	0 m
DESIGN WEIGHT SPAN:	340 m
DESIGN ELECTRICAL SPAN:	330 m
TOTAL LENGTH:	20 m-24 m
SIDES:	12
WIND LOAD ON WIRES:	993-1070 Pa
WIND LOAD ON POLE:	800 Pa
MATERIAL:	S355JR

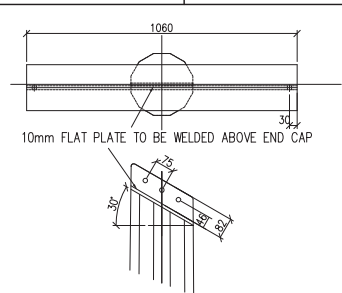
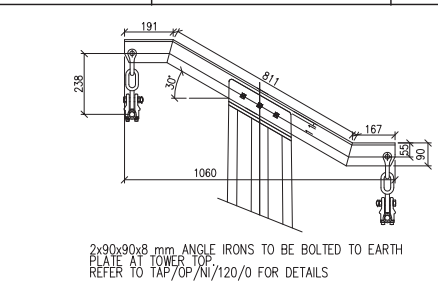

**POLE DESIGN SPECIFICATION:**

THE DESIGN OF THESE STRUCTURES IS GENERALLY IN ACCORDANCE WITH ASCE/SEI 48-11, DESIGN OF STEEL TRANSMISSION POLE STRUCTURES.

POLES TO BE FABRICATED AND ERECTED AS PER POLE FABRICATION SPECIFICATION DSP\_34-1683 (LATEST REVISION)

LOADING DETERMINED AS PER SANS 10280-1:2013 - DETAILED METHOD

THE ABOVE STATED WIND SPAN IS 0.9 OF DESIGN WIND SPAN FOR UNTESTED POLES

POLES TO BE FABRICATED AND ERECTED AS PER POLE FABRICATION SPECIFICATION DSP\_34-1683 (LATEST REVISION)

**261AD RECONFIGURED FOR LL SPACING & TWIN EARTHWIRES**

TIP LOAD = 37 KN

**FABRICATION/CONSTRUCTION INFORMATION:**

POLES WILL HAVE THE LOWEST NUMBER OF SLIP JOINTS IN CONFORMANCE WITH THE LIMITATION IMPOSED BY THE LENGTH OF THE GALVANISING BATH. SLIP JOINT LENGTH IS TO BE 1.5 TIMES THE LARGEST I.D. OF THE FEMALE SECTION.

JACKING TENSION: PLEASE REFER TO TOTAL JACKING LOAD MARKED J.T ON ADJACENT POLE OUTLINE. TO BE DIVIDED BY THE NUMBER OF LUGS AT THE SLIP JOINTS. JACKING LUGS FITTED ON THE POLE FACE AS PER DRAWING 0.69/02/JL (LATEST REVISION) OR AS DETAILED BY FABRICATOR.

FULL PENETRATION WELDS ARE TO BE USED ON: ALL SECTIONS JOINED BY THE CIRCUMFERENTIAL WELDS. ALL LONGITUDINAL WELDS WITHIN 75 mm OF CIRCUMFERENTIAL WELDS OR IN THE FEMALE SECTION OF A SLIP JOINT.

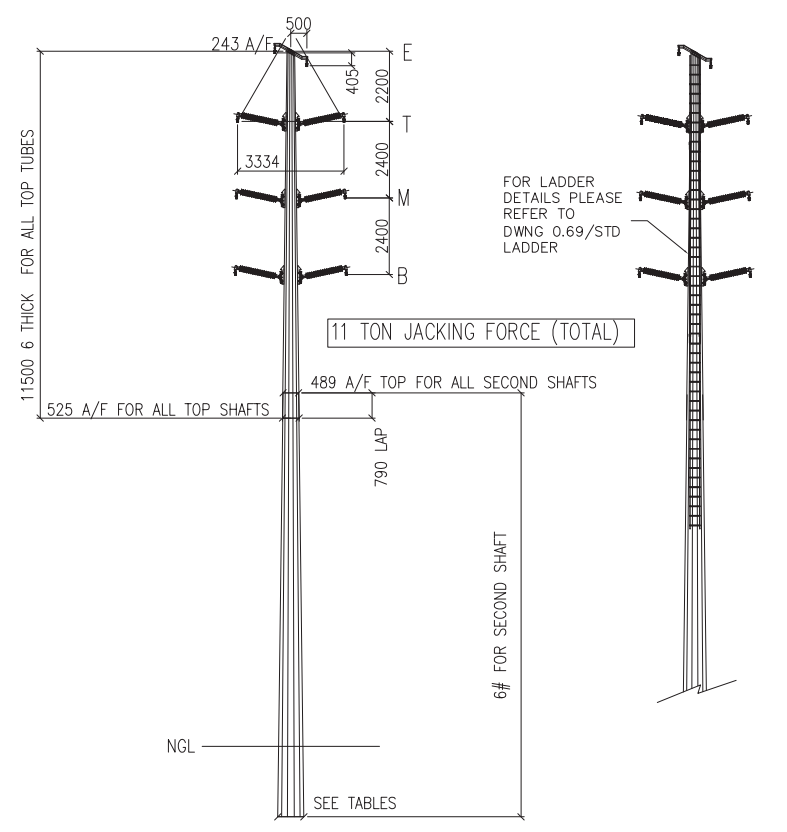

**ACCESS LADDERS ARE REQUIRED ON ALL STRUCTURES FROM APPROXIMATELY 6 m ABOVE GROUND LEVEL.**

**PROTRUDING EDGES OF THE POLE TIP CAP PLATE TO BE GROUND OFF. ALL SHARP CORNERS TO BE ROUNDED TO MIN 5 mm RADIUS.**

OPGW DOWNLEAD LUGS TO BE FITTED WHERE REQUIRED IN ACCORDANCE WITH 0.69/00/OPGW/POLC.

STRUCTURE TYPE AND NUMBER MUST BE CLEARLY SHOWN ON EACH POLE SECTION. IT IS PREFERABLE WHEREVER POSSIBLE TO WELD THIS INFORMATION TO THE SIDE/ INSIDE OF THE STRUCTURE FOR EACH SECTION AS WELL AS ON THE TEMPLATE, EG. "DESIGNATION"/1 (FIRST SECTION), DESIGNATION.CAH/2 (SECOND SECTION) ETC. AND DESIGNATION.CAH ON THE TEMPLATES.

FABRICATOR TO SPECIFY VENT HOLES FOR GALVANIZING.

WELDING TO BE MIN 6 mm CONTINUOUS SEAL TO SANS 10162 SECTION 11. HOT DIP GALVANISING TO SANS 121. STRESS RELIEVING TO BE APPLIED IN ACCORDANCE WITH SANS 121. TOLERANCES: ON DIMENSIONS: 2 mm ON DRILLING CENTRES: 2 mm

SEE DSP 34-1683 FOR OTHER TOLERANCES.

**PROJECT SPECIFIC: NOTES**

- PHASE SPACING IS MODIFIED FOR LIVE LINE FRIENDLY REQUIREMENTS.
- DRAWING DESIGN REF. (D-DT 7612).
- FOR SOIL TYPE T1-T4 POLE SHAFT DIMENSIONS ARE AS PER ORIGINAL DESIGN AND FABRICATION DETAIL.

**TABLE 1: PLANTED POLE FOR SOIL TYPE T1-T4**

POLE LENGTH (m)	DESIGN REQUIREMENTS			CAH (m AGL) *				NORMAL SHAFT DIMENSIONS		FINISHED POLE WEIGHT (kg)
	TIP LOAD (kN)	PLANTING DEPTH (m)	OTM (kN.m)	E	T	M	B	2nd SHAFT LENGTH (m)	A/F BOTTOM (m)	
20.0	37	2.6	644	17.4	15.2	12.8	10.4	9.29	0.717	1857
21.0	37	2.7	677	18.3	16.1	13.7	11.3	10.29	0.742	1988
22.0	37	2.8	710	19.2	17.0	14.6	12.2	11.29	0.766	2122
23.0	37	2.9	744	20.1	17.9	15.5	13.1	12.29	0.791	2260
24.0	37	3.0	777	21	18.8	16.4	14.0	13.29	0.815	2402

\* SEE NOTE 1



THIS DRAWING AND ANY INFORMATION OR DESCRIPTIVE MATTER SET OUT HEREON ARE THE CONFIDENTIAL AND COPYRIGHT PROPERTY OF TAP AND MUST NOT BE DISCLOSED, LOANED, COPIED OR USED FOR MANUFACTURING, TENDERING OR FOR ANY OTHER PURPOSE WITHOUT WRITTEN PERMISSION © 2015

5					
4					
3					
2					
1					
0	MZ:H	T:L	08/09/2015	261AD RECONFIGURED FOR LL SPACING AND HR & SR FOUNDATIONS.	
REV	DRAWN BY:	CHKD	DATE:	REVISION DESCRIPTION:	
				TITLE: DISTRIBUTION TECHNOLOGY RETICULATION/SUB-TRANSMISSION LINE	
				88/132kV S/C INTERMEDIATE STRUCTURE	
				D-DT-7612/261AD - PLANTED	
				T/261AD - P	
				SHEET 1	OF 1
				REV 0	



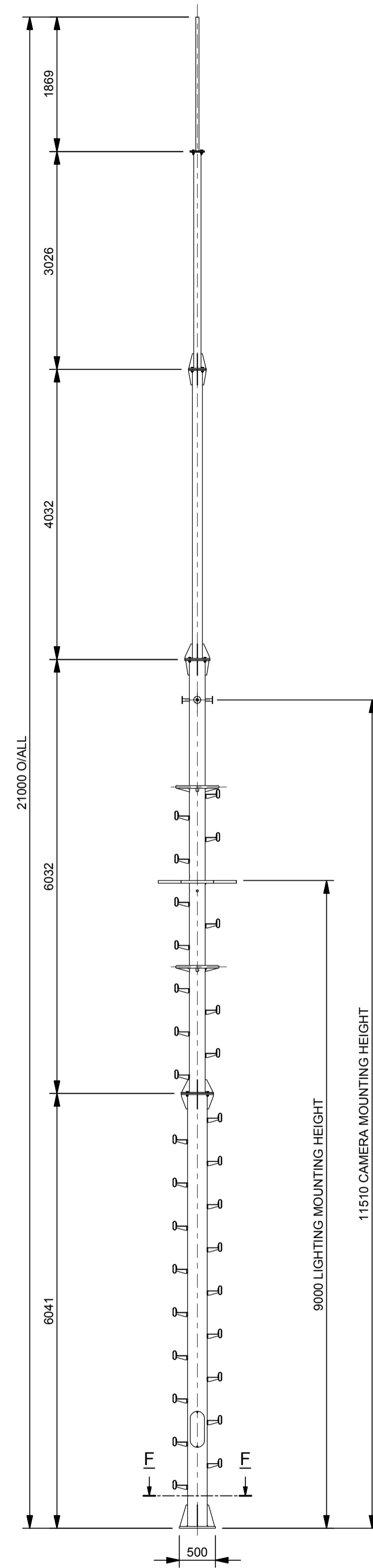

FRONT VIEW  
21m TUBULAR LIGHTNING / LIGHTING MAST SUPPORT (MK 'LMS-007')  
(1 : 50)

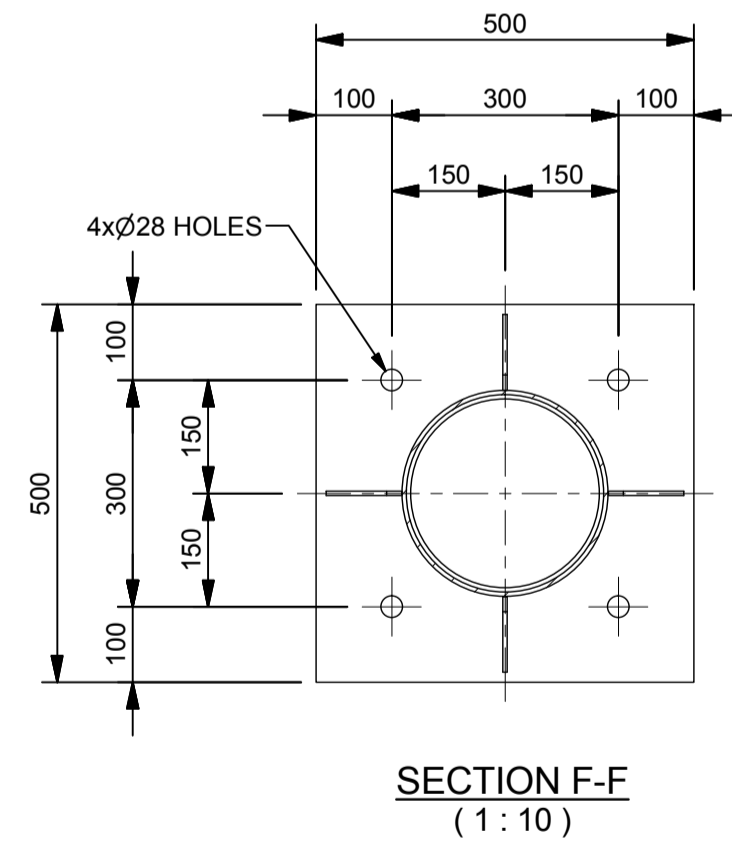

SECTION F-F  
(1 : 10)

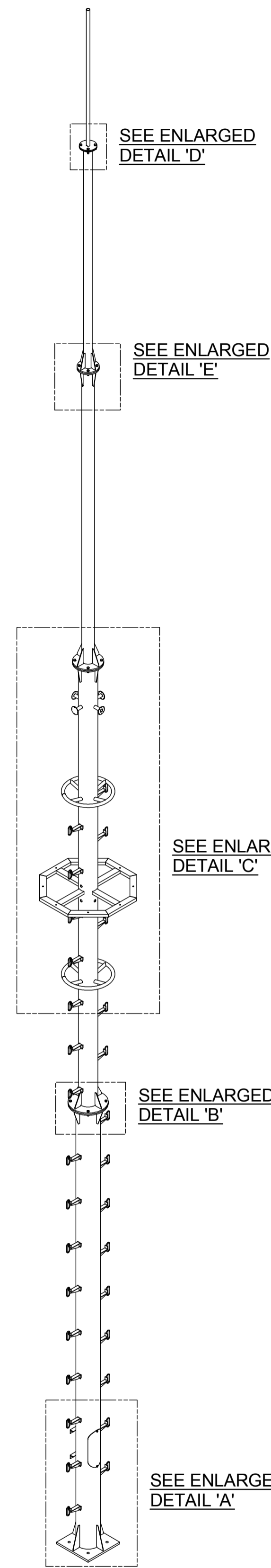

ISOMETRIC VIEW

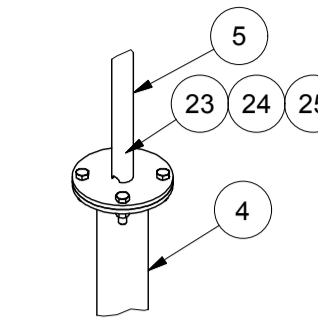

DETAIL D  
(1 : 15)

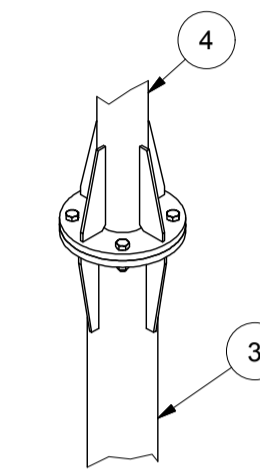

DETAIL E  
(1 : 15)

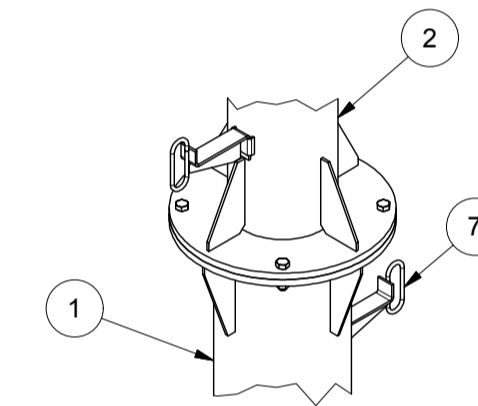

DETAIL B  
(1 : 15)

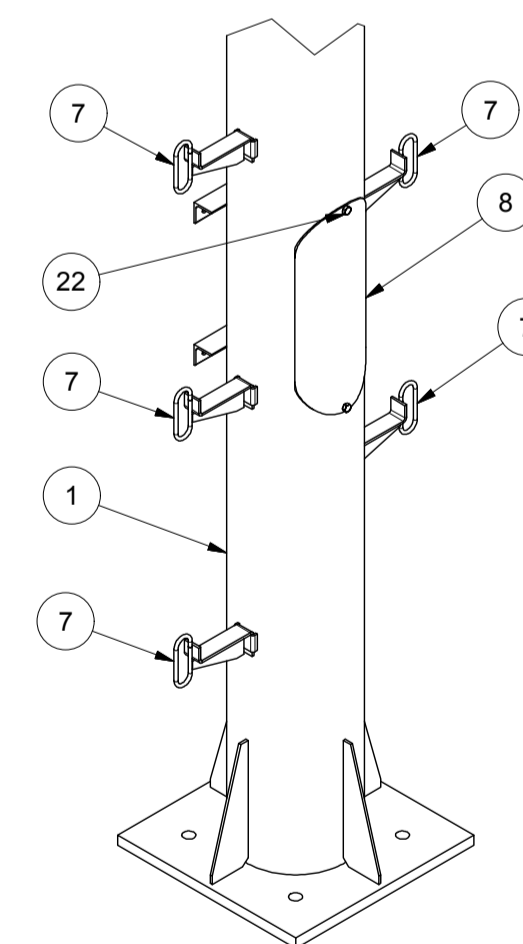

DETAIL A  
(1 : 15)

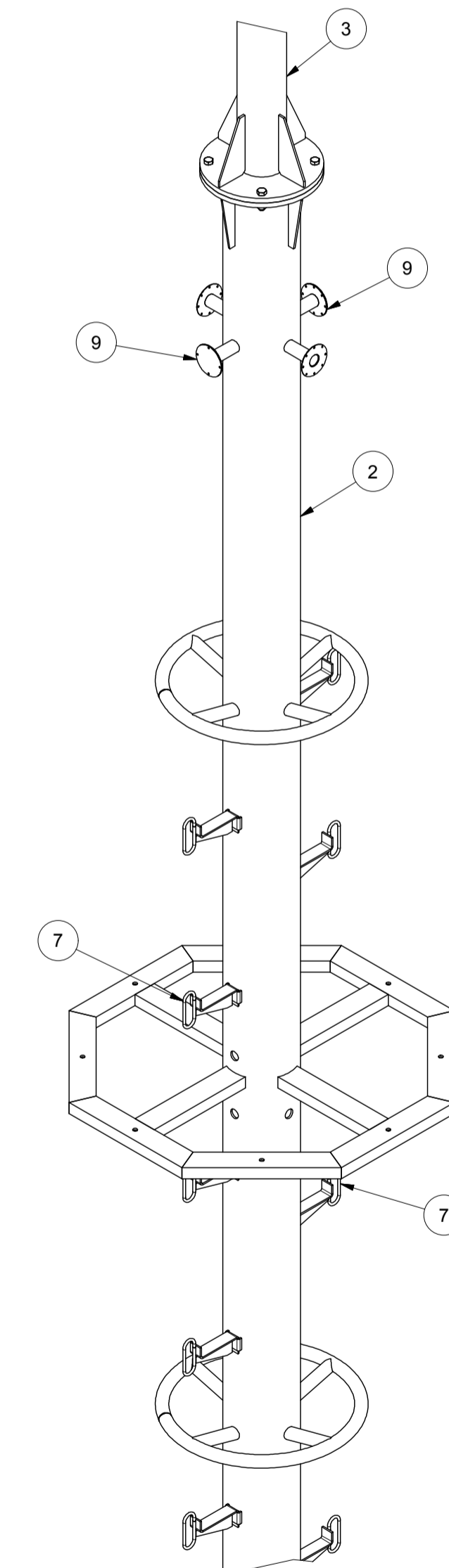

DETAIL C  
(1 : 15)

PARTS LIST				
ITEM	QTY	PART NUMBER	DESCRIPTION	MASS
1	1	LMS-007-01	6m TUBULAR ASSEMBLY 01	301,7 kg
2	1	LMS-007-02	6m TUBULAR ASSEMBLY 02	265,7 kg
3	1	LMS-007-03	4m TUBULAR ASSEMBLY 03	86,5 kg
4	1	LMS-007-04	3m TUBULAR ASSEMBLY 04	37,5 kg
5	1	LMS-007-05	3m TUBULAR ASSEMBLY 05	8,7 kg
7	30	LMS-007-06	STEP LUG ASSEMBLY	22,7 kg
8	1	LMS-007-07	220 mm x 3 mm THK x 500 mm LG PLT	2,4 kg
9	2	LMS-007-08	Ø100 mm x 2 mm THK COVER PLT	0,2 kg
	1		TOTAL STEEL MASS	725,4 kg

BOLT SCHEDULE - STRENGTH GRADE 4.8				
ITEM	QTY	DESCRIPTION	MASS	
22	2	M10x20 - SET SCREW - GALVANIZED	0,1 kg	
23	16	M16x55 - SET SCREW - GALVANIZED	2,0 kg	
24	16	M16 - FLAT WASHER - GALVANIZED	0,2 kg	
25	16	M16 - HEX NUT - GALVANIZED	0,5 kg	
	1	TOTAL BOLT MASS	2,8 kg	

- GENERAL STEEL NOTES:**
- ALL WORK TO BE IN ACCORDANCE WITH SANS 2001-CS 1 & SANS 1921-3, EXCEPT WHERE NOTED OTHERWISE ON THE DRAWING (OR PROJECT SPECIFICATION).
  - ALL HOLES Ø18mm FOR M16 Gr 4.8 BOLTS U.O.N.
  - ALL STEEL GRADE TO BE S355JR.
  - ALL WELDING CONTINUOUS FILLET, CLEAN AND SEAL WELDED. ALL FINISHED WELDS TO BE VISUALLY INSPECTED BY A QUALIFIED WELDING SUPERVISOR.
  - ALL EXCESS WELD SPATTER, SLAG AND SHARP BURRS TO BE REMOVED PRIOR TO GALVANISING.
  - ALL FINISHED ITEMS TO BE HARD STAMPED WITH THE INDIVIDUAL PART NUMBER PRIOR TO GALVANISING. PART NUMBER TO BE CLEARLY VISIBLE AFTER GALVANISING.
  - ALL FINISHED STEELWORK TO BE HOT DIP GALVANISED TO ISO 1461.
  - ALL GRADE 4.8 BOLTS TO BE TORQUED TO THE FOLLOWING FIGURES UNLESS OTHERWISE SPECIFIED (M10 - 20Nm, M12 - 34Nm, M16 - 85Nm, M20 - 166Nm)
  - NOTE THAT QTY INDICATED ON EACH ITEM IS FOR ONE STRUCTURE ONLY

REV	DATE	DESCRIPTION	BY	CHKD	REFERENCE DRAWING No.	REFERENCE DRAWING DESCRIPTION
A	31/08/15	ISSUED FOR APPROVAL	T.P	R.B		

COPYRIGHT: THIS DRAWING IS THE PROPERTY OF CONSOLIDATED POWER PROJECTS (PTY) LTD. IS PRIVATE AND CONFIDENTIAL AND IS SUPPLIED ON THE EXPRESS UNDERSTANDING THAT IT IS NOT TO BE USED FOR ANY PURPOSE OR COPIED OR COMMUNICATED TO ANY PERSON WITHOUT THE WRITTEN PERMISSION OF THE PROPRIETORS.		<b>CONCO PROJECT APPROVAL</b> DRAWN: T. PETERSEN, 2015-08-31 D.O. CHECK: [ ] PROJ. ENG: [ ] B.U.M. / DIR: [ ]		<b>CONCO STANDARD</b> TITLE: GENERAL ARRANGEMENT OF 21m LIGHTNING / LIGHTING MAST WITH CAMERA MOUNTING POINTS (MK 'LMS-007')	
<b>PROFESSIONAL ENGINEER / TECHNOLOGIST APPROVAL</b> NAME: C. Sillman, Reg. No. 200470105, SIGNATURE: [ ], DATE: [ ]		<b>CONSOLIDATED POWER PROJECTS (PTY) LTD.</b> 37 RICHARDS DRIVE, HALFWAY HOUSE, 1685. TEL: ++2711 805 4281, FAX: ++2711 805 1132. PRIVATE BAG X42, HALFWAY HOUSE, 1685. E-Mail: conco@concogrp.com, Web: www.concogrp.com		CONTRACT: [ ] DRG. No. SGA-LMS-0000-21000-007, REV A	