

DOOR DESCRIPTION

DOOR SIZE: 813mm x 2,032mm x 44mm
 SOLID HARDWOOD MERANTI FRAMED, LEDGED, BRACED & BATTENED DOOR BY SPECIALISTS WITH 6mm MERANTI VENEER BACKING FITTED TO BACK OF DOOR RECESSED INTO FRAME.
 MERANTI WEATHER BAR AND NYLON BRUSH STRIP TO BOTTOM OF DOOR EXTERNALLY.

TO TIMBER:
 CAREFULLY CLEAN AND PREPARE ALL SURFACES, FINE SANDING AND ROUNDING OFF SHARP EDGES AS NECESSARY. REMOVE ALL PARTICLES AND WIPE THE SURFACE CLEAN OF DUST. 3 X COATS OF "KANSAI PLASCON" OR SIMILAR APPROVED WOODCARE EXTERIOR, PREMIUM QUALITY WATER-BASED COATING TO BE PROVIDED TO DOOR AS PER MANUFACTURER'S SPECIFICATIONS. LIGHT SAND PAPER BETWEEN COATS WITH 240 GRITS SANDPAPER AND ALLOW 24 HOURS FOR DRYING IN-BETWEEN EACH LAYER. COMPLETE APPLICATION TO "WOODCARE INSTRUCTIONS. COLOUR IMBUA TO BE APPROVED BY ARCHITECT.
 NB: REMOVE ANY DUST BEFORE RE-COATING.

IRONMONGERY

LOCKSET
 UNION OR SIMILAR APPROVED 4 LEVER LOCKSET - SC, SATIN CHROME FINISHED
 PRODUCT CODE CZ68224615C
 HINGES EXCEPT FOR SHOWER DOORS.

UNION OR SIMILAR APPROVED JH-BB-STD-2-SS, SS 2BB BUTT HINGE EN1935GRD13 (THREE OF) WITH A STAINLESS STEEL FINISH, STAINLESS STEEL SCREWS TO BE PROVIDED, EXCEPT FOR SHOWER DOORS.

DOOR STOP
 1 X DOOR STOP WITH SATIN FINISH PRODUCT CODE 8700155 PRODUCT CODE CZ8731CH

TO SHOWER DOOR IN BLOCK 1 ONLY - STAINLESS STEEL DOUBLE ACTION SPRING HINGE CAFE SELF CLOSING DOOR HINGE TO BLOCKS 5 AND 7, EXISTING FRAMES TO BE MAINTAINED AND EXISTING PAINT TO BE CAREFULLY STRIPPED OFF, NEW DOOR TO BE PROVIDED

FRAME

FRAME:
 1.2MM ELECTRO - GALVANISED STEEL DOOR FRAME, SAMPLE TO BE APPROVED BY ARCHITECT PRIOR TO INSTALLATION. FRAME TO SUIT WALL THICKNESS

BREAKDOWN OF TOTAL

NO. REQUIRED	LHS	RHS
BLOCK C	01	01
TOTAL	01	01

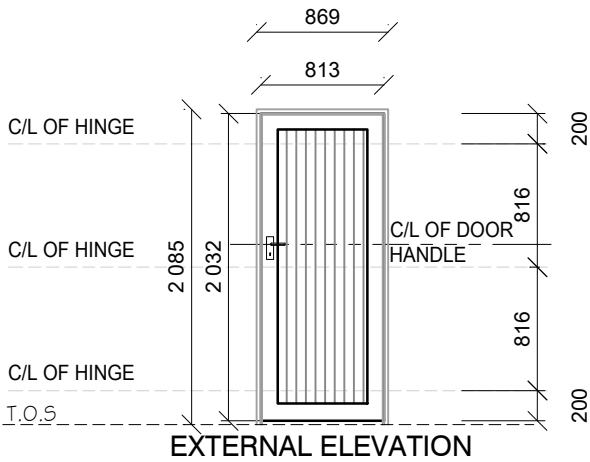

EXTERNAL ELEVATION

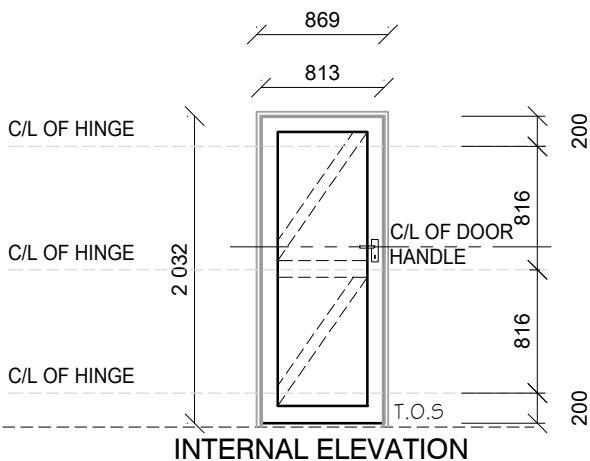

INTERNAL ELEVATION

DOOR TYPE
D 1

CLIENT:



DRAWING:

**BULWER P.S.
 DOOR SCHEDULE**

JOB No.
CDC 19/01

SHEET No.
DOOR 1

REV.
C



ARCHITECTURE & PROJECT MANAGEMENT

HEAD OFFICE: KWA-ZULU NATAL
 67 ALBERSVILLE ROAD
 PORT SHEPSTONE, 4240
 TEL : 039 032 0003
 FAX : 039 682 7510
 MOBILE : 082 554 3427

BRANCH: EASTERN CAPE
 OFFICE No. 2, FYNN HOUSE
 STREET No. 6
 BIZANA, 4800
 TEL: 039 251 0476
 FAX: 086 577 7713

✉ P. O. BOX 455, PORT SHEPSTONE, 4240
 e-mail: vhb@vhbassociates.co.za

DOOR DESCRIPTION

SOLID HARDWOOD HORIZONTAL ROUTED MERANTI DOOR BY SPECIALISTS. MERANTI WEATHER BAR AND MERANTI WEATHER STRIP TO BOTTOM OF DOOR TO ALL EXTERNAL DOORS.
DOOR SIZE: 1.000mm x 2,032mm x 44mm

TO TIMBER:

CAREFULLY CLEAN AND PREPARE ALL SURFACES, FINE SANDING AND ROUNDING OFF SHARP EDGES AS NECESSARY. REMOVE ALL PARTICLES AND WIPE THE SURFACE CLEAN OF DUST. 3 X COATS OF "KANSAI PLASCON" OR SIMILAR APPROVED WOODCARE EXTERIOR, PREMIUM QUALITY WATER-BASED COATING TO BE PROVIDED TO DOOR AS PER MANUFACTURER'S SPECIFICATIONS. LIGHT SAND PAPER BETWEEN COATS WITH 240 GRITS SANDPAPER AND ALLOW 24 HOURS FOR DRYING IN-BETWEEN EACH LAYER. COMPLETE APPLICATION TO "WOODCARE INSTRUCTIONS. COLOUR IMBUIA TO BE APPROVED BY ARCHITECT.

NB: REMOVE ANY DUST BEFORE RE-COATING.

IRONMONGERY

HINGES

UNION OR SIMILAR APPROVED JH-BB-STD-2-55, 55 2BB BUTT HINGE EN 1935GRD 13 (THREE OF) WITH A STAINLESS STEEL FINISH, STAINLESS STEEL SCREWS TO BE PROVIDED DOOR CLOSER

HOLD OPEN CLOSER DC300HO EN-3-G

HANDLE

2 x UNION STAINLESS STEEL 300mm PULL HANDLE FLANGE FIXED 22mm DIAMETER PRODUCT CODE PHD-CF-300-2255

ROLLER CATCH

1 x ADJUSTABLE ROLLER CATCH PRODUCT CODE ARC 118255

INDICATOR BOLT

1 x UNION INDICATOR FACILITY BOLT PRODUCT CODE 37651A5

COAT HOOK & DOOR STOP

1 x UNION HAT AND COAT HOOK WITH BUFFER PRODUCT CODE AND 1 x UNION DOOR STOP WITH SATIN FINISH PRODUCT CODE 8700155 55802555

KICKPLATE & DOOR SIGN

1 x PARAPLEGIC TOILET SIGN PRODUCT AL506G-06A5E14
2 X 700 x 800 x 2mm - AL5089-700W

FRAME

FRAME:

1.2MM ELECTRO - GALVANISED STEEL DOOR FRAME, SAMPLE TO BE APPROVED BY ARCHITECT PRIOR TO INSTALLATION. FRAME TO SUIT WALL THICKNESS

BREAKDOWN OF TOTAL

NO. REQUIRED	LHS	RHS
BLOCK C	01	01
TOTAL	01	01

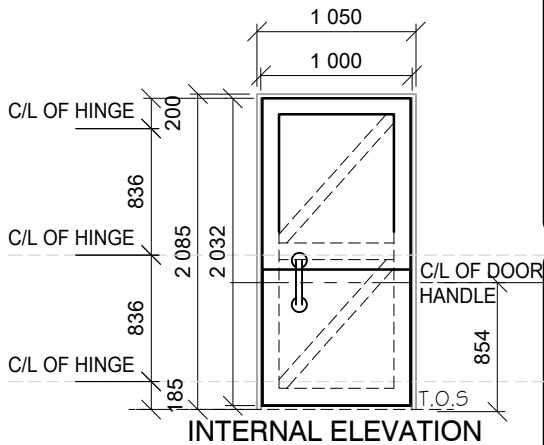
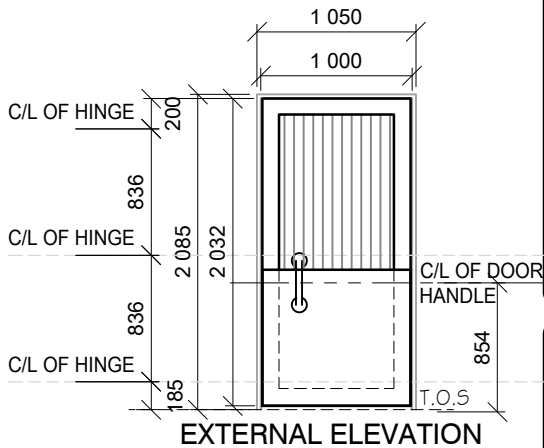

DOOR TYPE
D 2

CLIENT:



DRAWING:

BULWER P.S.
DOOR SCHEDULE

JOB No.

CDC 19/01

SHEET No.

DOOR 2

REV.

C



ARCHITECTURE & PROJECT MANAGEMENT

HEAD OFFICE: KWA-ZULU NATAL

67 ALBERSVILLE ROAD

PORT SHEPSTONE, 4240

TEL : 039 032 0003

FAX : 039 682 7510

MOBILE : 082 554 3427

BRANCH: EASTERN CAPE

OFFICE No. 2, FYNN HOUSE

STREET No. 6

BIZANA, 4800

TEL: 039 251 0476

FAX: 086 577 7713

✉ P. O. BOX 455, PORT SHEPSTONE, 4240
e-mail: vhb@vhbassociates.co.za

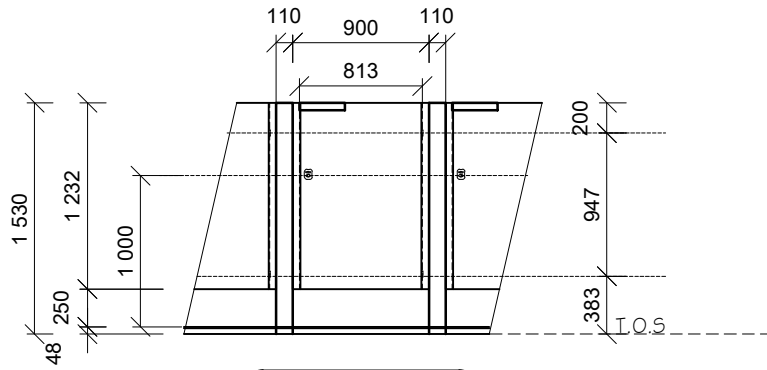

DOOR TYPE
D 3

DOOR DESCRIPTION
 813 x 1,232mm SELECTED MERANTI DOOR WITH: 44 x 114mm STYLES AND TOP RAIL 44 x 228mm BOTTOM RAIL AND 22mm T&G SLATS.
 CAREFULLY CLEAN AND PREPARE ALL SURFACES, FINE SANDING AND ROUNDING OFF SHARP EDGES AS NECESSARY. REMOVE ALL PARTICLES AND WIPE THE SURFACE CLEAN OF DUST. 3 X COATS OF "KANSAI PLASCON" OR SIMILAR APPROVED WOODCARE EXTERIOR, PREMIUM QUALITY WATER-BASED COATING TO BE PROVIDED TO DOOR AS PER MANUFACTURER'S SPECIFICATIONS. LIGHT SAND PAPER BETWEEN COATS WITH 240 GRITS SANDPAPER AND ALLOW 24 HOURS FOR DRYING IN-BETWEEN EACH LAYER. COMPLETE APPLICATION TO "WOODCARE INSTRUCTIONS. COLOUR IMBUIA TO BE APPROVED BY ARCHITECT.
 NB: REMOVE ANY DUST BEFORE RE-COATING.

IRONMONGERY
 1 x H/D ADJUSTABLE ROLLER CATCH. 1 x FORMED 300 x 150mm STAINLESS STEEL PLATE - FORMED OVER THE TOP OF THE DOOR - BENT TWICE EXTENDING 50mm DOWN TOP EDGE OF DOOR ON BOTH SIDES. 2 - 75 x 41mm SC ON BRASS BUTT HINGES

FRAME
 HARDWOOD SINGLE DOOR FRAME WITH 90 x 50mm SECTIONS & NO SILL. BACK OF FRAME TO RECEIVE 2 x COATS WATERPROOFING PRIMER. PREPARE AND PAINT ONE UNIVERSAL UNDERCOAT AND TWO COATS GLOSS ENAMEL PAINT ON GENERAL SURFACES OF DOOR, INCLUDING TOP AND BOTTOM SURFACES AND REVEALS. COLOUR TO ARCHITECTS SURFACES AND REVEALS. COLOUR TO ARCHITECTS

BREAKDOWN OF TOTAL		
NO. REQUIRED	LHS	RHS
BLOCK A	06	---
TOTAL	06	---

CLIENT:



DRAWING:
BULWER P.S.
DOOR SCHEDULE

JOB No. CDC 19/01	SHEET No. DOOR 3	REV. C
-----------------------------	----------------------------	------------------



ARCHITECTURE & PROJECT MANAGEMENT
HEAD OFFICE: KWA-ZULU NATAL **BRANCH: EASTERN CAPE**
 67 ALBERSVILLE ROAD OFFICE No. 2, FYNN HOUSE
 PORT SHEPSTONE, 4240 STREET No. 6
 TEL : 039 032 0003 BIZANA, 4800
 FAX : 039 682 7510 TEL: 039 251 0476
 MOBILE : 082 554 3427 FAX: 086 577 7713

✉ P. O. BOX 455, PORT SHEPSTONE, 4240
 e-mail: vhb@vhbassociates.co.za

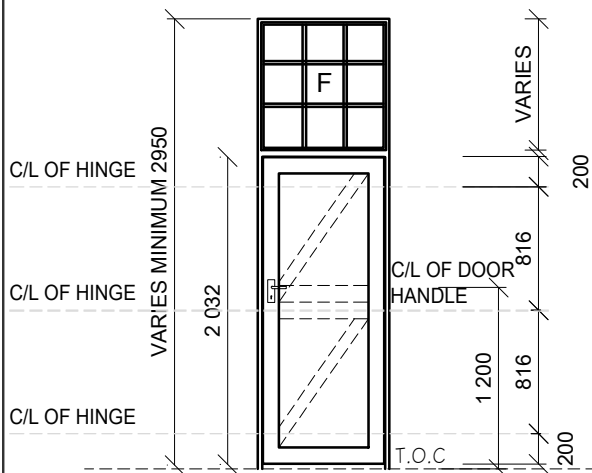
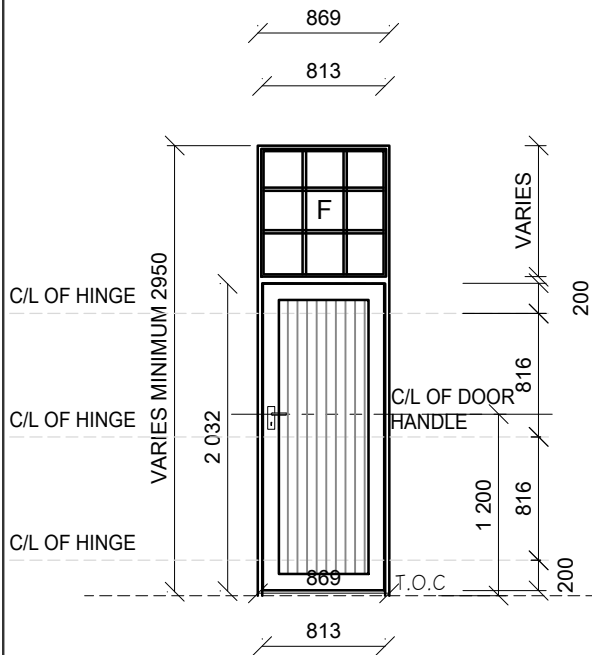

DOOR TYPE
D 4

DOOR DESCRIPTION

SOLID HARDWOOD MERANTI FRAMED, LEDGED, BRACED & BATTENED DOOR BY SPECIALISTS WITH 6mm MERANTI VENEER BACKING FITTED TO BACK OF DOOR RECESSED INTO FRAME.
MERANTI WEATHER BAR AND NYLON BRUSH STRIP TO BOTTOM OF DOOR EXTERNALLY.
DOOR SIZE: 813-952mm x 2,032mm x 44mm - TO FIT 900-1035mm OPENINGS ALL OPENINGS TO EXISTING DOOR TO BE MEASURED PRIOR TO MANUFACTURING

TO TIMBER:
CAREFULLY CLEAN AND PREPARE ALL SURFACES, FINE SANDING AND ROUNDING OFF SHARP EDGES AS NECESSARY. REMOVE ALL PARTICLES AND WIPE THE SURFACE CLEAN OF DUST. 3 X COATS OF "KANSAI PLASCON" OR SIMILAR APPROVED WOODCARE EXTERIOR, PREMIUM QUALITY WATER-BASED COATING TO BE PROVIDED TO DOOR AS PER MANUFACTURER'S SPECIFICATIONS. LIGHT SAND PAPER BETWEEN COATS WITH 240 GRITS SANDPAPER AND ALLOW 24 HOURS FOR DRYING IN-BETWEEN EACH LAYER. COMPLETE APPLICATION TO "WOODCARE INSTRUCTIONS. COLOUR IMBUIA TO BE APPROVED BY ARCHITECT.
NB: REMOVE ANY DUST BEFORE RE-COATING.

FANLIGHT
4mm CLEAR FLOAT GLAZING TO COMPLY WITH PART N SANS 10400 TO FORM FANLIGHT

IRONMONGERY

LOCKSET
UNION OR SIMILAR APPROVED 4 LEVER LOCKSET - SC, SATIN CHROME FINISHED
PRODUCT CODE C268224615C
HINGES EXCEPT FOR SHOWER DOORS.

UNION OR SIMILAR APPROVED JH-BB-STD-2-55, 55 2BB BUTT HINGE EN1935GRD13 (THREE OF) WITH A STAINLESS STEEL FINISH, STAINLESS STEEL SCREWS TO BE PROVIDED, EXCEPT FOR SHOWER DOORS.

DOOR STOP
1" X DOOR STOP WITH SATIN FINISH PRODUCT CODE 8700155 PRODUCT CODE C28731CH

TO SHOWER DOOR IN BLOCK 1 ONLY - STAINLESS STEEL DOUBLE ACTION SPRING HINGE CAFE SELF CLOSING DOOR HINGE TO BLOCKS 5 AND 7, EXISTING FRAMES TO BE MAINTAINED AND EXISTING PAINT TO BE CAREFULLY STRIPPED OFF, NEW DOOR TO BE PROVIDED

FRAME

SELECTED 55 x 90 MERANTI DOOR FRAME.

BREAKDOWN OF TOTAL

NO. REQUIRED	LHS	RHS
BLOCK B	03	05
BLOCK D	03	03
TOTAL	06	08

CLIENT:



DRAWING:

**BULWER P.S.
DOOR SCHEDULE**

JOB No.
CDC 19/01

SHEET No.
DOOR 4

REV.
C



ARCHITECTURE & PROJECT MANAGEMENT

HEAD OFFICE: KWA-ZULU NATAL

67 ALBERSVILLE ROAD

PORT SHEPSTONE, 4240

TEL : 039 032 0003

FAX : 039 682 7510

MOBILE : 082 554 3427

BRANCH: EASTERN CAPE

OFFICE No. 2, FYNN HOUSE

STREET No. 6

BIZANA, 4800

TEL: 039 251 0476

FAX: 086 577 7713

✉ P. O. BOX 455, PORT SHEPSTONE, 4240
e-mail: vhb@vhbassociates.co.za

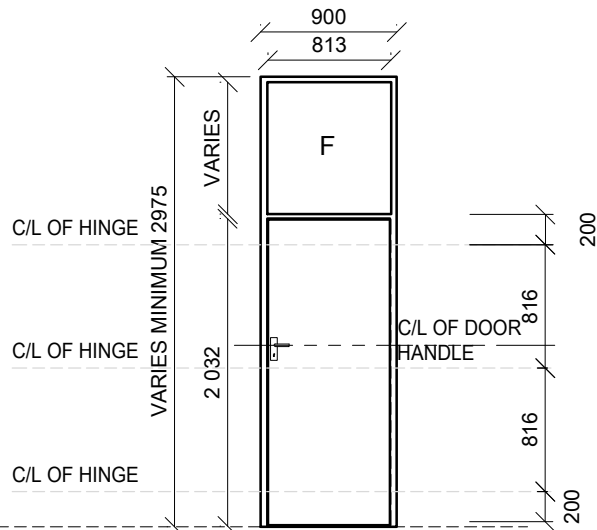

DOOR TYPE
D 5

DOOR DESCRIPTION

SEMI-SOLID FLUSH DOOR WITH 3.2mm TEMPERED HARDBOARD FACINGS AND 4 HARDWOOD EDGE STRIPS. DOOR MANUFACTURED ACCORDING TO SANS 545

DOOR SIZE: 813mm x 2,032mm x 44mm TO FIT 900mm WIDE OPENINGS ALL OPENINGS TO EXISTING DOOR TO BE MEASURED PRIOR TO MANUFACTURING, FRAME TO BE MANUFACTURED TO SUIT EITHER 110mm OR 230mm WALL AS PER FLOOR PLA

TO TIMBER:

CAREFULLY CLEAN AND PREPARE ALL SURFACES, FINE SANDING AND ROUNDING OFF SHARP EDGES AS NECESSARY. REMOVE ALL PARTICLES AND WIPE THE SURFACE CLEAN OF DUST. 3 X COATS OF "KANSAI PLASCON" OR SIMILAR APPROVED WOODCARE EXTERIOR, PREMIUM QUALITY WATER-BASED COATING TO BE PROVIDED TO DOOR AS PER MANUFACTURER'S SPECIFICATIONS. LIGHT SAND PAPER BETWEEN COATS WITH 240 GRITS SANDPAPER AND ALLOW 24 HOURS FOR DRYING IN-BETWEEN EACH LAYER. COMPLETE APPLICATION TO "WOODCARE INSTRUCTIONS. COLOUR IMBUA TO BE APPROVED BY ARCHITECT.

NB: REMOVE ANY DUST BEFORE RE-COATING.

FANLIGHT

4mm CLEAR FLOAT GLAZING TO COMPLY WITH PART N SANS 10400 TO FORM FANLIGHT

IRONMONGERY

LOCKSET

UNION OR SIMILAR APPROVED 4 LEVER LOCKSET - SC, SATIN CHROME FINISHED PRODUCT CODE CZ6822461SC

HINGES EXCEPT FOR SHOWER DOORS.

UNION OR SIMILAR APPROVED JH-BB-STD-2-55, 55 2BB BUTT HINGE EN1935GRD13 (THREE OF) WITH A STAINLESS STEEL FINISH, STAINLESS STEEL SCREWS TO BE PROVIDED, EXCEPT FOR SHOWER DOORS.

DOOR STOP

1 X DOOR STOP WITH SATIN FINISH PRODUCT CODE 8700155 PRODUCT CODE CZ8731CH

TO SHOWER DOOR IN BLOCK 1 ONLY - STAINLESS STEEL DOUBLE ACTION SPRING HINGE CAFE SELF CLOSING DOOR HINGE TO BLOCKS 5 AND 7, EXISTING FRAMES TO BE MAINTAINED AND EXISTING PAINT TO BE CAREFULLY STRIPPED OFF, NEW DOOR TO BE PROVIDED

FRAME

SELECTED 55 x 90 MERANTI DOOR FRAME AND 68mm BULLNOSE ARCHITRAVES

BREAKDOWN OF TOTAL

NO. REQUIRED	LHS	RHS
BLOCK B	02	03
BLOCK D	07	19
TOTAL	09	22

CLIENT:



DRAWING:

BULWER P.S.
DOOR SCHEDULE

JOB No.
CDC 19/01

SHEET No.
DOOR 5

REV.
C



ARCHITECTURE & PROJECT MANAGEMENT

HEAD OFFICE: KWA-ZULU NATAL

67 ALBERSVILLE ROAD

PORT SHEPSTONE, 4240

TEL : 039 032 0003

FAX : 039 682 7510

MOBILE : 082 554 3427

BRANCH: EASTERN CAPE

OFFICE No. 2, FYNN HOUSE

STREET No. 6

BIZANA, 4800

TEL: 039 251 0476

FAX: 086 577 7713

✉ P. O. BOX 455, PORT SHEPSTONE, 4240
e-mail: vhb@vhbassociates.co.za

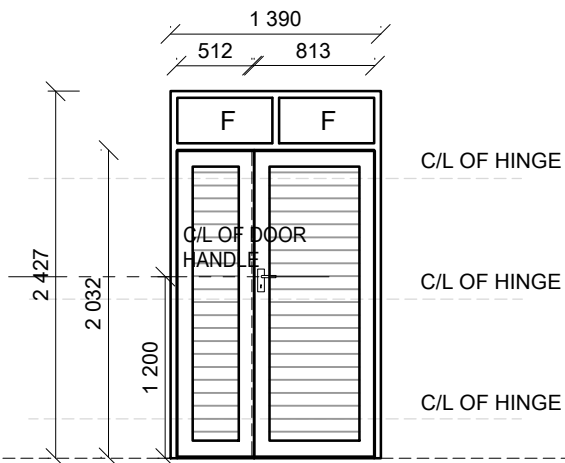

DOOR DESCRIPTION

DOOR SIZE: 1390mm (OPENING SIZE) x 2,032mm x 44mm

SOLID HARDWOOD MERANTI FRAMED, LEDGED, BRACED & BATTENED DOOR BY SPECIALISTS WITH REBATED MEETING STYLES AND 6mm MERANTI VENEER BACKING FITTED TO BACK OF DOOR RECESSED INTO FRAME.

TO TIMBER:
CAREFULLY CLEAN AND PREPARE ALL SURFACES, FINE SANDING AND ROUNDING OFF SHARP EDGES AS NECESSARY. REMOVE ALL PARTICLES AND WIPE THE SURFACE CLEAN OF DUST. 3 X COATS OF "KANSAI PLASCON" OR SIMILAR APPROVED WOODCARE EXTERIOR, PREMIUM QUALITY WATER-BASED COATING TO BE PROVIDED TO DOOR AS PER MANUFACTURER'S SPECIFICATIONS. LIGHT SAND PAPER BETWEEN COATS WITH 240 GRITS SANDPAPER AND ALLOW 24 HOURS FOR DRYING IN-BETWEEN EACH LAYER. COMPLETE APPLICATION TO "WOODCARE INSTRUCTIONS. COLOUR IMBUIA TO BE APPROVED BY ARCHITECT. NB: REMOVE ANY DUST BEFORE RE-COATING.

FANLIGHT
4mm CLEAR FLOAT GLAZING TO COMPLY WITH PART N SANS 10400 TO FORM FANLIGHT

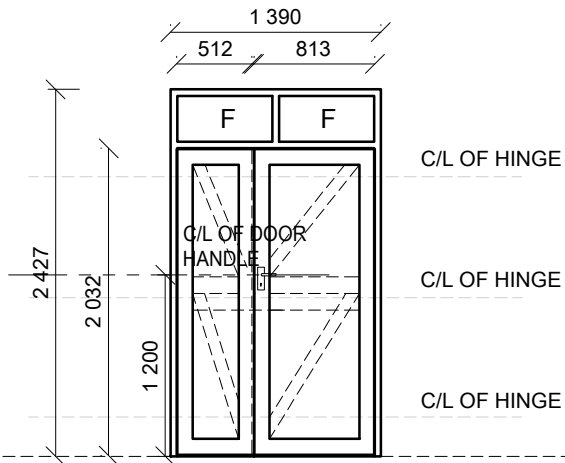

IRONMONGERY

FLUSH BOLT
UNION OR EQUAL APPROVED AL8208-150AS ART 208C91 U/FLUSH BOLT 150MM WITH ANODISED FINISH
DUST PROOF STRIKE
UNION OR EQUAL APPROVED 88525C DUST PROOF STRIKE
LOCKSET
UNION OR SIMILAR APPROVED 4 LEVER LOCKSET - 5C, SATIN CHROME FINISHED PRODUCT CODE CZ682246 I SC, REBATE CONVERSION SET TO BE PROVIDED.
HINGES AND DOOR STOP
UNION OR EQUAL APPROVED PARLIAMENT HINGES (THREE OF). STAINLESS STEEL SCREWS TO BE PROVIDED
2 X DOOR STOP WITH SATIN FINISH PRODUCT CODE 8700155 PRODUCT CODE CZ8731 CH

FRAME

SELECTED 55 x 90 MERANTI DOOR FRAME.

DOOR TYPE
D 6

BREAKDOWN OF TOTAL

NO. REQUIRED	
BLOCK A&B	01
BLOCK D	04
BLOCK E	01
TOTAL	06

CLIENT:



DRAWING:

**BULWER P.S.
DOOR SCHEDULE**

JOB No.
CDC 19/01

SHEET No.
DOOR 6

REV.
C



ARCHITECTURE & PROJECT MANAGEMENT

HEAD OFFICE: KWA-ZULU NATAL

67 ALBERSVILLE ROAD

PORT SHEPSTONE, 4240

TEL : 039 032 0003

FAX : 039 682 7510

MOBILE : 082 554 3427

BRANCH: EASTERN CAPE

OFFICE No. 2, FYNN HOUSE

STREET No. 6

BIZANA, 4800

TEL: 039 251 0476

FAX: 086 577 7713

✉ P. O. BOX 455, PORT SHEPSTONE, 4240
e-mail: vhb@vhbassociates.co.za

DOOR DESCRIPTION

DOOR SIZE: 813MM X 2,032MM X 44MM
 SOLID HARDWOOD MERANTI FRAMED, LEDGED, BRACED & BATTENED DOOR BY SPECIALISTS WITH 6mm MERANTI VENEER BACKING FITTED TO BACK OF DOOR RECESSED INTO FRAME.
 MERANTI WEATHER BAR AND NYLON BRUSH STRIP TO BOTTOM OF DOOR EXTERNALLY.

TO TIMBER:
 CAREFULLY CLEAN AND PREPARE ALL SURFACES, FINE SANDING AND ROUNDING OFF SHARP EDGES AS NECESSARY. REMOVE ALL PARTICLES AND WIPE THE SURFACE CLEAN OF DUST. 3 X COATS OF "KANSAI PLASCON" OR SIMILAR APPROVED WOODCARE EXTERIOR, PREMIUM QUALITY WATER-BASED COATING TO BE PROVIDED TO DOOR AS PER MANUFACTURER'S SPECIFICATIONS. LIGHT SAND PAPER BETWEEN COATS WITH 240 GRITS SANDPAPER AND ALLOW 24 HOURS FOR DRYING IN-BETWEEN EACH LAYER. COMPLETE APPLICATION TO "WOODCARE INSTRUCTIONS. COLOUR IMBUJA TO BE APPROVED BY ARCHITECT.
 NB: REMOVE ANY DUST BEFORE RE-COATING.

FANLIGHT
 4mm CLEAR FLOAT GLAZING TO COMPLY WITH PART N SANS 10400 TO FORM FANLIGHT

IRONMONGERY

LOCKSET
 UNION OR SIMILAR APPROVED 4 LEVER LOCKSET - SC, SATIN CHROME FINISHED PRODUCT CODE CZ68224615C
 HINGES EXCEPT FOR SHOWER DOORS.
 UNION OR SIMILAR APPROVED JH-BB-STD-2-SS, SS 2BB BUTT HINGE EN1935GRD13 (THREE OF) WITH A STAINLESS STEEL FINISH, STAINLESS STEEL SCREWS TO BE PROVIDED, EXCEPT FOR SHOWER DOORS.

DOOR STOP
 1 X DOOR STOP WITH SATIN FINISH PRODUCT CODE 8700155 PRODUCT CODE CZ8731CH

TO SHOWER DOOR IN BLOCK 1 ONLY - STAINLESS STEEL DOUBLE ACTION SPRING HINGE CAFE SELF CLOSING DOOR HINGE TO BLOCKS 5 AND 7, EXISTING FRAMES TO BE MAINTAINED AND EXISTING PAINT TO BE CAREFULLY STRIPPED OFF, NEW DOOR TO BE PROVIDED

FRAME

FRAME:
 1.2MM ELECTRO - GALVANISED STEEL DOOR FRAME, SAMPLE TO BE APPROVED BY ARCHITECT PRIOR TO INSTALLATION. FRAME TO SUIT WALL THICKNESS

BREAKDOWN OF TOTAL

NO. REQUIRED	LHS	RHS
BLOCK C	06	09
BLOCK H	01	---
TOTAL	07	09

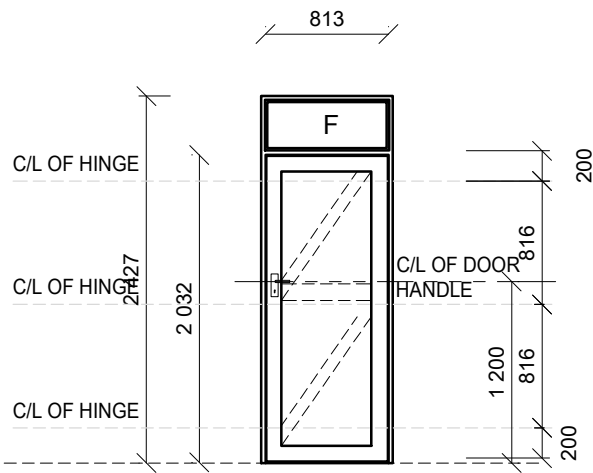
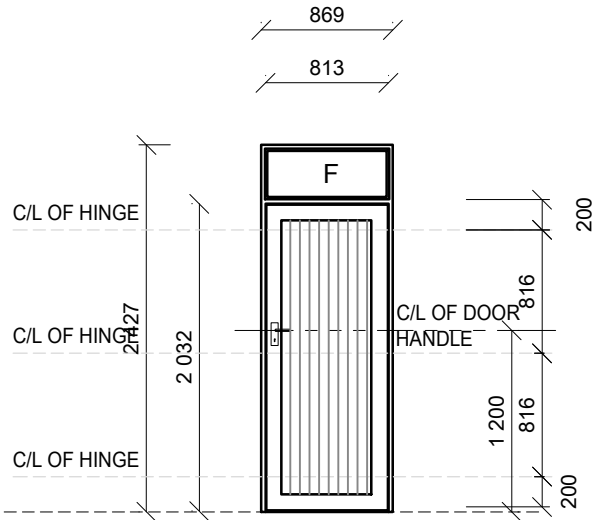

DOOR TYPE
D 7

CLIENT:



DRAWING:

BULWER P.S.
DOOR SCHEDULE

JOB No.
CDC 19/01

SHEET No.
DOOR 7

REV.
C



ARCHITECTURE & PROJECT MANAGEMENT

HEAD OFFICE: KWA-ZULU NATAL

BRANCH: EASTERN CAPE

67 ALBERSVILLE ROAD

OFFICE No. 2, FYNN HOUSE

PORT SHEPSTONE, 4240

STREET No. 6

TEL : 039 032 0003

BIZANA, 4800

FAX : 039 682 7510

TEL: 039 251 0476

MOBILE : 082 554 3427

FAX: 086 577 7713

✉ P. O. BOX 455, PORT SHEPSTONE, 4240
 e-mail: vhb@vhbassociates.co.za

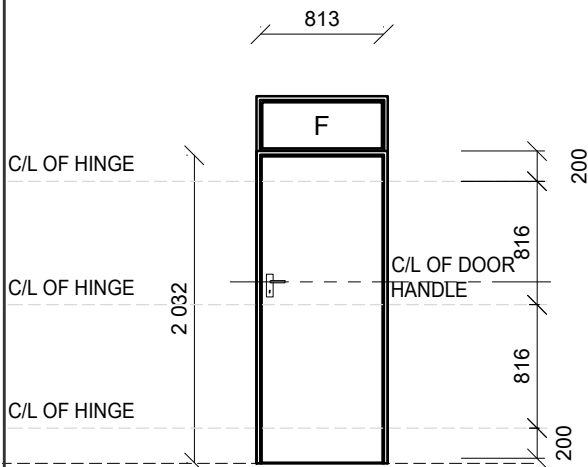

DOOR TYPE
D 8

DOOR DESCRIPTION

SEMI-SOLID FLUSH DOOR WITH 3.2mm TEMPERED HARDBOARD FACINGS AND 4 HARDWOOD EDGE STRIPS. DOOR MANUFACTURED ACCORDING TO SANS 545

DOOR SIZE: 813mm x 2,032mm x 44mm TO FIT 900mm WIDE OPENINGS ALL OPENINGS TO EXISTING DOOR TO BE MEASURED PRIOR TO MANUFACTURING, FRAME TO BE MANUFACTURED TO SUIT EITHER 110mm OR 230mm WALL AS PER FLOOR PLA

TO TIMBER:

CAREFULLY CLEAN AND PREPARE ALL SURFACES, FINE SANDING AND ROUNDING OFF SHARP EDGES AS NECESSARY. REMOVE ALL PARTICLES AND WIPE THE SURFACE CLEAN OF DUST. 3 X COATS OF "KANSAI PLASCON" OR SIMILAR APPROVED WOODCARE EXTERIOR, PREMIUM QUALITY WATER-BASED COATING TO BE PROVIDED TO DOOR AS PER MANUFACTURER'S SPECIFICATIONS. LIGHT SAND PAPER BETWEEN COATS WITH 240 GRITS SANDPAPER AND ALLOW 24 HOURS FOR DRYING IN-BETWEEN EACH LAYER. COMPLETE APPLICATION TO "WOODCARE INSTRUCTIONS. COLOUR IMBUIA TO BE APPROVED BY ARCHITECT.

NB: REMOVE ANY DUST BEFORE RE-COATING.

FANLIGHT

4mm CLEAR FLOAT GLAZING TO COMPLY WITH PART N SANS 10400 TO FORM FANLIGHT

IRONMONGERY

LOCKSET

UNION OR SIMILAR APPROVED 4 LEVER LOCKSET - SC, SATIN CHROME FINISHED PRODUCT CODE CZ68224615C

HINGES EXCEPT FOR SHOWER DOORS.

UNION OR SIMILAR APPROVED JH-BB-STD-2-SS, SS 2BB BUTT HINGE EN1935GRD13 (THREE OF) WITH A STAINLESS STEEL FINISH, STAINLESS STEEL SCREWS TO BE PROVIDED, EXCEPT FOR SHOWER DOORS.

DOOR STOP

1 X DOOR STOP WITH SATIN FINISH PRODUCT CODE 8700155 PRODUCT CODE CZ8731CH

TO SHOWER DOOR IN BLOCK 1 ONLY - STAINLESS STEEL DOUBLE ACTION SPRING HINGE CAPE SELF CLOSING DOOR HINGE TO BLOCKS 5 AND 7, EXISTING FRAMES TO BE MAINTAINED AND EXISTING PAINT TO BE CAREFULLY STRIPPED OFF, NEW DOOR TO BE PROVIDED

FRAME

FRAME:

1.2MM ELECTRO - GALVANISED STEEL DOOR FRAME, SAMPLE TO BE APPROVED BY ARCHITECT PRIOR TO INSTALLATION. FRAME TO SUIT WALL THICKNESS

BREAKDOWN OF TOTAL

NO. REQUIRED	LHS	RHS
BLOCK C	7	12
TOTAL	7	12

CLIENT:



DRAWING:

BULWER P.S.
DOOR SCHEDULE

JOB No.
CDC 19/01

SHEET No.
DOOR 8

REV.
C



ARCHITECTURE & PROJECT MANAGEMENT

HEAD OFFICE: KWA-ZULU NATAL

67 ALBERSVILLE ROAD

PORT SHEPSTONE, 4240

TEL : 039 032 0003

FAX : 039 682 7510

MOBILE : 082 554 3427

BRANCH: EASTERN CAPE

OFFICE No. 2, FYNN HOUSE

STREET No. 6

BIZANA, 4800

TEL: 039 251 0476

FAX: 086 577 7713

✉ P. O. BOX 455, PORT SHEPSTONE, 4240

e-mail: vhb@vhbassociates.co.za

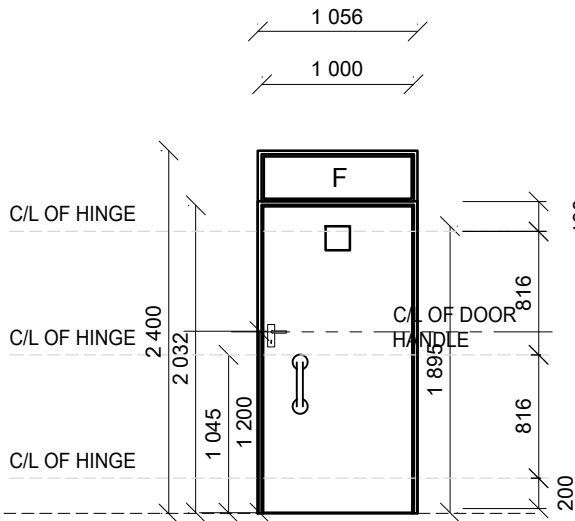

**DOOR TYPE
D 9**

DOOR DESCRIPTION

1000 x 2032 x 44mm THICK SEMI-SOLID FLUSH DOOR WITH 3.2mm TEMPERED HARDBOARD FACINGS AND 4 HARDWOOD EDGE STRIPS. DOOR MANUFACTURED ACCORDING TO SANS 545

TO TIMBER:
CAREFULLY CLEAN AND PREPARE ALL SURFACES, FINE SANDING AND ROUNDING OFF SHARP EDGES AS NECESSARY. REMOVE ALL PARTICLES AND WIPE THE SURFACE CLEAN OF DUST. 3 X COATS OF "KANSAI PLASCON" OR SIMILAR APPROVED WOODCARE EXTERIOR, PREMIUM QUALITY WATER-BASED COATING TO BE PROVIDED TO DOOR AS PER MANUFACTURER'S SPECIFICATIONS. LIGHT SAND PAPER BETWEEN COATS WITH 240 GRITS SANDPAPER AND ALLOW 24 HOURS FOR DRYING IN-BETWEEN EACH LAYER. COMPLETE APPLICATION TO "WOODCARE INSTRUCTIONS. COLOUR IMBUA TO BE APPROVED BY ARCHITECT.
NB: REMOVE ANY DUST BEFORE RE-COATING.

IRONMONGERY

- HINGES**
UNION OR SIMILAR APPROVED JH-BB-STD-2-55, 55 2BB BUTT HINGE EN 1935GRD 13 (THREE OF) WITH A STAINLESS STEEL FINISH, STAINLESS STEEL SCREWS TO BE PROVIDED
- DOOR CLOSER**
HOLD OPEN CLOSER DC300HO EN-3-6
- HANDLE**
2 x UNION STAINLESS STEEL 300mm PULL HANDLE FLANGE FIXED 22mm DIAMETER PRODUCT CODE PHD-CF-300-2255
- ROLLER CATCH**
1 x ADJUSTABLE ROLLER CATCH PRODUCT CODE ARC 1 8255
- INDICATOR BOLT**
1 x UNION INDICATOR FACILITY BOLT PRODUCT CODE 3765 1 A5
- COAT HOOK & DOOR STOP**
1 x UNION HAT AND COAT HOOK WITH BUFFER PRODUCT CODE AND 1 x UNION DOOR STOP WITH SATIN FINISH PRODUCT CODE 8700 155 55802555
- KICKPLATE & DOOR SIGN**
1 x PARAPLEGIC TOILET SIGN PRODUCT AL5066-06ASE 1 4
2 X 700 x 800 x 2mm - AL5089-700W

FRAME

FRAME:
1.2MM ELECTRO - GALVANISED STEEL DOOR FRAME, SAMPLE TO BE APPROVED BY ARCHITECT PRIOR TO INSTALLATION. FRAME TO SUIT WALL THICKNESS

BREAKDOWN OF TOTAL

NO. REQUIRED	LHS	RHS
BLOCK A	---	01
BLOCK C	---	01
TOTAL	---	02

CLIENT:



DRAWING:

**BULWER P.S.
DOOR SCHEDULE**

JOB No.
CDC 19/01

SHEET No.
DOOR 9

REV.
C



ARCHITECTURE & PROJECT MANAGEMENT

HEAD OFFICE: KWA-ZULU NATAL **BRANCH: EASTERN CAPE**
67 ALBERSVILLE ROAD OFFICE No. 2, FYNN HOUSE
PORT SHEPSTONE, 4240 STREET No. 6
TEL : 039 032 0003 BIZANA, 4800
FAX : 039 682 7510 TEL: 039 251 0476
MOBILE : 082 554 3427 FAX: 086 577 7713

✉ P. O. BOX 455, PORT SHEPSTONE, 4240
e-mail: vhb@vhbassociates.co.za

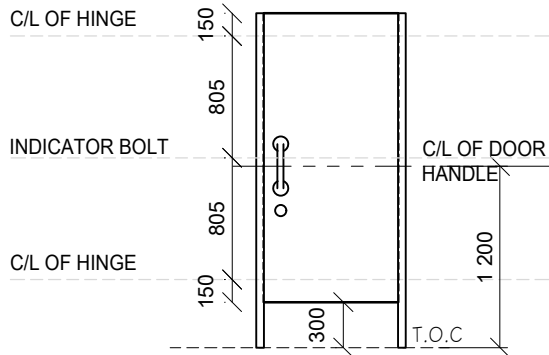

**DOOR TYPE
D 10**

DOOR DESCRIPTION

813 x 2032 x 44mm THICK SEMI-SOLID FLUSH DOOR WITH 3.2mm TEMPERED HARDBOARD FACINGS AND 4 HARDWOOD EDGE STRIPS. DOOR MANUFACTURED ACCORDING TO SANS 545

TO TIMBER:

CAREFULLY CLEAN AND PREPARE ALL SURFACES, FINE SANDING AND ROUNDING OFF SHARP EDGES AS NECESSARY. REMOVE ALL PARTICLES AND WIPE THE SURFACE CLEAN OF DUST. 3 X COATS OF "KANSAI PLASCON" OR SIMILAR APPROVED WOODCARE EXTERIOR, PREMIUM QUALITY WATER-BASED COATING TO BE PROVIDED TO DOOR AS PER MANUFACTURER'S SPECIFICATIONS. LIGHT SAND PAPER BETWEEN EACH LAYER. COMPLETE APPLICATION TO "WOODCARE INSTRUCTIONS. COLOUR IMBUA TO BE APPROVED BY ARCHITECT.

NB: REMOVE ANY DUST BEFORE RE-COATING.

IRONMONGERY

HINGES

UNION OR SIMILAR APPROVED JH-BB-STD-2-55, S5 2BB BUTT HINGE EN I 935GRD I 3 (THREE OF) WITH A STAINLESS STEEL FINISH. STAINLESS STEEL SCREWS TO BE PROVIDED

HANDLE

2 x UNION STAINLESS STEEL 300mm PULL HANDLE FLANGE FIXED 22mm DIAMETER PRODUCT CODE PHD-CF-300-2255

INDICATOR BOLT

1 x UNION INDICATOR FACILITY BOLT PRODUCT CODE 3765 I AS

COAT HOOK

1 x UNION HAT AND COAT HOOK WITH BUFFER PRODUCT CODE S5802555

KICKPLATE & DOOR SIGN

1 x PARAPLEGIC TOILET SIGN PRODUCT S5506-06555, OUTLINE ENGRAVED
2 X 900 x 800 x 1.2mm KICKPLATES - S55089-900W

FRAME

FRAME:

SELECTED 44mm X 114mm MERANTI DOOR FRAME EXCLUDING TOP FRAME

FINISH TO TIMBER:

CAREFULLY CLEAN AND PREPARE ALL SURFACES, FINE SANDING AND ROUNDING OFF SHARP EDGES AS NECESSARY. REMOVE ALL PARTICLES AND WIPE THE SURFACE CLEAN OF DUST. 3 X COATS OF "KANSAI PLASCON" OR SIMILAR APPROVED WOODCARE EXTERIOR, PREMIUM QUALITY WATER-BASED COATING TO BE PROVIDED TO DOOR AS PER MANUFACTURER'S SPECIFICATIONS. LIGHT SAND PAPER BETWEEN EACH LAYER. COMPLETE APPLICATION TO "WOODCARE INSTRUCTIONS. COLOUR IMBUA TO BE APPROVED BY ARCHITECT.

NB: REMOVE ANY DUST BEFORE RE-COATING.

BREAKDOWN OF TOTAL

NO. REQUIRED	LHS	RHS
BLOCK C	07	05
BLOCK D	16	---
BLOCK F	04	---
TOTAL	27	05

CLIENT:



DRAWING:

**BULWER P.S.
DOOR SCHEDULE**

JOB No.
CDC 19/01

SHEET No.
DOOR 10

REV.
C



ARCHITECTURE & PROJECT MANAGEMENT

HEAD OFFICE: KWA-ZULU NATAL

67 ALBERSVILLE ROAD

PORT SHEPSTONE, 4240

TEL : 039 032 0003

FAX : 039 682 7510

MOBILE : 082 554 3427

BRANCH: EASTERN CAPE

OFFICE No. 2, FYNN HOUSE

STREET No. 6

BIZANA, 4800

TEL: 039 251 0476

FAX: 086 577 7713

✉ P. O. BOX 455, PORT SHEPSTONE, 4240
e-mail: vhb@vhbassociates.co.za

DOOR DESCRIPTION

DOOR

POWDER COATED CHARCOAL GREY ALUMINIUM OF 25 MICRONS. FIXED ALUMINIUM PANEL TO BOTTOM HALF OF DOOR LEAVES.
ALL POWDER COATING SHALL BE EXECUTED ONLY BY APPLICATORS APPROVED BY THE POWDER MANUFACTURERS AND SHALL BE EXECUTED STRICTLY IN CONFORMANCE WITH SANS 1796.
A GUARANTEE OF NOT LESS THAN 10 YEARS IS TO BE PROVIDED AGAINST PEELING AND DISCOLOURATION.

FRAME

POWDER COATED CHARCOAL GREY ALUMINIUM

GLASS

1 2.38mm THICK CLEAR SAFETY GLAZING TO COMPLY WITH THE SANS 10400 PART N, SANS 0137, SANS 0400, SANS 1263 AND AAAMSA SELECTION GUIDE.

IRONMONGERY

HINGES

STAINLESS STEEL DOUBLE ACTION SPRING HINGE CAFE SELF CLOSING DOOR HINGE

LOCKSET

1 x UNION MORTICE HOOK LOCK 35mm BACKSET PRODUCT CODE QH35X85MM-SS

CYLINDER

1 x UNION 2X185CGMK CYLINDER PROFILE GMK

FLUSH BOLT

2 X UNION ALUMINIUM FLUSH BOLT FOR METAL DOORS PRODUCT CODEAL8208-180AS/MD

HANDLE

2 PAIRS UNION STAINLESS STEEL 600mm HIGH SAND PIPER PULL HANDLE, PRODUCT CODE 5920 BB

ESCUTCHEON

1 PAIR ART841C91 ESCUTCHEON CF CYLINDER PRODUCT CODE AL584-05AS

ROLLER CATCH

1 x ADJUSTABLE ROLLER CATCH PRODUCT CODE ARC118255

DOOR STOP

1 X DOOR STOP WITH SATIN FINISH PRODUCT CODE 8700155 PRODUCT CODE CZ8731CH

DUST PROOF STRIKE

1 x UNION DUST PROOF STRIKE PRODUCT CODE 88525C

KICKPLATE & DOOR SIGN

POWDER COATED CHARCOAL GREY ALUMINIUM R4 KICKPLATE OF 25 MICRONS.

NOTE: ALL EXTERNAL OPENING OUT DOORS TO HAVE 6mm COUNTER-SUNK SELF-TAPPING SCREW THROUGH PIN OF HINGE AS ANTI-THEFT DEVICE.

FRAME

FRAME

POWDER COATED CHARCOAL GREY ALUMINIUM FRAMED DOUBLE DOOR SECTIONS WITH KICKPLATE AND MIDRAIL ALL OF 25 MICRONS.

FINISH TO FRAME

POWDER COATED CHARCOAL GREY ALUMINIUM AND R4 KICKPLATE OF 25 MICRONS.

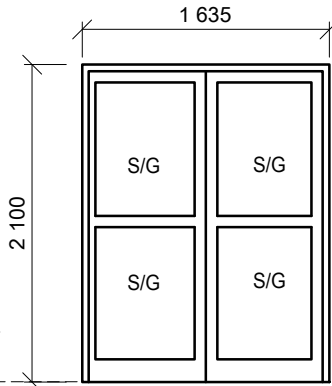

**DOOR TYPE
D 11**

BREAKDOWN OF TOTAL

NO. REQUIRED	
BLOCK C	02
TOTAL	02

CLIENT:



DRAWING:

**BULWER P.S.
DOOR SCHEDULE**

JOB No.
CDC 19/01

SHEET No.
DOOR 11

REV.
C



ARCHITECTURE & PROJECT MANAGEMENT

HEAD OFFICE: KWA-ZULU NATAL

67 ALBERSVILLE ROAD
PORT SHEPSTONE, 4240

TEL : 039 032 0003

FAX : 039 682 7510

MOBILE : 082 554 3427

BRANCH: EASTERN CAPE

OFFICE No. 2, FYNN HOUSE
STREET No. 6

BIZANA, 4800

TEL: 039 251 0476

FAX: 086 577 7713

✉ P. O. BOX 455, PORT SHEPSTONE, 4240
e-mail: vhb@vhbassociates.co.za

DOOR DESCRIPTION

DOOR SIZE: EACH LEAF - 813mm x 2,032mm x 44mm

SOLID HARDWOOD MERANTI FRAMED, LEDGED, BRACED & BATTENED DOOR BY SPECIALISTS WITH REBATED MEETING STYLES AND 6mm MERANTI VENEER BACKING FITTED TO BACK OF DOOR RECESSED INTO FRAME.

TO TIMBER:

CAREFULLY CLEAN AND PREPARE ALL SURFACES, FINE SANDING AND ROUNDING OFF SHARP EDGES AS NECESSARY. REMOVE ALL PARTICLES AND WIPE THE SURFACE CLEAN OF DUST. 3 X COATS OF "KANSAI PLASCON" OR SIMILAR APPROVED WOODCARE EXTERIOR, PREMIUM QUALITY WATER-BASED COATING TO BE PROVIDED TO DOOR AS PER MANUFACTURER'S SPECIFICATIONS. LIGHT SAND PAPER BETWEEN COATS WITH 240 GRITS SANDPAPER AND ALLOW 24 HOURS FOR DRYING IN-BETWEEN EACH LAYER. COMPLETE APPLICATION TO "WOODCARE INSTRUCTIONS. COLOUR IMBUJA TO BE APPROVED BY ARCHITECT. NB: REMOVE ANY DUST BEFORE RE-COATING.

IRONMONGERY

FLUSH BOLT

UNION OR EQUAL APPROVED AL8208-150AS ART 208C91 U/FLUSH BOLT 150MM WITH ANODISED FINISH

DUST PROOF STRIKE

UNION OR EQUAL APPROVED 88525C DUST PROOF STRIKE

LOCKSET

UNION OR SIMILAR APPROVED 4 LEVER LOCKSET - 5C, SATIN CHROME FINISHED PRODUCT CODE CZ682246 15C, REBATE CONVERSION SET TO BE PROVIDED.

HINGES AND DOOR STOP

UNION OR EQUAL APPROVED PARLIAMENT HINGES (THREE OF), STAINLESS STEEL SCREWS TO BE PROVIDED

2 X DOOR STOP WITH SATIN FINISH PRODUCT CODE 8700155 PRODUCT CODE CZ8731CH

FRAME

FRAME:

1.2MM ELECTRO - GALVANISED STEEL DOOR FRAME, SAMPLE TO BE APPROVED BY ARCHITECT PRIOR TO INSTALLATION. FRAME TO SUIT WALL THICKNESS

BREAKDOWN OF TOTAL

NO. REQUIRED	
BLOCK C	01
TOTAL	01

DOOR TYPE
D 12

CLIENT:



DRAWING:

BULWER P.S.
DOOR SCHEDULE

JOB No.
CDC 19/01

SHEET No.
DOOR 12

REV.
C



ARCHITECTURE & PROJECT MANAGEMENT

HEAD OFFICE: KWA-ZULU NATAL

BRANCH: EASTERN CAPE

67 ALBERSVILLE ROAD

OFFICE No. 2, FYNN HOUSE

PORT SHEPSTONE, 4240

STREET No. 6

TEL : 039 032 0003

BIZANA, 4800

FAX : 039 682 7510

TEL: 039 251 0476

MOBILE : 082 554 3427

FAX: 086 577 7713

☒ P. O. BOX 455, PORT SHEPSTONE, 4240
e-mail: vhb@vhbassociates.co.za

DOOR / FRAME DESCRIPTION

"CHUBB" PHOENIX 900 OR OTHER APPROVED RECORD ROOM DOOR AND FRAME COMPLETE WITH MECHANISM AND FIXING LUGS INCLUDING BEDDING IN POSITION INTO WALL OPENING 900 x 1,935mm HIGH INCLUDING "CHUBB" DOORSTOP FIXED TO FLOOR.

OTHER

2 x "CHUBB" OR OTHER APPROVED DOUBLE SIDED VENTILATORS SIZE: 185 x 185mm AND BUILT THROUGH WALL.

FINISH

FINISH:
APPLY 1 X COAT DULUX OR SIMILAR APPROVED STEEL PRIMER, 1 X UNIVERSAL UNDERCOAT AND 2 X DULUX PEARLGLO WATERBASED TINTED TOUGH WATERBORNE SATIN ENAMEL FOR EXTERIOR USE
NB: ALLOW MINIMUM OF 4 HOURS DRYING TIME BETWEEN EACH COAT AS PER MANUFACTURER'S SPECIFICATION.

BREAKDOWN OF TOTAL

NO. REQUIRED	LHS	RHS
BLOCK C	---	01
TOTAL	---	01

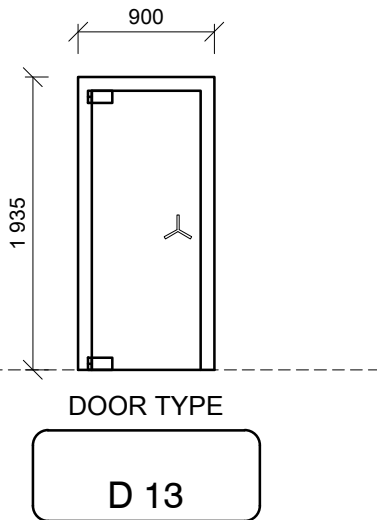

CLIENT:



DRAWING:

**BULWER P.S.
DOOR SCHEDULE**

JOB No.
CDC 19/01

SHEET No.
DOOR 13

REV.
C



ARCHITECTURE & PROJECT MANAGEMENT

HEAD OFFICE: KWA-ZULU NATAL

67 ALBERSVILLE ROAD

PORT SHEPSTONE, 4240

TEL : 039 032 0003

FAX : 039 682 7510

MOBILE : 082 554 3427

BRANCH: EASTERN CAPE

OFFICE No. 2, FYNN HOUSE

STREET No. 6

BIZANA, 4800

TEL: 039 251 0476

FAX: 086 577 7713

✉ P. O. BOX 455, PORT SHEPSTONE, 4240
e-mail: vhb@vhbassociates.co.za

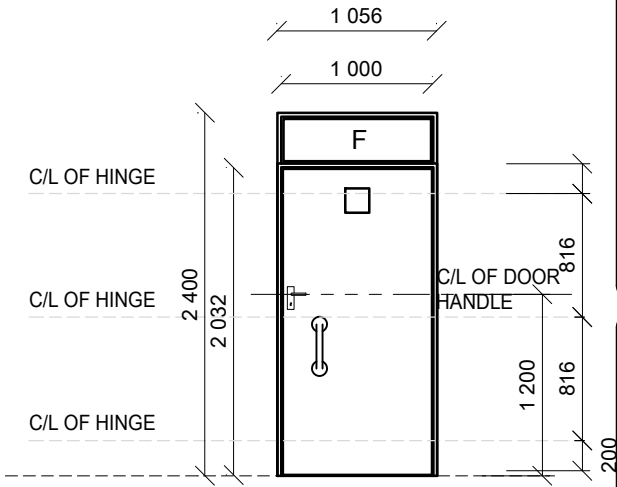

**DOOR TYPE
D 14**

DOOR DESCRIPTION

1 000 x 2032 x 44mm THICK SEMI-SOLID FLUSH DOOR WITH 3.2mm TEMPERED HARDBOARD FACINGS AND 4 HARDWOOD EDGE STRIPS. DOOR MANUFACTURED ACCORDING TO SANS 545

TO TIMBER:
CAREFULLY CLEAN AND PREPARE ALL SURFACES, FINE SANDING AND ROUNDING OFF SHARP EDGES AS NECESSARY. REMOVE ALL PARTICLES AND WIPE THE SURFACE CLEAN OF DUST. 3 X COATS OF "KANSAI PLASCON" OR SIMILAR APPROVED WOODCARE EXTERIOR, PREMIUM QUALITY WATER-BASED COATING TO BE PROVIDED TO DOOR AS PER MANUFACTURER'S SPECIFICATIONS. LIGHT SAND PAPER BETWEEN COATS WITH 240 GRITS SANDPAPER AND ALLOW 24 HOURS FOR DRYING IN-BETWEEN EACH LAYER. COMPLETE APPLICATION TO "WOODCARE INSTRUCTIONS. COLOUR IMBUIA TO BE APPROVED BY ARCHITECT.
NB: REMOVE ANY DUST BEFORE RE-COATING.

IRONMONGERY

- HINGES
UNION OR SIMILAR APPROVED JH-BB-STD-2-55, 55 2BB BUTT HINGE EN 1935GRD 13 (THREE OF) WITH A STAINLESS STEEL FINISH, STAINLESS STEEL SCREWS TO BE PROVIDED
- DOOR CLOSER
HOLD OPEN CLOSER DC300HO EN-3-6
- HANDLE
2 x UNION STAINLESS STEEL 300mm PULL HANDLE FLANGE FIXED 22mm DIAMETER PRODUCT CODE PHD-CF-300-2255
- ROLLER CATCH
1 x ADJUSTABLE ROLLER CATCH PRODUCT CODE ARC 1 8255
- INDICATOR BOLT
1 x UNION INDICATOR FACILITY BOLT PRODUCT CODE 3765 1A5
- COAT HOOK & DOOR STOP
1 x UNION HAT AND COAT HOOK WITH BUFFER PRODUCT CODE AND 1 x UNION DOOR STOP WITH SATIN FINISH PRODUCT CODE 8700 155 55802555
- KICKPLATE & DOOR SIGN
1 x PARAPLEGIC TOILET SIGN PRODUCT AL5066-06ASE 14
2 X 700 x 800 x 2mm - AL5089-700W

FRAME

SELECTED 55 x 90 MERANTI DOOR FRAME AND 68mm BULLNOSE ARCHITRAVES

BREAKDOWN OF TOTAL

NO. REQUIRED	LHS	RHS
BLOCK D	01	01
TOTAL	01	01

CLIENT:



DRAWING:

**BULWER P.S.
DOOR SCHEDULE**

JOB No.
CDC 19/01

SHEET No.
DOOR 14

REV.
C



ARCHITECTURE & PROJECT MANAGEMENT

HEAD OFFICE: KWA-ZULU NATAL
67 ALBERSVILLE ROAD
PORT SHEPSTONE, 4240
TEL : 039 032 0003
FAX : 039 682 7510
MOBILE : 082 554 3427

BRANCH: EASTERN CAPE
OFFICE No. 2, FYNN HOUSE
STREET No. 6
BIZANA, 4800
TEL: 039 251 0476
FAX: 086 577 7713

✉ P. O. BOX 455, PORT SHEPSTONE, 4240
e-mail: vhb@vhbassociates.co.za

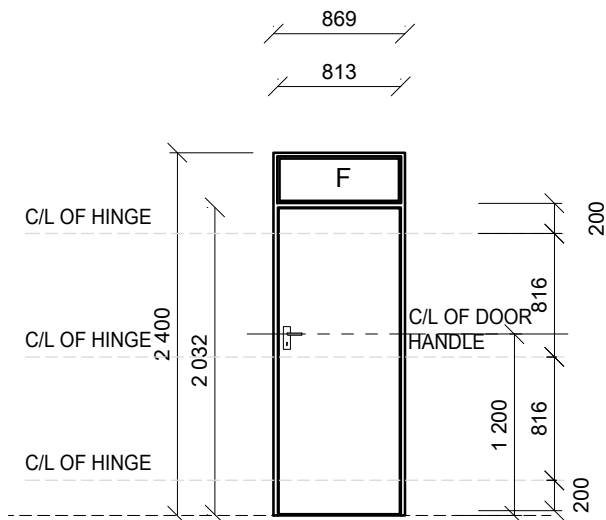

**DOOR TYPE
D 15**

DOOR DESCRIPTION

SEMI-SOLID FLUSH DOOR WITH 3.2mm TEMPERED HARDBOARD FACINGS AND 4 HARDWOOD EDGE STRIPS. DOOR MANUFACTURED ACCORDING TO SANS 545

DOOR SIZE: 813mm x 2,032mm x 44mm TO FIT 900mm WIDE OPENINGS ALL OPENINGS TO EXISTING DOOR TO BE MEASURED PRIOR TO MANUFACTURING, FRAME TO BE MANUFACTURED TO SUIT EITHER 110mm OR 230mm WALL AS PER FLOOR PLA

TO TIMBER:

CAREFULLY CLEAN AND PREPARE ALL SURFACES, FINE SANDING AND ROUNDING OFF SHARP EDGES AS NECESSARY. REMOVE ALL PARTICLES AND WIPE THE SURFACE CLEAN OF DUST. 3 X COATS OF "KANSAI PLASCON" OR SIMILAR APPROVED WOODCARE EXTERIOR, PREMIUM QUALITY WATER-BASED COATING TO BE PROVIDED TO DOOR AS PER MANUFACTURER'S SPECIFICATIONS. LIGHT SAND PAPER BETWEEN COATS WITH 240 GRITS SANDPAPER AND ALLOW 24 HOURS FOR DRYING IN-BETWEEN EACH LAYER. COMPLETE APPLICATION TO "WOODCARE INSTRUCTIONS. COLOUR IMBUJA TO BE APPROVED BY ARCHITECT.
NB: REMOVE ANY DUST BEFORE RE-COATING.

FANLIGHT

4mm CLEAR FLOAT GLAZING TO COMPLY WITH PART N SANS 10400 TO FORM FANLIGHT

IRONMONGERY

LOCKSET

UNION OR SIMILAR APPROVED 4 LEVER LOCKSET - SC, SATIN CHROME FINISHED PRODUCT CODE CZ68224G15C

HINGES EXCEPT FOR SHOWER DOORS.

UNION OR SIMILAR APPROVED JH-BB-STD-2-55, 55 2BB BUTT HINGE EN1935GRD13 (THREE OF) WITH A STAINLESS STEEL FINISH, STAINLESS STEEL SCREWS TO BE PROVIDED, EXCEPT FOR SHOWER DOORS.

DOOR STOP

1 X DOOR STOP WITH SATIN FINISH PRODUCT CODE 8700155 PRODUCT CODE CZ8731CH

TO SHOWER DOOR IN BLOCK 1 ONLY - STAINLESS STEEL DOUBLE ACTION SPRING HINGE CAFE SELF CLOSING DOOR HINGE TO BLOCKS 5 AND 7, EXISTING FRAMES TO BE MAINTAINED AND EXISTING PAINT TO BE CAREFULLY STRIPPED OFF, NEW DOOR TO BE PROVIDED

FRAME

FRAME:

SELECTED 55 x 90 MERANTI DOOR FRAME AND 68mm BULLNOSE ARCHITRAVES

BREAKDOWN OF TOTAL

NO. REQUIRED	LHS	RHS
BLOCK C	01	01
BLOCK D	---	02
TOTAL	01	03

CLIENT:



DRAWING:

**BULWER P.S.
DOOR SCHEDULE**

JOB No.
CDC 19/01

SHEET No.
DOOR 15

REV.
C



ARCHITECTURE & PROJECT MANAGEMENT

HEAD OFFICE: KWA-ZULU NATAL

67 ALBERSVILLE ROAD
PORT SHEPSTONE, 4240

TEL : 039 032 0003

FAX : 039 682 7510

MOBILE : 082 554 3427

BRANCH: EASTERN CAPE

OFFICE No. 2, FYNN HOUSE
STREET No. 6

BIZANA, 4800

TEL: 039 251 0476

FAX: 086 577 7713

✉ P. O. BOX 455, PORT SHEPSTONE, 4240
e-mail: vhb@vhbassociates.co.za

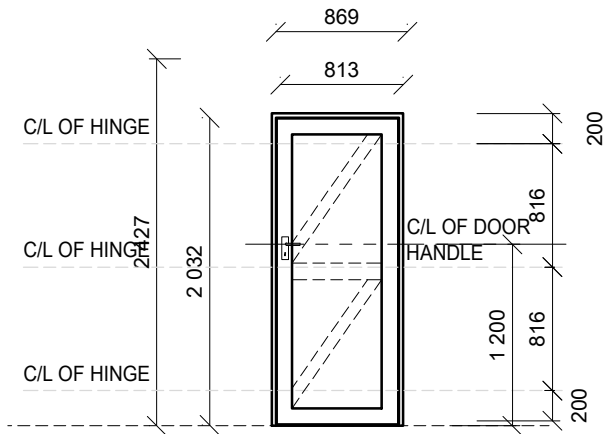
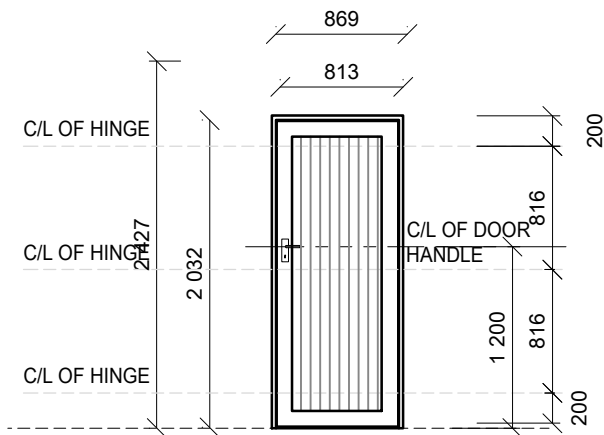

DOOR TYPE
D 16

DOOR DESCRIPTION

DOOR SIZE: 813MM X 2,032MM X 44MM
SOLID HARDWOOD MERANTI FRAMED, LEDGED, BRACED & BATTENED DOOR BY SPECIALISTS WITH 6mm MERANTI VENEER BACKING FITTED TO BACK OF DOOR RECESSED INTO FRAME.
MERANTI WEATHER BAR AND NYLON BRUSH STRIP TO BOTTOM OF DOOR EXTERNALLY.

TO TIMBER:
CAREFULLY CLEAN AND PREPARE ALL SURFACES, FINE SANDING AND ROUNDING OFF SHARP EDGES AS NECESSARY. REMOVE ALL PARTICLES AND WIPE THE SURFACE CLEAN OF DUST. 3 X COATS OF "KANSAI PLASCON" OR SIMILAR APPROVED WOODCARE EXTERIOR, PREMIUM QUALITY WATER-BASED COATING TO BE PROVIDED TO DOOR AS PER MANUFACTURER'S SPECIFICATIONS. LIGHT SAND PAPER BETWEEN COATS WITH 240 GRITS SANDPAPER AND ALLOW 24 HOURS FOR DRYING IN-BETWEEN EACH LAYER. COMPLETE APPLICATION TO "WOODCARE INSTRUCTIONS. COLOUR IMBUIA TO BE APPROVED BY ARCHITECT.
NB: REMOVE ANY DUST BEFORE RE-COATING.

FANLIGHT
4mm CLEAR FLOAT GLAZING TO COMPLY WITH PART N SANS 10400 TO FORM FANLIGHT

IRONMONGERY

LOCKSET
UNION OR SIMILAR APPROVED 4 LEVER LOCKSET - SC, SATIN CHROME FINISHED PRODUCT CODE CZ68224615C
HINGES EXCEPT FOR SHOWER DOORS.

UNION OR SIMILAR APPROVED JH-BB-STD-2-SS, SS 2BB BUTT HINGE EN1935GRD13 (THREE OF) WITH A STAINLESS STEEL FINISH, STAINLESS STEEL SCREWS TO BE PROVIDED, EXCEPT FOR SHOWER DOORS.

DOOR STOP
1 X DOOR STOP WITH SATIN FINISH PRODUCT CODE 8700155 PRODUCT CODE CZ8731CH

TO SHOWER DOOR IN BLOCK 1 ONLY - STAINLESS STEEL DOUBLE ACTION SPRING HINGE CAFE SELF CLOSING DOOR HINGE TO BLOCKS 5 AND 7, EXISTING FRAMES TO BE MAINTAINED AND EXISTING PAINT TO BE CAREFULLY STRIPPED OFF, NEW DOOR TO BE PROVIDED

FRAME:
SELECTED 55 x 90 MERANTI DOOR FRAME AND 68mm BULLNOSE ARCHITRAVES

BREAKDOWN OF TOTAL

NO. REQUIRED	LHS	RHS
BLOCK F	01	01
TOTAL	01	01

CLIENT:



DRAWING:

BULWER P.S.
DOOR SCHEDULE

JOB No.
CDC 19/01

SHEET No.
DOOR 16

REV.
C



ARCHITECTURE & PROJECT MANAGEMENT

HEAD OFFICE: KWA-ZULU NATAL

67 ALBERSVILLE ROAD

PORT SHEPSTONE, 4240

TEL : 039 032 0003

FAX : 039 682 7510

MOBILE : 082 554 3427

BRANCH: EASTERN CAPE

OFFICE No. 2, FYNN HOUSE

STREET No. 6

BIZANA, 4800

TEL: 039 251 0476

FAX: 086 577 7713

✉ P. O. BOX 455, PORT SHEPSTONE, 4240
e-mail: vhb@vhbassociates.co.za

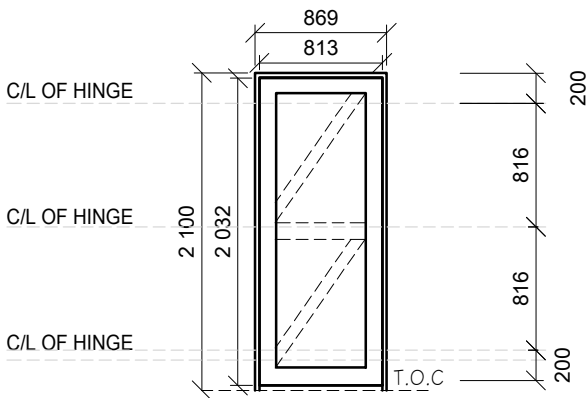
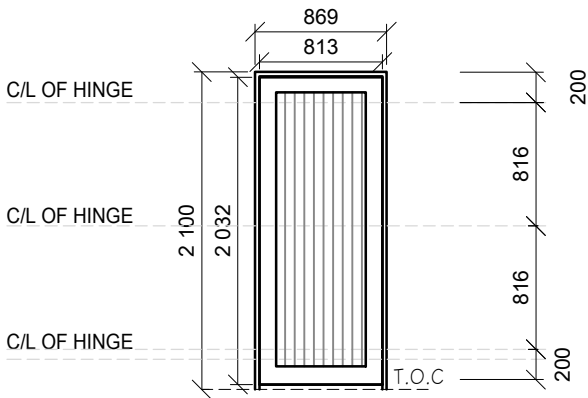

DOOR TYPE
D 17

DOOR DESCRIPTION

DOOR SIZE: 813mm x 2,032mm x 44mm
2 HOUR FIRE RATED SOLID HARDWOOD MERANTI FRAMED, LEDGED, BRACED & BATTENED DOOR BY SPECIALISTS WITH 6mm MERANTI VENEER BACKING FITTED TO BACK OF DOOR RECESSED INTO FRAME. MERANTI WEATHER BAR AND NYLON BRUSH STRIP TO BOTTOM OF DOOR EXTERNALLY.

TO TIMBER:

CAREFULLY CLEAN AND PREPARE ALL SURFACES, FINE SANDING AND ROUNDING OFF SHARP EDGES AS NECESSARY. REMOVE ALL PARTICLES AND WIPE THE SURFACE CLEAN OF DUST. 3 X COATS OF "KANSAI PLASCON" OR SIMILAR APPROVED WOODCARE EXTERIOR, PREMIUM QUALITY WATER-BASED COATING TO BE PROVIDED TO DOOR AS PER MANUFACTURER'S SPECIFICATIONS. LIGHT SAND PAPER BETWEEN COATS WITH 240 GRITS SANDPAPER AND ALLOW 24 HOURS FOR DRYING IN-BETWEEN EACH LAYER. COMPLETE APPLICATION TO "WOODCARE INSTRUCTIONS. COLOUR IMBUA TO BE APPROVED BY ARCHITECT. NB: REMOVE ANY DUST BEFORE RE-COATING.

IRONMONGERY

HINGES

3 X ALU RFLX HINGE 200mm BLK PAIRS PRODUCT CODE 8352-200BLK

PANIC LATCH

1 x DOUBLE PANIC BOLT, 1 200mm PRODUCT CODE J-88 I-W-SIL

NOTE: ALL EXTERNAL OPENING OUT DOORS TO HAVE 6mm COUNTER-SUNK SELF-TAPPING SCREW THROUGH PIN OF HINGE AS ANTI-THEFT DEVICE.

FRAME

FRAME:

1.2MM ELECTRO - GALVANISED STEEL DOOR FRAME, SAMPLE TO BE APPROVED BY ARCHITECT PRIOR TO INSTALLATION. FRAME TO SUIT WALL THICKNESS

BREAKDOWN OF TOTAL

NO. REQUIRED	LHS	RHS
BLOCK C	---	01
TOTAL	---	01

CLIENT:



DRAWING:

BULWER P.S.
DOOR SCHEDULE

JOB No.
CDC 19/01

SHEET No.
DOOR 17

REV.
C



ARCHITECTURE & PROJECT MANAGEMENT

HEAD OFFICE: KWA-ZULU NATAL

67 ALBERSVILLE ROAD

PORT SHEPSTONE, 4240

TEL : 039 032 0003

FAX : 039 682 7510

MOBILE : 082 554 3427

BRANCH: EASTERN CAPE

OFFICE No. 2, FYNN HOUSE

STREET No. 6

BIZANA, 4800

TEL: 039 251 0476

FAX: 086 577 7713

✉ P. O. BOX 455, PORT SHEPSTONE, 4240
e-mail: vhb@vhbassociates.co.za

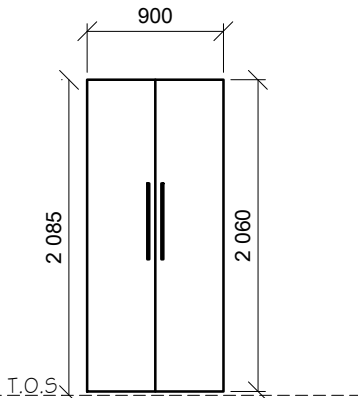

DOOR TYPE
D 18

DOOR DESCRIPTION

16mm SUPAWOOD WITH HIGH IMPACT EDGING TO FORM DOUBLE DOOR
 SAMPLE TO BE PROVIDED FOR APPROVAL

TO TIMBER:

CAREFULLY CLEAN AND PREPARE ALL SURFACES, FINE SANDING AND ROUNDING OFF SHARP EDGES AS NECESSARY. REMOVE ALL PARTICLES AND WIPE THE SURFACE CLEAN OF DUST. 3 X COATS OF "KANSAI PLASCON" OR SIMILAR APPROVED WOODCARE EXTERIOR, PREMIUM QUALITY WATER-BASED COATING TO BE PROVIDED TO DOOR AS PER MANUFACTURER'S SPECIFICATIONS. LIGHT SAND PAPER BETWEEN COATS WITH 240 GRITS SANDPAPER AND ALLOW 24 HOURS FOR DRYING IN-BETWEEN EACH LAYER. COMPLETE APPLICATION TO "WOODCARE INSTRUCTIONS. COLOUR IMBUA TO BE APPROVED BY ARCHITECT.
 NB: REMOVE ANY DUST BEFORE RE-COATING.

IRONMONGERY

HANDLES

2 PAIRS UNION STAINLESS STEEL 600mm HIGH SAND PIPER PULL HANDLE, PRODUCT CODE 5920 BB

HINGES

WIDE ANGLE - FULL OVERLAY / 165° HINGE -
 4 HINGES PER LEAF. SAMPLE TO BE PROVIDED FOR APPROVAL

FRAME

50 x 16mm SUPAWOOD WITH HIGH IMPACT EDGING FIXED TO WALLS TO FORM FRAME

BREAKDOWN OF TOTAL

NO. REQUIRED	
BLOCK C	02
TOTAL	02

CLIENT:



DRAWING:

BULWER P.S.
DOOR SCHEDULE

JOB No.
CDC 19/01

SHEET No.
DOOR 18

REV.
A



ARCHITECTURE & PROJECT MANAGEMENT

HEAD OFFICE: KWA-ZULU NATAL
 67 ALBERSVILLE ROAD
 PORT SHEPSTONE, 4240
 TEL : 039 032 0003
 FAX : 039 682 7510
 MOBILE : 082 554 3427

BRANCH: EASTERN CAPE
 OFFICE No. 2, FYNN HOUSE
 STREET No. 6
 BIZANA, 4800
 TEL: 039 251 0476
 FAX: 086 577 7713

✉ P. O. BOX 455, PORT SHEPSTONE, 4240
 e-mail: vhb@vhbassociates.co.za

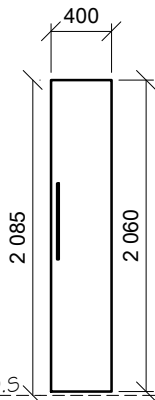

DOOR TYPE
D 19

DOOR DESCRIPTION

16mm SUPAWOOD WITH HIGH IMPACT EDGING TO FORM DOUBLE DOOR SAMPLE TO BE PROVIDED FOR APPROVAL

TO TIMBER:
CAREFULLY CLEAN AND PREPARE ALL SURFACES, FINE SANDING AND ROUNDING OFF SHARP EDGES AS NECESSARY. REMOVE ALL PARTICLES AND WIPE THE SURFACE CLEAN OF DUST. 3 X COATS OF "KANSAI PLASCON" OR SIMILAR APPROVED WOODCARE EXTERIOR, PREMIUM QUALITY WATER-BASED COATING TO BE PROVIDED TO DOOR AS PER MANUFACTURER'S SPECIFICATIONS. LIGHT SAND PAPER BETWEEN COATS WITH 240 GRITS SANDPAPER AND ALLOW 24 HOURS FOR DRYING IN-BETWEEN EACH LAYER. COMPLETE APPLICATION TO "WOODCARE INSTRUCTIONS. COLOUR IMBUJA TO BE APPROVED BY ARCHITECT.
NB: REMOVE ANY DUST BEFORE RE-COATING.

IRONMONGERY

HANDLES
2 PAIRS UNION STAINLESS STEEL 600mm HIGH SAND PIPER PULL HANDLE, PRODUCT CODE 5920 BB
HINGES
WIDE ANGLE - FULL OVERLAY / 165° HINGE -
4 HINGES PER LEAF. SAMPLE TO BE PROVIDED FOR APPROVAL

FRAME

50 x 16mm SUPAWOOD WITH HIGH IMPACT EDGING FIXED TO WALLS TO FORM FRAME

BREAKDOWN OF TOTAL

NO. REQUIRED	LHS	RH
BLOCK C	---	01
TOTAL	---	01

CLIENT:



DRAWING:

BULWER P.S.
DOOR SCHEDULE

JOB No.
CDC 19/01

SHEET No.
DOOR 19

REV.
A



ARCHITECTURE & PROJECT MANAGEMENT

HEAD OFFICE: KWA-ZULU NATAL
67 ALBERSVILLE ROAD
PORT SHEPSTONE, 4240
TEL : 039 032 0003
FAX : 039 682 7510
MOBILE : 082 554 3427

BRANCH: EASTERN CAPE
OFFICE No. 2, FYNN HOUSE
STREET No. 6
BIZANA, 4800
TEL: 039 251 0476
FAX: 086 577 7713

✉ P. O. BOX 455, PORT SHEPSTONE, 4240
e-mail: vhb@vhbassociates.co.za

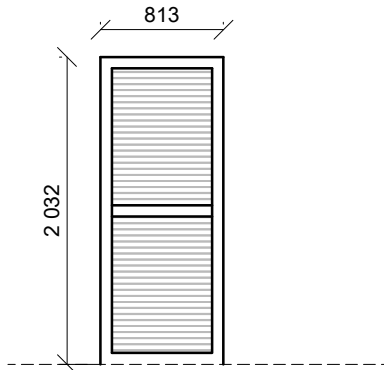

DOOR DESCRIPTION

GMS OR SIMILAR APPROVED PRE-GALVANISED MILD STEEL AND ARE HUNG TO A PRE-GALVANISED MILD STEEL FRAME MADE FROM 1.6MM THICK STEEL USING HEAVY DUTY HINGES

BREAKDOWN OF TOTAL

NO. REQUIRED	LHS	RH
BLOCK I	01	---
TOTAL	01	---

CLIENT:



DRAWING:

**BULWER P.S.
DOOR SCHEDULE**

JOB No.
CDC 19/01

SHEET No.
DOOR 20

REV.
A



ARCHITECTURE & PROJECT MANAGEMENT

HEAD OFFICE: KWA-ZULU NATAL

67 ALBERSVILLE ROAD
PORT SHEPSTONE, 4240

TEL : 039 032 0003

FAX : 039 682 7510

MOBILE : 082 554 3427

BRANCH: EASTERN CAPE

OFFICE No. 2, FYNN HOUSE

STREET No. 6

BIZANA, 4800

TEL: 039 251 0476

FAX: 086 577 7713

✉ P. O. BOX 455, PORT SHEPSTONE, 4240
e-mail: vhb@vhbassociates.co.za