

**Humansrus Solar 4 (Pty) Ltd.
Solar PV farm development.**

March 29

2016

Engineering overview and summary pertaining to environmental aspects of the Humansrus Solar 4 (Pty) Ltd. solar PV development. Compiled by Solek Renewable Energy Engineers.

**Draft Impact Assessment
Engineering Report**

Contents

Contents.....	2
List of Figures	4
List of Tables	4
Abbreviations and Acronyms.....	5
1 Introduction	6
1.1 Background of the energy market in South Africa.....	6
1.2 Opportunity for solar energy in the Northern Cape	7
1.3 Overview of the proposed project.....	8
2 Solar energy as a power generation technology	9
2.1 Basic understanding of solar PV plants.....	9
2.2 Project-related benefits	10
3 Description of the proposed solar facility.....	10
3.1 Site development components.....	11
3.1.1 <i>Position of solar facilities</i>	12
3.1.2 <i>Foundation footprint</i>	12
3.1.3 <i>Module height</i>	13
3.1.4 <i>Solar Module Area</i>	13
3.1.5 <i>Access road to site</i>	13
3.1.6 <i>Internal roads indication width</i>	13
3.1.7 <i>Inverter Rooms</i>	14
3.1.8 <i>On-site substations and transformers</i>	14
3.1.9 <i>Cable routes and trench dimensions</i>	15
3.1.10 <i>Connection routes to the distribution/transmission network</i>	15
3.1.11 <i>Security fence</i>	15
3.1.12 <i>Cut and fill areas</i>	15
3.1.13 <i>Borrow pits</i>	15
3.1.14 <i>Soil heaps</i>	16
3.1.15 <i>Auxiliary buildings area</i>	16
3.1.16 <i>Fuel storage</i>	16
3.1.17 <i>Fire management and protection area</i>	17
3.1.18 <i>Laydown area</i>	17
3.2 Project alternatives.....	17
3.2.1 Site alternatives	17

3.2.2	Layout alternatives.....	17
3.2.3	Technology alternatives.....	18
3.2.4	Mounting and film alternatives.....	20
3.2.5	The “do-nothing” alternative.....	21
3.3	Access to facility.....	21
3.4	Water related items.....	23
3.4.1	Water requirements.....	23
3.4.2	Water sources.....	24
3.4.3	Water buffer.....	25
3.4.4	Water-use permission.....	25
3.4.5	Erosion and storm water control.....	25
3.5	Grid connection.....	29
3.6	Services Required.....	30
3.6.1	Water.....	30
3.6.2	Electricity.....	30
3.6.3	Waste, emission and noise management.....	31
4	Construction of the proposed facility.....	31
4.1	Traffic management and transportation.....	32
4.2	Establishment of internal access roads on the farm.....	34
4.3	Site preparation.....	34
4.4	Erecting of solar PV modules.....	35
4.5	Construct on-site substation.....	36
4.6	Establishment of additional infrastructure.....	36
4.7	Connect on-site substation to power grid.....	37
4.8	Undertake site remediation.....	38
5	Project operation and maintenance phase.....	38
6	Project decommission phase.....	38
7	Cost implications & revenue.....	39
7.1	Project cost overview.....	39
7.2	Project specific costs.....	39
7.3	Revenue streams.....	39
8	Project programme and timelines.....	40
9	Conclusion.....	41

List of Figures

Figure 1: South African solar irradiation distribution	8
Figure 2: Typical solar PV plant diagram.....	9
Figure 3: A typical layout of a solar PV plant	11
Figure 4: Typical PV module layout (PV and CSP)	12
Figure 5: Foundation footprint	12
Figure 6: Typical internal road example.....	14
Figure 7: Typical inverter room.....	14
Figure 8: Typical on-site substation footprint.....	14
Figure 9: Typical cable trenches.....	15
Figure 10: PV mounting structures scenarios	20
Figure 11: Access road alternatives for the proposed site	22
Figure 12: Typical water storage tank.....	25
Figure 13: Illustration of current vegetation on the farm.....	27
Figure 14: Installed concrete pipes and culverts	27
Figure 15: Temporary culvert inlet and outlet.....	27
Figure 16: Storm water flow	28
Figure 17: Causeway (Low Level River Crossing)	28
Figure 18: Illustration of a typical site after preparation.....	35
Figure 19: On-site construction of the PV arrays.....	35
Figure 20 : Typical on-site substation	36
Figure 21: The different connection alternatives	37

List of Tables

Table 1: REIPPPP bidding round dates.....	7
Table 2: Component size and percentage for the proposed 75MW _p	11
Table 3: Technology comparisson (CPV and PV) - advantages and disadvantages	19
Table 4: REIPPPP timelines (Round 6).....	40

Abbreviations and Acronyms

- AC Alternating Current
- BA Basic Assessment
- CPV Concentrated Photovoltaic
- CSP Concentrated Solar Power
- DC Direct Current
- DEA National Department of Environmental Affairs
- DAFF Department of Agriculture, Forestry & Fisheries
- DWA Department of Water Affairs
- EA Environmental Authorisation
- EAP Environmental Assessment Practitioner
- EIA Environmental Impact Assessment
- EMP Environmental Management Plan
- IPP Independent Power Producer
- IPPPP Independent Power Producer Procurement Programme
- PPA Power Purchase Agreement
- LV Low Voltage
- MV Medium Voltage
- MW Mega Watt (Power)
- MW_p Mega Watt Peak (Maximum peak power production)
- NEMA National Environmental Management Act
- NERSA National Energy Regulator of South Africa
- PV Photovoltaic
- REIPPPP Renewable Energy Independent Power Producer Procurement Programme
- SID Strategically Important Development
- SANRAL South African National Roads Agency Limited
- UNFCCC United Nations Framework Convention on Climate Change

1 Introduction

Humansrus Solar 4 (Pty) Ltd. solar PV energy facility, as an Independent Power Producer (IPP), is proposing the establishment of a commercial solar energy facility on a site within the Northern Cape to be known as Humansrus Solar 4 (Pty) Ltd. The project is planned to be located on the Farm 147, Humansrus. The farm is situated approximately 10 kilometres east of Copperton within the Northern Cape. The solar PV energy facility has a planned installed electrical capacity of 75 MW_p.

The Northern Cape is generally known to be one of the best preferred areas for the generation of solar energy in South Africa and even in the world because of abundant solar radiation. The purpose of this facility is to generate electricity from a renewable energy source (i.e. solar radiation) to provide power to the national electricity grid. The proposed development site is located within the Siyathemba local Municipality and Pixley ka Seme district approximately 10km east of Copperton.

The purpose of this engineering report is to describe the various sections of the facility and provide a transparent view on facility construction, operation, maintenance and the possible effects on the environment. Solek, a renewable energy engineering company, is primarily responsible for the compilation of this section of the report.

The report gives background on the energy market in South Africa, the significance of the renewable energy sector in this context and the opportunity for solar energy in the Northern Cape. The overall project and proposed facility is described in more detail by investigating the following key points:

- High-level overview of the South African energy sector
- The basic understanding of solar PV plants
- The description of the proposed solar facility
- The different steps in the construction phase of the proposed facility
- The project operation and maintenance phase
- Financial implications and financial overview
- Planned project timelines
- Overall conclusion

1.1 Background of the energy market in South Africa

The renewable energy market in South Africa has gained considerable momentum since the inception of the governmental subsidy program known as “South African Renewable Energy Independent Power Producers Procurement Program” (REIPPP). The established “Renewable Energy Independent Power Producers Program” (REIPPP) is widely and internationally regarded as a very successful program for the realisation of renewable energy projects, by the private sector. The development of the renewable energy sector is seen as one of the key development areas and industries within South Africa. In addition, the security of energy supply and sustainability thereof is seen as critical and strategic importance by the South African government.

The fourth round of the projects have been awarded and construction of Solar energy projects (“Photovoltaic” (PV); “Concentrated Photovoltaic” (CPV) and “Concentrated Solar Power” (CSP)) and Wind Energy projects planned and to commence in the near future. The fifth round submission of bids and tender submissions originally planned for mid-August 2015. After announcements of round 4 REIPPPP projects in early April 2015, additional allocation was given for post-Round 4 rounds.

The “Department of Energy” (DOE) launched additional Round 4 rounds in the form of Round 4B (additional capacity allocation of 1000MW, announced at the start June 2015) and expedited Round (additional capacity of 1800MW, opened for bidding dated 6 October 2015). After the first revised bidding date changed to 1 October the second revised bidding date as per briefing note 36 was postponed to the 11th of November 2015. Round 6 submission date is expected for the second half of 2016.

According to the governmental developed twenty year energy plan for South Africa, Integrated Resource Plan 2010 (IRP 2010-2030), South Africa is expected to require 42 500 MW of additional energy over the following 20 years in order to meet the requirements created by the growing economy.

The Renewable Energy Independent Power Producer Programme initially made 3725 MW of power available to be generated as part of a first phase initiative for renewable energy projects, aimed to be online by 2015. In December 2012 the Department of Energy announced a further 3200 MW of renewable energy aimed to be online by 2020. The first four bidding windows (up to round 4B) have taken up approximately 6000 MW of this target, equating to a remaining 900MW of the 6925MW (pre-round 4 allocation). The “Department of Energy” (DOE) announced an additional allocation of approximately 2800MW, increasing the total allocation made by the DOE to 9725MW. A total estimated available allocation left after the announcement of the 4B preferred bidders are approximately 2600MW (Round 4c and Round 5).

The Department of Energy (DoE) has set a number of dates for the submission of bid documents for private companies to apply for a licence to generate electricity. The bidding deadlines for the first four stages were as follow:

Table 1: REIPPPP bidding round dates

REIPPPP Bidding round	Bidding Date
1 st Bid Submission	4 November 2011
2 nd Bid Submission	5 March 2012
3 rd Bid Submission	19 August 2013
4 th Bid Submission	18 August 2014
4 th Expedited (5 th Bid Submission)	11 November 2015

The 6th Bid submission dates have not been confirmed but is expected for September 2016.

1.2 Opportunity for solar energy in the Northern Cape

When considering South Africa’s irradiation distribution, the Northern Cape Province is known to be one of the most preferred areas for the generation of solar energy in South Africa and even in the world. This can be ascribed to the advantageous sun radiation specifications and the vast flat planes that the province has to offer which are not intensively used except for grazing. The global irradiation in the specific area is between 2400 and 2600 kWh/m². Furthermore, specific parts of the Northern Cape can be used for the generation of power without compromising on food security due to the area’s low food produce capacity per hectare of usable land. Below is a map which gives an overview of this potential.

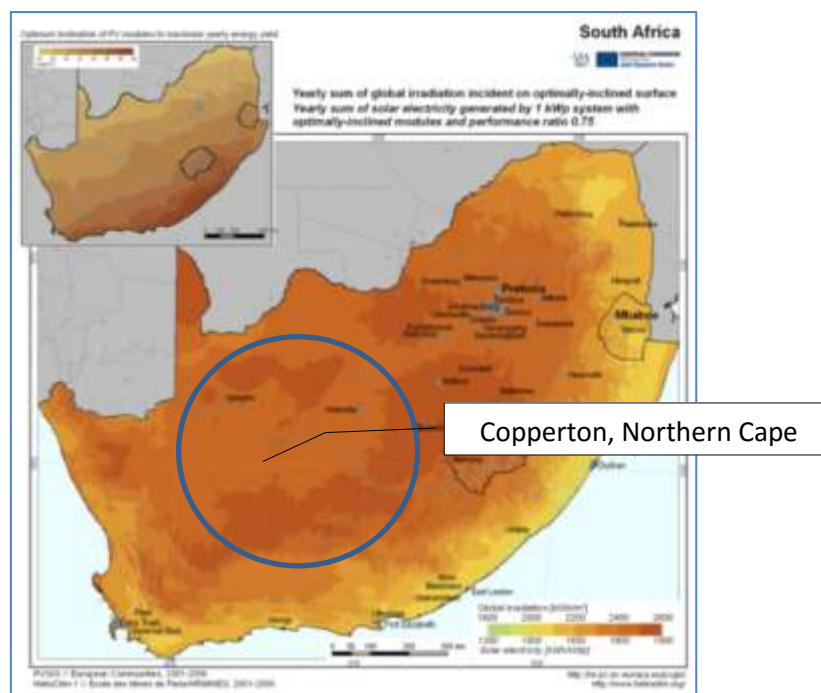

Figure 1: South African solar irradiation distribution

The benefits that the production of energy from the sun holds within the broader South African context outweigh most potential negative impacts the development may have on the bio-physical environment of the property. The contribution and agricultural value of the specific farm should be compared to the impact the national energy crisis could have. This crisis effects job creation, skills development and economic growth potential of the renewable industry.

On the economic front, the proposed project has the potential of making a significantly positive contribution to the local economy. The Northern Cape was well-known for the large number of copper and zinc mines in the area, but since the early 1990s, many of these mines have closed down, leaving a devastating trail of unemployment behind. The local economy, mainly supported by farming, is simply not enough to accommodate the high level of unemployment. In addition, social problems imposed by poverty create a problem in the surrounding area. The proposed development has the opportunity to create a significant amount of career opportunities over its entire lifespan of 20-30 years.

1.3 Overview of the proposed project

The applicant is proposing the establishment of a commercial solar energy facility, known as the Humansrus Solar 4 (Pty) Ltd. and will be operated under the licence of a company bearing the same name, Humansrus Solar 4 (Pty) Ltd. The proposed development site is located on the Farm 147, Humansrus, which is situated within the jurisdiction of the Siyathemba local Municipality in the Northern Cape Province. The purpose of the facility is to assist the government in providing much needed electricity by generating energy from the sun as renewable energy source. The proposed solar development aligns with the planned generation development by the Department of Energy, under the REIPPP program and the IRP 2010 plans.

The proposed facility is planned and designed for the generation of approximately 75 MW, although the actual MW_{peak} installed can be expected to be more in order to produce $75MW_p$. The developed electricity of this project will be fed into the national electricity grid. The proposed development site covers an area of approximately 270 hectares, although an initial preliminary study site of 448ha been selected for consideration by participating specialists.

2 Solar energy as a power generation technology

2.1 Basic understanding of solar PV plants

Photovoltaic (PV) modules convert the energy delivered by the sun to “Direct Current” (DC) electric energy. The array of modules is connected to an inverter by means of a network of cables. The DC power is inverted to “Alternating Current” (AC) power by a grid-tied inverter. The AC power can then be added to the national electricity network (grid). The voltage at which power is generated is increased/stepped up to the required voltage and frequency of the national grid by using a transformer. The electricity is distributed from the on-site transformers via distribution lines to the nearest ESKOM substation. From the ESKOM substation the electricity is fed into the ESKOM grid. Figure 2 depicts an overview of a typical solar PV facility and some its main infrastructure components.

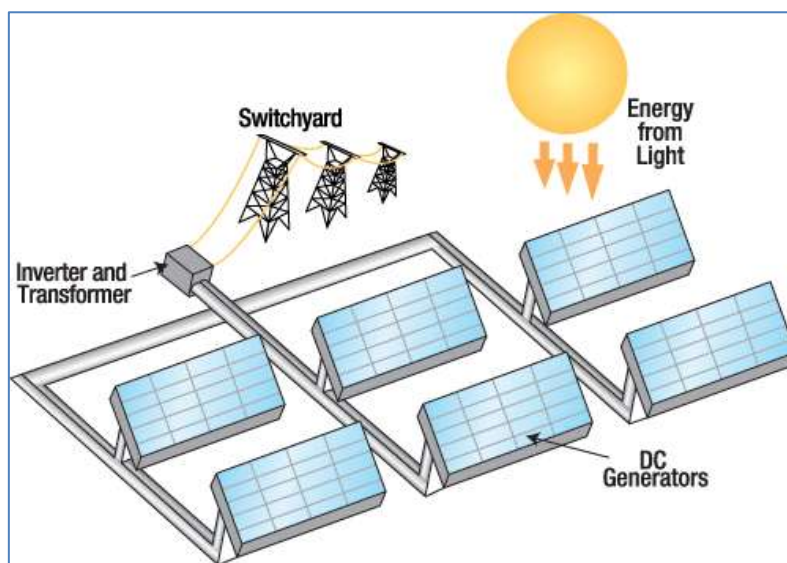

Figure 2: Typical solar PV plant diagram

The infrastructure of the facility includes the ground-mounted structures, solar modules, cables, inverter rooms, access roads, auxiliary roads, auxiliary buildings (administration, security, workshop, storage and ablution), water tanks, perimeter fencing with associated security infrastructure, an on-site substation, and electrical distribution line.

The primary input of the system is sunlight, which is converted to electricity. In the case of sun tracker technology the facility may also utilise auxiliary electricity from the ESKOM grid to power tracker motors in order to optimise the amount of sunlight on the solar PV infrastructure. In addition to auxiliary power being used for powering tracker motors, small amounts of auxiliary power would be used for on-site usage on items such as, but not limited to, security and site office energy requirements.

Installing either a fixed or dual tracking PV system (CPV modules or arrays of PV modules) is proposed. In a fixed system, the PV modules stay in one position, and do not follow the path of the sun. A tracking system is ground-mounted and follows the path of the sun with the use of typically single or dual-axis technology in order to maximise the amount of direct sunlight on the Solar PV modules. By following the sun, the tracked array production increase to full power and stays on maximum production for a longer time on a clear sunny day, while the fixed array only maintains maximum power for a few hours in the middle of the day.

2.2 Project-related benefits

The single largest benefit of the generation of solar energy is the fact that the electricity is generated by means of a renewable source, the sun. This contributes toward sustainability and renewable energy. In essence the energy source cannot become depleted as in the case with fossil fuels (i.e. coal or oil). This type of energy production does not pollute the environment – it is renewable, reliable and does not consume anything close to the amount of natural resources as compared to conventional power generation (e.g. coal power plants). Its long-term environmental benefits are perhaps the most notable of any electricity source. These benefits hold much promise for reducing environmental impacts from electricity production of coal power plants – which is the most common technology used in South Africa.

The production of 75 MWp alternative energy is a welcomed supplement to the electricity supply of South Africa and aligns with the targets set by government for reduction of fossil fuel reliance and fossil fuel based electricity and the corresponding reliance on fossil fuel.

The renewable energy projects are treated as “Strategically Important Developments” (SID’s) under the IPP Procurement Programmes, since these projects have the potential to make a significant contribution to the national and local economy.

Not only will the project contribute to the existing electricity grid of ESKOM in the area, but also contribute to the overall achieving of 40% share of new power generation being produced by IPPs nationally (as outlined within the “Integrated Resource Plan”, IRP 2010).

Long-term benefits, particularly related to the local community and society, can be realised through the project, mainly in terms of much needed employment and skills development. Such a project is a very good stimulus for the local and national economy, positively contributing especially to the surrounding community. In addition, the general requirements provided for by government stipulate strong local procurements and local investments into the surrounding communities.

3 Description of the proposed solar facility

The proposed Humansrus Solar 4 PV facility has a planned peak capacity of be 75 MW_p with an estimated development footprint of approximately 270ha and a development layout of approximately 220ha. Humansrus Solar 4 is the fourth planned solar energy facility developed on this particular farm Humansrus 147. The preliminary study area of 448ha has been assessed as part of the preliminary study area of the Humansrus Solar PV Energy Facility 2. The study area of 448ha is included within the environmental specialists study area.

The development footprint considered within the EIA is larger than what is physically required for the proposed development, so as to ensure ample development space are available after potential environmental sensitive areas are excluded, as a function of specialist studies and recommendations. The estimated portion of land each component of the facility will typically occupy is summarised in Table 2. The information within this table is based on an average development layout area of approximately 200-220ha for 75MW solar energy facility.

Table 2: Component size and percentage for the proposed 75MW_p

Component	Estimated extent of 75 MW plant	Percentage of development layout (\pm 200-220 ha)	Percentage of whole farm (\pm 4769.41 ha)
PV or CPV modules	175 ha (1.75 km ²)	87.5%	3.6%
Internal roads-6m width	18 ha (0.27 km ²)	9%	0.37%
Auxiliary buildings and laydown area	7 ha (0.07 km ²)	3.5%	less than 0.15%

The proposed infrastructures that are planned to be constructed include a series of solar PV modules (either constructed in conventional PV arrays or as loose standing CPV modules –both referred to as PV technology), inverters, internal electrical reticulation and an internal road network. An on-site substation will need to be constructed - this will typically include a transformer to allow the generated power to be connected to ESKOM's electricity grid. Auxiliary buildings including site office, control room, security office, ablution, workshops, storage areas and fencing, are planned to be erected. A distribution line will also be required to distribute the generated electricity from the site to the existing power lines and/or ESKOM substation.

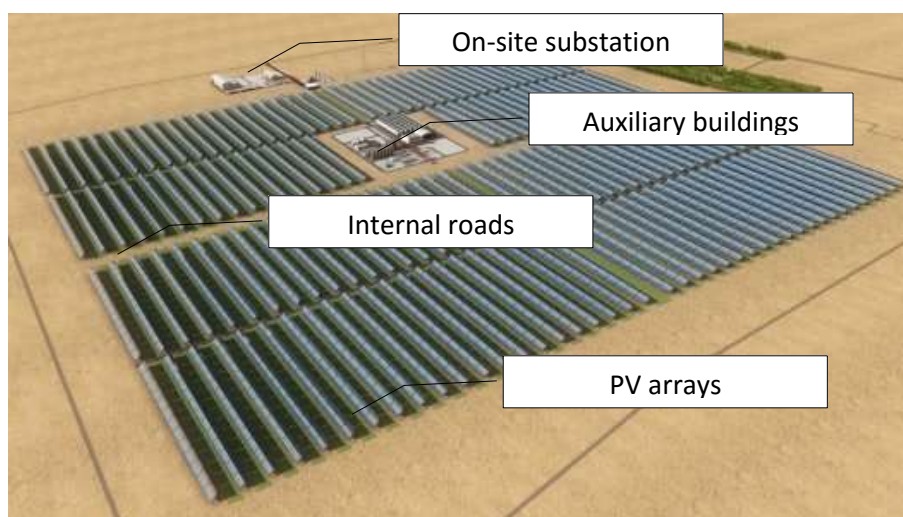

Figure 3: A typical layout of a solar PV plant

3.1 Site development components

The final preliminary design will consist of different components. A typical description of the components and their assumed impact are listed below. For more detail on the preliminary layout, please refer to the Layout Report. (Draft Impact Layout Report Solek - March 2016).

3.1.1 Position of solar facilities

The exact position of the solar PV or CPV module layout will follow a risk-averse approach and be determined by the recommendations in the environmental specialists' reports in order to avoid all sensitive areas in the positioning of the facility. In addition, the final facility layout will be influenced by the final detail design of the project once a tender has been awarded (once "preferred bidder" status has been awarded by the Department of Energy to the project).

The footprint of the 75 MW is located on a proposed preferred site layout area of 270 ha, with a preliminary investigated area of 448ha by specialists (Farm 147, Humansrus). The final facility footprint is 270ha with a development layout of 220ha. As per specialist studies no sensitive and exclusion areas have been defined within the preferred site. The following figure depicts a typical layout of PV modules for the two types of PV technology.



Figure 4: Typical PV module layout (PV and CSP)

3.1.2 Foundation footprint

The physical footprint of the PV/CPV modules on the ground is formed by a network of vertical poles (typically 100 mm in diameter), on which the modules are to be mounted. The following figure depicts the typical foundation and substructures unto which the frames and PV modules are mounted.



Figure 5: Foundation footprint

Different methods are used to mount the modules to the ground. The mounting structure choice will be influenced by the pricing, geotechnical properties and technology at the time of construction. Some of the methods include basic drilling or hammering with specific tools. The physical process of ramming the anchors into the ground is done using special equipment (typically self-powered vehicles on tracks).

In the case where earth screws or rock anchors would be more suitable, the rammed pole technology would be replaced by one of the former. Some of the ground covering in the medium sensitivity area will be cleared to do the frame installation accurately. Although the site is very flat, some minor excavation may be necessary in certain medium sensitivity areas.

Additionally modules can be mounted to the ground by casting small concrete foundation blocks; usage of concrete foundation will be limited as far as possible (function of geology and other requirements). Removal of such foundations is possible upon de-commissioning of the project.

3.1.3 Module height

The fix tilt (static) PV module arrays have an approximate height of 3.5 m, where single axis tracking module arrays will have an estimated height of 2.7m, whereas the CPV modules have a maximum height of 10m.

A maximum height of 10 m will be considered and assessed in the Environmental Impact Assessment Process. This will allow for a greater flexibility in terms of the type of technology to be used and effectively allow the facility to cater for improvements of technology types and industry as a whole. The maximum height listed here is only a precautionary description due to foreseeable future changes in technology.

3.1.4 Solar Module Area

The solar arrays are put together with strings of solar modules connected in series, which can be mounted onto fixed, single or double axis tracking systems. These frames are typically installed with the single axis tracking frames which are typically installed in a north-south direction in order to maximise the output of the system.

The standardised length of a solar array would typically be between 50m and 200m in length. Where a tracker system is used, modules are controlled and standardised systems are preferred for economic and practical reasons. The solar modules will be placed in such a way that it would have the least influence on the natural seasonal washes and avoiding the ecological boundaries set where required and practically possible.

3.1.5 Access road to site

An access road of approximately 6m wide will be required for the facility. The access road alternatives are discussed in more detail later in this report and within the Layout Report.

3.1.6 Internal roads indication width

Gravelled internal roads and un-surfaced access tracks are to be provided for. Such access tracks (typically < 6 m wide and limited to the construction site) will form part of the development footprint. Pathways (typically <4 m wide) between the PV/CPV module layout will typically also be provided for to make the cleaning and maintenance of the modules possible. Existing roads will be used as far as possible.

The following figure depicts an example of typical internal roads.



Figure 6: Typical internal road example

3.1.7 Inverter Rooms

The DC cabling (LV/MV) from the module strings will be connected to the inverters that will be housed within inverter rooms located at specific areas. The location of these areas will be illustrated and stipulated within the solar PV design layouts and cabling diagrams (these diagrams will be populated once detailed design is finalised, typically after preferred bidder status is obtained). The footprint of an inverter room will be approximately 56m² (4m x 14m) and height of 3m.



Figure 7: Typical inverter room

3.1.8 On-site substations and transformers

The step-up substation and its associated infrastructure and internal roads might have a footprint of approximately 1 ha, including a switching station, IPP transformer, IPP HV yard, Eskom HV yard, switch gear and feeder bays.



Figure 8: Typical on-site substation footprint

3.1.9 Cable routes and trench dimensions

Shallow trenches for electric cables might be required to connect the PV/CPV modules to the inverter rooms and the inverter rooms to the on-site substation. These electric cables are planned along internal roads and/or along pathways between the PV/CPV modules as far as possible.



Figure 9: Typical cable trenches.

3.1.10 Connection routes to the distribution/transmission network

Electricity will be transmitted from the on-site step-up substation via a new self-build overhead power line to the Kronos ESKOM substation. Due to the planned decommissioning of the Cuprum Hydra 132kV powerline a Loop-in Loop-out grid connection option has been eliminated from the grid connection options. The final preferred route will be subject to the negotiations with the neighbouring farmers and the recommendation of the environmental specialists. Please refer to the Layout Report (Solek March 2016) for more detailed depiction and description of grid connection route options.

3.1.11 Security fence

A perimeter security fence will be constructed around the solar park with a guarded security point. The perimeter security fence is envisioned to include security cameras and any related and required infrastructure (such as cabling, central monitoring, electricity supply etc.). Note that energy supply towards this required security infrastructure is envisioned to be obtained from the auxiliary power supply. The perimeter fencing will be done as per recommendations from environmental specialists and in such a way that small animals could freely access and escape solar facility area on the farmland as and where required.

3.1.12 Cut and fill areas

As far as possible, any cut and fill activity along the access roads will be avoided. Where alternations might be necessary, input from civil construction engineers will be sourced regarding the cut and fill aspects.

3.1.13 Borrow pits

As far as possible, the creation of borrow pits will be avoided. There is a quarry site located on the existing Humansrus farm 147. The road surfacing material required (e.g. gravel/base course or stone) can be sourced from these existing quarries on the farm should additional road surfacing material be required. The current EIA application does not make provision for new borrow pits. Should new borrow pits be required on the property, these will have to be licenced/authorised in terms of the Minerals and Petroleum Resources Development Act and the National Environmental Management Act. To avoid this process an existing licenced borrow pit in the area would rather be used.

3.1.14 Soil heaps

As far as possible, the creation of permanent soil heaps will be avoided. All topsoil removed for the purpose of digging foundations are to be separately stockpiled within the boundaries of the 270ha development footprint, for later rehabilitation. The stockpiled topsoil should be covered so as to ensure that minimum quantities are lost due to wind and rain erosion. It is unlikely that major soil heaps will be required for this construction site.

3.1.15 Auxiliary buildings area

Auxiliary buildings with a total typical footprint of approximately 1000-1300m², includes the following:

- Control Building (including offices, +/- 250m²);
- Warehouses and workshop (+/-200m²)
- Canteen & Visitors Centre (+/- 300m²)
- Staff Lockers & Ablution (250m²); and
- Gate house / security offices (+/- 200m²),

Additionally to the noted auxiliary building footprint a parking area of typically 300m² is allowed for. The site offices (management and administrative), control rooms, workshop and warehouse buildings, ablution, cafeteria and parking area will in total will utilise a footprint area of approximately 1000-1300m². The workshop will be used for general maintenance of parts, etc. and will typically be 100m² m. The warehouse will be used for the storage of small equipment and parts and will typically be 100 m². The change and ablution facilities will be very basic and will include toilets, basins and a change area with an area of approximately 250m². The management and administrative and offices will be used as an on-site offices and will have a footprint of typically 250m². The cafeteria and kitchen area will have an estimated footprint 300m².

The final detailed design and exact coordinated layout of the facility will be designed and finalised should the facility be approved and awarded a tender as a “preferred bidder” under the REIPPP. The component list above is typical to such projects and may deviate due to engineering requirements, new technologies and regulatory changes from the government’s tender process. This will be done should the project be approved and the environmental specialists recommendations have been made.

3.1.16 Fuel storage

The above ground storage of fuel is planned to be located within the “camp site” or nearby the site office and auxiliary buildings. The amount of fuel which will be stored on-site during the construction period as well as the operation period will be well below the 30m³ threshold as stipulated by NEMA (amended 2006).

Mobile fuel units could be used, but will be refuelled at the on-site fuel storage (located within the “camp site”). The storage of fuel will not be close to water sources and all best practises should be adhered to in order to prevent spillage and contamination of any water sources. Additional best practises will be used such as automatic shut-off nozzles, drip pans and regular maintenance of all fuel related infrastructure.

3.1.17 Fire management and protection area

It is of importance that cognisance of fire risks should be taken and the corresponding preventative matters be implemented. It is the landowner's responsibility to maintain firebreaks on the border of his property, which also includes the border of the long-term lease area. The solar facility has a similar responsibility to maintain an adequate fire break on its own border.

Additional preparation should be taken by both the landowner and the solar facility (and its personnel) to be sufficiently prepared in combatting veld fires. The management of plant biomass within the solar facility boundaries are important as there could be an increase of such biomass should the area experience exceptional heavy rains in previous years. The solar facility should actively manage such a potential build-up of biomass within its area so as to reduce any fire risk.

Additional cognisance, planning and execution of the following key points should be taken in operating the solar facility: Fires should only be allowed within fire-safe demarcated areas (within the site camp and not within the solar field itself); contact details should be available on site of local fire and emergency services; basic firefighting equipment should be available on-site; adequate training should be given to personnel in fire prevention and fighting; all contractors and employees should be briefed on the management of fire and prevention thereof on-site.

3.1.18 Laydown area

An appropriate laydown area is planned for to reduce the environmental impacts of the project during its construction phase. The laydown area will be an open area within the facility fenced off area where modules, frames and material will be stored and staged during the facility construction and assembly phase. The laydown area could be an area of approximately 5ha.

3.2 Project alternatives

In order to propose the best possible design in terms of economic, practical and environmental aspects, several alternatives have been considered. The various alternatives considered in terms of site, layout, technology, and distribution lines are discussed in the following sections.

3.2.1 Site alternatives

Humansrus Solar 4 is the fourth proposed project development on the farm Humansrus 147. Two site alternatives are being investigated and are referred to as the "Preferred and Alternative layouts".

3.2.2 Layout alternatives

Determining the optimal and detailed layout is a costly process which would normally take place once preferred bidder status has been awarded to the project. Two layout alternatives have been considered, taking into account the assessment of the preliminary study area of the Humansrus Solar PV Energy Facility 2 and its specialist studies. It should be noted that the Humansrus Solar PV Energy Facility 2 received environmental authorization. The preferred and alternative layouts will taking into account the site constraints identified and recommendations made by the various EIA specialists (within the environmental impact assessment phase). The actual location of the different facility components on the proposed development site may vary.

3.2.3 Technology alternatives

The proposed development area will make use of Solar PV or Solar CPV technology. The option of constructing a CSP facility is not considered or assessed within this application.

These two PV technology alternatives (Solar PV and Concentrated PV) are both considered for this application. An overview of the two PV technologies as well as a summary of their advantages and disadvantages is discussed in the following section below.

3.2.3.1 PV alternative T1: concentrated photovoltaic solar farm (CPV)

CPV technology differs from conventional photovoltaic systems (PV) in that the CPV modules use different solar cells and include lenses which focus light energy in a more concentrated manner, hence harvesting more energy from the sun within a smaller area. The efficiency of the cells provides benefits relating to capacity per module and reduced spatial requirements and usage. CPV technology systems are much taller than conventional PV technology, with the system reaching a maximum height of approximately 10 m. In some cases CPV installations can require a larger amount of water for cooling purposes, unlike PV modules which only require water for cleaning purposes. However, there are alternative dry cooling methods that do not require additional water.

By using CPV technology the impact on the environment can be seen as slightly higher mostly in terms of the increased height of the module, although some parties see this as an environmental advantage. The height of the modules and the fact that the modules are spread wider apart exposed the ground below the modules to more sunlight than conventional PV arrays, which can allow the vegetation to grow back much quicker than with conventional PV facilities.

PV Alternative T2: Photovoltaic Solar Farm (PV) – the preferred and proposed alternative

Photovoltaic solar power is solar energy that is converted into electricity using photovoltaic solar cells. The captured light moves along a circuit from positive-type semiconductors to negative-type semiconductors in order to create electric voltage. Semiconductors only conduct electricity when exposed to light, as opposed to conductors, which always conduct electricity, and insulators, which never conduct electricity.



Power is collected through a structure comprised of many solar cells, usually a solar power panel (also called a PV module). PV modules/solar panels can be combined into an “array” of modules in order to capture a greater amount of solar energy. PV solar modules can either be fixed (rows of tables) or they can be constructed on a single or double axis tracking system. Tracking systems will use sun sensors to follow the movements of the sun, combined with mechanical movement the array of solar modules follow the sun for increased production. With the double axis tracking system the sun can be tracked on more than one axis allowing the maximum radiation over the entire solar module for the maximum exposure time throughout the day and the year.

The fixed tilt solar technology (table installations of rows) is the less expensive option but it has a much lower energy yield than the axis tracking system (single or double axis tracking). Single axis trackers are typically more economically feasible than dual axis trackers, although single axis tracking infrastructure produces less yield than dual axis tracking per annum. Single axis trackers typically yields more than fixed tilt static frame installations.

3.2.3.2 Summary of environmental advantages and disadvantages of CPV and PV technology

Table 3 depicts the different advantages and disadvantages related to the two types of photovoltaic technology, described here as PV and CPV technology.

Table 3: Technology comparisson (CPV and PV) - advantages and disadvantages

	CPV	PV
		
<i>Advantages</i>	<ul style="list-style-type: none"> • Takes up less surface area therefore “footprint” is less, resulting in less impact on soil, agriculture and biodiversity. • More energy can be produced per module. • Because the modules are taller and has a greater separation distance, the ground in between and under the modules are exposed to more sunlight, allowing vegetation to grow back easier after construction. 	<ul style="list-style-type: none"> • Lower visual impact (range between 2 m and 5 m in height). • Lower impact on birds due to lower height. • Lower impact on bats due to lower height. • Easier to erect PV technology. • Lower impact on heritage/ culture due to lower impact on landscape of visual impacts. • Easier to transport.
<i>Disadvantages</i>	<ul style="list-style-type: none"> • Higher visual impact, CPV systems can be up to 10 m high. • Higher impact on birds. • Higher impact on bats. • Requires skilled labour because more the structures are more difficult to erect. • CPV systems typically utilises more water than conventional PV. • Higher cultural/ historic impact to the landscape. • Harder to transport – abnormal load. 	<ul style="list-style-type: none"> • PV facilities of the same footprint of CPV facilities produce less power. • The tightly packed PV arrays allow little sunlight through, which can cause the vegetation to grow back slower.

The industry is changing very quickly in terms of PV technology types and associated costs. Constraining the project to a particular technology at this stage could be detrimental towards the viability of the project in the light of what will be realistic to construct in 2-3 years from now. Due to the fact that the impact on the environment of the two PV technologies is more or less the same, it is requested that the EIA allow for either one of these alternatives.

3.2.4 Mounting and film alternatives

PV solar power technology has been identified as the preferred technology to generate electricity in this project. There are, however, several alternatives in terms of the specific solar PV technology to be used. These alternatives can be grouped in terms of mounting and film alternatives but should not trigger any major difference in the impact of the project as explained in this report.

3.2.4.1 Mounting alternatives

There are two major alternatives in terms of solar PV mounting, namely fixed-tilt and tracker mounting technology. The following figure depicts the two mounting alternatives.

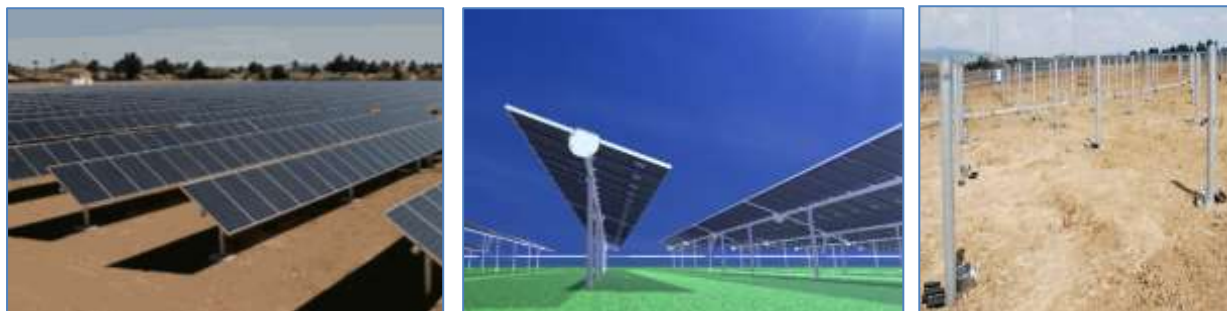

Figure 10: PV mounting structures scenarios

When fixed-tilt solar mounting technology is considered, the solar PV modules are fixed to the ground and do not contain any moving parts. These modules are fixed at a specific north facing angle. This type of technology is less expensive than tracker technology, but it has a lower energy yield due to the limited exposure to sun radiation.

The preferred technology type is known as horizontal tracker technology. This technology is designed to follow the path of the sun across the sky. By using this technology, the modules are exposed to typically 25% more radiation than fixed systems. The design is extremely robust and contains only a few moving parts. It also has more or less the same footprint and infrastructure requirements than that of fixed-tilt designs. The tracker requires approximately 1.8 to 2.3 hectares per megawatt. The tracking design is based on a simple design and makes use of a well proven off-the-shelf technology that is readily available. If conventional PV modules are used, the maximum height of the trackers is typically less than 2.7 m, but as previously stated, the CPV trackers are much higher, reaching a maximum height of approximately 10 m. The modules will most probably be mounted on either a single axis or a dual axis tracking system, both of which have a similar impact. However, because of unforeseeable changes in technology, it is requested that flexibility be granted in this regard in the EA.

The foundation of mountings can either be laid in a small concrete block, driven piers or a deep seated screw mounting system. The impact on agricultural resources and production of these alternatives are considered equal, although the concrete option will require greater inputs during decommissioning in order to remove the concrete from the soil. Driven piers and deep seated screws are recommended in order to minimise the environmental impact and input during decommissioning of the facility, but will be dependent on mechanical specifications as well as the geotechnical qualities and corresponding constraints.

If concrete foundations are used, foundation holes will be mechanically excavated to a depth of about 40 cm – 60 cm. The concrete foundation will be poured and be left for up to a week to cure.

Additional geotechnical investigation is expected to be done during the detail design phase which will assist in determining the feasibility of each technology option and influence the detailed design. The mounting structure choice will also be influenced by the technology advancement and pricing and should not be specifically indicated. It is requested that the EA allow for either one of these alternatives.

3.2.4.2 Film Alternatives

There are a multitude of different film technologies available within the market. The best solution, according to research conducted, are either thin film (amorphous silicon or cadmium telluride) or - crystalline cells (mono- or poly-crystalline) depending on the space and irradiance of local conditions.

As mentioned earlier, the film type do not affect the layout and impact from an environmental perspective and would not affect the environmental impact of the proposed project. Due to the industry changing very quickly in terms of costing of the different film types it is requested that the EA allow for either one of the alternatives.

3.2.5 The “do-nothing” alternative

This Farm 147 Humansrus is currently used for limited stock grazing. The exclusion of approximately 270 ha development footprint from the 4769.41 ha property for the purposes of the solar facility will not have a significant effect on these farming activities.

The associated project impacts on the agricultural resources (soil and water) are expected to minimal. Should the do-nothing alternative be considered, the positive impacts associated with the solar facility (increased revenue for the farmer, local employment and generation of electricity from a renewable resource) will not be realised.

Cape EAPrac, the environmental assessment practitioners for this project reports within its investigation on the environmental impact should the development of the proposed facility not take place.

3.3 Access to facility

Access to the site will be along appropriate national, provincial and local roads. The access roads to the site will be from the R357 Van Wyksvlei road. Different access routes have been investigated which could be used as access to the facility. The following figure depicts the different access route options and route alternatives.

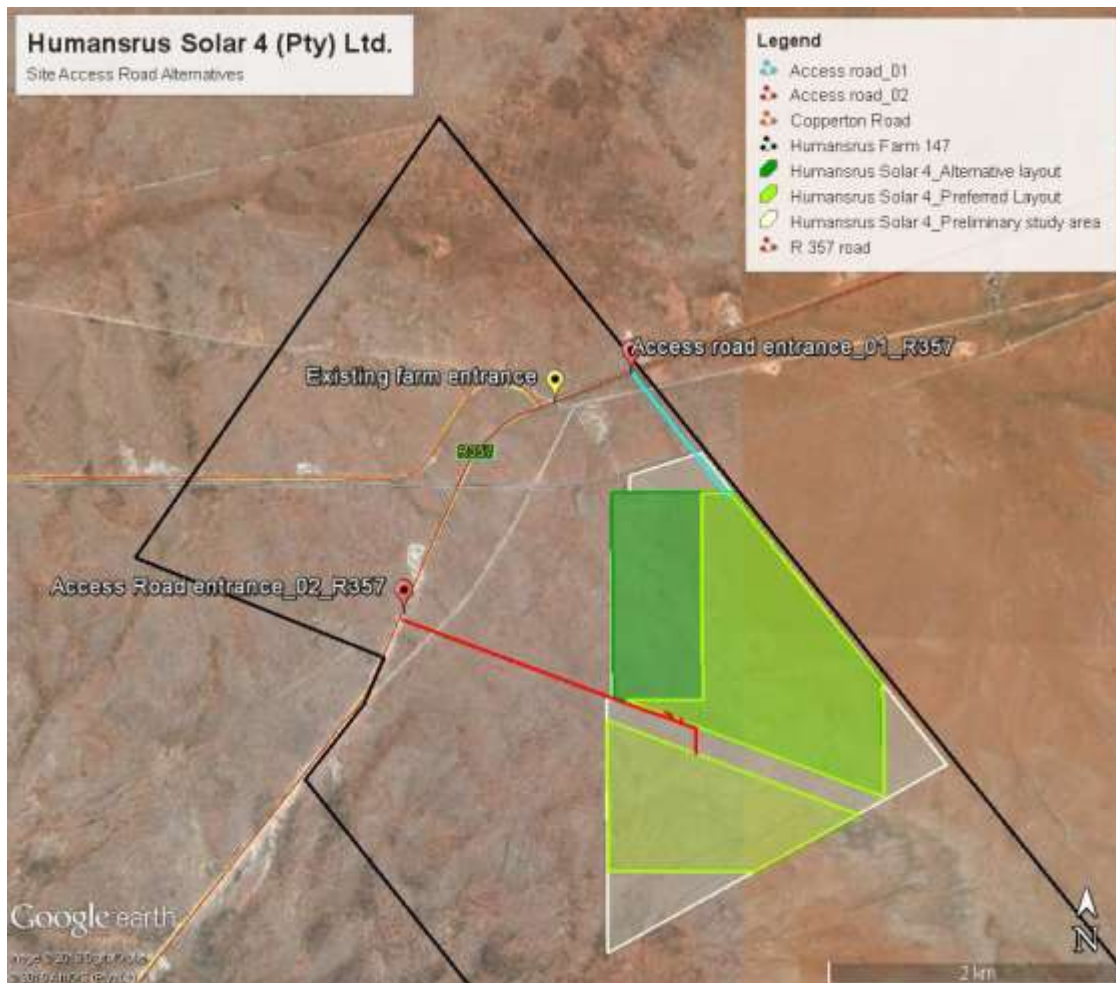

Figure 11: Access road alternatives for the proposed site

The proposed site can be accessed from the R357 Van Wyksvlei road west of the proposed site. There are two access road alternatives, with two possible entrances, that are being investigated to determine which one will have the least environmental impact and would be more viable.

Detailed discussions to the access roads and the corresponding entrances are discussed and depicted within the layout report in Section 3.1 of the Humansrus Solar 4 Layout Report. Note that all access roads and internal roads will have a width of less than eight meters (<8m). In addition detailed planning of access roads will be included within the final design of the facility.

As part of the Environmental Impact assessment the access road alternatives have been discussed with the provincial road department and an approval letter were received for the alternative site entrance access roads from the R357 road. It should be noted that specific road corridors for the landowner is allowed for in order to maintain open access to the farmland for its owner.

Due to the location of the planned onsite substation and auxiliary buildings, the proposed “Access road entrance_02_R357” is the preferred site access road to the facility.

3.4 Water related items

The following portion of the report are dedicated to discussions pertaining to water, the volumes and seasonality of the project requirements, the sources available, the infrastructure pertaining to water usage, the legislative approvals required for water usage and the corresponding environmental impact risks thereof.

3.4.1 Water requirements

The project consumes water for two purposes, the first being during the construction period and the second being for maintenance purposes (during the operational phase). The construction of the solar facility requires approximately 300-500 m³/month during the construction period (5400m³ – 6000m³/12-18month construction period). The project requires about 10 litres of water per module per annum for the purposes of maintaining proper production (water used for cleaning of modules).

The amount and size of the modules that will be used will therefore determine how much water will be required for the maintenance requirements of a 75 MW plant. If a 350 Watt module is used, a 75 MW plant (installed 85MW) will consist of more or less 245 000 modules, which will roughly calculate to 6.6-8 kl of water required per day (2'400-2'900 m³/annum), when considering an average consumption throughout the year.

The 20 x 10 kl capacity water tanks will be places on site in order to store 200 000 litres (200m³) of water at any given time, effectively providing a storage capacity of two to four weeks of cleaning water supply. The proposed activity is not a “water intensive activity” (as opposed to CSP technology).

Only a limited amount of water is required in low rainfall periods to clean the modules once every quarter so that they can operate at maximum capacity. No chemicals will be used to clean the modules. Weather conditions, traffic and general dustiness at the site play a role in the exact amount of water required to clean the solar PV modules. At present it is assumed that each module should be washed once every three months.

To further reduce the use of water at the solar facility, the use of alternative module cleaning methods is also being investigated. The most feasible technology under consideration uses compressed air to blow off any debris and dust from the module surface. At this stage the technology is being tested and needs refinement before it would be commercially viable. Other cleaning options are currently under development where rotating rubber-based waterless cleaning is used. Cleaning technologies are improving overtime and it is expected that more innovative cleaning technology will be developed, further reducing or eliminating water requirements although these are not fully commercially proven.

A preliminary water use licence application has been submitted and will only be processed after preferred bidder status and when confirmed by specialist requirements. A water use licence is expected to be required for any water extraction (boreholes, rivers or channels) or for crossing river beds/washes. As far as possible, it is planned to avoid engaging in activities or actions which requires a water use licence, for example the crossing of perennial washes or abstraction of water. From ecology and freshwater specialist studies no exclusion (sensitive) water areas (seasonal washes) has been identified.

3.4.2 Water sources

There are a number of different water sources which can be further investigated to supply water for the project. The following section investigates these options.

3.4.2.1 Boreholes:

The preferred water sources are the existing boreholes on the proposed farm. Two boreholes have been identified on the farm, situated near the proposed site. These boreholes are seen as a possible water option for the facility.

A full pump-test is expected to be done after preferred-bidder status, should borehole water supply remain the preferred water supply, in order to confirm sufficient water supply potential from on-site boreholes; this will further confirm water availability.

The water from boreholes could be pumped to the on-site water tanks through a pipeline, although this will depend on the final location of the water tanks. Should such a water pipeline be required, the pipe diameter will be approximately 50mm-100mm. The pipeline will be laid on the ground, or just below the ground by means of manual excavation. The water pipeline should not result in any additional environmental impacts outside of the main construction area.

The utilisation of water from the boreholes is likely to require a licence in terms of section 21 (a) of the National Water Act which regulates abstraction from a water source. Should it deem possible to avoid the need for a water licence it would be done (for example eliminating water abstraction on-site as an option). A proof of submission of a "Water use licence application" (WULA) will be included within the Final Environmental Impact report might a water use licence be required.

Note that a freshwater and ecology study have been done as to verify any constraints surrounding seasonal washes and to take cognisance of any water use licence activities which could be required and will be included within the impact assessment phase. The outcome of the studies indicated that the proposed solar energy facility have negligible impact on the aquatic environment. No alluvial water courses been identified within the preliminary study site.

3.4.2.2 Prieska-Copperton water-pipeline

As an additional option to obtain water from the existing pipeline which supplies Copperton and Alkantpan with potable water, an approval letter has been received from Alkantpan regarding the availability and use of water. The water is currently being fed, via the constructed pipeline, from Prieska and the Orange River. Should water be drawn from the existing water-pipeline, water will most probably transported with water trucks.

The usage of this "Alkantpan" potable water could potentially avoid the requirement of obtaining a water use licence from the Department of Water Affairs in terms of the extraction of water from resources such as groundwater or rivers (Section 21 (a)).

Permission to obtain water from the Alkantpan pipeline was obtained from Siyathemba local municipality and from Alkantpan facility. In principle it was therefore approved by all parties involved that Humansrus Solar 4 (Pty) Ltd. can make use of water from the said pipeline.

3.4.2.3 *Siyathemba local municipality (alternative supply)*

Permission to use water directly from the nearest town (Copperton) has been investigated. This water will also have to be transported by trucks to the proposed site. This will be seen as the last alternative as transport costs will be significantly higher compared to the other two options. The usage of municipal water can reduce the requirement of obtaining a water use licence from the Department of Water Affairs in terms of the extraction of water from resources such as groundwater or rivers.

3.4.2.4 *Rainwater*

As an additional measure, PVC rainwater tanks could be placed alongside the on-site buildings to collect the rainwater runoff from the roof. These PVC tanks will then form part of the water storage tanks.

3.4.3 **Water buffer**

Water storing infrastructure is to be provided as part of the auxiliary building footprint area. Storing capacity for two weeks are planned to be provided for. This will add up to twenty 10 kl water tanks.



Figure 12: Typical water storage tank

3.4.4 **Water-use permission**

A preliminary water use application has been submitted as part of the environmental impact assessment process and will only be processed after preferred bidder status and details to be completed as per requirements. As stated previously, proof of such a “Water use licence application” submission will be added to the “Final Environmental Impact Report”.

However, as also stipulated in the official REIPPP documentation (RFP, Volume 1, Part 1, Section 4.5) the “Department of Water and Sanitation” (DWS) will only process water use licence applications from developers who have been selected as Preferred Bidders. Therefore a full assessment of the water-use licence application will only be undertaken by the DWS once the project is approved.

The EIA application can therefore be submitted without a water licence, although application proof of receipt is required. The DWS are also registered as a key stakeholder in the environmental process and will have an opportunity to provide any additional input.

3.4.5 **Erosion and storm water control**

The risk of water erosion is low because of the extremely low annual rainfall in the area. The ground condition in the Copperton area is such that large portions of surface water are absorbed into the soil. This avoids water build up on the surface and quickly reduces any water flow which might cause water erosion.

On large structures or buildings appropriate guttering could be used around the building to avoid water erosion where roof water would be flowing off the roof. Wherever practically possible rainfall run-off from the roofs/gutters will be captured and stored in rainwater tanks. If this water cannot be captured, water will be channelled into energy dissipating structures to spread the water and slow it down to reduce the risk of erosion. Such a structure could be moulded from precast concrete, loosely packed rock or perforated bags filled with stone.

Any rainfall on the solar modules would be welcomed due to its cleaning effect, but as mentioned before the annual predicted rainfall is very low and would not cause any erosion worth discussing. The solar module surfaces are installed at a relatively large incline with gaps between modules.

This does not allow significant water build up on the modules while also reducing the energy in falling droplets. Should a tracking technology be used this implies that droplets leaving the solar module surface would not drop onto the same ground areas all the time.

No seasonal washes were identified within the preliminary study area. To avoid erosion recognised building practices will be followed to keep the natural flow of water within its natural borders. It is in the interest of the solar operator to keep the area clean and free of erosion to avoid any damage to the equipment. The solar modules would be installed on frames, allowing for natural water flow underneath the structure.

During the construction phase of the project there might be a risk of wind erosion where natural vegetation is removed. This might increase the risk of damaging sensitive equipment with a sandblasting effect and all parties involved will be vigilant to avoiding this from happening. A phased construction approach will be investigated

A phased construction approach should also minimise the amount of exposed soil at any one time thus reducing the risk for wind erosion and dust generation. Once the construction on each phase is complete the cleared areas is expected to be re-vegetated with locally-collected seed of indigenous species and left for vegetation to return to the area naturally. Bare areas are envisioned to be packed with brush removed from other parts of the site to encourage natural vegetation regeneration and limit erosion. Any water being used in the cleaning process would speed up this natural vegetation rehabilitation process. Further it will also have a bonding effect on the sandy soil, avoiding the loose sand blowing away causing wind erosion.



Figure 13: Illustration of current vegetation on the farm

Access roads and internal roads would also be designed and build using recognised erosion and storm water management systems. During the construction phase of the solar PV facility temporary solutions would be implemented to ensure that the environment is preserved in a sustainable way by avoiding erosion. The following figure shows a typical temporary solution that would be implemented during the construction phase, basically consisting of an inlet, channel and outlet. During outflow of the water energy is dissipated allowing any particles to sink to the ground which also avoids fast flowing water to sweep particles up from the ground avoiding erosion, by flowing though packed stones acting as a filter.



Figure 14: Installed concrete pipes and culverts

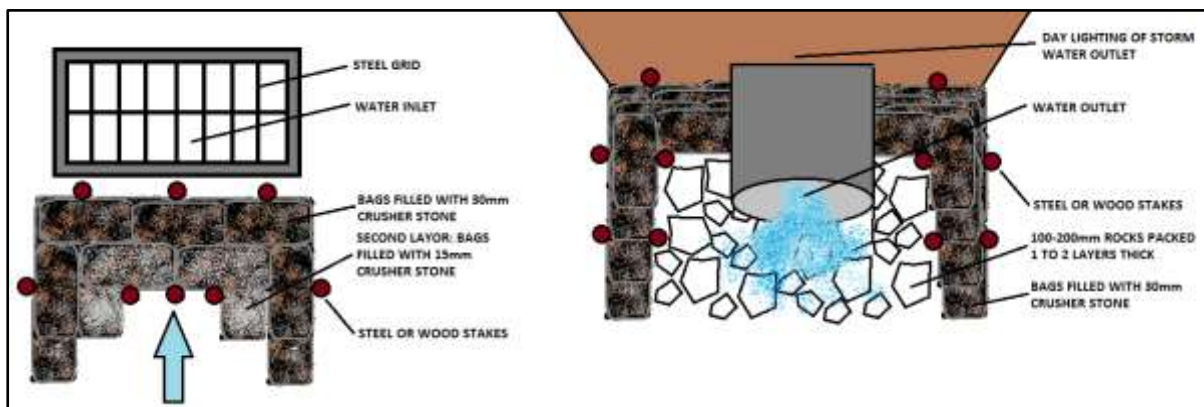

Figure 15: Temporary culvert inlet and outlet

More permanent solutions would be designed to keep storm water under control in a sustainable way. These structures would be built to be aesthetically pleasing by using fixtures such as stones packed in wire mesh to stay in a position or locking retaining walls at the inflow and outflow of the culverts also acting as scour protection.

Depending on the situation which is influenced by the type of water control most probably being stream crossing (in this particular case it would be a dry water wash for most of the year) or a culvert for water runoff management, either portal culverts with bases or reinforced precast concrete pipes would be used as the channelling.

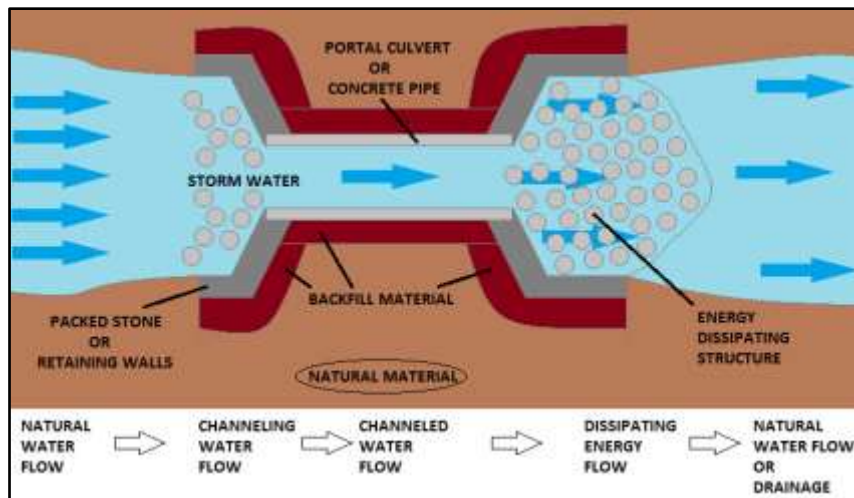

Figure 16: Storm water flow

An alternative to culverts considering drainage line crossings, Low-level River Crossings (LLRC) can be used. A LLRC is a structure that is designed in such a way to provide a bridge when water flow is low, while under high flow conditions water runs over the roadway, without causing damage.

Two types of LLRC can be used depending of the particular situation. A “Causeway” contains openings underneath the surface, which allows passing water through where a “Drift” does not.

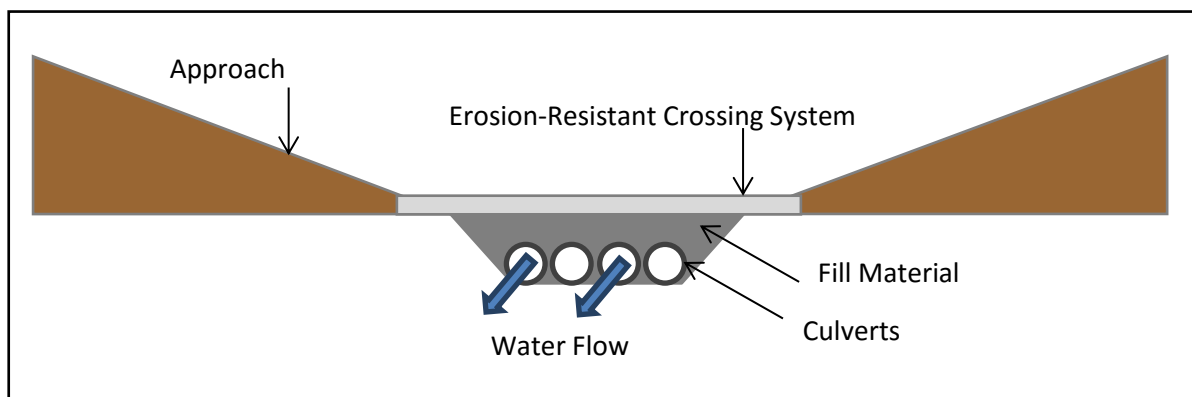

Figure 17: Causeway (Low Level River Crossing)

The same type of erosion control methods discussed with the culverts is taken into account when designing a LLRC. Because a LLRC is designed for water to flow over it, erosion protection is very important. Rock filled baskets, loosely packed rock or perforated bags filled with stone are some of the methods usually considered with LLRC.

The water use licence application process will only be required should water extraction on-site be required by means of a borehole. Due to the fact that no washes were identified by the surface water specialist the need for licencing of crossings of water courses in terms of Section 21(i) &(c) of the national water act will not be required. The third party water supply which was obtained reduces the need for on-site water extraction and as such reduces the need for a water use licence application.

There is however still a possibility that on-site water extraction becomes viable in which-case the extraction (Section 21a of the national water act) will be required. A water use licence application was submitted for Section 21 (a) should on-site water abstraction be required. This application process will only commence if the project is selected as a preferred bidder. It should be noted that the finalization of the detail facility layout design is typically done only after preferred bidder status is obtained. Note that these discussed erosion prevention and storm water management will be implemented as and where required (to be finalised and included within the final detailed facility design and considerations to be taken will be obtained from specialists within the impact phase of this project).

As part of the impact phase of the environmental assessment process, a Storm water management, Erosion and Wash-water report has been prepared.

3.5 Grid connection

In the scoping and impact phase a self-build powerline option has been investigated. Due to the planned decommissioning of the Cuprum Hydra 132kV powerline a Loop-in Loop-out grid connection option has been eliminated from the grid connection options. Due to the information available (January 2016) and ESKOM recommending connecting to Kronos substation a self-build Powerline option connecting to the ESKOM Kronos substation has been selected and will be assessed.

Please note that the self-build powerline from “Humansrus Solar 4_on-site sub-station_01” to Kronos Substation is seen as the preferred route. **Please note that a separate basic assessment process will be done with regard to grid connection.**

Self-build grid connection options erects new grid connection infrastructure from the on-site substation to the Kronos substation in order to evacuate the generated electricity.

The 132kV grid connections typically have a height of less than 25m and require servitude of 32m in width. The length of the grid connections differ depending on the route taken, although the preferred grid connection currently has a length of approximately seven kilometres for the self-build line from the on-site substation to the Kronos substation. The on-site substation will form the point of connection between the grid connections and the generation facility. Due to the cost associated with grid connection infrastructure, the shortest possible route would be chosen.

Various mounting structures can be considered for grid connections such as monopoles, lattice structures and a large variety of solutions. It is the opinion of Solek that the mounting structures should not be specified at this stage of the environmental impact due to advancements and changes within mounting structures possibilities. The proposed route was chosen along existing fences, parallel to the R 357 road and planned power line corridors, in order to minimise the additional environmental impact.

Humansrus Solar 4 (Pty) Ltd takes cognisance of the requirements set out by ESKOM to provide unobstructed access to all its servitudes. The use of explosives shall not occur closer than ESKOM's required 500m from ESKOM's infrastructure without prior written consent. Changes in ground level should not infringe on statutory ground level clearance requirements to ESKOM's satisfaction. Any work and usage of high lifting machinery will not take place close to ESKOM equipment without prior arrangement and approvals as required. ESKOM's servitude rights will be respected and all required approvals thereto will be obtained should this be required.

ESKOM requires all Solar PV projects within two kilometres from a substation to inform them as such in writing. Humansrus Solar 4 (Pty) Ltd. does not however fall within this stipulated two kilometre radius of the Kronos substation (or any other substation for that matter).

Please refer to the Humansrus Solar 4 layout report for a detailed depiction of the self-build powerline grid connection, its location and the corresponding on-site substation.

3.6 Services Required

Due to the remote location of the proposed site, making use of municipal services is very difficult. It is therefore proposed to manage the Water and Electricity, Sewage and Waste Removal aspects independently.

3.6.1 Water

Water might be sourced from either boreholes close to the proposed project site, the Siyathemba local municipality, the Alkantpan pipeline or other third party suppliers. Permission has been obtained from the farmer in the lease agreement, that the borehole water may be used. According to the farmer the water is drinking water quality. The water will be stored on site in standard 10kl water tanks. Due to the small amount of water needed, water can also be obtained from the Siyathemba local municipality and transported to the site by standard water trucks, should the borehole water not be utilised. Please see section 3.4 on water related items.

As stated previously, should an on-site borehole be used pump tests will be conducted after preferred bidder status is obtained.

3.6.2 Electricity

Electricity will be needed during the construction period as well as the operation period in the support offices, security systems etc. A newly constructed electrical supply point (11kV) was supplied on the Farm Humansrus 147 which was added for Nelspoortje farm. The required on-site electricity during construction period as well as its operational time could potentially obtain electricity supply from this newly constructed 11kV line.

An alternative to on-site electrical supply would be to utilise diesel generators to meet electricity requirements, or alternatively make use of an on-site smaller Solar PV system to meet the electrical need.

As part of the infrastructure installed, it is proposed to utilise on-site electricity reticulation from the on-site substation towards the required areas by utilising the accounted infrastructure. As an additional option it is proposed to make provision for the utilisation of an off-grid, on-site solar system for the required on-site electricity. Approvals of the different options in supplying on-site electricity are requested in order to allow for cost effective solutions for this project.

3.6.3 Waste, emission and noise management

3.6.3.1 Solid waste management

During the construction phase an estimated amount of less than 5 m³ non-hazardous solid construction waste are to be produced per month, for the expected 12-18 month construction period. An independent service provider will be used to safely store all construction waste, and remove it from the site on a scheduled waste removal basis.

The construction waste, where applicable, are to be disposed at a municipal landfill site that is appropriately licenced. As far as possible the waste hierarchy should be applied in order to reduce, re-use and recycle waste. The Environmental Management Programme will address solid waste management during construction. During the operational phase after construction, the facility is not expected to produce any solid wastes.

3.6.3.2 Liquid effluent (sewage)

The liquid effluent generated is expected to be minimal and limited to the ablution facilities. All workers will be transported to site on a daily basis should the workers not be housed on site. Should the workers be housed on site, sufficient temporary chemical ablution facilities will be on site during the construction phase.

These chemical toilets will be serviced and emptied on a weekly basis by a private independent contractor. The sewage will be transported to a nearby Waste Water Treatment Works for treatment. The on-site permanent sewage solution for the operation period of the facility is expected to either utilise a combination of a septic tank or french drain or a conservancy tank, as determined by the local authority. Due to the locality of the farm, sewage cannot be disposed in a municipal sewage system.

3.6.3.3 Emissions into the atmosphere and noise generation

Very little emissions should be released into the atmosphere and no significant noise should be generated, except during the construction period with drilling and hammering. Due to the site location this should not pose any issue as no residential area is located nearby.

4 Construction of the proposed facility

The proposed facility has a generating capacity of 75MW_{AC} and an installed capacity of approximately +/-86MW. The planned construction is estimated to be between 12-18 months. During the construction activities an estimated 5 jobs will be created for each 1MW_p of installed capacity. Therefore an estimated job creation of 375-450 employees are expected during the construction of the +/-85 MW_p facility, of which most will ideally be local employments.

The construction material and sourcing of required goods can be from the local community and surrounding towns. Employment of personnel during the construction and operational phase of the project will be managed by the Project Company owning the project

Should the project be approved, and all required approvals and licences are obtained from the DEA, NERSA and a Power Purchase agreement (PPA) is secured with ESKOM, the construction is envisioned to begin in the second half of 2018. A series of activities would need to be undertaken, to construct the proposed facility and associated infrastructure.

Each facility will be established in different phases, once financial close was reached, namely: the pre-construction, construction, operation and decommissioning phases.

The **preconstruction phase** typically includes the following activities:

1. Conducting of surveys
2. Appointment of contractors and sub-contractors
3. Transporting of the required construction components and equipment to site
4. Pre-construction site preparation (establishment of temporary services for construction such as lavatories, water, health and safety requirements, site office, etc.)

The **construction phase** includes:

1. Transportation of solar components and equipment to site
2. Establishment of internal access roads
3. Undertaking site preparation (including clearance of vegetation; stripping of topsoil where necessary). It should be noted that as part of the EMP the removal of protected species have been addressed.
4. Erecting of solar PV frames and modules
5. Cabling (DC) low and medium voltage (LV/MV)
6. Installing of inverter rooms
7. Establishing the underground connections between PV modules and inverters
8. Constructing the on-site substation
9. Establish connections between inverters and on-site substation
10. Establishment of additional infrastructure (workshop and maintenance buildings)
11. Connection of on-site substation to power grid
12. Undertaking site remediation
13. Construction of perimeter fencing

The activities that will be undertaken on site can be categorised under different specialist fields and include the following:

- **Civil works:** site preparation, site grading, drainage, roads, foundations, storm water & anti-erosion management and site remediation.
- **Mechanical works:** piers/sub-structure installations, mechanical assembly including trackers; mounting of PV modules; substation delivery, and lastly the installation of perimeter fencing.
- **Electrical works:** installation from low to high voltage, including substation connections.

For the purpose of the engineering report, the stages of the construction phase that have engineering considerations are discussed.

4.1 Traffic management and transportation

The traffic management and transportation section relates to all impacts the project will have on traffic and transportation infrastructure with a specific reference towards personnel transport, supplies, equipment and infrastructure transport.

All solar plant components and equipment are to be transported to the planned site by road. Construction is expected to stretch over a period of approximately 12-18 months. The Transport and Traffic plan will provide more detail on the traffic volumes, impact and corresponding regulations with regard to transportation of material and personnel which will be compiled within the impact phase.

The majority of transportation will occur during the construction period. All installation infrastructure (PV modules, substructures, cabling, inverters and other components) will be transported to the site via road. . Most of the infrastructure will be transported within standardised containerised units and corresponding container trucks (e.g. 2 x 40 ft container trucks or a similar option). The mentioned transport and traffic plan further investigates the specific routes to be used and the corresponding impact of the increased traffic on these routes, please refer to the "Humansrus Solar 4 DEIR Transport and Traffic Management Plan, March 2016".

As per transportation and traffic management plan the project has a total capacity of 75MW which would therefore require 3000 to 4000 heavy vehicle trips. The estimated time period for construction is nine months to a year, averaging 15-20 trips/ day, which is not expected to have a significant effect on peak hour traffic.

The Transport and Traffic plan provides more detail on the traffic volumes, impact and corresponding regulations with regard to transportation of material and personnel.

Normal construction traffic will also need to be taken into account. The usual civil engineering construction equipment will need to be transported to the site (e.g. excavators, trucks, graders, compaction equipment, cement trucks, etc.). The components required for the establishment of the on-site substation power line will also need to be transported to the site. Some of this power station equipment may be defined as abnormal loads in terms of the Road Traffic Act (Act No.29 of 1989). Input and approval are to be sought from the relevant road authorities for this purpose prior to the commencement of the construction phase.

The amount of hazardous substances on site is expected to be limited to fuel such as diesel and petrol. The transportation of these hazardous substances (should be done according to best transportation practices as stipulated by SANS and the National road act.

The transportation and traffic management plan further stipulates the adherence to these regulations. The onus towards complying with best practices should be on the service provider and overall project management of the project during construction.

Transport to the site will be along appropriate national, provincial and local roads. The access roads to the proposed site will be from R357 Van Wyksvlei road. This is a tarred provincial road and becomes a gravel road 625m south of the bridge crossing the decommissioned railway and no alterations should be necessary to handle construction traffic and traffic involved in the operation phase.

In some instances, the smaller farm roads may require some alterations (e.g. widening of corners etc.), due to the dimensional requirements of the loads to be transported during the construction phase (i.e. transformers of the on-site substation).

Permission from local authorities has been obtained (letter of no-objection). Further approval in terms of their generic requirements will be obtained as required prior to construction for site access and entrance road authorisation. The exact access routes that are considered are discussed in more detail within the layout report (Humansrus Solar 4 DEIR Layout Report, March 2016).

4.2 Establishment of internal access roads on the farm

Two type of roads will be required for the facility, the first being the access road to the facility from the R357 Van Wyksvlei road (as discussed in detail within the Humansrus Solar 4 Layout report). The second type of road required are internal maintenance roads on the farm and proposed construction site. Where necessary, gravel may be used to service sections of the existing road on the farm itself. The construction of internal roads could require the removal of some existing vegetation and levelling of exposed ground surface should this be found necessary.

These internal roads/tracks (typically 6 m wide or less) will form part of the development footprint. In order to allow enough space for the larger vehicles to turn easily a width of 6m will be proposed. The final and detailed layout and alignment of these internal roads will be planned and influenced by the recommendations made by the botanical specialist, as well as the topographical survey. Pathways (typically less than 4 m wide) between the solar PV modules are to be provided for ease of maintenance and cleaning of the modules.

In addition, a fire break (buffer area), which can also serve as an internal road, will be constructed around the perimeter edges of the entire proposed site. To summarise the different sizes of roads, internal roads and tracks: The main access road will be less than 8m wide, the internal roads will be approximately 6 m wide, while the internal tracks between PV modules will typically be less than 4m wide.

4.3 Site preparation

Cleaning of the surface areas might be necessary in order to construct the solar PV plant. This will be dependent on the specific frame infrastructure to be used and the specific Environmental Management Plan. This will include clearance of vegetation at the footprint of the solar PV modules, the digging of the on-site substation and workshop area foundations and the establishment of the internal access roads and lay-down areas.

Where stripping of the topsoil is required, the soil is planned to either be stockpiled, backfilled and/or spread on site. In the instance where there are cultivated areas currently on the site, the upper 30 cm of the cultivated areas is planned to be stockpiled on the boundaries of the site. The topsoil stockpiles must be protected from erosion by re-establishing vegetation (grass type of vegetation) on them. The environmental management plan will provide specifications for this vegetation re-establishment.



Figure 18: Illustration of a typical site after preparation

To reduce the risk of open ground erosion, the site preparation will typically be undertaken in a systematic manner. Where any floral species of concern or sites of cultural/heritage value are involved, measures are to be put in place to attend to the preservation or restoration of these elements as recommended by the botanical specialist and will be incorporated into the “Environmental Management Plan”.

4.4 Erecting of solar PV modules

Once the site preparation has been done, and all necessary equipment has been transported to the site, the solar PV modules and structures are assembled on site. Each solar PV module consists of a number of cells, forming a single module. Each module is capable of generating typically 200W - 400W of DC electrical power. If conventional Solar PV technology is used, the solar PV modules are assembled in blocks of rows, forming a network of strings, across the solar PV array. There is a separation distance between the rows of approximately 4 m. The exact amount of modules in each solar PV array is subject to the final facility design and will be finalised as part of the detailed design phase. If CPV technology is to be used, the distance between the modules are carefully calculated to ensure the trackers have enough room to rotate and the shadows are taken into account. Foundation holes for the solar PV modules are to be mechanically quarried to a depth of approximately 400 - 800 mm. Driven piers and screws are recommended in order to minimise the environmental impact of the facility, but will be dependent on mechanical specifications.

If concrete foundations are used, foundation holes will be mechanically excavated to a depth of about 400 - 600 mm. The concrete foundation will be poured and be left for up to a week to cure. As previously mentioned, the usage of concrete foundations would be only used if no other foundational options are viable or practical to use. In the case of concrete mixing, water bodies will be taken into consideration and mixing of concrete will not be done near water bodies (drainage lines and seasonal washes) in order to avoid contamination.



Figure 19: On-site construction of the PV arrays

4.5 Construct on-site substation

An on-site substation will be necessary to enable the connection between the solar energy plant and the National ESKOM electricity grid. The generated voltage is planned to be stepped up to 132 kV by means of an on-site substation in order to be fed to the ESKOM grid via a planned connection to the Kronos ESKOM substation. The step-up on-site substation and its associated infrastructure and internal roads might have a footprint of approximately 1ha (including a switching station, IPP transformer, IPP HV yard, ESKOM HV yard, switch gear and feeder bays).

The on-site substation is constructed in a few sequential steps. First a site is determined by the recommendations from the reports of the environmental specialists to avoid the most sensitive areas in the positioning of the substation (a geological study is expected to be conducted prior to the finalisation of the on-site substation and the detail design of the facility).

Once the site is approved, the site clearing and levelling is to be done, after which the access roads to the substation are constructed. Next the substation foundation is laid. Once the foundation is constructed, the assembly, erection and installation of all equipment, including the transformers, are to be completed. The final step is the connection of the conductors to the equipment. The post-construction phase includes the rehabilitation of disturbed areas and protection of erosion sensitive areas. Below is typical on-site substation that connects to the existing ESKOM substation.



Figure 20 : Typical on-site substation

4.6 Establishment of additional infrastructure

In order to minimise the potential ecological impact a project of this scope could have, a decision was made to limit all activities and storage of equipment to one nominated area. A dedicated construction equipment camp and lay-down area are planned to be established (further referred to as the “laydown area”), which will then form part of the auxiliary building area.

The laydown area for the construction period will be approximately 5ha. This area will typically be used for the assembly of the solar PV modules and the generation placement/storage of construction equipment.

With regard to onsite fuel storage, a temporary facility are planned to be used to secure the storage of fuel for the on-site construction vehicles. Necessary control measures will be put in place for correct transfer and use of fuel. The quantities of fuel to be stored will be determined as part of the detail facility design and operation. Refer to Section 3.1.16 earlier in the report for more discussions in terms of on-site fuel storage.

4.7 Connect on-site substation to power grid

In order to evacuate the power generated by the proposed facility and feed it into the ESKOM grid, a distribution line would have to be constructed between the proposed on-site substation and the grid connection point, Kronos substation.

According to the official ESKOM TDP 2016-2024 document, ESKOM plans to upgrade as part of Gorona strengthening the Kronos Cuprum 1st and 2nd 132kV line as well as upgrading Kronos 400/132kV transformation starting 2016.

A grid feasibility application will be submitted to ESKOM, in order to confirm the connection possibilities of this project. Refer to Section 3.5 of this report and to the “Humansrus Solar 4 DEIR Layout Report, March 2016”) for a detailed discussion regarding the different grid connection option(s).

The following figure below depicts the different alternatives of connecting to the existing ESKOM grid. Two of the options which can be investigated for grid connection are either the first of a “loop-in/loop-out” into one of the existing 132 kV lines (currently running over the farm and across the neighbouring farm) and the second option is to build a new line directly to the Kronos ESKOM substation. The “loop-in/loop-out” option has been eliminated due to feedback received from ESKOM (based on Humansrus Solar PV Energy Facility 2) that the Cuprum-Hydra line planned to be decommissioned. Humansrus Solar 4 engaged with ESKOM on the preferred grid connection point with regard to the self-build connection option where ESKOM recommended a connection to Kronos ESKOM substation. A formal investigation and application as part of the ESKOM Cost Estimate will run in parallel to this environmental process.

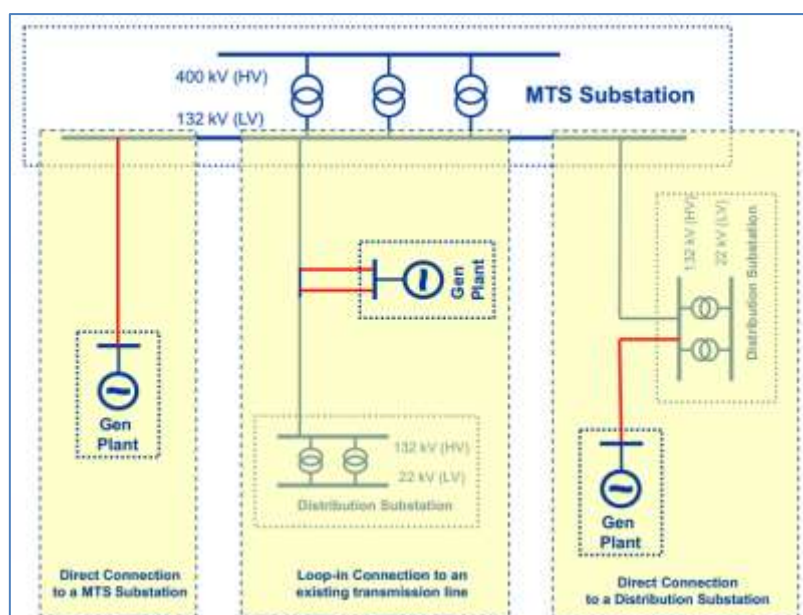

Figure 21: The different connection alternatives

This self-build power line will be constructed by the developers, but would be handed over to Eskom for operation and maintenance. Application for the new line is noted within this Environmental Process and also depicted, although a separate “Basic Assessment” (BA) will be performed for the grid connection options.

As part of the environmental impact assessment and the engagement with Eskom pertaining to a grid connection application, feedback from Eskom is expected to provide guidance towards the planned expansions, possible loop-in/loop-out options and the potential scenarios within the final Cost Estimate letter. Eskom’s recommendations will be taken into account and used within the environmental impact assessment phase as far as possible.

4.8 Undertake site remediation

Once construction is completed and once all construction equipment is removed, the site is to be rehabilitated where practical and reasonable. In the case where access routes to the site will not be used during operation, the access points are to be closed and rehabilitated as detailed in the future Environmental Management Programme.

5 Project operation and maintenance phase

The proposed operation of the site is for 25 years. During this life-cycle, the plant will be maintained and monitored. The aim is to generate at full capacity by the second half of 2019. The facility should be operational (generating electricity) during daylight hours, except during maintenance, poor weather conditions or breakdowns. Regular maintenance will typically include periodic cleaning, greasing of bearings and inspection. The modules are planned to be cleaned with water or compressed air. Any waste products are to be disposed of in accordance with the National Environmental Management: Waste Act (Act 59 of 2008).

During the operations approximately 1 job will be created for each installed MW_p of energy. The staff members will typically include technicians, maintenance and security personnel. Staff can be transported around the site using utility vehicles and a typical mini bus to transport staff from nearby towns of Prieska, Copperton and surrounding community. From time to time additional contract staff may be required for ad hoc ground cleaning or special module cleaning.

When the solar modules and associated equipment become defective, they will be recycled and re-used where possible in order to avoid the further congestion of already limited landfill space.

6 Project decommission phase

The proposed solar energy facility is expected to have a lifespan of approximately 25 years if the specified periodic maintenance is performed. If financially viable and depending on climate factors in 25 years’ time (farming may no longer be viable) the PV facility may continue operating. Existing infrastructure and components of the PV facility may be replaced with new technology.

Once the facility has reached the end of its economic life, the infrastructure is to be decommissioned.

The decommissioning of the facility would entail the disassembly and replacement of components with other appropriate technologies. However, if not deemed viable at that time, then the facility would be completely decommissioned.

Preparation activities for site decommissioning should include confirming the integrity of access to the site. Site access should be able to accommodate the required equipment (e.g. lay down areas, construction platform) and the mobilisation of decommissioning equipment.

The components would be disassembled, reused and recycled where possible, or disposed of in accordance with regulatory requirements. Functional components are planned to be donated to and installed at local schools and clinics to benefit the community as far as possible.

7 Cost implications & revenue

7.1 Project cost overview

Renewable energy projects, such as the proposed solar facility, require significant capital investment. Funds of equity and debt investors either from foreign or domestic sources are obtained. The cost requirements and potential revenue are discussed in this section, sketching a business case for the development of renewable energy projects within South Africa (specifically solar farms in the Northern Cape).

The project costs consist of two parts, capital cost and running/operational cost. The capital cost pertains to all costs incurred for the establishment of a generating facility. The running cost relates to those costs incurred to ensure that the facility operates as it should throughout its expected lifetime.

Solar PV installations can operate for many years with little maintenance or intervention. Therefore after the initial capital outlay required for building the solar power plant, further financial investment is limited. Operating costs are also limited compared to other power generation technologies.

7.2 Project specific costs

The Humansrus Solar 4 (Pty) Ltd. Project detail costing has not been completed on the date of submitting this impact engineering report. The project is, however, based on the industry standard cost with capital expenditure that can amount to more or less R15-20M per megawatt installed capacity. The running cost of a solar PV facility is minimal related to the initial capital cost, contributing to the most significant cost of constructing and running a solar PV facility.

7.3 Revenue streams

The payback of the facility results mainly from electricity sales, intended under the current governmental subsidy, known as the “Renewable Energy Independent Power Producer Procurement Programme” (REIPP Procurement Programme).

The IPP procurement programme portrays fixed ceiling prices for bidders to tender against. The establishment of these ceiling prices is based on industry standard return on investments.

The governmental study performed identified the feed-in tariff per technology related to the capital cost required per technology against its revenue potential, identifying the required subsidy per technology to be paid in order to create a lucrative investment and attract investors.

In short the subsidy offered by the governmental procurement programme (IPP procurement programme) enables the project to be financially viable by selling electricity at a subsidised price, while the costs of such a facility relates to the industry standard. The procurement program is however structured in a “competitive bidding” framework which implies that players in the market compete for the subsidy and therefore reduces the subsidy price due to price competing.

As part of the IPP procurement programme preferred bidders will enter into a power purchase agreement between the IPP generator and the Single Buyers Office/Department of Energy. National treasury provides surety, while NERSA regulates the IPP licences.

The bidding and tender procedure of the IPP procurement programme requires an approved EIA Environmental Authorisation/Record of Decision as a gate keeping criteria, where no project would be considered without an issued and valid EIA “Environmental Authorisation” (EA).

8 Project programme and timelines

As mentioned previously the Humansrus Solar 4 development is intended to be lodged under the IPP procurement programme. The programme has definite and stringent timelines, which the project should meet:

Table 4: REIPPP timelines (Round 6)

#	Description	Timeline
1	Expected IPPPP submission date (6th round)	Oct 2016
2	Preferred bidders selected	February 2017
3	Finalisation of agreements	March 2017 – September 2017
4	Procurement of infrastructure (estimate)	January 2018 – March 2018
5	Construction (estimate)	October 2017 – March 2019
6	Commissioning (estimate)	March 2019 – July 2019

The previous table clearly depicts the dependence of the project on the IPP procurement programme’s timelines. Any delay within the IPP procurement programme will have a corresponding effect on the timelines of the projects timelines.

Although no official public submission date for Round 6 have been communicated by the Department of Energy, the current additional round 4 announcements (June 2015) and round 5 publications indicate the departments (DoE) positive drive towards renewable energy generation projects and fast track of the REIPPP program. The official bidding date for Round 6 has not yet been announced by the Department of Energy, but it is expected that such dates will be made public after the announcement of preferred bidders under Round 5 (Round 4 expedited, November 2015).

9 Conclusion

In conclusion, the overall significance of the proposed Humansrus Solar 4 (Pty) Ltd. development outweighs the negative impact the project can have. From an environmental perspective the project can be well-managed with sound contingencies being put in place to prevent harm to surrounding areas.

The project does make significant contribution from a social and economic perspective. Such benefits include potential revenue for the landowner, job creation during construction during the 20-30 year operational phase. In addition, much needed electricity is generated and fed into the ESKOM national grid, taken from a natural energy resource that is sustainable and carbon-free.

Recommended mitigation measures will be developed and contained within the Environmental Management Plan (EMP). Should these mitigation measures be implemented, there should be no lasting significant negative environmental impact arising from the development of the project. This pertains to the construction phase as well as the operational phase. Solar projects use remarkable technology which can ensure a sustainable future for electricity generation. This is especially true since it does not severely impact the environment as with coal power generation or similar technologies.

In the light of the long term benefits the solar development has, should this application be approved, the project can be implemented with minimum environmental negative impacts when all sensitive areas are avoided or mitigated as proposed by the appointed specialists.