



environmental affairs

Department:
Environmental Affairs
REPUBLIC OF SOUTH AFRICA

Private Bag X 447 · PRETORIA · 0001 · Environment House · 473 Steve Biko Road · PRETORIA
Tel (+ 27 12) 399 9372

DEA Reference: 14/12/16/3/3/2/888

Enquiries: Ms. Thabile Sangweni

Telephone: (012) 399 9409 **E-mail:** TSangweni@environment.gov.za

Ms Melissa Mackay
Cape Environmental Assessment Practitioners (Pty) Ltd
PO Box 2070
GEORGE
6530

Telephone Number: (044) 874 0365
Email Address: mel@cape-eaprac.co.za

PER E-MAIL / MAIL

Dear Ms Mackay

COMMENTS ON THE DRAFT SCOPING REPORT FOR THE PROPOSED 75 MW HUMANSRUS SOLAR PV FACILITY 3 AND ITS ASSOCIATED INFRASTRUCTURE ON A PORTION OF THE FARM HUMANSRUS 147 NEAR PRIESKA WITHIN THE SIYATHEMBA LOCAL MUNICIPALITY IN THE NORTHERN CAPE PROVINCE

The draft Scoping Report (SR) and application form dated January 2016 received by this Department on 13 January 2016 refer.

This Department has the following comments on the abovementioned application:

- i. Please ensure that all relevant listed activities are applied for, are specific and that it can be linked to the development activity or infrastructure as described in the project description.
- ii. If the activities applied for in the application form differ from those mentioned in the final SR, an amended application form must be submitted. Please note that the Department's application form template has been amended and can be downloaded from the following link <https://www.environment.gov.za/documents/forms>.
- iii. Please ensure that the application form is signed by the applicant and that a signed land owner's notification form is submitted to this Department.
- iv. The final SR must investigate and identify all traffic impacts and geotechnical impacts associated with the proposed development.
- v. Please ensure that all issues raised and comments received during the circulation of the SR from registered I&APs and organs of state which have jurisdiction (including this Department's Biodiversity Section) in respect of the proposed activity are adequately addressed in the Final SR. Proof of correspondence with the various stakeholders must be included in the Final SR. Should you be unable to obtain comments, proof should be submitted to the Department of the attempts that were made to obtain comments. The Public Participation Process must be conducted in terms of Regulation 39, 40 41, 42, 43 & 44 of the EIA Regulations 2014.
- vi. Please provide a description of any identified alternatives for the proposed activity that are feasible and reasonable, including the advantages and disadvantages that the proposed activity or alternatives will have on the environment and on the community that may be affected by the activity as per Appendix 2 of the EIA Regulations, 2014. Alternatively, you should submit written proof of an investigation and motivation if no reasonable or feasible alternatives exist in terms of Appendix 2.

- vii. In accordance with Appendix 2 of the EIA Regulations 2014, the details of—
(i) the EAP who prepared the report; and
(ii) the expertise of the EAP to carry out Scoping and Environmental Impact assessment procedures; must be submitted.
- viii. You are further reminded that the final SR to be submitted to this Department must comply with all the requirements in terms of the scope of assessment and content of Scoping reports in accordance with Appendix 2 and Regulation 21(1) of the EIA Regulations, 2014.
- ix. Further note that in terms of Regulation 45 of the EIA Regulations 2014, this application will lapse if the applicant fails to meet any of the timeframes prescribed in terms of these Regulations, unless an extension has been granted in terms of Regulation 3(7).

You are hereby reminded of Section 24F of the National Environmental Management Act, Act No 107 of 1998, as amended, that no activity may commence prior to an environmental authorisation being granted by the Department.

Yours faithfully

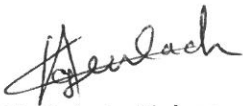

Mr Sabelo Malaza
Chief Director: Integrated Environmental Authorisations
Department of Environmental Affairs
Signed by: Mr Coenrad Agenbach
Designation: Deputy Director: Strategic Infrastructure Developments
Date: 05/02/2016

cc:	D Peinke	Humansrus Solar 3 (Pty) Ltd	Email: david@atlanticep.com
-----	----------	-----------------------------	-----------------------------



Cape Environmental Assessment Practitioners (Pty) Ltd

Reg. No. 2008/004627/07
VAT No 4720248386

Telephone: (044) 874 0365
Facsimile: (044) 874 0432

17 Progress Street, George
PO Box 2070, George 6530

Web: www.cape-eaprac.co.za

18 January 2016

Ref: SIY402/07

DEA Ref: To be confirmed

Attention: Stakeholder

VIA: Email, Fax and Post

RE: AVAILABILITY OF SCOPING REPORT FOR THE HUMANSRUS 3 SOLAR DEVELOPMENT ON PORTION OF FARM 147 HUMANSRUS, PRIESKA

Cape Environmental Assessment Practitioners (Pty) Ltd. (Cape EAPrac) has been appointed by the Applicant, **Humansrus Solar 3 (Pty) Ltd.**, as independent environmental assessment practitioner (EAP), to facilitate the Scoping & Environmental Impact Reporting (S&EIR) process required in terms of the National Environmental Management Act (NEMA, Act 107 of 1998) and 2014 Regulations for the proposed **Humansrus 3 PV Solar Development, near Prieska** in the Northern Cape.

The Applicant intends to develop a **75MW (megawatt) Photovoltaic (PV) solar power development**, with a footprint of **approximately 220ha**, on Farm 147 Humansrus, located approximately 10km south of the town of Copperton and 50kms west of Prieska. The electricity to be generated by the solar photovoltaic panels will be fed into the national grid via the **existing Kronos Substation**. Associated infrastructure will thus include a **132kV transmission line** (within an existing Eskom servitude), as well as an on-site substation, auxiliary buildings, access and internal roads, perimeter fencing etc.

The procedures for S&EIR process in terms of the 2014 Regulations (R983, R984 & R985) are being followed for this project.

This notification forms part of the Scoping phase of the Environmental Impact Assessment (EIA) process. As a registered stakeholder, you are hereby notified that the Scoping Report (SR) is available for review and comment for a period of 30 days extending from **Wednesday 20 January to Thursday 18 February 2016**.

Hard copies of the Scoping Report have been placed at the following venues for review:

- **Prieska Library** (located on Stewart Street, Prieska)
- **Siyathemba Municipality offices** (located on Victoria Street, Prieska)

Please do not remove these copies from the above venues.

A digital copy of the Scoping Report will also be available on the *Cape EAPrac* website at www.cape-eaprac.co.za. Authorities have been provided with digital copies on CD. Additional CDs are available on request.

Please submit any comments you may have to *Cape EAPrac* (contact details below) on or before **18 February 2016**:

Cape EAPrac
ATTN: Ms Melissa Mackay
P.O. Box 2070, George, 6530 Tel: 044 874 0365 Fax: 044 874 0432
E-mail: mel@cape-eaprac.co.za

Upon closing of the 30-day comment period, comments received will be considered and feedback provided, after which the comments and responses will be included in the final Scoping Report (SR) for submission to the competent authority. Please note that due to the timeframe constraints associated with the 2014 EIA Regulations, comments received after the 18th February 2016 will not be included in the final report submitted to DEA.

Please note that only registered stakeholders will be kept informed throughout the remainder of the environmental process.

If you require any further assistance, please do not hesitate to contact this office directly.

Kind regards,

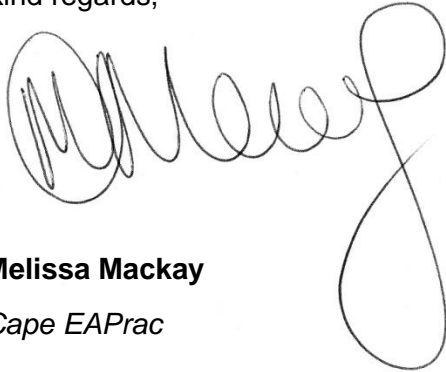

Melissa Mackay

Cape EAPrac

Review & Comment Period:
Wednesday 20 January to Thursday 18 February 2016.

Melissa Mackay

From: Melissa Mackay <mel@cape-eaprac.co.za>
Sent: 18 January 2016 02:28 PM
To: Nicole Abrahams (WR) (AbrahamsN@nra.co.za); 'mm@siyathemba.gov.za'; 'johannb@siyathemba.gov.za'; 'thokob@daff.gov.za'; 'bridgetc@ewt.org.za'; 'dekockr@nra.co.za'; 'felaarmb@eskom.co.za'; 'geerinjh@eskom.co.za'; 'phine@sahra.org.za'; 'hohned@dwa.gov.za'; 'mjh@lantic.net'; 'humanwj@gmail.com'; 'nielj07@vodamail.co.za'; 'juliusg@nra.co.za'; koegelenbergj@sentech.co.za; 'leaskk@eskom.co.za'; slekota@environment.gov.za; 'jacolinema@daff.gov.za'
Cc: 'mashuduma@daff.gov.za'; 'Pheladi Masipa'; 'MatjudD@eskom.co.za'; 'ayandam@doc.gov.za'; Melanie Miles (MelanieM@L2B.co.za); 'tmtho@webmail.co.za'; 'mmboneni.mutheiwana@dmr.gov.za'; 'peter.novellie@sanparks.org'
Subject: Humansrus PV Solar 3 - Availability of Scoping Report
Attachments: SIY402.07 SR Notification Jan16.pdf; Issues and Responses SR 18Jan16.pdf

Tracking:

Recipient

Read

Nicole Abrahams (WR) (AbrahamsN@nra.co.za)

'mm@siyathemba.gov.za'

'johannb@siyathemba.gov.za'

'thokob@daff.gov.za'

'bridgetc@ewt.org.za'

'dekockr@nra.co.za'

'felaarmb@eskom.co.za'

'geerinjh@eskom.co.za'

'phine@sahra.org.za'

'hohned@dwa.gov.za'

'mjh@lantic.net'

'humanwj@gmail.com'

'nielj07@vodamail.co.za'

'juliusg@nra.co.za'

koegelenbergj@sentech.co.za

'leaskk@eskom.co.za'

slekota@environment.gov.za

'jacolinema@daff.gov.za'

'mashuduma@daff.gov.za'

'Pheladi Masipa'

'MatjudD@eskom.co.za'

'ayandam@doc.gov.za'

Melanie Miles (MelanieM@L2B.co.za)

Read: 2016-01-18 02:30 PM

'tmtho@webmail.co.za'

'mmboneni.mutheiwana@dmr.gov.za'

'peter.novellie@sanparks.org'

Good afternoon

RE: AVAILABILITY OF SCOPING REPORT – HUMANSRUS PV SOLAR 3

Thank you for your participation in this EIA process to date. Please be advised that the Scoping Report, including comments received pre-application is available for comment and review. The Application for Environmental Authorisation was submitted to the national Department of Environmental Affairs (DEA) on 8 January 2016. In order to comply with the timeframes of the 2014 EIA Regulations, this report is available for a period of 30 days from Wednesday 20th January to Thursday 18th February 2016.

For ease of reference a copy of the Issues & Responses report has been included with this notification. Please ensure that your comments are submitted no later than 18th February 2016.

Regards

Melissa Mackay | 084 584 7419
SENIOR CONSULTANT | ECO | GIS
8 Tech Nature Conservation (NMMU)

T: 044 874 0365
F: 044 874 0432
17 Progress Street, George
P O Box 2070, George 6530

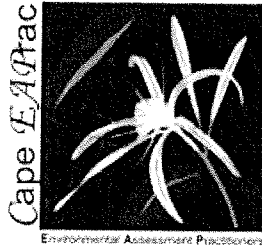

Reduce Reuse Recycle

In the interest of resource conservation please reconsider printing this email.

This message and any attachments to it contains privileged and confidential information intended only for the use of the addressee. If you are not the addressee you are hereby notified that you may not disseminate, copy or take action in respect of its contents. If you have received this message in error please notify Cape EAPrac immediately and return it to the above address. The views expressed in this message are not necessarily the views of Cape EAPrac, its Directors or Staff and no liability is accepted as a result of the contents expressed herein.

Melissa Mackay

From: Melissa Mackay <mel@cape-eaprac.co.za>
Sent: 18 January 2016 02:41 PM
To: 'Ronald.Marais@eskom.co.za'; pixley@telkomsa.net;
'nomawethu.qase@energy.gov.za'; 'energy@birdlife.org.za';
TRatlou@environment.gov.za; 'ntsundeni.ravhugoni@dmr.gov.za';
'gloriaspeelman.gs@gmail.com'; 'dstander@ncpg.gov.za'; 'strohl@caa.co.za';
'ratha.timothy@gmail.com'; 'Adrian Tiplady'; 'ntoerien1@gmail.com'; 'Justine
Wyngaardt'; 'nyende@ncpg.gov.za'
Subject: Humansrus PV Solar 3 - Availability of Scoping Report
Attachments: SIY402.07 SR Notification Jan16.pdf; Issues and Responses SR 18Jan16.pdf

Good afternoon

RE: AVAILABILITY OF SCOPING REPORT – HUMANSRUS PV SOLAR 3

Thank you for your participation in this EIA process to date. Please be advised that the Scoping Report, including comments received pre-application is available for comment and review. The Application for Environmental Authorisation was submitted to the national Department of Environmental Affairs (DEA) on 8 January 2016. In order to comply with the timeframes of the 2014 EIA Regulations, this report is available for a period of 30 days from Wednesday 20th January to Thursday 18th February 2016.

For ease of reference a copy of the Issues & Responses report has been included with this notification. Please ensure that your comments are submitted no later than 18th February 2016.

Regards

Melissa Mackay | 084 584 7419
SENIOR CONSULTANT | ECO | GIS
B. Tech Nature Conservation (NMMU)

T: 044 874 0365
F: 044 874 0432
17 Progress Street, George
P O Box 2070, George 6530

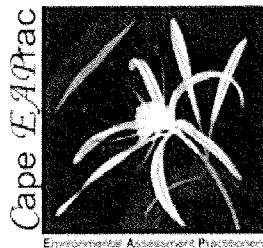

Reduce Reuse Recycle

In the interest of resource conservation please reconsider printing this email.

This message and any attachments to it contains privileged and confidential information intended only for the use of the addressee. If you are not the addressee you are hereby notified that you may not disseminate, copy or take action in respect of its contents. If you have received this message in error please notify Cape EAPrac immediately and return it to the above address. The views expressed in this message are not necessarily the views of Cape EAPrac, its Directors or Staff and no liability is accepted as a result of the contents expressed herein.

Melissa Mackay

From: Mail Delivery System <Mailer-Daemon@antispam2-jnb1.host-h.net>
Sent: 18 January 2016 02:30 PM
To: mel@cape-eaprac.co.za
Subject: Mail delivery failed: returning message to sender

This message was created automatically by mail delivery software.

A message that you sent could not be delivered to one or more of its recipients. This is a permanent error. The following address(es) failed:

mjh@lantic.net
host aialantic-jhb02ip.lantic.net [196.41.6.227]
SMTP error from remote mail server after RCPT TO:<mjh@lantic.net>:
550 #5.1.0 Address rejected.

----- This is a copy of the message, including all the headers. -----
----- The body of the message is 707035 characters long; only the first
----- 106496 or so are included here.

Return-path: <mel@cape-eaprac.co.za>
Received: from dedi251.jnb2.host-h.net ([41.203.16.251])
by antispam2-jnb1.host-h.net with esmtpsa (TLSv1.2:DHE-RSA-AES128-SHA:128)
(Exim 4.85)
(envelope-from <mel@cape-eaprac.co.za>)
id 1aL8vX-0008U9-H2; Mon, 18 Jan 2016 14:29:09 +0200
Received: from [105.224.7.240] (helo=Melissa)
by dedi251.jnb2.host-h.net with esmtpa (Exim 4.80)
(envelope-from <mel@cape-eaprac.co.za>)
id 1aL8v6-00031l-91; Mon, 18 Jan 2016 14:28:50 +0200
Return-Receipt-To: "Melissa Mackay" <mel@cape-eaprac.co.za>
Reply-To: <mel@cape-eaprac.co.za>
From: "Melissa Mackay" <mel@cape-eaprac.co.za>
To: "Nicole Abrahams \\\(WR\\)" <AbrahamsN@nra.co.za>,
<mm@siyathemba.gov.za>,
<johannb@siyathemba.gov.za>,
<thokob@daff.gov.za>,
<bridgetc@ewt.org.za>,
<dekoockr@nra.co.za>,
<felaarmb@eskom.co.za>,
<geerinjh@eskom.co.za>,
<phine@sahra.org.za>,
<hohned@dwa.gov.za>,
<mjh@lantic.net>,
<humanwj@gmail.com>,
<nielj07@vodamail.co.za>,
<juliusg@nra.co.za>,
<koegelenbergj@sentech.co.za>,
<leaskk@eskom.co.za>,
<slekota@environment.gov.za>,
<jacolinema@daff.gov.za>
Cc: <mashuduma@daff.gov.za>,
"Pheladi Masipa" <Pheladi.Masipa@energy.gov.za>

Melissa Mackay

From: Hohne Danita <HohneD@dws.gov.za>
Sent: 18 January 2016 02:29 PM
To: Melissa Mackay
Subject: Automatic reply: Humansrus PV Solar 3 - Availability of Scoping Report

On leave till 20 Jan

DISCLAIMER: This message and any attachments are confidential and intended solely for the addressee. If you have received this message in error, please notify the system manager/sender. Any unauthorized use, alteration or dissemination is prohibited. The Department of Water and Sanitation further accepts no liability whatsoever for any loss, whether it be direct, indirect or consequential, arising from this e-mail, nor for any consequence of its use or storage.

Melissa Mackay

From: Hohne Danita <HohneD@dws.gov.za>
Sent: 18 January 2016 02:29 PM
To: Melissa Mackay
Subject: Automatic reply: Humansrus PV Solar 3 - Availability of Scoping Report

On leave till 20 Jan

DISCLAIMER: This message and any attachments are confidential and intended solely for the addressee. If you have received this message in error, please notify the system manager/sender. Any unauthorized use, alteration or dissemination is prohibited. The Department of Water and Sanitation further accepts no liability whatsoever for any loss, whether it be direct, indirect or consequential, arising from this e-mail, nor for any consequence of its use or storage.

Melissa Mackay

From: Kevin Leask <LeaskK@eskom.co.za>
Sent: 18 January 2016 02:30 PM
To: Melissa Mackay
Subject: Automatic reply: Humansrus PV Solar 3 - Availability of Scoping Report

I am out of the office until Monday, 1 February 2016.
If matter is urgent please contact Ronald Marais at Ronald.Marais@eskom.co.za.

Thank you
Kevin Leask

I'm part of the 49Million initiative...
<http://www.49Million.co.za>

NB: This Email and its contents are subject to the Eskom Holdings SOC Limited EMAIL LEGAL NOTICE which can be viewed at http://www.eskom.co.za/Pages/Email_Legal_Spam_Disclaimer.aspx

Melissa Mackay

From: Melanie Miles <MelanieM@L2B.co.za>
To: Melissa Mackay; Melissa Mackay
Sent: 18 January 2016 02:30 PM
Subject: Read: Humansrus PV Solar 3 - Availability of Scoping Report

This is a receipt for the email message you sent to
"Nicole Abrahams (WR)" <AbrahamsN@nra.co.za>; <mm@siyathemba.gov.za>;
<johannb@siyathemba.gov.za>; <thokob@daff.gov.za>; <bridgetc@ewt.org.za>;
<decockr@nra.co.za>; <felaarmb@eskom.co.za>; <geerijnh@eskom.co.za>;
<phine@sahra.org.za>; <hohned@dwa.gov.za>; <mjh@lantic.net>;
<humanwj@gmail.com>; <nielj07@vodamail.co.za>; <juliusg@nra.co.za>;
<koegelenbergj@sentech.co.za>; <leaskk@eskom.co.za>;
<slekota@environment.gov.za>; <jacolinema@daff.gov.za> at 2016/01/18 02:28
PM

This receipt verifies that the message has been displayed on the
recipient's computer at 2016/01/18 02:30 PM

Melissa Mackay

From: Seoka Lekota <SLekota@environment.gov.za>
Sent: 18 January 2016 02:31 PM
To: Melissa Mackay
Subject: Automatic reply: Humansrus PV Solar 3 - Availability of Scoping Report

Good Day

Please note that, i am out of the office and will be back on **20/01/2016**. During this period i will have limited access to my email.

Kind Regards
SEoka Lekota

This message and any attachments transmitted with it are intended solely for the addressee(s) and may be legally privileged and/or confidential. If you have received this message in error please destroy it and notify the sender. Any unauthorized usage, disclosure, alteration or dissemination is prohibited. The Department of Environmental Affairs accepts no responsibility for any loss whether it be direct, indirect or consequential, arising from information made available and actions resulting there from. The views and opinions expressed in this e-mail message may not necessarily be those of Management.

Melissa Mackay

From: Pheladi Masipa <Pheladi.Masipa@energy.gov.za>
Sent: 18 January 2016 02:30 PM
To: Melissa Mackay
Subject: Read: Humansrus PV Solar 3 - Availability of Scoping Report
Attachments: Read: Humansrus PV Solar 3 - Availability of Scoping Report (6,60 KB)

This e-mail message is subject to the Department of Energy disclaimer, which may be viewed by clicking on the following link: <http://www.energy.gov.za/disclaimer.htm>

Melissa Mackay

From: John Geeringh <GeerinJH@eskom.co.za>
To: Melissa Mackay
Sent: 18 January 2016 02:37 PM
Subject: Read: Humansrus PV Solar 3 - Availability of Scoping Report

Your message

To: John Geeringh
Subject: Humansrus PV Solar 3 - Availability of Scoping Report
Sent: Monday, January 18, 2016 2:28:26 PM (UTC+02:00) Harare, Pretoria

was read on Monday, January 18, 2016 2:36:00 PM (UTC+02:00) Harare, Pretoria.

I'm part of the 49Million initiative...
<http://www.49Million.co.za>

NB: This Email and its contents are subject to the Eskom Holdings SOC Limited EMAIL LEGAL NOTICE which can be viewed at
http://www.eskom.co.za/Pages/Email_Legal_Spam_Disclaimer.aspx

Melissa Mackay

From: Noma Qase <Noma.Qase@energy.gov.za>
Sent: 18 January 2016 02:40 PM
To: Melissa Mackay
Subject: Automatic reply: Humansrus PV Solar 3 - Availability of Scoping Report

Thank you for the correspondence. I am on leave until 22 Jan 2015 and will not be responding to any emails during this time. For urgent queries kindly contact Mr Niveshen Govender on 012 406 or Mr Khanyiso Zihlangu on 012 406 7651. Be blessed, Noma.

This e-mail message is subject to the Department of Energy disclaimer, which may be viewed by clicking on the following link: <http://www.energy.gov.za/disclaimer.htm>

Melissa Mackay

From: Johan Koegelenberg <KoegelenbergJ@sentech.co.za>
To: Melissa Mackay
Sent: 18 January 2016 04:05 PM
Subject: Read: Humansrus PV Solar 3 - Availability of Scoping Report

Your message was read on 18 January 2016 02:04:40 PM UTC.

[#WeAreAfrica](#)

DISCLAIMER:

This email contains confidential information. It may also be legally privileged. Interception of this email is illegal. The information contained in this email is only for the use of the intended recipient. If you are not the intended recipient, any disclosure, copying and/or distribution of the contents of this email, or the taking of any action in reliance thereon or pursuant thereto, is strictly prohibited. Should you have received this email in error, please notify us immediately by return email.

Melissa Mackay

From: Mmboneni Mutheiwana <MMboneni.Mutheiwana@dmr.gov.za>
To: Melissa Mackay
Sent: 18 January 2016 03:15 PM
Subject: Read: Humansrus PV Solar 3 - Availability of Scoping Report

Your message

To: Mmboneni Mutheiwana
Subject: Humansrus PV Solar 3 - Availability of Scoping Report
Sent: Monday, January 18, 2016 2:28:26 PM (UTC+02:00) Harare, Pretoria

was read on Monday, January 18, 2016 3:14:42 PM (UTC+02:00) Harare, Pretoria.

Melissa Mackay

From: Mmboneni Mutheiwana <MMboneni.Mutheiwana@dmr.gov.za>
Sent: 18 January 2016 03:15 PM
To: mel@cape-eaprac.co.za
Subject: RE: Humansrus PV Solar 3 - Availability of Scoping Report

Noted with thanks

Mr. Mmboneni Kevin Mutheiwana
Deputy Director: Mineral Laws and Administration (Northern Cape Region)
Mineral Regulation

| +27 (0)53 807 1707 | +27 (0)86 710 1548 | +27 (0) 82 494 3984 |
| Mmboneni.Mutheiwana@dmr.gov.za Website: www.dmr.gov.za |

| 65 Phakamile Mabija Street | Permanent Building | Kimberley | Switchboard: +27 (0)53 807 1700 |

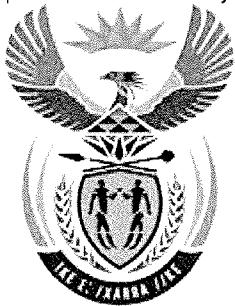

mineral resources

Department:
Mineral Resources
REPUBLIC OF SOUTH AFRICA

From: Melissa Mackay [<mailto:mel@cape-eaprac.co.za>]

Sent: 18 January 2016 02:28 PM

To: Nicole Abrahams (WR); mm@siyathemba.gov.za; johannb@siyathemba.gov.za; thokob@daff.gov.za; bridgetc@ewt.org.za; dekokkr@nra.co.za; felaarmb@eskom.co.za; geerinjh@eskom.co.za; phine@sahra.org.za; hohned@dwa.gov.za; mjh@lantic.net; humanwj@gmail.com; nielj07@vodamail.co.za; juliusg@nra.co.za; koegelenbergj@sentech.co.za; leaskk@eskom.co.za; slekota@environment.gov.za; jacolinema@daff.gov.za

Cc: mashuduma@daff.gov.za; 'Pheladi Masipa'; MatjudD@eskom.co.za; ayandam@doc.gov.za; Melanie Miles; tmtho@webmail.co.za; Mmboneni Mutheiwana; peter.novellie@sanparks.org

Subject: Humansrus PV Solar 3 - Availability of Scoping Report

Good afternoon

RE: AVAILABILITY OF SCOPING REPORT – HUMANSRUS PV SOLAR 3

Thank you for your participation in this EIA process to date. Please be advised that the Scoping Report, including comments received pre-application is available for comment and review. The Application for Environmental Authorisation was submitted to the national Department of Environmental Affairs (DEA) on 8 January 2016. In order to comply with the timeframes of the 2014 EIA Regulations, this report is available for a period of 30 days from Wednesday 20th January to Thursday 18th February 2016.

For ease of reference a copy of the Issues & Responses report has been included with this notification. Please ensure that your comments are submitted no later than 18th February 2016.

Regards

Melissa Mackay | 084 584 7419
SENIOR CONSULTANT | ECO | GIS
B.Tech Nature Conservation (NMMU)

T: 044 874 0365
F: 044 874 0432
17 Progress Street, George
PO Box 2070, George 6530

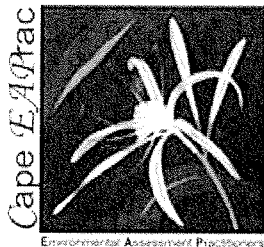

Reduce Reuse Recycle

In the interest of resource conservation please reconsider printing this email.

This message and any attachments to it contains privileged and confidential information intended only for the use of the addressee. If you are not the addressee you are hereby notified that you may not disseminate, copy or take action in respect of its contents. If you have received this message in error please notify Cape EAPrac immediately and return it to the above address. The views expressed in this message are not necessarily the views of Cape EAPrac, its Directors or Staff and no liability is accepted as a result of the contents expressed herein.



This email has been sent from a virus-free computer protected by Avast.
www.avast.com

Melissa Mackay

From: Natasha Higgitt <nhiggitt@sahra.org.za>
Sent: 18 January 2016 03:04 PM
To: mel@cape-eaprac.co.za
Cc: Phillip Hine
Subject: Re: Humansrus PV Solar 3 - Availability of Scoping Report

Thank you for notifying SAHRA about the proposed development. Please note that we do not accept hard copy or email submissions and require you to load all relevant documents to the South African Heritage Resources Information System - SAHRIS (<http://www.sahra.org.za/sahris/>).

If you have not registered as a user, please follow the guide provided and create a case for the development. We will issue comments on the case once all documents have been uploaded to the case file. Please note that the Heritage Report must be submitted as a separate document on the case file and not as part of the Scoping Report.

If you have any queries, please contact the case officer who will be assigned to your case once it has been created on SAHRIS.

Kind Regards,

Natasha Higgitt
Heritage Officer: Archaeology, Palaeontology and Meteorites Unit

South African Heritage Resources Agency
- A nation united through heritage -

T: +27 21 462 4502 | C: +27 82 507 0378 | F: +27 21 462 4509
E: nhiggitt@sahra.org.za | 111 Harrington Street | Cape Town

www.sahra.org.za

From: "Melissa Mackay" <mel@cape-eaprac.co.za>
To: "Nicole Abrahams (WR)" <AbrahamsN@nra.co.za>, mm@siyathemba.gov.za, johannb@siyathemba.gov.za, thokob@daff.gov.za, bridgetc@ewt.org.za, dekokkr@nra.co.za, felaarmb@eskom.co.za, geerinh@eskom.co.za, phine@sahra.org.za, hohned@dwa.gov.za, mjh@lantic.net, humanwj@gmail.com, nielj07@vodamail.co.za, juliusg@nra.co.za, koegelenbergj@sentech.co.za, leaskk@eskom.co.za, slekota@environment.gov.za, jacolinema@daff.gov.za
Cc: mashuduma@daff.gov.za, "Pheladi Masipa" <Pheladi.Masipa@energy.gov.za>, MatjudD@eskom.co.za, ayandam@doc.gov.za, "Melanie Miles" <MelanieM@L2B.co.za>, tmtho@webmail.co.za, "mmboneni mutheiwana" <mmboneni.mutheiwana@dmr.gov.za>, "peter novellie" <peter.novellie@sanparks.org>
Sent: Monday, 18 January, 2016 2:28:26 PM
Subject: Humansrus PV Solar 3 - Availability of Scoping Report

Good afternoon

RE: AVAILABILITY OF SCOPING REPORT – HUMANSRUS PV SOLAR 3

Thank you for your participation in this EIA process to date. Please be advised that the Scoping Report, including comments received pre-application is available for comment and review. The Application for

Environmental Authorisation was submitted to the national Department of Environmental Affairs (DEA) on 8 January 2016. In order to comply with the timeframes of the 2014 EIA Regulations, this report is available for a period of 30 days from Wednesday 20th January to Thursday 18th February 2016.

For ease of reference a copy of the Issues & Responses report has been included with this notification. Please ensure that your comments are submitted no later than 18th February 2016.

Regards

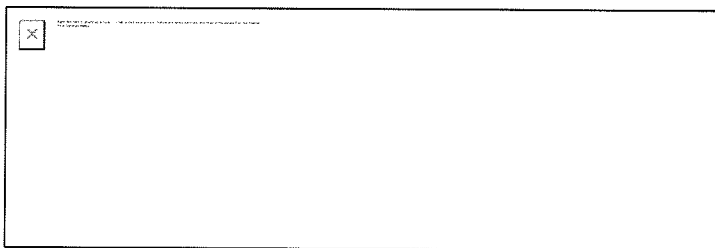

Reduce Reuse Recycle

In the interest of resource conservation please reconsider printing this email.

This message and any attachments to it contains privileged and confidential information intended only for the use of the addressee. If you are not the addressee you are hereby notified that you may not disseminate, copy or take action in respect of its contents. If you have received this message in error please notify Cape EAPrac immediately and return it to the above address. The views expressed in this message are not necessarily the views of Cape EAPrac, its Directors or Staff and no liability is accepted as a result of the contents expressed herein.



This email has been sent from a virus-free computer protected by Avast.
www.avast.com

This electronic communication and its content(s) are subject to a disclaimer which can be accessed here: <http://mail.sahra.org.za/disclaimer.html>

Phillip Hine

Acting Manager: Archaeology, Palaeontology & Meteorites Unit

South African Heritage Resources Agency

- A nation united through heritage -

T: +27 21 462 4502 / +27 21 202 8652| C:+27 83 7933 852| F:+27 21 462 4509
E: phine@sahra.org.za | | |

www.sahra.org.za

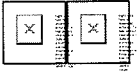

This electronic communication and its content(s) are subject to a disclaimer which can be accessed here: <http://mail.sahra.org.za/disclaimer.html>

Natasha Higgitt

South African Heritage Resources Agency
- *A nation united through heritage* -

T: | C:| F:
E: nhiggitt@sahra.org.za | |

www.sahra.org.za

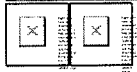

This electronic communication and its content(s) are subject to a disclaimer which can be accessed here: <http://mail.sahra.org.za/disclaimer.html>

Melissa Mackay

From: Ntsundeni Ravhugoni <Ntsundeni.Ravhugoni@dmr.gov.za>
To: Melissa Mackay
Sent: 18 January 2016 03:46 PM
Subject: Read: Humansrus PV Solar 3 - Availability of Scoping Report

Your message

To: Ntsundeni Ravhugoni
Subject: Humansrus PV Solar 3 - Availability of Scoping Report
Sent: Monday, January 18, 2016 2:40:47 PM (UTC+02:00) Harare, Pretoria

was read on Monday, January 18, 2016 3:45:25 PM (UTC+02:00) Harare, Pretoria.

Melissa Mackay

From: Pixley ka Seme District Municipality <pixley@telkomsa.net>
To: 'Melissa Mackay'
Sent: 18 January 2016 03:56 PM
Subject: Read: Humansrus PV Solar 3 - Availability of Scoping Report

Your message

To: Unknown
Subject:

Melissa Mackay

From: Lizelle Stroh <StrohL@caa.co.za>
To: Melissa Mackay
Sent: 19 January 2016 11:21 AM
Subject: Read: Humansrus PV Solar 3 - Availability of Scoping Report

Your message

To: Lizelle Stroh
Subject: Humansrus PV Solar 3 - Availability of Scoping Report
Sent: Monday, January 18, 2016 2:40:47 PM (UTC+02:00) Harare, Pretoria

was read on Tuesday, January 19, 2016 11:20:15 AM (UTC+02:00) Harare, Pretoria.

SM 402



Messrs A. de Jager

Po Box 233

Priesta

8940



Cape EAPrac
P.O. Box 2070 / George 6530
17 Progress Street
Tel: 044 874 0365 Fax: 044 874 0432
Web: www.cape-eaprac.co.za

SM 402



Messrs. N. Fanie

Po Box 382

Priesta

8940



Cape EAPrac
P.O. Box 2070 / George 6530
17 Progress Street
Tel: 044 874 0365 Fax: 044 874 0432
Web: www.cape-eaprac.co.za

SM 402

Mbewu Mining (Pty) Ltd
P.O. Box 2449
Johannesburg
2041

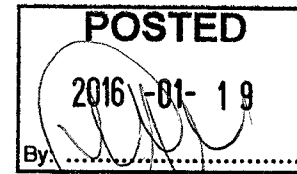

Cape EAPrac
P.O. Box 2070 / George 6530
17 Progress Street
Tel: 044 874 0365 Fax: 044 874 0432
Web: www.cape-eaprac.co.za

SM 402

Van Wyk Broers
Po Box 217
Prieska
8940

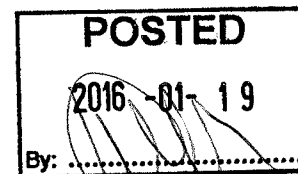

Cape EAPrac
P.O. Box 2070 / George 6530
17 Progress Street
Tel: 044 874 0365 Fax: 044 874 0432
Web: www.cape-eaprac.co.za

Send Result Report



MFP

TASKalfa 250ci

Firmware Version 2H7_2F00.013.006 2012.01.06

18/01/2016 15:35
[2JZ_1000.024.001] [2H7_1100.002.003] [2H7_7000.013.006]

Job No.: 008780

Total Time: 0°03'18"

Page: 002

Error occurred

Document: doc20160118152629

No.	Date and Time	Destination	Times	Type	Result	Resolution/ECM
001	18/01/16 15:26	0123495938	0°02'10"	FAX	BUSY	200x100 Normal/Off
002	18/01/16 15:27	0538316501	0°00'42"	FAX	OK	200x100 Normal/On
003	18/01/16 15:29	0538077328	0°00'26"	FAX	OK	200x100 Normal/On



0861 223 224

www.dawnwing.co.za

WAYBILL



1265538702

FROM: CAPE TOWN
Address: 17 PROGRESS STR GEORGE
City/Country: RSA
Postal Code: 6529

Senders Name: MELISSA MACKAY
044 8740 365

TO: PRIESKA LIBRARY
Street Address (P.O. Box Addresses not accepted): STEWART STR PRIESKA
City/Country: RSA
Postal Code: 8940

Receiver's Name: DALENE
053 3535305

Senders Name: MELISSA MACKAY
Date: 19/11/16
Signature: [Signature]

Collected By Courier: [Signature]
Date: [Blank]
Time: [Blank]

Contents: DOCUMENTS
HAZARDOUS: YES (NO)
PARCEL DETAILS:
No. of Parcels: 1
Vol(kg)- T's & C's Apply*: [Blank]
Mass(kg)- T's & C's Apply*: [Blank]
Dimensions (cm): L 40 W 30 H 2
Dawn Wing reserves the right to mark the service "Overnight Express" should no service level be selected
Terms strictly 30 days from date of statement
CASH AMOUNT: R [Blank] PAID: YES NO
Special Instructions: [Blank]

Filing Ref: [Blank]

SERVICE (mark only one):
Overnight Express, Economy Cargo, Domestic Road Freight, Sameday Express, International Documents, International Non Documents, International Air Freight, International Road Freight

SPECIAL INSTRUCTIONS:
Tick to select limited liability option (to a maximum amount of R50 000) for non-excluded articles: [Blank]
Customs Value ZAR: [Blank] Value of Article ZAR: [Blank]
Account to be Debited: [Blank]
Sender's Ref. / Bag No.: 517402/407
RECEIVED IN GOOD ORDER AND CONDITION
Receivers Signature: [Blank]
Print Name: [Blank]
Date: [Blank] Time: [Blank]

DAWN WING
A Division of DPD Laser Express Logistics (Pty) Ltd
Reg. No. 2006/033353/07 VAT No. 4690235280
FSP No. 32010

*All weight and dimensions subject to verification through electronic weight and dimension machine (SABS calibrated)

SENDER'S COPY



0861 223 224

www.dawnwing.co.za

WAYBILL



1265538713

FROM: CAPE TOWN
Address: 17 PROGRESS STR GEORGE
City/Country: RSA
Postal Code: 6529

Senders Name: MELISSA MACKAY
044 8740 365

TO: SIYATHEMBA MUNICIPALITY
Street Address (P.O. Box Addresses not accepted): VICTORIA STREET PRIESKA
City/Country: RSA
Postal Code: 8940

Receiver's Name: RECEPTION
053 3535317

Senders Name: MELISSA MACKAY
Date: 19/11/16
Signature: [Signature]

Collected By Courier: [Signature]
Date: [Blank]
Time: [Blank]

Contents: DOCUMENTS
HAZARDOUS: YES (NO)
PARCEL DETAILS:
No. of Parcels: 1
Vol(kg)- T's & C's Apply*: [Blank]
Mass(kg)- T's & C's Apply*: [Blank]
Dimensions (cm): L 40 W 30 H 2
Dawn Wing reserves the right to mark the service "Overnight Express" should no service level be selected
Terms strictly 30 days from date of statement
CASH AMOUNT: R [Blank] PAID: YES NO
Special Instructions: [Blank]

Filing Ref: [Blank]

SERVICE (mark only one):
Overnight Express, Economy Cargo, Domestic Road Freight, Sameday Express, International Documents, International Non Documents, International Air Freight, International Road Freight

SPECIAL INSTRUCTIONS:
Tick to select limited liability option (to a maximum amount of R50 000) for non-excluded articles: [Blank]
Customs Value ZAR: [Blank] Value of Article ZAR: [Blank]
Account to be Debited: [Blank]
Sender's Ref. / Bag No.: 517402/407
RECEIVED IN GOOD ORDER AND CONDITION
Receivers Signature: [Blank]
Print Name: [Blank]
Date: [Blank] Time: [Blank]

DAWN WING
A Division of DPD Laser Express Logistics (Pty) Ltd
Reg. No. 2006/033353/07 VAT No. 4690235280

*All weight and dimensions subject to verification through electronic weight and dimension machine (SABS calibrated)

SENDER'S COPY

Sender to complete yellow areas only

Sender to complete yellow areas only

www.cape-eaprac.co.za/index.php?option=com_content&view=article&id=225:humansrus-solar-pv-energy-facility-3&catid=9:active-projects&Itemid=102

Apps Current Legislation Year 2015 Calendar... GridWatch - Brough... George Weather - A... CapeFarmMapper Welcome SAAELIP WhatsApp Web Other bookmarks

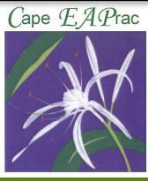

Cape EAPrac

You are here: Home > Active Projects > Humansrus Solar PV Energy Facility 3

Humansrus Solar PV Energy Facility 3

Created on Thursday, 19 November 2015 23:18 | Last Updated on Tuesday, 19 January 2016 12:49

ONLINE REGISTRATION FORM

Consultant: Melissa Mackay (mel@cape-eaprac.co.za)
 Comment Period: ~~19 January to 24 January 2016~~

Scoping Report

Pre Application Scoping Report

Departmental Links

- National Environmental Affairs
- Provincial Environmental Affairs
- Department of Water Affairs
- Heritage Western Cape

Latest Projects

- Humansrus Solar PV Energy Facility 4
- Humansrus Solar PV Energy Facility 3
- The Hill, Sedgefield
- Brandkop Boerdery
- Still Bay Arterial Road
- Cavalier Abattoir Throughput
- Great Brak Services Upgrade

Main Menu: Home, Staff, Contact us; Projects: Active Projects, Archived Projects, Environmental Control; Associates: Doug Jeffery, Total Impact; Resources: Town Planners

03:32 PM 2016-01-19

www.cape-eaprac.co.za/index.php?option=com_content&view=article&id=236

Apps Current Legislation Year 2015 Calendar... GridWatch - Brough... George Weather - A... CapeFarmMapper Welcome SAAELIP WhatsApp Web Other bookmarks

You are here: Home

Articles

Humansrus Solar PV Energy Facility 3 SR

Created on Monday, 18 January 2016 23:18 | Last Updated on Tuesday, 19 January 2016 12:02

ONLINE REGISTRATION FORM

Consultant: Melissa Mackay (mel@cape-eaprac.co.za)
 Comment Period: ~~19 January to 24 January 2016~~

Scoping Report

- Appendix A: Location Plans
- Appendix B: Biodiversity Overlays
- Appendix C: Site Photographs
- Appendix D: Site layout and Report
- Appendix E: Specialist Reports
- Annexure E1: Ecological Scoping Report
- Annexure E2: Agricultural Potential Report
- Annexure E3: Heritage Scoping Report
- Annexure E4: Archaeological Scoping Report
- Annexure E5: Palaeontological Report (Pending)
- Annexure E6: Visual Scoping Report
- Annexure E7: Engineering Scoping Report
- Appendix F: Public Participation
- Annexure F1: Stakeholder List
- Annexure F2: Pre-Application Public Participation
- Annexure F3: Scoping Report Notifications
- Annexure F4: Scoping Report Comments (Pending)
- Annexure F5: Final Scoping Report Notifications (Pending)
- Annexure F6: Comments & Responses Table
- Appendix G: Authority Correspondence
- Appendix H: EAP CV & Declaration
- Appendix I: Additional Information
- Annexure I: Landowner Consent

Departmental Links

- National Environmental Affairs
- Provincial Environmental Affairs
- Department of Water Affairs
- Heritage Western Cape

Latest Projects

- Humansrus Solar PV Energy Facility 4
- Humansrus Solar PV Energy Facility 3
- The Hill, Sedgefield
- Brandkop Boerdery
- Still Bay Arterial Road
- Cavalier Abattoir Throughput
- Great Brak Services Upgrade
- Dyasonsklip Solar Energy Facility 2
- AEP Kathu PV Solar Facility
- Bitou Public Safety Centre

Main Menu: Home, Staff, Contact us; Projects: Active Projects, Archived Projects, Environmental Control; Associates: Doug Jeffery, Total Impact; Resources: Town Planners, Engineers, Biodiversity Specialists, Visual Specialists, Heritage Specialists, Legal; Environmental Links: WESSA, IAASA, Envirospanda, Botanical Society of SA

03:33 PM 2016-01-19



SKA SOUTH AFRICA
SQUARE KILOMETRE ARRAY

17 Baker Street
Rosebank
Johannesburg
South Africa
2196

Tel: +27 (0) 11 442 2434
Fax: +27 (0) 11 442 2454
Email: atiplady@ska.ac.za

Thys van der Hout

E-mail: thys@solek.co.za

Date: 22 December 2015

Dear Thys,

**Re: Humansrus Solar 3 (Pty) Ltd. Solar PV Development on Farm 147 Humansrus, near Copperton,
Northern Cape Province**

A high level impact assessment was conducted by SKA South Africa on the proposed facility, where it was determined that the proposed facility represented a high risk of detrimental impact to the SKA. A letter confirming this, dated 2nd November 2015, was sent to the respective environmental consultant (Melissa Mackay, Cape Environmental Assessment Practitioners (Pty) Ltd).

This letter follows a teleconference meeting between yourself and SKA South Africa, concerning the development of the proposed facility, and the methodology to conduct an impact assessment on the SKA project.

You indicated the following during the course of the teleconference:

- i. four PV facilities are planned for Humansrus Farm 147, and detailed designs are available for the first two of the four proposed facilities;
- ii. the project sponsor is the same for all four project, and that the detailed design for Humansrus Solar PV 2 Energy Facility (Pty) Ltd can be used as representative of the detailed design for all four facilities;
- iii. Humansrus Solar PV 2 Energy Facility and Humansrus Solar PV 4 Energy Facility are the closest to the SKA receiver (SKA ID 1890), whereas Humansrus Solar PV 3 and Humansrus Solar PV 1 Energy Facilities are the furthest away from the SKA receiver.

Based on the information provided, the following was proposed by yourself:

- i. Suitable EMC consultants are appointed by yourself to conduct a detailed analysis of the detailed designs for Humansrus Solar PV Energy Facility 2;
- ii. The results of the analysis conducted in i. above would be used to conducted a desktop characterisation of the expected radio emissions from Humansrus Solar PV 3 Energy Facility, and interference studies on the SKA would be conducted using site specific information. Consideration shall be given to the cumulative impact of multiple facilities in the vicinity of this facility;



SKA SOUTH AFRICA
SQUARE KILOMETRE ARRAY

-
- iii. Depending on the results of the analysis conducted in ii. above, additional on-site measurements will be conducted, as required by SKA South Africa, for Humansrus Solar PV 2 Energy Facility in order to better inform, and reduce uncertainty, in the characterisation of expected radio emissions from Humansrus Solar PV 3 Energy Facility;
 - iv. Results of the analysis conducted in i., ii. and iii. above will be used by the project developers to quantify and mitigate risks for all four proposed Humansrus Solar PV Energy Facilities.

SKA South Africa views the proposal as being suitable for the purposes of conducting a detailed impact assessment. Should relevant phases of the impact assessment indicate that a high level of risk still remains, SKA South Africa will continue to engage with the developers and relevant EMC Consultant. It remains the responsibility of the developer to ensure that all potential risk is mitigated entirely for the purposes of the Environmental Impact Assessment process.

Regards,

Dr. Adrian Tiplady
Head: Strategy
SKA South Africa
Tel: 011 442 2434
Fax: 011 442 2454
atiplady@ska.ac.za



17 Baker Street
Rosebank
Johannesburg
South Africa
2196

Tel: +27 (0) 11 442 2434
Fax: +27 (0) 11 442 2454
Email: atiplady@ska.ac.za

Melissa Mackay
Senior Consultant
Cape Environmental Assessment Practitioners (Pty) Ltd
P.O. Box 2070
George
Western Cape
6530

E-mail: mel@cape-eaprac.co.za

Date: 02 November 2015

Dear Melissa,

Re: Development of Humansrus 3 Solar PV Energy Facility in the Northern Cape Province.

This letter is in response to your email request, to provide an assessment on the potential development of a photo-voltaic electricity generation facilities in the Northern Cape Province and the risk it may pose on the Square Kilometre Array Project.

A high level risk assessment has been conducted at the South African SKA Project Office to determine the potential impact of such facilities on the Square Kilometre Array. This letter serves to confirm the outcomes of the risk assessment, and proposals for any future investigations associated with this facility.

- I. The location of the proposed facility has been provided in form of Google Earth Shapefile provided by Cape EAPrac,
- II. The nearest SKA station has been identified as SKA station ID 1890, at approximately 15km from the proposed installation;
- III. Based on distance to the nearest SKA station, and the information currently available on the detailed design of the PV installation, this facility poses a **high risk** of detrimental impact on the SKA;
- IV. As a result of the **high risk** associated with the PV facility, the SKA project office requires that further EMI and RFI detailed studies be conducted as significant mitigation measures would be required to lower the risk of detrimental impact to an acceptable level. Until these further studies can be undertaken, the SKA does not support the establishment of this facility, particularly considering the cumulative impact of multiple facilities at the proposed location;
- V. Any transmitters that are to be established, or have been established, at the site for the purposes of voice and data communication will be required to comply with the relevant AGA regulations concerning the restriction of use of the radio frequency spectrum that applies in the area concerned; The South African SKA Project Office would like to be kept informed of progress with this project, and reserves the right to further risk assessments at a later stage.



SKA SOUTH AFRICA
SQUARE KILOMETRE ARRAY

This technical advice is provided by the South African SKA Project Office on the basis of the protection requirements of the SKA in South Africa, and does not constitute legal approval of the renewable energy projects in terms of the Astronomy Geographic Advantage Act, the Management Authority, and its regulations or declarations.

Regards,

Dr. Adrian Tiplady
Head: Strategy
SKA South Africa
Tel: 011 442 2434
Fax: 011 442 2454
atiplady@ska.ac.za



OFFICE OF THE REGIONAL LAND CLAIMS COMMISSIONER: NORTHERN CAPE

4-8 Old Main Road, 4th floor Hyesco Arcade, Kimberley 8300

P.O. Box 2458, Kimberley, 8300

Tel: (053) 807 5700 Fax: (053) 831 6501

Reference: Archibald Mokale

Date: 01/12/2015

APPLICANT: Cape Environmental Assessment Practitioners (pty) Ltd

17 progress street

George

6530

Tel: 044 874 0365

RE: LAND CLAIMS ENQUIRY[S]

PROPERTY[S] DESCRIPTION

- 1 Portion of farm 147 Humansrus Prieska in the Northern Cape Province.**

This communiqué serves to advise your company that according to our database there are no restitution claims lodged against the above mentioned properties description.

We are receiving new restitution claims as of 2014 onwards.

It should however be borne in mind that our database is continuously being updated, therefore this information may be subject to change and you will be informed accordingly.

Yours in service delivery

PP 

Ms. M Du toit

Chief Director: Land Restitution Support-Northern Cape

Date: 01/12/2015

Melissa Mackay

From: John Geeringh <GeerinJH@eskom.co.za>
Sent: 24 November 2015 01:43 PM
To: mel@cape-eaprac.co.za
Subject: RE: Humansrus Solar PV 3 and 4 on Farm 147 Humansrus Prieska
Attachments: Eskom requirements for work in or near Eskom servitudes SOLAR (3).doc;
Renewable Energy Generation Plant Setbacks to Eskom Infrastructure - Signed.pdf

Please find attached Eskom requirements for works at or near Eskom infrastructure.

Regards

John Geeringh (Pr Sci Nat)
Senior Consultant Environmental Management

Eskom GC: Land Development
Megawatt Park
D1Y39
P O Box 1091
Johannesburg
2000

Tel: 011 516 7233
Fax: 086 661 4064
Cell: 083 632 7663

From: Melissa Mackay [<mailto:mel@cape-eaprac.co.za>]
Sent: 19 November 2015 02:50 PM
To: mm@siyathemba.gov.za; johannb@siyathemba.gov.za; thokob@daff.gov.za; bridgetc@ewt.org.za; dekokkr@nra.co.za; Marshall Felaar; John Geeringh; phine@sahra.org.za; hohned@dwa.gov.za; mjh@lantic.net; humanwj@gmail.com; nielj07@vodamail.co.za; juliusg@nra.co.za; koegelenbergj@sentech.co.za; Kevin Leask; slekota@environment.gov.za; jacolinema@daff.gov.za; mashuduma@daff.gov.za; 'Pheladi Masipa'
Cc: ayanda@doc.gov.za; Melanie Miles; tmtho@webmail.co.za; mmboneni.mutheiwana@dmr.gov.za; peter.novellie@sanparks.org; pixley@telkomsa.net; nomawethu.qase@energy.gov.za; energy@birdlife.org.za; TRatlou@environment.gov.za; ntsundeni.ravhugoni@dmr.gov.za; gloriaspeelman.gs@gmail.com; dstander@ncpg.gov.za; strohl@caa.co.za; ratha.timothy@gmail.com; 'Adrian Tiplady'; ntoerien1@gmail.com; Justine Wyngaardt
Subject: Humansrus Solar PV 3 and 4 on Farm 147 Humansrus Prieska

Good afternoon

RE: AVAILABILITY OF PRE APPLICATION SCOPING REPORT FOR HUMANSRUS SOLAR PV 3 & 4

Please find attached notification calling for registration and availability of a Pre Application Scoping Report for the proposed Humansrus Solar PV 3 (SIY402/02) and Humansrus Solar PV 4 (SIY407/02) facilities on portions of Farm 147 Humansrus near Prieska.

Authorities will be provided with CD copies of the Scoping Report. Additional CD copies are available on request. Alternatively the report will be available on the *Cape EAPrac* website from 20 November to 10 December 2015.

Regards

Melissa Mackay | 084 584 7419
SENIOR CONSULTANT | ECO | GIS
8 Tech Nature Conservation (NMMU)

T: 044 874 0365
F: 044 874 0432
17 Progress Street, George
P O Box 2070, George 6530

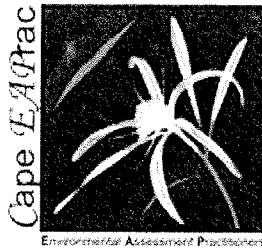

Reduce Reuse Recycle

In the interest of resource conservation please reconsider printing this email.

This message and any attachments to it contains privileged and confidential information intended only for the use of the addressee. If you are not the addressee you are hereby notified that you may not disseminate, copy or take action in respect of its contents. If you have received this message in error please notify Cape EAPrac immediately and return it to the above address. The views expressed in this message are not necessarily the views of Cape EAPrac, its Directors or Staff and no liability is accepted as a result of the contents expressed herein.

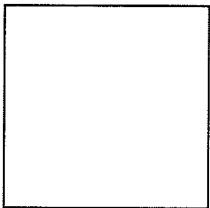

This email has been checked for viruses by Avast antivirus software.
www.avast.com

I'm part of the 49Million initiative...
<http://www.49Million.co.za>

NB: This Email and its contents are subject to the Eskom Holdings SOC Limited EMAIL LEGAL NOTICE which can be viewed at http://www.eskom.co.za/Pages/Email_Legal_Spam_Disclaimer.aspx

Eskom requirements for work in or near Eskom servitudes.

1. Eskom's rights and services must be acknowledged and respected at all times.
2. Eskom shall at all times retain unobstructed access to and egress from its servitudes.
3. Eskom's consent does not relieve the developer from obtaining the necessary statutory, land owner or municipal approvals.
4. Any cost incurred by Eskom as a result of non-compliance to any relevant environmental legislation will be charged to the developer.
5. If Eskom has to incur any expenditure in order to comply with statutory clearances or other regulations as a result of the developer's activities or because of the presence of his equipment or installation within the servitude restriction area, the developer shall pay such costs to Eskom on demand.
6. The use of explosives of any type within 500 metres of Eskom's services shall only occur with Eskom's previous written permission. If such permission is granted the developer must give at least fourteen working days prior notice of the commencement of blasting. This allows time for arrangements to be made for supervision and/or precautionary instructions to be issued in terms of the blasting process. It is advisable to make application separately in this regard.
7. Changes in ground level may not infringe statutory ground to conductor clearances or statutory visibility clearances. After any changes in ground level, the surface shall be rehabilitated and stabilised so as to prevent erosion. The measures taken shall be to Eskom's satisfaction.
8. Eskom shall not be liable for the death of or injury to any person or for the loss of or damage to any property whether as a result of the encroachment or of the use of the servitude area by the developer, his/her agent, contractors, employees, successors in title, and assignees. The developer indemnifies Eskom against loss, claims or damages including claims pertaining to consequential damages by third parties and whether as a result of damage to or interruption of or interference with Eskom's services or apparatus or otherwise. Eskom will not be held responsible for damage to the developer's equipment.
9. No mechanical equipment, including mechanical excavators or high lifting machinery, shall be used in the vicinity of Eskom's apparatus and/or services, without prior written permission having been granted by Eskom. If such permission is granted the developer must give at least seven working days' notice prior to the commencement of work. This allows time for arrangements to be made for supervision and/or precautionary instructions to be issued by the relevant Eskom Manager

Note: Where and electrical outage is required, at least fourteen work days are required to arrange it.

10. Eskom's rights and duties in the servitude shall be accepted as having prior right at all times and shall not be obstructed or interfered with.
11. Under no circumstances shall rubble, earth or other material be dumped within the servitude restriction area. The developer shall maintain the area concerned to Eskom's satisfaction. The developer shall be liable to Eskom for the cost of any remedial action which has to be carried out by Eskom.
12. The clearances between Eskom's live electrical equipment and the proposed construction work shall be observed as stipulated by *Regulation 15 of the Electrical Machinery Regulations of the Occupational Health and Safety Act, 1993 (Act 85 of 1993)*.
13. Equipment shall be regarded electrically live and therefore dangerous at all times.
14. In spite of the restrictions stipulated by Regulation 15 of the Electrical Machinery Regulations of the Occupational Health and Safety Act, 1993 (Act 85 of 1993), as an additional safety precaution, Eskom will not approve the erection of houses, or structures occupied or frequented by human beings, under the power lines or within the servitude restriction area.
15. Eskom may stipulate any additional requirements to highlight any possible exposure to Customers or Public to coming into contact or be exposed to any dangers of Eskom plant.
16. It is required of the developer to familiarise himself with all safety hazards related to Electrical plant.
17. Any third party servitudes encroaching on Eskom servitudes shall be registered against Eskom's title deed at the developer's own cost. If such a servitude is brought into being, its existence should be endorsed on the Eskom servitude deed concerned, while the third party's servitude deed must also include the rights of the affected Eskom servitude.

John Geeringh (Pr Sci Nat)

Senior Consultant Environmental Management
Eskom GC: Land Development

	<p style="text-align: center;">SCOT</p>	<p style="text-align: center;">Technology</p>
---	--	--

Title: **Renewable Energy Generation Plant Setbacks to Eskom Infrastructure** Unique Identifier: **240-65559775**

Alternative Reference Number: **N/A**

Area of Applicability: **Power Line Engineering**

Documentation Type: **Guideline**

Revision: **0**

Total Pages: **8**

Next Review Date: **N/A**

Disclosure Classification: **CONTROLLED DISCLOSURE**

Compiled by



J W Chetty
Mechanical Engineer

Date: 20/02/2014

Approved by



V Naidoo
Chief Engineer (Lines)

Date: 24/02/2014

Authorised by

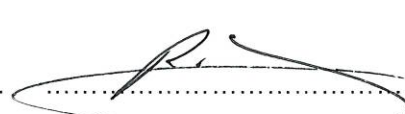

R A Vajeth
Acting Snr Manager (Lines)

Date: 27/2/2014

Supported by SCOT/SC



R Vajeth
SCOT/SC/ Chairperson

Date: 27/2/2014

PCM Reference: 240-65132732 **LINE ENGINEERING SERVICES**

SCOT Study Committee Number/Name : **OVERHEAD LINES**

CONTENTS

	Page
EXECUTIVE SUMMARY	3
1. INTRODUCTION	4
2. SUPPORTING CLAUSES	4
2.1 SCOPE	4
2.1.1 Purpose.....	4
2.1.2 Applicability	5
2.2 NORMATIVE/INFORMATIVE REFERENCES	5
2.2.1 Normative.....	5
2.2.2 Informative	5
2.3 DEFINITIONS	5
2.3.1 Disclosure Classification	6
2.4 ABBREVIATIONS	6
2.5 ROLES AND RESPONSIBILITIES	6
2.6 PROCESS FOR MONITORING	6
2.7 RELATED/SUPPORTING DOCUMENTS	6
3. DOCUMENT CONTENT	6
3.1 INTERNATIONAL SETBACK COMPARISON	6
3.2 ESKOM APPROACH FOR WIND FARMS	7
4. AUTHORISATION	8
5. REVISIONS	8
6. DEVELOPMENT TEAM	9

FIGURES

Figure 1: Horizontal Axis Wind Turbine	8
--	---

CONTROLLED DISCLOSURE

When downloaded from the EDMS, this document is uncontrolled and the responsibility rests with the user to ensure it is in line with the authorised version on the system.

EXECUTIVE SUMMARY

In recent decades, the use of wind turbines, concentrated solar plants and photovoltaic plants have been on the increase as it serves as an abundant source of energy. This document specifies setbacks for wind turbines and the reasons for these setbacks from infrastructure as well as setbacks for concentrated solar plants and photovoltaic plants. Setbacks for wind turbines employed in other countries were compared and a general setback to be used by Eskom was suggested for use with wind turbines and other renewable energy generation plants.

CONTROLLED DISCLOSURE

When downloaded from the EDMS, this document is uncontrolled and the responsibility rests with the user to ensure it is in line with the authorised version on the system.

1. INTRODUCTION

During the last few decades, a large amount of wind turbines have been installed in wind farms to accommodate for the large demand of energy and depleting fossil fuels. Wind is one of the most abundant sources of renewable energy. Wind turbines harness the energy of this renewable resource for integration in electricity networks. The extraction of wind energy is its primary function and thus the aerodynamics of the wind turbine is important. There are many different types of wind turbines which will all exhibit different wind flow characteristics. The most common wind turbine used commercially is the Horizontal Axis Wind Turbine. Wind flow characteristics of this turbine are important to analyse as it may have an effect on surrounding infrastructure.

Wind turbines also cause large turbulence downwind that may affect existing infrastructure. Debris or parts of the turbine blade, in the case of a failure, may be tossed behind the turbine and may lead to damage of infrastructure in the wake path.

This document outlines the minimum distances that need to be introduced between a wind turbine and Eskom infrastructure to ensure that debris and / or turbulence would not negatively impact on the infrastructure.

Safety distances of wind turbines from other structures as implemented by other countries were also considered and the reasons for their selection were noted.

Concentrated solar plants and photovoltaic plants setbacks away from substations were also to be considered to prevent restricting possible power line access routes to the substation.

2. SUPPORTING CLAUSES

2.1 SCOPE

This document provides guidance on the safe distance that a wind turbine should be located from any Eskom power line or substation. The document specifies setback distances for transmission lines (220 kV to 765 kV), distribution lines (6.6 kV to 132 kV) and all Eskom substations. Setbacks for concentrated solar plants and photovoltaic plants are also specified away from substations.

2.1.1 Purpose

Setbacks for wind turbines and power lines / substations are required for various reasons. These include possible catastrophic failure of the turbine blade that may release fragments and which may be thrown onto nearby power lines that may result in damage with associated unplanned outages. Turbulence behind the turbine may affect helicopter flight during routine Eskom live line maintenance and

CONTROLLED DISCLOSURE

When downloaded from the EDMS, this document is uncontrolled and the responsibility rests with the user to ensure it is in line with the authorised version on the system.

inspections that may lead to safety risk of the aircraft / personnel. Concentrated solar plants and photovoltaic plants setback away from substations were required to prevent substations from being boxed in by these renewable generation plants limiting line route access to the substations.

2.1.2 Applicability

This document is applicable to the siting of all new and existing wind turbines, concentrated solar plants and photovoltaic plants near power lines and substations.

2.2 NORMATIVE/INFORMATIVE REFERENCES

2.2.1 Normative

1. <http://www.envir.ee/orb.aw/class=file/action=preview/id=1170403/Hiiumaa+turbulence+impact+EMD.pdf>.
2. <http://www.energy.ca.gov/2005publications/CEC-500-2005-184/CEC-500-2005-184.PDF>
3. <http://www.adamscountywind.com/Revised%20Site/Windmills/Adams%20County%20Ordinance/Adams%20County%20Wind%20Ord.htm>
4. http://www.dsireusa.org/incentives/incentive.cfm?Incentive_Code=PA11R&RE=1&EE=1
5. <http://www.wind-watch.org/documents/european-setbacks-minimum-distance-between-wind-turbines-and-habitations/>
6. <http://www.publications.parliament.uk/pa/ld201011/ldbills/017/11017.1-i.html>
7. http://www.caw.ca/assets/pdf/Turbine_Safety_Report.pdf
8. Rogers J, Slegers N, Costello M. (2011) A method for defining wind turbine setback standards. Wind energy 10.1002/we.468

2.2.2 Informative

None

2.3 DEFINITIONS

Definition	Description
Setback	The minimum distance between a wind turbine and boundary line/dwelling/road/infrastructure/servitude etc.
Flicker	Effect caused when rotating wind turbine blades periodically cast shadows
Tip Height	The total height of the wind turbine ie. Hub height plus half rotor diameter (see Figure1)

CONTROLLED DISCLOSURE

When downloaded from the EDMS, this document is uncontrolled and the responsibility rests with the user to ensure it is in line with the authorised version on the system.

2.3.1 Disclosure Classification

Controlled disclosure: controlled disclosure to external parties (either enforced by law, or discretionary).

2.4 ABBREVIATIONS

Abbreviation	Description
None	

2.5 ROLES AND RESPONSIBILITIES

All personnel involved in the positioning wind turbines, concentrated solar plants and photovoltaic plants near power lines/substations must follow the setbacks outlined in this guideline.

2.6 PROCESS FOR MONITORING

Approval by Eskom in writing.

2.7 RELATED/SUPPORTING DOCUMENTS

None

3. DOCUMENT CONTENT

3.1 INTERNATIONAL SETBACK COMPARISON

Wind Turbine setbacks employed by various countries were considered. It was found that setbacks were determined for various reasons that include noise, flicker, turbine blade failure and wind effects. The distances (setbacks) varied based on these factors and were influenced by the type of infrastructure

Wind turbine setbacks varied for roads, power lines, dwellings, buildings and property and it was noted that the largest setbacks were employed for reasons of noise and flicker related issues [1-7]. Very few countries specified setbacks for power lines.

The literature survey [1-7], yielded information about studies and experiments were conducted to determine the distance that a broken fragment from a wind turbine might be thrown. Even though of low probability of hitting a power line [5.0×10^{-5}]^[8], the distances recorded were significant [750m]^[8]

Setbacks were thus introduced to prevent any damage to Eskom infrastructure.

CONTROLLED DISCLOSURE

When downloaded from the EDMS, this document is uncontrolled and the responsibility rests with the user to ensure it is in line with the authorised version on the system.

Wind turbines may also cause changes in wind patterns with turbulent effects behind the hub. These factors dictate the wind turbine setbacks specified in this document.

Concentrated solar plants and photovoltaic plants also can limit access into the substation for power lines of all voltages. A setback distance must therefore be employed to prevent the substation from being boxed in by these generation plants. These setback distances are specified in this document.

3.2 ESKOM REQUIRED SETBACKS

- Eskom requires a setback distance of 3 times the tip height of the wind turbine from the edge of the closest Eskom servitude (including vacant servitudes) for transmission lines.
- Eskom requires a setback distance of 1 times the tip height of the wind turbine from the edge of the closest Eskom servitude (including vacant servitudes) for distribution Lines.
- Eskom must be informed of any proposed wind turbine, concentrated solar plants and photovoltaic activity within a 5 km radius of a substation. No wind turbine structure shall be built within a 2 km radius of the closest point of the substation. Where concentrated solar plants and photovoltaic structures fall within a 2 km radius of the closest point of a substation, Eskom should be informed in writing during the planning phase of the construction of such plant or structure.
- Applicants must show that Eskom radio telecommunication systems (mainly microwave systems) will not be affected in any way by wind turbines.

CONTROLLED DISCLOSURE

When downloaded from the EDMS, this document is uncontrolled and the responsibility rests with the user to ensure it is in line with the authorised version on the system.

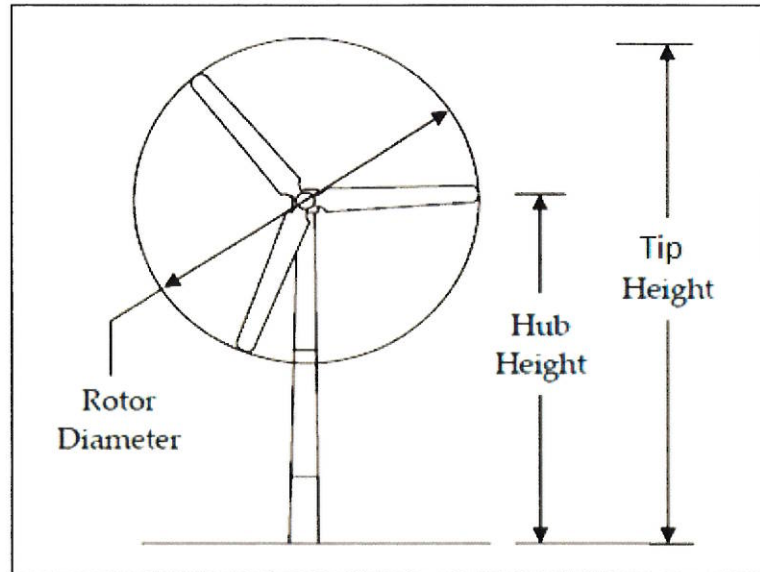

Figure 1: Horizontal Axis Wind Turbine ^[2]

4. AUTHORISATION

This document has been seen and accepted by:

Name & Surname	Designation
V Naidoo	Chief Engineer
Dr P H Pretorius	Electrical Specialist
J Geeringh	Snr Consultant Environ Mngt
B Haridass	Snr Consultant Engineer
R A Vajeth	Acting Snr Manager (Lines)

5. REVISIONS

Date	Rev.	Compiler	Remarks
November 2013	0	J W Chetty	First Publication - No renewable energy generation plant setback specification in existence

CONTROLLED DISCLOSURE

When downloaded from the EDMS, this document is uncontrolled and the responsibility rests with the user to ensure it is in line with the authorised version on the system.

6. DEVELOPMENT TEAM

The following people were involved in the development of this document:

Jonathan W Chetty (Mechanical Engineer)

Vivendhra Naidoo (Chief Engineer)

Dr Pieter H Pretorius (Electrical Specialist)

John Geeringh (Snr Consultant Environ Mngt)

Bharat Haridass (Snr Consultant Engineer)

Riaz A Vajeth (Acting Snr Manager (Lines))

CONTROLLED DISCLOSURE

When downloaded from the EDMS, this document is uncontrolled and the responsibility rests with the user to ensure it is in line with the authorised version on the system.



Cape Environmental Assessment Practitioners (Pty) Ltd

Reg. No. 2008/004627/07
VAT No 4720248386

Telephone: (044) 874 0365
Facsimile: (044) 874 0432

17 Progress Street, George
PO Box 2070, George 6530

Web: www.cape-eaprac.co.za

19 November 2015

Ref: SIY402/02

DEA Ref: To be confirmed

Attention: Stakeholder

VIA: Email, Fax and Post

RE: REQUEST FOR REGISTRATION AND AVAILABILITY OF PRE APPLICATION SCOPING REPORT FOR THE HUMANSRUS 3 SOLAR DEVELOPMENT ON PORTION OF FARM 147 HUMANSRUS, PRIESKA

Cape Environmental Assessment Practitioners (Pty) Ltd. (Cape EAPrac) has been appointed by the Applicant, **Humansrus Solar 3 (Pty) Ltd.**, as independent environmental assessment practitioner (EAP), to facilitate the Scoping & Environmental Impact Reporting (S&EIR) process required in terms of the National Environmental Management Act (NEMA, Act 107 of 1998) and 2014 Regulations for the proposed **Humansrus 3 PV Solar Development, near Prieska** in the Northern Cape.

The Applicant intends to develop a **75MW (megawatt) Photovoltaic (PV) solar power development**, with a footprint of **approximately 220ha**, on Farm 147 Humansrus, located approximately 10km south of the town of Copperton and 50kms west of Prieska. The electricity to be generated by the solar photovoltaic panels will be fed into the national grid via the **existing Kronos Substation**. Associated infrastructure will thus include a **132kV transmission line** (within an existing Eskom servitude), as well as an on-site substation, auxiliary buildings, access and internal roads, perimeter fencing etc.

The procedures for S&EIR process in terms of the 2014 Regulations (R983, R984 & R985) are being followed for this project.

This notification forms part of the Pre Application phase of the Environmental Impact Assessment (EIA) process. A formal Application for Environmental Authorisation will be submitted to the national Department of Environmental Affairs (DEA) once the initial review period has been completed.

As a potential **Stakeholder / Neighbour / Organ of State / State Department**, you are hereby requested to confirm your registration as an Interested & Affected party (I&AP). Furthermore you are hereby notified that the Pre Application Scoping Report (SR) is available for review and comment for a period of 21 days extending from **Friday 20 November to Thursday 10 December 2015**.

Hard copies of the Pre Application Scoping Report have been placed at the following venues for review:

- **Prieska Library** (located on Stewart Street, Prieska)
- **Siyathemba Municipality offices** (located on Victoria Street, Prieska)

Please do not remove these copies from the above venues.

A digital copy of the Pre Application Scoping Report will also be available on the *Cape EAPrac* website at www.cape-eaprac.co.za. Authorities have been provided with digital copies on CD. Additional CDs are available on request.

Please submit your full contact details and any comments you may have to *Cape EAPrac* (contact details below) on or before **10 December 2015**:

Cape EAPrac		
ATTN: Ms Melissa Mackay		
P.O. Box 2070, George, 6530	Tel: 044 874 0365	Fax: 044 874 0432
E-mail: mel@cape-eaprac.co.za		

Upon closing of the 21-day comment period, comments received will be considered and feedback provided, after which the comments and responses will be included in the formal Scoping Report (SR). The review period of the formal SR will be provided to all registered I&APs. Please note that only registered stakeholders will be kept informed throughout the remainder of the environmental process.

If you require any further assistance, please do not hesitate to contact this office directly.

Kind regards,

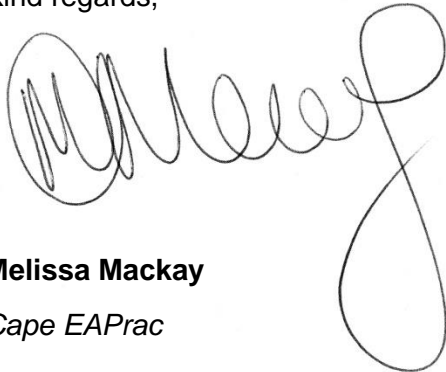

Melissa Mackay

Cape EAPrac

Registration, Review & Comment Period:
Friday 20 November to Thursday 10 December 2015.

Melissa Mackay

From: Melissa Mackay <mel@cape-eaprac.co.za>
Sent: 19 November 2015 02:50 PM
To: 'mm@siyathemba.gov.za'; 'johannb@siyathemba.gov.za'; 'thokob@daff.gov.za'; 'bridgetc@ewt.org.za'; 'dekokkr@nra.co.za'; 'felaarmb@eskom.co.za'; 'geerinjh@eskom.co.za'; 'phine@sahra.org.za'; 'hohned@dwa.gov.za'; 'mjh@lantic.net'; 'humanwj@gmail.com'; 'nielj07@vodamail.co.za'; 'juliusg@nra.co.za'; 'koegelenbergj@sentech.co.za'; 'leaskk@eskom.co.za'; 'slekota@environment.gov.za'; 'jacolinema@daff.gov.za'; 'mashuduma@daff.gov.za'; 'Pheladi Masipa'
Cc: 'ayanda@doc.gov.za'; Melanie Miles (MelanieM@L2B.co.za); 'tmtho@webmail.co.za'; 'mmboneni.mutheiwana@dmr.gov.za'; 'peter.novellie@sanparks.org'; 'pixley@telkomsa.net'; 'nomawethu.qase@energy.gov.za'; 'energy@birdlife.org.za'; TRatlou@environment.gov.za; 'ntsundeni.ravhugoni@dmr.gov.za'; 'gloriaspeelman.gs@gmail.com'; 'dstander@ncpg.gov.za'; 'strohl@caa.co.za'; 'ratha.timothy@gmail.com'; 'Adrian Tiplady'; 'ntoerien1@gmail.com'; 'Justine Wyngaardt'
Subject: Humansrus Solar PV 3 and 4 on Farm 147 Humansrus Prieska
Attachments: SIY402.02 SR Notification Nov15.pdf; SIY407.02 SR Notification 19Nov15.pdf

Good afternoon

RE: AVAILABILITY OF PRE APPLICATION SCOPING REPORT FOR HUMANSRUS SOLAR PV 3 & 4

Please find attached notification calling for registration and availability of a Pre Application Scoping Report for the proposed Humansrus Solar PV 3 (SIY402/02) and Humansrus Solar PV 4 (SIY407/02) facilities on portions of Farm 147 Humansrus near Prieska.

Authorities will be provided with CD copies of the Scoping Report. Additional CD copies are available on request. Alternatively the report will be available on the *Cape EAPrac* website from 20 November to 10 December 2015.

Regards

Melissa Mackay | 084 584 7419
SENIOR CONSULTANT | ECO | GIS
B.Tech Nature Conservation (NMMU)

T: 044 874 0365
F: 044 874 0432
17 Progress Street, George
P O Box 2070, George 6530

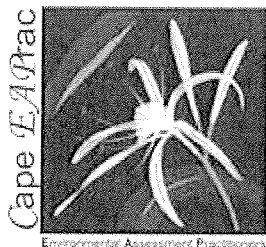

Reduce Reuse Recycle

In the interest of resource conservation please reconsider printing this email.

This message and any attachments to it contains privileged and confidential information intended only for the use of the addressee. If you are not the addressee you are hereby notified that you may not disseminate, copy or take action in respect of its contents. If you have received this message in error please notify Cape EAPrac immediately and return it to the above address. The views expressed in this message are not necessarily the views of Cape EAPrac, its Directors or Staff and no liability is accepted as a result of the contents expressed herein.

Send Result Report

MFP

TASKalfa 250ci

Firmware Version 2H7_2F00.013.006 2012.01.06

20/11/2015 12:44
[2JZ_1000.024.001] [2H7_1100.002.003] [2H7_7000.013.006]

Job No.: 008447

Total Time: 0°03'49"

Page: 004

Error occurred

Document: **doc20151120123429**

No.	Date and Time	Destination	Times	Type	Result	Resolution/ECM
001	20/11/15 12:34	0543378001	0°02'09"	FAX	BUSY	200x100 Normal/Off
002	20/11/15 12:35	0538316501	0°01'07"	FAX	OK	200x100 Normal/On
003	20/11/15 12:37	0538077328	0°00'33"	FAX	OK	200x100 Normal/On



Cape EAPrac

OPENBARE DEELNAMEPROSES

Registrasie van Belanghebbende & Geaffekteerde Partye
Humansrus 3 & 4 PV Sonkrag Ontwikkeling suid-wes van Prieska

Heermee word kennis gegee van 'n Openbaredeelnameproses in terme van die Wet op Nasionale Omgewingsbestuur (Nr 107 van 1998) en die Wet op Nasionale Erfenishulbronne (Nr 25 van 1999).

“n Omvangsbepaling & Omgewingsinvloedbepalingsproses (O&OIB) is by die nasionale Departement van Omgewingsake (DO) as die besluitnemende owerheid geïnisieer.

Projek:	Humansrus 3 Sonkrag Ontwikkeling	Humansrus 4 Sonkrag Ontwikkeling
DO Verwysing:	Om te bevestig	Om te bevestig
Aansoeker:	Humansrus 3 Solar (Pty) Ltd	Humansrus 4 Solar (Pty) Ltd
Ligging:	Geddelte van Plaas 147 Humansrus, geleë langs op die R357, suid-wes van Prieska in die Noordkaap.	
Voorstel:	Ontwikkeling van 'n 75MW (megawatt) Fotovoltaise (PV) Aanleg, met verwante infrastruktuur: op-terrein substasie, geboue, toegang en interne paaie, oorhoofse elektriese kraglyn na die Kronos Eskom-substasies, omheining ens.	Ontwikkeling van 'n 75MW (megawatt) Fotovoltaise (PV) Aanleg, met verwante infrastruktuur: op-terrein substasie, geboue, toegang en interne paaie, oorhoofse elektriese kraglyn na die Kronos Eskom-substasies, omheining ens.
Kwytskelding / Afwyking:	Geen	
B e s k i k b a r e dokumente:	Konsep Omvangsbeplaignsverslag SIY402/01	Konsep Omvangsbeplaignsverslag SIY407/01
Gelyste Aktiwieteite	GN R983: 12(x)&(xi) & 19(i) GN R984: 1 & 15 GN R985: 18(a)(ii) & (iii)	GN R983: 12(x)&(xi) & 19(i) GN R984: 1 & 15 GN R985: 18(a)(ii) & (iii)
Advertensie:	Noordwester Vrydag 20 November 2015	

Om as 'n Belanghebbende en Geaffekteerde Party (B&GP) te registreer, word individue versoek om op hierdie kennisgewing te reageer, deur hul volledige kontakbesonderhede en enige kommentaar aan Cape EAPrac skriftelik te stuur (na onderstaande adres) voor **10 Desember 2015**. Aanlynregistrasievorms en dokumente is beskikbaar op die Cape EAPrac webtuiste: www.cape-eaprac.co.za

Korrespondensie rakend die res van die omgewingproses sal slegs aan geregistreerde B&GP versprei word.

Cape EAPrac (Vir aandag: Mej. Melissa Mackay)

Posbus 2070 George 6530

Telefoon: 044 874 0365 Faks: 044 874 0432

Epos: mel@cape-eaprac.co.za

'n 21-DAE REGISTRASIE EN KOMMENTAAR PERIODE WORD TOEGELAAT, REGISTRASIE VERSOEKE EN KOMMENTAAR MOET SKRIFTELIK INGEDIEN WORD VOOR OF OP DINSDAG, 10 DESEMBER 2015.

LUTZ EN BENECKE SE DAGBOEKE

Dertien dae met ossewa op pad

WILLISTON – Danksy die ywer van Aubrey Herbst, 'n bekende oud-inwoner van

Williston is toegang verkry tot die dagboeke van J. H. Lutz en Beinecke, die Duitse sendelinge wat deur die Rynse Sendinggenootskap van Ebenezer (waarskynlik naby Lutzville) gestuur is om 'n sendingstasie in die omgewing van Williston te begin.

Aubrey kon die dagboek in 'n argief in Duitsland opspoor en dit is uit die gotiese skrif oorgeskryf met behulp van sy vrou, Francky. Elsa van Schalkwyk van Williston het dit uit die Duits vertaal sodat almal dit nou in Afrikaans kan lees.

Min mense in die moderne en haastige tyd waarin ons leef kan 'n beeld vorm van die twee sendelinge en hul geselskap se reis per ossewa in die tydperk November tot Desember 1845 voor hul aan-koms in Amandelboom.

Hy beskryf die roete van Ebenezer so:

Van Ebenezer na Vredendal – 7 uur, 1 dagreis.

Van Vredendal na Trutru – 5 uur, 1 dagreis.

Van Trutru na Kleinfontein – 14 uur, 1 dagreis.

Van Kleinfontein na Zwellegrebel – 4 uur, 1 dagreis.

Van Zwellegrebel na Bokfontein – 4 uur, 1 dagreis.

Van Bokfontein na Matjiesfontein – 10 uur, 1 dagreis.

Van Matjiesfontein na Zoetwater – 7 uur, 1 dagreis.

Van Zoetwater na Ramskop – 16 uur, 2 dagreis.

Van Ramskop na Dounis – 4 uur, 1 dagreis.

Van Dounis na Koppieskraal – 14 uur, 1 dagreis.

Van Koppieskraal na Zakrivier – 12 uur, 1 dagreis.

Van Zakrivier na Amandelboom – 6 uur, 1 dagreis.

Die hele reis het 103 ure en 13 dae geduur.

Soos verlede week deur mev. Marie van Wyk beskryf het hul oral langs die pad bekende

plase en inwoners ont-moet wies nageslagte nou nog hier woon en wat sorg vir interessante leesstof.

Hul doel was om hul op Grootfontein te vestig, waar hul vernem het die sterkste fontein in die Kareberge was. Weens die droogte is hul ingelig dat hul dit nrens beter sal tref as net daar in Amandelboom nie. Die twee het dus daar gebly waar daar reeds vier huisgesinne was.

Sondag 16 November 1845 was die tent waarin hul hul eerste diens gehou het, heetmal vol met die ongeveer dertig kerkgangers.

Die aankoms van die twee sendelinge was die begin van die georganiseerde kerk en skool op Williston.

Uit die dagboeke blyk dat die eerste bousteen vir die stigting van die dorp geen maklike taak was nie en dat enorme offerings gemaak moes word.

Daarom voel die inwoners dat dit gepas is om nou 170 jaar later 'n omblik stil te staan en hulde te bring aan die pioniers.

NWB KRIEKET

BY Laerskool Calvinia se prysoördeling Donderdag 5 November 2015 het hierdie seuns pryse ontvang vir hul opname in NWB kriketspanne. De Wet Rabe (S/13); Alex Voerus (S/12); Roelof du Plessis (S/13); Jody Barend (S/12); Wessel de Lange (S/12); C.J. Festus (S/12); Jean-Priur du Plessis (S/11) en Alex Louw (S/12).

DORSBAK EN DIE SESTIEN DONKIES

Meer masjien en minder mens

Geagte Leser,

Verandering hou nooit op nie. Dit was ook die geval met koringproduksie in ons area. Tegnologie het dit moontlik gemaak vir bestaansboerdery om plek te maak vir kommersiële boerdery.

Aanvanklik is die landjies langs die rivier natgemaak wanneer die rivier loop. Die water is uit die rivier op te stuit met 'n grondwal deur die rivier se loop gemaak is en het bekend gestaan as 'n blokdam. Om te verhoed dat die water skade op die landerye veroorsaak, is die situasie dop gehou. Sodra daar genoeg water op die land was, is die grondwal gestee en het dit weggespoel. Volgende jaar moes 'n nuwe wal gemaak word.

Dit kon nie so aanhou nie. Die blokdam is vervang met 'n stuwal van sement. Die water kon nou beheer word en kon baie meer landerye natgemaak word.

Intussen is die sekel vervang

met die selfbinder wat self gesny en die gerwe gebind het. Die gerwe is nog steeds in 'n mied gepak, maar die dorsvloer het plek gemaak vir die dorsmasjien wat aanvanklik aangedryf is deur 'n stoommasjien, maar later deur 'n trekker.

Die dorsmasjien was 'n swaar implement. Nie alle plase kon 'n dorsmasjien regverdig nie. Dit het beteken dat die masjien geskuif moes word van plaas tot plaas. Vir hierdie taak kon perde nie gebruik word nie. 'n Perd se geardheid was nie reg daarvoor nie. Wanneer 'n perd teen die borsplaat kom, wil hy voel dat dit wat hy trek, beweeg. As dit nie gebeur nie staan hy terug.

Die dorsbak was te swaar en het 'n spesiale gesamentlike poging geverg. Daarvoor was die donkie meer geskik. Tot sestien donkies is voor die dorsbak ingespan. Om 'n gesamentlike poging te verskerk, is die donkies aanstoot gegee totdat almal styf teen die borsplaat gelê het. Dan het 'n man met die beste stem 'n harde "Trek" geskreue. As jy gelukkig was, het die dorsbak in beweging gekom.

Die koring is in sakke opgevang. Hierdie sakke is na die stoor verskuif waar dit gewig gemaak is. Dit het beteken die sak word op 'n platformskaal geplaas. Koring word met die hulp van 'n "skop" bygeskep of uitgeskep. Daardie tyd was die standaardgewig 203 pond (ongeveer 92kg). Die drie pond was vir die gewig van die bekende goingsak (streesak).

Die fisiese betrokkenheid van mens en dier het al minder geraak. Meganisasie het al minder arbeid geverg en hoër produksie moontlik gemaak. Die trekker het die perd vervang. Die stroper het die dorsbak verplaas. Weldra is die koring nie meer gesak nie maar in losmaat na die silo vervoer.

Ten spyte van hierdie aanpassings, het die omvang van koringproduksie afgeneem. Dit het duidelik geword dat skaapboerdery beter betaal en aldus is koring verplaas met lusern en hawer. Op lang termyn bly skaap koning in Calvinia.

Groete, Japie.

32 Jaar gelede

Die NOORDWESTER: 18 November 1983. 'n Organisme bekend as Acinetobacter, onbekend in hierdie geweste was in Brandvlrei verantwoordelik dat 'n hele aantal van mnr. Alwyn Burger van Avondrust se dorperlammers doodgebore is. Dieselfde organisme is in die USA gevind waar dit ook aborsie onder perde en beeste veroorsaak het.

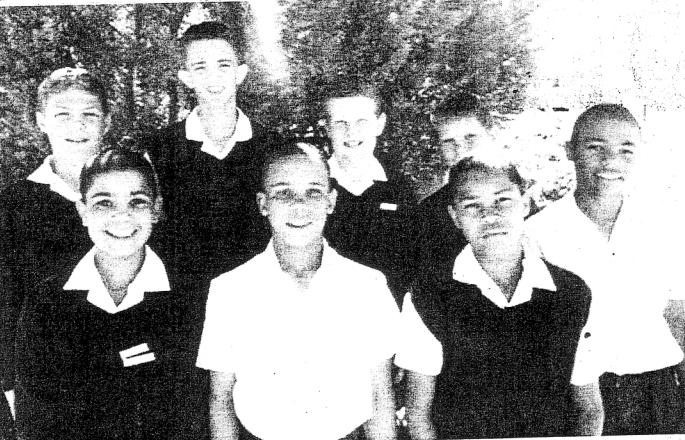

GB KEMPEN & DE WET NEL se Veiling

SATERDAG 28 NOVEMBER 2015 OM 10:00 TE SKOUSTRAT 9, CARNARVON

Behoorlik daartoe gemagtig deur Mnr. WF Immelman en ander verkopers, word die volgende op bogenoemde datum en plek, per openbare veiling aangebied.

MEUBELS EN ALLERIE

3 Enkelbeddens, Kamerstel (dubbelbed + hangkas + speieikas + stoel + bedkas), Imbuia kamerstel (dubbelbed + speieikas + stoel + bedkas + 2 hangkaste), Dubbelbed, Imbuia sitkamerstelsel (3-bank + 4 stoele) met koffietafel, 4 sitkamerstoele, 2 x Hangkaste, 2 x 3-deur kombuiskas, 2 x Bedkasties, Speieikas, Wankis, TV-kabinet, Draadtabel, 4 koffietafels, Glasbad tafel, Ronde tafels, 2 Opvou tafels, Groot paneelte tafel, Groot paneelte tafel met vier hout stoele, 6 x Plastiese stoele, 2 x Oudtydse houtstoele, Opvou stoele, Zopvone seilstoele, skietstoele, Kelvinator dubbelbalie wasmasjien, Kelvinator dubbeldeur yskas, Kelvinator kisvrieskas, Dafy kisvrieskas, Kenwood liquidizer, Kenwood Chef met toebehoere, Mikrogrillfond, Breekgoed, Kombuisware, Werktafel met skroef, Heyco sokkietstel, Boor met staander, Benchgrinder, Southern Cross elektriese grassnyer, Trolley jack, Stampblok en stamp, Boomsput, Columbus polisher (3-borsel), Net Power 6.5 inch generator, Kruwa, Elektriese motors, 2x Traplere, Gereedskap, Tuingeredschap, Gereedschapkassie, Fuchsware TV-stel, Staans haardroër, Elektriese haarknipper, Empial naaimasjien in kas, 2x Waaiers, Koper en ornamente, Muurbanghelsel en prente, Losmatte, Wynvaatlje, Erde waskom, Gang spieël, Oudtydse skaaf en skoenleeste, Phillips radiogram, Verwarmers, Stofsuler, Portretreier, Winkelrolle, Vleisbakke, Gasbraaier, Meat-omatic vleissaag met meul, Worsstopper, 3kg Gassilinder, 3-beempot, Gecado-27 No 1 windgeweer, Potplante, Linnenware & Handdoeke, Kiere + skoenne + hangers, 215 x 15 bakkie buiteland.

TERME: Besigtiging op dag van veiling. Streng kontant of bankgewaarborgde tjek op dag van veiling.

GB KEMPEN & DE WET NEL

Victoriastraat 9, Posbus 4, Carnarvon, 8925 Tel: 053 3823 011
Kontak afslaer vir enige navrae.

Cape EAPrac

OPENBARE DEELNAMEPROSES

Registrasie van Belanghebbende & Geaffekteerde Partye Humansrus 3 & 4 PV Sonkrag Ontwikkeling-suid-wes van Prieska

Hiermee word kennis gegee van 'n Openbaredeelnamesproses in terme van die Wet op Nasionale Omgewingsbestuur (Nr 107 van 1998) en die Wet op Nasionale Erfenisulphronne (Nr 25 van 1999)

'n Omgangsbepaling & Omgewingsinvloedbepalingsproses (O&OIB) is by die Nasionale Departement van Omgewingsake (DO) as die besluitnemende owerheid geteiniseer.

Projek:	Humansrus 3 Sonkrag Ontwikkeling	Humansrus 4 Sonkrag Ontwikkeling
DO Verwysing:	Om te bevestig	Om te bevestig
Aansoeker:	Humansrus 3 Solar (Pty) Ltd	Humansrus 4 Solar (Pty) Ltd
Ligging:	Gedeelte van Plaas 147 Humansrus, geleë langs op die R357, suid-wes van Prieska in die Noord-Kaap.	
Voorstel:	Ontwikkeling van 'n 75MW (megawatt) Fotovoltaïese (PV) Aanleg, met verwante infrastruktuur op-terreïn substasie, geboue, toegang en interne paaië, oorspronke elektriese kraglyn na die Kronos Eskom-substasies, omheining ens.	Ontwikkeling van 'n 75MW (megawatt) Fotovoltaïese (PV) Aanleg, met verwante infrastruktuur op-terreïn substasie, geboue, toegang en interne paaië, oorspronke elektriese kraglyn na die Kronos Eskom-substasies, omheining ens.
Kwytstelling / Afwyking:	Geen	
Beskikbare dokumente:	Konsep Omgangsbepalingsverslag SIY 402/01	Konsep Omgangsbepalingsverslag SIY 407/01
Gelyste Aktiwiteite:	GN R983: 12 (x) & (xi) & 19 (i) GN R984: 1 & 15 GN R985: 18 (a) (ii) & (iii)	GN R983: 12 (x) & (xi) & 19 (i) GN R984: 1 & 15 GN R985: 18 (a) (ii) & (iii)
Advertensie:	Noordwester Vrydag 20 November 2015	

Om as Belanghebbende en Geaffekteerde Party (B&G) te registreer, word individue versoek om op hierdie kennisgewing te reageer, deur hul volledige kontakbesonderhede en enige kommentaar aan Cape EAPrac skriftelik te stuur (na onderstaande adres) voor **10 Desember 2015**. Aanlynregistrasievorms en dokumente is beskikbaar op die Cape EAPrac webtuiste: www.cape-eaprac.co.za

Korrespondensie rakend die res van die omgewingsproses sal slegs aan geregistreerde B&G versprei word.

Cape EAPrac (Vir aandag: Mej. Melissa Mackay)

Posbus 2070, George 6530

Telefoon: 044 874 0365 Faks: 044 874 0432

Epos: mel@cape-eaprac.co.za

'N 21 DAE REGISTRASIE EN KOMMENTAAR PERIODE WORD TOEGELAAT, REGISTRASIE VERSOEKE EN KOMMENTAAR MOET SKRIFTELIK INGEDIEN WORD VOOR OF OP DINSDAG, 10 DESEMBER 2015



Cape Environmental Assessment Practitioners (Pty) Ltd

Reg. No. 2008/004627/07

Telephone: (044) 874 0365
Facsimile: (044) 874 0432

17 Progress Street, George
PO Box 2070, George, 6530

Web: www.cape-eaprac.co.za

19 November 2015
Ref: SIY402/03

Dear Dalene
Prieska Main Library

Via: Courier

RE: PUBLIC DOCUMENT for PUBLIC REVIEW for 21-days

Please could you make this document, Pre Application Scoping Report, Humansrus Solar PV Facility 3, available for public review for a period of 21 days extending from **Friday 20 November to Tuesday 10 December 2015**.

Please could you ensure that this document is NOT REMOVED from the Library during this time period.

Another hard copy of this report has been placed at:

- **Siyathemba Municipality Offices** (located on Victoria Street, Prieska)

Please inform members of the public that a digital copy of the Pre Application Scoping Report will also be available on the *Cape EAPrac* website at:

www.cape-eaprac.co.za

If you require any further assistance, please do not hesitate to contact this office directly.

Kind regards,

Melissa Mackay
For Cape EAPrac

Review Period:

Friday 20 November to Tuesday 10 December 2015.



Cape Environmental Assessment Practitioners (Pty) Ltd

Reg. No. 2008/004627/07

Telephone: (044) 874 0365
Facsimile: (044) 874 0432

17 Progress Street, George
PO Box 2070, George, 6530

Web: www.cape-eaprac.co.za

19 November 2015
Ref: SIY402/04

Dear Reception / Registry
Siyathemba Local Municipality

Via: Courier

RE: PUBLIC DOCUMENT for PUBLIC REVIEW for 21-days

Please could you make this document, Pre Application Scoping Report, Humansrus Solar PV Facility 3, available for public review for a period of 21 days extending from **Friday 20 November to Tuesday 10 December 2015.**

Please could you ensure that this document is NOT REMOVED from the Municipal Offices during this time period.

Another hard copy of this report has been placed at:

- **Prieska Library** (located on Stewart Street, Prieska)

Please inform members of the public that a digital copy of the Draft Scoping Report will also be available on the *Cape EAPrac* website at:

www.cape-eaprac.co.za

If you require any further assistance, please do not hesitate to contact this office directly.

Kind regards,

Melissa Mackay
For Cape EAPrac

Review Period:

Friday 20 November to Tuesday 10 December 2015.



DPD LASER

0861 223 224

www.dawnwing.co.za



1265538481

WAYBILL

Sender to complete yellow areas only

FROM: CAPE TOWN		Contents: DOCUMENTS		HAZARDOUS YES <input type="checkbox"/> NO <input type="checkbox"/>		Filing Ref:	
Address: 17 PROGRESS STR GEORGE		PARCEL DETAILS		SERVICE (mark only one)			
City/Country: RSA		No. of Parcels: 1		Vol(kg)- T's & C's Apply*		Overnight Express	
Postal Code: 6529		Dimensions (cm): L 32 W 21 H 1		Mass(kg)- T's & C's Apply*		Economy Cargo	
Senders Name: MEUSSA MACOM		City/Country: RSA		Postal Code: 8940		Domestic Road Freight	
Phone: 044 8740365		City/Country: RSA		Postal Code: 8940		Sameday Express	
TO: PRIESKA LIBRARY		Dawn Wing reserves the right to mark the service "Overnight Express" should no service level be selected		SPECIAL INSTRUCTIONS			
Street Address (P.O. Box Addresses not accepted): STEWART STR PRIESKA		Terms strictly 30 days from date of statement		Tick to select limited liability option (to a maximum amount of R50 000) for non-excluded articles <input type="checkbox"/>			
City/Country: RSA		CASH AMOUNT R		PAID YES <input type="checkbox"/> NO <input type="checkbox"/>		Customs Value ZAR	
Receiver's Name: DAUENE		Special Instructions		Value of Article ZAR		Account to be Debited	
Phone: 053 353 5305		By signing this waybill the sender is concluding a contract with Dawn Wing and warrants his authority to enter into this contract and to bind the entity, which he/she represents (if any). The terms and conditions of this contract are contained on the reverse of the sender's copy.		Sender's Ref. / Bag No. 402/407		RECEIVED IN GOOD ORDER AND CONDITION	
Senders Name: MEUSSA MACOM		Date: 2011/10/10		Collected By Courier: Cien		Receivers Signature:	
Signature: [Signature]		Time: [Time]		Time: [Time]		Print Name:	
Date: [Date]		Time: [Time]		Date: [Date]		Time: [Time]	

DAWN WING A Division of DPD Laser Express Logistics (Pty) Ltd Reg. No. 2006/033353/07 VAT No. 4690235280 FSP No. 32010

*All weight and dimensions subject to verification through electronic weight and dimension machine (SABS calibrated)

SENDER'S COPY



DPD LASER

0861 223 224

www.dawnwing.co.za



1265538492

WAYBILL

Sender to complete yellow areas only

FROM: CAPE TOWN		Contents: DOCUMENTS		HAZARDOUS YES <input type="checkbox"/> NO <input type="checkbox"/>		Filing Ref:	
Address: 17 PROGRESS STR GEORGE		PARCEL DETAILS		SERVICE (mark only one)			
City/Country: RSA		No. of Parcels: 1		Vol(kg)- T's & C's Apply*		Overnight Express	
Postal Code: 6529		Dimensions (cm): L 32 W 21 H 1		Mass(kg)- T's & C's Apply*		Economy Cargo	
Senders Name: MEUSSA MACOM		City/Country: RSA		Postal Code: 8940		Domestic Road Freight	
Phone: 044 8740365		City/Country: RSA		Postal Code: 8940		Sameday Express	
TO: SIMATHEMBA MUNICIPALITY		Dawn Wing reserves the right to mark the service "Overnight Express" should no service level be selected		SPECIAL INSTRUCTIONS			
Street Address (P.O. Box Addresses not accepted): VICTORIA STREET PRIESKA		Terms strictly 30 days from date of statement		Tick to select limited liability option (to a maximum amount of R50 000) for non-excluded articles <input type="checkbox"/>			
City/Country: RSA		CASH AMOUNT R		PAID YES <input type="checkbox"/> NO <input type="checkbox"/>		Customs Value ZAR	
Receiver's Name: RECEPTION		Special Instructions		Value of Article ZAR		Account to be Debited	
Phone: 053 353 5317		By signing this waybill the sender is concluding a contract with Dawn Wing and warrants his authority to enter into this contract and to bind the entity, which he/she represents (if any). The terms and conditions of this contract are contained on the reverse of the sender's copy.		Sender's Ref. / Bag No. 402/407		RECEIVED IN GOOD ORDER AND CONDITION	
Senders Name: MEUSSA MACOM		Date: 2011/10/15		Collected By Courier: Cien		Receivers Signature:	
Signature: [Signature]		Time: [Time]		Time: [Time]		Print Name:	
Date: [Date]		Time: [Time]		Date: [Date]		Time: [Time]	

DAWN WING A Division of DPD Laser Express Logistics (Pty) Ltd Reg. No. 2006/033353/07 VAT No. 4690235280

*All weight and dimensions subject to verification through electronic weight and dimension machine (SABS calibrated)

SENDER'S COPY

Humansrus Solar PV Facility 3
Pre Application Scoping Report - Postage of CD

Company	FirstName	Surname	PostalAddress1	PostalAddress2	City	PostalCode
Birdlife Africa	Samantha	Ralston	Private Bag X5000	Parklands	Johannesburg	2121
DEA: Directorate of Biodiversity & Conservation	Seoka	Lekota	Private Bag X447		Pretoria	0001
DEA: Directorate of Biodiversity & Conservation	Tumelo	Ratlou	Private Bag X447		Pretoria	0001
Department of Agriculture, Forestry & Fisheries	Thoko	Buthelezi	Private Bag X120		Pretoria	0001
Department of Agriculture, Forestry & Fisheries	Jacoline	Mans	P.O. Box 2782		Upington	8800
Department of Agriculture, Forestry & Fisheries	Mashudu	Marubini	Private Bag X120		Pretoria	0001
Department of Agriculture, Forestry & Fisheries	Nico	Torien	P.O. Box 52		Upington	8800
Department of Communications	Ayanda	Mbolekwa	Private Bag X860	Pretoria	Pretoria	0001
Department of Energy	Pheladi	Masipa	Private Bag X96		Pretoria	0001
Department of Mineral Resources	Mmboneni Kevin	Mutheiwana	Pvt Bag X6093		Kimberley	8300
Department of Mineral Resources	Ntsundeni	Ravhugoni	Private Bag X 6093		Kimberley	8300
Department of Minerals and Energy	Noma	Qase	Private Bag X 19	Arcadia	Arcadia	0007
Department of Rural Development & Land Reform	Motebang	Ranchobe Ranchobe	PO Box 2458		Kimberley	8300
Department of Science & Technology	Adrian	Tiplady	P.O. Box 522940	Rosebank	Johannesburg	2132
Dept. Water Affairs: Northern Cape	Danita	Hohne	Pvt Bag X5912		Upington	8800
Endangered Wildlife Trust (EWT)	Bridget	Corrigan	Pvt Bag X11	Modderfontein	Johannesburg	1645
ESKOM	John	Geeringh	P.O. Box 1091		Johannesburg	2000
ESKOM	Kevin	Leask	P.O. Box 1091		Johannesburg	2000
ESKOM	Ronald	Marais	P.O. Box 1091		Johannesburg	2000
ESKOM Distribution - Western Operating Unit	Marshall	Felaar	P.O. Box 222		Brackenfell	7561
ESKOM Distribution - Western Operating Unit	Justine	Wyngaardt	P.O. Box 222		Brackenfell	7561
North Cape Department of Environmental Affairs	Denver	van Heerden	Private Bag X6102		Kimberley	8301
Northern Cape Department of Environment and Nature Conservation	Thulani	Mthombeni	Private Bag X6102		Kimberley	8300
Northern Cape Department of Health	Danie	Stander	Private Bag X 5049		Kimberley	8300
Pixley ka Seme District Municipality	Rodney	Pieterse	Private Bag X1012		De Aar	7000
Provincial Roads	Niel	Joubert	Pastorie Street, NDM Building		Calvinia	8190
SAHRA	Phillip	Hine	P.O. Box 4637		Cape Town	8000
SANRAL	Rene	De Kock	Private Bag X19		Bellville	7535
SANRAL	Garth	Julius	Private Bag x 19	Bellville	Cape Town	7535
SENTECH	Johan	Koegelenberg	Octave Road	Radiokop	Roodepoort	1724
Siyathemba Local Municipality	John	Alexander	P.O. Box 16		Prieska	8940
Siyathemba Local Municipality	Johan	Badenhorst	P.O. Box 16		Prieska	9840
Siyathemba Local Municipality	Gloria	Speelman	P.O. Box 16		Prieska	8940
South African Civil Aviation Authority	Lizelle	Stroh	Private Bag X73	Halfway House	Johannesburg	1685
South African National Parks	Peter	Novellie	P.O. Box 787		Pretoria	0001

Cape EAPrac
P.O. Box 2070 / George 6530
17 Progress Street
Tel: 044 874 0365 Fax: 044 874 0432
Web: www.cape-eaprac.co.za



Cape EAPrac
P.O. Box 2070 / George 6530
17 Progress Street
Tel: 044 874 0365 Fax: 044 874 0432
Web: www.cape-eaprac.co.za

SM 402/407



Von Wyk Braers
Po Box 217
Prieska
8940

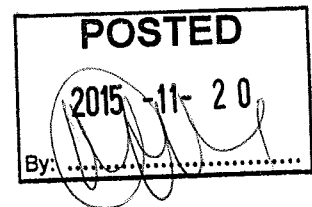

SM 402/407

Mbawu Mining (Pty) Ltd
Cedar Roc Langveldt Street 61
Midrand
1864

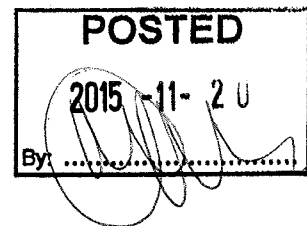

Cape EAPrac
P.O. Box 2070 / George 6530
17 Progress Street
Tel: 044 874 0365 Fax: 044 874 0432
Web: www.cape-eaprac.co.za

SM 402/407



A de Jager
PO Box 233
Preston
8940

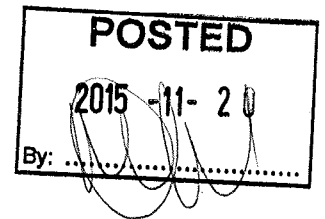

SM 402/407



W. Fanie
PO Box 382
Preston
8940

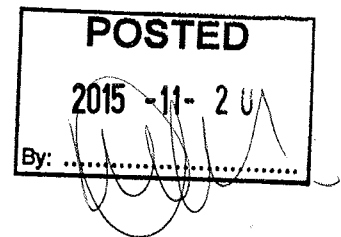

Appendix C: Site Photographs



Photo A: Site notice adjacent to the R357 showing northern area of property.
Photo B: Site notice details.



Photo C: Site notice adjacent to the R357 showing southern area of property.
Photo D: Site notice details.

