

SUMMARY TABLE	
DESCRIPTION	TOTAL NUMBER/AREA
ADULT GRAVE SITES	3662
CHILD GRAVE SITES	3662
PARKING BAYS	27
DISABLED PARKING BAYS	5
TOTAL FENCED AREA	65 743.62 m ²

NOTE:
A WULA IS REQUIRED PRIOR TO CONSTRUCTION OF PIPELINE OUTLET INTO WATER COURSE

BOUNDARY PEGS		
NAME	X - COORDINATE	Y - COORDINATE
1	-322877.31	38777.50
2	-322878.15	38779.09
3	-3228833.49	38761.81
4	-3228837.12	38770.23
5	-3228870.78	38781.78
6	-3228902.05	38781.95
7	-3228943.51	38770.05
8	-3228940.30	38833.86
9	-3228903.22	38831.80
10	-3228900.34	38875.71
11	-3228887.56	38878.21
12	-3228882.19	38955.96
13	-3228901.37	38957.49
14	-3228900.27	38992.73
15	-3228886.64	38999.82
16	-3228863.11	38969.28
17	-3228817.27	38987.38
18	-3228825.93	39012.32
19	-3228771.01	39035.25
20	-3228760.90	39009.63
21	-3228730.93	39021.46
22	-3228738.52	39042.73
23	-3228706.60	39063.95
24	-3228652.71	39085.61
25	-3228631.00	39086.67
26	-3228595.30	39029.83
27	-3228617.05	38905.72
28	-3228655.24	38892.80
29	-3228661.46	38906.17
30	-3228679.23	38897.23
31	-3228673.87	38884.33
32	-3228735.83	38852.79

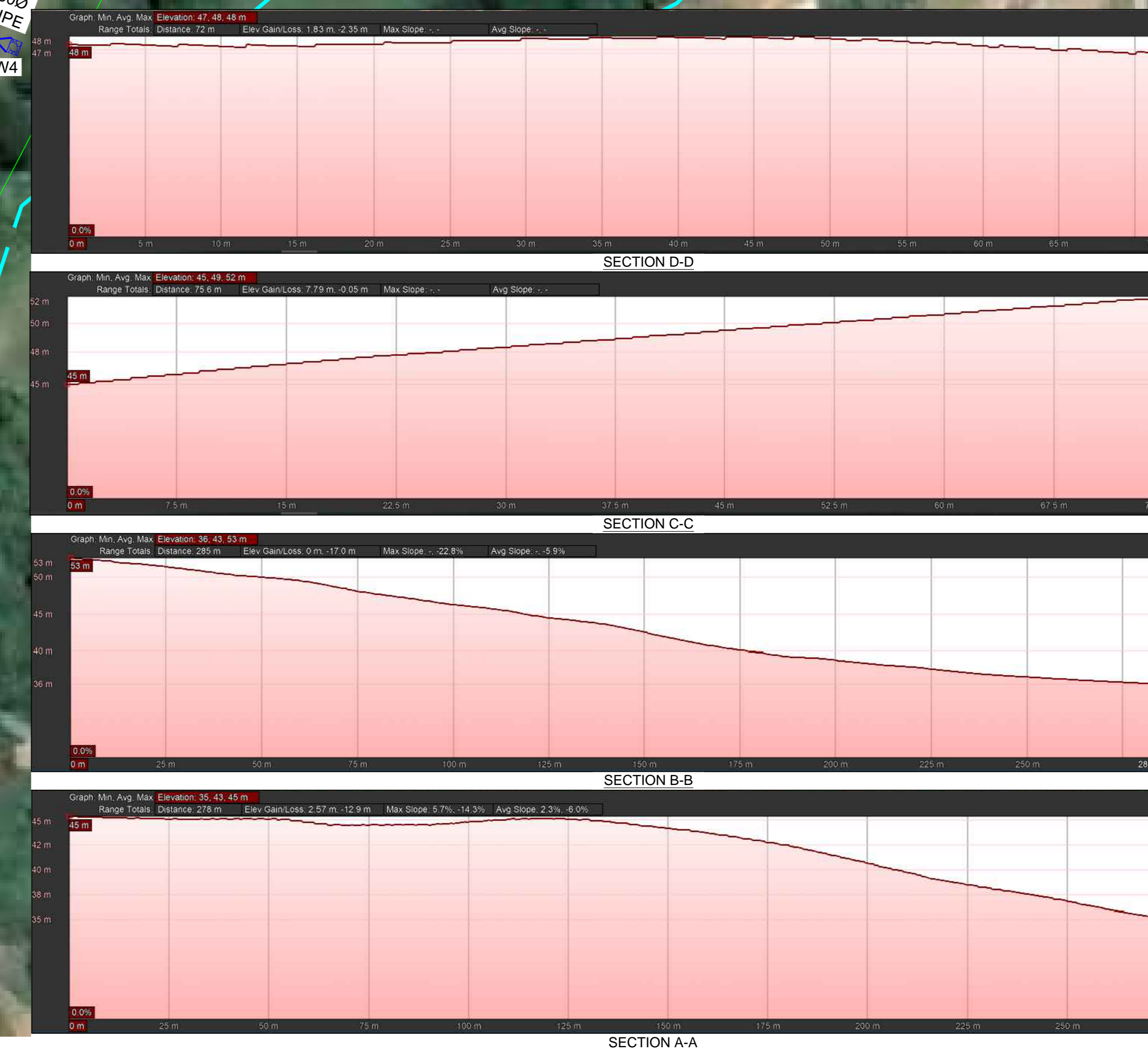
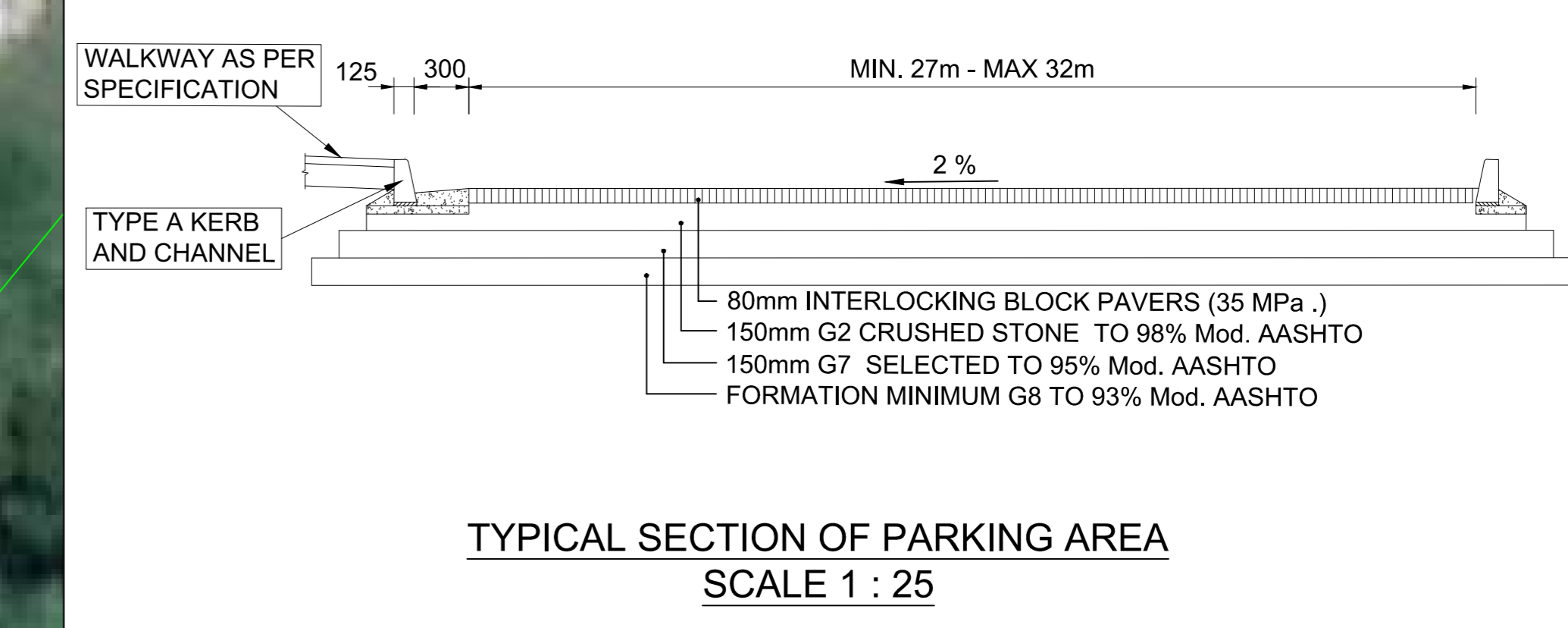
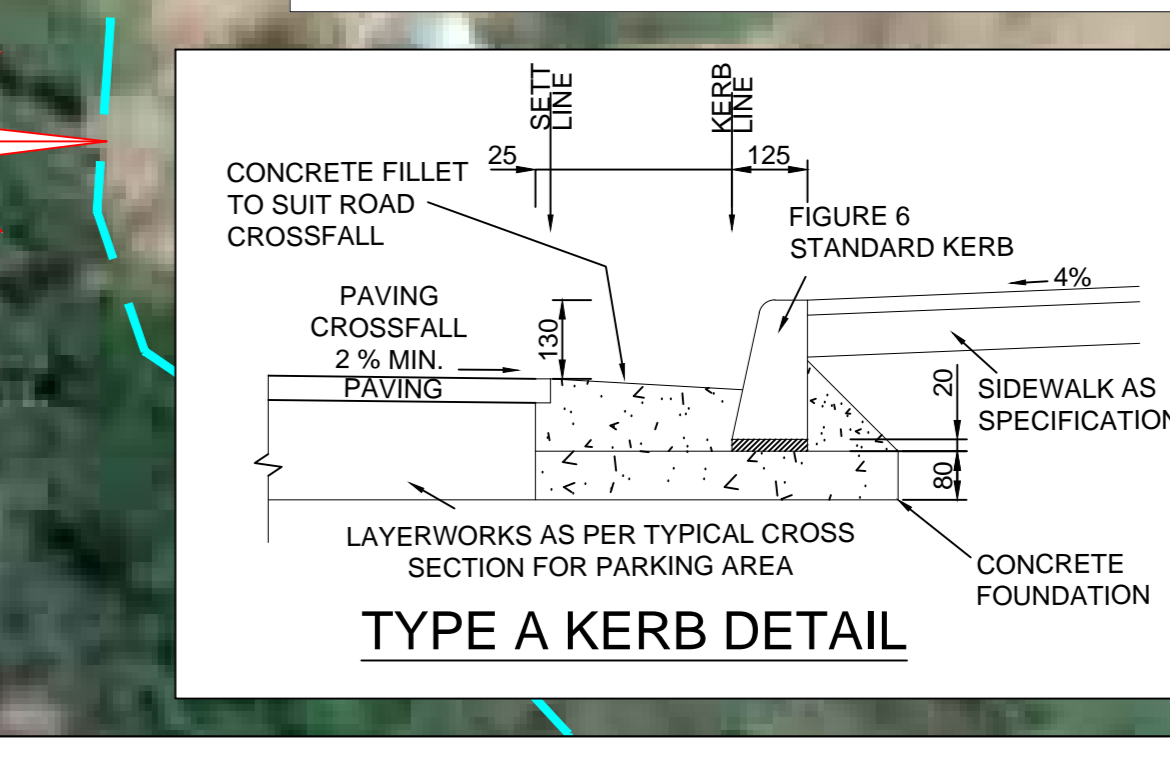
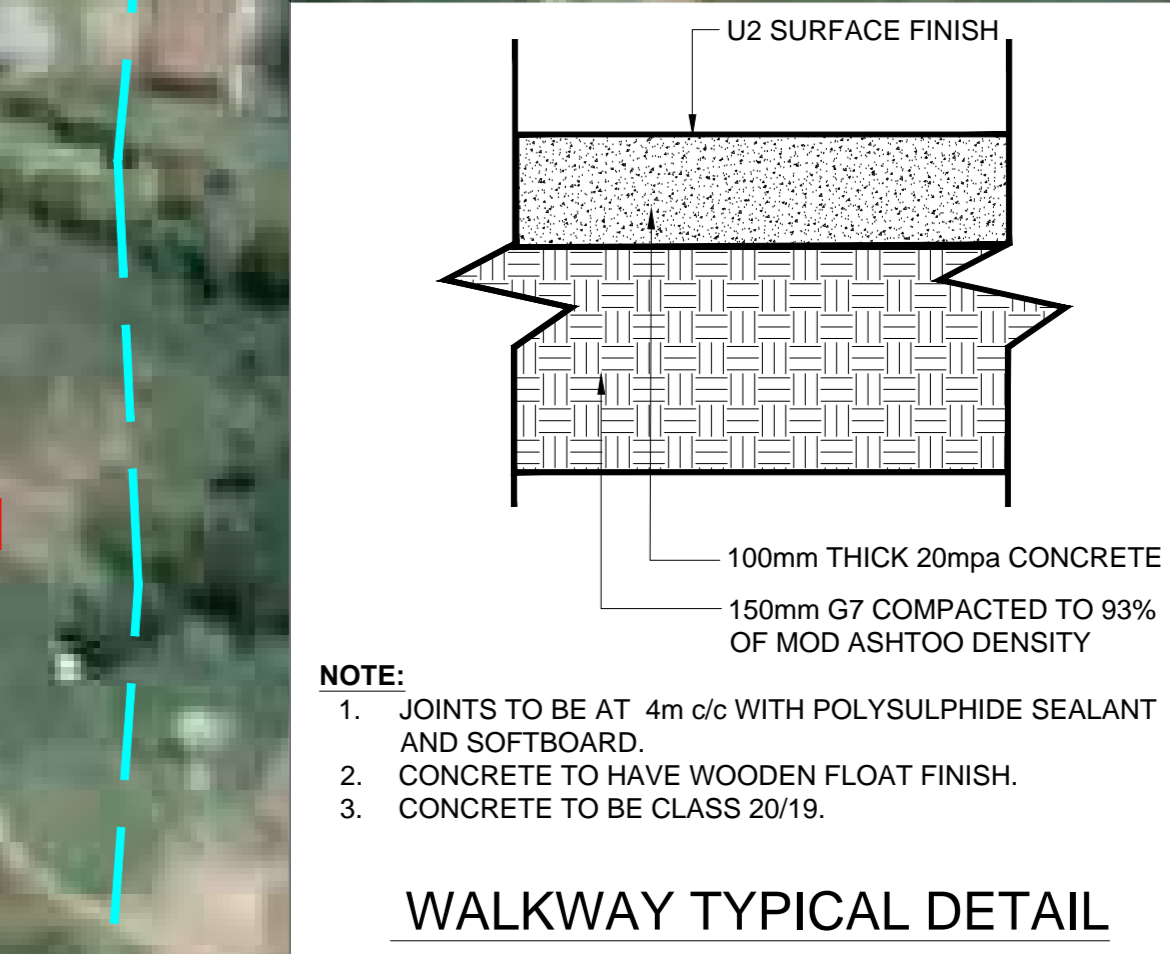
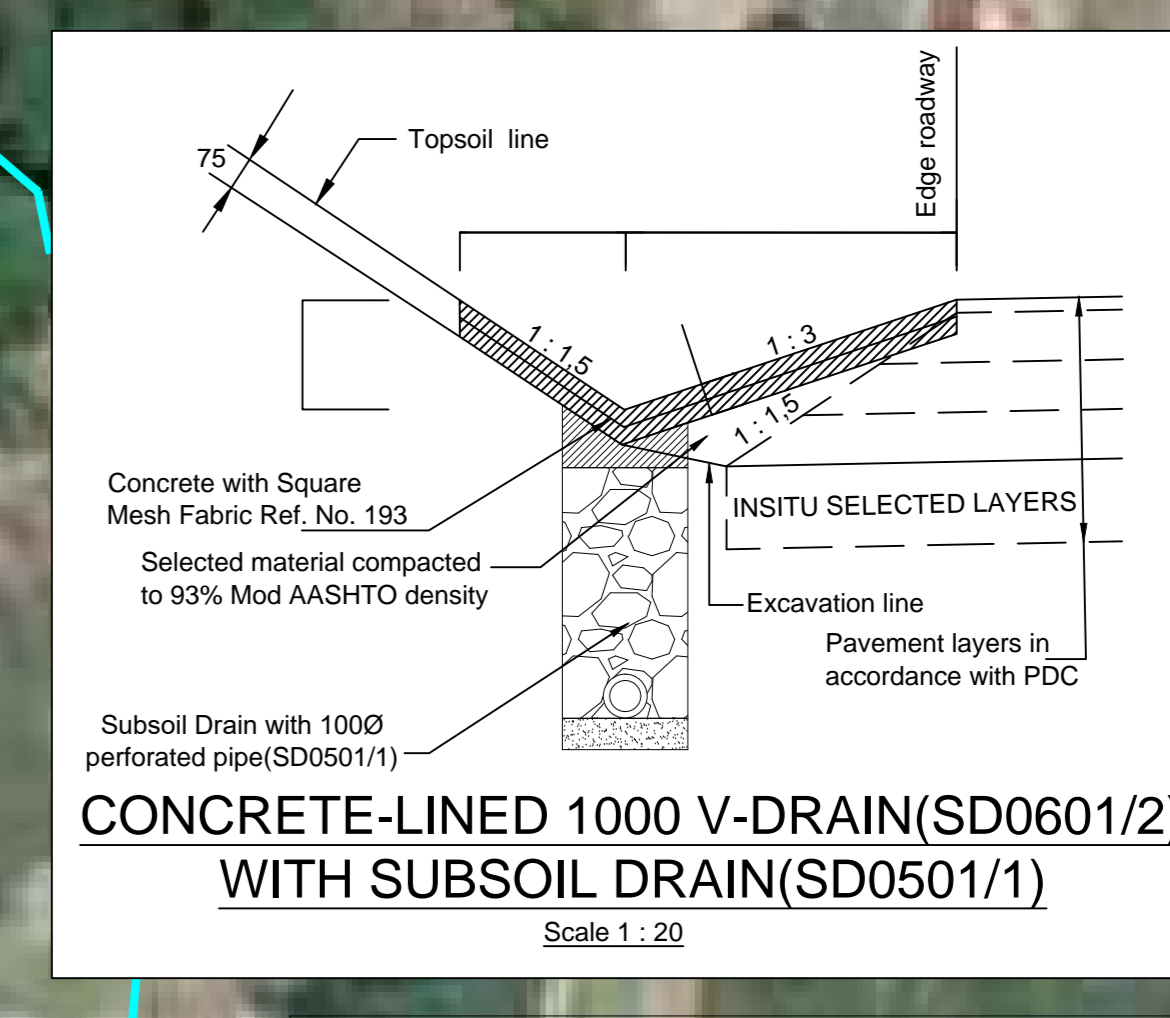
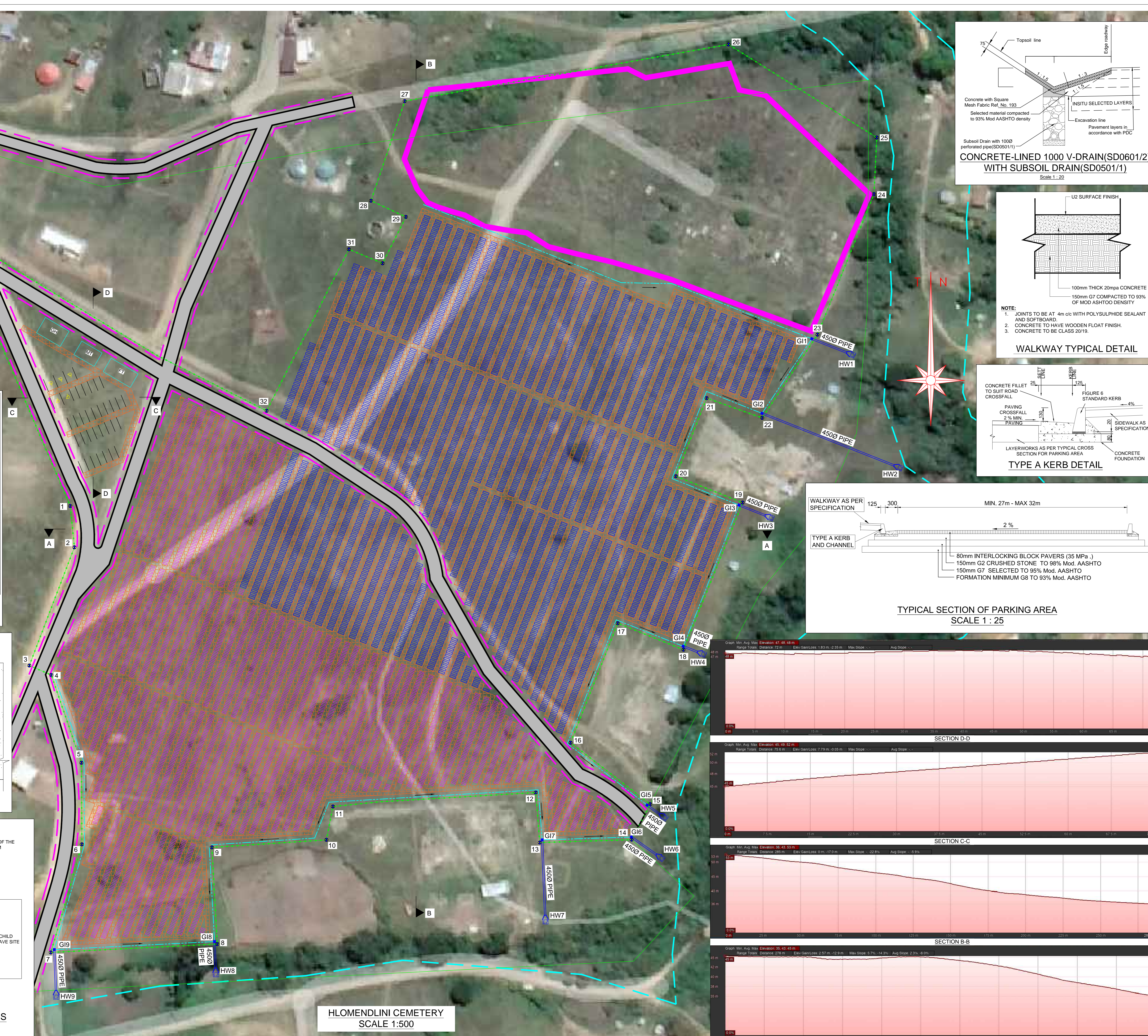
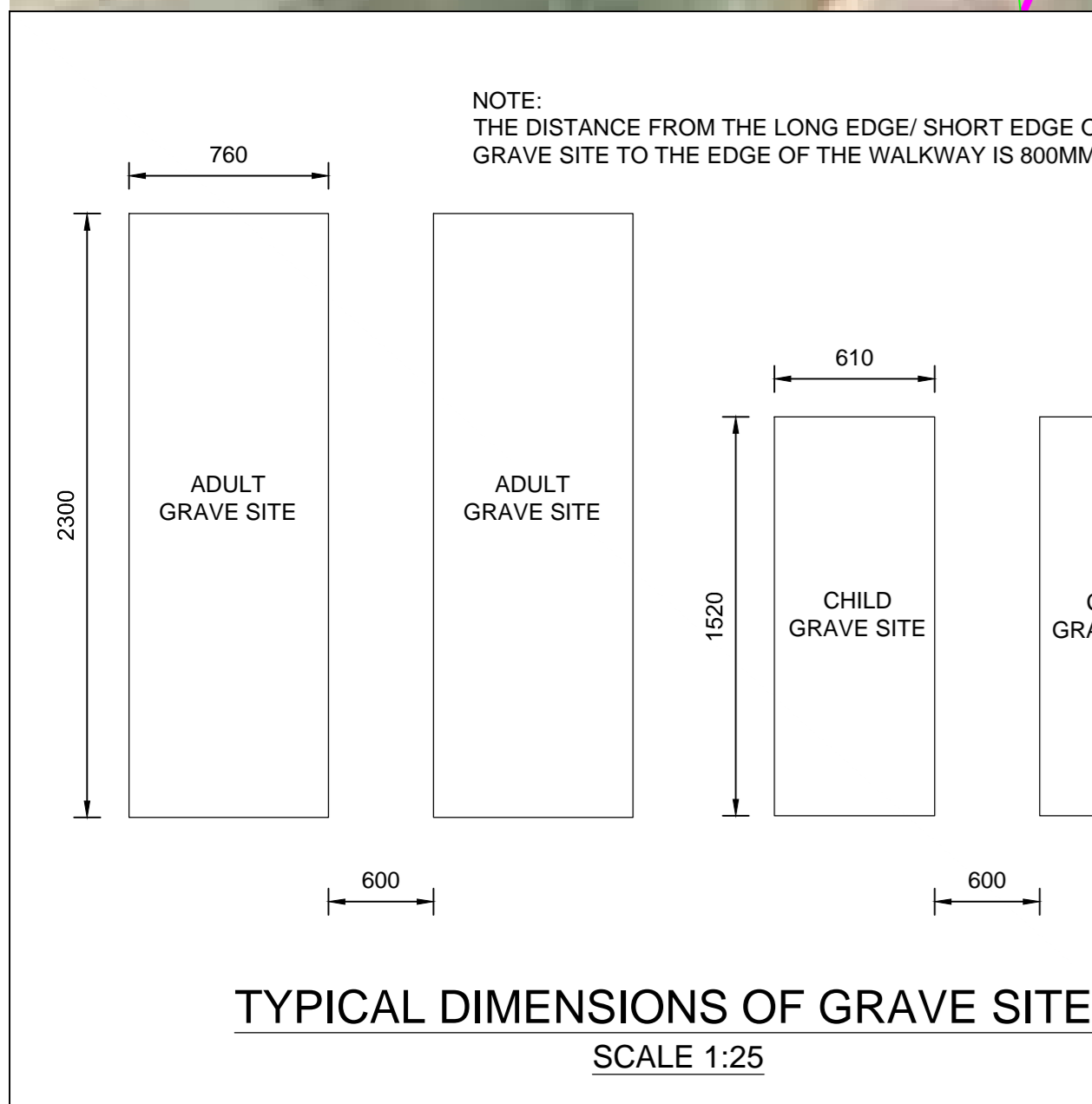
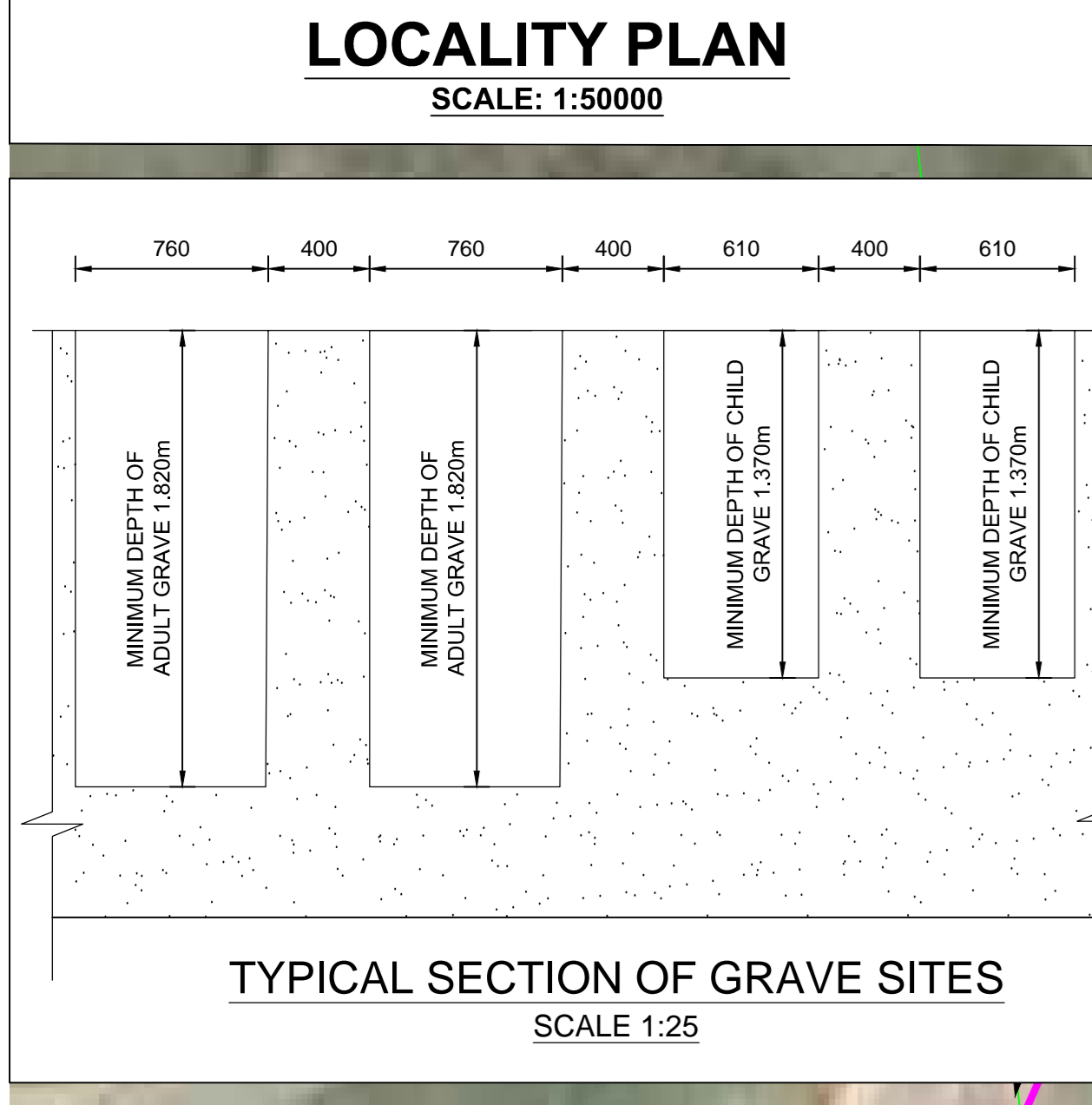
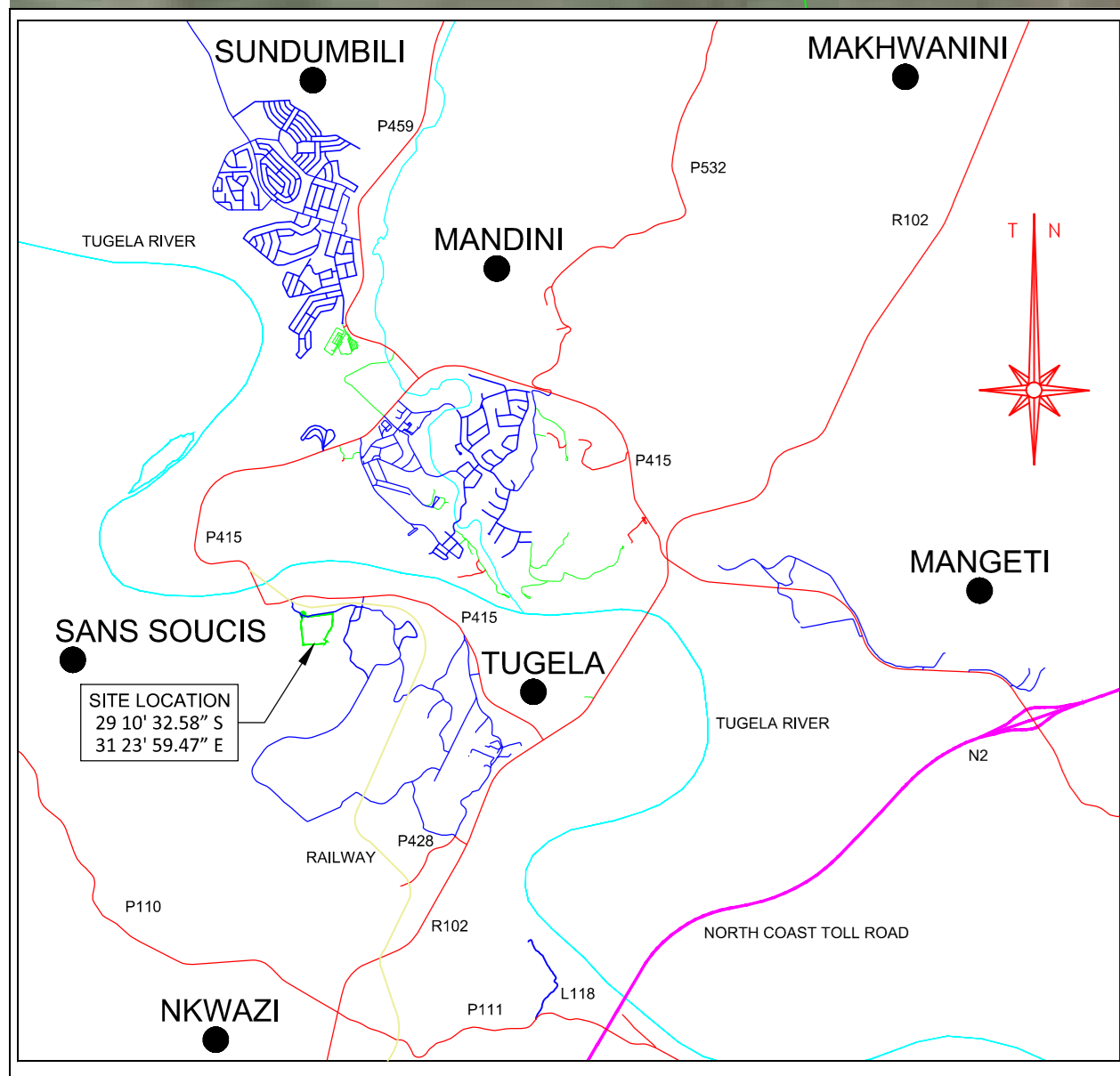

MANDENI MUNICIPALITY

MANDENI MUNICIPALITY

REDUCED PLAN USE SCALE BELOW

0 10 20 30 40 50 60 70
70mm ON ORIGINAL PLAN

NANKHOO
Consulting Engineers
www.nankhoo.co.za

GATEWAY OFFICE PARK, BLOCK 1, CARACLOS, EMLINGA 4001
TEL: (011) 58810
FAX: 08604212
EMAIL: nankhoo@nankhoo.co.za

PLAN DESCRIPTION	DWG. NO.	SHEET NO.
CONTINUED FROM		
CONTINUED ON		

CROSS SECTIONS
TYPICAL CROSS SECTION

SURVEY LAYOUT

LEGEND

- RIVER BUFFER ZONE
- ROAD RESERVE
- PROPOSED CEMETERY SITE
- ADULT GRAVE SITES
- CHILD GRAVE SITES
- AREA OF EXISTING GRAVE SITES
- GH GUARDHOUSE
- MT MALE TOILET
- FT FEMALE TOILET
- WALKWAY
- FENCE
- HEADWALL AND RENO MATTRESS
- GRID INLET
- DIRECTION OF FLOW
- 1.5M V-DRAIN

Revision	Date	Description
1		Acquisitions completed

NOTE: No construction work to commence until land and servitude acquisitions have been completed.

Acquisitions completed

Underground Services Checked

SERVICE	DATE	SIGNATURE
SEWERS		
WATER MAINS		
TELKOM CABLES		
ELECTRIC CABLES		
S.A.R. CABLES		
E.S.C. CABLES		
OIL PIPE LINE		

NOTE: Only underground services affected by new construction work are shown. Care must be taken during excavations for road foundations, trenches etc. to avoid damage to underground services such as sewers, drains, cables, water mains and conduits. Wherever possible these must be located before work proceeds.

Contract No:

Project Title: **MANDENI CEMETERY**

Drawing Title: **HLOMENDLINI CEMETERY**

Scales: AS SHOWN Reference: 100 YR FLOOD RISK-PROPOSED CEMETERY SITE

Designed: A.S Date: 03/06/2022

Checked: P.N Drawn by: S.N

Senior Manager:

Deputy Head:

Head: Engineering

Drawing No: Sheet 01 of 01 Sheets

HLOMENDLINI CEMETERY
SCALE 1:500