



Appendix 1: Title Deeds / SG Diagrams

Deeds Office Property



KLIPGATS PAN, 117, 3 (CAPE TOWN)

GENERAL INFORMATION

Deeds Office CAPE TOWN
 Date Requested 2015/10/23 10:08
 Information Source DEEDS OFFICE
 Reference -



PROPERTY INFORMATION

Property Type FARM
 Farm Name KLIPGATS PAN
 Farm Number 117
 Portion Number 3
 Local Authority PRIESKA DC
 Registration Division PRIESKA RD
 Province NORTHERN CAPE
 Diagram Deed T2467/1945
 Extent 2662.8223H
 Previous Description KLIP PAN A
 LPI Code C06000000000011700003

OWNER INFORMATION

Owner 1 of 2

Person Type PRIVATE PERSON
 Name RUDOLPH GERHARDUS JACOBUS
 ID Number 5112175002086
 Title Deed T18316/2008
 Registration Date 2008/03/11
 Purchase Price (R) 2,390,000
 Purchase Date 2007/12/19
 Share *
 Microfilm Reference 2008 0353 5074
 Multiple Properties NO
 Multiple Owners YES

Owner 2 of 2

Person Type PRIVATE PERSON
 Name RUDOLPH HELENA FRANCINA
 ID Number 5405180058089
 Title Deed T18316/2008
 Registration Date 2008/03/11
 Purchase Price (R) 2,390,000
 Purchase Date 2007/12/19
 Share *
 Microfilm Reference 2008 0353 5074
 Multiple Properties NO
 Multiple Owners YES

ENDORSEMENTS (4)

#	Document	Institution	Amount (R)	Microfilm
1	K14/1971PC	-	UNKNOWN	
2	K7/1970PC	-	UNKNOWN	
3	K862/1977PC	-	UNKNOWN	
4	FARM PR 117/3	-	UNKNOWN	1985 0061 1191

HISTORIC DOCUMENTS (8)

#	Document	Owner	Amount (R)	Microfilm
1	B24330/1999	-	UNKNOWN	2004 1183 2225
2	B18724/2006	-	UNKNOWN	2008 0353 5314
3	T11654/1956	BUYS ERNISTUS JACOBUS	UNKNOWN	1999 0270 0967
4	T34062/1999	BUYS FREDERICK JOHANNES JACOBUS	ESTATE	1999 0376 2146
5	T48408/1999	BUYS PIETER JACOBUS	393,431	2004 1183 2206
6	T99838/2004	VAN WYK BROERS BOERDERY TRUST	825,475	2006 0729 0063
7	T13197/2006	NELSPHOORTJIE BOERDERY PTY LTD	1,065,130	2008 0353 5151
8	T13197/2006	NELSPHOORTJIE BOERDERY C C	1,065,130	2008 0353 5151

DISCLAIMER

This report contains information gathered from our suppliers and we do not make any representations about the accuracy of the data displayed nor do we accept responsibility for inaccurate data. WinDeed will not be liable for any damage caused by reliance on this report. This report is subject to the terms and conditions of the [WinDeed End User Licence Agreement \(EULA\)](#).

D31

H24

UITVOERING - EXECUTION

D16

V9

M4

SYMINGTON & DE KOK
KAAPSTAD
1082
TEL: 913 3137

A. VIR AKTEKANTOOR GEBRUIK / FOR DEEDS OFFICE USE:
(a) Datum van indiening / Date of lodgement:

LODGED
2008-02-25
INGEDIEN

(b)

	Onsersokers / Examiners	Kamers Rooms	Skakeling / Linking	Verwerp / Reject	Passer / Pass
1	I.BRINKHUIS1312F		3 2		
2	L. COETZER 1233				
3					

A. VIR AKTEBESORGER SE GEBRUIK / FOR CONVEYANCER S USE:
Aard van Akte byv.: Transport, Verband, ens.
Nature of Deed e.g.: Transfer, Bond, etc.

T 000018316 / 2008

Verw. No/ Ref. No.:
MAN 1392

Skakeling / linking
3 21

GELYKTYDIGE / SIMULS

Kode Code	Name van Partye / Names of Parties	Firma No. Firm No.	No. in stel/batch	Titelaktes ens. binne Titles etc. within
1	R. nelsoppe	1082	1	T1397/06
2	Rudolph	082	2	
3	Assn	1082	3	
4	10 MAR 2008			
5	CAPE TOWN			
6	IN FOR EXECUTION			
7				
8				
9				
10				
11				

Registrasie versoek deur:
Registration requested by: _____

080004028879

(Kort beskrywing van eiendom (slegs para. 1 in Akte) / (Brief description of property (only para. 1 in Deed)

R117
PACLOK

FEE
R. 650,00

Opgestel deur my

TRANSPORTBESORGER
FOUCHÉ J

000018316 / 2008

TRANSPORTAKTE

HIERBY WORD BEKEND GEMAAK DAT

JANINE FOUCHÉ

Voor my verskyn het, REGISTRATEUR VAN AKTES, te KAAPSTAD, hy die genoemde komparant synde behoorlik daartoe gemagtig deur 'n Volmag aan hom verleen deur

NELSPOORTJIE BOERDERY BK
Nr. 2006/183216/23

Geteken te Prieska op 21 Desember 2007.

DATA / CAPTURE
17 MAR 2008
VAN WYK Z

DATA / VERIFY
19 MAR 2008
LAWRYE

2.

En genoemde Komparant het verklaar dat sy prinsipaal op 19 Desember 2007, waarlik en wettiglik verkoop het by Privaat ooreenkoms, en dat hy, in sy voorgenoemde hoedanigheid hierby sedeer en transporteer aan en ten gunste van

GERHARDUS JACOBUS RUDOLPH
Identiteitsnommer 511217 5002 086
En
HELENA FRANCINA RUDOLPH
Identiteitsnommer 540518 0058 089
Getroud binne gemeenskap van goedere met mekaar

Hul erfgename, eksekuteurs, administrateurs of regverkrygendes, in volkome en vrye eiendom

GEDEELTE 3 (KLIPPAN A) van die Plaas KLIPGATS PAN NR. 117, in die Pixley Ka Seme Distriksmunisipaliteit, Afdeling Prieska, Provinsie Noord-Kaap;

GROOT: 2662,8223 (TWEË DUISEND SES HONDERD TWEË EN SESTIG KOMMA AGT TWEË TWEË DRIË) Hektaar;

AANVANKLIK oorgedra kragtens Verdelingstransportakte Nr. T2467/1945 met Kaart Nr. 4340/1943 wat daarop betrekking het en gehou kragtens Transportakte Nr. T13197/2006.

- A. **ONDERHEWIG** aan die sodanige voorwaardes as waarna verwys word in Transportakte Nr 5135 gedateer 5 Junie 1918.
- B. **KRAGTENS** Notariële Kontrak gedateer 3 Desember 1969 en Notariële Sessie gedateer 29 November 1971 albei geregistreer deur die Registrateur van Mynbriewe te Johannesburg op 10 Maart 1972 onder Prospekterkontrakte Nrs 37 en 38/1972 het die elenaar van die binnegemelde eiendom aan Mercury Mining & Prospecting Company (Proprietary) Limited die reg gegee om op en onder die binnegemelde eiendom vir die "voorboude minerale" te prospekter en te soek; Soos meer ten volle sal blyk uit gesegde Notariële Akte, afskrifte waarvan as volg geliasseer is: Nr 37/1972 by Transportakte Nr T 11654/1956 en Nr 38 by Transportakte Nr T 3303/1965.

- C. **KRAGTENS** Notariële kontrak gedateer 3 Desember 1969 en Notariële Sessie gedateer 29 November 1971 albei geregistreer deur die Registrateur van Mynbriewe te Johannesburg op 10 Maart 1972 onder Prospekteerkontrakte Nrs 41 en 42/1972 het die eienaar van die binnegemelde eiendom aan Mercury Mining & Prospecting Company (Proprietary) Limited die reg gegee om op en onder die binnegemelde eiendom vir edelgesteentes te prospekteer en te soek; Soos meer ten volle sal blyk uit gesegde Notariële Aktes, afskrifte waarvan as volg geliasseer is: Nr 41/1972 by Transportakte Nr T 11654/1956 en Nr 42/1972 by Transportakte Nr T 3033/1965.
- D. **KRAGTENS** Notariële Akte Nr K 61/1975 S is die binnevermelde eiendom onderhewig aan die reg ten gunste vna Elektrisiteitsvoorsieningskommissie om elektrisiteit daarvoor te lei, tesame met bykomende regte, en onderhewig aan voorwaardes, soos vollediger sal blyk uit die gesegde Akte.
- E. **KRAGTENS** Notariële Akte Nr K 184/1983 S gedateer 1 Maart 1983 is die roete waarna verwys word in Notariële Akte Nr K 61/75 nou bepaal; soos meer volledig sal blyk uit gesegde Notariële Akte.
- F. **KRAGTENS** K 778/2002 S gedateer 7 Augustus 2002 is die binnegemelde eiendom onderhewig aan 'n Kraglynserwituut ten gunste van ESKOM met bykomende regte.

4.

WESHALWE die komparant afstand doen van al die regte en titel wat

TRANSPORTGEWER

Voorheen op genoemde eiendom gehad het, en gevolglik ook erken dat dit geheel en al van die besit daarvan onthef en nie meer daartoe geregtig is nie en dat, kragtens hierdie akte, bogenoemde

TRANSPORTNEMERS

Hul erfgename, eksekuteurs, administrateurs of regverkrygendes, tans en voortaan daartoe geregtig is, ooreenkomstig plaaslike gebruik, behoudens die regte van die Staat en ten slotte erken hulle dat die verkoopprijs die bedrag van R2 390 000,00 (TWEË MILJOEN DRIË HONDERD EN NEGENTIG DUISEND RAND) beloop.

TEN BEWYSE WAARVAN ek, genoemde Registrateur, tesame met die Komparant hierdie Akte onderteken en dit met die ampseël bekragtig het.

Onderteken, verly en met die ampseël bekragtig op die kantoor van die Registrateur van Aktes te Kaaptstad op

11 MAR 2008

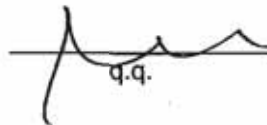
q.q.

In my teenwoordigheid

REGISTRATEUR VAN AKTES



Opgestel deur my,

PROKUREUR
VAN NIEKERK, M

1-3

①

Mede-onderteken deur my

TRANSPORTBESORGER
FOUCHÉ J

VOLMAG OM TRANSPORT TE GEE

Ek, die ondergetekende

BENJAMIN PETRUS FOURIE in my hoedanigheid as lid van
NELSPOORTJIE BOERDERY BK No. 2006/183216/23
behoorlik daartoe gemagtig *Kragtens 'n Resolusie*

C.N.

benoem hiermee

NICOLAAS JOHANNES WEHMEYER en of **MICHÉLE MARAIS** en of **WILLEM JACOBUS SMITH** en of **GREGORY JOHN CLAUGHTON** en of **JACO MINNIE**

JANINE FOUCHÉ

met mag van substitusie om as my ware en wettige Gemagtigde en Agent te verskyn voor die REGISTRATEUR VAN AKTES te Kaapstad, en daar en dan namens my transport uit te maak aan

E.M.

GERHARDUS JACOBUS RUDOLPH
Identiteitsnommer 511217 5002 08 6

en
HELENA FRANCINA RUDOLPH
Identiteitsnommer 540518 0058 08 9

Getroud binne gemeenskap van goedere met mekaar

van die volgende eiendom

GEDEELTE 3 (KLIPPAN A) van die plaas **KLIPGATS PAN Nr. 117**, Pixley Ka Seme Distriksmunisipaliteit, Geleë in die Afdeling van Prieska, Provinsie Noord-Kaap;

GROOT: 2662,8223 (TWEË DUISEND SES HONDERD TWEË EN SESTIG KOMMA AGT TWEË TWEË DRIË) Hektaar

E.M.

GEHOU KRAGTENS Transportakte T13197/2006



GhostConvey 9.7.3.8a

E.M.



wat verkoop is aan die koper/s deur die verkoper/s op 19 Desember 2007, vir die bedrag van R2 390 000,00 (Twee Miljoen Drie Honderd en Negentig Duisend Rand), in volle en vrye eiendom.

Wat behoorlik betaal of verseker is, en in die algemeen, ten einde voorgenoemde doeleindes uit te voer of te laat doen as wat nodig is, net so volmaak en doeltreffend asof ekself teenwoordig was en hierin gehandel het, en hiermee word bekragtig en toegestaan en word belowe en ooreengekom om te bekragtig en toe te staan, alles en wat ook genoemde Prokureur en Agent kragtens hierdie akte wettiglik doen en laat doen.

Geteken te PRIESKA op 21 Desember 2007
in teenwoordigheid van die ondergetekende getuies.

AS GETUIES:

1. 

2. E. mantz



NELSFORTJIE BOERDERY BK

For Information Only



2

**TRANSFER DUTY
VALUE-ADDED TAX**

TD5

**Declaration by transferor and transferee
where a transaction is subject to VAT and
exempt
from Transfer Duty in terms of section 9(15)
of
the Transfer Duty Act.**

Transfer Duty Act, 1949 and Value-
Added Tax Act, 1991

Part 2

Our Reference : 137274

Details of seller(s) or transferor(s)

Full name: NEL SPOORTJIE BOERDERY BK

Identity/Trust/CC/Company Number: 020067183216723

Income tax reference number: 09776779171478P

If you are a VAT Vendor, state your VAT Registration Number: YES 4700219829

If you are not registered for Income Tax, state your annual income from all sources: R 0.00

Marital Status: N/A

Spouse name:

Marital Notes:

Details of purchaser(s) / Transferee(s)

Full name: GERHARDUS JACOBUS RUDOLPH

Identity/Trust/CC/Company Number: 005112175002086

Income tax reference number: 000735702270575

If you are a VAT Vendor, state your VAT Registration Number: YES 4060242783

If you are not registered for Income Tax, state your annual income from all sources: R 0.00

Marital Status: IN COMMUNITY

Spouse name: HELENA FRANCINA RUDOLPH

Marital Notes:

Full name: HELENA FRANCINA RUDOLPH

Identity/Trust/CC/Company Number: 005405180058089

Income tax reference number: 000000000000N/A

If you are a VAT Vendor, state your VAT Registration Number: NO 0000000000

If you are not registered for Income Tax, state your annual income from all sources: R 0.00

Marital Status: IN COMMUNITY

Spouse name: GERHARDUS JACOBUS RUDOLPH

Marital Notes:

Property Details (As per Deeds registry)

Description of Property (as per deeds registry): GEDEELTE 3 (KLIPPAN A) VAN DIE PLAAS KLIP GATSPAN NR 117 PIXLEY KA SEME DISTRIKS MUNISIPALITEIT, GELEE IN DIE AFDELING VAN PRIESKA, PROVINSIE NOORD-KAAP

Nature of property: IMPROVED

If improved indicate: FARM

PRIESKA

NOORD-KAAP

Postal Code: 08940

Details of purchase transaction

Date of transaction: 19 DEC 2007

Bought by: PRIVATE TREATY

Total Consideration: R 239000000

Calculation of VAT payable

VAT Rate	Z E R O			
1. Payment of the VAT is tendered herewith	R			
2. The output tax will be declared in the VAT201 return for the	period	N O		
3. The supply is that of a going concern which qualifies for the zero rate	Y E S			
Name of Conveyancer firm	M & M V A N N I E K E R K I N G			
Conveyancer Reference No	M R 0 0 1 7			
Reference No	4 5 5 8 5 4 / 9	Telephone	0 5 3	3 5 3 1 1 3 1

Declaration by Conveyancer / Attorney

I <u>Fans Jacobs</u> (full name) hereby certify that this is a true copy of the transfer duty receipt / exemption certificate, drawn from the SARS website (e-filing only).	
Signature	Date <u>25 January 2008</u>

For Information Only

AANSOEK OM MAGTIGING VIR REGISTRASIE VAN OORDRAG VAN ONROERENDE EIENDOM
APPLICATION FOR AUTHORISATION FOR REGISTRATION OF TRANSFER OF IMMOVABLE PROPERTY

Magtiging word hiermee aangevra vir registrasie van Oordrag van Onroerende Eiendom.
Authority is hereby requested for registration of transfer of immovable property.

TRANSPORTGEWER: **NELSPOORTJIE BOERDERY BK**
TRANSFEROR: **POSBUS 382, PRIESKA, 8940**

TRANSPORTNEMER: **GERHARDUS JACOBUS RUDOLPH EN HELENA FRANCINA**
TRANSFEE: **RUDOLPH, POSBUS 13602, VORNA VALLEY, 1686**

EIENDOMSBEKRYWING:
PROPERTY DESCRIPTION:

GEDEELTE 3 (KLIPPAN A) VAN DIE PLAAS KLIPGATS PAN NR. 117, PIXLEY KA SEME DISTRIKSMUNISIPALITEIT, AFDELING PRIESKA, PROVINSIE NOORD-KAAP;

GROOT: 2662,8223 (Tweeduisend Seshonderd Twee en Sestig Komma Agt Twee Twee Drie) HEKTAAR

KOOPDATUM/PURCHASE DATE: **19 DESEMBER 2007**

KOOPPRYS/PURCHASE PRICE: **R2 390 000,00**

GEHOU KRAGTENS/HELD BY: **TRANSPORTAKTE NR. T13197/2006**

MUNISIPALITEIT/MUNICIPALITY: **PIXLEY KA SEME**

MAGTIGING VIR REGISTRASIE VAN OORDRAG VAN ONROERENDE EIENDOM
AUTHORITY FOR REGISTRATION OF TRANSFER OF IMMOVABLE PROPERTY

Magtiging word hierby ingevolge Artikel 118(1), (2), (3), van die Wet op Plaaslike Regering: Munisipale Stelsel 2000 verleen vir die registrasie van die oordrag van die eiendom hierin beskryf.
In terms of Section 118(1), (2), (3), of the Local Government Municipal System Act, 2000 authorization is hereby granted for the registration of the transfer of the property s here in described.

Alle bedrae verskuldig ten opsigte van bogemelde eiendom/me vir Munisipale dienste, gelde, opslag op fooie, eiendomsbelasting, ander Munisipale belasting en heffings op dienste gedurende die drie jare wat die datum van hierdie klaringsertifikaat voorafgaan, is ten volle betaal.

All amounts due in connection with the above mentioned property/properties for Municipal services, surcharges on fees, property rates, other Municipal taxes, levies on duties during the three years preceding the date of this clearance certificate, have been fully paid.

Hierdie sertifikaat is geldig tot
This certificate is valid until

120

TESOURIER/TREASURER

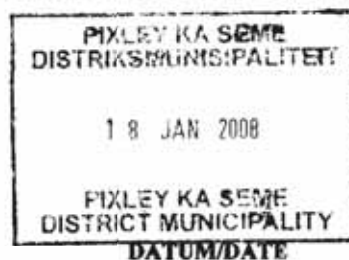



Appendix 2: Expertise of the EAP and Project Team

Nicolene Venter



Name of firm	Zitholele Consulting
Profession	Senior Public Participation Practitioner
Specialisation	Public Participation
No. of years with firm	2 months
Nationality	South African, ID No. 600421 0065 088

Key Experience

Nicolene has over the past 15 years established herself as an experienced and well recognized public participation practitioner, facilitator and strategic reviewer. She has project managed several high profile public participation projects and excels in not only stakeholder engagements but with humility for street level consultation. Nicolene first formed her own consultancy business in 1997 and joined SIVEST in October 2007, and returned to her own consultancy business in October 2011. She lead public participation and stakeholder engagement projects with insightful strategic thinking to ensure the delivery of highly professional and a target orientated public participation process to her clients as the project dictates. She also has sound knowledge of the Equator Principles especially in terms of the Public Participation Process required for projects that are funded internationally. Nicolene's skills base also includes the facilitation of workshops, public and focus group meetings. As the Public Participation Practitioner, her proven leadership skills ensures the managing, development and motivation of the public participation team to achieve project objectives and to maintain high quality standards.

Professional Registrations

Education	International Association for Public Practitioners (IAP2) (Modules 1 and 2)	IAPP	2009
	Diploma in Public Relations	Public Relations Institute of South Africa	1989
	Higher Secretarial Diploma	Pretoria Technikon	1979

Employment Record

2013 - Present	Zitholele Consulting	Public Participation
----------------	----------------------	----------------------

Project Experience

Mining Projects

Proposed AK6 Diamond Mine	Boteti, Botswana
---------------------------	------------------

Drafting of the Community Consultation Plan for inclusion in the Closure Plan for the updated Environmental Management Plan

Power Plants

Zimbabwe Ethenol Plant

Zimbabwe

Consultation process undertaken for the proposed construction of an ethanol plant in Chisumbanje, Middle Sabie, Zimbabwe in terms of the Zimbabwe's Environmental Management Agency (EMA). Not only did consultation take place with Government Officials, but an intensive consultation process has taken place with the local community.

EIA: Hendrina Ash Dam Expansion

Mpumalanga Province, South Africa

Expansion of Eskom's Hendrina Power Station's Ash Dam Facilities at Pullenshope, Mpumalanga Province

EIA: Wind farms and/or Solar Energy Facilities

Northern Cape Province, South Africa

Proposed construction of wind farms and/or solar energy facilities as proposed by Mainstream Renewable Power South Africa, Northern Cape Province.

Basic Environmental Assessment: Grootvlei Power Station

Mpumalanga Province, South Africa

Proposed installation of an additional 500M3 bulk storage fuel tank at Eskom's Grootvlei power Station, Mpumalanga Province

EIA: Solar Energy Facility

Kimberly, South Africa

(Droogfontein, Kimberley; Kaalplats, Loeriesfontein; Paarde Valley, De Aar). The proposed construction of Concentrating Solar Plants (CSP) and Concentrating/Photovoltaic (CPV/PV) Plants as proposed by Mainstream Renewable Power South Africa in the Northern Cape Province.

Linear Infrastructure

EIA: Aggeneis-Oranjemond

Northern Cape Province, South Africa

Proposed construction of a new 400kV Eskom Transmission Power Line between Aggeneys and Oranjemond, and the expansion of the Aggeneis and Oranjemond Transmission Substations, Northern Cape Province

Impact Phase of EIA: Invubu-Theta

KwaZulu Natal, South Africa

Proposed construction of a double circuit 400kV Eskom Transmission Power Line between Richards Bay and Empangeni, KwaZulu-Natal Province

Basic Environmental Assessment: Westrand

Gauteng Province, South Africa

Proposed construction of a 400kV Eskom Transmission Power Line between Eskom's existing Westrand and Hera Substations, Gauteng Province.

EIA: Mookodi Integration Project

North-West Province, South Africa

Proposed improvement of Eskom's electricity supply network around the Vryburg and Stella, and to supply the proposed Kalplats Mine with electricity, North-West Province.

EIA: Transnet Coallink

KwaZulu Natal & Mpumalanga, South Africa

Transnet's coallink upgrade project from Ermelo to Richard's Bay - Class Application for a number of Basic Assessments and Environmental Impact Assessments (5 Applications), Mpumalanga and KwaZulu-Natal Provinces

EIA: Thyspunt Transmission lines Integration Project

Eastern Cape Province, South Africa

Proposed construction of 5 x 400kV Eskom Transmission power lines between Thyspunt (near Oyster Bay) to Port Elizabeth – 180km in length (Eskom's existing Grassridge & Dedisa Transmission Substations), Port Elizabeth, Eastern Cape Province

EIA: Delarey-Kopela-Phahameng

South Africa

Proposed construction of an Eskom Distribution power line from Delareyville past Kopela to Madibogo.

Basic Environmental Assessment: Malelane Substation

Mpumalanga Province, South Africa

Proposed Construction of a New Malelane Substation and the Proposed Construction of a New Komatipoort-Marathon 275kV Eskom Transmission Power Line Turn-In of approximately 1.5km, Malelane, Mpumalanga Province

Other

Miwani Sugar Mill

Kenya

Consultation process undertaken, under the National Environment Management Authority (NEMA) of Kenya, with the assistance of local specialists (Kenya Marine and Fisheries Research Institute) for the proposed construction of a sugar mill in Miwani, Nyanza Province in terms of Kenya's.

EIA: Middelburg Water Treatment Plant

Mpumalanga Province, South Africa

Water reclamation scheme for BHP Billiton Energy Coal South Africa (BECSA) in the Witbank / Middelburg area, Mpumalanga Province

Strategic Management and Review of Stakeholder Engagement Process were also conducted for a number of EIAs / BAs and the completion of Stakeholder Engagement Process between 1997 to September 2007 is available on request

Facilitation responsibility only:

- Environmental Management Plan for Prospecting Right Application Process (Client: Oresund Environmental Solutions): August 2010 and September 2010
- Ariadne-Eros 400kV/132kV Multi-Circuit Transmission Power Line: July 2009 and March 2010 (Client: Acer Africa)
- Middelburg SmancorCR Chemical Plant (Client: Environmental Science Associates) – Public Meeting: October 2007
- Majuba-Venus 765kV Transmission Power Lines (Client: Acer Africa) – Public Meetings: July 2008 and March 2010

Papers, publications and presentations

None

CURRICULUM VITAE – CHRIS VAN ROOYEN

Name of organisation: Chris van Rooyen Consulting
Profession: Ornithological Consultant
Position in Firm: Director/Co-owner
Date of Birth: 30 April 1964
Relevant Experience: 17 years

SPECIALIST FIELD

Ornithological consultant offering specialist advice related to the impact of industrial developments on avifauna, especially in the electricity energy sector.

TERTIARY EDUCATION

1988	B.A. (Law)	Rand Afrikaans University
1991	LLB	Rand Afrikaans University

I work under the supervision of and in association with Albert Froneman (SACNASP Zoological Science Registration number 400177/09) as stipulated by the Natural Scientific Professions Act 27 of 2003.

KEY EXPERIENCE IN ELECTRICITY INDUSTRY

WIND ENERGY SITES

- St Helena Bay, Seeland, Electrawind
- Caledon, Caledon Wind
- Caledon, Langhoogte, SAGIT
- Langebaan, Langfontein, Oelsner Group
- Darling, Kerrifontein Oelsner Group
- Jeffreys Bay, Mainstream
- Ubuntu, Windcurrent
- Bana ba pifhu, Windcurrent
- Coega, Electrawind
- Swellendam, Excelsior, Biotherm
- Vredendal, Inca Energy
- Vredendal, Electrawind
- Morreesburg, Swartberg, Electrawind
- Oyster Bay, Renewable Energies South Africa
- Laingsburg, Spitskopvlakte, Biotherm
- Port Nolloth, Kannikwavlakte, Biotherm
- Vleesbaai, Vleesbaai Independent Power Producer
- Loeriesfontein, Mainstream
- Noupoort, Mainstream
- Indwe, Biotherm
- Pofadder, Mainstream
- Namies, JUWI
- De Aar, Mulilo North
- De Aar, Mulilo South

SOLAR ENERGY SITES:

- Bokpoort, Concentrated Solar Thermal Power (CSP)
- Solar Park, Upington
- Mainstream De Aar PV
- Droogfontein (Kimberley) PV

POWER LINES:

- Chobe 33kV Distribution line
- Athene - Umfolozi 400kV
- Beta-Delphi 400kV
- Cape Strengthening Scheme 765kV
- Flurian-Louis-Trichardt 132kV
- Ghanzi 132kV (Botswana)
- Ikaros 400kV
- Matimba-Witkop 400kV
- Naboomspruit 132kV
- Tabor-Flurian 132kV
- Windhoek - Walvisbaai 220 kV (Namibia)
- Witkop-Overysse 132kV
- Breyten 88kV
- Adis-Phoebus 400kV
- Dhuva-Janus 400kV
- Perseus-Mercury 400kV
- Gravelotte 132kV
- Ikaros 400 kV
- Khanye 132kV (Botswana)
- Moropule – Thamaga 220 kV (Botswana)
- Parys 132kV
- Simplon – Everest 132kV
- Tutuka-Alpha 400kV
- Simplon-Der Brochen 132kV
- Big Tree 132kV
- Mercury-Ferrum-Garona 400kV
- Pebble Rock 132kV
- Reddersburg 132kV
- Thaba Combine 132kV
- Nkomati 132kV
- Louis Trichardt – Musina 132kV
- Endicot 44kV
- Apollo Lepini 400kV
- Tarlton-Spring Farms 132kV
- Kuschke 132kV substation
- Bendstore 66kV Substation and associated lines
- Kuiseb 400kV (Namibia)
- Gyani-Malamulele 132kV
- Watershed 132kV
- Bakone 132kV substation
- Eerstegoud 132kV LILO lines
- Kumba Iron Ore: SWEP - Relocation of Infrastructure
- Kudu Gas Power Station: Associated power lines
- Steenberg Booyse 132kV
- Toulon Pumps 33kV
- Thabatshipi 132kV
- Witkop-Silica 132kV
- Bakubung 132kV
- Nelsriver 132kV
- Rethabiseng 132kV
- Tiilburg 132kV
- and LILO lines
- Stylidrift 132kV
- Taunus – Diepkloof 132kV
- Bighorn NDP 132kV
- Waterkloof 88kV
- Camden – Theta 765kV
- Dhuva – Minerva 400kV Diversion
- Lesedi – Grootpan 132kV
- Waterberg NDP
- Bulgerivier – Dorset 132kV
- Bulgerivier – Toulon 132kV
- Nokeng-Fluorspar 132kV
- Mantsole 132kV
- Tshilamba 132kV
- Thabamooop - Tshebela – Nhlovuko 132kV
- Arthurseat 132kV
- Borutho 132kV MTS
- Grootboom 132kV
- DWAF Steelpoort 132kV
- Chloe – Gilead 66kV
- Pietersburg – Chloe 66kV
- Tshatane – Lesideng 132kV
- Lesego – Jane Furse 132kV
- DWAF 1 – DWAF 2 132kV
- Pitso 132kV Substation
- Lebowa – Dithabaneng – Boynton LILO 132kV

- Zeus-Perseus 765kV
- Matimba B Integration Project
- Caprivi 350kV DC (Namibia)
- Gerus-Mururani Gate 350kV DC (Namibia)
- Mmamabula 220kV (Botswana)
- Steenberg-Der Brochen 132kV
- Venetia-Paradise T 132kV
- Burgersfort 132kV
- Majuba-Umfolozi 765kV
- Delta 765kV Substation
- Braamhoek 22kV
- Steelpoort Merensky 400kV
- Mmamabula Delta 400kV
- Delta Epsilon 765kV
- Gerus-Zambezi 350kV DC Interconnector: Review of proposed avian mitigation measures for the Okavango and Kwando River crossings
- Giyani 22kV Distribution line
- Liqhobong-Kao 132/11kV distribution power line, Lesotho
- 132kV Leslie – Wildebeest distribution line
- A proposed new 50 kV Spoornet feeder line between Sishen and Saldanha
- Cairns 132kv substation extension and associated power lines
- Pimlico 132kv substation extension and associated power lines
- Gyani 22kV
- Matafin 132kV
- Nkomazi_Fig Tree 132kV
- GaKgapane 66kV
- Knobel Gilead 132kV
- Bochum Knobel 132kV
- Madibeng 132kV
- Witbank Railway Line and associated infrastructure
- Spencer NDP phase 2 (5 lines)
- Akanani 132kV
- Hermes-Dominion Reefs 132kV
- Cape Pensinsula Strengthening Project 400kV
- Magalakwena 132kV
- Benfiosa 132kV
- Dithabaneng 132kV
- Taunus Diepkloof 132kV
- Taunus Doornkop 132kV
- Tweedracht 132kV
- Jane Furse 132kV
- Majeje Sub 132kV
- Tabor Louis Trichardt 132kV
- Riversong 88kV
- Mamatsekele 132kV
- Kabokweni 132kV
- MDPP 400kV Botswana
- Marble Hall NDP 132kV
- Bokmakiere 132kV Substation
- Thulamela 132kV
- Marang 132kV
- Thulamela 132kV
- Merensky 132kV
- Amandla – Makometsane - Moutse 132kV
- Lebatlhane 132kV
- Sun City Substation and associated powerlines
- Solar Park 400kV Integration Project
- Mamatsekele 132kV
- KwaMhlanga 132kV
- Malelane – Buffelspruit 132kV
- Gutshwa 132kV
- Taung-Gold 88kV
- Bredasdorp 66kV
- Vaalkop Dam 88kV
- Freedom Park 88kV
- Winterveld 132kV
- Ohrigstad – Phiring – Lemara 132kV
- Blouwater – Uiekraal 66kV
- Houhoek 400kV substation and LILO lines
- Zandfontein – Carmona 88kV
- Bracken – Roscco 88kV
- Victor 132kV
- Gamma – Kappa 765kV
- Kappa – Omega – Aurora 765kV

POWER STATIONS:

- Open Cycle Gas Turbine Plants & The Associated Transmission Lines & Substation At Atlantis, Western Cape
- Kangra Power Station: Siting Report

OTHER PROJECTS:

- Lizard Point Golf Estate
- Lever Creek Estates
- Leloko Lifestyle Estates
- Vaaloewers Residential Development
- Clearwater Estates Grass Owl Impact Study
- Somerset Ext. Grass Owl Study
- Proposed Three Diamonds Trading Mining Project (Portion 9 and 15 of the Farm Blesbokfontein)
- N17 Section: Springs To Leandra –“Borrow Pit 12 And Access Road On (Section 9, 6 And 28 Of The Farm Winterhoek 314 Ir)
- South African Police Services Gauteng Radio Communication System: Portion 136 Of The Farm 528 Jq, Lindley.
- Report for the proposed upgrade and extension of the Zeekoegat Wastewater Treatment Works, Gauteng.
- Bird Impact Assessment for Portion 265 (a portion of Portion 163) of the farm Rietfontein 189-JR, Gauteng.
- Bird Impact Assessment Study for Portions 54 and 55 of the Farm Zwartkop 525 JQ, Gauteng.
- Bird Impact Assessment Study Portions 8 and 36 of the Farm Nootgedacht 534 JQ, Gauteng.
- Shumba’s Rest Bird Impact Assessment Study
- Randfontein Golf Estate Bird Impact Assessment Study
- Zilkaatsnek Wildlife Estate
- Regenstein Communications Tower (Namibia)
- Input into Richards Bay Comparative Risk Assessment Study
- Maquasa West Open Cast Coal Mine
- Glen Erasmia Residential Development, Kempton Park, Gauteng
- Bird Impact Assessment Study, Weltevreden Mine, Mpumalanga
- Bird Impact Assessment Study, Olifantsvlei Cemetery, Johannesburg
- Camden Ash Disposal Facility, Mpumalanga
- Proposed Desalination Project at Mile 6 near Swakopmund, Namibia

CERTIFICATION

I, the undersigned, certify that to the best of my knowledge and belief, these data correctly describe my qualifications and experience.

Date: 17 July 2014



CURRICULUM VITAE

Rebecca Thomas

Name	Rebecca Thomas
Profession	Senior Environmental Consultant
Name of Firm	SiVEST SA (Pty) Ltd
Present Appointment	Senior Environmental Scientist
Years with Firm	3 Years
Date of Birth	21 July 1981
ID No.	8107210457086
Nationality	South African



Education

University of Witwatersrand
Wits Business School

Professional Qualifications

Bachelor of Science (Environmental Science): University of Witwatersrand, 2002
 Postgraduate Diploma in Business Management (PDM): Wits Business School, 2011
 GIBB's Project Leadership Programme, 2010

Previous Employment Record

May 2012 – present	SiVEST SA (Pty) Ltd – Environmental Division : Senior Environmental Scientist
Oct 2009 – Apr 2012	Arcus GIBB (Pty) Ltd – Johannesburg Regional Coordinator and Senior Environmental Scientist. Responsible for leading and providing scientific services for a range of environmental projects including EIAs, environmental planning, environmental feasibility studies, and environmental fatal flaw assessments.
2008 - 2009	Parsons Brinkerhoff Africa (Pty) Ltd Environmental Team Leader Environmental Team Leader responsible for various EIAs for the development of numerous energy related projects within South Africa and Botswana, namely coal-fired power stations and electrical transmission power lines. Tasks included client liaison, financial, programme and staff management and managing and contributing to the drafting of Environmental Impact Reports.
2004 - 2008	Bohlweki Environmental/SSI Engineers and Environmental Consultants Environmental Consultant An environmental consultant active in Environmental Impact Assessments, Environmental Monitoring, Environmental Management Programmes and Environmental Management Systems

Language Proficiency

LANGUAGE	SPEAK	READ	WRITE
English	Fluent	Fluent	Fluent
Afrikaans	Fair	Good	Fair

Key Experience

Rebecca is an Environmental Scientist with 11 years' experience. She specialises in the overall management and compilation of Environmental Impact Assessments (EIAs) and Environmental Management Programmes (EMPs) for large infrastructure projects. Specialising primarily in the energy and public transport sector. She furthermore has been involved in undertaking and managing Public Participation Processes, Consultation, Environmental Scans and Fatal Flaw / Feasibility Studies and independent review of environmental projects. Some of the projects she has worked on recently include EIAs for the REIPPP Wind and Solar Farms and full spectrum advisory services for the Gauteng Rapid Rail Extensions Project, the Polokwane Integrated Rapid Public Transport System and the Moloto Development Corridor. Rebecca also served as one of the advisors in strategic environmental matters for ACSA. She has also completed a Post Graduate Diploma in Business Management (PDM), with the aim of bringing business and project management skills to her projects and division as a whole. From a business administration side, Rebecca is keenly involved in the financial performance, workload and resource planning, quality management and proposal administration for the Johannesburg Environmental Division.

Internationally, Rebecca has work experience in the following countries:

- Botswana
- Tanzania
- Morocco
- Netherlands

Projects Experience

ENVIRONMENTAL MANAGEMENT AND IMPACT ASSESSMENT

Responsible for managing the client and a consulting team to ensure that the EIA process was implemented correctly, on schedule and within budget, the EIA process includes applications, baseline assessments and EIA reports.

- Environmental Advisory Services for the Gauteng Rapid Rail Extensions Feasibility Project, as part of the SMEC Consortium appointed for the Feasibility Study. The project is located across the four local municipalities within the Gauteng Province. Project Leader, SMEC, 2014 - Current
- Environmental Advisory Services for the Moloto Development Corridor (MDC) Project which is located between the City of Tshwane Local municipality in Gauteng Province and Groblersdal, Limpopo Province, traversing Mpumalanga Province. Project Leader, SMEC/VelaVKE, 2012 - 2014
- 3 Year Appointment: Environmental Management Compliance for the Integrated Rapid Public Transport System project for Polokwane Municipality. Project Leader, City of Polokwane, 2013 - Current
- Environmental Screening Studies for the PRASA Rail Upgrade Project – Maintenance Depots and Staging Yards – 21 sites across Gauteng, Western Cape and KwaZulu Natal Provinces. Environmental Project Leader and Reviewer. VelaVKE. February 2012.

CURRICULUM VITAE

Rebecca Thomas

- Environmental advisory services and environmental planning for the ACSA OR Tambo International Airport Midfield Development Project. The project includes review of existing Environmental Authorisations for recommencement of works put on hold, strategic planning for future EIA requirements, including an overall communication strategy to be adopted by ACSA. Senior Environmental Scientist. Airports Company South Africa (ACSA). 2009 – April 2012.
- EIA and EMP for the proposed Thyspunt Transmission Lines Integration Project (TTLIP) for a conventional nuclear power station and associated infrastructure at the Thyspunt site in the Western Cape (Nuclear 1). The project proponent is the Transmission Division of Eskom Holdings SOC Limited. The EIA includes the screening and selection of suitable corridors, as well as a scoping process and detailed Environmental Impact Assessment. The project includes detailed specialist studies, including social, economic, visual and biophysical, EIA process, public consultation and legal. Senior scientist and project leader. Eskom Transmission, 2012 - ongoing.
- EIA and EMP for the proposed 150 MW Renosterberg Wind Energy Company (RWEC) Wind Farm and 75 MW Solar Photovoltaic (PV) Plant, Northern Cape Province. The EIA includes the scoping process and detailed environmental impact assessment. The project includes detailed specialist studies such as social, visual, noise, heritage and biophysical as well as a full public participation process. Senior scientist and project leader. RWEC, 2012 - Current
- EIA and EMP for the proposed Eastside Junction Mixed Use Development near Delmas, Mpumalanga Province. The EIA includes the scoping process and detailed environmental impact assessment. The project includes detailed specialist studies such as social, visual, heritage and biophysical as well as a full public participation process. Senior scientist and project leader. Abland, 2012 – Current
- Environmental Authorisation (EA) Amendment for the proposed Droogfontein 2 and Droogfontein 2 Photovoltaic (PV) Plants near Kimberley, Northern Cape Province. The amendment application included compilation of a motivation for amendment report and public participation as advised by the Department of Environmental Affairs (DEA). Senior scientist and project leader. Mainstream Renewable Power, 2012
- Basic Assessment (BA) processes for the proposed construction of 132 kV power lines required to connect the Droogfontein 2 and Droogfontein 3 PV Plants to the National Electricity Grid. Senior scientist and project leader. Mainstream Renewable Power, 2012
- EA Amendment for the proposed De Aar 2 PV Plants near De Aar, Northern Cape Province. The amendment application included compilation of a motivation for amendment report and public participation as advised by the DEA. Senior scientist and project leader. Mainstream Renewable Power, 2012
- EIA and EMP for the proposed South African Nuclear Energy Corporation (Necsa) Dedicated Isotope Production Reactor (DIPR) at the Pelindaba Site near Hartebeespoort in the North West Province. The EIA includes the scoping process and detailed environmental impact assessment. The project includes detailed specialist studies such as social, visual and air quality as well as a full public participation process. Senior scientist and project leader. Necsa, September 2011 – April 2012.
- Environmental advisory services and permitting process for the Medupi Power Station in Lephalale, Limpopo Province. The project includes extension of borrow pit permits, applications for new borrow pit permits, clarification and justification for the need of waste, water and NEMA permitting requirements, as well as the development of a sustainability strategy for the short, medium and long term construction and operation phases of the power station. Senior scientist and project leader. Eskom Generation, September 2011 – April 2012.

CURRICULUM VITAE

Rebecca Thomas

- EIA for the proposed 25 MW Community Wind Farm in St Helena Bay, Western Cape Province. The EIA includes the scoping process and detailed environmental impact assessment. The project includes detailed specialist studies such as social, visual and biophysical as well as a full public participation process. Senior scientist and project leader. Just Energy, October 2010 – February 2012.
- EIA for the proposed 300 MW Caledon Wind Farm, Western Cape Province. The EIA includes the scoping process and detailed environmental impact assessment. The project includes detailed specialist studies such as social, visual and biophysical as well as a full public participation process. Senior scientist and project leader. Caledon Wind, 2010 - 2012
- Basic Assessment (BA) for the proposed PPC Dwaalboom Boiler Ash Storage Facility. This BA includes the compilation of a Basic Assessment Report and application, public consultation process and environmental management plan for submission to the Department of Environmental Affairs (DEA). Senior scientist and project leader. PPC, 2010.
- Basic Assessment (BA) for the proposed Ekurhuleni Nyoni Regional Park upgrade in Vosloorus, Gauteng Province. This BA includes the compilation of a Basic Assessment Report and application, public consultation process and environmental management plan for submission to the Gauteng Department of Agricultural and Rural Development (G DARD). Senior scientist and project leader. Ekurhuleni Metropolitan Municipality, 2010.
- EIA for the proposed reclamation and treatment of Gaborone (Botswana) wastewater for potable use, this study involved a number of specialist studies and extensive public consultation. Senior scientist. Water Utilities Corporation (WUC), 2010.
- Senior scientist for three EIAs for the Botswana Water Utilities Corporation (WUC). The EIAs are for the upgrading of the Sowa, Jwaneng and Lobatse Water Supply Master Plans. These EIAs are located throughout Botswana and for each includes a detailed scoping and public consultation process, compilation of an environmental management plan and undertaking of identified detailed specialist studies required for the Department of Environmental Affairs decision making, namely visual and heritage studies. Senior scientist. Water Utilities Corporation (WUC), 2010.
- Environmental Screening Study for the proposed co-generation plant to be established at Saldanha Mittal, Western Cape Province. This study included the identification of environmental fatal flaws and licenses required in terms of the proposed project as well as providing a plan indicating how to proceed with the project. Senior scientist and project leader. Exxaro, 2010.
- Environmental Screening Study for the Robertson Community Wind Farm for Just Energy, Western Cape Province. This study included the identification of environmental fatal flaws and licenses required in terms of the proposed project as well as providing a plan indicating how to proceed with the project. Senior scientist and project leader. Just Energy, 2010.
- EIA and EMP for the proposed transmission lines (Bantamsklip – Kappa 765 kV and Bantamsklip – Bacchus, Bacchus - Kappa and Bacchus – Muldersvlei 400 kV) for a conventional nuclear power station and associated infrastructure at the Bantamsklip site in the Western Cape (Nuclear 1). The project proponent is the Transmission Division of Eskom Holdings Limited. The EIA includes the screening and selection of suitable corridors, as well as a scoping process and detailed environmental impact assessment. The project includes detailed specialist studies, including social, economic, visual and biophysical, EIA process, public consultation and legal. Senior scientist and project leader. Eskom Transmission, 2009 ongoing.
- Powerline walkdown assessment and environmental management plan for the Eskom Watershed Mmabatho 132 kV transmission line, North West Province. Senior scientist and project leader. Eskom Distribution, 2010.

CURRICULUM VITAE

Rebecca Thomas

- EIA for the proposed Mulilo Coal Fired Power Station and associated transmission lines near Musina, Limpopo Province. Environmental project co-ordinator. Mulilo Power, 2008 – 2009.
- Environmental Fatal Flaws Analysis for the proposed Sekoko Coal Fired Power Station and associated transmission lines near Lephale, Limpopo Province. Senior scientist. Sekoko Resources, 2009.
- Environmental Fatal Flaws Analysis for the proposed Mulilo Coal Fired Power Station and associated transmission lines near Musina, Limpopo Province. Senior scientist. Mulilo Power, 2009
- EIA for the proposed Mmamantswe Coal Fired Power Station, associated transmission lines and coal mine, Kgatleng District, Botswana. Senior scientist and project leader. Aviva Corporation, 2008 – 2009.
- Environmental Fatal Flaws Analysis for five proposed Investec Wind Farm sites within the Northern Cape Province. Project leader. Investec, 2008.
- EIA for the proposed Upgrade of the Metal Recovery Crushing and Screening Plant at the ArcelorMittal Vanderbijlpark Works, Gauteng Province. Project leader. ArcelorMittal, 2008
- EIA for the proposed extension of the hydra substation and the proposed construction of a new 765 kV transmission power line between the Hydra and Gamma Substations, Northern Cape Province. Environmental scientist. Eskom Transmission, 2007 – 2008.
- EIA for the proposed Mercury – Garona 400 kV transmission power line, traversing the Free State, North West and Northern Cape Province. Environmental scientist. Eskom Transmission, 2007 – 2008.
- EIA for the proposed Atlantis OCGT Power Station and associated 400 kV power lines, Western Cape Province. Environmental scientist. Eskom Transmission, 2007 – 2008.
- Environmental Scoping Study for the proposed 132 kV sub transmission line from Mayfern Traction Substation to Delta Substation in Nelspruit, Mpumalanga Province. Environmental scientist. Eskom Distribution, 2006 – 2007.
- Environmental Scoping Study for the proposed 132 kV sub transmission line between Witkloof Substation and the proposed new Thuli Substation, Carolina, Mpumalanga Province. Environmental scientist. Eskom Distribution, 2006 – 2007.
- Environmental Scoping Study for the proposed 132 kV sub transmission line from Kabokweni Substation to the proposed new Hlau Hlau Substation, Mpumalanga Province. Environmental scientist. Eskom Distribution, 2006 – 2007.
- Environmental Scoping Study for the proposed 132 kV sub transmission line from Kiepersol Substation to Hazyview Traction Substation and upgrading of Kiepersol Substation, Mpumalanga Province. Environmental scientist. Eskom Distribution, 2005 – 2007.
- Environmental Scoping Study for the proposed 132 kV sub transmission lines and proposed new substation to Zandfontein, Mpumalanga Province. Environmental scientist. Eskom Distribution, 2005 – 2006.

STAND ALONE ENVIRONMENTAL MANAGEMENT PLANS / PROGRAMMES

Project management, management of specialist's and compilation of the following projects included:

- Environmental Management Programme and Environmental Control Officer services for the

CURRICULUM VITAE

Rebecca Thomas

Orange Farm Roads Upgrade Project, Gauteng Province. Senior Environmental Scientist and ECO. 2012

- Environmental Control Officer services for the Driezek Housing Upgrade Project, Gauteng Province. ECO. 2011
- Environmental Management Plan for the Morupule B - Phokoje 400 kV Transmission line, Botswana. Project leader. Botswana Power Corporation (BPC), 2008
- Environmental Management Plan for the proposed Phase 1 and 2 developments of the Gardner Ross Golf and Country Estate project, integrating the current Environmental Management Plan in place for phase 1. Environmental Scientist. Gardener Ross, 2005 - 2006

AIR QUALITY IMPACT ASSESSMENT

Involved with the Air Quality Impact Assessments and Dispersion Modelling for the following projects:

- Air Quality Impact Assessment for the proposed Zimplats Smelter expansion, Harare, Zimbabwe. Air quality specialist. Zimplats, 2007
- Air Quality Impact Assessment for the proposed Majuba Combined Cycle Gas Turbine (CCGT) Power Station, Mpumalanga Province. Air quality specialist. Eskom Generation, 2007

SPECIALIST STUDIES

Various specialist study projects, responsible for the project management and day-to-day co-ordination of the following projects, to ensure timeous collection of information and submission of required deliverables:

- Independent Review of the Burnstone Gold Mine Environmental Impact Assessment and Environmental Management Plans, in accordance with the Equator Principles, Mpumalanga Province. Project leader. Snowden, 2008
- Visual Impact Assessment Report for Robinson Deep Landfill, Gauteng Province. Environmental scientist. Pikitup, 2006
- Identification and Compilation of Transwerk Germiston Environmental Aspects and Impacts Register, Germiston, Gauteng Province. Environmental scientist. Transwerk, 2006
- Compilation of CTMM Noise Zoning Report for Regions 1 – 8, Gauteng Province. Environmental scientist. CTMM, 2005
- Water License Applications for New Mining Operations at the Holcim South Africa Dudfield Plant, North West Province. Environmental scientist. Holcim, 2005 – 2006
- Exemption Application and Public Participation Process for the Vaal VRESAP 88 kV Distribution line and new VRESAP Substation. Environmental scientist and project leader, 2006

PUBLIC PARTICIPATION PROCESS

Responsible for the co-ordination of the Public Participation Process, involving the compilation of Public Participation documentation, arranging and co-ordinating public meetings, management of Interested and Affected Party (I&AP) database's and day-to-day solicitation of comments and responses to and from I&APs. Projects included:

CURRICULUM VITAE

Rebecca Thomas

- Public Consultation Process for the Development of the Mbombela Precinct Plans for the Mbombela Local Municipality. Public Consultation Practitioner, 2011.
- SANParks National Database for the Environmental Management Plans for selective National Parks. Public participation consultant. SANParks, 2004

INTERNATIONAL EXPERIENCE

Internationally has provided consulting services on the following projects:

- Environmental Management Plan for the Boteti Diamond Mine in Karowe, Botswana, Project Leader, 2012
- Various energy related projects, Gaborone, Botswana. Environmental Consultant, 2008 – 2011
- Environmental Inception Report for Dar-es-Salaam International Airport (DIA) and the Tanzanian Airport Authority (TAA). Identification of Environmental Impacts, Gap Analysis of existing infrastructure in Dar-es-Salaam and future requirements of the city, inclusive of water and sewage management facilities. Environmental consultant. TAA, 2007
- GIS Mapping and Conservation Management for a Private Game Reserve near Rabat, Morocco. Looking at wildlife management, rehabilitation and renovation of the property as well as game management. Environmental consultant. Confidential, 2007
- Presentation on South African Public-Private Partnership and Environmental Impact Assessment at the Partners for Roads International Conference on Roads and Regional Development, Prague, Czech Republic, 2007
- Three months knowledge exchange and working experience with Bohlweki Environmental Association Company, DHV, in the Netherlands from September 2007 to December 2007

CURRICULUM VITAE

Shaun Taylor

Name Shaun Taylor

Profession Environmental Scientist

Name of Firm SiVEST SA (Pty) Ltd

Present Appointment Environmental Scientist:
Environmental Division

Date of Birth 02 February 1984

ID Number 8402025020082

Nationality South African



Education

MSc – Aquatic Health
 BSc (Hons) – Geography & Environmental Studies
 BA – Geography and Environmental Science

Professional Qualifications

- MSc – Aquatic Health, Johannesburg University
Research Project: The physico-chemical and biological characteristics of selected seasonal pans in the Kruger National Park, South Africa
- BSc (Hons) – Geography & Environmental Studies, Witwatersrand University (First class)
Research Project: Sitatunga Habitat Suitability in the Okavango Delta, Botswana
- BA – Geography & Environmental Science, Monash University South Africa (Distinction)
- Certification in Wetland Delineation and Rehabilitation Training Course from the School of Continuing Education, University of Pretoria

Language Proficiency

LANGUAGE	SPEAK	READ	WRITE
English	Excellent	Excellent	Excellent
Afrikaans	Fair	Fair	Fair

Employment Record

Oct 2010 – Present (Full-time) SiVEST SA (Pty) Ltd Environmental Division – Environmental Scientist

Oct 2009 – Mar 2010 (Part-time) Envirokey cc – Junior Environmental Consultant and GIS support

Aug 2007 – Sep 2009 (Part-time) Holgate, Meyer and Associates Environmental Management Services – Junior Environmental Consultant

Key Experience

Shaun joined SiVEST in October 2010 and is based in the Johannesburg office in the capacity of an Environmental Scientist.

Shaun has a passion for working in the environmental and water (wetlands) field. From an environmental management perspective, Shaun has completed a number of environmental impact assessments, basic assessments, strategic environmental assessments, environmental management plans/programmes, exemption applications, amendment applications and conducted environmental auditing. Within the water field, Shaun has undertaken water use licensing (WUL) and WUL compliance monitoring for various developments. In terms of specialist work, Shaun has completed numerous wetland and riparian assessments for renewable energy projects, linear projects as well as site specific projects. Shaun has also undertaken several wetland rehabilitation plans for developments.

Through his time at SiVEST, Shaun has acquired the following skills:

- Excellent computer skills (Word, excel, powerpoint etc.);
- Excellent proposal and report writing skills;
- Environmental Impact Assessments;
- Environmental Management Plans/Programmes;
- Environmental Compliance and Auditing;
- Environmental Amendment and Exemption Applications;
- Wetland and riparian assessment techniques (including functional assessments);
- Wetland Rehabilitation Plans;
- Water Use License Applications.

Projects Experience

Shaun is responsible for the following activities: conducting EIA, BA and WULA processes, undertaking amendment and exemption applications, general project management, report writing, proposal writing, invoicing, conducting specialist riparian/wetland delineation and functional assessments, environmental and water related compliance monitoring and auditing. Current and completed projects / activities are outlined in detail below.

STRATEGIC ENVIRONMENTAL ASSESSMENTS

- Molemole Local Municipality Strategic Environmental Assessment, Limpopo Province (2014/2015);
- Blouberg Local Municipality Strategic Environmental Assessment, Limpopo Province (2015/2016).

ENVIRONMENTAL IMPACT ASSESSMENTS

- Mookodi Integration Project Environmental Impact Assessment (2011/2012);
- Noupoot Wind Farm, Northern Cape Province (2011/2012);
- Loeriesfontein Wind Farm and PV Plant, Northern Cape Province (2011/2012);
- Renosterberg Wind Farm and PV Plant near De Aar, Northern Cape Province (2012).

BASIC ASSESSMENTS

- Proposed Installation of a 500m³ Bulk Storage Fuel Oil Tank at Grootvlei Power Station, Mpumalanga Province (2011/2012);
- Proposed development of a 19MW Photovoltaic Solar Power Plant near Kimberley, Northern Cape Province (2012);

CURRICULUM VITAE

Shaun Taylor

- Proposed development of a 19MW Photovoltaic Solar Power Plant near Danielskuil, Northern Cape Province (2012);
- Frankfort Strengthening Project: 88kV Power Line from Heilbron (via Frankfort) to Villiers, Free State Province (2013);
- Wilger 132kV Overhead Distribution Power Line, Northern Cape Province (2013/2014);
- Limestone 1 – 132kV Overhead Distribution Power Line, Northern Cape Province (2013/2014);
- Limestone 2 – 132kV Overhead Distribution Power Line, Northern Cape Province (2013/2014);
- Proposed Tweespruit to Welroux Power Line and Substations, Free State Province (2014/2015);
- Sir Lowry's Pass River Flood Alleviation Project, Western Cape Province (2014/2015);
- Loeriesfontein 70MW Photovoltaic and 132kV Power Line, Northern Cape Province (2015/2016).

ENVIRONMENTAL MANAGEMENT PLANS / PROGRAMMES

- Eskom Thyspunt Nuclear Integration Project Environmental Management Plan – Transmission Infrastructure (2011);
- Eskom Thyspunt Nuclear Integration Project Environmental Management Plan – Substations (2011);
- Mookodi Integration Project Environmental Management Plan – Transmission Infrastructure and Substations (2011/12);
- Noupoot Wind Farm Environmental Management Programme (2012);
- Environmental Management Programme for a 500m³ Bulk Storage Fuel Oil Tank at Grootvlei Power Station (2012);
- Environmental Management Programme for a 19MW Photovoltaic Solar Power Plant near Kimberley, Northern Cape Province (2012);
- Environmental Management Programme for a 19MW Photovoltaic Solar Power Plant near Danielskuil, Northern Cape Province (2012);
- Karowe Diamond Mine Environmental Management Plan Review and Update, Boteti District, Botswana (2012);
- Environmental Management Programme for the Frankfort Strengthening Project: 88kV power line from Heilbron (via Frankfort) to Villiers, Free State Province (2013);
- Environmental Management Programme for the Wilger Photovoltaic 132kV Overhead Distribution Power Line, Northern Cape Province (2013);
- Environmental Management Programme for the Limestone 1 Photovoltaic – 132kV Overhead Distribution Power Line, Northern Cape Province (2013);
- Environmental Management Programme for the Limestone 2 Concentrated Solar Power – 132kV Overhead Distribution Power Line, Northern Cape Province (2013);
- Final Environmental Management Programme for the Khobab 140MW Wind Farm, Northern Cape Province (2014);
- Final Environmental Management Programme for the Loeriesfontein 140MW Wind Farm, Northern Cape Province (2014);
- Final Environmental Management Programme for the Noupoot 80MW Wind Farm, Northern Cape Province (2014);
- Environmental Management Programme for the Tweespruit to Welroux 132kV Power Line and Substations, Free State Province (2014/2015);
- Environmental Management Programme for the Loeriesfontein 70MW Photovoltaic and 132kV Power Line, Northern Cape Province (2015/2016).

AMENDMENT APPLICATIONS

- Loeriesfontein 140MW Wind Farm, Northern Cape Province: Substantive and Minor Amendments (2013/2014);
- Khobab 140MW Wind Farm, Northern Cape Province: Substantive and Minor Amendments (2013/2014);

CURRICULUM VITAE

Shaun Taylor

- Loeriesfontein 50MW Wind Farm, Northern Cape Province: Environmental Authorisation Minor Amendments (2013/2014);
- Loeriesfontein 100MW Solar Photovoltaic Plant, Northern Cape Province: Environmental Authorisation Minor Amendments (2013/2014);
- Noupoot 188MW Wind Farm, Northern Cape Province: Environmental Authorisation Minor Amendments (2013/2014);
- Loeriesfontein 132kV Power Line, Northern Cape Province: Environmental Authorisation Minor Amendment (2015).

ENVIRONMENTAL CONSTRAINTS\FATAL FLAWS

- Social Housing Projects in Sasolburg and Secunda Final Environmental Constraints Analysis Report (2011);
- Establishment of Wind Farms in Northern and Eastern Cape Provinces Environmental Constraints Analysis Report (2011).

ENVIRONMENTAL AND WATER USE LICENSE COMPLIANCE AUDITING

- Environmental Compliance Auditing for the Nigel Substation to Jameson Park (Inland Terminal 2) 88kV power lines – Construction Phase (2011);
- Water Use License Compliance Auditing for Grootvlei Power Station, Mpumalanga Province, South Africa (2012);
- Environmental Compliance Auditing for the Meadow Feeds Standerton Broiler Feed Mill, Mpumalanga Province (2012/2013);
- Kusile Power Station Armcors Water Use License Compliance Audit, Mpumalanga Province (2014 & 2015);
- Kusile Power Station Ash Dump Water Use License Compliance Audit, Mpumalanga Province (2014 & 2015);
- Kusile Power Station Pollution Dams Water Use License Compliance Audit, Mpumalanga Province (2014 & 2015);
- Kusile Power Station Stream Diversion and Water Pipeline Crossings Water Use License Compliance Audit, Mpumalanga Province (2014 & 2015);
- Kusile Power Station Geotechnical Water Use License Compliance Audit, Mpumalanga Province (2015);
- Ga-rankuwa 11kV Underground Power Cable Water Use License Compliance Audit, Gauteng Province (2015/2016);
- Transnet Rail Water Use License Compliance Audit, Northern Cape Province (2014, 2015 & 2016).

WATER USE LICENSES

- Integrated Water Use License Application for the Construction of a CSP and CPV/ PV Plant in De Aar, Northern Cape Province of South Africa (2010);
- Water Use License for Ga-rankuwa Substation, Gauteng Province (2013);
- Water Use License for Klevebank to Dalkieth 88kV Power Line, Gauteng Province (2013);
- Water Use License Application for the Frankfort Strengthening Project: 88kV Power Line from Heilbron (via Frankfort) to Villiers, Free State Province (2014/2015);
- Water Use Licensing for the Integrated Polokwane Rapid Public Transport Network, Limpopo Province (2014/2015);
- Water Use License for the Rooipunt Concentrated Solar Power Project, Northern Cape Province (2015);
- Water Use License for the Katulo Tsatsi Solar Park, Northern Cape Province (2015);
- Water Use License for the Limestone Concentrated Solar Power Project, Northern Cape Province (2015);

- Water Use License for the Wilger Photovoltaic Project, Northern Cape Province (2015);
- Water Use License for the Hertzogville Solar Park, Free-State Province (2015);
- Water Use License for the Dwarsrug Wind Farm, Northern Cape Province (2015);
- Water Use License for the Loeriesfontein 70MW Photovoltaic and 132kV Power Line Project, Northern Cape Province (2015).

WETLAND AND RIPARIAN DELINEATION AND FUNCTIONAL ASSESSMENTS

- Construction of a Wind Farm in Noupoot, Northern Cape Province, South Africa: Surface Water Report – Scoping Phase Assessment (2010);
- Construction of a Wind Farm in Prieska, Northern Cape Province, South Africa: Surface Water Report – Scoping Phase Assessment (2010);
- Construction of a Wind Farm in Loeriesfontein, Northern Cape Province, South Africa: Surface Water Report – Scoping Phase Assessment (2010);
- Construction of a 132KV Distribution Line from the Kudu Substation to Dorstfontein Substation in Mpumalanga Province: Surface Water Impact Assessment (2010);
- EIA for the Thyspunt Transmission Lines Integration Project: Surface Water Impact Assessment Report – EIA – Northern Corridor: Eastern Cape Province (2011);
- EIA for the Thyspunt Transmission Lines Integration Project: Surface Water Impact Assessment Report – EIA – Southern Corridor: Eastern Cape Province (2011);
- Construction of a CSP and a CPV/ PV Plant in De Aar, Northern Cape Province, South Africa – Surface Water Assessment – Scoping Phase Assessment (2011);
- Environmental Management Framework for the Mogale City Local Municipality Surface Water Report – Desired State Report: Gauteng Province (2011);
- Proposed Township Development on the Remainder of Portion 27 of the Farm Middelburg and Townsland 287 JS, Mpumalanga Province: Surface Water Assessment (2011);
- Construction of a CSP and a CPV/ PV Plant in De Aar, Northern Cape Province, South Africa: Surface Water Impact Assessment (2011);
- Construction of a CSP and a CPV/ PV Plant in Kimberley, Northern Cape Province, South Africa: Surface Water Impact Assessment (2011);
- Proposed Mixed Use Industrial Township Development in the Daspoort Area of Tshwane, Gauteng Province, South Africa: Surface Water Impact Assessment (2011);
- Westrand Strengthening Project from Westgate Substation to Hera Substation and Westgate Substation Extension, Gauteng Province, South Africa (2011);
- Mookodi Integration Project 2 Basic Assessment Surface Water Impact Assessment, North West Province, South Africa (2012);
- Wetland Site Investigation Report for Arundo Estate in the Midrand Area, Gauteng Province, South Africa (2011);
- Construction of a Gabion Structure at Waterval Substation in the Midrand Area, Gauteng Province, South Africa: Surface Water Impact Assessment (2011);
- Proposed Construction of a Single 400kV Power Line from Borutho to Nzhlele, North West Province, South Africa: Scoping and Impact Surface Water Assessment (2011/2012);
- Proposed Construction of an 88kV Power Line at Palmridge in the Ekurhuleni Metropolitan Municipality, Gauteng Province, South Africa: Surface Water Impact Assessment (2011);
- Proposed Construction of a 19MW Photovoltaic Solar Power Plant near Danielskuil, Northern Cape Province, South Africa: Surface Water Impact Assessment (2012);
- Proposed Rebuilding of a 88kV Power Line from Henneman Substation to Serfontein Substation near Kroonstad, Free State Province, South Africa: Surface Water Impact and Eco-Services Functional Assessment (2012);
- Proposed Deconstruction and Construction of an 11kV Power Line near Delmas, Mpumalanga Province, South Africa: Wetland Delineation, Impact, Functional Assessment and Rehabilitation Plan (2012);
- Proposed Construction of a Solar Photovoltaic Power Plant near De Aar, Northern Cape Province, South Africa: Surface Water Scoping Assessment (2012);

-
- Proposed Construction of a Wind Farm near De Aar, Northern Cape Province: Surface Water Scoping Assessment (2012);
 - Proposed Construction of a Low Cost Housing Development in the Soutpan area of Tshwane, Gauteng Province, South Africa: Wetland Assessment (2012);
 - Proposed Construction of a 132kV Power Line near Kimberley, Northern Cape Province: Surface Water Assessment (2012);
 - Proposed Extension of Delmas Substation and Associated Power Lines, Mpumalanga Province, South Africa: Wetland Delineation, Impact, Functional Assessment and Rehabilitation Plan (2012);
 - Proposed Construction of a Substation in the Midrand area of Gauteng Province: Wetland Delineation and Impact Assessment (2012);
 - Construction of an 88kV Power Line at Lochvaal Kudu in the Emfuleni Municipality, Gauteng Province: Surface Water Impact Assessment and Rehabilitation Plan (2012);
 - Proposed construction of an 88kV Power Line from Klevebank Substation to Dalkeith Substation, Gauteng Province: Wetland and Riparian Delineation, Impact, Functional Assessment and Rehabilitation Plan (2012/2013);
 - Proposed Construction of an 88kV Power Line from Heilbron Substation to Villiers Substation, Free State Province: Surface Water Impact Assessment (2013);
 - Proposed Construction of a 132kV Power Line, Substation and the Extension of Homestead Substation Associated with the 75MW Concentrating Photovoltaic (CPV) / Photovoltaic (PV) Plant (PV 3) on the Farm Droogfontein in Kimberley, Northern Cape Province: Surface Water Assessment (2013);
 - Moddershaft Underground to Overhead Cable Replacement of an 11kV Power Line from Moddershaft Substation to a Minisub near Anzac, Gauteng Province: Surface Water Impact Assessment (2013);
 - Proposed Construction of an 11kV Underground Power Cable from Civic Centre to Zola Substation, Gauteng Province: Wetland Assessment (2013);
 - Proposed Construction of a Substation on Portion 265 Randjesfontein 405-JR, Gauteng Province; Wetland Delineation and Impact Assessment (2013);
 - Proposed Re-build of a Section of the Mathibestad Danhauser 33kV Power Line Network, North West Province: Wetland Assessment (2013);
 - Proposed Re-build of a Section of the Existing 33kV Mathibestad-Danhauser Power Line Network, Gauteng Province: Surface Water Impact Assessment (2013);
 - Proposed Re-build of a Section of the Existing 33kV Mothutlung North Power Line Network, Gauteng Province: Surface Water Impact Assessment (2013);
 - Proposed Re-build of a Section of the Existing 33kV Mothutlung South Power Line Network, Gauteng Province: Surface Water Impact Assessment (2013);
 - Proposed Re-build of a Section of the Existing 33kV Nonyane Madidi North Power Line Network, Gauteng Province: Surface Water Impact Assessment (2013);
 - Proposed Re-build of a Section of the Existing 33kV Nonyane Swartdam Power Line Network, Gauteng Province: Surface Water Impact Assessment (2013);
 - Proposed Rebuild of a Section of the Existing 33kV Pelly Klipdrift Network, Gauteng and North West Provinces: Surface Water Impact Assessment (2013);
 - Proposed Re-build of a Section of the Existing 33kV Zonderwater Kraal Power Line Network, Gauteng Province: Surface Water Impact Assessment (2013);
 - Proposed Re-build of a Section of the Existing 33kV Hammanskraal Lusthof Power Line Network, Gauteng Province: Surface Water Impact Assessment (2013);
 - Proposed Re-build of a Section of the Existing 33kV Klipgat Circle Power Line Network, Gauteng Province: Wetland Assessment (2013);
 - Proposed Re-build of Sections of the Existing 33kV Erasmus Aviva Power Line Network, Gauteng Province: Surface Water Assessment (2013);
 - Proposed Construction of an 11kV Underground Power Cable at the Ga-Rankuwa Substation, Gauteng Province: Wetland Assessment (2013);
 - Mamatwan Manganese Mine, Northern Cape Province: Surface Water Assessment (2014);

-
- Two 5MW Photovoltaic Plants, Free State Province: Surface Water Assessment (2014);
 - Dwarsrug Wind Farm, Northern Cape Province: Surface Water Assessment (2014);
 - Manzimtoti Sewer Line Project, Kwa-Zulu Natal Province: Surface Water Assessment (2014);
 - Compensation Flats Development, Kwa-Zulu Natal Province: Surface Water Assessment (2014);
 - Tinley Manor South Road Development, Kwa-Zulu Natal Province: Surface Water Assessment (2014);
 - Ntuzuma Sewer Line Project, Kwa-Zulu Natal Province: Surface Water Assessment (2014);
 - Esphiva Sewer Line Project, Kwa-Zulu Natal Province: Surface Water Assessment (2014);
 - Frankfort 132kV Power Line Wetland Walk-down Assessment, Free State Province (2014);
 - Proposed Construction of the Esphiva Water Pipeline near Ulundi, KwaZulu-Natal Province: Surface Water Assessment (2014);
 - Grootvlei Power Station Wetland Assessment, Mpumalanga Province (2014/2015);
 - Proposed Construction of the Embangweni and Bhekabantu Irrigation Schemes, KwaZulu-Natal Province: Wetland and Aquatic Assessment (2015);
 - Proposed Construction of the Nondabuya and Khwehle Primary Agriculture Schemes, KwaZulu-Natal Province: Wetland and Aquatic Assessment (2015);
 - Proposed Expansion of the Makhathini Irrigation Scheme, KwaZulu-Natal Province: Wetland and Aquatic Assessment (2015);
 - Proposed Construction of the Mbaliyezwe Irrigation Schemes, KwaZulu-Natal Province: Wetland and Aquatic Assessment (2015);
 - Proposed Mixed Use Development on the Remainder of Portion 27 of the Farm Middelburg Town and Townlands 287 JS, Steve Tshwete Local Municipality in the Mpumalanga Province: Wetland Assessment (2015);
 - Proposed Construction of Two Power Lines and Two Substations for the Mainstream Wind Facilities near Beaufort West, Western Cape Province: Surface Water Assessment (2015);
 - Proposed eThekweni Integrated Rapid Transport Network (IRPTN) – Bus Rapid Transport (BRT) Phase 1: Route C1A, KwaZulu-Natal Province: Wetland Assessment (2015);
 - Proposed Coal Railway Siding at the Welgedacht Marshalling Yard and associated Milder Road Upgrade near Springs, Gauteng Province: Wetland Assessment (2015);
 - Proposed Development of a 22kV Medium Voltage Power Line in Mofofutso, North West Province: Surface Water Assessment (2015);
 - Mookodi Integration Power Line Project, North West Province: Wetland Walk-down Assessment (2015);
 - Proposed Construction of a Coal Loading Facility within the existing Bronkhorstspuit Railway Siding near Bronkhorstspuit, Gauteng Province (2015);
 - Proposed Construction of the Two 75MW Tlisitseng Solar Photovoltaic Energy Facilities near Lichtenburg, North West Province: Surface Water Assessment (2015);
 - Proposed Construction of the Tlisitseng Solar Substation and associated 400kV Power Line near Lichtenburg, North West Province: Surface Water Assessment (2015);
 - Proposed Construction of the Two 75MW Sendawo Solar Photovoltaic Energy Facilities near Lichtenburg, North West Province: Surface Water Assessment (2015);
 - Proposed Construction of the Sendawo Solar Substation and associated 400kV Power Line near Lichtenburg, North West Province: Surface Water Assessment (2015);
 - Proposed Construction of a 75MW Solar Photovoltaic Power Plant near Dennilton, Limpopo Province: Surface Water Assessment (2015);
 - Proposed Construction of the Helena 1, 2 & 3 Photovoltaic Energy Facilities near Copperton, Northern Cape Province: Surface Water Assessment (2015);
 - Proposed Construction of a 70MW Photovoltaic Facility and 132kV Power Line near Loeriesfontein, Northern Cape Province: Surface Water Assessment (2015);
 - Proposed Construction of the Eureka West 140MW Wind Farm near Copperton, Northern Cape Province: Surface Water Assessment (2016);
 - Proposed Construction of the Eureka East 140MW Wind Farm near Copperton, Northern Cape Province: Surface Water Assessment (2016);

CURRICULUM VITAE

Shaun Taylor

- Proposed Construction of the Eureka 132kV Power Line near Copperton, Northern Cape Province: Surface Water Assessment (2016);
- Proposed Construction of the Aletta 140MW Wind Farm near Copperton, Northern Cape Province: Surface Water Assessment (2016).

WETLAND AND RIPARIAN REHABILITATION / POST-REHABILITATION / AUDITING ASSESSMENTS

- Post-rehabilitation Assessment of Three Wetland Crossing Sites for Chemwes (Pty) Ltd for the Re-working of a Tailings Dam Project near Stilfontein, North West Province (2011);
- Fourways 22kV Feeder Cable Wetland and River Rehabilitation Plan (2011);
- Post-rehabilitation Assessment of the Inland New Multi-Purpose Pipeline in the Mpumalanga and Gauteng Provinces (2012);
- John Ross Highway Wetland Rehabilitation Plan, KwaZulu-Natal Province (2014);
- Proposed eThekweni Integrated Rapid Transport Network (IRPTN) – Bus Rapid Transport (BRT) Phase 1: Route C1A, KwaZulu-Natal Province: Wetland and Riparian Rehabilitation Plan (2015).

ENVIROKEY CC - JUNIOR ENVIRONMENTAL CONSULTANT AND GIS SUPPORT - OCT 2009 – MAR 2010

Responsible for managing basic assessments, report writing, conducting specialist wetland assessments, auditing procedures and GIS mapping. Full list of activities completed available on request.

JUNIOR ENVIRONMENTAL CONSULTANT AUG 2007 – SEP 2009

Responsible for managing basic assessments, report writing, conducting specialist wetland assessments, environmental auditing procedures and GIS mapping. Full list of activities completed available on request.

Conferences and Publications

Taylor, S. R., 2008: A Critical Review of Strategic Environmental Assessment in South Africa and looking towards Future Considerations, presented at the South African Students Geography Conference, University of Cape Town, Cape Town.

Academic and Work Related Achievements

- Awarded Monash Dean's recognition award for outstanding academic results for second semester of 2006;
- Awarded Monash Dean's recognition award for outstanding academic results for first semester of 2007;
- Awarded Monash Dean's recognition award for outstanding academic results for second semester of 2007;
- Awarded Golden Key membership and certificate to the International Honours Society for outstanding academic achievements in undergraduate studies for Monash 2008;
- Awarded Study Sponsorship from Holgate, Meyer and Associates for Honours study in 2008/09;
- Awarded Certificate of Merit from University of Witwatersrand for outstanding work for the course of Honours in 2009/10;
- Awarded Merit Bursary for MSc from the University of Johannesburg 2010 for excellent academic results;
- Numerous short-course certificates (grass identification, wildflower identification, veld management, wetland buffer assessments and water use licensing).

CURRICULUM VITAE

Kerry Lianne Schwartz

Name	Kerry Lianne Schwartz
Profession	GIS Specialist
Name of Firm	SiVEST SA (Pty) Ltd
Present Appointment	Senior GIS Consultant: Environmental Division
Years with Firm	24 Years
Date of Birth	21 October 1960
ID No.	6010210231083
Nationality	South African



Professional Qualifications

BA (Geography), University of Leeds 1982

Employment Record

1994 – Present	SiVEST SA (Pty) Ltd - Environmental Division: GIS/Database Specialist.
1988 - 1994	SiVEST (formerly Scott Wilson Kirkpatrick): Town Planning Technician.
1984 – 1988	Development and Services Board, Pietermaritzburg: Town Planning Technician.

Language Proficiency

LANGUAGE	SPEAK	READ	WRITE
English	Fluent	Fluent	Fluent

Key Experience

Kerry is a GIS specialist with more than 16 years experience in the application of GIS technology in various environmental, regional planning and infrastructural projects undertaken by SiVEST.

Kerry's GIS skills have been extensively utilised in projects throughout South Africa in other Southern African Countries. These projects have involved a range of GIS work, including:

- Design, compilation and management of a demographic, socio-economic, land use, environmental and infrastructural databases.
- Collection, collation and integration of data from a variety of sources for use on specific projects.
- Manipulation and interpretation of both spatial and alphanumeric data to provide meaningful inputs for a variety of projects.
- Production of thematic maps and graphics.
- Spatial analysis and 3D modelling, including visual and landscape assessments.

Projects Experience

STRATEGIC PLANNING PROJECTS

Provision of database, analysis and GIS mapping support for the following:

- Water Plan 2025: Socio-economic, Land Use and Demographic Update – Umgeni Water (KwaZulu-Natal).
- Eskom Strategic Plan – Eskom (KwaZulu-Natal).
- Umgeni Water Quality Management Plan – Department of Water Affairs and Umgeni Water (KwaZulu-Natal).
- KwaZulu-Natal Development Perspective – Department of Economic Affairs (KwaZulu-Natal).
- Indlovu Regional Integrated Plan – Department of Local Government and Housing (KwaZulu-Natal).
- Umgeni Water and Sanitation Needs Analysis – Umgeni Water (KwaZulu-Natal).
- Metro Waste Water Management Plan – Durban Waste Water management, City of Durban (KwaZulu-Natal).
- KwaZulu-Natal Electrification Prioritisation Model – Eskom (KwaZulu-Natal).
- Umzinyathi Regional Development Plan – Umzinyathi Regional Council (KwaZulu-Natal).
- GIS driven model to assess future population growth in quaternary catchments under different growth scenarios – Umgeni Water (KwaZulu-Natal).
- Ubombo Master Water Plan Study – Mhlathuze Water Board (KwaZulu-Natal).
- Development strategy for local economic development and social reconstruction of the Germiston-Daveyton Activity Corridor – Eastern Gauteng Services Council (Gauteng).
- Structure Plan for the Cities of Beira and Dondo in Mozambique – World Bank.
- Land identification study for low cost housing in the Indlovu Region – Indlovu Regional Council (KwaZulu-Natal).
- Local Development Plan for Manzini – Manzini Town Council (Swaziland).
- Indlovu Project Prioritisation Model – Indlovu Regional Council (KwaZulu-Natal).
- Structure Plans for the Cities of Ndola and Luanshya - Ministry of Local Government and Housing (Zambia).
- Database development for socio-economic and health indicators arising from Social Impact Assessments conducted for the Lesotho Highlands Development Association – Lesotho.
- Development Plan for the adjacent towns of Kasane and Kazungula - Ministry of Local Government, Land and Housing (Botswana).
- Development Plan for the rural village of Hukuntsi - Ministry of Local Government, Land and Housing (Botswana).
- Provision of data platform for the spatial analysis of water supply, demand and affordability in Bulawayo – City of Bulawayo and NORAIID (Zimbabwe).
- Integrated Development Plans for various District and Local Municipalities including:
 - Nquthu Local Municipality (KwaZulu-Natal)
 - Newcastle Local Municipality (KwaZulu-Natal)
 - Amajuba District Municipality (KwaZulu-Natal)
 - Jozini Local Municipality (KwaZulu-Natal)
 - Umhlabuyalingana Local Municipality (KwaZulu-Natal)
- uMhlathuze Rural Development Initiative – uMhlathuze Local Municipality (KwaZulu-Natal).
- Rural roads identification – uMhlathuze Local Municipality (KwaZulu-Natal).
- Mapungubwe Tourism Initiative – Development Bank (Limpopo Province).
- Northern Cape Tourism Master Plan – Department of Economic Affairs and Tourism (Northern Cape Province).

- Spatial Development Framework for Gert Sibande District Municipality (Mpumalanga) in conjunction with more detailed spatial development frameworks for the 7 Local Municipalities in the District, namely:
 - Albert Luthuli Local Municipality
 - Msukaligwa Local Municipality
 - Mkhondo Local Municipality
 - Pixley Ka Seme Local Municipality
 - Dipaleseng Local Municipality
 - Govan Mbeki Local Municipality
 - Lekwa Local Municipality
- Land Use Management Plans/Systems (LUMS) for various Local Municipalities including:
 - Nkandla Local Municipality (KwaZulu-Natal)
 - Hlabisa Local Municipality (KwaZulu-Natal)
 - uPhongolo Local Municipality (KwaZulu-Natal)
 - uMshwathi Local Municipality
- Spatial Development Framework for uMhlathuze Local Municipality (KwaZulu-Natal).
- Spatial Development Framework for Greater Clarens – Maloti-Drakensberg Transfrontier Park (Free State).
- Local Spatial Development Framework for Brackenhurst and Brackendowns (Region 10) – Ekurhuleni Metropolitan Municipality (Gauteng).
- Housing Sector Plan – Ntambanana Local Municipality (KwaZulu-Natal).
- Land use study for the Johannesburg Inner City Summit and Charter – City of Johannesburg (Gauteng).
- Ezikhawini-Vuindlela Corridor study – uMhlathuze Local Municipality (KwaZulu-Natal).
- Port Durnford and Ezikhawini Rural Node study - uMhlathuze Local Municipality (KwaZulu-Natal).
- Port of Richards Bay Due Diligence Investigation – Transnet
- Jozini Sustainable Development Plan – Jozini Local Municipality (KwaZulu-Natal)
- Spatial Development Framework for Umhlabuyalingana Local Municipality (KwaZulu-Natal)

BUILT INFRASTRUCTURE

- Construction Environmental Management Plan for transmission lines from Zeus substation to Mercury substation – Eskom.
- EIA and EMP for a 9km railway line and water pipeline for manganese mine – Kalagadi Manganese (Northern Cape Province).
- EIA and EMP for 5x 440kV Transmission Lines between Thyspunt (proposed nuclear power station site) and several substations in the Port Elizabeth area – Eskom (Eastern Cape Province).
- Environmental Impact Assessment for turn in lines and substation upgrading for Malelane substation – Eskom (Mpumalanga Province).
- Initial Scoping for the proposed 750km multi petroleum products pipeline from Durban to Gauteng/Mpumalanga – Transnet Pipelines.
- Detailed EIA for multi petroleum products pipeline from Kendall Waltloo, and from Jameson Park to Langtaagte Tanks farms –Transnet Pipelines.
- Environmental Management Plan (operational management plan) including visual impact assessment, noise impact assessment and flight path determination for the commercialization of Skukuza Airport – SANParks (Mpumalanga Province).
- Environmental Management Plan for copper and cobalt mine (Democratic Republic of Congo).
- EIA and Agricultural Feasibility study for Miwani Sugar Mill (Kenya).
- EIAs for Concentrated Solar and Photovoltaic power plants (Northern Cape).

- EIAs for Wind Farms (Northern Cape).
- EIAs for 132kV Distribution Lines in North West Province.

STATE OF THE ENVIRONMENT REPORTING

- 2008 State of the Environment Report for City of Johannesburg.
- Biodiversity Assessment – City of Johannesburg.

STRATEGIC ENVIRONMENTAL ASSESSMENTS AND ENVIRONMENTAL MANAGEMENT FRAMEWORKS

- SEA for Greater Clarens – Maloti-Drakensberg Transfrontier Park (Free State).
- SEA for the Marula Region of the Kruger National Park, SANParks.
- SEA for Thanda Private Game Reserve (KwaZulu-Natal).
- SEA for KwaDukuza Local Municipality (KwaZulu-Natal).
- EMF for proposed Renishaw Estate (KwaZulu-Natal).
- EMF for Mogale City Local Municipality, Mogale City Local Municipality (Gauteng).

WETLAND STUDIES

- Rehabilitation Planning for the Upper Klip River and Klipspruit Catchments, City of Johannesburg (Gauteng).
- Wetland Delineation and Assessment for the proposed Eskom CCGT Power Plant near Majuba Power Station – Eskom (Mpumalanga).

VISUAL IMPACT ASSESSMENTS

- Visual Impact Assessment for the proposed relocation of the Skukuza Conference Centre, SANParks.
- Visual Impact Assessment for the proposed re-commercialisation of the Skukuza Airport.
- Visual Impact Assessment for the proposed development of residential apartments in Ramsgate, KZN.
- Visual Impact Assessment for the redevelopment of the Newmarket Racecourse, Alberton, Gauteng
- Visual Impact Assessment for the Thyspunt Transmission Lines Integration Project
- Visual Impact Assessments for 5 Solar Power Plants in the Northern Cape
- Visual Impact Assessments for 2 Wind Farms in the Northern Cape
- Visual Impact Assessment for Mookodi Integration Project (132kV distribution lines)
- Landscape Character Assessment for Mogale City Environmental Management Framework

Name Lynsey Rimbault

Profession Environmentalist

Name of Firm SiVEST SA (Pty) Ltd

Present Appointment Environmental Consultant:
SiVEST Environmental Division

Years with Firm since August 2014

Date of Birth 10 April 1989

ID Number 8904100104087

Nationality South African



Education

Matriculated 2007 (with distinction), Full Academic Colours, Hyde Park High School, Johannesburg, South Africa

Professional Qualifications

MSc Biodiversity, Conservation and Management (University of Oxford 2012-2013)
BSc (Hons) Geography (University of the Witwatersrand 2011)
BA Geography and English (University of the Witwatersrand 2008-2010)

Employment Record

Aug 2014 – to date SiVEST Environmental Division: Trainee Environmental Consultant
Feb 2014 – July 2014 Kulima Integrated Development Solutions
Jan 2012 – June 2012 Rayten Engineering Solutions

Language Proficiency

LANGUAGE	SPEAK	READ	WRITE
English	Fluent	Fluent	Fluent

Key Experience

Specialising in the field of Environmental Management.

Lynsey joined SiVEST in August 2014 and holds the position of Environmental Consultant in the Johannesburg Office. She has 1 year of work experience and is specialising in the management and compilation of Environmental Impact Assessments (EIAs) and Basic Assessment (BAs) primarily related to energy generation and electrical distribution projects.

Lynsey has worked previously for Kulima Integrated Development Solutions conducting research for a NEPAD project on Agricultural Adaptations to Climate Change. This involved four different farming sectors in four different provinces of South Africa. Prior to this Lynsey worked at Rayten Engineering Solutions in the field of air quality consulting, primarily in the mining sector.

Her academic achievements include; full academic colours in high school, elected prefect, Grade 11 dux scholar and four distinctions in matric. She is a member of the Golden Key International Honour Society for academic achievement. In her undergraduate degree she was top student in first and second year. During her Honours year she was awarded a post graduate merit award for excellence in academic performance. Lynsey was the recipient of the Allan and Nesta Ferguson Trust Scholarship for tuition at the University of Oxford.

Computer Literacy

Proficient in Microsoft Office,
ArcGIS,
IDRISI,
QGIS.

Projects Experience

Aug 2014 – to date

ENVIRONMENTAL IMPACT ASSESSMENT (EIA) / BASIC ASSESSMENT (BA)

- Basic Assessment for the Ermelo-Richards Bay Coal Line Upgrade Project: Proposed development of the Madlanzini Main Transmission Station and Associated 88kV and 400kV turn in power lines, Mpumalanga Province.
- Environmental Impact Assessment for the proposed development of the Dwarsrug Wind Farm near Loeriesfontein, Northern Cape Province.
- Basic Assessment for the proposed Construction of the Mookodi Integration Phase 2 132kV Power Line from the Mookodi MTS to the new proposed Ganyesa Substation, North West Province.
- Environmental Impact Assessment for the proposed construction of the Nokukhanya Solar Photovoltaic Power Plant near Dennilton, Limpopo Province.

OTHER

- Environmental Scoping and Appraisal, as part of the SMEC Consortium, during the feasibility study for the Gautrain Extensions Project
- Authority Consultation and Environmental Screening Assessment for the proposed Lombardy East Housing Development, Gauteng Province.
- Application for Flora Permits for the removal and relocation of vegetation species for the Khobab and Loeriesfontein Wind Farm power line corridors.

Feb 2014 – July 2014

Conducting research on adoption of agricultural adaptation practices to climate change in four provinces of South Africa, through primary fieldwork and qualitative data collection. Research conducted under the auspices of the Comprehensive Africa Agriculture Development Programme (CAADP), a NEPAD programme. The research objective was to integrate and implement adaptation to climate change issues into agricultural development strategies.

- Identifying through specific entry points and snowball sampling at least 20 farmers per commodity group and location
- Conducting qualitative interviews with farmers on their farms or at other mutually agreed locations
- Identifying and interviewing any relevant local stakeholders
- Providing comprehensive notes on interviews, highlighting themes explored and emerging answers
- Providing final reports on each of the commodity groups explored and scorecards elaborating each adaptation observed.

Jan 2012 – June 2012

Environmental Scientist, responsible for air quality monitoring, project management dispersion modelling and air quality impact assessments, monitoring station siting for the Department of Environmental Affairs.

CURRICULUM VITAE: D G Paterson

SURNAME: PATERSON
FIRST NAME(S): David Garry
KNOWN AS: Garry
DATE OF BIRTH: 25-08-1959 in Bellshill, Scotland
NATIONALITY: South African
I.D. No.: 5908255258088
LANGUAGE PROFICIENCY: English, Afrikaans (both fluent), French (poor)
MARITAL STATUS: Married, one son

ADDRESS: Institute for Soil, Climate and Water **TEL.:** (012) 310 2601
Private Bag X79 083 556 2458
Pretoria 0001
Republic of South Africa **FAX:** (012) 323 1157

E-MAIL ADDRESS: garry@arc.agric.za

ACADEMIC QUALIFICATIONS:

- Matriculated: 1976, Dalziel High School, Motherwell, Scotland
- BSc (Hons) Geography, 1980, University of Strathclyde, Glasgow, Scotland
- MSc (Soil Science) *cum laude*, 1998, University of Pretoria

PROFESSIONAL CAREER:

- 1981-1987: Soil Scientist: Soil and Irrigation Research Institute, Pretoria
- 1987-1992: Senior Soil Scientist: Soil and Irrigation Research Institute, Pretoria
- 1992-present: Senior Soil Scientist: ARC-Institute for Soil, Climate & Water

FIELDS OF SPECIALITY AND COMPETENCE:

- Soil classification and mapping
- Soil interpretations
- Soil survey project management
- Environmental assessment
- Soil survey and land capability course presentation
- Ground penetrating radar

PUBLICATIONS (see attached list):

- Three refereed articles (S.A. Journal of Plant and Soil)
- Nine Congress papers/posters
- S.A. Soil Classification (1991) (Member of working group)
- Seven 1:250 000 Land Type Maps
- Three Land Type Memoirs
- More than 200 soil survey reports and/or maps

COURSES COMPLETED:

- Course in Project Management (University of Stellenbosch)
- Course in Junior Personnel Management (Dept of Agriculture)
- Course in Handling of Grievances and Complaints (Dept of Agriculture)
- Course in Marketing (ARC-ISCW)
- Course in National Qualifications Framework Assessment, ARC-CO
- Training Course in Ground Penetrating Radar (GSSI, USA)
- Introduction to ArcGIS 8, GIMS, 2004

PROFESSIONAL STATUS:

- Registered Natural Scientist: Soil Science (SA National Council for Natural Scientific Professions) – registration number 400463/04
- Member of South African Soil Classification Working Group, 1990-present
- Convenor of South African Soil Classification Working Group, 2013-
- Member of Soil Science Society of South Africa (1982-present)
- President of Soil Science Society of South Africa (2005-2007)
- Member of South African Soil Survey Organisation (2000-present)
- Council Member of South African Soil Survey Organisation (2002-2003)
- Member of International Erosion Control Association
- Scientific Referee, S.A. Journal for Plant and Soil
- External Examiner, University of Pretoria, University of Witwatersrand, University of Venda

AWARDS:

Best article on Soil Science, South African Journal for Plant and Soil, 2011

MISCELLANEOUS:

- Editor, Soil Science Society newsletter, 1993-present
- Member, Clapham High School (Pretoria) Governing Body 1998-2002
- Member, Northern Gauteng Football Referee's Association
- Committee Member, Rosslyn Golf Club (Club Champion 2002 and 2007)

INTERESTS:

Sport, especially golf and soccer; wildlife; reading; music

REFEREES:

Mr T.E. Dohse, ARC-Institute for Soil, Climate and Water.
Tel: (012) 310-2504; 082 324 5389

Prof A.S. Claassens, Faculty of Plant Production and Soil Science, University of Pretoria
Tel: (012) 420-3213; 084 581 6488

Prof M.C. Laker (retired), (012) 361-2900; 082 785 5295

PUBLICATIONS LIST:

Refereed Articles:

BÜHMANN, C., KIRSTEN, W.F.A., PATERSON, D.G. & SOBCZYK, M.E., 1993. Pedogenic differences between two adjacent basalt-derived profiles. 1. Textural and chemical characteristics. *S. Afr. J. Plant & Soil*, 10: 155-161

BÜHMANN, C., KIRSTEN, W.F.A., PATERSON, D.G. & SOBCZYK, M.E., 1994. Pedogenic differences between two adjacent basalt-derived profiles. 2. Mineralogical characteristics. *S. Afr. J. Plant & Soil*, 11: 5-11

PATERSON, D.G. & LAKER, M.C., 1999. Using ground penetrating radar to investigate spoil layers in rehabilitated mine soils. *S. Afr. J. Plant & Soil*, 16:131-134.

PATERSON, D.G., BÜHMANN, C., PIENAAR, G.M.E. & BARNARD, R.O., 2011. Beneficial effect of palm geotextiles on inter-rill erosion in South African soils and mine dam tailings: a rainfall simulator study. *S. Afr. J. Plant & Soil*, 28: 181-189.

PATERSON, D.G. & BARNARD, R.O., 2011. Beneficial effect of palm geotextiles on inter-rill erosion in South African soils. *S. Afr. J. Plant & Soil*, 28: 190-197.

Books:

PATERSON, D.G. & MUSHIA, N.M., 2011. Soil databases in Africa. *In: Handbook of Soil Science (2nd Edn)*. Ed. M.E. Sumner. Taylor & Francis, Boca Raton FL.

SOIL CLASSIFICATION WORKING GROUP*, 1991. Soil classification. A taxonomic system for South Africa. Institute for Soil, Climate & Water, Pretoria.

* Co-author as member of Working Group

Thesis:

PATERSON, D.G., 1998. The use of ground penetrating radar to investigate subsurface features in selected South African soils. Unpublished M Sc Thesis, University of Pretoria.

Congress Papers:

PATERSON, D.G., 1987. The relationship between geology and soil type in the northern Kruger National Park. 14th Congress of the Soil Science Society of S.A. Nelspruit, 14-17 July 1987.

PATERSON, D.G., 1990. A study of black and red clay soils on basalt in the northern Kruger National Park. 16th Congress of the Soil Science Society of S.A. Pretoria, 9-12 July 1990.

PATERSON, D.G., 1992. The potential of ground penetrating radar as an aid to soil investigation. 17th Congress of the Soil Science Society of S.A. Stellenbosch, 28-30 Jan.1992.

PATERSON, D.G., 1995. The complex soil mantle of South Africa. ARC Wise Land Use Symposium, Pretoria, 26-27 Oct. 1995

PATERSON, D.G. & LAKER, M.C., 1998. Locating subsoil features with ground penetrating radar. 21st Congress of the Soil Science Society of S.A. Alpine Heath, 20-22 Jan. 1998.

PATERSON, D.G., 2000. Mapping rehabilitated coal mine soils in South Africa using ground penetrating radar. Eighth International Conference on Ground Penetrating Radar, Gold Coast, Australia, 23-26 May 2000.

PATERSON, D.G. & VAN DER WALT, M., 2003. The soils of South Africa from the Land Type Survey. 24th Congress of the Soil Science Society of S.A., Stellenbosch, 20-24 Jan. 2003

Land Type Maps:

PATERSON, D.G., 1990. 1:250 000 scale land type map 2230 Messina. Dept. Agriculture, Pretoria.

PATERSON, D.G. & HAARHOFF, D., 1989. 1:250 000 scale land type map 2326 Ellisras. Dept. Agriculture, Pretoria.

PATERSON, D.G., PLATH, B.L. & SMITH, H.W., 1987. 1:250 000 scale land type map 2428 Nylstroom. Dept. Agriculture, Pretoria.

PATERSON, D.G. & ROSS, P.G., 1989. 1:250 000 scale land type map 2330 Tzaneen. Dept. Agriculture, Pretoria.

PLATH, B.L. & PATERSON, D.G., 1987. 1:250 000 scale land type map 2426 Thabazimbi. Dept. Agriculture, Pretoria.

Land Type Memoirs:

PATERSON, D.G., PLATH, B.L. & SMITH, H.W., 1988. Field Investigation. In: *Land types of the maps 2426 Thabazimbi & 2428 Nylstroom. Mem. Agric. Nat. Res. S. Afr.* No. 10. Dept. Agriculture, Pretoria.

PATERSON, D.G., SCHOEMAN, J.L., TURNER, D.P., GEERS, B.C. & ROSS, P.G., 1989. Field Investigation. In: *Land types of the maps 2330 Tzaneen & 2430 Pilgrim's Rest. Mem. Agric. Nat. Res. S. Afr.* No. 12. Dept. Agriculture, Pretoria.

PATERSON, D.G., 1999. 1:250 000 land type survey of the former Ciskei (Unpublished). ISCW Report GW/A/99/24.

Also:

PATERSON, D.G., 1992. Ground penetrating radar applications in USA and South Africa. Report on an official study tour to USA, 13-29 July, 1991. ISCW Report GW/A/92/8

PATERSON, D.G., 2000. Report on official overseas visit to GPR2000 Conference, Broadbeach, Australia, 23-26 May, 2000. ISCW Report GW/A/2000/40

Plus ARC-ISCW Reports on:

- Ground penetrating radar investigations in: Kruger National Park; Enseleni, Natal; Weatherly, Maclear; Kleinkopje Mine

- Soil survey investigations at: Roodeplaat, Kathu, Steelpoort River, Palala River, Zeekoegat (Roodeplaat), Limpopo River, Lydenburg, Kendal, Clewer Sand (Witbank), Botha Sand (Witbank), Balmoral Colliery, Bafokeng (Rustenburg), Towoomba (Warmbaths), Hoefeld Stene (Middelburg), Quality Bricks (Witbank), Visagie Sand (Middelburg), Rosslyn, Coalbrook (Sasolburg), Stewart Coal (Delmas), Forzando Coal (Hendrina), Vaalgro (Vereeniging), Ratanda (Heidelberg), Elspark (Boksburg), Thornccliffe Mine (Steelpoort), Jan Smuts Quarry (Boksburg), Ennerdale (Phase I & II), Thokoza, North Riding, Natalspruit (Alberton), Arnot, Kroondal (Phase I & II), Ga-Rankuwa, Hartebeespoort Dam, Kosmos, Assen, Grasmere, Magalies Moot (Pretoria), Valpre (Paulpietersburg), Cargo Carriers (Sasolburg), Waterval (Rustenburg), Rayton, Bronkhorstspuit, Zwavelpoort (Pretoria), Pietersburg, Trojan Mine (Steelpoort), Platinum Highway (Rustenburg), Moutse, Centurion, Salique (Klaserie), Northam, Greenside Colliery (Witbank), South Deep Mine (Westonaria), Bank Colliery, Steelpoort Platinum, Gautrain Route (Pta/Jbg), Rietspruit Mine (Ogies), Potgietersrus Platinum, Atok Mine (Lebowa), Blue Ridge Mine (Groblersdal), Ngodwana, Estancia (Breyton), Twickenham Mine (Steelpoort), Marikana

Memory Madondo

Date of Birth: 17 August 1986
Profession: Development Economist
Specialisation: Innovation and Sustainable Development
Years within Firm: 4 Years
Nationality: RSA
Years of Experience: 4 Years
HDI Status: Black Female



Education:

2011 – 2013, University of South Africa	BSc: Mathematical Statistics
2009, University of Pretoria	BSc: Mathematical Statistics (<i>not completed</i>)
2006-2008, University of Pretoria	BCom: Statistics

Professional Membership:

Development of Society of Southern Africa
South African Planning Institute

Language Proficiency:	Reading	Writing	Speaking
English	Excellent	Excellent	Excellent
Zulu	Average	Average	Poor
Shona	Poor	Poor	Average

Key Qualification

Memory Madondo completed a BSc degree in Mathematical Statistics from the University of South Africa in 2013, her majors being Mathematics and Statistics. She also holds a BCom in Statistics from the University of Pretoria. She is fully computer literate including computerised statistics (which is referred to as SAS – Statistical Analysis System), Structured Query Language (SQL) and MS Access Database Management. Her interests lie in statistical analysis and any numerical challenges.

Memory joined Urban-Econ in 2011 as a Technical Assistant working on the company’s electronic database system and gradually started assisting with some projects. She has gained experience in several economic arenas such as collation and analytic processing of economic data, trend analysis, forecasting and economic development amongst others. She has also carried out a number of socio-economic impact assessments of varying magnitude and has in turn gained good skill in report writing and presentation. She continues to gain further knowledge as well as expertise in the economic field.

Experience Record

Project: Waterval East Filling Station Study Year: 2012 Location: Rustenburg Client: Private Project Features: ✓ Provide an understanding of local market area Position held: ✓ Analysis of the local market’s potential to absorb the proposed development Activities Performed: Researcher Feasibility study
Project: NC Renewable Energy Year: 2012 Location: Northern Cape Client: Northern Cape Department of Economic Development and Tourism Project Features: ✓ Description of the status and potential of the local renewable energy sector ✓ Investigation of the potential to establish clean and green sustainable development projects in the Province in line with the optimal mix identified.

Position held:	Researcher
Activities Performed:	Strategy and implementation plan formulation
Project:	Lesedi and Letsatsi Community Needs Analysis
Year:	2013/2014
Location:	Northern Cape and Free State
Client:	Lesedi Power Company and Letsatsi Power Company (Solar Reserve)
Project Features:	<ul style="list-style-type: none"> ✓ Description of the status and potential of the local renewable energy sector ✓ Investigation of the potential to establish clean and green sustainable development projects in the Province in line with the optimal mix identified.
Position held:	Researcher
Activities Performed:	Strategy and implementation plan formulation
Project:	NC Renewable Energy
Year:	2015
Location:	Northern Cape
Client:	Northern Cape Department of Economic Development and Tourism
Project Features:	<ul style="list-style-type: none"> ✓ Description of the status and potential of the local renewable energy sector ✓ Investigation of the potential to establish clean and green sustainable development projects in the Province in line with the optimal mix identified.
Position held:	Researcher
Activities Performed:	Strategy and implementation plan formulation

Other Projects:

- Merafong Economic Summit Spin-Off: Urban-Econ: Development Economics was appointed response by the Merafong Local Municipality to assist in developing an Economic summit discussion document with possible action plan. The objectives of the assistance to be provided by Urban-Econ are among others; to identify local business needs and fatal flaws, to package a discussion document that will serve as a guideline for the session while providing direction to the participants and to provide directional guidelines to address the summit outcomes in a pro-active manner.
- Zonnebloem Comparative Analysis: Urban-Econ Development Economists was appointed by Golder Associates to undertake an economic impact assessment study for the proposed Zonnebloem Coal Mine situated near Middelburg in the Mpumalanga Province. The included providing a baseline profile of the study area - analysis of parameters such as population size, household numbers, income levels, structure and growth of the economy, labour force and employment situation.
- Nelson Mandela Scoping: Urban-Econ Development Economists was appointed to undertake a specialist market analysis as part of planning for provision of infrastructure to the Nelson Mandela Bay Metropolitan Municipality. The primary objective of this study was to identify the growth rates and anticipated number of households per demand zone within the Nelson Mandela Bay Metropolitan Municipality to gain insight on the Metro's infrastructural needs.
- Savanna Cookware Prefeasibility Study: Urban-Econ Development Economists was appointed by Savanna Collection and Runitrax Investments to undertake a pre-feasibility study of establishing a stainless steel cookware manufacturing facility in South Africa. The key aspects that were set to be determined during the pre-feasibility study included, inter alia; the need and desirability for the proposed manufacturing facility, the key prerequisites for the viability of the proposed venture and the most optimal location for the proposed manufacturing facility.
- Exarro Power Station SEIA: Urban-Econ Development Economists was requested by Savannah Environmental (Pty) Ltd. (Savannah Environmental) to undertake a Socio-Economic Impact Study for the proposed Exxaro coal-powered power station near the town of Lephalale, the Limpopo province. This study presented the analysis of socio-economic impacts that are expected to ensure from the proposed project during various stages of the project's life cycle and considering both positive and negative effects.
- Lesedi and Letsatsi Community Needs Analysis: Urban-Econ Development Economists was requested by Lesedi/Letsatsi Power Company to design Economic Development and Enterprise development programmes that speaks to the scope of Lesedi/Letsatsi's compliance commitments with regard to the identification of the implementable socio-economic development and enterprise development initiatives that can be considered for implementation once the power plant is operational. The scope of work involved development of comprehensive profiles of the selected communities, identification of their needs, assessment of business opportunities and provision of recommendations with regard to the initiatives that could be implemented to address the gaps.
- Zonnebloem Comparative Analysis: Urban-Econ Development Economists was appointed by Golder Associates to undertake an economic impact assessment study for the proposed Zonnebloem Coal Mine situated near Middelburg in the Mpumalanga

Province. The included providing a baseline profile of the study area - analysis of parameters such as population size, household numbers, income levels, structure and growth of the economy, labour force and employment situation.

- Nelson Mandela Scoping: Urban-Econ Development Economists was appointed to undertake a specialist market analysis as part of planning for provision of infrastructure to the Nelson Mandela Bay Metropolitan Municipality. The primary objective of this study was to identify the growth rates and anticipated number of households per demand zone within the Nelson Mandela Bay Metropolitan Municipality to gain insight on the Metro's infrastructural needs.
- Land Claims Re-opening: Urban-Econ Development Economists was appointed to undertake a Socio-Economic Impact Assessment study as part of the Regulatory Impact Assessment on the feasibility of the reopening of lodgement of claims and provisions to the 19 June cut-off date to accommodate the descendants of the Khoi and San and claims on heritage sites and historical landmarks.
- Suncorp Solar PV EIA: The study presented the socio-economic development (SED) and enterprise development (ED) plans for the proposed Hertzogville Solar Photovoltaic (PV) energy facility. These plans form part of the requirements of the bidding processes for new power generation facilities under the Renewable Energy Independent Power Producer Procurement (IPPP) Programme.
- RBN Mining Procurement Assessment: The objective of the study was to determine the first set of business opportunities that can be established in the Royal Bafokeng area considering the current procurement practices of the selected mines.
- Saldanha REE Separation Plant EIA: Urban-Econ Development Economists was appointed by AGES (Pty) Ltd to undertake an economic impact assessment study for the proposed construction and operation of a Rare Earth Elements (REE) separation plant in Saldanha Bay. This study presented the analysis of economic impacts that are expected to ensue from the proposed project during various stages of the project's life cycle and considering both positive and negative effects.
- Socio-Economic and Economic Impact Assessment Studies conducted as part of the Environmental Impact Assessment Processes
 - Pamish Magnetite Mine EIA - Digby Wells Environmental
 - Helena Solar PV EIA – SiVest Environmental
 - West Rand Tailings Retreatment Project EIA – Digby Wells Environmental
 - Strategic Environmental Assessment for Molemole LM
- WRC Attracting CSRI in Water R&D: Urban-Econ was appointed by the Water Research Commission (WRC) to examine the possibility of forming corporate-WRC partnerships for the roll-out of water and sanitation solutions developed by the WRC into communities.
- A Study of the Economic Impact of load shedding on the City of Johannesburg with or without Kelvin Power Station: A consortium comprising of Ernst and Young and Urban-Econ Development Economists was appointed by City Power to model the potential economic impact on the City with and without Kelvin Power Station in the short term, and the economic impact of outages on the wider economy of the CoJ over the medium term. The specific objectives of the study included demonstrating, quantifying, and interpreting the effect of outages on the City of Johannesburg (CoJ) economy and its growth potential encompassing both of the City Power and Eskom areas of supply, and the effect of the Kelvin Power Station on mitigating the total economic impact of outages on the CoJ.

Countries of Work Experience:

- South Africa

References:

Dr. JL Oberholzer Email: judex@urban-econ.com Cell Phone: +27 (0) 82 770 8770

Elena Broughton Email: elena@urban-econ.com Cell Phone: +27 (0) 82 463 2325

Contact Details:

Memory Madondo Email: memory@urban-econ.com Cell Phone: +27 (0) 73 936 2660

CURRICULUM VITAE

Dr. David Barry Hoare

B.Sc. (Hons), M.Sc., Ph.D., Pr.Nat.Sci. (Ecology, Botany), SAIE&ES (Professional member: Botany, Ecology), IAVS

Contact details

Postnet Suite #116
Private Bag X025, Lynnwood Ridge, 0040
Tel.: (012) 804 2281
Fax: 086 550 2053
Cell: 083 284 5111
E-mail: dhoare@lantic.net / dbhoare@iburst.co.za

Personal information

Date of birth: 04 November 1966, Grahamstown, South Africa
Citizenship: Republic of South Africa
ID no.: 661104 5024 088

Education

Matric - Graeme College, Grahamstown, 1984
B.Sc (majors: Botany, Zoology) - Rhodes University, 1991-1993
B.Sc (Hons) (Botany) - Rhodes University, 1994 with distinction
M.Sc (Botany) - University of Pretoria, 1995-1997 with distinction
PhD (Botany) - Nelson Mandela Metropolitan University, Port Elizabeth

Main areas of specialisation

- Vegetation ecology, primarily in grasslands, thicket, coastal systems, wetlands
- Plant biodiversity and threatened species specialist
- Remote sensing, analysis and mapping of vegetation
- Specialist consultant for environmental management projects

Membership

Professional Natural Scientist, South African Council for Natural Scientific Professions, 16 August 2005 – present. Reg. no. 400221/05 (Ecology, Botany)
Professional member: South African Institute of Ecologists and Environmental Scientists, 10 July 2001 – present. Categories: Botany, Ecology
Member, International Association of Vegetation Scientists

Employment history

1 February 1998 – 30 November 2004, Researcher, Agricultural Research Council, Range and Forage Institute, Private Bag X05, Lynn East, 0039. Duties: project management, general vegetation ecology, remote sensing image processing.
1 December 2004 – present, Member, David Hoare Consulting cc no. 2001/034446/23. Consultant, specialist consultant contracted to a number of existing companies and organisations.
1 January 2009 – 30 June 2009, Lecturer, University of Pretoria, Botany Dept.

Experience as consultant

Ecological consultant since 1995. Author of over 320 specialist ecological consulting reports. Wide experience in ecological studies within grassland, savanna and fynbos, as well as riparian, coastal and wetland vegetation.

Publication record:

Refereed scientific articles (in chronological order):

Journal articles:

HOARE, D.B. & BREDEKAMP, G.J. 1999. Grassland communities of the Amatola / Winterberg mountain region of the Eastern Cape, South Africa. *South African Journal of Botany* 64: 44-61.

- HOARE, D.B.**, VICTOR, J.E., LUBKE, R.A. & MUCINA, L., 2000. Vegetation of the coastal fynbos and rocky headlands south of George, South Africa. *Bothalia* 30: 87-96.
- VICTOR, J.E., **HOARE, D.B.** & LUBKE, R.A., 2000. Checklist of plant species of the coastal fynbos and rocky headlands south of George, South Africa. *Bothalia* 30: 97-101.
- MUCINA, L, BREDEKAMP, G.J., **HOARE, D.B** & MCDONALD, D.J. 2000. A National Vegetation Database for South Africa *South African Journal of Science* 96: 1-2.
- HOARE, D.B.** & BREDEKAMP, G.J. 2001. Syntaxonomy and environmental gradients of the grasslands of the Stormberg / Drakensberg mountain region of the Eastern Cape, South Africa.. *South African Journal of Botany* 67: 595 – 608.
- LUBKE, R.A., **HOARE, D.B.**, VICTOR, J.E. & KETELAAR, R. 2003. The vegetation of the habitat of the Brenton blue butterfly, *Orachrysops niobe* (Trimen), in the Western Cape, South Africa. *South African Journal of Science* 99: 201–206.
- HOARE, D.B** & FROST, P. 2004. Phenological classification of natural vegetation in southern Africa using AVHRR vegetation index data. *Applied Vegetation Science* 7: 19-28.
- FOX, S.C., HOFFMANN, M.T. and HOARE, D. 2005. The phenological pattern of vegetation in Namaqualand, South Africa and its climatic correlates using NOAA-AVHRR NDVI data. *South African Geographic Journal*, 87: 85–94.

Book chapters and conference proceedings:

- HOARE, D.B.** 2002. Biodiversity and performance of grassland ecosystems in communal and commercial farming systems in South Africa. Proceedings of the FAO's Biodiversity and Ecosystem Approach in Agriculture, Forestry and Fisheries Event: 12–13 October, 2002. Food and Agriculture Organisation of the United Nations, Viale delle Terme di Caracalla, Rome, Italy. pp. 10 - 27.
- STEENKAMP, Y., VAN WYK, A.E., VICTOR, J.E., **HOARE, D.B.**, DOLD, A.P., SMITH, G.F. & COWLING, R.M. 2005. Maputaland-Pondoland-Albany Hotspot. In: Mittermeier, R.A., Gil, P.R., Hoffmann, M., Pilgrim, J., Brooks, T., Mittermeier, C.G., Lamoreux, J. & Fonseca, G.A.B. da (eds.) *Hotspots revisited*. CEMEX, pp.218–229. ISBN 968-6397-77-9
- STEENKAMP, Y., VAN WYK, A.E., VICTOR, J.E., **HOARE, D.B.**, DOLD, A.P., SMITH, G.F. & COWLING, R.M. 2005. Maputaland-Pondoland-Albany Hotspot. <http://www.biodiversityhotspots.org/xp/hotspots/maputaland/>.
- HOARE, D.B.**, MUCINA, L., RUTHERFORD, M.C., VLOK, J., EUSTON-BROWN, D., PALMER, A.R., POWRIE, L.W., LECHMERE-OERTEL, R.G., PROCHES, S.M., DOLD, T. and WARD, R.A. *Albany Thickets*. in Mucina, L. and Rutherford, M.C. (eds.) 2006. The vegetation of South Africa, Lesotho and Swaziland. *Strelitzia* 19, South African National Biodiversity Institute, Pretoria.
- MUCINA, L., **HOARE, D.B.**, LÖTTER, M.C., DU PREEZ, P.J., RUTHERFORD, M.C., SCOTT-SHAW, C.R., BREDEKAMP, G.J., POWRIE, L.W., SCOTT, L., CAMP, K.G.T., CILLIERS, S.S., BEZUIDENHOUT, H., MOSTERT, T.H., SIEBERT, S.J., WINTER, P.J.D., BURROWS, J.E., DOBSON, L., WARD, R.A., STALMANS, M., OLIVER, E.G.H., SIEBERT, F., SCHMIDT, E., KOBISI, K., KOSE, L. 2006. *Grassland Biome*. In: Mucina, L. & Rutherford, M.C. (eds.) The vegetation of South Africa, Lesotho and Swaziland. *Strelitzia* 19. South African National Biodiversity Institute, Pretoria.
- RUTHERFORD, M.C., MUCINA, L., LÖTTER, M.C., BREDEKAMP, G.J., SMIT, J.H.L., SCOTT-SHAW, C.R., **HOARE, D.B.**, GOODMAN, P.S., BEZUIDENHOUT, H., SCOTT, L. & ELLIS, F., POWRIE, L.W., SIEBERT, F., MOSTERT, T.H., HENNING, B.J., VENTER, C.E., CAMP, K.G.T., SIEBERT, S.J., MATTHEWS, W.S., BURROWS, J.E., DOBSON, L., VAN ROOYEN, N., SCHMIDT, E., WINTER, P.J.D., DU PREEZ, P.J., WARD, R.A., WILLIAMSON, S. and HURTER, P.J.H. 2006. *Savanna Biome*. In: Mucina, L. & Rutherford, M.C. (eds.) The vegetation of South Africa, Lesotho and Swaziland. *Strelitzia* 19. South African National Biodiversity Institute, Pretoria.
- MUCINA, L., RUTHERFORD, M.C., PALMER, A.R., MILTON, S.J., SCOTT, L., VAN DER MERWE, B., **HOARE, D.B.**, BEZUIDENHOUT, H., VLOK, J.H.J., EUSTON-BROWN, D.I.W., POWRIE, L.W. & DOLD, A.P. 2006. *Nama-Karoo Biome*. In: Mucina, L. & Rutherford, M.C. (eds.) The vegetation of South Africa, Lesotho and Swaziland. *Strelitzia* 19. South African National Biodiversity Institute, Pretoria.
- MUCINA, L., SCOTT-SHAW, C.R., RUTHERFORD, M.C., CAMP, K.G.T., MATTHEWS, W.S., POWRIE, L.W. and **HOARE, D.B.** 2006. *Indian Ocean Coastal Belt*. In: Mucina, L. & Rutherford, M.C. (eds.) The vegetation of South Africa, Lesotho and Swaziland. *Strelitzia* 19. South African National Biodiversity Institute, Pretoria.

Conference Presentations:

- HOARE, D.B. & LUBKE, R.A. *Management effects on diversity at Goukamma Nature Reserve, Southern Cape*; Paper presentation, Fynbos Forum, Bienne Donne, July 1994
- HOARE, D.B., VICTOR, J.E. & LUBKE, R.A. *Description of the coastal fynbos south of George, southern Cape*; Paper presentation, Fynbos Forum, Bienne Donne, July 1994
- HOARE, D.B. & LUBKE, R.A. *Management effects on fynbos diversity at Goukamma Nature Reserve, Southern Cape*; Paper presentation, South African Association of Botanists Annual Congress, Bloemfontein, January 1995
- HOARE, D.B. & BOTHA, C.E.J. *Anatomy and ecophysiology of the dunegrass Ehrharta villosa var. maxima*; Poster presentation, South African Association of Botanists Annual Congress, Bloemfontein, January 1995
- HOARE, D.B., PALMER, A.R. & BREDENKAMP, G.J. 1996. *Modelling grassland community distributions in the Eastern Cape using annual rainfall and elevation*; Poster presentation, South African Association of Botanists Annual Congress, Stellenbosch, January 1996
- HOARE, D.B. *Modelling vegetation on a past climate as a test for palaeontological hypotheses on vegetation distributions*; Paper presentation, Randse Afrikaanse Universiteit postgraduate symposium, 1997
- HOARE, D.B., VICTOR, J.E. & BREDENKAMP, G.J. *Historical and ecological links between grassy fynbos and afro-montane fynbos in the Eastern Cape*; Paper presentation, South African Association of Botanists Annual Congress, Cape Town, January 1998
- LUBKE, R.A., HOARE, D.B., VICTOR, J.E. & KETELAAR, R. *The habitat of the Brenton Blue Butterfly*. Paper presentation, South African Association of Botanists Annual Congress, Cape Town, January 1998
- HOARE, D.B. & PANAGOS, M.D. *Satellite stratification of vegetation – structure or floristic composition?* Poster presentation at the 34th Annual Congress of the Grassland Society of South Africa, Warmbaths, 1-4 February 1999.
- HOARE, D.B. & WESSELS, K. *Conservation status and threats to grasslands of the northern regions of South Africa*, Poster presentation at the South African Association of Botanists Annual Congress, Potchefstroom, January 2000.
- HOARE, D.B. *Phenological dynamics of Eastern Cape vegetation*. Oral paper presentation at the South African Association of Botanists Annual Congress, Grahamstown, January 2002.
- HOARE, D.B., MUCINA, L., VAN DER MERWE, J.P.H. & PALMER, A.R. *Classification and digital mapping of grasslands of the Eastern Cape* Poster presentation at the South African Association of Botanists Annual Congress, Grahamstown, January 2002.
- HOARE, D.B. *Deriving phenological variables for Eastern Cape vegetation using satellite data* Poster presentation at the South African Association of Botanists Annual Congress, Grahamstown, January 2002.
- MUCINA, L., RUTHERFORD, M.C., HOARE, D.B. & POWRIE, L.W. 2003. *VegMap: The new vegetation map of South Africa, Lesotho and Swaziland*. In: Pedrotti, F. (ed.) *Abstracts: Water Resources and Vegetation, 46th Symposium of the International Association for Vegetation Science*, June 8 to 14 – Napoli, Italy.
- HOARE, D.B. 2003. *Species diversity patterns in moist temperate grasslands of South Africa*. Proceedings of the VIIth International Rangeland Congress, 26 July – 1 August 2003, Durban South Africa. *African Journal of Range and Forage Science*. 20: 84.

Unpublished technical reports:

- PALMER, A.R., HOARE, D.B. & HINTSA, M.D., 1999. *Using satellite imagery to map veld condition in Mpumalanga: A preliminary report*. Report to the National Department of Agriculture (Directorate Resource Conservation). ARC Range and Forage Institute, Grahamstown.
- HOARE, D.B. 1999. *The classification and mapping of the savanna biome of South Africa: methodology for mapping the vegetation communities of the South African savanna at a scale of 1:250 000*. Report to the National Department of Agriculture (Directorate Resource Conservation). ARC Range and Forage Institute, Pretoria.
- HOARE, D.B. 1999. *The classification and mapping of the savanna biome of South Africa: size and coverage of field data that exists on the database of vegetation data for South African savanna*. Report to the National Department of Agriculture (Directorate Resource Conservation). ARC Range and Forage Institute, Pretoria.
- THOMPSON, M.W., VAN DEN BERG, H.M., NEWBY, T.S. & HOARE, D.B. 2001. *Guideline procedures for national land-cover mapping and change monitoring*. Report no. ENV/P/C 2001-006 produced for Department of Water Affairs and Forestry, National Department of Agriculture and

- Department of Environment Affairs and Tourism. Copyright: Council for Scientific and Industrial Research (CSIR) and Agricultural Research Council (ARC).
- HOARE, D.B. 2003. Natural resource survey of node O R Tambo, using remote sensing techniques, Unpublished report and database of field data for ARC Institute for Soil, Climate & Water, ARC Range and Forage Institute, Grahamstown.
- HOARE, D.B. 2003. Short-term changes in vegetation of Suikerbosrand Nature Reserve, South Africa, on the basis of resampled vegetation sites. Gauteng Department of Agriculture, Conservation, Environment and Land Affairs, Conservation Division.
- BRITTON, D., SILBERBAUER, L., ROBERTSON, H., LUBKE, R., HOARE, D., VICTOR, J., EDGE, D. & BALL, J. 1997. The Life-history, ecology and conservation of the Brenton Blue Butterfly (*Orachrysops niobe*) (Trimen)(*Lycaenidea*) at Brenton-on-Sea. Unpublished report for the Endangered Wildlife Trust of Southern Africa, Johannesburg. 38pp.
- HOARE, D.B., VICTOR, J.E. & MARNEWIC, G. 2005. Vegetation and flora of the wetlands of Nylsvley River catchment as component of a project to develop a framework for the sustainable management of wetlands in Limpopo Province.

Consulting reports:

Total of over 320 specialist consulting reports for various environmental projects from 1995 – 2010.

Workshops / symposia attended:

- Workshop on remote sensing of rangelands presented by Paul Tueller, University of Nevada Reno, USA, VIIth International Rangeland Congress, 26 July – 1 August 2003, Durban South Africa.
- VIIth International Rangeland Congress, 26 July – 1 August 2003, Durban South Africa.
- BioMap workshop, Stellenbosch, March 2002 to develop strategies for studying vegetation dynamics of Namaqualand using remote sensing techniques
- South African Association of Botanists Annual Congress, Grahamstown, January 2002.
- 28th International Symposium on Remote Sensing of Environment, Somerset West, 27-31 March 2000.
- Workshop on Vegetation Structural Characterisation: Tree Cover, Height and Biomass, 28th International Symposium on Remote Sensing of Environment, Strand, 26 March 2000.
- South African Association of Botanists Annual Congress, Potchefstroom, January 2000
- National Botanical Institute Vegmap Workshop, Kirstenbosch, Cape Town, 30 September-1 October 1999.
- Sustainable Land Management – Guidelines for Impact Monitoring, Orientation Workshop: Sharing Impact Monitoring Experience, Zithabiseni, 27-29 September 1999.
- WWF Macro Economic Reforms and Sustainable Development in Southern Africa, Environmental Economic Training Workshop, development Bank, Midrand, 13-14 September 1999.
- 34th Annual Congress of the Grassland Society of South Africa, Warmbaths, 1-4 February 1999
- Expert Workshop on National Indicators of Environmental Sustainable Development, Dept. of Environmental Affairs and Tourism, Roodevallei Country Lodge, Roodeplaat Dam, Pretoria, 20-21 October 1998.
- South African Association of Botanists Annual Congress, Cape Town, January 1998
- Randse Afrikaanse Universiteit postgraduate symposium, 1997.
- South African Association of Botanists Annual Congress, Bloemfontein, January 1995.

Referees:

- Michele Pfab, Scientific Co-ordinator: Scientific Authority, Applied Biodiversity Research, South African National Biodiversity Institute, (012) 843 5025, **E-mail:** M.Pfab@sanbi.org.za
- Prof. Roy Lubke, Botany Department, Rhodes University, Grahamstown 6140 Tel: 0461-318 592. E-mail: r.lubke@ru.ac.za
- Prof. Richard Cowling, Botany Department, Nelson Mandela Metropolitan University, Tel (042) 298 0259 E-mail: rmc@kingsley.co.za

CURRICULUM VITAE

Andrea Gibb

Name Andrea Gibb

Profession Environmental Practitioner

Name of Firm SiVEST SA (Pty) Ltd

Present Appointment Environmental Practitioner and Visual Specialist:
Environmental Division

Years with Firm 6 Years

Date of Birth 29 January 1985

ID Number 8501290020089

Nationality South African

**Education**

Matriculated 2003, Full Academic Colours, Northcliff High School, Johannesburg, South Africa

Professional Qualifications**BSc (Hons) Environmental Management** (University of South Africa 2008-2010)

Coursework: Project Management, Environmental Risk Assessment and Management, Ecological and Social Impact Assessment, Fundamentals of Environmental Science, Impact Mitigation and Management, Integrated Environmental Management Systems & Auditing, Integrated Environmental Management, Research Methodology.

Research Proposal: Golf Courses and the Environment

BSc Landscape Architecture (with distinction) (University of Pretoria 2004-2007)

Coursework: Core modules focused on; design, construction, environmental science, applied sustainability, shifts in world paradigms and ideologies, soil and plant science, environmental history, business law and project management.

Awards: Cave Klapwijk prize for highest average in all modules in the Landscape Architecture programme, ILASA book prize for the best Landscape Architecture student in third year design, Johan Barnard planting design prize for the highest distinction average in any module of plant science.

ArcGIS Desktop 1 (ESRI South Africa December 2010)**Environmental Impact Assessment (EIA) 2014 Legal Regime Workshop** (Imbewu 2015)**Employment Record**

Aug 2010 – to date SiVEST SA (Pty) Ltd: Environmental Practitioner
Jan 2008 – July 2010 Cave Klapwijk and Associates: Environmental Assistant and Landscape Architectural Technologist
Feb 2006 – Dec 2006 Cave Klapwijk and Associates: Part time student

Language Proficiency

LANGUAGE	SPEAK	READ	WRITE
English	Fluent	Fluent	Fluent

Key Experience

Specialising in the field of Environmental Management and Visual Assessment.

Andrea joined SiVEST in August 2010 and holds the position of Environmental Practitioner in the Johannesburg Office. She has 8.5 years' work experience and specialises in managing large scale multifaceted EIAs and Basic Assessment (BAs), primarily related to renewable energy generation and electrical distribution. She also specialises in undertaking visual impact and landscape assessments. She has extensive experience in overseeing public participation and stakeholder engagement processes and has been involved in environmental baseline assessments, fatal flaw / feasibility assessments and environmental negative mapping / sensitivity analyses. From a business and administrative side, Andrea is actively involved in maintaining good client relationships, mentoring junior staff and maintaining the financial performance of the projects she leads.

Skills include:

- Project Management (MS Project)
- Environmental Impact Assessment (EIA)
- Basic Assessment (BA)
- Public Participation Management
- Visual Impact Assessment (VIA)
- Landscape Assessment
- Strategic Environmental Planning
- Documentation / Quality Control
- Project Level Financial Management

Projects Experience

Aug 2010 – to date

ENVIRONMENTAL IMPACT ASSESSMENT (EIA) / BASIC ASSESSMENT (BA)

- EIA for the proposed development of the Tlisitseng 1 and 2 75MW Solar Photovoltaic (PV) Energy Facilities near Lichtenburg, North West Province.
- EIAs for the proposed development of the Sendawo 1, 2, and 3 75MW Solar PV Energy Facilities near Vryburg, North West Province.
- EIA for the proposed construction of the Sendawo Common Collector Substation and power line near Vryburg, North West Province.
- EIA for the proposed construction of the Aletta 140MW Wind Energy Facility near Copperton, Northern Cape Province.
- Application for an Amendment of the Environmental Authorisation (EA) for the proposed construction of the 100MW Limestone Solar Thermal Power Project near Danielskuil, Northern Cape Province.
- Applications for the Amendment of the EAs for the proposed construction of three 75MW solar PV facilities near Prieska, Northern Cape Province.
- Applications for the Amendment of the EAs for the proposed construction of the 75MW Arriesfontein and Wilger Solar Power Plants near Danielskuil, Northern Cape Province.
- Completion and submission of the final EIA report for the proposed Rooipunt PV Solar Power Park Phase 1 and proposed Rooipunt PV Solar Power Park Phase 2 near Upington, Northern Cape Province.
- EIAs for the proposed construction of the Helena 1, 2 and 3 75MW Solar PV Energy Facilities near Copperton, Northern Cape Province.
- EIA for the proposed construction of the Nokukhanya 75MW Solar PV Power Plant near Dennilton, Limpopo Province.
- EIA for the proposed development of the Dwarsrug Wind Farm near Loeriesfontein, Northern Cape Province.

- BA for the proposed construction of two 132kV power lines and associated infrastructure from the Redstone Solar Thermal Power Project site to the Olien MTS near Lime Acres, Northern Cape Province.
- BA for the proposed construction of two 132kV power lines and associated infrastructure from Silverstreams DS to the Olien MTS near Lime Acres, Northern Cape Province.
- BA for the proposed Construction of the SSS1 5MW Solar PV Plant on the Western Part of Portion 6 (Portion of Portion 5) of Farm Spes Bona 2355 near Bloemfontein, Free State Province.
- BA for the proposed Construction of the SSS2 5MW Solar PV Plant on the Eastern Part of Portion 6 (Portion of Portion 5) of Farm Spes Bona 2355 near Bloemfontein, Free State Province.
- BA for the proposed Mookodi Integration Phase 2: Proposed Construction of a 132kV power line from the proposed Bophirima Substation to the existing Schweizer-Reneke Substation, North West Province.
- BA for the proposed Mookodi Integration Phase 2: Proposed Construction of a 132kV power line from the Mookodi Substation to the existing Magopela Substation, North West Province.
- BA for the proposed Mookodi Integration Phase 2: Proposed Construction of the Mookodi - Ganyesa 132kV power line, proposed Ganyesa Substation and Havelock LILO, North West Province.
- Amendment of the Final Environmental Impact Report for the Proposed Mookodi 1 Integration Project near Vryburg, North West Province.
- BA for the proposed 132kV power line and associated infrastructure for the proposed Redstone Solar Thermal Energy Plant near Lime Acres, Northern Cape Province.
- BA for the proposed construction of a 132kV power line and substation associated with the 75MW PV Plant on the Farm Droogfontein (PV 3) in Kimberley, Northern Cape Province.
- BA for the proposed establishment of a Learning and Development Retreat and an Executive Staff and Client Lodge at Mogale's Gate, Gauteng Province.
- Application for an Amendment of the EA to increase the output of the proposed 40MW PV Facility on the farm Mierdam to 75MW, Northern Cape Province.
- BA for the proposed construction of a power line and substation near Postmasburg, Northern Cape Province.
- BA for the proposed West Rand Strengthening Project – 400kV double circuit power line and substation extension in the West Rand, Gauteng.
- EIA for the proposed construction of a wind farm and PV plant near Prieska, Northern Cape Province.
- Public Participation assistance as part of the EIA for the proposed Thyspunt Transmission Lines Integration Project – EIA for the proposed construction of 5 x 400kV transmission power lines between Thyspunt to Port Elizabeth, Eastern Cape Province.
- EIA assistance for the proposed construction of three Solar Power Plants in the Northern Cape Province.
- Public Participation as part of the EIA for the proposed Delareyville Kopela Power Line and Substation, North West Province.
- Public Participation as part of the EIA for the Middelburg Water Reclamation Project, Mpumalanga Province.

VISUAL IMPACT ASSESSMENT (VIA)

- VIA (Scoping Phase) for the proposed construction of a 3000MW Wind Farm and associated infrastructure near Richmond, Northern Cape Province.
- VIA for the proposed construction of a power line and associated infrastructure for the proposed Kalkaar Solar Thermal Power Plant near Kimberley, Free State and Northern Cape Provinces.
- VIA for the proposed construction of a power line and associated infrastructure for the proposed Rooipunt Solar Thermal Power Plant near Upington, Northern Cape Province.
- VIAs (Impact Phase) for the proposed construction of the Sendawo 1, 2 and 3 solar PV energy facilities near Vryburg, North West Province.

-
- VIA (Impact Phase) for the proposed construction of the Sendawo substation and associated power line near Vryburg, North West Province.
 - VIAs (Impact Phase) for the proposed construction of the Tlisitseng 1 and 2 solar PV energy facilities near Lichtenburg, North West Province.
 - VIA for the proposed construction of the Tlisitseng substation and associated 132kV power line near Lichtenburg, North West Province.
 - VIA (Scoping Phase) for the proposed construction of the Sendawo substation and associated power line near Vryburg, North West Province.
 - VIA (Scoping Phase) for the proposed construction of the Sendawo 1, 2 and 3 solar PV energy facilities near Vryburg, North West Province.
 - VIA (Scoping Phase) for the proposed construction of the Tlisitseng 1 and 2 solar PV energy facilities near Lichtenburg, North West Province.
 - Visual recommendations for Phase 1 of the proposed Renishaw Estate Mixed Use Development, KwaZulu-Natal Province.
 - VIA for the proposed Tinley Manor South Banks Development, KwaZulu-Natal Province.
 - VIAs (Impact Phase) for the proposed construction of the Helena 1, 2 and 3 75MW Solar PV Energy Facilities near Copperton, Northern Cape Province.
 - VIA (Scoping Phase) for the proposed construction of the Helena 1, 2 and 3 75MW Solar PV Energy Facilities near Copperton, Northern Cape Province.
 - Visual Due Diligence Report for the possible rapid rail extensions to the Gauteng network, Gauteng Province.
 - Visual Status Quo and Constraints Report for the possible rapid rail extensions to the Gauteng network, Gauteng Province.
 - VIA for the proposed agricultural components of the Integrated Sugar Project in Nsoko, Swaziland.
 - VIA for the proposed Tweespruit to Welroux power lines and substation, Free State Province.
 - VIA for the proposed construction of the Nokukhanya 75MW Solar PV Power Plant near Dennilton, Limpopo Province.
 - VIA (Impact Phase) for the proposed development of the Dwarsrug Wind Farm near Loeriesfontein, Northern Cape Province.
 - VIA for the proposed amendment to the authorised power line route from Hera Substation to Westgate Substation, Gauteng Province.
 - VIA (Impact Phase) for the Eastside Junction Mixed Use Development near Delmas, Mpumalanga Province.
 - VIA for the proposed construction of two 132kV power lines and associated infrastructure from the Redstone Solar Thermal Power Project site to the Olien MTS near Lime Acres, Northern Cape Province.
 - VIA for the proposed construction of two 132kV power lines and associated infrastructure from Silverstreams DS to the Olien MTS near Lime Acres, Northern Cape Province.
 - VIA (Scoping Phase) for the proposed development of the Dwarsrug Wind Farm near Loeriesfontein, Northern Cape Province.
 - VIA for the proposed Rorqual Estate Development near Park Rynie on the South Coast of KwaZulu Natal.
 - VIA (Scoping Phase) for the proposed construction of a Coal-fired Power Station, Coal Mine and Associated Infrastructure near Colenso, KwaZulu-Natal Province.
 - VIA for the proposed Mookodi Integration Phase 2: Proposed Construction of the Mookodi - Ganyesa 132kV power line, proposed Ganyesa Substation and Havelock LILO, North West Province.
 - VIA for the proposed construction of the Duma transmission substation and associated Eskom power lines, KwaZulu-Natal Province.
 - VIA for the proposed construction of the Madlanzini transmission substation and associated Eskom power lines, Mpumalanga Province.
 - VIA for the proposed rebuild of the 88kV power line from Normandie substation to Hlungwane substation, Mpumalanga and KwaZulu-Natal Provinces.
 - VIA for the proposed construction of the Nzalo transmission substation and associated Eskom power lines, KwaZulu-Natal Province.

- VIA for the proposed construction of the Sheepmoor traction substation with two 20MVA transformer bays and a new associated 88kV turn-in power line, Mpumalanga Province.
- VIA for the proposed rebuild of the 88kV power line from Uitkoms substation to Antra T-off, Mpumalanga Province.
- VIA for the proposed rebuild of the 88kV power line from Umfolozi substation to Eqwasha traction substation including an 88kV turn-in power line to Dabula traction substation, Kwazulu-Natal Province.
- VIA for the proposed construction of the new 88/25kV Vryheid traction substation with two 20MVA transformer bays and a new associated 88kV turn-in power line, KwaZulu-Natal Province.
- VIA for the proposed construction of a 132kV power line and substation associated with the 75MW PV Plant on the Farm Droogfontein (PV 3) in Kimberley, Northern Cape Province.
- VIA (Impact Phase) for the proposed Construction of a Solar PV Power Plant near De Aar, Northern Cape Province.
- VIA for the (Impact Phase) proposed Construction of the Renosterberg Wind Farm near De Aar, Northern Cape Province.
- VIA for the (Impact Phase) proposed Construction of the Renosterberg Solar PV Power Plant near De Aar, Northern Cape Province.
- VIA for the proposed construction of a 132kV power line for the Redstone Thermal Energy Plant near Lime Acres, Northern Cape Province.
- VIA for the proposed Mookodi Integration phase 2 132kV power lines and Ganyesa substation near Vryburg, North West Province.
- VIA for the proposed 132kV power lines associated with the PV Plants on Droogfontein Farm near Kimberley, Northern Cape Province.
- VIA (Scoping phase) for the Eastside Junction Mixed Use Development near Delmas, Mpumalanga Province.
- VIA for the proposed development of a learning and development retreat and an executive and staff lodge at Mogale's Gate, Gauteng Province.
- VIA for the proposed construction of a substation and 88kV power line between Heilbron (via Frankfort) and Villiers, Free State Province.
- Visual Status Quo Assessment for the Moloto Development Corridor Feasibility Study in the Gauteng Province, Limpopo Province and Mpumalanga Province.
- VIA the West Rand Strengthening Project – 400kV double circuit power line and substation extension in the West Rand, Gauteng.
- VIA for the proposed construction of a wind farm and solar photovoltaic plant near Loeriesfontein, Northern Cape Province.
- Visual sensitivity mapping exercise for the proposed Mogale's Gate Expansion, Gauteng.
- VIA (Scoping Phase) for the proposed Renosterberg Solar PV Power Plant and Wind Farm near De Aar, Northern Cape Province.
- Scoping level VIAs for the proposed construction of three Solar Power Plants in the Northern Cape Province.
- VIAs for the Spoornet Coalink Powerline Projects in KZN and Mpumalanga.
- Visual Constraints Analysis for the proposed establishment of four Wind Farms in the Eastern and Northern Cape Province.
- VIA (Scoping Phase) for the proposed development of a solar energy facility in De Aar, Northern Cape.
- VIA (Scoping Phase) for the proposed development of a solar energy facility in Kimberley, Northern Cape.

STRATEGIC ENVIRONMENTAL PLANNING

- Assistance with the Draft Environmental Management Framework for the Mogale City Local Municipality, Gauteng Province.
- Sensitivity Negative Mapping Analysis for the proposed Mogale's Gate Development, Gauteng Province.

OTHER**Jan 2008 – July 2010**

Environmental management, research, report writing, and landscape design for several development projects:

- Report writing, coordination and public participation for several BAs.
- Planting design (including rehabilitation) in accordance with natural ecological processes, endemic species and appropriate techniques.
- Graphic presentations and mapping for several VIAs and landscape architectural designs, including three-dimensional imagery.

Feb 2006 – Dec 2006

Landscape Architectural drafting, rendering and planting design for a variety of projects including the Oprah Winfrey Academy for girls and the New UNISA Student Entrance Building.

Wouter Fourie
Professional Heritage Specialist and Director PGS Heritage

Summary of Experience

Specialised expertise in Cultural Resource Management and Heritage Impact Assessment Management, Archaeology, Anthropology, Applicable survey methods, Fieldwork and project management, Geographic Information Systems, including *inter alia*:

Involvement with various Heritage Impact Assessments, within South Africa, including:

- Archaeological Walkdowns for various projects
- Phase 2 Heritage Impact Assessments and EMPs for various projects
- Heritage Impact Assessments for various projects

Iron Age Mitigation Work for various projects, including archaeological excavations and monitoring

Involvement with various Heritage Impact Assessments, outside South Africa, including:

- Heritage Impact Assessments in Democratic Republic of Congo
- Heritage Impact Assessments in Mozambique, Botswana and DRC
- Grave Relocation projects in DRC

Involvement in various grave relocation projects (some of which relocated up to 1000 graves) and grave "rescue" excavations in the various provinces of South Africa

Key Qualifications

BA [Hons] (Cum laude): Archaeology and Geography

BA: Archaeology, Geography and Anthropology

Professional Archaeologist - Association of Southern African Professional Archaeologists (ASAPA) - Professional Member

Accredited Professional Heritage Specialist – Association of Professional Heritage Practitioners (APHP)

CRM Accreditation (ASAPA):

- Principal Investigator - Grave Relocations
- Field Director – Iron Age
- Field Supervisor – Colonial Period and Stone Age

Accredited with Amafa KZN and Eastern Cape PHRA

Key Work Experience

2008- current: Director –Professional Grave Solutions (Pty) Ltd t/a PGS Heritage

2007 – 2008: Project Manager – Matakoma-ARM, Heritage Contracts Unit, University of the Witwatersrand

2005-2007: Director - Professional Grave Solutions (Pty) Ltd

2000-2004: CEO– Matakoma Consultants

1998-2000: Environmental Coordinator – Randfontein Estates Limited. Randfontein, Gauteng

1997-1998: Environmental Officer – Department of Minerals and Energy. Johannesburg, Gauteng

CURRICULUM VITAE

MARTIN FERREIRA

NAME OF PERSON : *MARTIN FERREIRA*

NATIONALITY : *SOUTH AFRICAN*

DATE OF BIRTH : *1982/02/19*

NAME OF CURRENT FIRM : *JEFFARES & GREEN (PTY) LTD*

PROFESSION : *AQUATIC SCIENTIST*

POSITION IN FIRM : *SENIOR AQUATIC SCIENTIST*

QUALIFICATION : *PhD. Aquatic health*

SPECIALISATION IN FIRM : *AQUATIC SCIENCE*

YEARS OF EXPERIENCE : *7*

YEARS WITH CURRENT FIRM : *3.3*

SUMMARY OF EXPERIENCE

Martin completed his PHD in aquatic health under the supervision of Prof Victor Wepener at the beginning of 2010. His research focused on the development of methods to determine the ecological integrity of endorheic wetlands. Since January 2008 he has worked as co-manager at Econ@uj. Econ@uj is a multi-disciplinary consortium of environmental specialists based at the University of Johannesburg (UJ). He has completed numerous specialist studies for Environmental Impact Assessments throughout Southern Africa. These studies were conducted for various land use activities (especially mining). These studies were conducted on riverine, estuarine and wetland ecosystems. Martin's duties included the writing of project proposals, calculating project costs and formulating budgets, organisation of field surveys, completion of field surveys, writing of project reports and management of human resources.

Martin joined Jeffares and Green in the beginning of 2012 as an Aquatic Scientist, providing specialist services related to water quality monitoring, biomonitoring, ecological state assessments of rivers and wetlands, wetland delineations, Water Use Authorisation, Environmental Impact Assessments, Environmental Audits and Environmental Control Officer duties. He is also actively involved in research and serves as a steering committee member for several Water Research Commission (WRC) funded projects and is also a project leader for projects funded by the WRC.

He has working experience of the various Ecostatus modules that form part of the reserve (including MIRAI and FRAI) and also has extensive knowledge and experience in aquatic resource monitoring through the use of the River Health Program methodologies (South African Scoring System version 5 accredited since 2005). Through presentations at national and international conferences and the writing of numerous reports and publications he has required excellent verbal and written communication skills. He also has excellent computer skills including GIS software (ArcGIS) and several statistical software packages (Primer, Canoco, SPSS).

EDUCATION

- 2000 : **Matric** – Gekombineerde Skool Noorderlig.
2003 : **BSc** (Aquatic Health) -Rand Afrikaans University
2004 : **BSc Hons** (Aquatic Health) - Rand Afrikaans University
2006 : **MSc** (Aquatic Health) *Cum Laude* - University of Johannesburg
2010 : **PhD** (Aquatic Health) - University of Johannesburg

SPECIFIC EXPERIENCE

Jeffares & Green (Pty) Ltd

- 2015 – Present** : Position: Senior Aquatic Scientist
Assessment and monitoring of rivers and wetlands associated with the construction of the Kusile Power Station near Ogies, Mpumalanga
Biomonitoring services and water quality monitoring for 19 Wastewater Care Works for the Eastrand Water Care Company
Assessment and delineation of wetland associated with the Ford South Africa operational facility
Annual water quality audit for the Kumba Iron Ore mining operations
Assessment and delineation of wetlands associated with the decommissioning of the Atlas Substation near Meyerton, Gauteng
Assessment of the impacts of land use changes on the water quality of selected RAMSAR wetlands
- 2014 – 2015** : Position: Senior Aquatic Scientist
Assesment of rivers, wetlands and drainage lines associated with the Kumba Iron Ore mining activities for the application of a section 21 (c) and (i) WULA
Assessment and delineation of wetland associated with a landfill facility near Springs, Gauteng
Assessment and delineation of wetland associated with the BECSA mining activities, Mpumalanga
Assessment and delineation of wetlands associated with a new housing development in the Sol Plaatjies Municipality, Kimberley
Assessment and delineation of wetland associated with the construction of a bulk sewer near Meyerton
Biomonitoring services for Kumba Iron Ore, Thabazimbi
Assessment and monitoring of rivers and wetlands associated with the construction of the Kusile Power Station near Ogies, Mpumalanga
Assessment and delineation of wetlands associated with the upgrade of the Thabong interchange near Welkom, Free State
Biomonitoring services and water quality monitoring for 19 Wastewater Care Works for the Eastrand Water Care Company
Biomonitoring of selected sites associated with the Mafube Colliery near Middelburg, Mpumalanga
- 2013 – 2014** : Position: Aquatic Scientist
: Biomonitoring services for Kumba Iron Ore, Thabazimbi

- : Assessment of the fish communities of the lower Nsuzi and Thukela rivers for the establishment of an irrigation scheme, Kwazulu-Natal
- : Delineation of wetlands associated with the construction of a substation and associated infrastructure near Harrismith, KwaZulu-Natal
- : Assessment and delineation of wetlands associated with the upgrade of the R545 and D686 near Emalahleni
- : Biomonitoring services and water quality monitoring for 19 Wastewater Care Works for the Eastrand Water Care Company
- : Wetland Specialist Assessment for the Ermelo Majuba Railway line, Ermelo Mpumalanga.
- : Biomonitoring services and water quality monitoring for the Ermelo Majuba Railway line, Ermelo Mpumalanga
- : Aquatic invertebrate and habitat state assessment for various rivers associated with mining activities in Thabazimbi
- : Aquatic specialist services for the assessment of the impact of proposed upgrade Eskom's electricity network associated with 14 riverine systems in Pretoria
- : Identification and delineation of wetlands associated with the upgrade of the Johannesburg Fresh Produce Market
- : Environmental Control Officer for the upgrade of the N11 near Newcastle, South Africa
- : Independent environmental auditor of selected landfill sites and operations for Scaw Metals
- : Project leader for a Water Research Commission funded study on the applicability of a trophic based classification system for endorheic wetlands and the effect of Acid Mine Drainage on the hatching success of selected invertebrates

2012 – 2013

- : Position: Aquatic Scientist
- : Aquatic specialist studies for selected ecosystems associated with coal mining and power generation activities near Middelburg, Mpumalanga.
- : Project leader for a Water Research Commission funded study on the applicability of a trophic based classification system for endorheic wetlands and the effect of Acid Mine Drainage on the hatching success of selected invertebrates
- : Aquatic invertebrate assessment for the systematic water quality monitoring of the Okavango Delta, Botswana
- : Biomonitoring and water quality monitoring of Waste Water Treatment Works in the Tshwane metropolitan, South Africa
- : Aquatic specialist studies for selected riverine and wetland sites near Middelburg (South Africa) as part of an EIA for coal mining activities
- : Assisted with the biomonitoring and water quality monitoring of Waste Water Treatment Works for the City of Johannesburg, South Africa
- : Aquatic macroinvertebrate and habitat assessment of selected sites associated with mining activities in Thabazimbi, South Africa
- : Environmental Control Officer for the upgrade of the N11 near Newcastle, South Africa
- : Independent environmental auditor of selected landfill sites within the Johannesburg Metropolitan
- : Aquatic specialist studies for the Water Use Authorisation for the upgrade of a pedestrian bridge at Henley-on-Klip, South Africa
- : Aquatic specialist studies to determine the impact of emergency repair work of a railway line at Kamfers Dam in Kimberley (South Africa)

- : Aquatic specialist studies for the Water Use Authorisation for the emergency repairs of the parking area for Makro, Centurion, South Africa
- : Biomonitoring of selected rivers within the Sasolburg industrial area, South Africa
- : Aquatic specialist studies for the Water Use Authorisation for endorheic wetlands near Kriel, Mpumalanga

Econ@uj

- 2007 – 2011**
- : Assessment of the ecological state of the local aquatic ecosystem associated with a coal siding, Mpumalanga, South Africa
 - : Assessment of the ecological state of the lower Mvoti and Tugela River and Estuarine systems, KZN, South Africa
 - : Assisted with biomonitoring of Tshwane waste water treatment works, Pretoria, South Africa
 - : Assessment of the ecological state of the local aquatic ecosystem associated with Anglo coal mining activities, Mpumalanga, South Africa
 - : Assessment of the availability of fish communities as part of a human health risk assessment in KZN, South Africa
 - : Aquatic specialist studies for the EIA for the proposed upgrade of the N1 highway, Johannesburg, South Africa
 - : Aquatic specialist studies for the EIA for the proposed sand mining activities in the Eastern Cape, South Africa
 - : Aquatic specialist studies for the EIA for the proposed coal mining activities near Newcastle, South Africa
 - : Aquatic specialist studies for the EIA for a coal washing plant and siding near Newcastle, South Africa.
 - : Assisted in aquatic specialist studies for the EMP for a platinum mine in Polokwane, South Africa.
 - : Biomonitoring of aquatic ecosystem associated with the construction of a railway line near Ermelo, South Africa.
 - : Assessment of the ecological integrity of the Klip River, South Africa for the establishment of a water quality management program
 - : Assessment of the aquatic ecosystems associated with mining activities in Thabazimbi
 - : Aquatic specialist studies for the EIA for the proposed coal mining activities in Mpumalanga, South Africa
 - : Fish community assessment of the Dwars River near Polokwane
 - : Assessment of the aquatic invertebrate communities associated with the Olifants River Water Resources Development Project Phase 2 (ORWRDP-2).

University of Johannesburg

- 2011-present : Supervision of Masters and honours students
- 2007 - 2011 : Lecturer for 3rd year freshwater ecology courses
- 2010 : Lecturer in human physiology third year courses
- 2008 - 2010 : Supervision of honours students (projects)
- 2008 - 2010 : Part time lecturer in Indices of Biotic Integrity for honours courses
- 2004 -2008 : 3rd year practical demonstrator in ecology and animal physiology

PUBLISHED PAPERS

M Ferreira, V Wepener & JHJ Van Vuuren (2008). The effect of paper mill activities on the fish community structure of the Elands river, Mpumalanga. *Suid-Afrikaanse Tydskrif vir Natuurwetenskap en Tegnologie*, Vol. 27 (4) pp 82–94.

M Ferreira, V Wepener & JHJ Van Vuuren (2009). Spatial and temporal variation in the macroinvertebrate community structure of the lower Elands River, Mpumalanga, South Africa. *African Journal of Aquatic Science* 2009 Vol.34 (3) pp 231–238.

M Ferreira, V Wepener & JHJ Van Vuuren (2010). The occurrence of large Branchiopod crustaceans in perennial pans: a research note. *African Journal of Zoology*. Vol. 46 (1) pp 176-178

M Ferreira, V Wepener & JHJ Van Vuuren (2012). Aquatic invertebrate communities of perennial pans in Mpumalanga, South Africa: a diversity and functional approach. *African Invertebrates*. Vol. 53 (2) pp 751–768

AJ Henri, V Wepener, M Ferreira, W Malherbe & JHJ Van Vuuren (2014). The effect of acid mine drainage on the hatching success of branchiopod egg banks from endorheic wetlands in South Africa. *Hydrobiologia*. Volume 738 (1) pp 35-48

Liefferink SL, Tate RB, JHJ van Vuren JHJ, Ferreira M & W Malherbe W (2014). A comparison of methods for incubating zooplankton diapausing eggs from sediment of endorheic pans in the Free State, South Africa. *African Journal of Aquatic Science*. pp1–7

Professional membership

SASAqS Southern African Society of Aquatic Scientists
SETAC Society of Environmental Toxicology and Chemistry
SACNASP Registered with the South African Council for Natural Scientific Professions.
Registration number 400265/11 (Ecological Sciences)

Computer and software skills

GIS : Arc, QGIS, MapWindow
Statistical : Primer, Canoco, SPSS
Other : Microsoft Office

LANGUAGES

English : Very Good
Afrikaans : Excellent

Name	Veronique Mary Evans
Profession	Environmentalist
Name of Firm	SiVEST SA (Pty) Ltd
Present Appointment	Graduate Environmental Consultant
Years with Firm	Joined August 2012
Date of Birth	9 November 1990
ID Number	9011091040087
Nationality	South African



Education

St Peters College, Sunninghill, Johannesburg, South Africa Matriculated 2008

Professional Qualifications

MSc - Environmental Science in Conservation and Ecology, University of the Witwatersrand (Current)
 BSc (Hons) - Environmental Science in Conservation and Ecology, University of the Witwatersrand,
 (Completion date: November 2013).

Research Proposal: Selective herbivore use of post-fire grass ash in a Highveld grassland.

BSc - Environmental Conservation and Ecology, Zoology and Geography, University of the
 Witwatersrand, (Completion date: November 2012)

Academic Awards

National Research Foundation Honours: Innovation Scholarship - 2013

Employment Record

Aug 2012 - date	SiVEST SA (Pty) Ltd - Graduate Environmental Consultant
June 2011 - Aug 2012	Arcus GIBB – Junior Environmental Scientist, Internship

Language Proficiency

LANGUAGE	SPEAK	READ	WRITE
English	Fluent	Fluent	Fluent
Afrikaans	Fair	Good	Fair

Key Experience

Veronique joined SiVEST in August 2012 as is based in the Johannesburg office in the capacity of a Graduate Environmental Consultant.

Veronique has been involved extensively in the public participation aspect on numerous projects including environmental impact assessments, water use license applications and amendment impact assessments. She has been involved in the compilation of Environmental Impact Assessment (EIA) and Basic Assessments (BA) and Environmental Management Plans primarily related to energy generation and electrical distribution projects. She also assists and undertakes visual impact assessments, by making use of ArcGIS technology and undertaking field surveys.

Previously worked for Arcus GIBB (Pty) Ltd and assisted with the compilation of Basic Assessments (BA) and Environmental Impact Assessments (EIA). She also performed Environmental Control officer work and assisted in Public Participation meetings and the overall public participation process.

She is proficient in Microsoft Office, Microsoft Excel, Microsoft PowerPoint, ArcGIS, Maximiser and Adobe.

Through her time at SIVEST, Veronique has acquired the following skills:

- Strong proposal and report writing skills;
- Report compilation skills for Environmental Impact Assessments and Basic Assessments;
- Report compilation skills for Environmental Management Plans/Programmes;
- Strong public participation skills and the use of Maximiser; and
- Compilation and conducting Visual Impact Assessments.

Key experience includes:

- Environmental Impact Assessment (EIA) of small, medium and large-scale infrastructure projects,
- Basic Assessment (BA), of small, medium and large-scale infrastructure projects,
- Environmental Management Plans (EMPr), of small, medium and large-scale infrastructure projects,
- Public Participation Process,
- Proposal and tender compilation,
- Various site inspections, and
- Visual Impact Assessments.

Project Experience

SIVEST GRADUATE ENVIRONMENTAL CONSULTANT AUG 2012 TO DATE

ENVIRONMENTAL MANAGEMENT AND IMPACT ASSESSMENT

Responsible for task management to ensure that the EIA/BA process was implemented correctly, on schedule, the EIA/BA process includes applications, baseline assessments, EIA/BA reports and Environmental Management Plans (EMPr).

- Basic Assessment (BA) and Environmental management Plan (EMPr) for the proposed construction of a 132kv Power Line, Substation and the extension of Homestead Substation associated with the Concentrating Photovoltaic (CPV) / Photovoltaic (Pv) Plant (PV 3) on the Farm Droogfontein in Kimberley, Northern Cape Province (2012/2013);
- Basic Assessment (BA) and Environmental Management Programme (EMPr) for the Proposed Mookodi Integration Phase 2 132kv Power Lines and Ganyesa Substation Near Vryburg, North West Province (2012);
- Basic Assessment (BA) for the upgrade of the Silver Lakes outfall sewer pipeline (2012);
- Basic Assessment (BA) and Environmental Management Programme (EMPr) for the Proposed construction of the Sheepmoor traction substation with two 20MVA transformer bays and a new associated 88kV turn-in power line, Mpumalanga Province (2013);
- Basic Assessment (BA) and Environmental Management Programme (EMPr) for the Proposed rebuild of the 88kV power line from Uitkoms substation to Antra T-off, Mpumalanga Province (2013);
- EIA for the proposed 25 MW Community Wind Farm in St Helena Bay, Western Cape Province. The EIA includes the scoping process and detailed environmental impact assessment. The project includes detailed specialist studies such as social, visual and biophysical as well as a full public participation process. Junior Environmental Scientist. Just Energy, 2011 -2012, closed.
- EIA for the proposed 300 MW Caledon Wind Farm, Western Cape Province. The EIA includes the scoping process and detailed environmental impact assessment. The project includes

- detailed specialist studies such as social, visual and biophysical as well as a full public participation process. Junior Environmental Scientist, GIBB. Caledon Wind, 2011 – 2012, closed.
- EIA and EMP for the proposed South African Nuclear Energy Corporation (Necsa) Dedicated Isotope Production Reactor (DIPR) at the Pelindaba Site near Hartebeespoort in the North West Province. The EIA includes the scoping process and detailed environmental impact assessment. The project includes detailed specialist studies such as social, visual and air quality as well as a full public participation process. Junior Environmental Scientist, GIBB. Necsa, 2011 -current.
 - BA for the proposed 25 MW Community Wind Farm in St Helena Bay, Western Cape Province. The BA includes the scoping process and detailed environmental impact assessments. The project includes detailed specialist studies such as social, visual and biophysical as well as a full public participation process. Junior Environmental Scientist, GIBB. Just Energy, 2012 - current.

PUBLIC PARTICIPATION

Responsible for task co-ordination of the Public Participation Process, involving the compilation of Public Participation documentation and reports, Comment and Response Reports, arranging and coordinating public meetings, management of Interested and Affected Party (I&AP) database's and day-to-day solicitation of comments and responses to and from I&APs. Projects included:

- Public Participation Process for the Proposed construction of the Sheepmoor traction substation with two 20MVA transformer bays and a new associated 88kV turn-in power line, Mpumalanga Province (2013/2014);
- Public Participation Process for the Proposed rebuild of the 88kV power line from Uitkoms substation to Antra T-off, Mpumalanga Province (2013/2014);
- Public Participation Process for the proposed construction of two solar photovoltaic (PV) plants on portion 6 (portion of portion 5) of the farm Spes Bona 2355 district in Bloemfontein, Free State (2013/2014);
- Public Participation Process for the proposed Construction of an 88kv power line from Klevebank Substation (Diepsloot) to Dalkeith Substation (Cosmo City), Gauteng Province (2013);
- Public Participation Process for the EIA and EMP for the proposed Eastside Junction mixed use development near Delmas, Mpumalanga Province (2013/2014);
- Public Participation Process for the Water use licence application for the proposed construction of an 11kv underground power cable at Ga-rankuwa Substation, Gauteng Province (2013/2014);
- Public Participation Process for the proposed Mookodi Integration Project Environmental Impact Assessment (2012/2013);
- Public Participation Process for the proposed for the Proposed Mookodi Integration Phase 2 132kv Power Lines and Ganyesa Substation Near Vryburg, North West Province(2011/2012)
- Public Participation Process for the proposed Environmental Impact Assessment of a wind farm near Noupoot, Northern Province (2012/2013);
- Public Participation Process for the proposed Renosterberg Wind Farm and PV Plant near De Aar, Northern Cape Province (2012);
- Public Participation Process for the proposed installation of a 500m³ Bulk Storage Fuel Oil Tank at Grootvlei Power Station, Mpumalanga Province (2011/2012);
- Public Participation Process for the proposed development of a 19MW Photovoltaic Solar Power Plant near Kimberley, Northern Cape Province (2012);
- Proposed development of a 19MW Photovoltaic Solar Power Plant near Kimberley, Northern Cape Province (2012);
- Proposed development of a 19MW Photovoltaic Solar Power Plant near Danielskuil, Northern Cape Province (2012);
- Public Participation Process for the proposed Frankfort Strengthening Project: 88kV power line from Heilbron (via Frankfort) to Villiers, Free State Province (2013),
- Public Participation Process for the proposed Construction of a 132KV Power Line Associated with the Redstone Solar Thermal Energy Plant in the Northern Cape Province. (2012);
- Public Participation Process for the proposed for the Proposed Development of a Solar Photovoltaic (PV) Power Plant and Wind Farm near De Aar, Northern Cape Province.

- Public Participation Process for the proposed construction of a 132kv Power Line Associated with the Concentrating Photovoltaic (CPV) / Photovoltaic (PV) Solar Infrastructure (PV 2) from the Farm Droogfontein to Eskom's Existing Macfarlane Substation north of Kimberley, Northern Cape Province (2012);
- Public Participation Process for the proposed Moloto Development Corridor (MDC) Project Located between the City of Tshwane Local Municipality in Gauteng Province and Groblersdal, Limpopo Province, Traversing Mpumalanga Province (2013)
- Environmental Impact Assessment (EIA) for the Proposed Eastside Junction Mixed Use Development near Delmas, Mpumalanga Province (2013)
- Public Participation Process for the proposed Construction of a 19mw Photovoltaic (PV) Power Plant on the remainder of Farm 267 near Arriesfontein, Northern Cape Province (2011/2012);
- Public Participation Process for the proposed Construction of a 7km 132kv Power Line and Substation near Postmasburg Northern Cape Province (2011/2012);
- Public Participation Process for the proposed Westrand Strengthening Project – 400kv Double Circuit Power Line from Westgate Substation to Hera Substation and Westgate Substation Extension, Gauteng (2012);
- Public Participation Process for the proposed for the development of a Wind Farm and Solar Photovoltaic Power Plant near Loeriesfontein, Northern Cape Province (2012);
- Public Participation Process for the proposed Construction of a Wind Farm near Noupoort, Northern Cape Province (2012)
- Public Participation Process for the proposed Construction of Solar Photovoltaic Facilities near Prieska, Northern Cape Province (2012)
- Public Participation Process for the proposed construction of a 132kv Power Line, Substation and the extension of Homestead Substation associated with the Concentrating Photovoltaic (CPV) / Photovoltaic (Pv) Plant (PV 3) on the Farm Droogfontein in Kimberley, Northern Cape Province (2012/2013)
- Public Participation Process for the proposed Water Use License for the Frankfort Strengthening Project: 88kV power line from Heilbron (via Frankfort) to Villiers, Free State Province (2013);
- Public Participation Process for the proposed Water Use License for an 88kV power line from Klevebank Substation to Dalkeith Substation, Gauteng Province (2013);
- Public Participation Process for the proposed Water Use License for an 11kV power line from Zola Substation to Civic Substation, Gauteng Province (2013).
- Public Participation Process for the proposed 25 MW Community Wind Farm in St Helena Bay, Western Cape Province. Junior Environmental Scientist, GIBB (2011);
- Public Participation Process for the proposed 300 MW Caledon Wind Farm, Western Cape Province. Junior Environmental Scientist, GIBB (2011);
- Public Participation Process for the proposed Dedicated Isotope Production Reactor (DIPR) for the South African Nuclear Energy Corporation (NECSA) at Pelindaba, North West Province. Junior Environmental Scientist, GIBB (2011).

WETLAND IMPACT ASSESSMENT

Field assistant for wetland impact assessments, wetland and riparian delineations:

- Construction of an 88kV Power Line at Lochvaal Kudu in the Emfuleni Municipality, Gauteng Province, South Africa: Surface Water Impact Assessment and Rehabilitation Plan (2013);
- Construction of the Sheepmoor traction substation with two 20MVA transformer bays and a new associated 88kV turn-in power line, Mpumalanga Province (2013)
- Rebuild of the 88kV power line from Uitkoms substation to Antra T-off, Mpumalanga Province (2013)

VISUAL IMPACT ASSESSMENT

- Visual Impact Assessment for the Proposed Development of a Solar Photovoltaic (PV) Power Plant and Wind Farm near De Aar, Northern Cape Province.

- Visual Impact Assessment for the Proposed construction of the Sheepmoor traction substation with two 20MVA transformer bays and a new associated 88kV turn-in power line, Mpumalanga Province
- Visual Impact Assessment for the Proposed rebuild of the 88kV power line from Uitkoms substation to Antra T-off, Mpumalanga Province

ENVIRONMENTAL CONTROL OFFICER

- Environmental Control officer Services for the Orange Farm road upgrade project, Gauteng Province. ECO Junior Environmental Scientist, GIBB (2012).

Personal Details

Surname : Broughton
 Names : Elena
 Date of Birth : 11 September 1980
 Nationality : Russian
 Residency : RSA Permanent Resident
 Profession : Senior Development Economist



Key Qualifications

Elena Broughton completed her BCom (Hon) in Economics in Russia, at Nizhny Novgorod State University in 2002 specialising in regional economics. At the same time, she completed an additional degree as Translator/Interpreter in Professional Orientated Communication. After completion of her Honours degree in Economics, Elena has moved to the USA and stayed there for 1.5 years. During her stay in the USA, she completed a number of Accounting and Business courses at Parkland College, Illinois. In 2007, she obtained her BSc (Hon) in Technology Management (Cum Laude) at the University of Pretoria and later received her MSC in Technology Management (2011) from the same university.

Elena Broughton is a senior professional at Urban-Econ and has an extensive knowledge in various fields of economic development, including impact assessments, investment strategy formulation, strategic decision analysis, and monitoring and evaluation. She is experienced in developing input-output and SAM-based models, as well as development and application of other econometric techniques. Elena has a special interest in project evaluation and decision-making framework, with the later being the focus of her Master's dissertation. Over the past few years, she was able to extend her experience in these fields working on projects for both government and the private sector.

Academic Qualifications

Institution (Date from – Date to)	Degree(s) or Diploma(s) obtained:
2008-2011	MSc in Technology Management
2006 - 2007	BSc (Hon) in Technology Management
2004, Parkland College, USA	Computer Integrated Accounting
2004, Parkland College, USA	Independent Business
2003, Parkland College, USA	Intermediate Accounting
2003, Parkland College, USA	Records Management
2003, Parklands College, USA	Financial Accounting
2003, Parklands College, USA	Managerial Accounting
2002, Nizhny Novgorod University, Russia	BCom (Hon) in Economics

Language Proficiency

	Reading	Writing	Speaking
Russian	Excellent	Excellent	Excellent
English	Excellent	Excellent	Excellent

Employment Record

2004: Urban-Econ: Development Economist

Projects Undertaken

- **Go to Market Strategy for a PV Panel Manufacturer:** Urban-Econ Development Economists together with EScience Associates and Tracy Stewart Consulting was appointed by the CEF to undertake a Go-to-Market Strategy for a PV panel manufacturing facility. The project comprised of two major parts. The first components included the analysis of the market and opportunities presented in the market, as well as identification of the needs, affordability levels, and requirements by all groups of stakeholders comprising the industry's value chain. The second part of the study included the formulation of the strategic plan that outlined various target markets to be pursued, value proposition to be offered, market channels to be considered for entering the market, and activities to be implemented during the product pre-launch, launch and post-launch phases.
- **SunCorp Socio-Economic and Enterprise Development Plan formulation:** Urban-Econ Development Economists was appointed by SunCorp to develop a Socio-Economic Development and Enterprise Development Plans for a solar PV project in the Free State. The plans were devised in line with the DOE requirements outlined for the bidding phase.
- **Savanna Cookware Manufacturing Facility Pre-Feasibility Study:** Urban-Econ Development Economists undertook a pre-feasibility study for a manufacturing facility planned to produce luxurious stainless steel cookware in South Africa. The pre-feasibility study focused on determining the need and desirability for the proposed manufacturing facility considering the defined primary and secondary markets; the key prerequisites for the viability of the proposed venture and the most optimal location for the proposed manufacturing facility.
- **An opportunity cost assessment for the proposed Labonte 5 mining project:** The purpose of the study was to investigate the opportunity cost of the proposed sand mining project to determine the implications on the local economy dynamics and the impact on the major infrastructure projects implemented in the Lephalale area if the proposed project is not approved.
- **Saldanha Bay Separation Plant Economic Impact Assessment:** The project involved undertaking an economic impact assessment study for the proposed construction and operation of a Rare Earth Elements (REE) Separation Plant on Portion 6 of the Farm Langeberg 188 in Saldanha, in the Western Cape Province. The study formed part of the Environmental Impact Assessment process as prescribed in the National Environmental Management Act (NEMA) of 1998 and its subsequent amendments.
- **Zandkopsdrift Rare Earth Elements (REE) Project Economic Impact Assessment:** The project involved undertaking an socio-economic impact assessment study for the proposed the Zandkopsdrift Rare Earth Elements (REEs) Project near Garies in the Northern Cape Province of South Africa. The study formed part of the Environmental Impact Assessment process as

prescribed in the National Environmental Management Act (NEMA) of 1998 and its subsequent amendments.

- **Balmoral EIA:** The study involved undertaking a socio-economic impact assessment as an input into a Basic Impact Assessment Study for the proposed Balmoral X5 Township Development in the Ekurhuleni Metropolitan Municipality (EMM).
- **Green Building Market Entry Study:** The Embassy of the Kingdom of the Netherlands in Pretoria appointed Urban-Econ Development Economists to undertake a market entry study for the Green Building industry of South Africa. The document was compiled for the purpose of guiding the existing or prospective Dutch companies in expanding or involving themselves in the South African Green Building industry. The report contained information on the policy and regulatory environment that drives the development of this sector in the country and the broad overview of the status of the construction industry with the focus on the green building industry. The document also encompassed information on the state of development and industry maturity of selected green building sub-sectors that are aligned with the expertise of the Dutch companies. Information on doing business in South Africa as far as procurement and tendering practices, business funding and other support offered by South Africa and Netherlands was also provided.
- **Royal Bafokeng Mining Procurement Study:** The study business opportunities that can be established in the area leading to the localisation of mining inputs. It was based on a comprehensive assessment of the selected mine's contract-based procurement practices.
- **Ventersburg Business Development Concept:** The study focused on the identification of business development opportunities that could be pursued in the town of Ventersburg based on the traffic derived in the area from the N1 highway and other regional roads. The study involved a comprehensive assessment of the target markets induced by traffic, economic base of the area, current business offerings and derived opportunities. It concluded with a presentation of business development concept scenarios and associated socio-economic benefits.
- **Northern Cape Renewable Energy Strategy:** Urban-Econ Development Economists with a support from EScience Associates and Centre for Renewable and Sustainable Energy Studies (CRSES) was appointed to develop a renewable energy strategy for the Northern Cape. The objective of the study was to undertake a situational assessment of the Northern Cape economy to identify the opportunities and constraints with respect to renewable energy development, and accordingly to formulate a plan to unlock the existing potential of the province to harness renewable energy to the benefit of its communities and economy and to position the province to attract a maximum share of investment under the IRP2010 Renewable Energy Target and beyond.
- **The localisation potential of Photovoltaics and a strategy to support large scale roll-out in South Africa:** A consortium comprising of EScience Associates, Urban-Econ Development Economists and Chris Ahlfeldt (the project team was appointed to undertake the study on the localisation potential of solar PV. The specific objectives of the study included profiling of the industry, analysis of the PV industry value chain, and development of the strategy for the future roll-out of the industry in the country.
- **Feasibility study into establishing CSP component manufacturing facilities in South Africa:** The Industrial Development Corporation (the IDC) has commissioned Urban-Econ Development Economists supported by EScience Associates to undertake a feasibility study to determine the viability of the establishment of a manufacturing facility of CSP modules and components in South Africa.
- **Eskom CSP Macro-Economic Impact Assessment:** Eskom CSP (Solar 1) Macroeconomic Impact Assessment: The study involved the identification of potential localisation opportunities for various components of the project and modelling of the socio-economic impacts.



-
- **Proposed Exxaro IPP Coal-Powered Power Station near Lephalale, Limpopo Scoping Inputs:** Urban-Econ Development Economists was appointed to undertake a Socio-Economic Scoping Study and Land Use Impact Study for the proposed Exxaro coal-powered power station near the town of Lephalale, in the Limpopo province.
 - **Mafube Nooitgedacht and Wildfontein EIA/EMP Sustainable Development Investigation Study:** Urban-Econ Development Economist was appointed to undertake an investigation into sustainable development options associated with the proposed project. The results of this study aimed at informing the decision makers of socio-economic trade-offs related to each option analysed and the most preferred alternative.
 - **Thaba Metsi Sustainable Development Investigation Study:** The objective of the Thabametsi Project is to mine coal via opencast and underground mining methods for supply to the Independent Power Producer (IPP) coal-fired power station, to be developed by Exxaro north of the proposed Thabametsi project. Urban-Econ Development Economists provided a specialist input into the sustainable development Investigation that aimed to quantify and assess various options associated with the development and post-mining land uses that formed part of an input into the EIA report.
 - **Eskom Sere Wind (WEF1) Macro-Economic Impact Assessment:** The project entailed the strategic assessment of the proposed facility on the macroeconomic situation with respect to the impact on the balance of payments, supply of energy, demand for water, and achievement of strategic government objectives. It also entailed the assessment of the proposed project on the regional and local economies.
 - **Socio-Economic and Economic Impact Assessment Studies for Renewable Energy Projects** conducted as part of the Environmental Impact Assessment Processes
 - Arriesfontein Solar Energy Park near Danielskuil in the Northern Cape (100 MW CSP-Tower facility and 225 MW PV solar facility)
 - Humansrus Solar Energy Facility near Postmasburg in the Northern Cape (100 MW CSP-Tower facility)
 - Rooipunt Solar Energy Park near Upington in the Northern Cape (100 MW CSP-Tower facility and 215 MW PV solar facility)
 - Farm 198 PV Solar Energy Facility north of Kimberley in the Northern Cape (210 MW PV solar facility)
 - Wag'nbiekiespan PV Solar Energy Facility near Boshof, the Free State Province (75 MW PV solar facility)
 - **Energy-Related Proposals Evaluation for the Department of Science and Technology:** Urban-Econ Development Economists was appointed to undertake an evaluation of six energy-related proposals submitted to the DST SBS. The objective of the evaluation is to advise the Department on whether the projects described in the proposals should be funded or not. The assessment takes into account operational and financial feasibility of projects, alignment thereof with government objectives, economic benefits derived from the project, ability of the organisations to implement the projects successfully and a risk assessment. The project also involves the development of a decision framework on the basis of a Multi-Criteria Decision Method that will be used to compare proposals and determine the one that are not only suitable for funding but those that should be prioritised above others.
 - **Independent evaluation of the Wireless Mesh Network in Government Broadband:** Urban-Econ Development Economists was appointed to undertake an independent evaluation of the Community Wireless Mesh Networks in the Government Broadband project. Urban-Econ's responsibility is to evaluate the progress of the project to this date and provide recommendations that can be implemented to improve its design and execution.
 - **Department of Science and Technology Economic Analysis Model:** Urban-Econ was appointed by the Department of Science and Technology (DST) to assist them in developing a
-

decision-making framework that would allow them to evaluate various proposals from an economic perspective and identify the ones that would create the largest economic benefits.

- **Eskom Ariadne-Eros Power Lines Economic and Agricultural Impact Assessment:** Urban-Econ was appointed to undertake an Agricultural Potential and Economic Impact Assessments for the proposed Ariadne-Eros transmission power line, and expansion and upgrade of the related substations in KwaZulu-Natal.
 - **Eskom Ingula Pumped Storage Scheme Regional Economic Impact Assessment:** The purpose of the study was to present an assessment of socio-economic impact of the Ingula Pumped Storage Scheme on the national and regional economies.
 - **Gauteng Infrastructure Renewal and Investment Plan (GIRIP):** the study involved the formulation of an infrastructure and renewal plan up until 2025 that would transform Gauteng into a competitive Global City-Region. As part of the study a regional model with necessary demographic and economic projects was developed that assisted in identifying future infrastructural needs in the Province.
 - **De Hoop Dam Economic Impacts Monitoring Framework:** Urban-Econ was approached to develop and set up an integrated and coherent monitoring and evaluation reporting system which will primarily be based on a regional impact assessment model framework to monitor and evaluate the regional socio-economic impacts due to the development of the De Hoop dam
 - **North West Cluster Performance Analyses:** Urban-Econ was appointed by the North West Office of the Premier to undertake the analyses of statistics tables for six clusters (Human Resource Development, Physical Assets, Resource Base, Governance and Protection, Economic, and Social), identify areas that require interventions, and proposes possible solutions to address the key challenges.
 - **Mopani Investment Strategy:** Urban-Econ Development Economists was appointed by the Mopani District Municipality to formulate an investment strategy for the region with a focus of promoting integrated and sustainable development in the local economy.
 - **Socio-Economic Impact Assessment Of The Proposed Route Operator Business In Mpumalanga:** The project entailed assisting with the preparation of the response to the Request for Applications in respect of Limited Payout Machine Licences in the Mpumalanga Province. The assistance requested encompassed a macro-level socio-economic analysis of the proposed route operator business in Mpumalanga with a focus on: (a) benefits to the economy in terms of gross geographical product ("GGP"), employment creation, increased household income, skills development, and small, medium, micro enterprise ("SMME") development and (b) potential social impact of gaming in the Province.
 - **N3 Highway Economic Impact Assessment:** Urban-Econ was appointed to determine the Socio-Economic Impact of the proposed re-routing of the N3 highway around Harrismith and the current link with the N5 Route towards Lesotho and Mangaung.
 - **The Mandela Bay Precinct Economic Impact Assessment:** The study entailed conducting an economic impact assessment of the proposed Mandela Bay Precinct Development in Port Elizabeth. The proposed project was a mixed use development with the main component being a Regional Shopping Centre that will be surrounded by high density residential property, filling stations, light industrial space, a hospital, a hotel, and office space.
-

-
- **The City of Windhoek Draft SME Policy:** Urban-Econ was appointed by the City of Windhoek (COW) Local Authority to develop a Draft SME Development Policy Directive to guide future SME promotion and development in the City of Windhoek
 - **Harrismith Logistics Hub Impact Assessment:** Urban-Econ Development Economists was appointed to undertake a rapid economic impact assessment study of the proposed Harrismith Freight Logistics Hub (“HLH”). The aim of the study was to determine potential benefits that could be created by the HLH in terms of unlocking the latent development of the area. This technical memorandum presents the results of the study.
 - **Megamall Economic Impact Assessment:** Urban-Econ was requested to undertake an economic impact study for the Megamall project to be developed in the Mogale City Local Municipality. The aim of the study was to determine the potential economic impacts emanating from the proposed development. This study involved assessment of socio-economic impacts the proposed project could have on the local economy which could be used in application for funding from commercial banks and government.
 - **Coega Ridge Economic and Social Impact Assessments:** Urban-Econ was appointed to undertake economic and social impact assessment of the proposed Coega Ridge development. The aim of the development was to create a unique and sustainable residential enclave encompassing a “live, work, play, and shop” environment and comprising such components as affordable housing, shopping centre, office park, industrial park, community and social facilities, bulk service infrastructure, and public open space.
 - **Amanzi Economic and Social Impact Assessments:** Urban-Econ was requested to undertake an economic and social impact studies for the proposed Amanzi Estate that included the original homestead of Sir Percy Fitzpatrick, author of Jock of the Bushveld
 - **Limpopo Industrial Parks Resuscitation Assessment:** Urban-Econ was appointed to assess the feasibility of resuscitation of the selected industrial parks in the Limpopo Province. Study included analysis of the economic potential of the selected areas, development of scenarios and formulation of recommendations. Managed the team of sub-consultants.
 - **North West PGDS Monitor 2007:** the study encompasses a comprehensive analysis and projections of the achievement of the PGDS targets, reviewing the performance of the Working Groups, and providing recommendations regarding actions needed to be taken to address the shortfalls.
 - **Sedibelo Economic Impact Assessment:** The study involved conducting a economic impact assessment of the proposed development utilising an Input/Output model.
 - **Mooifontein Coal Mine Comparative Analysis, Mpumalanga:** Urban-Econ Development Economists were appointed to undertake a sustainable development investigation exercise that includes a comparative economic analysis between the status quo, i.e. farming, and an alternative land use, i.e. mining. The study made use of the economic modelling techniques to estimate the contribution of the current activities towards the country's economy and the expected contribution of the proposed scenario. The impacts were calculated for a period of 100 years and compared to identify the most beneficial scenario from an economic perspective.
 - **Hanglip Sustainability Model:** Urban-Econ was appointed to develop a model that would have assisted the decision makers in identifying the most preferred alternative/s for the Hanglip Development. The model was based on the multi-criteria decision-making process.
-

-
- **Emalahleni Investment Incentive Package:** Urban-Econ was appointed by the Emalahleni Local Municipality to update the Investment Incentive Package for the Emalahleni Local Municipality.
 - **Eastern Cape Industrial Sector Study:** Urban-Econ EC was appointed by the Eastern Cape Socio-Economic Consultative Council (ECSECC) to undertake an industrial sector study for the Eastern Cape Province. The study is envisioned to provide inputs to the Provincial Industrial Strategy that is currently being prepared. The focus of the strategy is on provision of support to the sectors with the potential for job creation in the Province. In this context, this study aims at identifying the sectors that have the highest potential for uplifting the second economy in the Province and highlighting their growth barriers.
 - **Socio-Economic Impact Assessment of the Proposed New Eskom Power Stations in the Witbank Geographical Area and Northern Free State:** The study involved conducting a socio-economic impact assessment of the proposed developments utilising an Input/Output model.
 - **Sedibeng Investment Incentive Package:** The study encompasses a formulation of an incentive package that would enhance development and investment in the area, as well as promote economic growth. A comprehensive socio-economic analysis of the Sedibeng DM and its Local Municipalities, including growth potential was performed.
 - **North West Sustainable Development Indicators Pilot Project:** After completing the North West Sustainable Development Indicators, Urban-Econ was appointed to execute of the pilot project of population the framework.
 - **North West Sustainable Development Indicators:** Urban-Econ Development Economists have been appointed by the North West Province's Office of the Premier to formulate a Sustainable Development Indicator Framework for the North West Provincial Administration. The purpose of the framework is to assist the provincial government authority in the monitoring and evaluation of their progress towards achieving sustainable growth and development.
 - **Polokwane Trade Hub:** Urban-Econ Development Economists, assisted by Nyeleti Consulting Engineering, were appointed by Polokwane Municipality to undertake a Polokwane Trade Hub feasibility study. The feasibility study included investigation of the potential of Polokwane to develop into a regional trade, implications associated with its development, and the initiatives, including programmes and projects, that need to be implemented to realise the vision of Polokwane as a regional trade hub.
 - **Mpumalanga Job Creation Budget:** The project involved an assessment of the provincial budget with respect to its impact on job creation and identification of opportunities to enhance sustainable job creation in the Province.
 - **Joburg BPO Zone:** Urban-Econ was appointed to provide an urban-economic rationale and motivation for the selection of a BPO Precinct in the Joburg Inner City.
 - **The North West Barometer 2006: Economic Module Update.** Urban-Econ Development Economists have been appointed by the North West Province's Office of the Premier to formulate a Sustainable Development Indicator Framework for the North West Provincial Administration. This report details the project roll-out plan and project progress to date.
 - **Bekkersdal Skills and Entrepreneurship Development Strategy.** The Bekkersdal Skills and Entrepreneurship Development Strategy provides the reader with thorough data on the existing pool of enterprises and entrepreneurs, services and products; and existing skills in
-

Bekkersdal, which can be utilized by public and private entities. The document includes Skills Audit and Business Audit Databases in Access format.

- **Baralink economic and market study.** Urban-Econ: Development Economists have been appointed by Urban Dynamics to undertake an economic and market study of four areas, namely, Baralink, JP's Town, Orange Farm, and Kwadzudza; and provide the feedback on potential economic activates that can be introduced to the area in regard to promotion of sustainable livelihoods. This study forms a part of a more comprehensive analysis of the abovementioned areas, the purpose of which is to compile a strategy for sustainable housing development, according to the new housing policy, in different regions of Johannesburg Metropolitan area.
 - **Business Improvement District Strategy for Bekkersdal.** Due to the low levels of consumer and business confidence in the Bekkersdal CBD, this project required the formulation of a strategy for the establishment and implementation of a BID for the CBD area of Bekkersdal.
 - **Expansion of Holcim Cement Plant: Economic Impact Assessment.** Urban-Econ has been appointed to assess economic impact of the expansion of Holcim Cement plant in Roodepoort.
 - **Madiba Bay Leisure Park Regional Mall Market Study.** Urban-Econ: Development Economists were commissioned by East Cape Showcase (Ltd.) to conduct empirical market research and compile a specialist market study for the proposed regional retail mall within the North Gate precinct of the Madiba Bay Leisure Park project.
 - **Social and Labour Plan for Brandbach Mine, Cullinan.** Mining industry is a cornerstone of the South African economy. So far it has experienced rises and downfalls. In order to insure sustainable development of the industry in the future along with the implementation of national visions on skills development, poverty alleviation, BEE and employment creation, the government has introduced a Skills and Labour Plan, preparation of which became a prerequisite for every mine in the country. Urban-Econ's suster company, Econo-Mine, has been appointed to develop such plan for the Brandbach Mine in Cullinan.
 - **NIPS for POPS Economic Impact:** Urban-Econ has been appointed as part of a specialist team to undertake the economic impact assessment of Infrastructure related to Persistent Organic Pollutants (POPS) in South Africa. The focus of the assessment is to formulate clear strategic guidelines related to the impacts of POPS and or their removal/eradication for the Development of National Implementation Plans (NIPS) of the Stockholm Convention on POPS.
-

Keagan Allan Senior Scientist



Profession: Senior GIS Specialist

Education: BSc Geographical Science – 2003
BSc (Hons) Geographical Science and Environmental Management – 2004
MSc Geographical Science (Cum Laude) – 2007

**Registrations/
Affiliations:** Registered Professional Natural Scientist (Pr.Sci.Nat),
South African Council for Natural Scientific Professions
(SACNASP), 400185/13
IAIA South Africa

Specialisation: Geographical Information Systems and Remote Sensing

Expertise:

Keagan has been involved in the following fields of expertise:

- Geographical Information Systems (GIS), more specifically data collection and manipulation; modelling of various spatial data for Visual Impact Assessments and Ground Water management and database management;
- GIS Development – using Visual Basic scripting to develop tools for use within the ESRI ArcMap environment;
- GIS in Environmental Management Frameworks – using Visual Basic in conjunction with GIS techniques to generate information for use in the GIS reporting in an EMF study;
- Remote Sensing (RS) more specifically the use of remotely sensed images in the classification of various land use types.

Employment Record:

Feb 2007 – August 2007 :	UKZN Pietermaritzburg,	Cartographic Technician
Feb 2008 – June 2008 :	Haley Sharpe Southern Africa,	Assistant Tourism Planner
July 2008 – Present :	SRK Consulting, Westville,	Environmental Scientist

Languages: English, Afrikaans

Publications: ALLAN, K., EMANUAL, P., and MORRIS, J.(2010) Poster Presentation: **Applications of GIS in EMF**, IAIA Conference, Pretoria, August, 2010.

Awards: Won Best Poster at the 2010 IAIA Conference – Poster **Applications of GIS in EMF**

Keagan Allan Senior Scientist

Key Experience:

- Name of Project:** Olifants Water Reserves
Client: SRK - JNB
Location: Limpopo Province
Project Description: Assessment of the water reserves in the Olifants River Catchment
Project duration/date: July 2008 – November 2009
Job Title and Duties: GIS Specialist and modelling of groundwater levels
- Name of Project:** ESKOM: Makhatini EIA
Client: ESKOM
Location: Makhatini, KZN
Project Description: The development of a new 22 kV power line through the Makhatini Flats area
Project duration/date: July 2008 - present
Job Title and Duties: GIS Specialist – mapping and modeling
- Name of Project:** Shell Wavecrest Environmental Impact Assessment (EIA)
Client: Shell South Africa
Location: Pinetown, KZN
Project Description: EIA for the refurbishment of the Shell Wavecrest Service Station, Sarnia, Pinetown
Project duration/date: July 2008 - present
Job Title and Duties: Environmental Scientist, Reporting, Public Participation, Field Work.
- Name of Project:** Petroline Visual Impact Assessment
Client: SRK – JNB
Location: Alkmaar, Mpumalanga
Project Description: The identification of potential visual impacts the development of a storage depot might have on the surrounding area
Project duration/date: August 2008 – October 2008
Job Title and Duties: GIS Specialist – mapping and modeling; reporting.
- Name of Project:** ESKOM – Pebblebed Reactor EIA and Risk Assessment
Client: SRK – CPT
Location: Western Cape
Project Description: Various EIAs and Risk Assessments for the placement of the proposed Pebble bed Nuclear Reactors.
Project duration/date: August 2008 – November 2008
Job Title and Duties: GIS Specialist – mapping of the various factors for the project
- Name of Project:** Riverhorse as-built floodlines
Client: eThekweni Municipality
Location: Durban North, KZN
Project Description: Flood modeling along a section of the Riverhorse Valley Industrial Park.
Project duration/date: August 2008 – November 2008
Job Title and Duties: GIS Specialist – mapping and modeling of the terrain
- Name of Project:** Styldrift Mine – Visual Impact Assessment
Client: SRK – JNB
Location: Rustenburg, North West Province
Project Description: Undertaking of a visual impact assessment for the Styldrift Mining Complex
Project duration/date: November 2008 – January 2009
Job Title and Duties: GIS Specialist – mapping and modeling; reporting.

- Name of Project: Basic Assessment for the Palmiet River Attenuation
 Client: eThekweni Municipality
 Location: Pinetown, KZN
 Project Description: Undertaking a Basic Assessment for the proposed flood attenuation of the Palmiet River Catchment, Pinetown
 Project duration/date: October 2008 – February 2009
 Job Title and Duties: Environmental Scientist, Reporting, Public Participation, Field Work.
- Name of Project: Dwaalkop VIA
 Client: Messina Platinum Mines Ltd.
 Location: Lebowakgomo, Limpopo
 Project Description: Visual Impact Assessment for the Dwaalkop Mining Operation, Limpopo
 Project duration/date: February 2009 – February 2009
 Job Title and Duties: GIS Specialist – mapping and modeling; reporting.
- Name of Project: Mshwati EMF
 Client: INR
 Location: Mshwati Municipality
 Project Description: Undertaking floodline assessments and service assessment for the Mshwati EMF
 Project duration/date: July 2009 – November 2009
 Job Title and Duties: GIS Specialist – mapping and modeling; reporting.
- Name of Project: City of Cape Town – Stormwater Asset Project
 Client: City of Cape Town
 Location: Cape Town
 Project Description: Assessment of stormwater assets in the City of Cape Town Municipality
 Project duration/date: August 2009 – September 2013
 Job Title and Duties: GIS Specialist – mapping and modeling; reporting.
- Name of Project: Vlakfontein Mine VIA
 Client: SRK – JNB
 Location: Ogies, Mpumalanga
 Project Description: Visual Impact Assessment for the proposed opencast coal mining operations on the Vlakfontein Farm, Ogies, Mpumalanga
 Project duration/date: October 2009 – November 2009
 Job Title and Duties: GIS Specialist – mapping and modeling; reporting.
- Name of Project: Hilton Housing Estate VIA
 Client: Environmental Planning and Design
 Location: Hilton, KZN
 Project Description: Visual Impact Assessment for the proposed housing estate on the Hilton College School grounds
 Project duration/date: November 2009 – January 2010
 Job Title and Duties: GIS Specialist – mapping and modeling; reporting.
- Name of Project: Amajuba District Municipality Disaster Management Plan
 Client: Amajuba District Municipality
 Location: Amajuba Municipality
 Project Description: Disaster management plan for the district
 Project duration/date: January 2010 – January 2011
 Job Title and Duties: Data collection

Name of Project: Msunduzi EMF
 Client: Msunduzi Municipality
 Location: Pietermaritzburg, KZN
 Project Description: Development of an EMF and SEA for the management of development in the Msunduzi Municipality
 Project Duration/date: July 2008 – May 2010
 Job Title and Duties: GIS Analyst, Spatial Decision Support Tool Programmer

Name of Project: Kriel EMPR Addition Reserves VIA
 Client: SRK- JNB
 Location: Kriel Mpumalanga
 Project Description: Visual Impact Assessment for the proposed opencast coal mining operations near the Kendal Power Station and Kriel, Mpumalanga
 Project duration/date: January 2010 – present
 Job Title and Duties: GIS Specialist – mapping and modeling; reporting.

Name of Project: MONDI – Phase 1 EIA
 Client: Mondi Richards Bay Mill
 Location: Richards Bay
 Project Description: EIA for a proposed expansion of the Mondi Richards Bay Mill
 Project duration/date: April 2010 – December 2010
 Job Title and Duties: GIS Specialist and Environmental Assessment Practitioner

Name of Project: EMF for the Msukaligwa and Albert Luthuli Municipalities (includes Mpumalanga Lake District region)
 Client: Mpumalanga Department of Agriculture and Land Administration
 Location: Mpumalanga Province
 Project Description: Development of an EMF tool for decision makers in the local municipalities
 Project Duration/date: August 2010
 Job Title and Duties: Spatial Decision Support Tool Programmer

Name of Project: Chevron – Water Quality Assessments
 Client: Chevron
 Location: KZN
 Project Description: Various mapping for a number of Chevron sites around KwaZulu-Natal
 Project Duration/date: January 2010 - present
 Job Title and Duties: Cartographer

Name of Project: Cape Winelands EMF
 Client: Cape Winelands District Municipality
 Location: Western Cape Province
 Project Description: Development of an EMF for the district municipality, as well as a GIS tool for assisting decision makers
 Project Duration/date: December 2010 – February 2012
 Job Title and Duties: GIS Analyst, Spatial Decision Support Tool Programmer

Name of Project: New Clydesdale Coal - VIA
 Client: Exxaro
 Location: Mpumalanga Province
 Project Description: Visual Impact Assessment for the consolidation of the existing EMPr and a proposed expansion to mining activities at the New Clydesdale Mine
 Project Duration/date: January 2011 – February 2012
 Job Title and Duties: GIS Analyst and Visual Assessment Practitioner

Name of Project: Venetia Mine EMPr Consolidation and VIA
 Client: De Beers
 Location: Limpopo Province
 Project Description: Visual Impact Assessment for the consolidation of the existing EMPr and a proposed expansion to mining activities at the Venetia Mine
 Project Duration/date: February 2011 – June 2011
 Job Title and Duties: GIS Analyst and Visual Assessment Practitioner

Name of Project: SATO Solar Power Plant VIA
 Client: SATO Holdings
 Location: Black Mountain – Northern Cape
 Project Description: Visual Impact Assessment for a proposed solar power plant, located near Black Mountain in the Northern Cape
 Project Duration/date: June 2011 – February 2012
 Job Title and Duties: GIS Analyst and Visual Assessment Practitioner

Name of Project: Dobbin Solar Power Plant VIA
 Client: Afrom Energy (Pty) Ltd.
 Location: Eastern Cape
 Project Description: Visual Impact Assessment for the proposed solar power generation facility near Dobbin, Eastern Cape
 Project Duration/date: February 2012 – October 2012
 Job Title and Duties: GIS Analyst and Visual Assessment Practitioner

Name of Project: Brakpoort Solar Power Plant VIA
 Client: Afrom Energy (Pty) Ltd.
 Location: Northern Cape
 Project Description: Visual Impact Assessment for the proposed solar power generation facility near Victoria East, Northern Cape
 Project Duration/date: February 2012 – October 2012
 Job Title and Duties: GIS Analyst and Visual Assessment Practitioner

Name of Project: Visual Impact Assessment for the Proposed Candover-Mbazwana-Gezisa 132kV Powerlines and 132/22kV 20MVA Mbazwana and Gezisa Substations, Northern KwaZulu- Natal
 Client: Eskom Holdings SOC Ltd.
 Location: KwaZulu-Natal
 Project Description: Visual Impact Assessment of the proposed new line
 Project Duration/date: May 2011 – November 2012
 Job Title and Duties: GIS Analyst and Visual Assessment Practitioner

Name of Project: Bush clearing specification compiled for the Nondabuya-Ndumo 132kV powerline and the Ndumo 132/22kV substation
 Client: Eskom Holdings SOC Ltd.
 Location: KwaZulu-Natal
 Project Description: Using remote sensing to identify and cost for bush clearing contractors to clear vegetation from the proposed powerline route
 Project Duration/date: February 2012 – May 2012
 Job Title and Duties: GIS Analyst and Remote Sensing Specialist

Name of Project: Rinaldo East Industrial Site Visual Impact Assessment
 Client: SiVest (Pty) Ltd.
 Location: KwaZulu-Natal
 Project Description: Visual Impact Assessment for the proposed new industrial site adjacent the N2 freeway in eThekweni
 Project Duration/date: November 2012 – July 2014
 Job Title and Duties: GIS Analyst and Visual Assessment Practitioner

- Name of Project: Visual Impact and Shadow Analysis of the Proposed Billboard on top of Nedbank House, Durban Central Business District
 Client: Primedia (Pty) Ltd
 Location: KwaZulu-Natal
 Project Description: Visual Impact Assessment and shadow analysis of a new billboard on the Nedbank House in the CBD of Durban
 Project Duration/date: December 2012
 Job Title and Duties: GIS Analyst and Visual Assessment Practitioner
- Name of Project: Visual Impact Assessment for a proposed 500 MW Solar Power Generation Facility
 Client: Savannah Environmental
 Location: Northern Cape
 Project Description: Visual Impact Assessment for a proposed solar generation facility, Northern Cape South Africa
 Project Duration/date: February 2013
 Job Title and Duties: GIS Analyst and Visual Assessment Practitioner
- Name of Project: Visual Impact Assessment for Phase 1 and 2 projects of the Styldrift Mining Complex
 Client: LonMin
 Location: North West
 Project Description: Visual Impact Assessment for proposed new ventilation shafts and waste rock dumps at the Styldrift Mining Complex, North West Province
 Project Duration/date: March 2013 – November 2013
 Job Title and Duties: GIS Analyst and Visual Assessment Practitioner
- Name of Project: Visual Impact for the proposed new mining complex at the Pandora Mining Complex
 Client: AVD Environmental (LonMin)
 Location: North West
 Project Description: Visual Impact Assessment for a proposed new mining complex and powerline at the Pandora Mine, north West Province
 Project Duration/date: July 2013 – September 2013
 Job Title and Duties: GIS Analyst and Visual Assessment Practitioner
- Name of Project: Visual Impact of Proposed Billboards along main roads in Port Elizabeth
 Client: Primedia (Pty) Ltd
 Location: Eastern Cape
 Project Description: Visual Impact of Proposed Billboards along main roads in Port Elizabeth
 Project Duration/date: December 2013
 Job Title and Duties: GIS Analyst and Visual Assessment Practitioner
- Name of Project: Groundwater Resource Directed Measures: Mvoti to Umzimkulu Water Management Area
 Client: DWAF
 Location: KwaZulu-Natal Province
 Project Description: Assessment of the groundwater water reserves in the Mvoti to Umzimkulu Water Management Area
 Project duration/date: July 2012 – July 2014
 Job Title and Duties: GIS Specialist and modelling of groundwater levels

Name of Project: Emadlangeni Rural Water Supply Desktop Groundwater Assessment
Client: Amajuba Municipality
Location: KwaZulu-Natal Province
Project Description: Assessment of borehole distribution and borehole conditions for the supply of water in the Emadlangeni Municipality, KwaZulu-Natal
Project duration/date: August 2013 – present
Job Title and Duties: GIS Specialist and analyst



Appendix 3: Authority Consultation

SIVEST
Environmental
Division

51 Wessel Road
PO Box 2921
Rivonia
2128 South Africa

Phone + 27 11 798 0600
Fax + 27 11 803 7272
Email info@sivest.co.za
www.sivest.co.za



Established in 1952

Department of Environmental Affairs
Environment House
473 Steve Biko
Arcadia
PRETORIA
0083

Our reference: 13031

Date: 05 December 2014

ATTENTION: THE DIRECTOR FOR EIA

Dear Sir/Madam

**HELENA SOLAR 2: 75 MW SOLAR PHOTOVOLTAIC (PV) ENERGY FACILITY NEAR
COPPERTON, NORTHERN CAPE PROVINCE**

**APPLICATION FOR ENVIRONMENTAL AUTHORISATION: ENVIRONMENTAL IMPACT
ASSESSMENT FOR THE PROPOSED CONSTRUCTION OF A 75 MW SOLAR PLANT WIND
FARM AND ASSOCIATED INFRASTRUCTURE NEAR COPPERTON, NORTHERN CAPE
PROVINCE**

Please find attached herewith an Application Form for Environmental Authorisation for the above-mentioned proposed project.

Your review and acceptance of the attached application form will be appreciated.

Yours sincerely

Rebecca Thomas
Environmental Consultant
SIVEST Environmental Division

Incl: Application Form for Environmental Authorisation (Including Appendices)

Divisional Director W A Pearce (Managing)
A Division of SIVEST Directors S D Leach (Chairman), M J Wright (Managing), S G Joubert, M J Meikle-Braes, W A Pearce,
H G D Regnaud, G R Sims, K P Smith, K Soni, A F Tomkins
Offices: South Africa Durban, Johannesburg, Ladysmith, Pietermaritzburg, Richards Bay, Cape Town. Africa Harare (Zimbabwe).

Part of the SIVEST Group

SIVEST SA (Pty) Ltd Registration No. 2000/006717/07 t/a SIVEST



1952 - 2012
60
YEARS
OF EXCELLENCE



environmental affairs

Department:
Environmental Affairs
REPUBLIC OF SOUTH AFRICA

Private Bag X 447 · PRETORIA · 0001 · Environment House · 473 Steve Biko Road · ARCADIA
Tel (+ 27 12) 399 9372

DEA Reference: 14/12/16/3/3/2/766

Enquiries: Ms Mmatlala Rabothata

Tel: 012 399 9372 E-mail: mrabothata@environment.gov.za

Ms Andrea Gibb
SiVEST SA (Pty) Ltd
PO Box 2921
RIVONIA
2128

Fax: 011 803 7272
Tel: 011 798 0638
Email: andreas@sivest.co.za

PER FACSIMILE / MAIL

Dear Ms Gibb

ACKNOWLEDGEMENT OF RECEIPT AND ACCEPTANCE OF A NEW APPLICATION FOR ENVIRONMENTAL AUTHORISATION (SCOPING/EIA PROCESS) FOR THE PROPOSED HELENA SOLAR 2, 75MW SOLAR PHOTOVOLTAIC (PV) ENERGY FACILITY NEAR COPPERTON WITHIN SIYATHEMBA LOCAL MUNICIPALITY IN NORTHERN CAPE PROVINCE

The Department confirms having received the application form with proof of payment, proof of notification of land owners, project map, project schedule, Declaration of Applicant and Declaration of EAP for environmental authorisation for the abovementioned project submitted by you on 5 December 2014. You have submitted these documents to comply with the Environmental Impact Assessment Regulations, 2010. The application is accepted.

Please note that should you have any administrative related queries, do not hesitate to contact the writer. Should you have any project specific queries on the abovementioned application, you are advised to contact: Mr Muhammad Essop; Telephone Number: (012) 399 9406; Email Address: MEssop@environment.gov.za

In addition, please consider the following during compilation of reports for this application for environmental authorisation:

- Please be advised that in terms of the EIA Regulations and NEMA the investigation of alternatives is mandatory. Alternatives must therefore be identified, investigated to determine if they are feasible and reasonable. It is also mandatory to investigate and assess the option of not proceeding with the proposed activity (the "no-go" option).
- Should water, solid waste removal, effluent discharge, stormwater management and electricity services be provided by the municipality, you are requested to provide this office with written proof that the municipality has sufficient capacity to provide the necessary

services to the proposed development. Confirmation of the availability of services from the service providers must be provided together with the reports to be submitted.

- In the reports to be submitted it must clearly be demonstrated in which way the proposed development will meet the requirements of sustainable development. You must also consider energy efficient technologies and water saving devices and technologies for the proposed development. This could include measures such as the recycling of waste, the use of low voltage or compact fluorescent lights instead of incandescent globes, maximising the use of solar heating, the use of dual flush toilets and low-flow shower heads and taps, the management of storm water, the capture and use of rainwater from gutters and roofs, the use of locally indigenous vegetation during landscaping and the training of staff to implement good housekeeping techniques.
- A detailed and complete EMPr must be submitted with the EIR. This EMPr must not provide recommendations but must indicate actual remediation activities which will be binding on the applicant. Without this EMPr the documents will be regarded as not meeting the requirements and will be returned to the applicant for correction.
- The applicant/EAP is required to inform this Department in writing upon submission of any draft report, of the contact details of the relevant State Departments (that administer laws relating to a matter affecting the environment) to whom copies of the draft report were submitted for comment. Upon receipt of this confirmation, this Department will in accordance with Section 24O(2) & (3) of the National Environmental Management Act, 1998 (Act 107 of 1998) inform the relevant State Departments of the commencement date of the 40 day commenting period, or 60 days in the case of the Department of Water Affairs for waste management activities which also require a licence in terms of the National Water Act, 1998 (Act 36 of 1998).
- Should it be necessary to apply for a permit in terms of the National Heritage Resources Act, 1999 (Act 25 of 1999), please submit the necessary application to SAHRA or the relevant provincial heritage agency and submit proof thereof with the Environmental Impact Assessment Report. The relevant heritage agency should also be involved during the public participation process and have the opportunity to comment on all the reports to be submitted to this Department.

You are required to submit the final site layout plan together with the Final EIR to the Department. All available biodiversity information must be used in the finalisation of the layout plan.

The Environmental Management Programme (EMPr) submitted as part of the application for environmental authorisation must include the following:

- All recommendations and mitigation measures to be recorded in the Final EIR.
- A plant rescue and protection plan which allows for the maximum transplant of conservation important species from areas to be transformed. This plan must be compiled by a vegetation specialist familiar with the site in consultation with the ECO and be implemented prior to commencement of the construction phase.
- An open space management plan to be implemented during the construction and operation of the facility.
- A re-vegetation and habitat rehabilitation plan to be implemented during the construction and operation of the facility including timeframes for restoration which must indicate rehabilitation within the shortest possible time after completion of construction activities to reduce the amount of habitat converted at any one time and to speed up the recovery to natural habitats.

- An alien invasive management plan to be implemented during construction and operation of the facility. The plan must include mitigation measures to reduce the invasion of alien species and ensure that the continuous monitoring and removal of alien species is undertaken.
- A storm water management plan to be implemented during the construction and operation of the facility. The plan must ensure compliance with applicable regulations and prevent off-site migration of contaminated storm water or increased soil erosion. The plan must include the construction of appropriate design measures that allow surface and subsurface movement of water along drainage lines so as not to impede natural surface and subsurface flows. Drainage measures must promote the dissipation of storm water run-off.
- An effective monitoring system to detect any leakage or spillage of all hazardous substances during their transportation, handling, use and storage. This must include precautionary measures to limit the possibility of oil and other toxic liquids from entering the soil or storm water systems.
- An erosion management plan for monitoring and rehabilitating erosion events associated with the facility. Appropriate erosion mitigation must form part of this plan to prevent and reduce the risk of any potential erosion.
- A traffic management plan for the site access roads to ensure that no hazards would result from the increased truck traffic and that traffic flow would not be adversely impacted. This plan must include measures to minimize impacts on local commuters e.g. limiting construction vehicles travelling on public roadways during the morning and late afternoon commute time and avoid using roads through densely populated built-up areas so as not to disturb existing retail and commercial operations.
- An environmental sensitivity map indicating environmental sensitive areas and features identified during the EIA process.
- Measures to protect hydrological features such as streams, rivers, pans, wetlands, dams and their catchments, and other environmental sensitive areas from construction impacts including the direct or indirect spillage of pollutants.

You are requested to submit two (2) electronic copies (the main report must be separated from the Appendices (each appendix saved separately) (CD/DVD) and two (2) hard copies of both the Draft and Final Report to the Department. The hard copies must be double-sided printed; and must be ring binded.

The EAP must, in order to give effect to regulation 56 (2), before submitting the Environmental Impact Assessment Report to the Department give registered interested and affected parties access to, and an opportunity to comment on the report in writing.

In terms of regulation 67 of the EIA Regulations, 2010 this application will lapse if the applicant (or the EAP on behalf of the applicant) fails to comply with a requirement in terms of the Regulations for a period of six months after having submitted the application, unless the reasons for failure have been communicated to and accepted by this Department.

You are hereby reminded of Section 24F of the National Environmental Management Act, Act No 107 of 1998, as amended, that no activity may commence prior to an environmental authorisation being granted by the Department.

Yours sincerely



Mr Ishaam Abader

**Deputy Director-General: Legal, Authorisation, Compliance and Enforcement
Department of Environmental Affairs:**

Letter signed by: Ms Mmatlala Rabothata

Designation: Environmental Officer: Integrated Environmental Authorisations

Date: 05/01/2015

CC:	Jasandra Nyker	BioTherm Energy (Pty) Ltd	Fax: 011 367 4601	Email: eiaadmin@biothermenergy.com
	Thulani Mthombeni	Northern Cape Department of Environment and Nature Conservation	Fax: 053 831 3530	Email: tmtho@webmail.co.za
	Mr JRM Alexander	Siyathemba Local Municipality	Fax: N/A	Email: mm@siyathemba.gov.za

A. EIA INFORMATION REQUIRED FOR SOLAR ENERGY FACILITIES

1. General site information

The following general site information is required:

- Descriptions of all affected farm portions
- 21 digit Surveyor General codes of all affected farm portions
- Copies of deeds of all affected farm portions
- Photos of areas that give a visual perspective of all parts of the site
- Photographs from sensitive visual receptors (tourism routes, tourism facilities, etc.)
- Solar plant design specifications including:
 - Type of technology
 - Structure height
 - Surface area to be covered (including associated infrastructure such as roads)
 - Structure orientation
 - Laydown area dimensions (construction period and thereafter)
 - Generation capacity
- Generation capacity of the facility as a whole at delivery points

This information must be indicated on the first page of any Scoping or EIA document. It is also advised that it be double checked as there are too many mistakes in the applications that have been received that take too much time from authorities to correct.

2. Site maps and GIS information

Site maps and GIS information should include at least the following:

- All maps/information layers must also be provided in ESRI Shapefile format
- All affected farm portions must be indicated
- The exact site of the application must be indicated (the areas that will be occupied by the application)
- A status quo map/layer must be provided that includes the following:
 - Current use of land on the site including:
 - Buildings and other structures
 - Agricultural fields

- Grazing areas
 - Natural vegetation areas (natural veld not cultivated for the preceding 10 years) with an indication of the vegetation quality as well as fine scale mapping in respect of Critical Biodiversity Areas and Ecological Support Areas
 - Critically endangered and endangered vegetation areas that occur on the site
 - Bare areas which may be susceptible to soil erosion
 - Cultural historical sites and elements
- Rivers, streams and water courses
- Ridgelines and 20m continuous contours with height references in the GIS database
- Fountains, boreholes, dams (in-stream as well as off-stream) and reservoirs
- High potential agricultural areas as defined by the Department of Agriculture, Forestry and Fisheries
- Buffer zones (also where it is dictated by elements outside the site):
 - 500m from any irrigated agricultural land
 - 1km from residential areas
- Indicate isolated residential, tourism facilities on or within 1km of the site
- A slope analysis map/layer that include the following slope ranges:
 - Less than 8% slope
 - between 8% and 12% slope
 - between 12% and 14% slope
 - steeper than 18 % slope
- A map/layer that indicate locations of birds and bats including roosting and foraging areas (specialist input required)
- A site development proposal map(s)/layer(s) that indicate:
 - Positions of solar facilities
 - Foundation footprint
 - Permanent laydown area footprint
 - Construction period laydown footprint
 - Internal roads indicating width (construction period width and operation period width) and with numbered sections between the other site elements which they serve (to make commenting on sections possible)
 - River, stream and water crossing of roads and cables indicating the type of bridging structures that will be used

- Substation(s) and/or transformer(s) sites including their entire footprint.
- Cable routes and trench dimensions (where they are not along internal roads)
- Connection routes to the distribution/transmission network (the connection must form part of the EIA even if the construction and maintenance thereof will be done by another entity such as Eskom)
- Cut and fill areas along roads and at substation/transformer sites indicating the expected volume of each cut and fill
- Borrow pits
- Spoil heaps (temporary for topsoil and subsoil and permanently for excess material)
- Buildings including accommodation

With the above information authorities will be able to assess the strategic and site impacts of applications.

3. Regional map and GIS information

The regional map and GIS information should include at least the following:

- All maps/information layers must also be provided in ESRI Shapefile format
- The map/layer must cover an area of 20km around the site
- Indicate the following:
 - roads including their types (tarred or gravel) and category (national, provincial, local or private)
 - Railway lines and stations
 - Industrial areas
 - Harbours and airports
 - Electricity transmission and distribution lines and substations
 - Pipelines
 - Water sources to be utilised during the construction and operational phases
 - A visibility assessment of the areas from where the facility will be visible
 - Critical Biodiversity Areas and Ecological Support Areas
 - Critically Endangered and Endangered vegetation areas
 - Agricultural fields
 - Irrigated areas

- An indication of new road or changes and upgrades that must be done to existing roads in order to get equipment onto the site including cut and fill areas and crossings of rivers and streams

4. Important stakeholders

Amongst other important stakeholders, comments from the National Department of Agriculture, Forestry and Fisheries must be obtained and submitted to the Department. Request for comment must be submitted to:

Mrs. Anneliza Collett
Directorate: Land Use & Soil Management
Department of Agriculture, Forestry & Fisheries
Tel: 012 - 319 7508
Fax: 012 - 329 5938
e-mail: AnnelizaC@nda.agric.za
www.agis.agric.za

In addition, comments must be requested from Eskom (Mr Kevin Leask or Mr Ronald Marais (011) 8008111) regarding grid connectivity and capacity.

B. AGRICULTURE STUDY REQUIREMENTS

- Detailed soil assessment of the site in question, incorporating a radius of 50 m surrounding the site, on a scale of 1:10 000 or finer. The soil assessment should include the following:
 - Identification of the soil forms present on site
 - The size of the area where a particular soil form is found
 - GPS readings of soil survey points
 - The depth of the soil at each survey point
 - Soil colour
 - Limiting factors
 - Clay content
 - Slope of the site
 - A detailed map indicating the locality of the soil forms within the specified area,
 - Size of the site
- Exact locality of the site
- Current activities on the site, developments, buildings
- Surrounding developments / land uses and activities in a radius of 500 m of the site

- Access routes and the condition thereof
- Current status of the land (including erosion, vegetation and a degradation assessment)
- Possible land use options for the site
- Water availability, source and quality (if available)
- Detailed descriptions of why agriculture should or should not be the land use of choice
- Impact of the change of land use on the surrounding area
- A shape file containing the soil forms and relevant attribute data as depicted on the map

Department of Environmental Affairs
Environment House
473 Steve Biko Road, Arcadia
PRETORIA
0001

DEA Reference: 14/12/16/3/3/2/766
Our reference: 13031
Date: 27 May 2015

ATTENTION: MMATLALA RABOTHATA

Dear Ms Mmatlala Rabothata

ENVIRONMENTAL IMPACT ASSESSMENT (EIA) FOR THE PROPOSED CONSTRUCTION OF THE HELENA 2 PHOTOVOLTAIC (PV) ENERGY FACILITY NEAR COPPERTON, NORTHERN CAPE PROVINCE

- **DEA Ref No: 14/12/16/3/3/2/766**

Please find herewith two (2) electronic copies (on CD) and two (2) hard copies of the Draft Scoping Report (DSR) for the proposed construction of the Helena 2 Solar Photovoltaic (PV) Energy Facility near Copperton, Northern Cape Province.

Please do not hesitate to contact us should you have any queries in this regard.

Andrea Gibb
PO BOX 2921, Rivonia, 2128
Tel – (011) 798 0600
Fax – (011) 803 7272
Email – andreag@sivest.co.za

Yours sincerely,

A handwritten signature in black ink, appearing to read "Andrea Gibb".

Andrea Gibb
Environmental Consultant
SIVEST Environmental Division

Encl: 2 x Hard copies of the DSR (Incl. Appendices)
2 x Electronic copies (on CD) of the DSR (Incl. Appendices)



environmental affairs

Department:
Environmental Affairs
REPUBLIC OF SOUTH AFRICA

Private Bag X 447 · PRETORIA · 0001 · Environmental House · 473 Steve Biko Road · PRETORIA
Tel (+ 27 12) 399 9972

DEA Reference: 14/12/16/3/3/2/766

Enquiries: Ms Mmatlala Rabothata

Tel: 012 399 9372 **E-mail:** mrabothata@environment.gov.za

Ms Andrea Gibb
SiVEST SA (Pty) Ltd
PO Box 2921
RIVONIA
2128

Telephone Number: 011 798 0638

Email: andreag@sivest.co.za

PER EMAIL / MAIL

Dear Ms Gibb

ACKNOWLEDGEMENT OF RECEIPT OF DRAFT SCOPING REPORT FOR THE PROPOSED HELENA SOLAR 2, 75MW SOLAR PHOTOVOLTAIC (PV) ENERGY FACILITY NEAR COPPERTON WITHIN SIYATHEMBA LOCAL MUNICIPALITY IN NORTHERN CAPE PROVINCE

The Department confirms having received the draft Scoping Report for the above-mentioned project on 28 May 2015.

Please note that the Department will start reviewing once the final Scoping Report is received.

You are hereby reminded that the activity may not commence prior to an environmental authorisation being granted by the Department.

Yours sincerely

Mr Sabelo Malaza

Chief Director: Integrated Environmental Authorisations

Department of Environmental Affairs

Letter signed by: Ms Mmatlala Rabothata

Designation: Environmental Officer: Integrated Environmental Authorisations

Date: 11/06/2015

Department of Environmental Affairs
Environment House
473 Steve Biko Road, Arcadia
PRETORIA
0001

DEA Reference: 14/12/16/3/3/2/766
Our reference: 13031
Date: 17 August 2015

ATTENTION: MMATLALA RABOTHATA

Dear Ms Mmatlala Rabothata

ENVIRONMENTAL IMPACT ASSESSMENT (EIA) FOR THE PROPOSED CONSTRUCTION OF THE HELENA 2 PHOTOVOLTAIC (PV) ENERGY FACILITY NEAR COPPERTON, NORTHERN CAPE PROVINCE

- **DEA Ref No: 14/12/16/3/3/2/766**

Please find herewith two (2) electronic copies (on CD) and two (2) hard copies of the Final Scoping Report (FSR) for the proposed construction of the Helena 2 Solar Photovoltaic (PV) Energy Facility near Copperton, Northern Cape Province.

Please do not hesitate to contact us should you have any queries in this regard.

Andrea Gibb
PO BOX 2921, Rivonia, 2128
Tel – (011) 798 0600
Fax – (011) 803 7272
Email – andreag@sivest.co.za

Yours sincerely,

A handwritten signature in black ink, appearing to read "Andrea Gibb".

Andrea Gibb
Environmental Consultant
SIVEST Environmental Division

Encl: 2 x Hard copies of the FSR (Incl. Appendices)
2 x Electronic copies (on CD) of the FSR (Incl. Appendices)



environmental affairs

Department:
Environmental Affairs
REPUBLIC OF SOUTH AFRICA

Private Bag X 447 · PRETORIA · 0001 · Environmental House · 473 Steve Biko Road · PRETORIA
Tel (+ 27 12) 399 9972

DEA Reference: 14/12/16/3/3/2/766
Enquiries: Mr Muhammad Essop
Tel: 012 399 9406 E-mails: MEssop@environment.gov.za

Andrea Gibb
Sivest Environmental
PO Box 2921
RIVONIA
2128

Fax: 011 798 0600
Tel: 011 803 7272
Email: andreag@sivest.co.za

PER EMAIL / MAIL

Dear Sir/Madam

ACKNOWLEDGEMENT OF RECEIPT OF THE FINAL SCOPING REPORT FOR PROPOSED CONSTRUCTION OF THE HELENA 2 PHOTOVOLTAIC PV ENERGY FACILITY NEAR COPPERTON, NORTHERN CAPE PROVINCE.

The Department confirms having received the final Scoping Report dated 17 August 2015 for the above-mentioned project on 18 August 2015.

You are hereby reminded that the activity may not commence prior to an environmental authorisation being granted by the Department.

Yours sincerely

Soobramany

Mr Sabelo Malaza

Chief Director: Integrated Environmental Authorisations

Department of Environmental Affairs:

Letter signed by: Ms Senisha Soobramany

Designation: Control Environmental Officer (Grade A): Coordination and Strategic Planning and Support

Date: 31 August 2015



environmental affairs

Department:
Environmental Affairs
REPUBLIC OF SOUTH AFRICA

Private Bag X 447 · PRETORIA · 0001 · Environment House · 473 Steve Biko Road · Arcadia · PRETORIA
Tel (+ 27 12) 399 9372

DEA Reference: 14/12/16/3/3/2/766

Enquiries: Mr Herman Alberts

Telephone: (012) 399 9371 E-mail: HAlberts@environment.gov.za

Ms Andrea Gibb
SiVEST Environmental Division
PO Box 2921
RIVONIA
2128

Telephone Number: (011) 798 0600
Email Address: andreag@sivest.co.za

PER EMAIL / MAIL

Dear Ms Gibb

ACCEPTANCE OF THE SCOPING REPORT FOR THE PROPOSED CONSTRUCTION OF THE HELENA 2 PHOTOVOLTAIC (PV) ENERGY FACILITY NEAR COPPERTON WITHIN THE SIYATHEMBA LOCAL MUNICIPALITY, NORTHERN CAPE PROVINCE

The Scoping Report (SR) and Plan of Study for Environmental Impact Assessment (PoSEIA) dated 17 August 2015 and received by this Department on 18 August 2015 refer.

This Department has evaluated the submitted SR and the PoSEIA dated 17 August 2015 and is satisfied that the documents comply with the minimum requirements of the Environmental Impact Assessment (EIA) Regulations, 2010. The SR is hereby accepted by the Department in terms of Regulation 30(1)(a) of the EIA Regulations, 2010.

You may proceed with the Environmental Impact Assessment process in accordance with the tasks contemplated in the PoSEIA and the requirements of the EIA Regulations, 2010.

All comments and recommendations made by all stakeholders and Interested and Affected Parties (I&APs) in the draft SR and submitted as part of the SR must be taken into consideration when preparing an Environmental Impact Assessment report (EIAR) in respect of the proposed development. Please ensure that all mitigation measures and recommendations in the specialist studies are addressed and included in the final EIAR and Environmental Management Programme (EMPr).

Please ensure that comments from all relevant stakeholders are submitted to the Department with the final EIAR. This includes but is not limited to the Northern Cape Department of Environmental Affairs and Nature Conservation, the Department of Agriculture, Forestry and Fisheries (DAFF), the provincial Department of Agriculture, the South African Civil Aviation Authority (SACAA), the Department of Transport, the Siyathemba Local Municipality, the District Municipality, the Department of Water and Sanitation (DWS), the Department of Communications, SENTECH, Eskom Holdings SOC Limited, the South African National Roads Agency Limited (SANRAL), the South African Heritage Resources Agency (SAHRA), EWT, BirdLife SA, the Department of Mineral Resources, the Department of Rural Development and Land Reform, the Department of Environmental Affairs: Directorate Biodiversity and Conservation and the Square Kilometre Array (SKA).

Please be advised that the contact person for renewable projects at the SKA office is Dr Adrian Tiplady and he can be contacted on Tel: (011) 442 2434 or E-mail: atiplady@ska.ac.za.

You are also required to address all issues raised by Organs of State and I&APs prior to the submission of the EIAr to the Department.

Proof of correspondence with the various stakeholders must be included in the EIAr. Should you be unable to obtain comments, proof should be submitted to the Department of the attempts that were made to obtain comments.

The EAP must, in order to give effect to Regulation 56(2), give registered I&APs access to, and an opportunity to comment on the report in writing within 21 days before submitting the final EIAr to the Department.

In addition, the following additional information is required for the EIAr:

- i. Following a review of the SR and application form, the following information must form part of the EIAr as well as a separate document for ease of reference:
 - An amended application form with an indication of all the 2010 listed activities that are still listed;
 - An indication of all the similarly listed 2014 activities;
 - An indication if there are any new 2014 activities that are listed;
 - An indication where in the report all the 2014 activities have been assessed and mitigated for; and,
 - A letter/affidavit from the EAP indicating that the above is true and correct.
- ii. Please note that the Department's application form template has been amended and can be downloaded from the following link <https://www.environment.gov.za/documents/forms>.
- iii. It is imperative that the relevant authorities are continuously involved throughout the EIAr process as the development property possibly falls within geographically designated areas in terms of GN R. 546 Activity 4; 12; 13; 14; 16; and, 19.
- iv. In addition, a graphical representation of the proposed development within the respective geographical areas must be provided.
- v. The EAP must provide motivation for the applicability for Item 26 of GNR 544. In addition the list gazetted under Section 53(1) of NEMBA must be provided in the EIAr.
- vi. The EAP must chose the correct sub item as described in Item 22 and 39 of GNR 544 and adequately assess the impacts in the EIAr.
- vii. The EIAr must provide an assessment of the impacts and mitigation measures for each of the listed activities applied for.
- viii. Cumulative impacts of similar type of developments in the area must form part of the studies that must be assessed as part of the EIA process.
- ix. The following activities applied for may trigger Section 19 and Section 21 of the National Water Act No. 36 of 1998: GN R. 544 Activities 11(xi) and 18(i). The EAP is advised to conduct a surface hydrological study as part of the EIAr. The terms of reference for the study must include, inter alia the following:
 - Identification and sensitivity rating of all surface water courses for the impact phase of the proposed development;
 - Identification, assessment of all potential impacts to the water courses and suggestion of mitigation measures; and,
 - Recommendations on the preferred placement of photovoltaic panels and associated infrastructure.
- x. The listed activities represented in the EIAr and the application form must be the same and correct.
- xi. The EIAr must provide the technical details for the proposed facility in a table format as well as their description and/or dimensions. A sample for the minimum information required is listed under point 2 of the EIA information required for solar energy facilities below.

- xii. The EIA must provide the four corner coordinate points for the proposed development site (note that if the site has numerous bend points, at each bend point coordinates must be provided) as well as the start, middle and end point of all linear activities.
- xiii. The EIA must provide the following:
- Clear indication of the envisioned area for the proposed solar energy facility; i.e. placing of photovoltaic panels and all associated infrastructure should be mapped at an appropriate scale.
 - Clear description of all associated infrastructure. This description must include, but is not limited to the following:
 - Power lines;
 - Internal roads infrastructure; and;
 - All supporting onsite infrastructure such as laydown area, guard house and control room etc.
 - All necessary details regarding all possible locations and sizes of the proposed satellite substation and the main substation.
- xiv. The EIA must also include a comments and response report in accordance with Regulation 28(m) of the EIA Regulations, 2010.
- xv. The EIA must include the detail inclusive of the PPP in accordance with Regulation 54 of the EIA Regulation.
- xvi. Details of the future plans for the site and infrastructure after decommissioning in 20-30 years and the possibility of upgrading the proposed infrastructure to more advanced technologies.
- xvii. An Avifaunal Assessment must be conducted to determine the impacts that the proposed activity (including the powerline) may have on avifauna. Mitigation measures must be proposed and included in the EIA and the EMP.
- xviii. Engagement with the SKA must take place due to the proximity of the facility to the SKA infrastructure. The EMI and RFI study must look at cumulative impacts as well.
- xix. Information on services required on the site, e.g. sewage, refuse removal, water and electricity. Who will supply these services and has an agreement and confirmation of capacity been obtained? Proof of these agreements must be provided.
- xx. The EIA must provide a detailed description of the need and desirability, not only providing motivation on the need for clean energy in South Africa of the proposed activity. The need and desirability must also indicate if the proposed development is needed in the region and if the current proposed location is desirable for the proposed activity compared to other sites.
- xxi. A copy of the final site layout map. All available biodiversity information must be used in the finalisation of the layout map. Existing infrastructure must be used as far as possible e.g. roads. The layout map must indicate the following:
- PV positions and its associated infrastructure;
 - Permanent laydown area footprint;
 - Internal roads indicating width (construction period width and operation period width) and with numbered sections between the other site elements which they serve (to make commenting on sections possible);
 - Wetlands, drainage lines, rivers, stream and water crossing of roads and cables indicating the type of bridging structures that will be used;
 - The location of sensitive environmental features on site e.g. CBAs, heritage sites, wetlands, drainage lines etc. that will be affected by the facility and its associated infrastructure;
 - Substation(s) and/or transformer(s) sites including their entire footprint;
 - Connection routes (including pylon positions) to the distribution/transmission network;
 - All existing infrastructure on the site, especially roads;
 - Buffer areas;
 - Buildings, including accommodation; and
 - All "no-go" areas.

- xxii. An environmental sensitivity map indicating environmental sensitive areas and features identified during the EIA process.
- xxiii. A map combining the final layout map superimposed (overlain) on the environmental sensitivity map.
- xxiv. A shapefile of the preferred development layout/footprint must be submitted to this Department. The shapefile must be created using the Hartebeesthoek 94 Datum and the data should be in Decimal Degree Format using the WGS 84 Spheroid. The shapefile must include at a minimum the following extensions i.e. .shp; .shx; .dbf; .prj; and, .xml (Metadata file). If specific symbology was assigned to the file, then the .avl and/or the .lyr file must also be included. Data must be mapped at a scale of 1:10 000 (please specify if an alternative scale was used). The metadata must include a description of the base data used for digitizing. The shapefile must be submitted in a zip file using the EIA application reference number as the title. The shape file must be submitted to:

Postal Address:

Department of Environmental Affairs
Private Bag X447
Pretoria
0001

Physical address:

Environment House
473 Steve Biko Road
Pretoria

For Attention: Muhammad Essop
Integrated Environmental Authorisations
Strategic Infrastructure Developments
Telephone Number: (012) 399 9406
Email Address: MEssop@environment.gov.za

The Environmental Management Programme (EMPr) to be submitted as part of the EIAR must include the following:

- i. All recommendations and mitigation measures recorded in the EIAR and the specialist studies conducted.
- ii. The final site layout map.
- iii. Measures as dictated by the final site layout map and micro-siting.
- iv. An environmental sensitivity map indicating environmental sensitive areas and features identified during the EIA process.
- v. A map combining the final layout map superimposed (overlain) on the environmental sensitivity map.
- vi. An alien invasive management plan to be implemented during construction and operation of the facility. The plan must include mitigation measures to reduce the invasion of alien species and ensure that the continuous monitoring and removal of alien species is undertaken.
- vii. A plant rescue and protection plan which allows for the maximum transplant of conservation important species from areas to be transformed. This plan must be compiled by a vegetation specialist familiar with the site and be implemented prior to commencement of the construction phase.
- viii. A re-vegetation and habitat rehabilitation plan to be implemented during the construction and operation of the facility. Restoration must be undertaken as soon as possible after completion of construction activities to reduce the amount of habitat converted at any one time and to speed up the recovery to natural habitats.
- ix. An open space management plan to be implemented during the construction and operation of the facility.

- x. A traffic management plan for the site access roads to ensure that no hazards would result from the increased truck traffic and that traffic flow would not be adversely impacted. This plan must include measures to minimize impacts on local commuters e.g. limiting construction vehicles travelling on public roadways during the morning and late afternoon commute time and avoid using roads through densely populated built-up areas so as not to disturb existing retail and commercial operations.
- xi. A transportation plan for the transport of components, main assembly cranes and other large pieces of equipment.
- xii. A storm water management plan to be implemented during the construction and operation of the facility. The plan must ensure compliance with applicable regulations and prevent off-site migration of contaminated storm water or increased soil erosion. The plan must include the construction of appropriate design measures that allow surface and subsurface movement of water along drainage lines so as not to impede natural surface and subsurface flows. Drainage measures must promote the dissipation of storm water run-off.
- xiii. A fire management plan to be implemented during the construction and operation of the facility.
- xiv. An erosion management plan for monitoring and rehabilitating erosion events associated with the facility. Appropriate erosion mitigation must form part of this plan to prevent and reduce the risk of any potential erosion.
- xv. An effective monitoring system to detect any leakage or spillage of all hazardous substances during their transportation, handling, use and storage. This must include precautionary measures to limit the possibility of oil and other toxic liquids from entering the soil or storm water systems.
- xvi. Measures to protect hydrological features such as streams, rivers, pans, wetlands, dams and their catchments, and other environmental sensitive areas from construction impacts including the direct or indirect spillage of pollutants.

The EAP must provide detailed motivation if any of the above requirements is not required by the proposed development and not included in the EMPr.

The EIAr must include a **cumulative impact assessment** of the facility if there are other similar facilities in the region. The specialist studies e.g. biodiversity, visual, noise etc. must also assess the facility in terms of potential cumulative impacts. The specialist studies as outlined in the PoSEIA which is incorporated as part of the SR must also assess the facility in terms of potential cumulative impacts.

Please ensure that all the relevant Listing Notice activities are applied for, that the Listing Notice activities applied for are specific and that they can be linked to the development activity or infrastructure in the project description.

You are hereby reminded that should the EIAr fail to comply with the requirements of this acceptance letter, the EIAr will be rejected.

The applicant is hereby reminded to comply with the requirements of Regulation 67 with regard to the time period allowed for complying with the requirements of the Regulations, and Regulations 56 and 57 with regard to the allowance of a comment period for interested and affected parties on all reports submitted to the competent authority for decision-making. The reports referred to are listed in Regulation 56(3a-3h).

Furthermore, it must be reiterated that, should an application for Environmental Authorisation be subject to the provisions of Chapter II, Section 38 of the National Heritage Resources Act, Act 25 of 1999, then this Department will not be able to make nor issue a decision in terms of your application for Environmental Authorisation pending a letter from the pertinent heritage authority categorically stating that the application fulfils the requirements of the relevant heritage resources authority as described in Chapter II, Section 38(8)

of the National Heritage Resources Act, Act 25 of 1999. Comments from SAHRA and/or the provincial department of heritage must be provided in the EIAr.

You are requested to submit two (2) electronic copies (CD/DVD and two (2) hard copies of the EIAr to the Department as per Regulation 34(1) (b) of the EIA Regulations, 2010.

Please also find attached information that must be used in the preparation of the EIAr. This will enable the Department to speedily review the EIAr and make a decision on the application.

You are hereby reminded of Section 24F of the National Environmental Management Act, Act No. 107 of 1998, as amended, which stipulates that no activity may commence prior to an Environmental Authorisation being granted by the Department.

Yours faithfully



Mr Sabelo Malaza

Chief Director: Integrated Environmental Authorisations

Department of Environmental Affairs

Letter Signed by: Mr Coenrad Agenbach

Designation: Deputy Director: Strategic Infrastructure Developments

Date: 20/10/2015

cc:	Jasandra Nyker	BioTherm Energy (Pty) Ltd	E-mail: eiaadmin@biothermenergy.com
	Thulani Mthombeni	NC DENC	E-mail: tmtho@webmail.co.za
	JRM Alexander	Siyathemba Local Municipality	E-mail: mm@siyathemba.gov.za

A. EIA INFORMATION REQUIRED FOR SOLAR ENERGY FACILITIES

1. General site information

The following general site information is required:

- Descriptions of all affected farm portions
- 21 digit Surveyor General codes of all affected farm portions
- Copies of deeds of all affected farm portions
- Photos of areas that give a visual perspective of all parts of the site
- Photographs from sensitive visual receptors (tourism routes, tourism facilities, etc.)
- Solar plant design specifications including:
 - Type of technology
 - Structure height
 - Surface area to be covered (including associated infrastructure such as roads)
 - Structure orientation
 - Laydown area dimensions (construction period and thereafter)
 - Generation capacity
- Generation capacity of the facility as a whole at delivery points

This information must be indicated on the first page of the EIAr. It is also advised that it be double checked as there are too many mistakes in the applications that have been received that take too much time from authorities to correct.

2. Sample of technical details for the proposed facility

Component	Description / dimensions
Height of PV panels	
Area of PV Array	
Number of inverters required	
Area occupied by inverter / transformer stations / substations	
Capacity of on-site substation	
Area occupied by both permanent and construction laydown areas	
Area occupied by buildings	
Length of internal roads	
Width of internal roads	
Proximity to grid connection	
Height of fencing	
Type of fencing	

3. Site maps and GIS information

Site maps and GIS information should include at least the following:

- All maps/information layers must also be provided in ESRI Shapefile format
- All affected farm portions must be indicated
- The exact site of the application must be indicated (the areas that will be occupied by the application)

- A status quo map/layer must be provided that includes the following:
 - Current use of land on the site including:
 - Buildings and other structures
 - Agricultural fields
 - Grazing areas
 - Natural vegetation areas (natural veld not cultivated for the preceding 10 years) with an indication of the vegetation quality as well as fine scale mapping in respect of Critical Biodiversity Areas and Ecological Support Areas
 - Critically endangered and endangered vegetation areas that occur on the site
 - Bare areas which may be susceptible to soil erosion
 - Cultural historical sites and elements
 - Rivers, streams and water courses
 - Ridgelines and 20m continuous contours with height references in the GIS database
 - Fountains, boreholes, dams (in-stream as well as off-stream) and reservoirs
 - High potential agricultural areas as defined by the Department of Agriculture, Forestry and Fisheries
 - Buffer zones (also where it is dictated by elements outside the site):
 - 500m from any irrigated agricultural land
 - 1km from residential areas
 - Indicate isolated residential, tourism facilities on or within 1km of the site
- A slope analysis map/layer that include the following slope ranges:
 - Less than 8% slope (preferred areas for PV and infrastructure)
 - between 8% and 12% slope (potentially sensitive to PV and infrastructure)
 - between 12% and 14% slope (highly sensitive to PV and infrastructure)
 - steeper than 18 % slope (unsuitable for PV and infrastructure)
- A site development proposal map(s)/layer(s) that indicate:
 - Foundation footprint
 - Permanent laydown area footprint
 - Construction period laydown footprint
 - Internal roads indicating width (construction period width and operation period width) and with numbered sections between the other site elements which they serve (to make commenting on sections possible)
 - River, stream and water crossing of roads and cables indicating the type of bridging structures that will be used
 - Substation(s) and/or transformer(s) sites including their entire footprint.
 - Cable routes and trench dimensions (where they are not along internal roads)
 - Connection routes to the distribution/transmission network (the connection must form part of the EIA even if the construction and maintenance thereof will be done by another entity such as ESKOM)
 - Cut and fill areas at PV sites along roads and at substation/transformer sites indicating the expected volume of each cut and fill
 - Borrow pits
 - Spoil heaps (temporary for topsoil and subsoil and permanently for excess material)
 - Buildings including accommodation

With the above information authorities will be able to assess the strategic and site impacts of the application.

4. Regional map and GIS information

The regional map and GIS information should include at least the following:

- All maps/information layers must also be provided in ESRI Shapefile format
- The map/layer must cover an area of 20km around the site
- Indicate the following:
 - roads including their types (tarred or gravel) and category (national, provincial, local or private)
 - Railway lines and stations
 - Industrial areas
 - Harbours and airports
 - Electricity transmission and distribution lines and substations
 - Pipelines
 - Waters sources to be utilised during the construction and operational phases
 - A visibility assessment of the areas from where the facility will be visible
 - Critical Biodiversity Areas and Ecological Support Areas
 - Critically Endangered and Endangered vegetation areas
 - Agricultural fields
 - Irrigated areas
 - An indication of new road or changes and upgrades that must be done to existing roads in order to get equipment onto the site including cut and fill areas and crossings of rivers and streams

5. Important stakeholders

Amongst other important stakeholders, comments from the National Department of Agriculture, Forestry and Fisheries must be obtained and submitted to the Department. Any application, documentation, notification etc. should be forwarded to the following officials:

Ms Mashudu Marubini
Delegate of the Minister (Act 70 of 1970)
E-mail: MashuduMa@daff.gov.za
Tel 012- 319 7619

Ms Thoko Buthelezi
AgriLand Liaison office
E-mail: ThokoB@daff.gov.za
Tel 012- 319 7634

All hardcopy applications / documentation should be forwarded to the following address:

Physical address:

Delpen Building
Cnr Annie Botha and Union Street
Office 270
Attention: Delegate of the Minister Act 70 of 1970

Postal Address:

Department of Agriculture, Forestry and Fisheries
Private Bag X120
Pretoria

0001

Attention: Delegate of the Minister Act 70 of 1970

In addition, comments must be requested from Eskom regarding grid connectivity and capacity. Request for comment must be submitted to:

Mr John Geeringh
Eskom Transmission
Megawatt Park D1Y38
PO Box 1091
JOHANNESBURG
2000

Tel: 011 516 7233

Fax: 086 661 4064

John.geeringh@eskom.co.za

B. AGRICULTURE STUDY REQUIREMENTS

- Detailed soil assessment of the site in question, incorporating a radius of 50 m surrounding the site, on a scale of 1:10 000 or finer. The soil assessment should include the following:
 - Identification of the soil forms present on site
 - The size of the area where a particular soil form is found
 - GPS readings of soil survey points
 - The depth of the soil at each survey point
 - Soil colour
 - Limiting factors
 - Clay content
 - Slope of the site
 - A detailed map indicating the locality of the soil forms within the specified area,
 - Size of the site
- Exact locality of the site
- Current activities on the site, developments, buildings
- Surrounding developments / land uses and activities in a radius of 500 m of the site
- Access routes and the condition thereof
- Current status of the land (including erosion, vegetation and a degradation assessment)
- Possible land use options for the site
- Water availability, source and quality (if available)
- Detailed descriptions of why agriculture should or should not be the land use of choice
- Impact of the change of land use on the surrounding area
- A shape file containing the soil forms and relevant attribute data as depicted on the map.

C. ASTRONOMY GEOGRAPHIC ADVANTAGE ACT, 2007 (ACT NO. 21 OF 2007)

The purpose of the Act is to preserve the geographic advantage areas that attract investment in astronomy. The entire Northern Cape Province excluding the Sol Plaatjie Municipality had been declared an astronomy advantage area. The Northern Cape optical and radio telescope sites were declared core astronomy advantage areas. The Act allowed for the declaration of the Southern Africa Large Telescope (SALT), MeerKAT and Square Kilometre Array (SKA) as astronomy and related scientific endeavours that had to be protected.

You are requested to indicate the applicability of the Astronomy Geographic Advantage Act, Act No. 21 of 2007 on the application in the BAR/EIR. You must obtain comments from the Southern African Large Telescope (SALT) if the proposed development is situated within a declared astronomy advantage area.



environmental affairs

Department:
Environmental Affairs
REPUBLIC OF SOUTH AFRICA

Private Bag X 447 · PRETORIA · 0001 · Environmental House · 473 Steve Biko Road · PRETORIA
Tel (+ 27 12) 399 9972

DEA Reference: 14/12/16/3/3/2/766
Enquiries: Mr Herman Alberts
Tel: 012 399 9371 E-mail: HALberts@environment.gov.za

Andrea Gibb
SiVEST Environmental Division
P.O. Box 2921
RIVONIA
2128

Tel: 011 798 0600
Email: andreaq@sivest.co.za

PER E-MAIL / MAIL

Dear Sir/Madam

ACKNOWLEDGEMENT OF RECEIPT OF DRAFT ENVIRONMENTAL IMPACT ASSESSMENT REPORT FOR THE PROPOSED CONSTRUCTION OF THE HELENA 2 PV ENERGY FACILITY NEAR COPPERTON, NORTHERN CAPE PROVINCE

The Department confirms having received the draft Environmental Impact Assessment Report for the above-mentioned project on 04 January 2016.

Please note that the Department will start reviewing once the final Environmental Impact Assessment Report is received.

You are hereby reminded that the activity may not commence prior to an environmental authorisation being granted by the Department.

Yours sincerely

Mr Sabelo Malaza

Chief Director: Integrated Environmental Authorisations
Department of Environmental Affairs

Letter signed by: Ms Senisha Soobramany

Designation: Control Environmental Officer (Grade A): Coordination and Strategic Planning and Support

Date: 18 January 2016

Department of Environmental Affairs
Environment House
473 Steve Biko Road, Arcadia
PRETORIA
0001

DEA Reference: 14/12/16/3/3/2/766
Our reference: 13031
Date: 10 June 2016

ATTENTION: HERMAN ALBERTS

Dear Mr Herman Alberts

REQUEST FOR AN EXTENSION: ENVIRONMENTAL IMPACT ASSESSMENT (EIA) FOR THE PROPOSED CONSTRUCTION OF THE HELENA 2 PHOTOVOLTAIC (PV) ENERGY FACILITY NEAR COPPERTON, NORTHERN CAPE PROVINCE

- **DEA Ref No: 14/12/16/3/3/2/766**

This letter refers to the proposed construction of the Helena 2 photovoltaic (PV) energy facility near Copperton, in the Northern Cape Province (hereafter referred to as "the proposed project"). The Draft Environmental Impact Assessment Report (DEIAR) for the proposed project was submitted to the Department of Environmental Affairs (hereafter referred to as the "Department") by SiVEST the Environmental Assessment Practitioner (EAP) in December 2015. The Department confirmed receipt of the DEIAR on 4 January 2016.

Since early 2015 BioTherm Energy (the "Applicant") and SiVEST have been in consultation with the SKA, who have informed the Applicant that the proposed project could pose a high risk to the SKA. The Applicant has been actively engaging with the SKA and has already conducted electromagnetic interference (EMI) studies as requested by the SKA.

The Applicant is requesting an extension in order to comply with the SKA's further requirement that technical proof of concepts would need to be implemented and measured.

A timeline of SKA correspondence and the actions taken by the Applicant is provided below:

- The SKA sent a letter to SiVEST on 23 February 2015 stating that the proposed project could pose a high risk of detrimental impact on the SKA. The SKA advised that detailed EMI studies be conducted in order to scientifically validate the impact of the proposed project on the SKA, and also to identify any possible mitigation measures that could result in the proposed project meeting SKA radio emission protection requirements.
- In March 2015, the Applicant appointed MESA Solutions (Pty) Ltd (hereafter referred to as "MESA") to conduct basic topographical investigations based on the location of proposed project situated in the vicinity of the Karoo Central Astronomy Advantage Areas. MESA provided a report on 21 April 2015.
- The results of the topographical investigation indicated that there is minimal contribution from the terrain loss towards the closest SKA telescope and this is mainly due to the absence of major natural obstructions between the proposed project and the SKA core site.
- The SKA further required that a measurement campaign at a representative operational facility should be carried out, in order to ascertain that the EMI emissions could be attenuated to levels below the SKA minimum acceptable EMI emissions thresholds.
- The Applicant then appointed MESA Solutions to conduct an EMI characteristic study based on an operational 75MW solar energy facility. The study detailed the amount by which, identified EMI emissions exceeded limits.

The study noted that the EMI emissions could be mitigated through Emission Management Control (EMC) shielding cabinets. The study was completed in November 2015.

- Following several meetings between the Applicant and the SKA, a formal submission of the MESA report was made to the SKA on 18 November 2015 for comment.
- The SKA provided comment on 17 December 2015 stating that they are not in support of the project given the current information provided in the MESA report. The SKA further stated that technical proof of concepts would need to be implemented and measured. This would entail taking measurements at an operational facility, a test facility or in a laboratory, where such technical concepts can be installed and measured.
- The Applicant, since then, has contacted various engineering firms and suppliers in South Africa in order to determine if they have worked on projects or with equipment where EMI emissions mitigation measures have been implemented. Unfortunately none of the suppliers have been involved in the implementation of mitigation measures and no such operational projects exist.
- In order to satisfy the additional SKA request, the Applicant is engaging with international PV technology suppliers and EMI consultants to identify possible mitigation measures and test facilities to measure the impact of the mitigation measures. Once a supplier with suitable equipment and a test facility has been identified, MESA will be appointed to assist with the additional measurements and the installation of the proposed mitigation measures.

Based on the above, we hereby request that the Department's file for the above mentioned project be kept open for an extended period to allow the Applicant to conduct the studies requested by the SKA.

SiVEST believes that it is in the best interest of I&APs, that the submission of the Final Environmental Impact Assessment Report (FEIAR) be delayed in order to incorporate the findings of the additional studies requested by the SKA. Further, given the industry interest in the Northern Cape generally, and in regions in close proximity to the proposed SKA sites more specifically, we believe that detailed studies and implementation of the technical concepts would be beneficial to the SKA. The findings from the proposed studies would contribute significantly to an understanding of the impact of solar PV installations on the SKA and thereby benefit two national objectives, namely producing renewable energy and developing one of the biggest-ever multinational scientific collaborations.

It is kindly requested that the Department keep the file open for a minimum of an additional six months to allow the Applicant and MESA to complete the additional studies as requested by the SKA, so as to include these results in the FEIAR and make it available to I&APs before submission to the DEA.

As per Regulation 67 (2) of the NEMA EIA Regulations 2010, we kindly request that the Department notify us of their acceptance of the above as a matter of urgency.

Yours sincerely



Andrea Gibb
Senior Environmental Assessment Practitioner
SiVEST Environmental

Encl: SKA correspondence 23 February 2015
SKA correspondence 17 December 2015

cc. Irene Bezuidenhout – BioTherm Energy



17 Baker Street
Rosebank
Johannesburg
South Africa
2196

Tel: +27 (0) 11 442 2434
Fax: +27 (0) 11 442 2454
Email: atiplady@ska.ac.za

Andrea Gibb
Environmental Practitioner and Visual Specialist
SiVEST Environmental Division
PO Box 2921
Rivonia
2128

E-mail: andrea@sivest.co.za

Date: 23 February 2015

Dear Andrea,

Re: Development of three 75MW Solar PV Energy Facilities (Helena Solar 1-3) near Copperton in the Northern Cape Province.

This letter is in response to your email request, to provide an assessment on the potential development of three 75MW solar electricity generation facilities in the Northern Cape Province and the risk they may pose on the Square Kilometre Array Project.

A high level risk assessment has been conducted at the South African SKA Project Office to determine the potential impact of such facilities on the Square Kilometre Array. This letter serves to confirm the outcomes of the risk assessment, and proposals for any future investigations associated with this facility.

- I. The location of the proposed facility has been provided in the background information document compiled by SiVEST Environmental Division,
- II. The nearest SKA station has been identified SKA-Ant-190, at approximately 23km from the proposed installation at Klipgatspan;
- III. Based on distance to the nearest SKA station, detailed design of the solar installation, and the cumulative impact of multiple renewable energy facilities of a similar nature in the same vicinity, the proposed facilities poses a **high** risk of detrimental impact on the SKA;
- IV. Any transmitters that are to be established, or have been established, at the site for the purposes of voice and data communication will be required to comply with the relevant AGA regulations concerning the restriction of use of the radio frequency spectrum that applies in the area concerned;
- V. As a result of the **high** risk associated with these facilities, The SKA project office recommends that further detailed EMI and RFI detailed studies be conducted as significant mitigation measures would be required to lower the risk of detrimental impact to an acceptable level. It is not guaranteed that sufficient mitigation measures would be available. The South African SKA Project Office would like to



be kept informed of progress with this project, and reserves the right to further risk assessments at a later stage.

This technical advice is provided by the South African SKA Project Office on the basis of the protection requirements of the SKA in South Africa, and does not constitute legal approval of the renewable energy projects in terms of the Astronomy Geographic Advantage Act, the Management Authority, and its regulations or declarations.

Regards,

Dr. Adrian Tiplady
South African SKA Site Bid Manager
SKA South Africa
Tel: 011 442 2434
Fax: 011 442 2454
atiplady@ska.ac.za



17 Baker Street
Rosebank
Johannesburg
South Africa
2196

Tel: +27 (0) 11 442 2434
Fax: +27 (0) 11 442 2454
Email: atiplady@ska.ac.za

Andrea Gibb
Environmental Practitioner and Visual Specialist
SiVEST Environmental Division
PO Box 2921
Rivonia
2128

E-mail: andrea@sivest.co.za

Date: 17 December 2015

Dear Andrea,

**Re: Development of three 75MW Solar PV Energy Facilities (Helena Solar 1-3) near
Copperton in the Northern Cape Province.**

A high level risk assessment was conducted for the above mentioned photovoltaic electricity generation facilities, based on the distance to the nearest SKA station and information available on the detailed design of PV facilities. The result of the initial assessment, which indicated that the proposed facility could pose a medium to high risk of detrimental impact on the SKA telescope, was communicated to SiVest Environmental Division in a letter dated 23 February 2015. In the letter, it was recommended that further detailed electromagnetic interference (EMI) studies be conducted in order to scientifically validate the impact of the proposed PV facilities on the SKA, and also to identify any possible mitigation measures that could result in the facility meeting SKA radio emission protection requirements.

Since February, SKA South Africa has engaged with the developers, BioTherm Energy, on this and other projects. BioTherm appointed MESA Solutions (Pty) Ltd to conduct appropriate EMI studies. The initial results from the topographical technical report produced by MESA Solutions (Pty) Ltd, based on radio propagation simulations, were found to be inconclusive. SKA South Africa requested more detailed studies to be conducted, which would have to include measuring the electromagnetic profile of facilities that use similar technology as the one proposed for Helena PV facilities. These measurements have been conducted, and a report provided to SKA South Africa for review.

The results from both studies conducted by MESA Solutions indicates that the development of these facilities would pose a high risk of detrimental impact on the SKA radio telescope – higher than originally understood. This risk is even higher once consideration is given to the cumulative impact of multiple facilities at, or near, the proposed location. The proposed mitigation measures are untested at the scale of implementation required, and



technical proof of concepts would need to be implemented and measured to prove their efficacy before the identified risk is to be revisited.

If these facilities were to be developed as currently defined, they would pose an unacceptable risk to the SKA, and would not be able to meet SKA radio emission protection requirements as prescribed in the Astronomy Geographic Advantage Act. SKA South Africa therefore does not support the development of these projects as they are currently defined, or until further proof of concepts tests can be conducted to assess the efficacy of proposed mitigation measures, whereupon SKA South Africa will review the risk (review of this risk does not guarantee the risk can be reduced to an acceptable level).

This technical advice is provided by the South African SKA Project Office on the basis of the protection requirements of the SKA in South Africa, and does not constitute legal approval of the renewable energy projects in terms of the Astronomy Geographic Advantage Act, the Management Authority, and its regulations or declarations.

Regards,

Dr. Adrian Tiplady
Head of Strategy
SKA South Africa
Tel: 011 442 2434
Fax: 011 442 2454
atiplady@ska.ac.za



environmental affairs

Department:
Environmental Affairs
REPUBLIC OF SOUTH AFRICA

Private Bag X 447 · PRETORIA · 0001 · Environment House · 473 Steve Biko, Arcadia · PRETORIA
Tel (+ 27 12) 399 9372

DEA Reference: 14/12/16/3/3/2/766

Enquiries: Herman Alberts

Telephone: (012) 399 9371 E-mail: HAlberts@environment.gov.za

Ms Andrea Gibb
SiVEST Environmental Division
PO Box 2921
RIVONIA
2128

Telephone Number: (011) 798 0600
Email Address: andreag@sivest.co.za

PER EMAIL / MAIL

Dear Ms Gibb

REQUEST FOR AN EXTENSION OF TIMEFRAME FOR THE PROPOSED CONSTRUCTION OF THE HELENA 2 PHOTOVOLTAIC (PV) ENERGY FACILITY NEAR COPPERTON WITHIN THE SIYATHEMBA LOCAL MUNICIPALITY, NORTHERN CAPE PROVINCE

Your request for an extension of timeframe dated 10 June 2016 and received by this department on 10 June 2016, has reference.

The letter dated 10 June 2016 points out that BioTherm Energy and SiVEST have been in consultation with the Square Kilometre Array (SKA), who have informed BioTherm Energy that the proposed project could pose a high risk to the SKA. As a result, BioTherm Energy has already conducted electromagnetic interference (EMI) studies as requested by the SKA. The letter dated 10 June 2016 further request an extension to keep the file open in order to comply with the SKA's requirement that technical proof of concepts should be implemented and measured.

This Department has subsequently reviewed your request for an extension of timeframe for the proposed project and hereby **accepts** your request to keep the file open. The Department further advises that the application with DEA reference number 14/12/16/3/3/2/766 for the Proposed Construction of the Helena 2 Photovoltaic (PV) Energy Facility near Copperton within the Siyathemba Local Municipality in the Northern Cape Province will remain open on the Departmental system.

In light of the above, this Department requests that all outstanding information be submitted in accordance with the EIA Regulations, 2010 **within six (06) months from the date of signature of this letter**. Failure to submit the required information within this period will result in the application for Environmental Authorisation (EA) lapsing and the file being closed. **Please note that no further extension will be granted.**

You are hereby reminded of Section 24F of the National Environmental Management Act, Act No 107 of 1998, as amended, that no activity may commence prior to an environmental authorisation being granted by the Department.

Yours faithfully

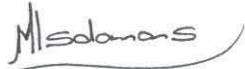

Mr Sabelo Malaza

Chief Director: Integrated Environmental Authorisations

Department of Environmental Affairs

Letter Signed by: Ms Milicent Solomons

Designation: Director: Strategic Infrastructure Developments

Date: 06/07/2016.

cc:	Jasandra Nyker	BioTherm Energy (Pty) Ltd	E-mail: eiaadmin@biothermenergy.com
	Thulani Mthombeni	NC DENC	E-mail: tmtho@webmail.co.za
	JRM Alexander	Siyathemba Local Municipality	E-mail: mm@siyathemba.gov.za



Appendix 4: Declarations of Interest



environmental affairs

Department:
Environmental Affairs
REPUBLIC OF SOUTH AFRICA

DETAILS OF SPECIALIST AND DECLARATION OF INTEREST

	(For official use only)
File Reference Number:	Helena Solar 1 – DEA Ref No: 14/12/16/3/3/2/765 Helena Solar 2 – DEA Ref No: 14/12/16/3/3/2/766 Helena Solar 3 – DEA Ref No: 14/12/16/3/3/2/767
NEAS Reference Number:	DEA/EIA
Date Received:	

Application for integrated environmental authorisation and waste management licence in terms of the-

- (1) National Environmental Management Act, 1998 (Act No. 107 of 1998), as amended and the Environmental Impact Assessment Regulations, 2014; and
- (2) National Environmental Management Act: Waste Act, 2008 (Act No. 59 of 2008) and Government Notice 921, 2013

PROJECT TITLE

Proposed Construction of the Helena three phased Solar Photovoltaic (PV) Power Plant near Copperton, Northern Cape Province

Specialist:	Andrea Gibb		
Contact person:	Andrea Gibb		
Postal address:	P O Box 2921, Rivonia, South Africa		
Postal code:	2128	Cell:	072 587 6525
Telephone:	011 798 0638	Fax:	011 803 7272
E-mail:	andreaq@sivest.co.za		
Professional affiliation(s) (if any)			
Project Consultant:	SiVEST SA (Pty) Ltd		
Contact person:	Andrea Gibb		
Postal address:	P O Box 2921, Rivonia, South Africa		
Postal code:	2128	Cell:	072 587 6525
Telephone:	011 798 0638	Fax:	011 803 7272
E-mail:	andreaq@sivest.co.za		

4.2 The specialist appointed in terms of the Regulations_

I, Andrea Gibb, declare that --

General declaration:

I act as the independent specialist in this application;

I will perform the work relating to the application in an objective manner, even if this results in views and findings that are not favourable to the applicant;

I declare that there are no circumstances that may compromise my objectivity in performing such work;

I have expertise in conducting the specialist report relevant to this application, including knowledge of the Act, Regulations and any guidelines that have relevance to the proposed activity;

I will comply with the Act, Regulations and all other applicable legislation;

I have no, and will not engage in, conflicting interests in the undertaking of the activity;

I undertake to disclose to the applicant and the competent authority all material information in my possession that reasonably has or may have the potential of influencing - any decision to be taken with respect to the application by the competent authority; and - the objectivity of any report, plan or document to be prepared by myself for submission to the competent authority;

all the particulars furnished by me in this form are true and correct; and

I realise that a false declaration is an offence in terms of regulation 48 and is punishable in terms of section 24F of the Act.



Signature of the specialist:

SiVEST SA (Pty) Ltd

Name of company (if applicable):

25 March 2015

Date:



environmental affairs

Department:
Environmental Affairs
REPUBLIC OF SOUTH AFRICA

DETAILS OF SPECIALIST AND DECLARATION OF INTEREST

	(For official use only)
File Reference Number:	Helena Solar 1 – DEA Ref No: 14/12/16/3/3/2/765 Helena Solar 2 – DEA Ref No: 14/12/16/3/3/2/766 Helena Solar 3 – DEA Ref No: 14/12/16/3/3/2/767
NEAS Reference Number:	DEA/EIA
Date Received:	

Application for integrated environmental authorisation and waste management licence in terms of the-

- (1) National Environmental Management Act, 1998 (Act No. 107 of 1998), as amended and the Environmental Impact Assessment Regulations, 2014; and
- (2) National Environmental Management Act: Waste Act, 2008 (Act No. 59 of 2008) and Government Notice 921, 2013

PROJECT TITLE

Proposed Construction of the Helena three phased Solar Photovoltaic (PV) Power Plant near Copperton, Northern Cape Province

Specialist:	SiVEST SA (Pty) Ltd		
Contact person:	Shaun Taylor		
Postal address:	P O Box 2921, Rivonia, South Africa		
Postal code:	2128	Cell:	072 779 4899
Telephone:	011 798 0691	Fax:	011 803 7272
E-mail:	shaunt@sivest.co.za		
Professional affiliation(s) (if any)	South African Wetland Society		

Project Consultant:	SiVEST SA (Pty) Ltd		
Contact person:	Andrea Gibb		
Postal address:	P O Box 2921, Rivonia, South Africa		
Postal code:	2128	Cell:	072 587 6525
Telephone:	011 798 0638	Fax:	011 803 7272
E-mail:	andrea@sivest.co.za		

4.2 The specialist appointed in terms of the Regulations_

I, Shaun Taylor, declare

that -- General declaration:

I act as the independent specialist in this application;

I will perform the work relating to the application in an objective manner, even if this results in views and findings that are not favourable to the applicant;

I declare that there are no circumstances that may compromise my objectivity in performing such work;

I have expertise in conducting the specialist report relevant to this application, including knowledge of the Act, Regulations and any guidelines that have relevance to the proposed activity;

I will comply with the Act, Regulations and all other applicable legislation;

I have no, and will not engage in, conflicting interests in the undertaking of the activity;

I undertake to disclose to the applicant and the competent authority all material information in my possession that reasonably has or may have the potential of influencing - any decision to be taken with respect to the application by the competent authority; and - the objectivity of any report, plan or document to be prepared by myself for submission to the competent authority;

all the particulars furnished by me in this form are true and correct; and

I realise that a false declaration is an offence in terms of regulation 48 and is punishable in terms of section 24F of the Act.



Signature of the specialist:

SiVEST SA (Pty) Ltd

Name of company (if applicable):

25 March 2015

Date:



environmental affairs

Department:
Environmental Affairs
REPUBLIC OF SOUTH AFRICA

DETAILS OF SPECIALIST AND DECLARATION OF INTEREST

	(For official use only)
File Reference Number:	Helena Solar 1 – DEA Ref No: 14/12/16/3/3/2/765 Helena Solar 2 – DEA Ref No: 14/12/16/3/3/2/766 Helena Solar 3 – DEA Ref No: 14/12/16/3/3/2/767
NEAS Reference Number:	DEA/EIA
Date Received:	

Application for integrated environmental authorisation and waste management licence in terms of the-

- (1) National Environmental Management Act, 1998 (Act No. 107 of 1998), as amended and the Environmental Impact Assessment Regulations, 2014; and
- (2) National Environmental Management Act: Waste Act, 2008 (Act No. 59 of 2008) and Government Notice 921, 2013

PROJECT TITLE

Proposed Construction of the Helena three phased Solar Photovoltaic (PV) Power Plant near Copperton, Northern Cape Province

Specialist:	ARC-Institute for Soil, Climate and Water		
Contact person:	Garry Paterson		
Postal address:	Private Bag X79, Pretoria		
Postal code:	0001	Cell:	083 556 2458
Telephone:	012 310 2601	Fax:	012 323 1157
E-mail:	garry@arc.agric.za		
Professional affiliation(s) (if any)			
Project Consultant:	SiVEST SA (Pty) Ltd		
Contact person:	Andrea Gibb		
Postal address:	P O Box 2921, Rivonia, South Africa		
Postal code:	2128	Cell:	072 587 6525
Telephone:	011 798 0638	Fax:	011 803 7272
E-mail:	andreag@sivest.co.za		

4.2 The specialist appointed in terms of the Regulations_

I, ~~DG PATERSON~~, declare that -- General declaration:

I act as the independent specialist in this application;
I will perform the work relating to the application in an objective manner, even if this results in views and findings that are not favourable to the applicant;
I declare that there are no circumstances that may compromise my objectivity in performing such work;
I have expertise in conducting the specialist report relevant to this application, including knowledge of the Act, Regulations and any guidelines that have relevance to the proposed activity;
I will comply with the Act, Regulations and all other applicable legislation;
I have no, and will not engage in, conflicting interests in the undertaking of the activity;
I undertake to disclose to the applicant and the competent authority all material information in my possession that reasonably has or may have the potential of influencing - any decision to be taken with respect to the application by the competent authority; and - the objectivity of any report, plan or document to be prepared by myself for submission to the competent authority;
all the particulars furnished by me in this form are true and correct; and
I realise that a false declaration is an offence in terms of regulation 48 and is punishable in terms of section 24F of the Act.

Signature of the specialist:



Name of company (if applicable): ARC-Institute for Soil, Climate and Water

Date: 1st April 2015



environmental affairs

Department:
Environmental Affairs
REPUBLIC OF SOUTH AFRICA

DETAILS OF SPECIALIST AND DECLARATION OF INTEREST

	(For official use only)
File Reference Number:	Helena Solar 1 – DEA Ref No: 14/12/16/3/3/2/765 Helena Solar 2 – DEA Ref No: 14/12/16/3/3/2/766 Helena Solar 3 – DEA Ref No: 14/12/16/3/3/2/767
NEAS Reference Number:	DEA/EIA
Date Received:	

Application for integrated environmental authorisation and waste management licence in terms of the-

- (1) National Environmental Management Act, 1998 (Act No. 107 of 1998), as amended and the Environmental Impact Assessment Regulations, 2014; and
- (2) National Environmental Management Act: Waste Act, 2008 (Act No. 59 of 2008) and Government Notice 921, 2013

PROJECT TITLE

Proposed Construction of the Helena three phased Solar Photovoltaic (PV) Power Plant near Copperton, Northern Cape Province

Specialist:	Urban-Econ Development Economists		
Contact person:	Memory Madondo		
Postal address:	Po Box 13554, Hatfield		
Postal code:	0028	Cell:	073 936 2660
Telephone:	012 342 8686	Fax:	012 342 8688
E-mail:	memory@urban-econ.com		
Professional affiliation(s) (if any)			

Project Consultant:	SIVEST SA (Pty) Ltd		
Contact person:	Andrea Gibb		
Postal address:	P O Box 2921, Rivonia, South Africa		
Postal code:	2128	Cell:	072 587 6525
Telephone:	011 798 0638	Fax:	011 803 7272
E-mail:	andrea@sivest.co.za		

4.2 The specialist appointed in terms of the Regulations_

I, **Memory Madondo** _____, declare that --

General declaration:

I act as the independent specialist in this application;

I will perform the work relating to the application in an objective manner, even if this results in views and findings that are not favourable to the applicant;

I declare that there are no circumstances that may compromise my objectivity in performing such work;

I have expertise in conducting the specialist report relevant to this application, including knowledge of the Act, Regulations and any guidelines that have relevance to the proposed activity;

I will comply with the Act, Regulations and all other applicable legislation;

I have no, and will not engage in, conflicting interests in the undertaking of the activity;

I undertake to disclose to the applicant and the competent authority all material information in my possession that reasonably has or may have the potential of influencing - any decision to be taken with respect to the application by the competent authority; and - the objectivity of any report, plan or document to be prepared by myself for submission to the competent authority;

all the particulars furnished by me in this form are true and correct; and

I realise that a false declaration is an offence in terms of regulation 48 and is punishable in terms of section 24F of the Act.



Signature of the specialist:

Urban-Econ Development Economists

Name of company (if applicable):

18 March 2015

Date:



environmental affairs

Department:
Environmental Affairs
REPUBLIC OF SOUTH AFRICA

DETAILS OF SPECIALIST AND DECLARATION OF INTEREST

	(For official use only)
File Reference Number:	Helena Solar 1 – DEA Ref No: 14/12/16/3/3/2/765 Helena Solar 2 – DEA Ref No: 14/12/16/3/3/2/766 Helena Solar 3 – DEA Ref No: 14/12/16/3/3/2/767
NEAS Reference Number:	DEA/EIA
Date Received:	

Application for integrated environmental authorisation and waste management licence in terms of the-

- (1) National Environmental Management Act, 1998 (Act No. 107 of 1998), as amended and the Environmental Impact Assessment Regulations, 2014; and
- (2) National Environmental Management Act: Waste Act, 2008 (Act No. 59 of 2008) and Government Notice 921, 2013

PROJECT TITLE

Proposed Construction of the Helena three phased Solar Photovoltaic (PV) Power Plant near Copperton, Northern Cape Province

Specialist:	Urban-Econ Development Economists		
Contact person:	Elena Broughton		
Postal address:	Po Box 13554, Hatfield		
Postal code:	0028	Cell:	082 463 2325
Telephone:	012 342 8686	Fax:	012 342 8688
E-mail:	elena@urban-econ.com		
Professional affiliation(s) (if any)			

Project Consultant:	SiVEST SA (Pty) Ltd		
Contact person:	Andrea Gibb		
Postal address:	P O Box 2921, Rivonia, South Africa		
Postal code:	2128	Cell:	072 587 6525
Telephone:	011 798 0638	Fax:	011 803 7272
E-mail:	andrea@sivest.co.za		

4.2 The specialist appointed in terms of the Regulations_

I, **Elena Broughton** _____, declare that --

General declaration:

I act as the independent specialist in this application;

I will perform the work relating to the application in an objective manner, even if this results in views and findings that are not favourable to the applicant;

I declare that there are no circumstances that may compromise my objectivity in performing such work;

I have expertise in conducting the specialist report relevant to this application, including knowledge of the Act, Regulations and any guidelines that have relevance to the proposed activity;

I will comply with the Act, Regulations and all other applicable legislation;

I have no, and will not engage in, conflicting interests in the undertaking of the activity;

I undertake to disclose to the applicant and the competent authority all material information in my possession that reasonably has or may have the potential of influencing - any decision to be taken with respect to the application by the competent authority; and - the objectivity of any report, plan or document to be prepared by myself for submission to the competent authority;

all the particulars furnished by me in this form are true and correct; and

I realise that a false declaration is an offence in terms of regulation 48 and is punishable in terms of section 24F of the Act.



Signature of the specialist:

Urban-Econ Development Economists

Name of company (if applicable):

18 March 2015

Date:



environmental affairs

Department:
Environmental Affairs
REPUBLIC OF SOUTH AFRICA

DETAILS OF SPECIALIST AND DECLARATION OF INTEREST

	(For official use only)
File Reference Number:	Helena Solar 1 – DEA Ref No: 14/12/16/3/3/2/765 Helena Solar 2 – DEA Ref No: 14/12/16/3/3/2/766 Helena Solar 3 – DEA Ref No: 14/12/16/3/3/2/767
NEAS Reference Number:	DEA/EIA
Date Received:	

Application for integrated environmental authorisation and waste management licence in terms of the-

- (1) National Environmental Management Act, 1998 (Act No. 107 of 1998), as amended and the Environmental Impact Assessment Regulations, 2014; and
- (2) National Environmental Management Act: Waste Act, 2008 (Act No. 59 of 2008) and Government Notice 921, 2013

PROJECT TITLE

Proposed Construction of the Helena three phased Solar Photovoltaic (PV) Power Plant near Copperton, Northern Cape Province

Specialist:	PGS Heritage		
Contact person:	Wouter Fourie		
Postal address:	PO Box 32542, Totiusdal		
Postal code:	0134	Cell:	0828513575
Telephone:	012 332 5305	Fax:	0866758077
E-mail:	wouter@pgsheritage.co.za		
Professional affiliation(s) (if any)	Association of Sothern African Professional Archaeologists (ASAPA) Association of Professional Heritage Practitioners (APHP)		
Project Consultant:	SiVEST SA (Pty) Ltd		
Contact person:	Andrea Gibb		
Postal address:	P O Box 2921, Rivonia, South Africa		
Postal code:	2128	Cell:	072 587 6525
Telephone:	011 798 0638	Fax:	011 803 7272
E-mail:	andreag@sivest.co.za		

4.2 The specialist appointed in terms of the Regulations_

I, Wouter Fourie, declare that --

General declaration:

I act as the independent specialist in this application;

I will perform the work relating to the application in an objective manner, even if this results in views and findings that are not favourable to the applicant;

I declare that there are no circumstances that may compromise my objectivity in performing such work;

I have expertise in conducting the specialist report relevant to this application, including knowledge of the Act, Regulations and any guidelines that have relevance to the proposed activity;

I will comply with the Act, Regulations and all other applicable legislation;

I have no, and will not engage in, conflicting interests in the undertaking of the activity;

I undertake to disclose to the applicant and the competent authority all material information in my possession that reasonably has or may have the potential of influencing - any decision to be taken with respect to the application by the competent authority; and - the objectivity of any report, plan or document to be prepared by myself for submission to the competent authority;

all the particulars furnished by me in this form are true and correct; and

I realise that a false declaration is an offence in terms of regulation 48 and is punishable in terms of section 24F of the Act.

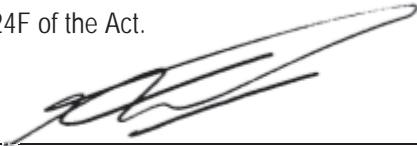

Signature of the specialist:

PGS Heritage

Name of company (if applicable):

19 March 2014

Date:



environmental affairs

Department:
Environmental Affairs
REPUBLIC OF SOUTH AFRICA

DETAILS OF EAP AND DECLARATION OF INTEREST

	(For official use only)
File Reference Number:	Helena Solar 1 – DEA Ref No: 14/12/16/3/3/2/765 Helena Solar 2 – DEA Ref No: 14/12/16/3/3/2/766 Helena Solar 3 – DEA Ref No: 14/12/16/3/3/2/767
NEAS Reference Number:	DEA/EIA
Date Received:	

Application for integrated environmental authorisation and waste management licence in terms of the-

- (1) National Environmental Management Act, 1998 (Act No. 107 of 1998), as amended and the Environmental Impact Assessment Regulations, 2014; and
- (2) National Environmental Management Act: Waste Act, 2008 (Act No. 59 of 2008) and Government Notice 921, 2013

PROJECT TITLE

Proposed Construction of the Helena three phased Solar Photovoltaic (PV) Power Plant near Copperton, Northern Cape Province

Environmental Assessment Practitioner (EAP):	SiVEST SA (Pty) Ltd		
Contact person:	Andrea Gibb		
Postal address:	P O Box 2921, Rivonia, South Africa		
Postal code:	2128	Cell:	072 587 6525
Telephone:	011 798 0638	Fax:	011 803 7272
E-mail:	andreaq@sivest.co.za		
Professional affiliation(s) (if any)			

Project Consultant:	SiVEST SA (Pty) Ltd		
Contact person:	Andrea Gibb		
Postal address:	P O Box 2921, Rivonia, South Africa		
Postal code:	2128	Cell:	072 587 6525
Telephone:	011 798 0638	Fax:	011 803 7272
E-mail:	andreaq@sivest.co.za		

4.2 The Environmental Assessment Practitioner

I, Andrea Gibb, declare that –

General declaration:

I act as the independent environmental practitioner in this application;
I will perform the work relating to the application in an objective manner, even if this results in views and findings that are not favourable to the applicant;
I declare that there are no circumstances that may compromise my objectivity in performing such work;
I have expertise in conducting environmental impact assessments, including knowledge of the Act, regulations and any guidelines that have relevance to the proposed activity;
I will comply with the Act, Regulations and all other applicable legislation;
I will take into account, to the extent possible, the matters listed in regulation 8 of the Regulations when preparing the application and any report relating to the application;
I have no, and will not engage in, conflicting interests in the undertaking of the activity;
I undertake to disclose to the applicant and the competent authority all material information in my possession that reasonably has or may have the potential of influencing - any decision to be taken with respect to the application by the competent authority; and - the objectivity of any report, plan or document to be prepared by myself for submission to the competent authority;
I will ensure that information containing all relevant facts in respect of the application is distributed or made available to interested and affected parties and the public and that participation by interested and affected parties is facilitated in such a manner that all interested and affected parties will be provided with a reasonable opportunity to participate and to provide comments on documents that are produced to support the application;
I will ensure that the comments of all interested and affected parties are considered and recorded in reports that are submitted to the competent authority in respect of the application, provided that comments that are made by interested and affected parties in respect of a final report that will be submitted to the competent authority may be attached to the report without further amendment to the report;
I will keep a register of all interested and affected parties that participated in a public participation process;
I will provide the competent authority with access to all information at my disposal regarding the application, whether such information is favourable to the applicant or not;
all the particulars furnished by me in this form are true and correct;
will perform all other obligations as expected from an environmental assessment practitioner in terms of the Regulations; and
I realise that a false declaration is an offence in terms of regulation 48 and is punishable in terms of section 24F of the Act.

Disclosure of Vested Interest (delete whichever is not applicable)

I do not have and will not have any vested interest (either business, financial, personal or other) in the proposed activity proceeding other than remuneration for work performed in terms of the Environmental Impact Assessment Regulations, 2014;

~~— I have a vested interest in the proposed activity proceeding, such vested interest being:~~



Signature of the environmental assessment practitioner:

SIVEST SA (Pty) Ltd

Name of company:

25 March 2015

Date:



environmental affairs

Department:
Environmental Affairs
REPUBLIC OF SOUTH AFRICA

DETAILS OF SPECIALIST AND DECLARATION OF INTEREST

	(For official use only)
File Reference Number:	Helena Solar 1 – DEA Ref No: 14/12/16/3/3/2/765 Helena Solar 2 – DEA Ref No: 14/12/16/3/3/2/766 Helena Solar 3 – DEA Ref No: 14/12/16/3/3/2/767
NEAS Reference Number:	DEA/EIA
Date Received:	

Application for integrated environmental authorisation and waste management licence in terms of the-

- (1) National Environmental Management Act, 1998 (Act No. 107 of 1998), as amended and the Environmental Impact Assessment Regulations, 2014; and
- (2) National Environmental Management Act: Waste Act, 2008 (Act No. 59 of 2008) and Government Notice 921, 2013

PROJECT TITLE

Proposed Construction of the Helena three phased Solar Photovoltaic (PV) Power Plant near Copperton, Northern Cape Province

Specialist:	David Hoare Consulting cc
Contact person:	David Hoare
Postal address:	Postnet Suite 116, P.B. X 025, Lynnwood Ridge
Postal code:	0040
Telephone:	012 804 2281
E-mail:	dhoare@lantix.net
Professional affiliation(s) (if any)	SACNASP (Pri Sci Nat)

Project Consultant:	SIVEST SA (Pty) Ltd
Contact person:	Andrea Gibb
Postal address:	P O Box 2921, Rivonia, South Africa
Postal code:	2128
Telephone:	011 798 0638
E-mail:	andreaq@sivest.co.za

4.2 The specialist appointed in terms of the Regulations_

I, David Hoare, declare that --

General declaration:

I act as the independent specialist in this application;

I will perform the work relating to the application in an objective manner, even if this results in views and findings that are not favourable to the applicant;

I declare that there are no circumstances that may compromise my objectivity in performing such work;

I have expertise in conducting the specialist report relevant to this application, including knowledge of the Act, Regulations and any guidelines that have relevance to the proposed activity;

I will comply with the Act, Regulations and all other applicable legislation;

I have no, and will not engage in, conflicting interests in the undertaking of the activity;

I undertake to disclose to the applicant and the competent authority all material information in my possession that reasonably has or may have the potential of influencing - any decision to be taken with respect to the application by the competent authority; and - the objectivity of any report, plan or document to be prepared by myself for submission to the competent authority;

all the particulars furnished by me in this form are true and correct; and

I realise that a false declaration is an offence in terms of regulation 48 and is punishable in terms of section 24F of the Act.

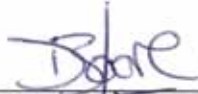

Signature of the specialist:

David Hoare Consulting cc

Name of company (if applicable):

23 March 2015

Date:



environmental affairs

Department:
Environmental Affairs
REPUBLIC OF SOUTH AFRICA

DETAILS OF SPECIALIST AND DECLARATION OF INTEREST

	(For official use only)
File Reference Number:	Helena Solar 1 – DEA Ref No: 14/12/16/3/3/2/765 Helena Solar 2 – DEA Ref No: 14/12/16/3/3/2/766 Helena Solar 3 – DEA Ref No: 14/12/16/3/3/2/767
NEAS Reference Number:	DEA/EIA
Date Received:	

Application for integrated environmental authorisation and waste management licence in terms of the-

- (1) National Environmental Management Act, 1998 (Act No. 107 of 1998), as amended and the Environmental Impact Assessment Regulations, 2014; and
- (2) National Environmental Management Act: Waste Act, 2008 (Act No. 59 of 2008) and Government Notice 921, 2013

PROJECT TITLE

Proposed Construction of the Helena three phased Solar Photovoltaic (PV) Power Plant near Copperton, Northern Cape Province

Specialist:	Chris van Rooyen Consulting		
Contact person:	Chris van Rooyen		
Postal address:	30 Roosevelt Street, Robindale, Randburg		
Postal code:	2194	Cell:	0824549570
Telephone:	011 7827204	Fax:	
E-mail:	Vanrooyen.chris@gmail.com		
Professional affiliation(s) (if any)	-		
Project Consultant:	SiVEST SA (Pty) Ltd		
Contact person:	Andrea Gibb		
Postal address:	P O Box 2921, Rivonia, South Africa		
Postal code:	2128	Cell:	072 587 6525
Telephone:	011 798 0638	Fax:	011 803 7272
E-mail:	andrea@sivest.co.za		

4.2 The specialist appointed in terms of the Regulations_

I, ~~Chris van Rooyen~~, declare that -- General declaration:

I act as the independent specialist in this application;
I will perform the work relating to the application in an objective manner, even if this results in views and findings that are not favourable to the applicant;
I declare that there are no circumstances that may compromise my objectivity in performing such work;
I have expertise in conducting the specialist report relevant to this application, including knowledge of the Act, Regulations and any guidelines that have relevance to the proposed activity;
I will comply with the Act, Regulations and all other applicable legislation;
I have no, and will not engage in, conflicting interests in the undertaking of the activity;
I undertake to disclose to the applicant and the competent authority all material information in my possession that reasonably has or may have the potential of influencing - any decision to be taken with respect to the application by the competent authority; and - the objectivity of any report, plan or document to be prepared by myself for submission to the competent authority;
all the particulars furnished by me in this form are true and correct; and
I realise that a false declaration is an offence in terms of regulation 48 and is punishable in terms of section 24F of the Act.

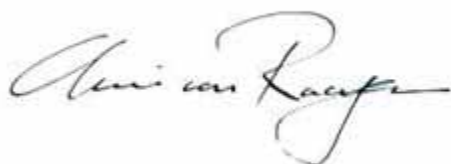

Signature of the specialist:

Chris van Rooyen Consulting

Name of company (if applicable):

18 March 2015

Date:

Your reference:

Our reference: 13031 – Helena 2

Date: 18 November 2016

AFFIRMATION BY ENVIRONMENTAL ASSESSMENT PRACTITIONER IN TERMS OF APPENDIX 2 AND 3 OF THE EIA REGULATIONS, 2014

PROJECT TITLE

Helena Solar 2: 75 MW Solar Photovoltaic (PV) Energy Facility near Copperton, Northern Cape Province

Environmental Assessment Practitioner (EAP):

Contact person:

Postal address:

Postal code:

Telephone:

E-mail:

SiVEST SA (Pty) Ltd

Andrea Gibb

P O Box 2921, Rivonia, South Africa

2128

011 798 0638

andreag@sivest.co.za

Cell:

072 587 6525

Fax:

011 803 7272

I, Andrea Gibb, the appointed EAP confirm through this affirmation (as required in terms of Appendix 2 subsection (2) (j) and (k) and Appendix 3 subsection (3) (s) of GN982) that –

- i) To the best of my knowledge the information provided in this report is factually correct;
- ii) All comments and inputs received from stakeholders / interested and affected parties, prior to submission of the report, have been included as part of the report, and addressed where necessary;
- iii) All relevant inputs and recommendations from the specialist reports have been included in the report;
- iv) To the best of my knowledge all relevant project information which has been provided to stakeholders and interested and affected parties is correct, and is included in the report;
- v) All responses provided to comments received from stakeholders and interested and affected parties are the unbiased opinion of the EAP and are based on factually correct information;
- vi) The level of agreement between the EAP and the interested and affected parties on the plan of study for the undertaking of the environmental impact assessment has been agreed upon.



Signature of the environmental assessment practitioner:

SiVEST SA (Pty) Ltd

Name of company:

18 November 2016

Date:



Appendix 5: Public Participation



**Appendix 5A:
EIA Newsletter**

Hlengiwe Ntuli

From: Hlengiwe Ntuli
Sent: 30 November 2015 02:52 PM
Cc: Andrea Gibb; Lynsey Rimbault
Subject: Helena 1, 2 and 3 Solar PV Facilities: EIA Newsletter
Attachments: 13031_Helena PV and Powerline EIA Newsletter Comment Form_Rev1_30Nov2016....pdf; 13031_Helena PV and Powerline EIA Newsletter_Rev 1_25Nov2015 LR.PDF; A3_13031_HS1_SiteLocality_LR.PDF

Tracking:	Recipient	Delivery	Read
	Andrea Gibb	Delivered: 2015/11/30 02:52 PM	Read: 2015/12/01 07:02 AM
	Lynsey Rimbault	Delivered: 2015/11/30 02:52 PM	Read: 2015/11/30 02:52 PM
	'Elsabe Swart'		
	'Keith Woolf'		
	'Lizell Stoh'		
	'Natalie Uys'		
	'Lorraine Nobela'		
	'Ntsundeni Ravhogoni'		
	'Heleen van den Heever'		
	'Amanda Bester'		
	'Rene De Kock'		
	'Shaun Dyers'		
	'Ferlicia Ward'		
	'Simpfiwe Masilela'		
	'Johanna Morobane'		
	'Jasper Nieuwoudt'		
	'Anneliza Collett'		
	'Thoko Buthelezi'		
	'Paul Avenant'		
	'Sonwabile Nkondeshe'		
	'Sindisile Madyo'		
	'Jack Maccollan'		
	'Miriam Kibi'		
	'Sam Diokpala'		
	'Johan Koegelenberg'		
	'Mere Kgampe'		
	'Thulani Mthombeni'		
	'Wynand Human'		
	'S Human'		
	'Johannes Human'		
	'Coenie Viljoen'		
	'Anton van Heerden'		
	'Eden William'		
	'Gert Steenkamp'		
	'Gerhardus Rudolph'		

Recipient	Delivery	Read
'Gerrie Rudolph'		
'Adriaan Tiplady'		
'Carolyn Ah Shene-Verdoorn'		
'Simon Gear'		
','		
'Jenna Lavin'		
'Bradley Gibbons'		
'Hendrik Human'		
'Suzanne Erasmus'		
'Nico Fourie'		
'Ivan Steenkamp'		
Lynsey Rimbault		
'Jacoline Mans'		
'Sam Fiff'		
'Andrew Timothy'		
'Piet Papier'		
'JRM Alexander'		
'Johan Badenhorst'		
'John Geeringh'		
'Raylene Stadhouer'		
'Berend van Deventer'		
'Thomas Botha'		
'Jermaine Isaacs'		
'Chetna Mistry'		
'Irene Richardson'		
'Lynsey Rimbault'		
'Onwabile Ndzumo'		
'Lourens Leeuwner'		
'William van Staden'		
'Danielle Julies'		
'Danster Muggen'		
'Benjamin Brendon Hendricks'		
'Sivemah Mdlokovama'		
'Ester Makungo'		
'Zak Barnard'		
'AG Nel'		
'Justin Langfred'		
'Le-Waine Kakora'		
'Mandisa Yawa'		
'Mashudu Mukoma'		
'Frank Andreas'		
'Abe Abrahams'		
'Almarette Nieuwoudt'		

Recipient	Delivery	Read
'Danie & Jomima Bernard'		
'Hester Meyer'		
'Beatrice Mondzinger'		
'Cheri Roberts'		
'Ernest Kubayi'		
'George Karsten'		
'Koos Botha'		
'Ertjies Taljaart'		
'Albertha Kellerman'		
'Jakob Basson'		
'Pilla Buis'		
'Tarryn -'		
'Nelson'		
'Alexia Hlengani'		
'Hettie B'		
'Hettie Morobisi'		
'Hano Hamman'		
'Constantine Hapzilambros'		

***** Please note that this email was sent from a NO REPLY email address. Please do not reply to this address as it is an unmonitored email account. *****

Dear Stakeholder

We would like to take this opportunity to inform you that the Department of Environmental Affairs has accepted the Final Scoping Reports and approved the Plan of Study for the Environmental Impact Phase of the Helena 1, 2, and 3 Solar Photovoltaic Energy Facilities.

Attached is the EIA Newsletter, Comment form and Site Locality Map for your information.

Kind Regards

Andrea Gibb (B.Sc. Landscape Architecture; B.Sc.(Hons) Environmental Management) Environmental Practitioner and Visual Specialist SiVEST Environmental Division

SiVEST is a Level 3 BBBEE Contributor

Direct +27 11 798 0638 Tel +27 11 798 0600 fax +27 11 803 7272
email andreg@sivest.co.za website www.sivest.co.za

Consulting Engineers - Project Managers - Environmental Consultants - Town and Regional Planners Durban - Johannesburg - Pietermaritzburg - Richards Bay - Ladysmith - Cape Town - Harare (Zimbabwe)

Your reference N/A
Our reference 13031
Date 30 November 2015

Dear Interested and/or Affected or Party,

ENVIRONMENTAL IMPACT ASSESSMENT (EIA) AND ENVIRONMENTAL MANAGEMENT PROGRAMME (EMPr) FOR THE THREE HELENA SOLAR PHOTOVOLTAIC (PV) ENERGY FACILITIES NEAR COPPERTON, NORTHERN CAPE PROVINCE

DEA Ref. HELENA SOLAR 1: 14/12/16/3/3/2/765
HELENA SOLAR 2: 14/12/16/3/3/2/766
HELENA SOLAR 3: 14/12/16/3/3/2/767

EIA NEWSLETTER

We trust that you, as a registered Interested and/or Affected Party (I&AP), have received all the various public documents that have been distributed to date regarding the three Environmental Impact Assessments (EIAs) that are being conducted for the proposed construction of the Helena Solar Photovoltaic (PV) Energy Facilities near Copperton, Northern Province. If you have not received the public documents, you are most welcome to submit your request to us, in writing by e-mail, fax or letter (contact details below), and we will forward the relevant document(s) that you are interested in.

This EIA Newsletter aims to further facilitate your understanding of the three proposed PV energy facilities and the EIA process, including the Public Participation Process, being followed. The first phase of the EIA process (i.e. the Environmental Scoping Study) has been completed, and the desktop/preliminary specialist assessments and EIA process have been captured in the Final Scoping Reports (FSRs). The FSRs and their supporting documents, including the Plan of Studies (PoS) for EIAs, were submitted to the Department of Environmental Affairs (DEA) on Monday the 17 August 2015 for acceptance.

The DEA accepted all three FSRs on the 20 October 2015 and indicated that the Department was satisfied with the content of the FSRs as well as the content in the PoS for the EIAs for the proposed developments as they comply with the minimum requirements of the EIA Guidelines (2010).

1. BRIEF OVERVIEW OF THE SCOPING PHASE

The proposed development is situated near Copperton and involves the construction of 3 X PV energy facilities each with a generation capacity of 75MW.

The Environmental Scoping Study identified and evaluated potential environmental impacts associated with all aspects of the proposed projects. In terms of the EIA Regulations, *feasible and reasonable* alternatives have been discussed within the Scoping Report.

2. IMPACT PHASE

The 3 X 75MW PV projects are being undertaken concurrently. In-depth environmental assessments were conducted by the various environmental specialists between the months of May 2015 and August 2015, as listed in Table 1 below.

During the Environmental Impact Phase, the Draft Environmental Impact Assessment Report (DEIAR) will be made available for public review and comment for a period of 30 days as legislated in the EIA Regulations 2010, and also before the Final Environmental Impact Assessment Report (FEIAR) is submitted to the DEA. The process to be followed during the EIA phase is indicated below.



Figure 1: Flow-chart of the EIA process to be followed during the Impact Phase

2.1. Site Layout

All three Helena solar PV facilities are located on Portion 3 of Klipgats Pan No 117 (PV site) and Portion 4 of Klipgats Pan No 117 (power lines). The site localities of the three proposed projects are shown in Figure 2. The total area of each project is indicated below:

- Helena PV1 has a footprint of approximately 427ha
- Helena PV2 has a footprint of approximately 267ha
- Helena PV3 has a footprint of approximately 527ha

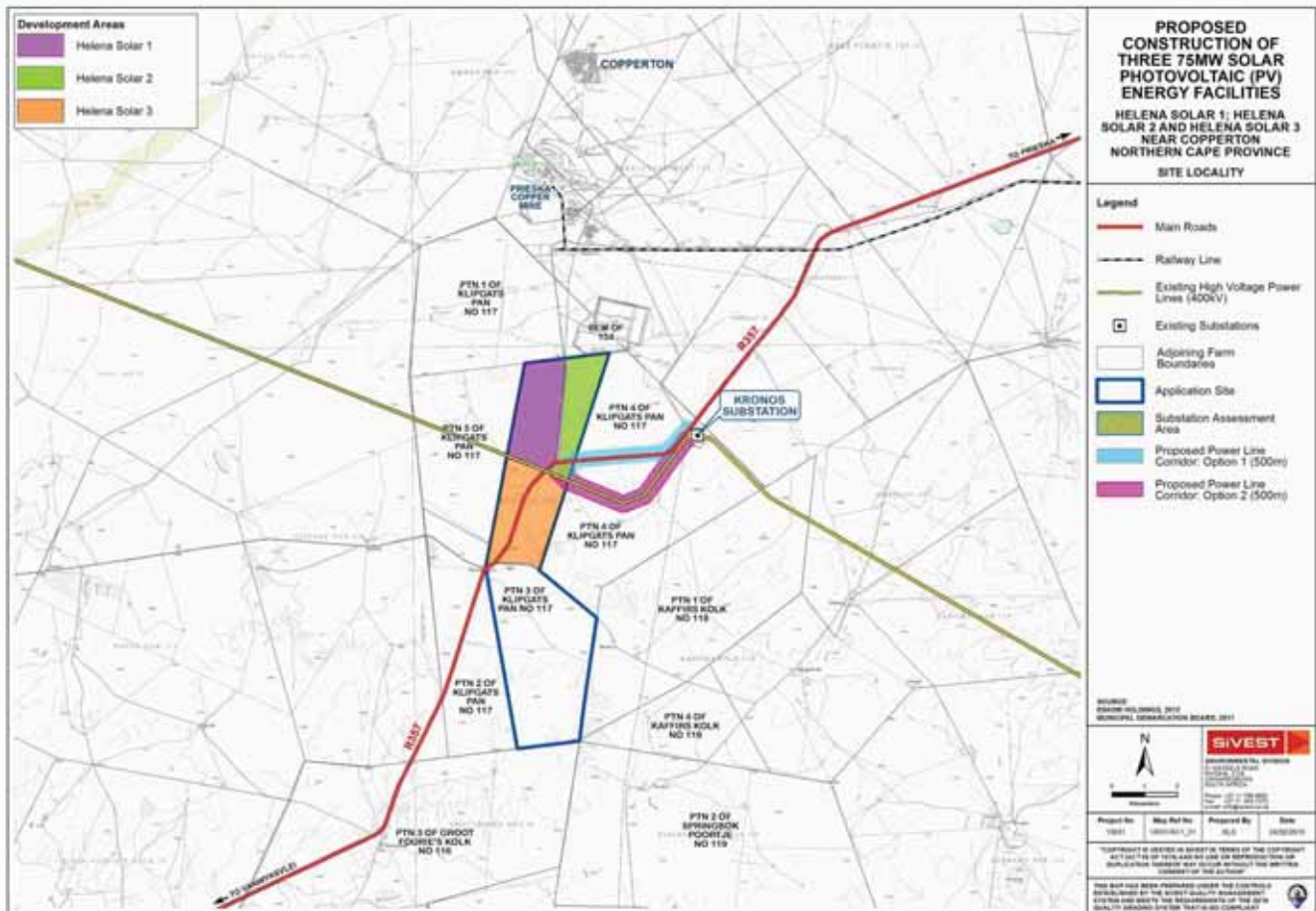

Figure 2: Proposed Site Localities for Helena 1, 2 and 3

The above-mentioned footprints for the proposed developments include anticipated associated infrastructure that will be constructed on each site.

The associated infrastructure per project will include the following:

- Approximately 274 000 to 281 000 **solar PV panels** with a total export capacity of 75MW;
- Onsite **switching station**, with the transformers for voltage step up from medium voltage to high voltage;
- Grid connection is to the Kronos substation. A **power line** with a voltage of 132kV is proposed and will run from the onsite substation to the Eskom Kronos substation. The distance will be approximately 5km;
- A **laydown area** for the temporary storage of materials during the construction activities;
- **Access roads and internal roads**;
- Construction of a **car park and fencing**; and
- **Administration, control and warehouse buildings**.

2.2. Environmental Studies Conducted

As previously stated, detailed environmental studies were conducted on Portion 3 of Klipgats Pan No 117 and Portion 4 of Klipgats Pan No 117. The specialist studies and specialists who conducted the studies are provided in the table below.

Table 1: Specialist studies and specialist conducting the studies

Name and Organisation	Role
Rebecca Thomas – SiVEST	Project Leader
Andrea Gibb – SiVEST	Environmental Assessment Practitioner (EAP) and Visual
Lynsey Rimbault – SiVEST	Environmental Consultant / Public Participation Practitioner
David Hoare – David Hoare Consulting	Biodiversity
Chris van Rooyen – Chris van Rooyen Consulting	Avifauna
Shaun Taylor and Alistair Fyfe – SiVEST	Surface Water
D.G. Paterson – ARC Institute for Soil, Climate and Water	Agricultural Potential
Wouter Fourie – PGS	Heritage
Elena Broughton and Memory Madondo – Urban-Econ Development Economists	Socio-economic
Nicolene Venter – Zitholele Consulting	Senior Public Participation Practitioner
Kerry Schwartz – SiVEST	GIS and Mapping

2.3. Environmental Management Programme (EMPr)

An Environmental Management Programme (EMPr) for each project will also be compiled by SiVEST as part of the Environmental Impact Phase. The EMPr details mitigation and management measures to be undertaken during the construction and operational phases, as well as the de-commissioning of the proposed PV power plant. Mitigation and management measures address potentially significant impacts associated with activities undertaken during the project phases in order to protect the environment (biophysical as well as social).

The draft EMPrs will be made available to I&APs for review and comments during the same review period of the DEIAs. After the review period the EMPrs will be submitted to DEA together with the FEIAs for review and decision-making. Should the DEA require any additional mitigation measures or monitoring activities, the EMPrs will be revised to include these recommendations. The EMPr is a tool to ensure that all mitigation requirements that are stipulated in the FEIAr are met and where relevant exceeded.

3. PUBLIC PARTICIPATION AND CONSULTATION PROCESS

Public involvement is one of the cornerstones of an effective environmental impact assessment as it is your comments that add value to the environmental process. We therefore, once again, request your active participation in this phase of the EIA as your knowledge of the local area will be valuable to the various specialist studies being undertaken.

The following chart outlines the Public Participation Process that will be followed:

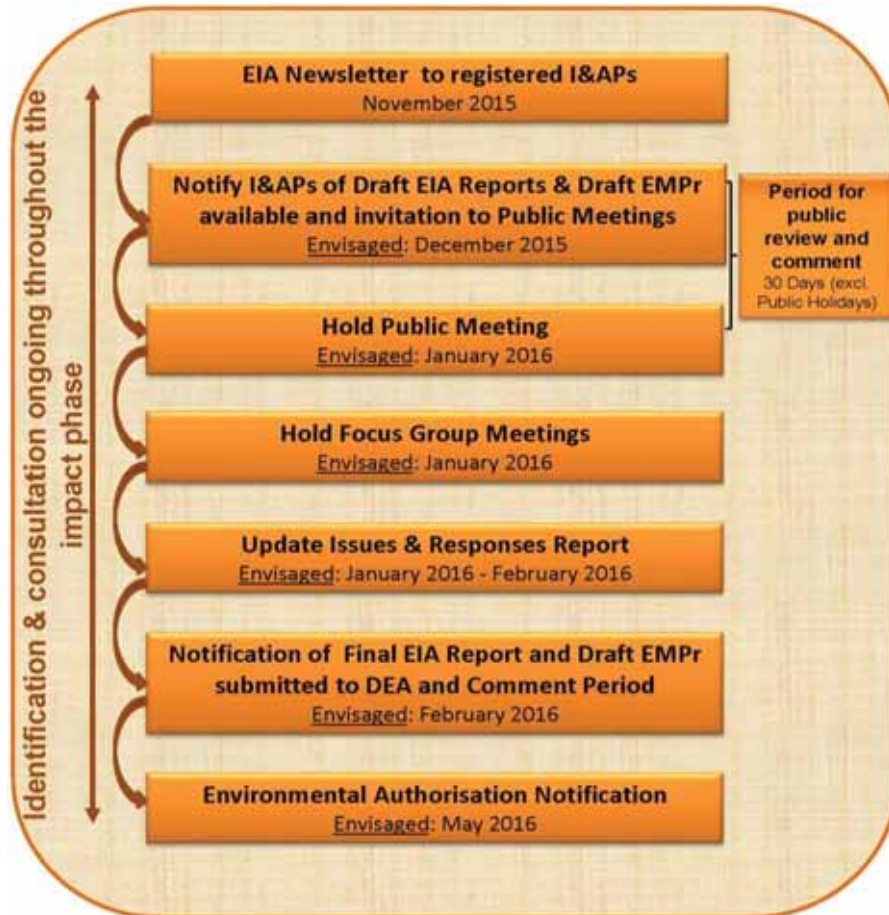

Figure 5: Flow-chart of the public participation process to be followed during the impact phase

4. WAY FORWARD

Please note that public involvement is a two-way communication and consultation process and we kindly request that you as an I&AP or possibly affected landowner:

- provide us with the contact details of your neighbour, friend or family member who you believe should be informed regarding the proposed 3 x 75MW solar PV energy facilities; or
- provide them with our contact details and request them to contact us directly.

As indicated in the public participation flow-chart, the public participation process is an ongoing process. You will thus be informed through personal correspondence and advertisements of the various stages of the EIA.

Should you, during this Impact Assessment Phase, require any additional information or wish to submit comments on the specialist studies or the proposed projects (Helena 1, Helena 2 and Helena 3), you are welcome to forward your inputs, in writing, to the Public Participation Office given below.

We look forward to your contributions.

COMMENTS AND QUERIES

Andrea Gibb or Lynsey Rimbault

 PO Box 2921, RIVONIA, 2128

 Phone: (011) 798 0600

 E-mail: andreag@sivest.co.za or lynseyr@sivest.co.za

 Fax: (011) 803 7272

Websites: www.sivest.co.za

Documents Included: Locality Map



Appendix 5B: Written Notices

Andrea Gibb

From: Veronique Evans
Sent: Wednesday, February 18, 2015 7:57 AM
Cc: Andrea Gibb; Rebecca Thomas; Nicolene Venter (nicolenev@zitholele.co.za); Lynsey Rimbault
Subject: EIA Commencing for Three 75MW Solar PV Energy Facilities near Copperton
Attachments: 13031 BID (ENG) FEB 2015.pdf; 13031 BID (AFR) FEB 2015.pdf; Helena PV Invite Letter Rev 1 10Feb2015 AG.pdf; Helena PV Invite Letter Rev 1 10Feb2015 AG Afr.pdf; Helena PV BID Reg Comm Form Rev 1_10Feb2015 AG.pdf; Helena PV BID Reg Comm Form Rev 1_10Feb2015 AG Afr.pdf

******* Please note that this email was sent from a NO REPLY email address. Please do not reply to this address as it is an unmonitored email account. *******

Dear Stakeholder

- Helena Solar 1 – DEA Ref No: 14/12/16/3/3/2/765
- Helena Solar 2 – DEA Ref No: 14/12/16/3/3/2/766
- Helena Solar 3 – DEA Ref No: 14/12/16/3/3/2/767

SiVEST SA (Pty) Ltd (hereafter referred to as SiVEST) has been appointed by BioTherm Energy (Pty) Ltd (hereafter referred to as BioTherm) to undertake the required Environmental Impact Assessment (EIA) process for the proposed development of a three phase solar photovoltaic (PV) energy facility with a total export capacity of 225MW, near Copperton within the Northern Cape Province. The proposed project will consist of three 75MW export capacity solar PV facilities referred to as Helena Solar 1, 2 and 3.

Please find attached, for your attention; the Background Information Document (BID), Invitation Letter and Registration and Comment Form for the proposed project. The documents are provided in English and Afrikaans for your convenience.

We look forward to receiving your comments.

Kind Regards

Andrea Gibb (B.Sc. Landscape Architecture; B.Sc.(Hons) Environmental Management)
Environmental Practitioner and Visual Specialist
SiVEST Environmental Division



SiVEST is a Level 3 BBBEE Contributor

Direct +27 11 798 0638 **Tel** +27 11 798 0600 **fax** +27 11 803 7272 **cell** +27 72 587 6525
email andreag@sivest.co.za **website** www.sivest.co.za



Consulting Engineers - Project Managers - Environmental Consultants - Town and Regional Planners
Durban - Johannesburg - Pietermaritzburg - Richards Bay - Ladysmith - Cape Town - Harare (Zimbabwe)

Your reference N/A
Our reference 13031
Date 18 February 2015

Dear Interested and/or Affected Party

ENVIRONMENTAL IMPACT ASSESSMENT (EIA) AND ENVIRONMENTAL MANAGEMENT PROGRAMME (EMPr) FOR THE PROPOSED DEVELOPMENT OF THREE 75MW SOLAR PHOTOVOLTAIC (PV) ENERGY FACILITIES NEAR COPPERTON, NORTHERN CAPE PROVINCE (HELENA SOLAR 1 – DEA Ref No: 14/12/16/3/3/2/765, HELENA SOLAR 2 – DEA Ref No: 14/12/16/3/3/2/766, HELENA SOLAR 3 – DEA Ref No: 14/12/16/3/3/2/767)

• **INVITATION TO PARTICIPATE IN THE ENVIRONMENTAL IMPACT ASSESSMENT PROCESS**

In terms of the EIA Regulations and the National Environmental Management Act, 1998 (Act No. 107 of 1998), SiVEST SA (Pty) Ltd (hereafter referred to as SiVEST) has been appointed as the independent Environmental Assessment Practitioner (EAP) by BioTherm Energy (Pty) Ltd (hereafter referred to as BioTherm) to conduct the EIA process for the proposed development of a three phase solar photovoltaic (PV) energy facility with a total export capacity of 225MW. The proposed project is located in the Northern Cape Province near Copperton and will consist of three 75MW export capacity solar PV facilities referred to as Helena Solar 1, 2 and 3. The project is registered with the Department of Environmental Affairs (DEA) under the following reference numbers:

- Helena Solar 1 – DEA Ref No: 14/12/16/3/3/2/765
- Helena Solar 2 – DEA Ref No: 14/12/16/3/3/2/766
- Helena Solar 3 – DEA Ref No: 14/12/16/3/3/2/767

SiVEST would like to invite you, as a potential Interested and/or Affected Party (I&AP), to become actively involved in the EIA and public participation process for this proposed project. The aim of this process are as follows:

- to ensure that all the relevant environmental impacts are taken into consideration;
- to ensure public input; and
- provide decision-makers with sufficient information to make an informed decision on the proposed activities.

Attached is the BID which contains information regarding the proposed project as well as the EIA and public participation process.

By completing and submitting the accompanying registration and comment form, you will be registered as an I&AP on the project database.

We would like to thank you, in advance, for becoming part of the public participation process and are looking forward to receiving your valuable comments relating to the proposed project.

Yours sincerely



Andrea Gibb
Environmental Practitioner
SiVEST Environmental Division

encl: Background Information Document
Registration and Comment Form

U verwysing N.V.T.
Ons verwysing 13031
Datum 18 Februarie 2015

Geagte Belangstellende en/of Geaffekteerde Party

OMGEWINGSIMPAKEVALUERING (OIE) EN OMGEWINGSBESTUURSPROGRAM (OBPr) VIR DIE VOORGESTELDE ONTWIKKELING VAN DRIE 75 MW FOTOVOLTAÏESE (FV) SONKRAGANLEGTE NABY COPPERTON, NOORD-KAAPROVINSIE (HELENA SOLAR 1 – DO Verw. No.: 14/12/16/3/3/2/765, HELENA SOLAR 2 – DO Verw. No.: 14/12/16/3/3/2/766, HELENA SOLAR 3 – DO Verw. No.: 14/12/16/3/3/2/767)

• **UITNODIGING OM DEELNAME AAN DIE OMGEWINGSIMPAKEVALUERINGSPROSES**

Ingevolge die OIE-regulasies en die Nasionale Wet op Omgewingsbestuur, 1998 (Wet 107 of 1998), het BioTherm Energy (Edms.) Bpk. (hierna BioTherm genoem) SiVEST SA (Edms.) Bpk (hierna SiVEST genoem) aangestel as die onafhanklike Omgewingsevalueringspraktisyn (OEP) ten einde die OIE-proses vir die voorgestelde ontwikkeling van 'n driefase fotovoltaïese (FV) sonkragaanleg met 'n totale uitvoervermoë van 225 MW te onderneem. Die voorgestelde projek is naby Copperton in die Noord-Kaapprovinsie geleë en sal bestaan uit drie FV-sonkragaanlegte met 'n uitvoervermoë van 75 MW elk wat as Helena Solar 1, 2 en 3 sal bekendstaan. Die projek is onder die volgende verwysingsnommers by die Departement van Omgewingsake (DO) geregistreer:

- Helena Solar 1 – DO Verw. No.: 14/12/16/3/3/2/765
- Helena Solar 2 – DO Verw. No.: 14/12/16/3/3/2/766
- Helena Solar 3 – DO Verw. No.: 14/12/16/3/3/2/767

SiVEST nooi u, as 'n potensiële Belangstellende en/of Geaffekteerde Party (B&GP), uit om aktief by die OIE en openbare deelnameproses vir hierdie voorgestelde projek betrokke te raak. Die doel van hierdie proses is om:

- toe te sien dat oorweging aan al die tersaaklike omgewingsimpakte geskenk word;
- openbare insette te verseker; en
- besluitnemers van voldoende inligting te voorsien om 'n ingeligte besluit oor die voorgestelde aktiwiteite te neem.

Die AID is aangeheg en bevat inligting oor die voorgestelde projek, asook die OIE- en openbare deelnameproses.

Deur die bygaande registrasie- en kommentaarvorm in te vul en in te dien, sal u outomaties as 'n B&GP op die projek se databasis geregistreer word.

Ons dank u by voorbaat dat u deel word van die openbare deelnameproses en ons sien uit daarna om u waardevolle kommentaar betreffende die voorgestelde projek te ontvang.

Die uwe



Andrea Gibb
Omgewingspraktisyn
SiVEST Omgewingsafdeling

Ingeslote dokumentasie: Agtergrondinligtingsdokument
Registrasie- en Kommentaarvorm

ENVIRONMENTAL IMPACT ASSESSMENT (EIA) AND ENVIRONMENTAL MANAGEMENT PROGRAMME (EMPr) FOR THE PROPOSED DEVELOPMENT OF THREE 75MW SOLAR PHOTOVOLTAIC (PV) ENERGY FACILITIES NEAR COPPERTON, NORTHERN CAPE PROVINCE

- HELENA SOLAR 1 – DEA Ref No: 14/12/16/3/3/2/765
- HELENA SOLAR 2 – DEA Ref No: 14/12/16/3/3/2/766
- HELENA SOLAR 3 – DEA Ref No: 14/12/16/3/3/2/767

SiVEST



BACKGROUND TO THE PROPOSED PROJECT

In support of, the need to find solutions for the current electricity shortages, the increasing demand

INTRODUCTION

BioTherm Energy (Pty) Ltd (hereafter referred to as BioTherm) are proposing to construct a three phase solar photovoltaic (PV) energy facility with a total export capacity of 225MW, near Copperton within the Northern Cape Province. The proposed project will consist of three 75MW export capacity solar PV facilities referred to as Helena Solar 1, 2 and 3.

In terms of the Environmental Impact Assessment (EIA) Regulations promulgated under Sections 24 and 24D of the National Environmental Management Act (Act No. 107 of 1998) (NEMA), various aspects of the proposed solar PV energy facilities are considered listed activities which may have an impact on the environment and therefore require authorisation from the National Department of Environmental Affairs (DEA) prior to the commencement of such activities. Although new EIA Regulations were promulgated on 4 December 2014 and came into effect on 8 December 2014 (Government Gazette No. 38282), the application forms for the proposed solar PV energy facilities were submitted to the DEA on 5 December 2014, prior to the 2014 EIA Regulations taking effect. In accordance with Regulation 53 (1) of the 2014 EIA Regulations, any applications submitted in terms of the previous NEMA regulations must be undertaken as if the previous NEMA regulations were not repealed.

The EIA process will therefore be undertaken in accordance with the 2010 EIA Regulations which are contained in four Government Notices (GN 543, 544, 545 and 546) which were promulgated on 18 June 2010 and came into effect on 02 August 2010.

BioTherm has therefore appointed SiVEST SA (Pty) Ltd (hereafter referred to as SiVEST) as the independent environmental assessment practitioner (EAP), to undertake the required EIA process in terms of the NEMA.

PURPOSE OF THIS DOCUMENT

The purpose of this Background Information Document (BID) is to inform Interested and/or Affected Parties (I&APs) about the EIA process that is being conducted for the proposed development.

In addition to supplying information about the proposed project and the EIA process, this BID will also provide I&APs with the opportunity to:

- Better understand the proposed project in order to provide comments and raise issues of concern;
- Understand the EIA process in order to participate effectively;
- Make suggestions to enhance the proposed project;
- Comment on the specialist studies that will be conducted; and
- Contribute local knowledge.

for energy, as well as the need to find more sustainable and environmentally friendly energy resources, South Africa has embarked on an infrastructure growth programme supported by various government initiatives. In order to achieve the long term goal of achieving a sustainable renewable energy industry, the Department of Energy has set a target of contributing 17,8GW of renewable energy to the final energy consumption by 2030. This target is to be produced mainly through, wind and solar; but also through biomass and small scale hydro (DME, 2003; IRP, 2010).

In response to this goal; BioTherm are proposing to establish three 75MW export capacity solar PV energy facilities near Copperton in the Northern Cape Province.

The overall objective of the project is to generate electricity to feed into Eskom's national electricity grid by means of renewable energy technologies.

WHY USE SOLAR ENERGY?

The benefits of using solar energy include:

- Solar PV facilities have the capability of delivering large-scale utility power;
- Solar energy is renewable, clean and non-polluting (greenhouse gases etc.), and does not produce by-products (atmospheric contaminants or thermal pollution) that could be harmful to the environment;

- Solar PV facilities are generally well suited to rural areas and therefore have a reduced impact on agriculture compared to other electricity generating options. Solar PV plants can also contribute to economic growth in these regions;
- Solar energy is one of the lowest-cost producer of electricity;
- Localised production of energy reduces transmission line losses associated with transmitting electricity over long distances;
- Solar PV facilities improve energy security for South Africa, reducing dependency on fossil fuels.

PROJECT LOCATION

The proposed project is located within the Northern Cape Province approximately 9km south of Copperton. It falls within the Siyathemba Local Municipality that forms part of the Pixley ka Seme District Municipality. The project includes the following farms:

- Portion 3 of the farm Klipgatspan No. 117 (solar facilities)
- Portion 4 of the farm Klipgatspan No. 117 (power line)

The project site near Copperton has been identified through pre-feasibility studies conducted by BioTherm based on an estimation of the solar energy resource as well as weather, dust, dirt, and surface albedo. Grid connection and land availability were also important initial considerations. The application site for the three proposed solar PV energy facilities is shown on the locality map (Figure 1).

TECHNICAL DETAILS

At this stage, it is proposed that each solar PV energy facility will consist of the following components:

- Approximately 300 000 solar PV panels with a total export capacity capacity of 75MW;
- Panels will be either fixed axis mounting or single axis tracking solutions (Figure 2), and will be either crystalline silicon or thin film technology;
- Switching station, with the transformers for voltage step up from medium voltage to high voltage;
- The panels will be connected in strings to inverters. For a 75MW size facility, typically 2MW inverter stations which are containerised stations housing 2x1MW inverters and 1x2MVA transformers will be used; therefore approximately 43 inverter stations will be required throughout the site;
- DC power from the panels will be converted into AC power in the inverters and the voltage will be stepped up to 22-33kV (medium voltage) in the transformers (Figure 3).
- The 22-33kV cables will be run underground in the facility to a common point before being fed to the onsite substation where the voltage will typically be stepped up to 132kV.
- Grid connection is to the Kronos substation. A Power line of less than 275kV will run from the onsite substation to the Kronos substation. The distance will be about 4km. A lay-down area for the temporary storage of materials during the construction activities;
- Access roads and internal roads;
- Construction of a car park and fencing around the project; and
- Administration, control and warehouse buildings

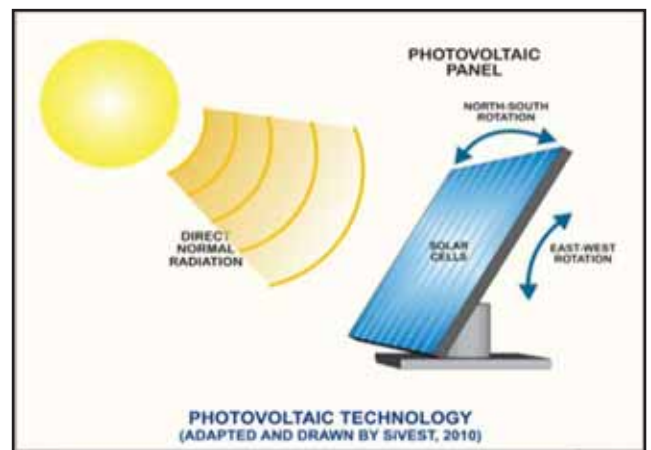
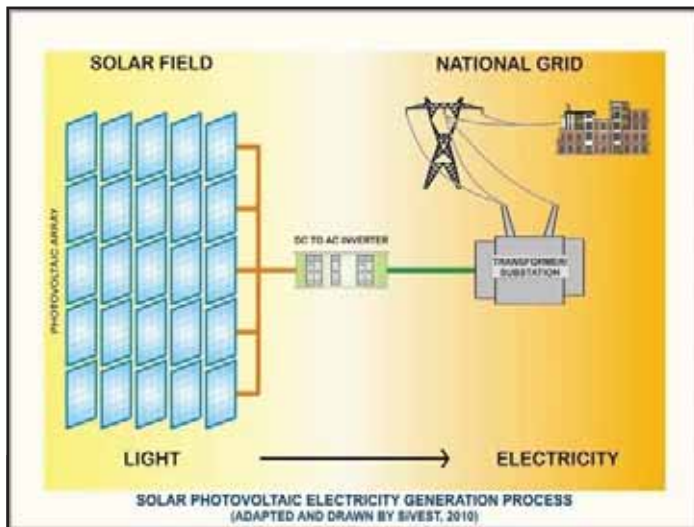
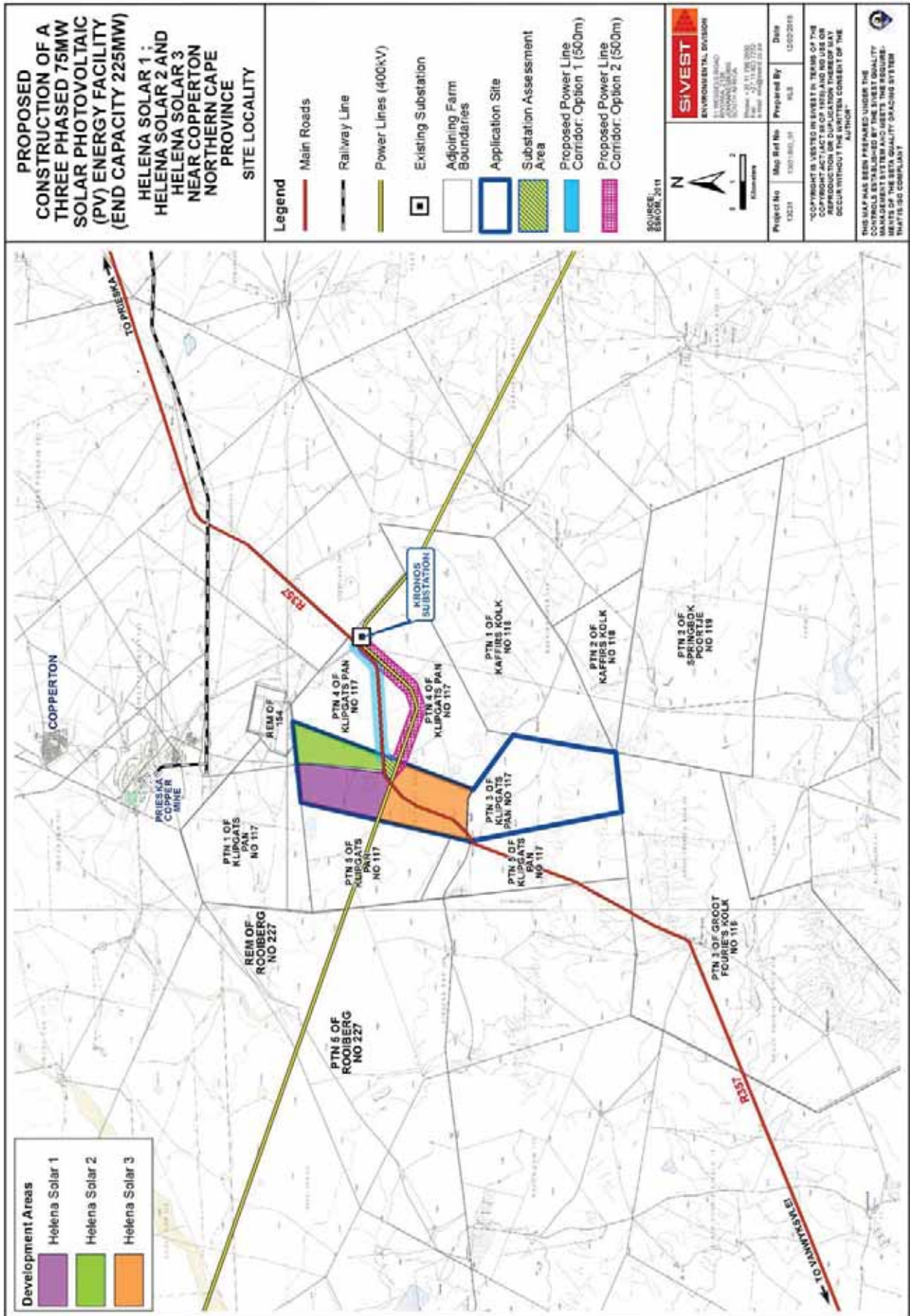

Figure 2: Typical Solar PV Panel.

Figure 3: PV electricity generation and conversion process.

Figure 1: Locality Map /



EIA PROCESS

What is an EIA?

An EIA is a process of collecting, organising, analysing, interpreting and communicating information that is relevant to consider a particular environmental application.

EIAs are used by planning authorities/developers to obtain an independent and objective view of the potential environmental (biophysical and social) impacts that could arise during the construction and operation of the proposed development. This information needs to provide the Competent Authority with a sound basis for their decision-making.

Legal requirements

According to the NEMA as amended, an EIA process is required for the proposed development as several listed activities are triggered by each proposed 75MW export capacity solar PV energy facility, which require investigation. They include the following:

- GN R 544: Item 10, 11, 18, 22, 26, 38, 39, 47;
- GN R 545: Item 1, 15; and
- GN R 546: Item 4, 12, 13, 14, 16 and 19.

The EIA process that will be followed is illustrated in Figure 5 .

Competent authority

The Competent Authority for this proposed project is the DEA.

Environmental issues to be investigated during the EIA

Various environmental parameters have been identified that will require investigation for the proposed development. These are listed in Table 1 below.

SKILL	NAME
Biodiversity	David Hoare Consulting – David Hoare
Avifauna	Chris van Rooyen Consulting – Chris van Rooyen
Surface Water	SiVEST – Shaun Taylor, Alistair Fyfe
Agricultural Potential and Soils	Agricultural Research Council: Institute for Soil, Climate and Water – Garry Paterson
Heritage and Palaeontology	PGS – Wouter Fourie Natura Viva – John Almond
Visual	SiVEST – Andrea Gibb, Kerry Schwartz
Social	Urban Econ – Elena Broughton

Table 1. List of specialists and specialist studies to be undertaken for the proposed development

Alternatives

In terms of the EIA regulations, feasible and reasonable alternatives are required to be considered through the EIA process. These alternatives can include the following:

- the property on which or location where it is proposed to undertake the activity;
- the type of activity to be undertaken;
- the design or layout of the activity;
- the technology to be used in the activity;
- the operational aspects of the activity; and
- the option of not implementing the activity.

Layout alternatives, power line alignment alternatives and the no-go alternative will be considered in the impact phase of the EIA process.

THE PUBLIC PARTICIPATION PROCESS

Public participation is the cornerstone of any EIA, as it will be for this proposed project. The principles of NEMA govern many aspects of EIAs, including public participation.

The key objective of public participation during this EIA will be to provide I&APs with sufficient and relevant information and to conduct a transparent consultation process on an on-going basis, in order to ensure effective participation throughout the EIA process.

As part of this public participation process you will also be provided with the opportunity to comment on the environmental findings as per the EIA reports (Scoping and Impact Assessment), which will be made available for public review and comment during the process.

It is important that relevant I&APs and Stakeholders are identified and involved in the public participation process from the outset of the proposed project. As a registered I&AP, you

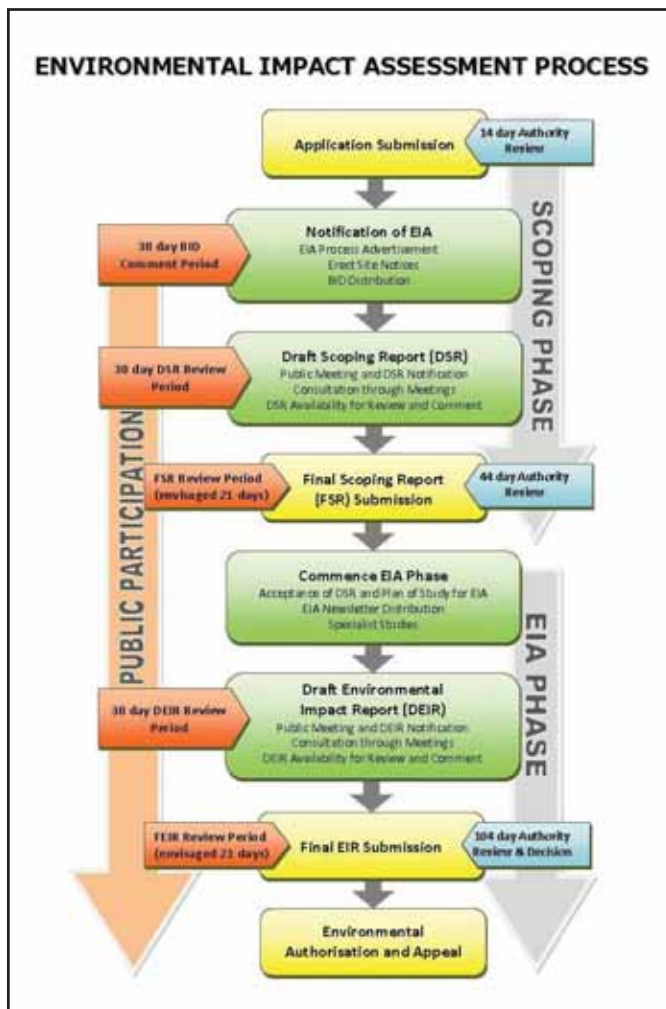

Figure 5: EIA process diagram.

will receive personal notifications, via post, fax, e-mail and/or sms (where applicable), notifying you of all documents available for comment, comment periods and upcoming meetings.

Your responsibilities as an I&AP

In terms of the EIA Regulations, your attention is drawn to your responsibilities as an I&AP:

- In order to participate in this EIA process, register yourself on the project database;
- Inform any other parties (neighbours, friends, colleagues, etc.) who may be interested and/or affected by the proposed project about the EIA process and encourage them to become involved; and
- Ensure that any comments regarding the proposed project are submitted within the timeframes that have been approved or set by DEA, or within any extension of a timeframe agreed to by the DEA and the applicant, BioTherm.

Our responsibilities as the independent EAP

In terms of the EIA Regulations, our responsibilities in the public consultation process include:

- Ensuring that sufficient information regarding this proposed project is made available to you, either through the BID or providing information as and when requested;
- Ensuring that you have an understanding of the proposed project to be able to comment informatively, and to enable you to submit any concern in an informed manner; and
- Ensuring that the following actions are taken upon receiving any comments/queries/issues:
 - o The contact details provided by you will be entered into the project database and that you will be sent all further information releases;
 - o If you send us queries or comments, we will respond in writing (either via email or within the comments and response report);

How to become involved

If you wish to register as an I&AP, you can do so by the following methods:

- Respond (by phone, fax or e-mail) to our invitation for your participation, which has been advertised in the printed media;
- Mail, fax or e-mail the attached Registration and Comment Form to SiVEST;
- Attend the meetings to be held during the course of the project. Should you register as an I&AP you will automatically be invited to attend these meetings;
- Contact us telephonically should you have a query, comment or require further project information; and
- Submit comments on the draft Scoping Report and/or the draft Environmental Impact Report within the review periods that will be stipulated in your personalised letter.

If you consider yourself an I&AP for this proposed project, we urge you to make use of the opportunities created by the public participation process to become actively involved in the process and provide comment or concerns which affect and/or interest you, or about which you would like more information. Your input into this process forms a key part of the environmental studies and we would like to hear from you to obtain your views on the proposed project.

By completing and submitting the accompanying Registration and Comment Form, you automatically register yourself as an I&AP for this proposed project, ensuring that your comments and/or concerns raised regarding the proposed project will be noted and addressed. The public participation consultants will respond to all comments and queries received during the course of the project.

Please be informed that all relevant public documents can be downloaded from the SiVEST website.

SiVEST



We look forward to your contributions

Contact: Andrea Gibb or Lynsey Rimbault

 PO Box 2921, RIVONIA, 2128

 Phone: (011) 798 0600

 E-mail: andrea@sivest.co.za or lynsey@sivest.co.za

 Fax: (011) 803 7272

Website: www.sivest.co.za



LIST OF ACRONYMS

AC	Alternating Current
BID	Background Information Document
DC	Direct Current
DEA	Department of Environmental Affairs
EAP	Environmental Assessment Practitioner
EMPr	Environmental Management Programme
EIA	Environmental Impact Assessment
GW	Gigawatt
I&AP	Interested and/or Affected Party
Km	Kilometre
kV	Kilovolt
MW	Megawatt
NEMA	National Environmental Management Act, 1998 (Act No. 107 of 1998)
PV	Photovoltaic

OMGEWINGSIMPAKEVALUERING (OIE) EN OMGEWINGSBESTUURSPROGRAM (OBPr) VIR DIE VOORGESTELDE ONTWIKKELING VAN DRIE 75 MW FOTOVOLTAÏESE (FV) SONKRAGANLEGTE NABY COPPERTON, NOORD-KAAPROVINSIE

SiVEST



- HELENA SOLAR 1 – DO Verw. No.: 14/12/16/3/3/2/765
- HELENA SOLAR 2 – DO Verw. No.: 14/12/16/3/3/2/766
- HELENA SOLAR 3 – DO Verw. No.: 14/12/16/3/3/2/767

elektrisiteitstekorte, die groter vraag na elektrisiteit en ook die behoefte om meer volhoubare en omgewingsvriendelike

kraghulpbronne te vind, het Suid-Afrika 'n infrastruktuur-groei-program aangepak wat deur verskeie staatsinisiatiewe ondersteun word. Ten einde die langtermyn doelwit om 'n volhoubare, hernubare kragbedryf te verwesenlik, het die Departement van Energie 'n teiken gestel om teen 2030 17,8 GW hernubare krag by die finale kragverbruik te voeg. Hierdie teiken moet hoofsaaklik geproduseer word deur wind- en sonkrag, maar ook deur biomassa- en kleinskaal hidrokrags (DMH, 2003; GOP, 2010).

In antwoord op hierdie doelwit, doen BioTherm aan die hand om drie FV-sonkragaanlegte, elk met 'n uitvoervermoë van 75 MW, naby Copperton in die Noord-Kaapprovinsie op te rig. Die algehele doelwit van die projek is om elektrisiteit op te wek om in Eskom se nasionale kragrooster in te voer aan die hand van hernubare kragtegnologieë.

WAAROM SONKRAG GEBRUIK?

Die voordele van die gebruik van sonkrag sluit in:

- FV-sonkragaanlegte het die vermoë om grootskaal kommersiële krag te lewer;
- sonkrag is hernubaar, skoon en nie-besoedelend (kweekhuisgasse, ens.) en lewer geen neweprodukte (atmosferiese besoedelaars of termiese besoedeling) op wat skadelik vir die omgewing kan wees nie;

INLEIDING

BioTherm Energy (Edms.) Bpk. (hierna BioTherm genoem) stel die oprigting voor van 'n driefase fotovoltaïese (FV) sonkragaanleg met 'n totale uitvoervermoë van 225 MW, naby Copperton in die Noord-Kaapprovinsie. Die voorgestelde projek sal bestaan uit drie FV-sonkragaanlegte met 'n uitvoervermoë van 75 MW elk wat as Helena Solar 1, 2 en 3 sal bekendstaan.

Ingevolge die Regulasies op Omgewingsimpevaluerings (OIE-regulasies) wat ingevolge Artikel 24 en 24D van die Nasionale Wet op Omgewingsbestuur (Wet 107 van 1998) (NEMA) afgekondig is, word verskeie aspekte van die voorgestelde FV-sonkragaanlegte as gelyste aktiwiteite geag wat 'n impak op die omgewing kan hê en derhalwe vereis dit magtiging van die Nasionale Departement van Omgewingsake (DO) vóór die aanvang van sodanige aktiwiteite. Hoewel nuwe OIE-regulasies op 4 Desember 2014 afgekondig is en op 8 Desember 2014 in werking getree het (Staatskoerantnommer 38282), is die aansoekvorms vir die voorgestelde FV-sonkragaanlegte op 5 Desember 2014 by die DO ingedien vóór die 2014 OIE-regulasies in werking getree het. Kragtens Regulasie 53(1) van die 2014 OIE-regulasies, moet enige aansoeke wat ingevolge die vorige NEMA-regulasies ingedien is, onderneem word asof die vorige NEMA-regulasies nie herroep is nie. Derhalwe sal die OIE-proses ingevolge die 2010 OIE-regulasies onderneem word, wat in vier Staatskennisgewings (R543, R544,

R545 en R546) vervat is wat op 18 June 2010 afgekondig en op 2 Augustus 2010 in werking getree het.

BioTherm het SiVEST SA (Edms.) Bpk. (hierna SiVEST genoem) derhalwe as die onafhanklike omgewings-evaluerings-praktisyn (OEP) aangestel om die nodige OIE-proses ingevolge NEMA te onderneem.

DOEL VAN HIERDIE DOKUMENT

Die doel van hierdie Agtergrond-inligtingsdokument (AID) is om Belangstellende en/of Geaffekteerde Partye (B&GP's) in te lig oor die OIE-proses wat vir die voorgestelde ontwikkeling onderneem word. Benewens die verskaffing van inligting oor die voorgestelde projek en die OIE-proses, sal hierdie AID ook aan B&GP's die geleentheid bied om:

- die voorgestelde projek beter te verstaan ten einde kommentaar te lewer en knelpunte te opper;
- die OIE-proses te verstaan ten einde doeltreffend daaraan te kan deelneem;
- voorstelle te maak om die voorgestelde projek te verbeter;
- kommentaar te lewer oor die spesialisstudies wat onderneem gaan word; en
- plaaslike kennis by te dra.

AGTERGROND BETREFFENDE DIE VOORGESTELDE PROJEK

Ter ondersteuning van die behoefte om oplossings te vind vir die huidige

- FV-sonkragaanlegte is oor die algemeen baie gepas vir plattelandse omgewings en derhalwe het dit 'n kleiner impak op landbou in vergelyking met ander kragopwekkingsopsies; FV-sonkragaanlegte kan ook bydra tot ekonomiese groei in hierdie gebiede;
- sonkrag is een van die goedkoopste maniere om elektrisiteit op te wek;

- plaaslike kragproduksie verminder verliese deur transmissielyn wat gepaardgaan met die oorbring van elektrisiteit oor lang afstande;
- FV-sonkragaanlegte verbeter Suid-Afrika se kragsekerheid, wat sodoende afhanklikheid van fossielbrandstowwe verminder.

PROJEKLIIGING

Die voorgestelde projek is in die Noord-Kaapprovinsie, sowat 9 km suid van Copperton geleë. Dit is in die Siyathemba Plaaslike Munisipaliteit geleë wat deel vorm van die Pixley ka Seme Distriksmunisipaliteit.

Die projek sluit die volgende plase in:

- Gedeelte 3 van die plaas Klipgatspan No. 117 (sonkragaanlegte); en

- Gedeelte 4 van die plaas Klipgatspan No. 117 (kraglyn).

Die projekterrein naby Copperton is geïdentifiseer deur vooraf-bedryfbaarheidstudies wat BioTherm op grond van 'n beraming van die sonkraghulpbron asook weer, stof, grond en oppervlakalbedo onderneem het. 'n Roosterkonneksie en die beskikbaarheid van grond was ook belangrike aanvanklike oorwegings. Die aansoekterrein vir die drie voorgestelde FV-sonkragaanlegte word op die liggingskaart hieronder (Figuur 1) aangedui.

TEGNIÛSE BESONDERHEDE

Op hierdie stadium word aan die hand gedoen dat die komponente van elke FV-sonkragaanleg sal bestaan uit:

- sowat 300 000 FV-panele met 'n totale uitvoervermoë van 75 MW;
- panele, wat hetsy vaste-as gemonteerde of enkelas naspooroplossings sal wees (Figuur 2), en hetsy kristallien-silikon of dun filmtegnologie sal wees;
- 'n skakelstasie, met die transformators vir spanningsverhoging van medium na hoë spanning;
- panele, wat in stringe aan wisselrigters gekonnekteer sal wees; vir 'n aanleg van 75 MW sal 2 MW wisselrigterstasies normaalweg gebruik word wat in omhulsels bestaan uit 2 x 1 MW wisselrigters en 1 x 2 MVA transformator sal gebruik; derhalwe sal sowat 43 wisselrigterstasies regdeur die terrein benodig word;
- wisselrigters wat die panele se GS-krag in WS-krag sal omsit waarna die spanning in die transformators verhoog sal word na hoogstens 22 kV tot 33 kV (mediumspanning) (Figuur 3);
- 22 kV tot 33 kV kables wat ondergronds in die aanleg tot by 'n sentrale punt sal loop voor dit by die

substasie op die terrein sal invoer, waar die spanning normaalweg tot 132 kV verhoog sal word;

- 'n roosterkonneksie met die Kronos Substasie;
- 'n kraglyn van minder as 275 kV vanaf die substasie op die terrein tot by die Kronos Substasie oor 'n afstand van sowat 4 km; 'n stapelwerf vir die tydelike berging van materiale tydens die konstruksiebedrywighede;
- toegangspaaie en interne paaie;
- die oprigting van 'n parkeerterrein en 'n heining om die projek; 'n administrasie-, kontrole- en pakhuisgeboue

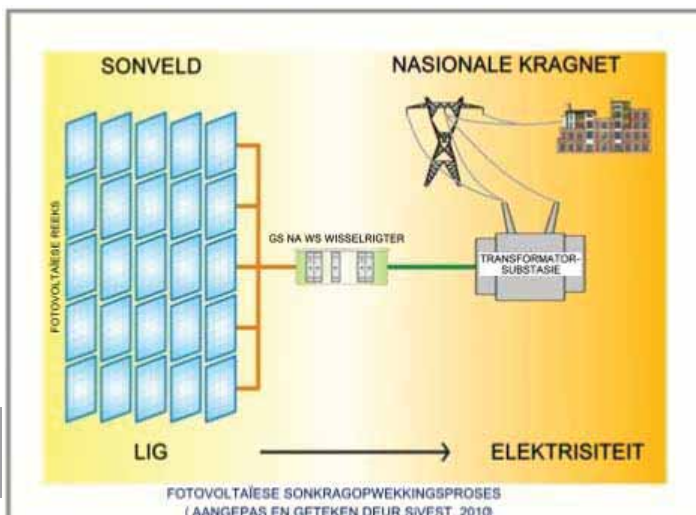

Figuur 2: Tipiese FV-sonkragpaneel

Figuur 3: FV-elektrisiteits opwekking en omskakelingsproses.

OIE-PROSES

Wat is 'n OIE?

'n OIE is 'n proses waardeur inligting wat tersaaklik is vir die oorweging van 'n betrokke omgewingsaansoek versamel, georganiseer, ontleed, vertolk en gekommunikeer word.

OIE's word deur beplanningsowerhede/ontwikkelaars gebruik om 'n onafhanklike en objektiewe siening van die potensiële omgewingsimpakte (biofisies en maatskaplik) te verkry wat tydens die oprigting en bedryf van die voorgestelde ontwikkeling kan opduik. Hierdie inligting moet die Bevoegde Owerheid 'n konkrete grondslag vir hul besluitneming bied.

Wetlike vereistes

Ooreenkomstige NEMA, soos gewysig, moet 'n OIE-proses vir die voorgestelde ontwikkeling onderneem word aangesien elk van die voorgestelde FV-sonkragaanlegte met 'n uitvoervermoë van 75 MW elk aanleiding tot verskeie gelyste aktiwiteite gee, wat ondersoek moet word.

Dit sluit in

- Staatskennisgewing R544: Item 10, 11, 18, 22, 26, 38, 39, 47;
- Staatskennisgewing R545: Item 1 en 15; en
- Staatskennisgewing R546: Item 4, 12, 13, 14, 16 en 19.

Die OIE-proses wat gevolg sal word, word in Figuur 5 hieronder uiteengesit.

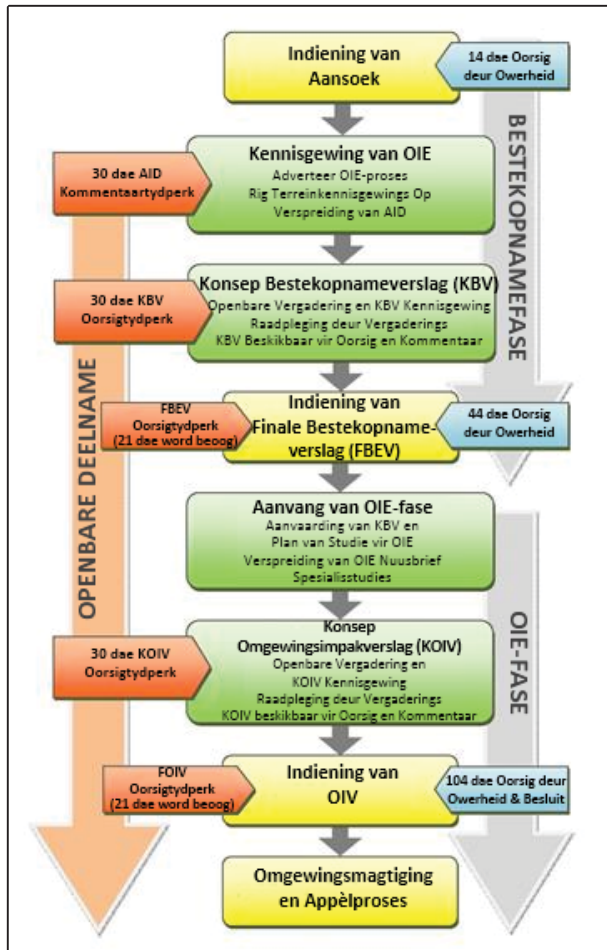

Figuur 5: Diagram van OIE-proses

Bevoegde Owerheid

Die DO is die bevoegde owerheid vir hierdie voorgestelde projek.

Omgewingsvraagstukke wat tydens die OIE ondersoek gaan word

Verskeie omgewingsparameters is vir die voorgestelde ontwikkeling geïdentifiseer wat ondersoek sal moet word. Dit word in Tabel 1 hieronder gelys.

VAARDIGHEID	NAAM
Biodiversiteit	David Hoare Consulting – David Hoare
Avifauna	Chris van Rooyen Consulting – Chris van Rooyen
Oppervlakwater	SiVEST – Shaun Taylor, Alistair Fyfe
Grondsoorte en Landboupotensiaal	Landbounavorsingsraad: Instituut vir Grond, Klimaat en Water – Garry Paterson
Erfenis en Paleontologie	PGS – Wouter Fourie
Visueel	SiVEST – Andrea Gibb, Kerry Schwartz
Maatskaplik	Urban Econ – Elena Broughton

Tabel 1: Lys van spesialiste en spesialisstudies wat vir die voorgestelde ontwikkeling onderneem word

Alternatiewe

Ingevolge die OIE-regulasies moet OIE-proses oorweging aan bedryfbare en billike alternatiewe skenk.

- Hierdie alternatiewe kan insluit die:
- eiendom waarop of plek waar die onderneming van die aktiwiteit voorgestel word;
- soort aktiwiteit wat onderneem gaan word;
- ontwerp of uitleg van die aktiwiteit;
- tegnologie wat in die aktiwiteit gebruik gaan word;
- bedryfsaspekte van die aktiwiteit; en
- opsie om nie die aktiwiteit in werking te stel nie.

Alternatiewe rondom uitleg, kraglynbelnying en die verbode alternatief sal in die impakfase van die OIE-proses oorweging geniet.

DIE OPENBARE DEELNAMEPROSES

Openbare deelname is die hoeksteen van enige OIE, soos ook die geval is vir hierdie voorgestelde projek. Die beginsels van NEMA beheer baie aspekte van OIE's, insluitend openbare deelname. Die hoofdoel van openbare deelname gedurende hierdie OIE sal wees om B&GP's van genoegsame en tersaaklike inligting te voorsien en om deursigtige oorlegpleging op 'n deurlopende basis te onderneem ten einde doeltreffende deelname regdeur die OIE-proses te verseker. As deel van hierdie openbare deelnameproses sal u ook die geleentheid kry om kommentaar te lewer oor die omgewingsbevindinge ingevolge die OIE-verslae (Bestekopname en Impakevaluering), wat tydens die proses beskikbaar gestel gaan word vir openbare oorsig en kommentaar.

Dit is belangrik dat tersaaklike B&GP's en Belanghebbendes uit die staanspoor van die voorgestelde projek geïdentifiseer

en by die openbare deelnameproses betrek word. As 'n geregistreerde B&GP sal u persoonlike kennisgewings per pos, faks, e-pos en/of sms (waar van toepassing) ontvang wat u in kennis sal stel van alle dokumente wat beskikbaar is vir kommentaar, die kommentaartydperke en toekomstige vergaderings.

U verantwoordelikhede as 'n B&GP

Kragtens die OIE-regulasies word u aandag gevestig op u verantwoordelikhede as 'n B&GP:

- Ten einde aan hierdie OIE-proses deel te neem, moet u uself op die projek se databasis registreer.
- U moet enige ander partye (bure, vriende, kollegas, ens.) wat mag belangstel en/of deur die voorgestelde projek geraak kan word, in kennis van die OIE-proses en hulle aanmoedig om betrokke te raak.
- U moet toesien dat enige kommentaar rakende die voorgestelde projek binne die tydsraamwerke ingedien word wat deur die DO goedgekeur of gestel is, of binne enige verlenging van 'n tydsraamwerk waarvoor tussen die DO en die applikant, BioTherm, ooreengekom is.

Ons verantwoordelikhede as die onafhanklike OEP

Ingevolge die OIE-regulasies, sluit ons verantwoordelikhede in die openbare raadplegingsproses die volgende in:

- Ons moet toesien dat voldoende inligting betreffende hierdie voorgestelde projek aan u beskikbaar gestel word, hetsy deur die AID of deur inligting te verskaf soos en wanneer dit versoek word.
- Ons moet toesien dat u 'n begrip van die voorgestelde projek het ten einde ingeligte kommentaar te kan lewer en om u in staat te stel om enige knelpunt op ingeligte wyse in te dien.
- Ons moet toesien dat die volgende stappe geneem word met ontvangs van enige kommentaar/navraag/vraagstuk:
 - o Die kontakbesonderhede wat u verskaf moet in die projek se databasis ingevoer word en u sal alle verdere vrystellings van inligting ontvang.
 - o Indien u vir ons navrae of kommentaar stuur, sal ons skriftelik daarop reageer (hetsy per e-pos of in die kommentaar- en antwoordverslag).

Hoe om betrokke te raak

Indien u as 'n B&GP wil registreer, kan u dit doen deur die volgende metodes te volg:

- Deur te reageer (telefonies, per faks of e-pos) op ons uitnodiging vir u deelname, wat in die gedrukte media geadverteer is.
- Deur die aangehegte Registrasie- en Kommentaarvorm aan SiVEST te pos, te faks of te e-pos.
- Deur die vergaderings by te woon wat gedurende die verloop van die projek gehou sal word. indien u as 'n B&GP registreer, sal u outomaties uitgenooi word om hierdie vergaderings by te woon.
- Deur telefonies met ons in verbinding te tree indien u 'n navraag of kommentaar het of verdere projekinligting verlang.
- Deur kommentaar oor die konsep Bestekopnameverslag en/of die konsep Omgewingsimpakverslag binne die oorsigtydperke wat in u persoonlike skrywe gestipuleer sal wees, in te dien.

Indien u uself as B&GP vir hierdie voorgestelde projek ag, moedig ons u aan om gebruik te maak van die geleentheid wat deur die openbare deelnameproses geskep word om aktief by die proses betrokke te raak en kommentaar te lewer of daardie vraagstukke of knelpunte te opper wat u raak en/of waarin u belangstel en waarvoor u meer inligting verlang. U inset in hierdie proses vorm 'n belangrike deel van die omgewingstudies en ons hoor graag van u om u siening oor die voorgestelde projek in te win.

Deur die meegaande Registrasie- en Kommentaarvorm in te vul en in te dien, registreer u uself outomaties as 'n B&GP vir hierdie voorgestelde projek en verseker u dat kennis geneem sal word van die kommentaar en/of navrae wat u betreffende die voorgestelde projek opper. Die openbare deelnamekonsultante sal op alle kommentaar en navrae reageer wat tydens die verloop van die projek ontvang word.

Neem asseblief kennis dat alle tersaaklike publieke dokumente van SiVEST se webwerf afgelaai kan word.

SiVEST



Ons sien uit na u bydraes

Tree in verbinding met: Andrea Gibb of Lynsey Rimbault

Posbus 2921, RIVONIA, 2128

Tel: 011 798 0600

E-pos: andrag@sivest.co.za of lynseyr@sivest.co.za

Faks: 011 803 7272

Webwerf: www.sivest.co.za



LYS MET AKRONIEME

AID	Agtergrondinligtingsdokument
B&GP	Belangstellende en/of Geaffekteerde Party
DO	Departement van Omgewingsake
FV	Fotovoltaïes
GS	Gelykstroom
GW	Gigawatt
Km	Kilometer
kV	Kilovolt
MW	Megawatt
NEMA	Nasionale Wet op Omgewingsbestuur, 1998 (Wet 107 van 1998)
OBPr	Omgewingsbestuursprogram
OEP	Omgewingsevalueringspraktisyn
OIE	Omgewingsimpakevaluering
WS	Wisselstroom

EIA AND EMPr FOR THE PROPOSED DEVELOPMENT OF THREE 75MW SOLAR PHOTOVOLTAIC (PV) ENERGY FACILITIES NEAR COPPERTON, NORTHERN CAPE PROVINCE

- HELENA SOLAR 1 – DEA Ref No: 14/12/16/3/3/2/765
- HELENA SOLAR 2 – DEA Ref No: 14/12/16/3/3/2/766
- HELENA SOLAR 3 – DEA Ref No: 14/12/16/3/3/2/767

REGISTRATION AND COMMENT FORM

Accompanying Background Information Document: 18 February 2015



Public Participation Office



Andrea Gibb / Lynsey Rimbault
 SiVEST Environmental
 PO Box 2921, RIVONIA, 2128
Tel (011) 798 0600
Fax (011) 803 7272
Email andreag@sivest.co.za /
 lynseyr@sivest.co.za

Please complete by Thursday 19 March 2015, and return by post, fax or e-mail to the Public Participation Office (as above)

TITLE		FIRST NAME	
INITIALS		SURNAME	
ORGANISATION		EMAIL	
POSTAL ADDRESS			
		POSTAL CODE	
TEL NO		FAX NO	

REGISTRATION AS INTERESTED AND/OR AFFECTED PARTY (I&AP) (please circle applicable box)

Please formally register me as an interested and affected party (I&AP) so that I may receive further information and notifications during the EIA process	YES	NO
In terms of GNR 543 (2010 EIA regulations) I disclose below any direct business, financial, personal or other interest that I may have in the granting or rejection of the application for environmental authorisation (please use separate sheets if you wish):		

COMMENTS (please use separate sheets if you wish)

I suggest that the following issues of concern be investigated in the EIA:

.....

I suggest the following for the EIA process and / or the public participation process:

.....

Any other comments:

.....

Please contact the following colleagues/friends to register as I&APs for this EIA (name and contact details e.g. e-mail address):

.....

 Signature

THANK YOU FOR YOUR CONTRIBUTION

 Date

OIE EN OBPR VIR DIE VOORGESTELDE ONTWIKKELING VAN DRIE 75 MW FOTOVOLTAÏESE (FV) SONKRAGANLEGTE NABY COPPERTON, NOORD-KAAPROVINSIE

- HELENA SOLAR 1 – DO Verw. No.: 14/12/16/3/3/2/765
- HELENA SOLAR 2 – DO Verw. No.: 14/12/16/3/3/2/766
- HELENA SOLAR 3 – DO Verw. No.: 14/12/16/3/3/2/767

REGISTRASIE- EN KOMMENTAARVORM

Vergesel die Agtergrondinligtingsdokument: 18 Februarie 2015



Openbare Deelnamekantoor



Andrea Gibb / Lynsey Rimbault
 SiVEST Environmental
 Posbus 2921, RIVONIA, 2128
Tel: 011 798 0600
Faks: 011 803 7272
E-pos: andreag@sivest.co.za /
 lynseyr@sivest.co.za

Vul asseblief in teen Donderdag, 19 Maart 2015 en stuur dit per pos, faks of e-pos terug aan die Openbare Deelnamekantoor (soos hierbo).

TITEL		VOORNAAM	
VOORLETTERS		VAN	
INSTANSIE		E-POS	
POSADRES			
		POSKODE	
TEL NO.		FAKS NO.	

REGISTRASIE AS BELANGSTELLEDE EN/OF GEAFFEKTEERDE PARTY (B&GP) (omkring asseblief die toepaslike blokkie)

Registreer my asseblief formeel as 'n belangstellende en geaffekteerde party (B&GP) sodat ek verdere inligting en kennisgewings tydens die OIE-proses kan ontvang.	<input type="checkbox"/> JA	<input type="checkbox"/> NEE
Ingevolge Staatskenningsgewing R543 (2010 OIE-regulasies) maak ek hieronder enige regstreekse sake, finansiële, persoonlike of ander belang wat ek mag hê in die goedkeuring of afkeuring van die aansoek om omgewingsmagtiging bekend (gebruik gerus aparte bladsye indien u wil):		
.....		

KOMMENTAAR (gebruik gerus aparte bladsye indien u wil)

Ek stel voor dat die volgende knelpunte tydens die OIE ondersoek word:

.....

Ek stel die volgende vir die OIE-proses en/of die openbare deelnameproses voor:

.....

Enige ander kommentaar:

.....

Tree asseblief in verbinding met my onderstaande kollegas/vriende om as B&GP's vir hierdie OIE te registreer (naam en kontakbesonderhede, bv. e-posadres):

.....

 Handtekening

DANKIE VIR U BYDRAE

 Datum

Veronique Evans

From: Veronique Evans
Sent: 28 May 2015 04:47 PM
Cc: Lynsey Rimbault; Andrea Gibb
Subject: Three Proposed Helena Solar Photovoltaic Energy Facilities: DSR Comment Period Starting
Attachments: Helena Solar PV Plant DSR Comment Form rev 1 20 May 2015 LR - Combined.pdf

Tracking:	Recipient	Delivery	Read
	Lynsey Rimbault	Delivered: 2015/05/28 04:47 PM	
	Andrea Gibb	Delivered: 2015/05/28 04:47 PM	Read: 2015/05/29 06:44 AM
	'.'		
	'Carolyn Ah Shene-Verdoorn'		
	'JRM Alexander'		
	'Paul Avenant'		
	'Hettie B'		
	'Johan Badenhorst'		
	'Zak Barnard'		
	'Danie & Jomima Bernard'		
	'Amanda Bester'		
	'Koos Botha'		
	'Thomas Botha'		
	'Pilla Buis'		
	'Thoko Buthalezi'		
	'Francois Coetzee'		
	'Anneliza Collett'		
	'Rene De Kock'		
	'Sam Diokpala'		
	'Shaun Dyers'		
	'Suzanne Erasmus'		
	'Sam Fiff'		
	'Nico Fourie'		
	'Simon Gear'		
	'John Geeringh'		
	'Bradley Gibbons'		
	'Benjamin Brendon Hendricks'		
	'Alexia Hlengani'		
	'Hendrik Human'		
	'Johannes Human'		
	'S Human'		
	'Wynand Human'		
	'Jermaine Isaacs'		
	'Danielle Julies'		
	'Le-Waine Kakora'		
	'George Karsten'		

Recipient	Delivery	Read
'Albertha Kellerman'		
'Mere Kgampe'		
'Miriam Kibi'		
'Ernest Kubayi'		
'Justin Langfred'		
'Jenna Lavin'		
'Jack Maccollan'		
'Sindisile Madyo'		
'Ester Makungo'		
'Jacoline Mans'		
'Simpfiwe Masilela'		
'Sivemah Mdlokovama'		
'Chetna Mistry'		
'Thulani Mthombeni'		
'Danster Muggen'		
'Mashudu Mukoma'		
'Onwabile Ndzumo'		
'AG Nel'		
'Almarette Nieuwoudt'		
'Lorraine Nobela'		
'Piet Papier'		
'Ntsundeni Ravhogoni'		
'Irene Richardson'		
'Lynsey Rimbault'		
'Cheri Roberts'		
'Gerhardus Rudolph'		
'Gerrie Rudolph'		
'Hennie Schoeman'		
'Raylene Stadhouer'		
'Ivan Steenkamp'		
'Lizell Stoh'		
'Ertjies Taljaart'		
'Andrew Timothy'		
'Adriaan Tiplady'		
'Heleen van den Heever'		
'Anton van Heerden'		
'William van Staden'		
Lynsey Rimbault		
'Coenie Viljoen'		
'Ronelle Visagie'		
'Eden William'		
'Keith Woolf'		
'Mandisa Yawa'		

***** Please note that this email was sent from a NO REPLY email address. Please do not reply to this address as it is an unmonitored email account. *****

Dear Interested and/or Affected Party

ENVIRONMENTAL IMPACT ASSESSMENT (EIA) AND ENVIRONMENTAL MANAGEMENT PROGRAMME (EMPr) FOR THREE HELENA 75MW SOLAR PHOTOVOLTAIC (PV) ENERGY FACILITIES NEAR COPPERTON, NORTHERN CAPE PROVINCE

DEA Ref. HELENA SOLAR 1: 14/12/16/3/3/2/765
 HELENA SOLAR 2: 14/12/16/3/3/2/766
 HELENA SOLAR 3: 14/12/16/3/3/2/767

We would like to take this opportunity to inform you that, in accordance with the National Environmental Management Act (NEMA), the Draft Scoping Reports (DSRs) will be available for public comment and review as from **Thursday 28 May 2015 to Monday 29 June 2015** (end of business day). A DSR comment form is attached to this correspondence for your perusal. Should you wish to receive an electronic copy of the DSRs (CD) please forward your request in writing to us. Hard copies of the DSRs can be reviewed at any of the following public places:

VENUE	STREET ADDRESS	HOURS	CONTACT NO
Elizabeth Vermeulen Public Library	Corner Victoria Street and Steward Street, Prieska	Mondays- Fridays 08h45 – 16h15 Saturday 08h00 – 13h00	053 353 5300/ 053 353 5305

The reports are also available on SiVEST's website: <http://www.sivest.co.za/>, then browse to the folder '13031 Helena Solar PV EIA'.

Beste Belangstellende en/of Geaffekteerde Party

OMGEWINGSIMPAKEVALUERING (OIE) EN OMGEWINGSBESTUURSPROGRAM (OBPr) VIR DIE DRIE HELENA FOTOVOLTAÏESE ENERGIE FASILITEITE NABY COPPERTON, NOORD-KAAPROVINSIE

DO OIE Verw. No.: HELENA SOLAR 1: 14/12/16/3/3/2/765
 HELENA SOLAR 2: 14/12/16/3/3/2/766
 HELENA SOLAR 3: 14/12/16/3/3/2/767

Graag maak ons van hierdie geleentheid gebruik om u in te lig dat, ingevolge die Nasionale Wet op Omgewingsbestuur (NEMA), die Konsep Bestekopnameverslae beskikbaar sal wees vir openbare kommentaar en oorsig vanaf **Donderdag, 28 Mei 2015 tot Maandag, 29 Junie 2015** (teen sluitingstyd). Sou u graag 'n elektroniese kopie van die Konsep Bestekopnameverslae op CD wil ontvang, kan u dit skriftelik by ons aanvra. Gedrukte eksemplare van die Konsep Bestekopnameverslae sal ook by die volgende openbare plek beskikbaar wees vir besigtiging:

PLEK	STRAATADRES	KANTOOR URE	KONTAKNO.
Elizabeth Vermeulen Openbare Biblioteek	Hoek van Victoriastraat en Stewardstraat, Prieska	Maandae- Vrydae 08h45 – 16h15 Saterdag 08h00 – 13h00	053 353 5300/ 053 353 5305

Die Verslae is ook op SiVEST se webtuiste beskikbaar: <http://www.sivest.co.za/>, klik dan op die legger '13031 Helena Solar PV EIA'.

Kind Regards

Andrea Gibb (B.Sc. Landscape Architecture; B.Sc.(Hons) Environmental Management)

Environmental Practitioner and Visual Specialist

SiVEST Environmental Division



SiVEST is a Level 3 BBBEE Contributor



Direct +27 11 798 0638 **Tel** +27 11 798 0600 **fax** +27 11 803 7272 **cell** +27 72 587 6  **email** andreag@sivest.co.za **website** www.sivest.co.za

Consulting Engineers - Project Managers - Environmental Consultants - Town and Regional Planners
Durban - Johannesburg - Pietermaritzburg - Richards Bay - Ladysmith - Cape Town - Harare (Zimbabwe)

Your reference:

Our reference: 13031

Date: 28 March 2015

Dear Interested and/or Affected Party

**ENVIRONMENTAL IMPACT ASSESSMENT (EIA) AND ENVIRONMENTAL MANAGEMENT PROGRAMME (EMPr)
FOR THE THREE HELENA SOLAR PHOTOVOLTAIC (PV) ENERGY FACILITIES NEAR COPPERTON,
NORTHERN CAPE PROVINCE**

DEA Ref. HELENA SOLAR 1: 14/12/16/3/3/2/765
HELENA SOLAR 2: 14/12/16/3/3/2/766
HELENA SOLAR 3: 14/12/16/3/3/2/767

• **AVAILABILITY OF DRAFT SCOPING REPORT FOR PUBLIC REVIEW**

We would like to take this opportunity to inform you that, in accordance with the National Environmental Management Act (NEMA), the Draft Scoping Reports (DSRs) will be available for public comment and review as from **Thursday 28 May 2015** to **Monday 29 June 2015** (end of business day). A DSR comment form is attached to this correspondence for your perusal. Should you wish to receive an electronic copy of the DSRs (CD) please forward your request in writing to us. Hard copies of the DSRs can be reviewed at any of the following public places:

VENUE	STREET ADDRESS	HOURS	CONTACT NO
Elizabeth Vermeulen Public Library	Corner of Victoria Street and Steward Street, Prieska	Mondays- Fridays 08h45 – 16h15 Saturday 08h00 – 13h00	053 353 5300/ 053 353 5305

The reports are also available on SiVEST's website: <http://www.sivest.co.za/>, then browse to the folder '13031 Helena Solar PV EIA'.

We would like to thank you in anticipation of your active and meaningful contribution to the EIA and Public Participation process.

Kind Regards



Andrea Gibb
Environmental Consultant
SiVEST Environmental Division

Documents attached: DSR Comment Form

U verwysing:

Ons verwysing: 13031

Datum: 28 Maart 2015

Beste Belangstellende en/of Geaffekteerde Party

OMGEWINGSIMPAKEVALUERING (OIE) EN OMGEWINGSBESTUURSPROGRAM (OBPr) VIR DIE DRIE HELENA FOTOVOLTAIESE ENERGIE FASILITEITE NABY COPPERTON, NOORD-KAAPROVINSIE

DO OIE Verw. No.: HELENA SOLAR 1: 14/12/16/3/3/2/765
HELENA SOLAR 2: 14/12/16/3/3/2/766
HELENA SOLAR 3: 14/12/16/3/3/2/767

• **UITNODIGING OM KOMENTAAR TE LEWER OP DIE KONSEP BESTEKOPNAMEVERSLAG**

Graag maak ons van hierdie geleentheid gebruik om u in te lig dat, ingevolge die Nasionale Wet op Omgewingsbestuur (NEMA), die Konsep Bestekopnameverslae beskikbaar sal wees vir openbare kommentaar en oorsig vanaf **Donderdag, 28 Mei 2015** tot **Maandag, 29 Junie 2015** (teen sluitingstyd). Sou u graag 'n elektroniese kopie van die Konsep Bestekopnameverslae op CD wil ontvang, kan u dit skriftelik by ons aanvra. Gedrukte eksemplare van die Konsep Bestekopnameverslae sal ook by die volgende openbare plek beskikbaar wees vir besigtiging:

PLEK	STRAATADRES	KANTOOR URE	KONTAKNO.
Elizabeth Vermeulen Openbare Biblioteek	Hoek van Victoriastraat en Stewardstraat, Prieska	Maandae- Vrydae 08h45 – 16h15 Saterdag 08h00 – 13h00	053 353 5300/ 053 353 5305

Die Verslae is ook op SiVEST se webtuiste beskikbaar: <http://www.sivest.co.za/>, klik dan op die legger '13031 Helena Solar PV EIA'.

Ons moedig u bywoning en deelname by die Publiekevergadering aan en dank u byvoorbaat vir u aktiewe en betekenisvolle bydrae tot die OIS-proses.

Vriendelike groete



Andrea Gibb
Omgewingskonsultant
SiVEST Omgewingsafdeling

Ingeslote Dokumente: Komentaarvorm

Veronique Evans

From: Veronique Evans
Sent: 28 May 2015 04:02 PM
To: Andrea Gibb; Lynsey Rimbault
Cc: 'JRM Alexander'; 'Paul Avenant'; 'Amanda Bester'; 'Thoko Buthalezi'; 'Francois Coetzee'; 'Shaun Dyers'; 'Suzanne Erasmus'; 'Sam Fiff'; 'Simon Gear'; 'John Geeringh'; 'Bradley Gibbons'; 'Johan Koegelenberg'; 'Sindisile Madyo'; 'Ester Makungo'; 'Jacoline Mans'; 'Simphiwe Masilela'; 'Thulani Mthombeni'; 'Onwabile Ndzumo'; 'Jasper Nieuwoudt'; 'Lorraine Nobela'; 'Hennie Schoeman'; 'Gert Steenkamp'; 'Ivan Steenkamp'; 'Lizell Stoh'; 'Andrew Timothy'; 'Adriaan Tiplady'; 'Heleen van den Heever'; 'Ronelle Visagie'
Subject: Helena Solar PV Energy Facilities DSR Comment Period Starting: Distribution to Organs of State

Tracking:	Recipient	Delivery	Read
	Andrea Gibb	Delivered: 2015/05/28 04:42 PM	Read: 2015/05/29 06:44 AM
	Lynsey Rimbault	Delivered: 2015/05/28 04:42 PM	Read: 2015/05/28 04:44 PM
	'JRM Alexander'		
	'Paul Avenant'		
	'Amanda Bester'		
	'Thoko Buthalezi'		
	'Francois Coetzee'		
	'Shaun Dyers'		
	'Suzanne Erasmus'		
	'Sam Fiff'		
	'Simon Gear'		
	'John Geeringh'		
	'Bradley Gibbons'		
	'Johan Koegelenberg'		
	'Sindisile Madyo'		
	'Ester Makungo'		
	'Jacoline Mans'		
	'Simphiwe Masilela'		
	'Thulani Mthombeni'		
	'Onwabile Ndzumo'		
	'Jasper Nieuwoudt'		
	'Lorraine Nobela'		
	'Hennie Schoeman'		
	'Gert Steenkamp'		
	'Ivan Steenkamp'		
	'Lizell Stoh'		
	'Andrew Timothy'		
	'Adriaan Tiplady'		
	'Heleen van den Heever'		
	'Ronelle Visagie'		

***** Please note that this email was sent from a NO REPLY email address. Please do not reply to this address as it is an unmonitored email account. *****

Dear Stakeholder,

ENVIRONMENTAL IMPACT ASSESSMENT (EIA) FOR THE PROPOSED CONSTRUCTION OF THE THREE HELENA PHOTOVOLTAIC (PV) ENERGY FACILITIES NEAR COPPERTON, NORTHERN CAPE PROVINCE

**DEA Ref No: HELENA SOLAR 1: 14/12/16/3/3/2/765
HELENA SOLAR 2: 14/12/16/3/3/2/766
HELENA SOLAR 3: 14/12/16/3/3/2/767**

SiVEST is in the process of undertaking the Environmental Impact Assessment (EIA) for the proposed construction of the three Helena Solar Photovoltaic (PV) Energy Facilities near Copperton, Northern Cape Province.

We would like to take this opportunity to inform you that, in accordance with the National Environmental Management Act (NEMA), the Draft Scoping Reports (DSR) will be made available for public comment and review as from **Thursday 28 May 2015 to Monday 29 June 2015** (end of business day).

The three DSRs can be accessed at the SiVEST website at <http://www.sivest.co.za/Download>. Additionally, an electronic copy (on CD) of the DSRs as well as the accompanying appendices has also been posted to you. We kindly request that you submit your comments to Public Participation Office at the below details, on or before **Monday 29 June 2015** (end of business day). In terms of section 56 (7) of the Environmental Impact Assessment Regulations (as amended), under Government Notices No R543, comments from state departments will be accepted until **Thursday 09 July 2015** (end of business day). SiVEST will forward any comments received after the public comment and review period directly to the relevant case officer at the Department of Environmental Affairs (DEA).

Should you have any questions or queries please do not hesitate to contact us at:

Andrea Gibb
PO BOX 2921, Rivonia, 2128
Tel – (011) 798 0600
Fax – (011) 803 7272
Email – andrea@sivest.co.za

Yours sincerely,

Kind Regards

Andrea Gibb (B.Sc. Landscape Architecture; B.Sc.(Hons) Environmental Management)

Environmental Practitioner and Visual Specialist

SiVEST Environmental Division



SiVEST is a Level 3 BBBEE Contributor

Direct +27 11 798 0638 Tel +27 11 798 0600 fax +27 11 803 7272 cell +27 72 587 6525
email andrea@sivest.co.za website www.sivest.co.za



Consulting Engineers - Project Managers - Environmental Consultants - Town and Regional Planners
Durban - Johannesburg - Pietermaritzburg - Richards Bay - Ladysmith - Cape Town - Harare (Zimbabwe)

Veronique Evans

From: Veronique Evans
Sent: 07 July 2015 04:44 PM
To: Andrea Gibb; Lynsey Rimbault
Cc: 'Mashudu Marubini'; 'makungoe@dws.gov.za'; 'sindisile.madyo@yahoo.com'; 'sindisile.excellent.madyo@gmail.com'; 'mmsec@siyathemba.gov.za'; 'gsteenkamp@ncpg.gov.za'; 'Jasper Nieuwoudt'; Timothy Andrews (ratha.timothy@gmail.com); 'Ivan Steenkamp'; 'ivandrea@mweb.co.za'; 'strohl@caa.co.za'; 'hennie.schoeman@transnet.net'; 'sam.fiff@transnet.net'; 'koegelenbergj@sentech.co.za'; 'bradleyg@ewt.org.za'; 'ronellev@ewt.org.za'; 'advocacy@birdlife.org.za'
Subject: FW: Helena Solar PV Energy Facilities DSR Comment Period Starting: Distribution to Organs of State
Attachments: 13031 BID (ENG) FEB 2015.pdf; 13031 BID (AFR) FEB 2015.pdf; Helena PV Invite Letter Rev 1 10Feb2015 AG.PDF; Helena PV Invite Letter Rev 1 10Feb2015 AG Afr.pdf; Helena PV BID Reg Comm Form Rev 1_10Feb2015 AG.PDF; Helena PV BID Reg Comm Form Rev 1_10Feb2015 AG Afr.pdf

Good Day,

SIVEST sent the application for the proposed development of the three Helena 75MW Solar PV Energy Facilities near Copperton to your Department on 28 May 2015 for comment (refer to the email below). Please can you advise if comments will be submitted to us for inclusion in the Final EIA Report.

We would like to inform you that, the comment period for state departments has ended and you are advised to send your comments to us before Wednesday 08 June 2015.

Kind Regards

Andrea Gibb (B.Sc. Landscape Architecture; B.Sc.(Hons) Environmental Management)
Environmental Practitioner and Visual Specialist
SIVEST Environmental Division



SIVEST is a Level 3 BBBEE Contributor

Direct +27 11 798 0638 Tel +27 11 798 0600 fax +27 11 803 7272 cell +27 72 587 6525
email andreaq@sivest.co.za website www.sivest.co.za



Consulting Engineers - Project Managers - Environmental Consultants - Town and Regional Planners
Durban - Johannesburg - Pietermaritzburg - Richards Bay - Ladysmith - Cape Town - Harare (Zimbabwe)

From: Veronique Evans
Sent: 28 May 2015 04:02 PM
To: Andrea Gibb; Lynsey Rimbault
Cc: 'JRM Alexander'; 'Paul Avenant'; 'Amanda Bester'; 'Thoko Buthalezi'; 'Francois Coetzee'; 'Shaun Dyers'; 'Suzanne Erasmus'; 'Sam Fiff'; 'Simon Gear'; 'John Geeringh'; 'Bradley Gibbons'; 'Johan Koegelenberg'; 'Sindisile Madyo'; 'Ester Makungo'; 'Jacoline Mans'; 'Simphiwe Masilela'; 'Thulani Mthombeni'; 'Onwabile Ndzumo'; 'Jasper Nieuwoudt'; 'Lorraine Nobela'; 'Hennie Schoeman'; 'Gert Steenkamp'; 'Ivan Steenkamp'; 'Lizell Stoh'; 'Andrew Timothy'; 'Adriaan Tiplady'; 'Heleen van den Heever'; 'Ronelle Visagie'
Subject: Helena Solar PV Energy Facilities DSR Comment Period Starting: Distribution to Organs of State

***** Please note that this email was sent from a NO REPLY email address. Please do not reply to this address as it is an unmonitored email account. *****

Dear Stakeholder,

ENVIRONMENTAL IMPACT ASSESSMENT (EIA) FOR THE PROPOSED CONSTRUCTION OF THE THREE HELENA PHOTOVOLTAIC (PV) ENERGY FACILITIES NEAR COPPERTON, NORTHERN CAPE PROVINCE

**DEA Ref No: HELENA SOLAR 1: 14/12/16/3/3/2/765
HELENA SOLAR 2: 14/12/16/3/3/2/766
HELENA SOLAR 3: 14/12/16/3/3/2/767**

SiVEST is in the process of undertaking the Environmental Impact Assessment (EIA) for the proposed construction of the three Helena Solar Photovoltaic (PV) Energy Facilities near Copperton, Northern Cape Province.

We would like to take this opportunity to inform you that, in accordance with the National Environmental Management Act (NEMA), the Draft Scoping Reports (DSR) will be made available for public comment and review as from **Thursday 28 May 2015 to Monday 29 June 2015** (end of business day).

The three DSRs can be accessed at the SiVEST website at <http://www.sivest.co.za/Download>. Additionally, an electronic copy (on CD) of the DSRs as well as the accompanying appendices has also been posted to you. We kindly request that you submit your comments to Public Participation Office at the below details, on or before **Monday 29 June 2015** (end of business day). In terms of section 56 (7) of the Environmental Impact Assessment Regulations (as amended), under Government Notices No R543, comments from state departments will be accepted until **Thursday 09 July 2015** (end of business day). SiVEST will forward any comments received after the public comment and review period directly to the relevant case officer at the Department of Environmental Affairs (DEA).

Should you have any questions or queries please do not hesitate to contact us at:

Andrea Gibb
PO BOX 2921, Rivonia, 2128
Tel – (011) 798 0600
Fax – (011) 803 7272
Email – andrea@sivest.co.za

Yours sincerely,

Kind Regards

Andrea Gibb (*B.Sc. Landscape Architecture; B.Sc.(Hons) Environmental Management*)
Environmental Practitioner and Visual Specialist
SiVEST Environmental Division



SiVEST is a Level 3 BBBEE Contributor

Direct +27 11 798 0638 Tel +27 11 798 0600 fax +27 11 803 7272 cell +27 72 587 6525
email andrea@sivest.co.za website www.sivest.co.za



Consulting Engineers - Project Managers - Environmental Consultants - Town and Regional Planners
Durban - Johannesburg - Pietermaritzburg - Richards Bay - Ladysmith - Cape Town - Harare (Zimbabwe)

Veronique Evans

From: Veronique Evans
Sent: 08 July 2015 02:38 PM
Cc: 'Danie & Jomima Bernard'; 'Jermaine Isaacs'; 'Chetna Mistry'; 'Irene Richardson'; 'Lynsey Rimbault'; 'Gerrie Rudolph'; Lynsey Rimbault; Andrea Gibb
Subject: Helena 1, 2 and 3 Landowner FGM Draft Minutes
Attachments: Helena 1-2-3 PV FGM Landowners Draft Minutes Rev 1 07Jul2015 LR - with appendices.pdf

Tracking:	Recipient	Delivery
	'Danie & Jomima Bernard'	
	'Jermaine Isaacs'	
	'Chetna Mistry'	
	'Irene Richardson'	
	'Lynsey Rimbault'	
	'Gerrie Rudolph'	
	Lynsey Rimbault	Delivered: 2015/07/08 02:38 PM
	Andrea Gibb	Delivered: 2015/07/08 02:38 PM

******* Please note that this email was sent from a NO REPLY email address. Please do not reply to this address as it is an unmonitored email account. *******

Dear Stakeholder,

Please see attached the Draft Minutes for the Landowner Focus Group Meeting held at Ietznietz Guest House, Copperton on Friday the 22nd of May 2015.

Please submit your comments on the Draft Minutes on or before Wednesday 15 July 2015.

Kind Regards

Andrea Gibb (B.Sc. Landscape Architecture; B.Sc.(Hons) Environmental Management)

Environmental Practitioner and Visual Specialist

SiVEST Environmental Division



SiVEST is a Level 3 BBBEE Contributor

Direct +27 11 798 0638 **Tel** +27 11 798 0600 **fax** +27 11 803 7272 **cell** +27 72 587 6525
email andreag@sivest.co.za **website** www.sivest.co.za



Consulting Engineers - Project Managers - Environmental Consultants - Town and Regional Planners
Durban - Johannesburg - Pietermaritzburg - Richards Bay - Ladysmith - Cape Town - Harare (Zimbabwe)

Veronique Evans

From: Veronique Evans
Sent: 08 July 2015 02:42 PM
Cc: 'Jakob Basson'; 'Jermaine Isaacs'; 'Sivemah Mdlokovama'; 'Chetna Mistry'; 'AG Nel'; 'Irene Richardson'; 'Lynsey Rimbault'; Lynsey Rimbault; 'Zak Barnard'; 'Beatrice Mondzinger'; Andrea Gibb
Subject: Helena 1, 2 and 3 Municipality FGM Draft Minutes
Attachments: Helena 1-2-3 PV FGM Municipalities Draft Minutes Rev 1_07Jul2015 LR - with appendices.pdf

Tracking:	Recipient	Delivery
	'Jakob Basson'	
	'Jermaine Isaacs'	
	'Sivemah Mdlokovama'	
	'Chetna Mistry'	
	'AG Nel'	
	'Irene Richardson'	
	'Lynsey Rimbault'	
	Lynsey Rimbault	Delivered: 2015/07/08 02:42 PM
	'Zak Barnard'	
	'Beatrice Mondzinger'	
	Andrea Gibb	Delivered: 2015/07/08 02:42 PM

******* Please note that this email was sent from a NO REPLY email address. Please do not reply to this address as it is an unmonitored email account. *******

Dear Stakeholder,

Please see attached the Draft Minutes for the Municipality Focus Group Meeting held at SiyaThemba Local Municipality's Chambers on Thursday the 21st of May 2015.

Please submit your comments on the Draft Minutes on or before Wednesday 15 July 2015.

Kind Regards

Andrea Gibb (*B.Sc. Landscape Architecture; B.Sc.(Hons) Environmental Management*)

Environmental Practitioner and Visual Specialist

SiVEST Environmental Division



SiVEST is a Level 3 BBBEE Contributor

Direct +27 11 798 0638 Tel +27 11 798 0600 fax +27 11 803 7272 cell +27 72 587 6525
email andreaq@sivest.co.za website www.sivest.co.za



Consulting Engineers - Project Managers - Environmental Consultants - Town and Regional Planners
Durban - Johannesburg - Pietermaritzburg - Richards Bay - Ladysmith - Cape Town - Harare (Zimbabwe)

Veronique Evans

From: Veronique Evans
Sent: 08 July 2015 02:51 PM
Cc: Andrea Gibb; Lynsey Rimbault; Nicolene Venter (nicolenev@zitholele.co.za)
Subject: Helena 1, 2 and 3 Public Meeting Draft Minutes
Attachments: Helena 1-2-3 PM Draft Minutes Rev 1_07Jul2015 LR - with appendices.pdf

******* Please note that this email was sent from a NO REPLY email address. Please do not reply to this address as it is an unmonitored email account. *******

Dear Stakeholder,

Please see attached the Draft Minutes for the Public Meeting held at Omega Hall, Prieska on Thursday the 21st of May 2015.

Please submit your comments on the Draft Minutes on or before Wednesday 15 July 2015.

Kind Regards

Andrea Gibb (B.Sc. Landscape Architecture; B.Sc.(Hons) Environmental Management)

Environmental Practitioner and Visual Specialist

SiVEST Environmental Division



SiVEST is a Level 3 BBBEE Contributor

Direct +27 11 798 0638 **Tel** +27 11 798 0600 **fax** +27 11 803 7272 **cell** +27 72 587 6525
email andrea@sivest.co.za **website** www.sivest.co.za



Consulting Engineers - Project Managers - Environmental Consultants - Town and Regional Planners
Durban - Johannesburg - Pietermaritzburg - Richards Bay - Ladysmith - Cape Town - Harare (Zimbabwe)

Hlengiwe Ntuli

From: Hlengiwe Ntuli
Sent: 18 August 2015 09:23 AM
Cc: Lynsey Rimbault; Andrea Gibb
Subject: Helena Solar 1, 2 & 3 Final Scoping Reports Submitted to the DEA

Tracking:	Recipient	Delivery	Read
	Lynsey Rimbault	Delivered: 2015/08/18 09:23 AM	Read: 2015/08/18 09:24 AM
	Andrea Gibb	Delivered: 2015/08/18 09:23 AM	
	'Koos Botha'		
	'Piet Papier'		
	'Sindisile Madyo'		
	'Danie & Jomima Bernard'		
	'Danielle Julies'		
	'George Karsten'		
	'Elsabe Swart'		
	'Lynsey Rimbault'		
	'John Geeringh'		
	'Ertjies Taljaart'		
	'Lizell Stoh'		
	'Almarette Nieuwoudt'		
	'Hennie Schoeman'		
	'Lorraine Nobela'		
	'Gerrie Rudolph'		
	'Zak Barnard'		
	Lynsey Rimbault		
	'Raylene Stadhouer'		
	'Albertha Kellerman'		
	'Gerhardus Rudolph'		
	'Coenie Viljoen'		
	'Ernest Kubayi'		
	'Johannes Human'		
	'Simon Gear'		
	'Hendrik Human'		
	'Carolyn Ah Shene-Verdoorn'		
	'Bradley Gibbons'		
	'Anton van Heerden'		
	'Wynand Human'		
	'Ronelle Visagie'		
	'Jakob Basson'		
	'Hester Meyer'		
	'Sonwabile Nkondeshe'		
	'Keith Woolf'		
	'Frank Andreas'		
	'Eden William'		

Recipient	Delivery	Read
'Amanda Bester'		
'Andrew Timothy'		
'AG Nel'		
'Mere Kgampe'		
'S Human'		
'Danster Muggen'		
'Justin Langfred'		
'Le-Waine Kakora'		
'Mandisa Yawa'		
'William van Staden'		
'Pilla Buis'		
'Mashudu Mukoma'		
'Benjamin Brendon Hendricks'		
'Jermaine Isaacs'		
'Thulani Mthombeni'		
'Thomas Botha'		
'Heleen van den Heever'		
'Thoko Buthelezi'		
'Sivemah Mdlokovama'		
'Simphiwe Masilela'		
'Tarryn -'		
'Jack Maccollan'		
'Miriam Kibi'		
'Sam Diokpala'		
'Paul Avenant'		
'Onwabile Ndzumo'		
'Natalie Uys'		
'Ntsundeni Ravhogoni'		
'Nico Fourie'		
'Beatrice Mondzinger'		
'JRM Alexander'		
'Ester Makungo'		
'Johan Koegelenberg'		
'Johan Badenhorst'		
'Jenna Lavin'		
'Jasper Nieuwoudt'		
'Jacoline Mans'		
'Ivan Steenkamp'		
'Suzanne Erasmus'		
'-'		
'Irene Richardson'		
'Alexia Hlengani'		
'Hettie B'		

Recipient	Delivery	Read
'Hettie Morobisi'		
'Gert Steenkamp'		
'Sam Fiff'		
'Ferlicia Ward'		
'Shaun Dyers'		
'Rene De Kock'		
'Constantine Hapzilambros'		
'Chetna Mistry'		
'Cheri Roberts'		
'Adriaan Tiplady'		
'Anneliza Collett'		
'Abe Abrahams'		

******* Please note that this email was sent from a NO REPLY email address. Please do not reply to this address as it is an unmonitored email account.*******

Dear Interested and/or Affected Party

ENVIRONMENTAL IMPACT ASSESSMENT (EIA) AND ENVIRONMENTAL MANAGEMENT PROGRAMME (EMPr) FOR THE THREE HELENA SOLAR PHOTOVOLTAIC (PV) ENERGY FACILITIES NEAR COPPERTON, NORTHERN CAPE PROVINCE

**DEA Ref. HELENA SOLAR 1: 14/12/16/3/3/2/765
HELENA SOLAR 2: 14/12/16/3/3/2/766
HELENA SOLAR 3: 14/12/16/3/3/2/767**

- FSR AVAILABLE FOR REVIEW**

We wish to express our appreciation to the stakeholders who submitted comments on the Draft Scoping Reports (DSRs) for the above mentioned proposed projects during the public review period (Thursday 28 May 2015 to Monday 29 June 2015). After the public review period, the DSRs were updated, taking into consideration the issues and concerns raised by stakeholders.

The Final Scoping Reports (FSRs) were submitted to the Department of Environmental Affairs (DEA) for their consideration on Monday 17 August 2015.

In accordance with the National Environmental Management Act (NEMA), the FSRs will be available for public comment and review from **Tuesday 18 August 2015 to Monday 7 September 2015** (end of business day). The FSRs are available on SiVEST's website: <http://www.sivest.co.za/> click on 'Downloads' (top right), then scroll down to *13031 Helena PV EIA*. Alternatively, please contact SiVEST to obtain an electronic copy of the reports on CD.

Should you have any comments on the FSRs, please submit these in writing directly to the DEA on or before **Monday 7 September 2015** (close of business day):

Department of Environmental Affairs (DEA)
Ms Mmatlala Rabothata
Private Bag X447
PRETORIA
0001
Tel: 012 399 9372

Email: mrabothata@environment.gov.za

As per the EIA Regulations, please send a copy of your comments to the SiVEST Office at the following address:

SiVEST Environmental
Andrea Gibb
PO BOX 2921
Rivonia
2128
Tel: 011 798 0600
Fax: 011 803 7272
Email: andreaG@sivest.co.za

Kind Regards,

Andrea Gibb
Environmental Practitioner
SiVEST Environmental Division



SiVEST is a Level 3 BBBEE Contributor

Direct +27 11 798 0638 **Tel** +27 11 798 0600 **fax** +27 11 803 7272
email AndreaG@sivest.co.za **website** www.sivest.co.za



Consulting Engineers - Project Managers - Environmental Consultants - Town and Regional Planners
Durban - Johannesburg - Pietermaritzburg - Richards Bay - Ladysmith - Cape Town - Harare (Zimbabwe)

Hlengiwe Ntuli

From: Hlengiwe Ntuli
Sent: 30 November 2015 02:52 PM
Cc: Andrea Gibb; Lynsey Rimbault
Subject: Helena 1, 2 and 3 Solar PV Facilities: EIA Newsletter
Attachments: 13031_Helena PV and Powerline EIA Newsletter Comment Form_Rev1_30Nov2016....pdf; 13031_Helena PV and Powerline EIA Newsletter_Rev 1_25Nov2015 LR.PDF; A3_13031_HS1_SiteLocality_LR.PDF

Tracking:	Recipient	Delivery	Read
	Andrea Gibb	Delivered: 2015/11/30 02:52 PM	Read: 2015/12/01 07:02 AM
	Lynsey Rimbault	Delivered: 2015/11/30 02:52 PM	Read: 2015/11/30 02:52 PM
	'Elsabe Swart'		
	'Keith Woolf'		
	'Lizell Stoh'		
	'Natalie Uys'		
	'Lorraine Nobela'		
	'Ntsundeni Ravhogoni'		
	'Heleen van den Heever'		
	'Amanda Bester'		
	'Rene De Kock'		
	'Shaun Dyers'		
	'Ferlicia Ward'		
	'Simpfiwe Masilela'		
	'Johanna Morobane'		
	'Jasper Nieuwoudt'		
	'Anneliza Collett'		
	'Thoko Buthelezi'		
	'Paul Avenant'		
	'Sonwabile Nkondeshe'		
	'Sindisile Madyo'		
	'Jack Maccollan'		
	'Miriam Kibi'		
	'Sam Diokpala'		
	'Johan Koegelenberg'		
	'Mere Kgampe'		
	'Thulani Mthombeni'		
	'Wynand Human'		
	'S Human'		
	'Johannes Human'		
	'Coenie Viljoen'		
	'Anton van Heerden'		
	'Eden William'		
	'Gert Steenkamp'		
	'Gerhardus Rudolph'		

Recipient	Delivery	Read
'Gerrie Rudolph'		
'Adriaan Tiplady'		
'Carolyn Ah Shene-Verdoorn'		
'Simon Gear'		
','		
'Jenna Lavin'		
'Bradley Gibbons'		
'Hendrik Human'		
'Suzanne Erasmus'		
'Nico Fourie'		
'Ivan Steenkamp'		
Lynsey Rimbault		
'Jacoline Mans'		
'Sam Fiff'		
'Andrew Timothy'		
'Piet Papier'		
'JRM Alexander'		
'Johan Badenhorst'		
'John Geeringh'		
'Raylene Stadhouer'		
'Berend van Deventer'		
'Thomas Botha'		
'Jermaine Isaacs'		
'Chetna Mistry'		
'Irene Richardson'		
'Lynsey Rimbault'		
'Onwabile Ndzumo'		
'Lourens Leeuwner'		
'William van Staden'		
'Danielle Julies'		
'Danster Muggen'		
'Benjamin Brendon Hendricks'		
'Sivemah Mdlokovama'		
'Ester Makungo'		
'Zak Barnard'		
'AG Nel'		
'Justin Langfred'		
'Le-Waine Kakora'		
'Mandisa Yawa'		
'Mashudu Mukoma'		
'Frank Andreas'		
'Abe Abrahams'		
'Almarette Nieuwoudt'		

Recipient	Delivery	Read
'Danie & Jomima Bernard'		
'Hester Meyer'		
'Beatrice Mondzinger'		
'Cheri Roberts'		
'Ernest Kubayi'		
'George Karsten'		
'Koos Botha'		
'Ertjies Taljaart'		
'Albertha Kellerman'		
'Jakob Basson'		
'Pilla Buis'		
'Tarryn -'		
'Nelson'		
'Alexia Hlengani'		
'Hettie B'		
'Hettie Morobisi'		
'Hano Hamman'		
'Constantine Hapzilambros'		

***** Please note that this email was sent from a NO REPLY email address. Please do not reply to this address as it is an unmonitored email account. *****

Dear Stakeholder

We would like to take this opportunity to inform you that the Department of Environmental Affairs has accepted the Final Scoping Reports and approved the Plan of Study for the Environmental Impact Phase of the Helena 1, 2, and 3 Solar Photovoltaic Energy Facilities.

Attached is the EIA Newsletter, Comment form and Site Locality Map for your information.

Kind Regards

Andrea Gibb (B.Sc. Landscape Architecture; B.Sc.(Hons) Environmental Management) Environmental Practitioner and Visual Specialist SiVEST Environmental Division

SiVEST is a Level 3 BBBEE Contributor

Direct +27 11 798 0638 Tel +27 11 798 0600 fax +27 11 803 7272
email andreg@sivest.co.za website www.sivest.co.za

Consulting Engineers - Project Managers - Environmental Consultants - Town and Regional Planners Durban - Johannesburg - Pietermaritzburg - Richards Bay - Ladysmith - Cape Town - Harare (Zimbabwe)

NORMAL

<input type="checkbox"/> Trace and Track Parcel (CD) <input type="checkbox"/> Registered Letter <input type="checkbox"/> Fast Mail	Project Number: 13031
Addressed To: Ms Elizabeth Hendriks 46 Wilger Street Bonteheuwel Prieska 8940	Post Office Stamp:  Tracking Number:

<input type="checkbox"/> Trace and Track Parcel (CD) <input type="checkbox"/> Registered Letter <input type="checkbox"/> Fast Mail	Project Number:
Addressed To: Mrs Mirna Van Wyk 5 Karoo Street Prieska 8940	Post Office Stamp:  Tracking Number: 2128

<input type="checkbox"/> Trace and Track Parcel (CD) <input type="checkbox"/> Registered Letter <input type="checkbox"/> Fast Mail	Project Number:
Addressed To: Mr Esmond Jansen 5 Pieterse Straat Prieska 8940	Post Office Stamp:  Tracking Number: 2128

Trace and Track Parcel (CD) Registered Letter Fast Mail	Project Number: 13031
Addressed To: Mr Nicolas Klaas Roos 4075 Smarty Town Prieska 8940	Post Office Stamp: 
	Tracking Number: 2128

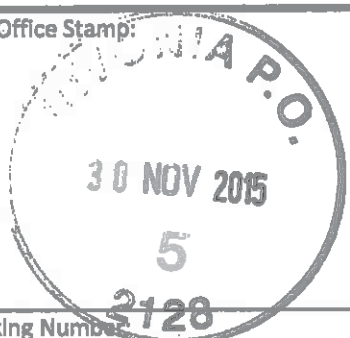
Trace and Track Parcel (CD) Registered Letter Fast Mail	Project Number:
Addressed To: Mr Wessel Bosman 4126 7 de Laan Prieska 8940	Post Office Stamp: 
	Tracking Number: 2128

Trace and Track Parcel (CD) Registered Letter Fast Mail	Project Number:
Addressed To: Ms Sanna Yanla 44 Maclean Street Prieska 8940	Post Office Stamp: 
	Tracking Number: 2128

Normac

<input type="checkbox"/> Trace and Track Parcel (CD) <input type="checkbox"/> Registered Letter <input type="checkbox"/> Fast Mail	Project Number: 13031
Addressed To: Ms Felicity Jenson 2065 Van Wyk Street Prieska 8940	Post Office Stamp: 
	Tracking Number:

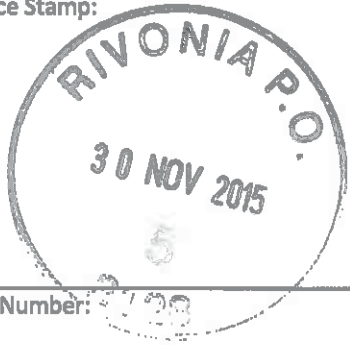
<input type="checkbox"/> Trace and Track Parcel (CD) <input type="checkbox"/> Registered Letter <input type="checkbox"/> Fast Mail	Project Number:
Addressed To: Mr Charl Julies 21 Alwyn Stret PRIESKA 8940	Post Office Stamp: 
	Tracking Number: 2128

<input type="checkbox"/> Trace and Track Parcel (CD) <input type="checkbox"/> Registered Letter <input type="checkbox"/> Fast Mail	Project Number:
Addressed To: Ms Gertruida Ludick 23 Lala Street Rooblok Prieska 8940	Post Office Stamp: 
	Tracking Number: 2128

Trace and Track Parcel (CD)	Project Number:
Registered Letter	13031
Fast Mail	
Addressed To:	Post Office Stamp:
Mr David Visser	
General Worker	
24 Street 8	Tracking Number:
Prieska	2128
8940	

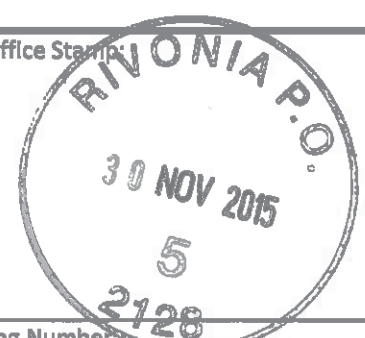
Trace and Track Parcel (CD)	Project Number:
Registered Letter	
Fast Mail	
Addressed To:	Post Office Stamp:
Ms Rozelle Hendricks	
2503 Malva Street	
Prieska	Tracking Number:
8940	2128

Trace and Track Parcel (CD)	Project Number:
Registered Letter	
Fast Mail	
Addressed To:	Post Office Stamp:
Mrs F.M. Van Wyk Ward 2	
Counsellor Siyamthemba	
Municipality	Tracking Number:
3 Upington Road	
Prieska	
8940	

Normal

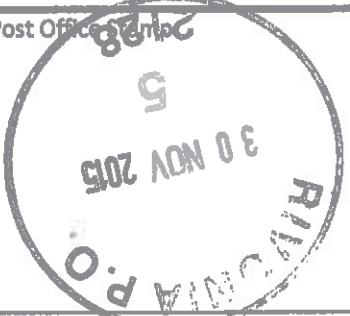
<input type="checkbox"/> Trace and Track Parcel (CD) <input type="checkbox"/> Registered Letter <input type="checkbox"/> Fast Mail	Project Number: 13031
Addressed To: Ms Gertruida Malgas 33 Karen Street Bonteheuwel Prieska 8940	Post Office Stamp: 
	Tracking Number:

<input type="checkbox"/> Trace and Track Parcel (CD) <input type="checkbox"/> Registered Letter <input type="checkbox"/> Fast Mail	Project Number:
Addressed To: Ms Nomonde Pieterse 3713 Mandela Square Prieska 8940	Post Office Stamp: 
	Tracking Number:

<input type="checkbox"/> Trace and Track Parcel (CD) <input type="checkbox"/> Registered Letter <input type="checkbox"/> Fast Mail	Project Number:
Addressed To: Mr Desmond George 3809 Mandela Square Ethembeni Prieska 8940	Post Office Stamp: 
	Tracking Number:

Trace and Track Parcel (CD) Registered Letter Fast Mail	Project Number: 13031
Addressed To: Ms Beatrice Magakwe Alwyn Street 29 Prieska 8940	Post Office Stamp: 
	Tracking Number: 2128

Trace and Track Parcel (CD) Registered Letter Fast Mail	Project Number:
Addressed To: Mr Muldry (Webb) Adonis Bloekom Straat 07 Prieska 8940	Post Office Stamp: 
	Tracking Number: 2128

Trace and Track Parcel (CD) Registered Letter Fast Mail	Project Number:
Addressed To: Ms Rene Kapater D22 Kodwa Street Ethembeni PRIESKA 8940	Post Office Stamp: 
	Tracking Number: 2128

Trace and Track Parcel (CD) Registered Letter Fast Mail	Project Number: 13031
Addressed To: Mr Sonwabo Nkone E31 Seagacho Street PRIESKA 8940	Post Office Stamp:  Tracking Number: 2128

Trace and Track Parcel (CD) Registered Letter Fast Mail	Project Number:
Addressed To: Mr Desmond Van der Westhuisen De Vriest 20 Street Prieska 8940	Post Office Stamp:  Tracking Number: 2128

Trace and Track Parcel (CD) Registered Letter Fast Mail	Project Number:
Addressed To: Mr Saul Basson General Worker Siyamthemba Municipality Damon Street 19 Prieska 8940	Post Office Stamp:  Tracking Number: 2128

Trace and Track Parcel (CD)	Project Number:
Registered Letter	13031
Fast Mail <i>NORMAL</i>	
Addressed To:	Post Office Stamp:
Mr Johannes Mohlali	
General Worker	
E33 Segaecho	Tracking Number:
Ethembeni	5
Prieska	2128
8940	

Trace and Track Parcel (CD)	Project Number:
Registered Letter	
Fast Mail	
Addressed To:	Post Office Stamp:
Mr H Nohenda	
E67 Joko Street	
Prieska	Tracking Number:
8940	5
	2128

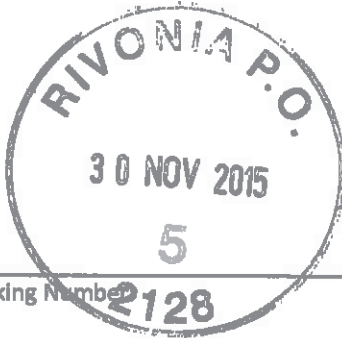
Trace and Track Parcel (CD)	Project Number:
Registered Letter	
Fast Mail	
Addressed To:	Post Office Stamp:
Mr Johannes & Kerneels	
Van Staden	
E71 Kodwa Street	Tracking Number:
Ethembeni	5
Prieska	2128
8940	

Trace and Track Parcel (CD) Registered Letter Fast Mail	Project Number: 130231
Addressed To: Mr Vivian Maritz General Worker Extension 7 4062 Prieska 8940	Post Office Stamp: 
	Tracking Number:

Trace and Track Parcel (CD) Registered Letter Fast Mail	Project Number:
Addressed To: MR MIAWUT PNIKE F66 Msebenzi Street Ethembeni Prieska 8940	Post Office Stamp: 
	Tracking Number:

Trace and Track Parcel (CD) Registered Letter Fast Mail	Project Number:
Addressed To: MR DAVID PNIKE Siyamthemba Municipality F7 Nkompelasu Prieska 8940	Post Office Stamp: 
	Tracking Number:

	Trace and Track Parcel (CD)	Project Number:
	Registered Letter	
	Fast Mail	
Addressed To:		Post Office Stamp:
<hr/>		
<hr/>		
<hr/>		
<hr/>		
<hr/>		
		Tracking Number:

	Trace and Track Parcel (CD)	Project Number:
	Registered Letter	
	Fast Mail	
Addressed To:		Post Office Stamp:
<hr/>		
<hr/>		
<hr/>		
<hr/>		
<hr/>		
		Tracking Number:

	Trace and Track Parcel (CD)	Project Number:
	Registered Letter	
	Fast Mail	
Addressed To:		Post Office Stamp:
<hr/>		
<hr/>		
<hr/>		
<hr/>		
<hr/>		
		Tracking Number:

NORMAL

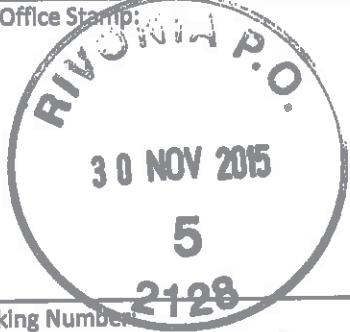
<input type="checkbox"/> Trace and Track Parcel (CD) <input type="checkbox"/> Registered Letter <input type="checkbox"/> Fast Mail	Project Number:
Addressed To: Ms Sharon Maritz Karee Street 01 Prieska 8940	Post Office Stamp: 
	Tracking Number:

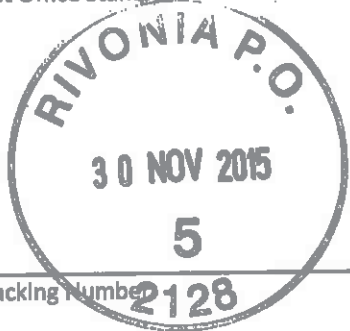
<input type="checkbox"/> Trace and Track Parcel (CD) <input type="checkbox"/> Registered Letter <input type="checkbox"/> Fast Mail	Project Number:
Addressed To: Mr Benjamin Yawa Plakkerskamp Ethembeni Prieska 8940	Post Office Stamp: 
	Tracking Number:

<input type="checkbox"/> Trace and Track Parcel (CD) <input type="checkbox"/> Registered Letter <input type="checkbox"/> Fast Mail	Project Number:
Addressed To: Ms Senobia Staden 10 Burger Street Uitbreiding 15 Prieska 8940	Post Office Stamp: 
	Tracking Number:

Trace and Track Parcel (CD) Registered Letter Fast Mail	Project Number: 13031
Addressed To: Mr Sonwabile - Snr Environmental Officer Pixliy KA Seme District Municipality Private Bag X1012 DE AAR 7000	Post Office Stamp:  Tracking Number: 2128

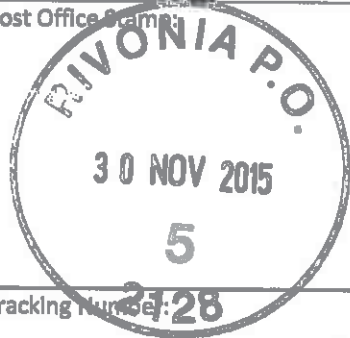
Trace and Track Parcel (CD) Registered Letter Fast Mail	Project Number:
Addressed To: Mr JJ Botha Landowner Farm: Plaaseismoer Posbus 192 PRIESKA 8940	Post Office Stamp:  Tracking Number: 2128

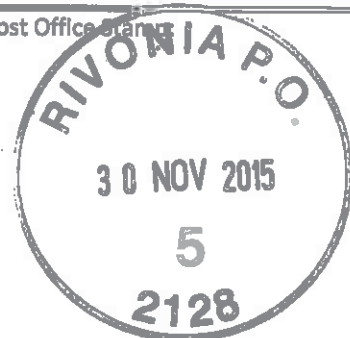
Trace and Track Parcel (CD) Registered Letter Fast Mail	Project Number:
Addressed To: Mr Ernest Botha Mathe Steet PRIESKA 8940	Post Office Stamp:  Tracking Number:

NORMAL

<input type="checkbox"/> Trace and Track Parcel (CD) <input type="checkbox"/> Registered Letter <input type="checkbox"/> Fast Mail	Project Number:
Addressed To: Mr Frans Ekkerd Landowner Farm: Uitspanpan Posbus 446 PRIESKA 8940.	Post Office Stamp:  Tracking Number:

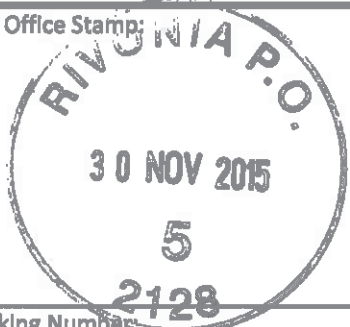
<input type="checkbox"/> Trace and Track Parcel (CD) <input type="checkbox"/> Registered Letter <input type="checkbox"/> Fast Mail	Project Number:
Addressed To: Mr Randall Smith 10 Bosman Street Rooiblok Wes-einde Prieska 8940	Post Office Stamp:  Tracking Number:

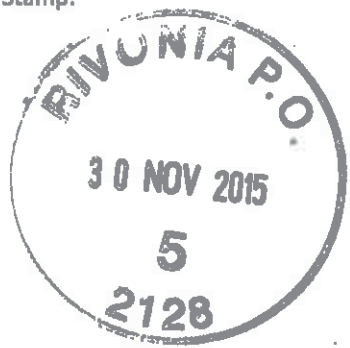
<input type="checkbox"/> Trace and Track Parcel (CD) <input type="checkbox"/> Registered Letter <input type="checkbox"/> Fast Mail	Project Number:
Addressed To: Mr Nillaas Adams General Worker Mandela Square 3652 Prieska 8940	Post Office Stamp:  Tracking Number:

<input type="checkbox"/> Trace and Track Parcel (CD) <input type="checkbox"/> Registered Letter <input type="checkbox"/> Fast Mail		Project Number:
Addressed To: _____ Ms Kholiwe Ana-Miah _____ _____ K10 Plakkers Kamp _____ _____ Prieska _____ _____ 8940 _____ _____ _____		Post Office Stamp: 
_____ _____		Tracking Number:

<input type="checkbox"/> Trace and Track Parcel (CD) <input type="checkbox"/> Registered Letter <input type="checkbox"/> Fast Mail		Project Number:
Addressed To: _____ Mr Killek Majebe _____ _____ K11 Joko Street _____ _____ Ethembeni _____ _____ Prieska _____ _____ 8940 _____ _____ _____		Post Office Stamp: 
_____ _____		Tracking Number:

<input type="checkbox"/> Trace and Track Parcel (CD) <input type="checkbox"/> Registered Letter <input type="checkbox"/> Fast Mail		Project Number:
Addressed To: _____ Mr Collin Jansen Matti _____ _____ Mattezd 23 etd _____ _____ PRIESKA _____ _____ 8940 _____ _____ _____		Post Office Stamp: 
_____ _____		Tracking Number:

NORMAL

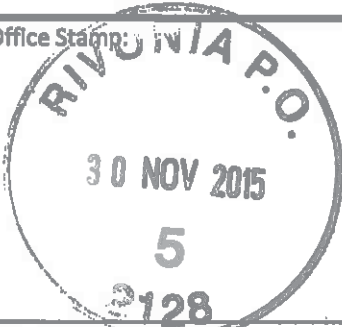
<input type="checkbox"/>	<input type="checkbox"/>	<input type="checkbox"/>	Trace and Track Parcel (CD)	Project Number:
<input type="checkbox"/>	<input type="checkbox"/>	<input type="checkbox"/>	Registered Letter	
<input type="checkbox"/>	<input type="checkbox"/>	<input type="checkbox"/>	Fast Mail	
Addressed To:				Post Office Stamp:
<hr/>				
<hr/>				
<hr/>				
<hr/>				Tracking Number:

<input type="checkbox"/>	<input type="checkbox"/>	<input type="checkbox"/>	Trace and Track Parcel (CD)	Project Number:
<input type="checkbox"/>	<input type="checkbox"/>	<input type="checkbox"/>	Registered Letter	
<input type="checkbox"/>	<input type="checkbox"/>	<input type="checkbox"/>	Fast Mail	
Addressed To:				Post Office Stamp:
<hr/>				
<hr/>				
<hr/>				
<hr/>				Tracking Number:

<input type="checkbox"/>	<input type="checkbox"/>	<input type="checkbox"/>	Trace and Track Parcel (CD)	Project Number:
<input type="checkbox"/>	<input type="checkbox"/>	<input type="checkbox"/>	Registered Letter	
<input type="checkbox"/>	<input type="checkbox"/>	<input type="checkbox"/>	Fast Mail	
Addressed To:				Post Office Stamp:
<hr/>				
<hr/>				
<hr/>				
<hr/>				Tracking Number:

<input type="checkbox"/> Trace and Track Parcel (CD) <input type="checkbox"/> Registered Letter <input type="checkbox"/> Fast Mail	Project Number:
Addressed To: Mr Rudolph Van Staden Herder Street 15 Prieska 8940.	Post Office Stamp: 
	Tracking Number: 5 2128

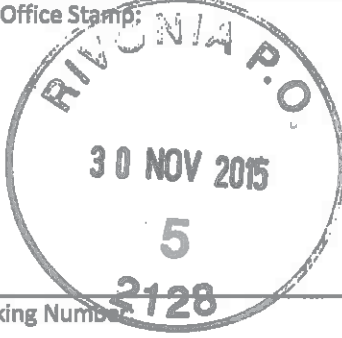
<input type="checkbox"/> Trace and Track Parcel (CD) <input type="checkbox"/> Registered Letter <input type="checkbox"/> Fast Mail	Project Number:
Addressed To: Mr Bonisehle NG General Worker F 24 MATHA STREET PRIESKA 8940	Post Office Stamp: 
	Tracking Number: 5 2128

<input type="checkbox"/> Trace and Track Parcel (CD) <input type="checkbox"/> Registered Letter <input type="checkbox"/> Fast Mail	Project Number:
Addressed To: Mr Lorenzo Berries Man Street 15 Rooiblok Prieska 8940	Post Office Stamp: 
	Tracking Number: 5 2128

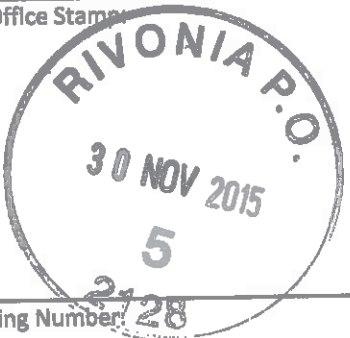
Trace and Track Parcel (CD) Registered Letter Fast Mail	Project Number: 13031
Addressed To: Mr Ronald August 15 Wilger Street Bonteheuwel Prieska 8940	Post Office Stamp: 
	Tracking Number: 2128

Trace and Track Parcel (CD) Registered Letter Fast Mail	Project Number:
Addressed To: Ms Christina Tieties 1128 Ou Upington Weg Bonteheuwel Prieska 8940	Post Office Stamp: 
	Tracking Number:

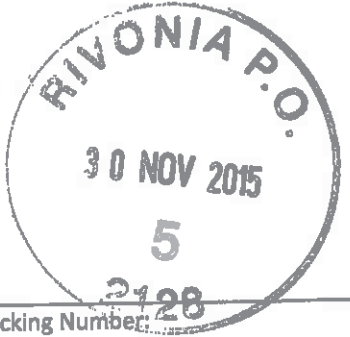
Trace and Track Parcel (CD) Registered Letter Fast Mail	Project Number:
Addressed To: Mr William Ludidi 19 Bloekom Street Bonteheuwel Prieska 8940	Post Office Stamp: 
	Tracking Number: 2128

Trace and Track Parcel (CD) Registered Letter Fast Mail	Project Number: 13031
Addressed To: Mr Presley Swarts 2065 V Wyk Street PRIESKA 8940	Post Office Stamp: 
	Tracking Number: 2128

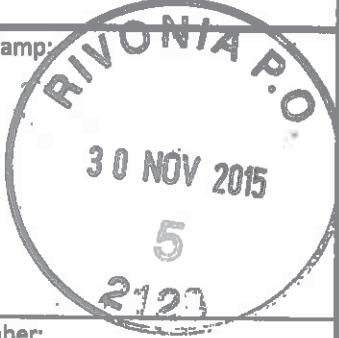
Trace and Track Parcel (CD) Registered Letter Fast Mail	Project Number:
Addressed To: Ms Petronella Puzane 16 Blesbok Street Prieska 8940	Post Office Stamp: 
	Tracking Number:

Trace and Track Parcel (CD) Registered Letter Fast Mail	Project Number:
Addressed To: Ms Rosetta Scott 13 Bosman Street Rooblok Wes-einde Prieska 8940	Post Office Stamp: 
	Tracking Number:

Hlengiwe Ntuli

From: Hlengiwe Ntuli
Sent: 09 December 2015 03:40 PM
Cc: Andrea Gibb; Lynsey Rimbault
Subject: Three Proposed Helena Solar Photovoltaic Energy Facilities: DEIAr Comment Period Starting
Attachments: 13031 Helena DEIR Notification (Afr) Rev 1 8Dec2015 AG.pdf; 13031 Helena DEIR Notification Rev 1 8Dec2015 AG.pdf; 13031 Helena Solar PV Plant DEIR Comment Form rev 1 8 Dec 2015 AG - Combined.pdf

Tracking:

Recipient	Read
Andrea Gibb	Read: 2015/12/10 07:54 AM
Lynsey Rimbault	Read: 2015/12/09 03:51 PM
'Koos Botha'	
'Piet Papier'	
'Sindisile Madyo'	
'Danie & Jomima Bernard'	
'Danielle Julies'	
'George Karsten'	
'Elsabe Swart'	
'Lynsey Rimbault'	
'Berend van Deventer'	
'John Geeringh'	
'Ertjies Taljaart'	
'Lizell Stoh'	
'Almarette Nieuwoudt'	
'Lorraine Nobela'	
'Gerrie Rudolph'	
'Zak Barnard'	
Lynsey Rimbault	
'Raylene Stadhouer'	
'Albertha Kellerman'	
'Gerhardus Rudolph'	
'Coenie Viljoen'	
'Ernest Kubayi'	
'Johannes Human'	
'Simon Gear'	
'Hendrik Human'	
'Carolyn Ah Shene-Verdoorn'	
'Bradley Gibbons'	
'Anton van Heerden'	
'Wynand Human'	
'Jakob Basson'	
'Hester Meyer'	
'Sonwabile Nkondeshe'	
'Keith Woolf'	

Recipient**Read**

'Frank Andreas'
'Eden William'
'Amanda Bester'
'Andrew Timothy'
'AG Nel'
'Mere Kgampe'
'S Human'
'Danster Muggen'
'Justin Langfred'
'Le-Waine Kakora'
'Mandisa Yawa'
'William van Staden'
'Pilla Buis'
'Mashudu Mukoma'
'Benjamin Brendon Hendricks'
'Jermaine Isaacs'
'Lourens Leeuwner'
'Thulani Mthombeni'
'Thomas Botha'
'Heleen van den Heever'
'Thoko Buthelezi'
'Sivemah Mdlakovama'
'Simpfiwe Masilela'
'Tarryn -'
'Jack Maccollan'
'Miriam Kibi'
'Sam Diokpala'
'Paul Avenant'
'Onwabile Ndzumo'
'Natalie Uys'
'Ntsundeni Ravhogoni'
'Nico Fourie'
'Nelson'
'Beatrice Mondzinger'
'JRM Alexander'
'Mashudu Marubini'
'Ester Makungo'
'Johan Koegelenberg'
'Johan Badenhorst'
'Johanna Morobane'
'Jenna Lavin'
'Jasper Nieuwoudt'
'Jacoline Mans'

Recipient**Read**

'Ivan Steenkamp'
'Suzanne Erasmus'
'.'
'Irene Richardson'
'Alexia Hlengani'
'Hettie B'
'Hettie Morobisi'
'Hano Hamman'
'Gert Steenkamp'
'Sam Fiff'
'Ferlicia Ward'
'Shaun Dyers'
'Rene De Kock'
'Constantine Hapzilambros'
'Chetna Mistry'
'Cheri Roberts'
'Adriaan Tiplady'
'Anneliza Collett'
'Abe Abrahams'

***** Please note that this email was sent from a NO REPLY email address. Please do not reply to this address as it is an unmonitored email account. *****

Dear Interested and/or Affected Party

ENVIRONMENTAL IMPACT ASSESSMENT (EIA) AND ENVIRONMENTAL MANAGEMENT PROGRAMME (EMPr) FOR THREE HELENA 75MW SOLAR PHOTOVOLTAIC (PV) ENERGY FACILITIES NEAR COPPERTON, NORTHERN CAPE PROVINCE

DEA Ref. HELENA SOLAR 1: 14/12/16/3/3/2/765
HELENA SOLAR 2: 14/12/16/3/3/2/766
HELENA SOLAR 3: 14/12/16/3/3/2/767

We would like to take this opportunity to inform you that, in accordance with the National Environmental Management Act (NEMA), the Draft Environmental Impact Assessment Reports (DEIArS) will be available for public comment and review as from Wednesday 9 December 2015 to Wednesday 27 January 2015 (end of business day). Should you wish to receive an electronic copy of the DEIArS (CD) please forward your request in writing to us. Hard copies of the DEIArS can be reviewed at any of the following public places:

VENUE : Elizabeth Vermeulen Public Library

STREET ADDRESS: Corner Victoria Street and Steward Street, Prieska

HOURS : Mondays- Fridays 08h45 – 16h15
Saturday 08h00 – 13h00

CONTACT NO : 053 353 5300/ 053 353 5305

The reports are also available on SiVEST's website: <http://www.sivest.co.za/>, then browse to the folder '13031 Helena PV EIA'.

Beste Belangstellende en/of Geaffekteerde Party

OMGEWINGSIMPAKEVALUERING (OIE) EN OMGEWINGSBESTUURSPROGRAM (OBPr) VIR DIE DRIE HELENA FOTVOLTAÏESE ENERGIE FASILITEITE NABY COPPERTON, NOORD-KAAPROVINSIE

DO OIE Verw. No.: HELENA SOLAR 1: 14/12/16/3/3/2/765
HELENA SOLAR 2: 14/12/16/3/3/2/766
HELENA SOLAR 3: 14/12/16/3/3/2/767

Graag maak ons van hierdie geleentheid gebruik om u in te lig dat, ingevolge die Nasionale Wet op Omgewingsbestuur (NEMA), die Konsep Omgewingevalueeringsverslae beskikbaar sal wees vir openbare kommentaar en oorsig vanaf Woensdag 9 Desember 2015 tot Woensdag 27 Januarie 2016 (teen sluitingstyd). Sou u graag 'n elektroniese kopie van die Konsep Omgewingevalueeringsverslae op CD wil ontvang, kan u dit skriftelik by ons aanvra. Gedrukte eksemplare van die Konsep Omgewingevalueeringsverslae sal ook by die volgende openbare plek beskikbaar wees vir besigtiging:

PLEK : Elizabeth Vermeulen Openbare Biblioteek

STRAATADRES : Hoek van Victoriastraat en Stewardstraat, Prieska

KANTOOR URE : Maandae- Vrydae 08h45 – 16h15
Saterdag 08h00 – 13h00

KONTAKNO. : 053 353 5300/ 053 353 5305

Die Verslae is ook op SiVEST se webtuiste beskikbaar: <http://www.sivest.co.za/>, klik dan op die legger '13031 Helena PV EIA'.

Kind Regards

Andrea Gibb (B.Sc. Landscape Architecture; B.Sc.(Hons) Environmental Management) Environmental Practitioner and Visual Specialist SiVEST Environmental Division

SiVEST is a Level 3 BBBEE Contributor

Direct +27 11 798 0638 Tel +27 11 798 0600 fax +27 11 803 7272
email andreag@sivest.co.za website www.sivest.co.za

Consulting Engineers - Project Managers - Environmental Consultants - Town and Regional Planners Durban - Johannesburg - Pietermaritzburg - Richards Bay - Ladysmith - Cape Town - Harare (Zimbabwe)

Your reference:

Our reference: 13031

Date: 9 December 2015

Dear Interested and/or Affected Party

**ENVIRONMENTAL IMPACT ASSESSMENT (EIA) AND ENVIRONMENTAL MANAGEMENT PROGRAMME (EMPr)
FOR THE THREE HELENA SOLAR PHOTOVOLTAIC (PV) ENERGY FACILITIES NEAR COPPERTON,
NORTHERN CAPE PROVINCE**

DEA Ref. HELENA SOLAR 1: 14/12/16/3/3/2/765
HELENA SOLAR 2: 14/12/16/3/3/2/766
HELENA SOLAR 3: 14/12/16/3/3/2/767

• AVAILABILITY OF DRAFT ENVIRONMENTAL IMPACT ASSESSMENT REPORTS FOR PUBLIC REVIEW

We would like to take this opportunity to inform you that, in accordance with the National Environmental Management Act (NEMA), the Draft Environmental Impact Assessment Reports (DEIARs) will be available for public comment and review as from **Wednesday 9 December 2015 to Wednesday 27 January 2016** (end of business day). Should you wish to receive an electronic copy of the DEIARs (CD) please forward your request in writing to us. Hard copies of the DEIARs can be reviewed at the following public place:

VENUE	STREET ADDRESS	HOURS	CONTACT NO
Elizabeth Vermeulen Public Library	Corner of Victoria Street and Steward Street, Prieska	Mondays- Fridays 08h45 – 16h15 Saturday 08h00 – 13h00	053 353 5300/ 053 353 5305

The reports are also available on SiVEST's website: <http://www.sivest.co.za/>, then browse to the folder '13031 Helena PV EIA':

We would like to thank you in anticipation of your active and meaningful contribution to the EIA and Public Participation process.

Kind Regards



Andrea Gibb
Environmental Consultant
SiVEST Environmental Division

Documents attached: DEIAR Comment Form

U verwysing:

Ons verwysing: 13031

Datum: 9 Desember 2015

Beste Belangstellende en/of Geaffekteerde Party

OMGEWINGSIMPAKEVALUERING (OIE) EN OMGEWINGSBESTUURSPROGRAM (OBPr) VIR DIE DRIE HELENA FOTOVOLTAIESE ENERGIE FASILITEITE NABY COPPERTON, NOORD-KAAPROVINSIE

DO OIE Verw. No.: HELENA SOLAR 1: 14/12/16/3/3/2/765
HELENA SOLAR 2: 14/12/16/3/3/2/766
HELENA SOLAR 3: 14/12/16/3/3/2/767

• **UITNODIGING OM KOMENTAAR TE LEWER OP DIE KONSEP OMGEWINGEVALUERINGSVERSLAE**

Graag maak ons van hierdie geleentheid gebruik om u in te lig dat, ingevolge die Nasionale Wet op Omgewingsbestuur (NEMA), die Konsep Omgewingevalueringverslae beskikbaar sal wees vir openbare kommentaar en oorsig vanaf **Woensdag 9 Desember 2015 tot Woensdag 27 Januarie 2016** (teen sluitingstyd). Sou u graag 'n elektroniese kopie van die Konsep Omgewingevalueringverslae op CD wil ontvang, kan u dit skriftelik by ons aanvra. Gedrukte eksemplare van die Konsep Omgewingevalueringverslae sal ook by die volgende openbare plek beskikbaar wees vir besigtiging:

PLEK	STRAATADRES	KANTOOR URE	KONTAKNO.
Elizabeth Vermeulen Openbare Biblioteek	Hoek van Victoriastraat en Stewardstraat, Prieska	Maandae- Vrydae 08h45 – 16h15 Saterdag 08h00 – 13h00	053 353 5300/ 053 353 5305

Die Verslae is ook op SiVEST se webtuiste beskikbaar: <http://www.sivest.co.za/>, klik dan op die legger '13031 Helena PV EIA'.

Ons moedig u bywoning en deelname by die Publiekevergadering aan en dank u byvoorbaat vir u aktiewe en betekenisvolle bydrae tot die OIS-proses.

Vriendelike groete





Andrea Gibb
Omgewingskonsultant
SiVEST Omgewingsafdeling

Ingeslote Dokumente: Komentaarvorm

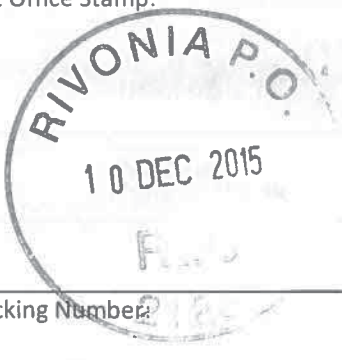
<input type="checkbox"/>	Trace and Track Parcel (CD)	Project Number:
<input type="checkbox"/>	Registered Letter	13031
<input checked="" type="checkbox"/>	Fast Mail	
Addressed To:		Post Office Stamp:
Mr Quarney Klein 10 Karroo Street Bonteheuwel Prieska 8940		
		Tracking Number:

<input type="checkbox"/>	Trace and Track Parcel (CD)	Project Number:
<input type="checkbox"/>	Registered Letter	13031
<input checked="" type="checkbox"/>	Fast Mail	
Addressed To:		Post Office Stamp:
Ms Rene Kapater D22 Kodwa Street Ethembeni PRIESKA 8940		
		Tracking Number:

<input type="checkbox"/>	Trace and Track Parcel (CD)	Project Number:
<input type="checkbox"/>	Registered Letter	13031
<input checked="" type="checkbox"/>	Fast Mail	
Addressed To:		Post Office Stamp:
Mr Nillaas Adams General Worker Mandela Square 3652 Prieska 8940		
		Tracking Number:

<input type="checkbox"/>	Trace and Track Parcel (CD)	Project Number:
<input type="checkbox"/>	Registered Letter	13031
<input checked="" type="checkbox"/>	Fast Mail	
Addressed To:		Post Office Stamp:
<hr/> <hr/> <hr/> <hr/> <hr/>		
<hr/> <hr/> <hr/> <hr/> <hr/>		
<hr/> <hr/> <hr/> <hr/> <hr/>		

<input type="checkbox"/>	Trace and Track Parcel (CD)	Project Number:
<input type="checkbox"/>	Registered Letter	13031
<input checked="" type="checkbox"/>	Fast Mail	
Addressed To:		Post Office Stamp:
<hr/> <hr/> <hr/> <hr/> <hr/>		
<hr/> <hr/> <hr/> <hr/> <hr/>		
<hr/> <hr/> <hr/> <hr/> <hr/>		

<input type="checkbox"/>	Trace and Track Parcel (CD)	Project Number:
<input type="checkbox"/>	Registered Letter	13031
<input checked="" type="checkbox"/>	Fast Mail	
Addressed To:		Post Office Stamp:
<hr/> <hr/> <hr/> <hr/> <hr/>		
<hr/> <hr/> <hr/> <hr/> <hr/>		
<hr/> <hr/> <hr/> <hr/> <hr/>		

Hlengiwe Ntuli

From: Hlengiwe Ntuli
Sent: 14 December 2015 11:04 AM
To: Andrea Gibb; Lynsey Rimbault
Cc: 'Sindisile Madyo'; 'John Geeringh'; 'Lizell Stoh'; 'Simon Gear'; 'Amanda Bester'; 'Andrew Timothy'; 'Lourens Leeuwner'; 'Thulani Mthombeni'; 'Heleen van den Heever'; 'Thoko Buthelezi'; 'Simphiwe Masilela'; 'Onwabile Ndzumo'; 'JRM Alexander'; 'Mashudu Marubini'; 'Ester Makungo'; 'Johan Koegelenberg'; 'Johanna Morobane'; 'Jenna Lavin'; 'Jasper Nieuwoudt'; 'Jacoline Mans'; 'Ivan Steenkamp'; 'Suzanne Erasmus'; 'Gert Steenkamp'; 'Sam Fiff'; 'Shaun Dyers'; 'Adriaan Tiplady'
Subject: Three Proposed Helena Solar Photovoltaic Energy Facilities: DEIAr Available for Comment

***** Please note that this email was sent from a NO REPLY email address. Please do not reply to this address as it is an unmonitored email account. *****

Dear Stakeholder

ENVIRONMENTAL IMPACT ASSESSMENT (EIA) FOR THE PROPOSED CONSTRUCTION OF THREE HELENA 75MW SOLAR PHOTOVOLTAIC (PV) ENERGY FACILITIES NEAR COPPERTON, NORTHERN CAPE PROVINCE

- DEA Ref No: HELENA SOLAR 1: 14/12/16/3/3/2/765
HELENA SOLAR 2: 14/12/16/3/3/2/766
HELENA SOLAR 3: 14/12/16/3/3/2/767

As indicated in the email which was sent you on Wednesday 9 December 2015, we would like to remind you that in accordance with the National Environmental Management Act (NEMA), the three Draft Environmental Impact Assessment Reports (DEIArs) have been made available for public comment and review as from Wednesday 9 December 2015 to Wednesday 27 January 2016 (end of business day).

For your convenience, electronic copies (on CD) of the three DEIArs as well as the accompanying appendices have been posted to you. The reports are also available on SiVEST's website: <http://www.sivest.co.za/>, click on 'Downloads' and then browse to the folder '13031 Helena PV EIA'. We kindly request that you submit your comments to us at the below details, on or before Wednesday 27 January 2016 (end of business day). In terms of section 56 (7) of the Environmental Impact Assessment Regulations 2010, under Government Notices No R543, comments from state departments will be accepted until Monday 8 February 2016 (end of business day). SiVEST will forward any comments received after the public comment and review period directly to the relevant case officer at the Department of Environmental Affairs (DEA).

Should you have any questions or queries please do not hesitate to contact us at:

Andrea Gibb / Lynsey Rimbault
PO BOX 2921, Rivonia, 2128
Tel – (011) 798 0600
Fax – (011) 803 7272
Email – andreag@sivest.co.za / lynseyr@sivest.co.za

Kind Regards

Andrea Gibb (B.Sc. Landscape Architecture; B.Sc.(Hons) Environmental Management) Environmental Practitioner and Visual Specialist SiVEST Environmental Division

SiVEST is a Level 3 BBBEE Contributor

Direct +27 11 798 0638 Tel +27 11 798 0600 fax +27 11 803 7272
email andreag@sivest.co.za website www.sivest.co.za

Consulting Engineers - Project Managers - Environmental Consultants - Town and Regional Planners Durban -
Johannesburg - Pietermaritzburg - Richards Bay - Ladysmith - Cape Town - Harare (Zimbabwe)

Your reference:

Our reference: 13031

Date: 22 January 2016

Dear Interested and/or Affected Party,

**ENVIRONMENTAL IMPACT ASSESSMENT (EIA) AND ENVIRONMENTAL MANAGEMENT PROGRAMME (EMPr)
FOR THE THREE HELENA SOLAR PHOTOVOLTAIC (PV) ENERGY FACILITIES NEAR COPPERTON,
NORTHERN CAPE PROVINCE**

**DEA Ref. HELENA SOLAR 1: 14/12/16/3/3/2/765
HELENA SOLAR 2: 14/12/16/3/3/2/766
HELENA SOLAR 3: 14/12/16/3/3/2/767**

• NOTIFICATION OF THE END OF THE DRAFT ENVIRONMENTAL IMPACT ASSESSMENT REPORTS PUBLIC REVIEW PERIOD

We would like to take this opportunity to remind you that, in accordance with the National Environmental Management Act (NEMA), the Draft Environmental Impact Assessment Reports (DEIars) are available for public comment and review as from **Wednesday 9 December 2015 to Wednesday 27 January 2016** (end of business day).

Hard copies of the DEIars can be reviewed at the following public place:

VENUE	STREET ADDRESS	HOURS	CONTACT NO
Elizabeth Vermeulen Public Library	Corner of Victoria Street and Steward Street, Prieska	Mondays- Fridays: 08h45 – 16h15 Saturday: 08h00 – 13h00	053 353 5300/ 053 353 5305

The reports are also available on SiVEST's website: <http://www.sivest.co.za/>, then browse to the folder '13031 Helena PV EIA'. Should you wish to submit comments please submit these before the end of business on Wednesday 27 January 2016.

Public meetings will not be held in January 2016 as was planned, but you will be notified accordingly once these have been scheduled.

We would like to thank you in anticipation of your active and meaningful contribution to the EIA and Public Participation process.

Kind Regards,



Andrea Gibb
Environmental Consultant
SiVEST Environmental Division

Documents attached: DEIAr Comment Form

U verwysing:

Ons verwysing: 13031

Datum: 22 Januarie 2016

Beste Belangstellende en/of Geaffekteerde Party,

OMGEWINGSIMPAKEVALUERING (OIE) EN OMGEWINGSBESTUURSPROGRAM (OBPr) VIR DIE DRIE HELENA FOTOVOLTAÏESE ENERGIE FASILITEITE NABY COPPERTON, NOORD-KAAPROVINSIE

DO OIE Verw. No.: HELENA SOLAR 1: 14/12/16/3/3/2/765
HELENA SOLAR 2: 14/12/16/3/3/2/766
HELENA SOLAR 3: 14/12/16/3/3/2/767

- **KENNISGEWING VAN DIE EINDE VAN DIE KONSEP OMGEWINGEVALUERINGSVERSLAE SE OPENBARE OORSIGTYDPERK**

Graag maak ons van hierdie geleentheid gebruik om u te herinner dat, ingevolge die Nasionale Wet op Omgewingsbestuur (NEMA), die Konsep Omgewingevalueringverslae beskikbaar is vir openbare kommentaar en oorsig vanaf **Woensdag 9 Desember 2015** tot **Woensdag 27 Januarie 2016** (teen sluitingstyd).

Gedrukte eksemplare van die Konsep Omgewingevalueringverslae sal ook by die volgende openbare plek beskikbaar wees vir besigtiging:

PLEK	STRAATADRES	KANTOOR URE	KONTAKNO.
Elizabeth Vermeulen Openbare Biblioteek	Hoek van Victoriastraat en Stewardstraat, Prieska	Maandae- Vrydae: 08h45 – 16h15 Saterdag: 08h00 – 13h00	053 353 5300/ 053 353 5305

Die verslae is ook op SiVEST se webtuiste beskikbaar: <http://www.sivest.co.za/>, klik dan op die legger '13031 Helena PV EIA'. Indien u kommentaar wil lewer dien asseblief hierdie in voor sluitingstyd op Woensdag 27 Januarie 2016.

Openbare vergaderings sal nie in Januarie 2016 gehou word nie as beplan, maar u sal dienooreenkomstig in kennis gestel word sodra hierdie geskeduleer is.

Ons moedig u bywoning en deelname by die Publiekevergadering aan en dank u byvoorbaat vir u aktiewe en betekenisvolle bydrae tot die OIS-proses.

Vriendelike groete,





Andrea Gibb
Omgewingskonsultant
SiVEST Omgewingsafdeling

Ingeslote Dokumente: Komentaarvorm

Trace and Track Parcel (CD) Registered Letter		Project Number: 13031
Addressed To: LAST MAIL		Post Office Stamp: 
Mr Quarney Klein 10 Karroo Street Bonteheuwel Prieska 8940		Tracking Number:

Trace and Track Parcel (CD) Registered Letter LAST MAIL		Project Number: 13031
Addressed To:		Post Office Stamp: 
Mr Bonisehle NG General Worker F24 Matha Street Prieska 8940		Tracking Number:

Trace and Track Parcel (CD) Registered Letter		Project Number: 13031
Addressed To:		Post Office Stamp: 
Mr David Visser General Worker 24 Street 8 Prieska 8940		Tracking Number:

Trace and Track Parcel (CD) Registered Letter		Project Number: 13031
Addressed To: <i>LAST MAIL</i>		Post Office Stamp: 
Mr H Nohenda E67 Joko Street Prieska 8940		Tracking Number:

Trace and Track Parcel (CD) Registered Letter		Project Number:
Addressed To:		Post Office Stamp: 
Mr Nillaas Adams General Worker Mandela Square 3652 Prieska 8940		Tracking Number: 2128

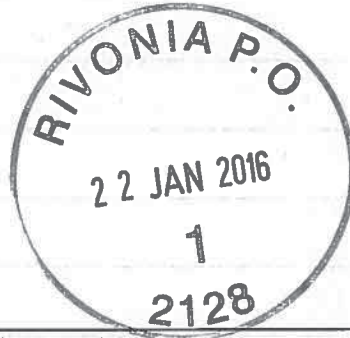
Trace and Track Parcel (CD) Registered Letter <i>LAST MAIL</i>		Project Number: 13031
Addressed To:		Post Office Stamp: 
Ms Rene Kapater D22 Kodwa Street Ethembeni PRIESKA 8940		Tracking Number:



Appendix 5C: Proof of Advertisements



Implanting kan hom weer laat hoor

GEMSBOK-UPINGTON: 'n kogleëre implanting kan klein Shanwill Mouton se lewe drasties verander.

Hierdie opgeruimde en lewenslustige seuntjie is met uitermatige bilaterale sensories-neurale gehoor verlies gedagnoseer. Dit beteken dat hy, heel moontlik sedert sy geboorte, feitlik niks kan hoor nie. Shanwill, wat vanjaar sesjaar oud word, is onlangs deur die Foundation for Children with Hearing Loss in South Africa, as 'n goeie kandidaat vir 'n kogleëre implanting bestempel.

Die operasie kan help dat Shanwill se spraak en taal nog kan ontwikkel, sodat hy met sy geteëldes en maatjies kan kommunikeer. As die operasie nie nou gedoen word nie, mag die gehoorgedeelte van sy brein so drasties verander, dat die implanting nie moontlik sal wees nie.

Een kogleëre apparaat kos sowat R275 000, waarvan die mediese fonds stegs R187 000 betaal. Dit beteken Shanwill se familie moet baie dringend R88 000 opdoek, sodat die operasie so gou moontlik gedoen kan word. Daar is 'n fonds gestig, waarin gelde wat vir Shanwill ingesameld word inbetaal kan word.

Enige persone wat 'n bydrae wil maak, hoe klein dit ookal is kan dit inbetaal by die volgende rekening: Rekening naam: Foundation for Children with a Hearing Loss in SA

Bank: Standard Bank Tak: Gezina

Tak kode: 01484500

Rekening nommer: 011794798

Verwysing: AB/Moutons

Betalingsbewyse moet gestuur word

aan Rinie Lotter by fax nommer: 086

643 6595

Kansa Relay for Life 2015

UPINGTON: Upington Kansa se jaarlikse Relay for Life word op Saterdag, 28 Maart 2015 by Die Eiland se veld gehou.

Die publiek word aangemoedig om spanne of besighede in te skryf vir hierdie groot fees gebeurtenis in die gegew teen kanker.

Hierdie deurmaagstap belooft om 'n prettige geleentheid vir die hele gesin te wees, sowel as 'n spanbou ervaring vir jou besigheid.

Skrif vandag jou span in en maak 'n verskil. 'n Reeks van vermaak word dwars deur die nag verskaf en hope pret vir almal. Vir meer inligting rondom die inskrywings skakel die Upington Kansa kantoor by 054 332 4937.

Vervolg van bl. 5

Radio Riverside gee beurse ter waarde van R143 920

Verlede jaar het 32 studente beurse ontvang van Radio Riverside en meeste van hierdie studente het goed gevaar en is in 2015 besig met hulle tweede jaar van studies.

Me Samatha Titus die voorsitter van die raad van Radio Riverside sê dat die vele aansoek wat Radio Riverside ontvang het vir hierdie beurse is 'n aanduiding dat baie jongmense in ons gemeenskappe gretig is om hul studies voort te sit, maar dat die finansiële hulpbronne die meeste van die tyd 'n hindernis is. Titus het die studente aangemoedig om hierdie geleentheid met albei hande aan te gryp en die onderrig te gebruik as 'n instrument om hul lewens te verbeter in die gemeenskappe waarin hulle woon.

Belinda Boer een van die studente wie 'n beurs ontvang het, het Radio Riverside bedank vir die geleentheid en gesê, dat hulle almal bereid is om die beste van die geleentheid te maak, aangesien onderwys 'n belangrike instrument is om te hê as jy jou drome wil bereik.

SIVEST
Omgevingsafdeling

SIVEST
Establis in 1982

OMGEWINGSIMPAAKVALUERING (OIE) EN OMGEWINGSBESTUURSPROGRAM (OBPP) VIR DIE VOORGESTELDE ONTWIKKELING VAN DRIE 75 MW FOTVOLTAÏESE (FV) SONKRAGAANLEGTE NABY COPPERTON, NOORD-KAAPROVINSIE

HELENA SOLAR 1 – DO Verw. No.: 14/12/16/3/2/765
HELENA SOLAR 2 – DO Verw. No.: 14/12/16/3/3/2/766
HELENA SOLAR 3 – DO Verw. No.: 14/12/16/3/3/2/767

Ingevolge die Nasionale Wet op Omgevingsbestuur, 1998 (Wet 107 van 1998) (NEMA), soos gewysig, en die Regulasies en Omgevingsimpakbeoordelings (OIE-regulasies) ingevolge Staatskennisgewing R543, R544, R545 en R546 wat op 18 Junie 2010 ingevolge Artikel 24(5) afgekondig is, aangesels met Artikel 44 van NEMA, geskied kennis hiermee dat BioTherm Energy (Edms.) Bpk. SIVEST SA (Edms.) Bpk. aangesel het as die onafhanklike omgewingsbeoordelingspraktisyn (OBPP) ten einde die nodige OIE en OBPP-beoordelingsprosesse vir die bogenoemde voorgestelde projekte ten opsigte van die volgende gelyste aktiwiteite te onderneem:

Staatskennisgewing R544 (18 Junie 2010)	Lysing 1 Aktiviteit (10)	(11)	(18)	(22)	(26)	(38)	(39)	(47)
Staatskennisgewing R545 (18 Junie 2010)								
Staatskennisgewing R546 (18 Junie 2010)	Lysing 2 Aktiviteit (1)	(15)						
	Lysing 3 Aktiviteit (4)	(12)	(13)	(14)	(16)	(19)		

Hoewel nuwe OIE-regulasies op 4 Desember 2014 afgekondig en op 8 Desember 2014 in werking gestel is (Staatskoerantnommer 38282), is die aansoek vir die drie voorgestelde FV-sonkragaanlegte by die Departement van Omgewingsake (DO) ingedien voordat die 2014 OIE-regulasies in werking getree het. Kragtens Regulasie 53(1) van die 2014 OIE-regulasies, moet enige aansoek wat ingevolge die vorige NEMA-regulasies ingedien is, onderneem word asof die vorige NEMA-regulasies nie herroep is nie. Die OIE-proses sal derhalwe ingevolge die 2010 OIE-regulasies onderneem word.

PROJEKBERYKING

BioTherm Energy (Edms.) Bpk. stel die oprigting van 'n drie fase fotovoltaïese (FV) sonkragaanleg met 'n totale uitvoervermoë van 225 MW. Die voorgestelde projek sal bestaan uit drie FV-sonkragaanlegte met 'n totale uitvoervermoë van sowat 75 MW elk, wat as Helena Solar 1, 2 en 3 sal bekendstaan. Elke FV-sonkragaanleg sal uit sowat 300 000 FV-paneel en gepaardgaande infrastruktuur bestaan. Die voorgestelde FV-sonkragaanlegte sal via 'n kraglyn van minder as 275 kV by die Kronos Substasie by die nasionale distribusienetwerk aansluit.

PROJEKLEIGING

Die voorgestelde projek is in die Noord-Kaaprovinsie, sowat 9 km suid van Copperton geleë. Dit is in die Siyethemba Plaaslike Munisipaliteit geleë wat deel vorm van die Pixley ka Seme Distrikmunisipaliteit. Die projek sal die volgende plekke in:

- Gedeelte 3 van die plaas Kippagatspan No. 117 (sonkragaanlegte)
- Gedeelte 4 van die plaas Kippagatspan No. 117 (kraglyn)

U word hiermee in kennis gestel dat SIVEST die tersaaklike Aansoekvorms by die DO ingedien het en dat die voorgestelde projekte onder die verwysingsnommers wat hierbo aangedui is, by die DO geregistreer is.

Ten einde as 'n Belangstellende en/of Geïnteresseerde Party (B&GP) te registreer en/of om meer inligting te bekom, moet u asseblief u naam, kontakbesonderhede en die belang wat u by die aansoek het binne 30 dae vanaf die datum van hierdie kennisgewing indien.

Rig asseblief u skriftelike navrae aan die Omgevingskonsultante hieronder:

Andrea Gibb of Lynsey Rimbault
SIVEST Environmental
Posbus 2921
RIVONIA
2128
lynseyr@sivest.co.za
Webwerf: www.sivest.co.za

Andrea Gibb or Lynsey Rimbault
SIVEST Environmental
P.O. Box 2921
RIVONIA
2128
lynseyr@sivest.co.za
Website: www.sivest.co.za

SIVEST
Environmental Division

SIVEST
Establis in 1982

ENVIRONMENTAL IMPACT ASSESSMENT (EIA) AND ENVIRONMENTAL MANAGEMENT PROGRAMME (EMPP) FOR THE PROPOSED DEVELOPMENT OF THREE 75MW SOLAR PHOTOVOLTAIC (PV) ENERGY FACILITIES NEAR COPPERTON, NORTHERN CAPE PROVINCE

HELENA SOLAR 1 – DEA Ref No: 14/12/16/3/2/765

HELENA SOLAR 2 – DEA Ref No: 14/12/16/3/3/2/766

HELENA SOLAR 3 – DEA Ref No: 14/12/16/3/3/2/767

In terms of the National Environmental Management Act, 1998 (Act No. 107 of 1998) (NEMA) as amended and the Environmental Impact Assessment (EIA) Regulations, under Government Notice No. R543, R544, R545 and R546 promulgated on 18 June 2010, Section 24 (5) read with section 44 of the NEMA, notice is hereby given that BioTherm Energy (Pty) Ltd has appointed SIVEST SA (Pty) Ltd, as the independent environmental assessment practitioner (EAP), to undertake the required EIA and public participation for the above-mentioned proposed projects in terms of the following listed activities:

Government Notice R544 (18 June 2010)	Lysing 1 Aktiviteit (10)	(11)	(18)	(22)	(26)	(38)	(39)	(47)
Government Notice R545 (18 June 2010)								
Government Notice R546 (18 June 2010)	Lysing 2 Aktiviteit (1)	(15)						
	Lysing 3 Aktiviteit (4)	(12)	(13)	(14)	(16)	(19)		

Although new EIA Regulations were promulgated on 4 December 2014 and came into effect on 8 December 2014 (Government Gazette No. 38282), the application forms for the three proposed solar PV energy facilities were submitted to the Department of Environmental Affairs (DEA), prior to the 2014 EIA Regulations taking effect. In accordance with Regulation 53 (1) of the 2014 EIA Regulations, any applications submitted in terms of the previous NEMA regulations must be undertaken as if the previous NEMA regulations were not repealed. The EIA process will therefore be undertaken in accordance with the 2010 EIA Regulations.

PROJECT DESCRIPTION

BioTherm Energy (Pty) Ltd are proposing to construct a three phase solar photovoltaic (PV) energy facility with a total export capacity of 225MW. The proposed project will consist of three solar PV facilities with a total capacity of approximately 75MW each, referred to as Helena Solar 1, 2 and 3. Each solar PV energy facility will consist of approximately 300 000 solar PV panels and associated infrastructure. The proposed solar PV facilities will connect with the national distribution network at Kronos substation via a power line of less than 275kV.

PROJECT LOCATION

The proposed project is located within the Northern Cape Province, approximately 9km south of Copperton. It falls within the Siyethemba Local Municipality that forms part of the Pixley ka Seme District Municipality. The project includes the following farms:

- Portion 3 of the farm Kippagatspan No. 117 (solar facilities)
- Portion 4 of the farm Kippagatspan No. 117 (power line)

You are hereby informed that SIVEST has submitted the relevant Application Forms to the DEA and that the proposed projects are registered with them under the reference numbers listed above.

To register as an Interested and / or Affected Party (I&AP) and / or to obtain additional information please submit your name, contact details and the interest which you have in the application within 30 days from the date of this notice.

Please direct enquiries, in writing, to the Environmental Consultants below:

OMGEWINGSIMPAKEVALUERING (OIE) EN OMGEWINGSBESTUURSPROGRAM (OBPr) VIR DIE VOORGESTELDE ONTWIKKELING VAN DRIE 75 MW FOTVOLTAÏESE (FV) SONKRAGANLEGTE NABY COPPERTON, NOORD-KAAPROVINSIE

HELENA SOLAR 1 – DO Verw. No.: 14/12/16/3/3/2/765
HELENA SOLAR 2 – DO Verw. No.: 14/12/16/3/3/2/766
HELENA SOLAR 3 – DO Verw. No.: 14/12/16/3/3/2/767

Ingevolge die Nasionale Wet op Omgewingsbestuur, 1998 (Wet 107 van 1998) (NEMA), soos gewysig, en die Regulasies op Omgewingsimpakevaluerings (OIE-regulasies) ingevolge Staatskenningsgewing R543, R544, R545 en R546 wat op 18 Junie 2010 ingevolge Artikel 24(5) afgekondig is, saamgelees met Artikel 44 van NEMA geskied kennis hiermee dat BioTherm Energy (Edms.) Bpk. SiVEST SA (Edms.) Bpk. aangestel het as die onafhanklike omgewingsevalueringspraktisyn (OEP) ten einde die nodige OIE en openbare deelnameproses vir die bogenoemde voorgestelde projekte ten opsigte van die volgende gelyste aktiwiteite te onderneem:

Staatkenningsgewing R544 (18 Junie 2010)								
Lysting 1 Aktiwiteit	(10)	(11)	(18)	(22)	(26)	(38)	(39)	(47)
Staatkenningsgewing R545 (18 Junie 2010)								
Lysting 2 Aktiwiteit	(1)	(15)						
Staatkenningsgewing R546 (18 Junie 2010)								
Lysting 3 Aktiwiteit	(4)	(12)	(13)	(14)	(16)	(19)		

Hoewel nuwe OIE-regulasies op 4 Desember 2014 afgekondig en op 8 Desember 2014 in werking gestel is (Staatskoerantnommer 38282), is die aansoekvorms vir die drie voorgestelde FV-sonkragaanlegte by die Departement van Omgewingsake (DO) ingedien voordat die 2014 OIE-regulasies in werking getree het. Kragtens Regulasie 53(1) van die 2014 OIE-regulasies, moet enige aansoeke wat ingevolge die vorige NEMA-regulasies ingedien is, onderneem word asof die vorige NEMA-regulasies nie herroep is nie. Die OIE-proses sal derhalwe ingevolge die 2010 OIE-regulasies onderneem word.

PROJEKBESKRYWING

BioTherm Energy (Edms.) Bpk. stel die oprigting voor van 'n driefase fotovoltaïese (FV) sonkragaanleg met 'n totale uitvoervermoë van 225 MW. Die voorgestelde projek sal bestaan uit drie FV-sonkragaanlegte met 'n totale uitvoervermoë van sowat 75 MW elk, wat as Helena Solar 1, 2 en 3 sal bekendstaan. Elke FV-sonkragaanleg sal uit sowat 300 000 FV-panele en gepaardgaande infrastruktuur bestaan. Die voorgestelde FV-sonkragaanlegte sal via 'n kraglyn van minder as 275 kV by die Kronos Substasie by die nasionale distribusienetwerk aansluit.

PROJEKLIIGING

Die voorgestelde projek is in die Noord-Kaapprovinsie, sowat 9 km suid van Copperton geleë. Dit is in die Siyathemba Plaaslike Munisipaliteit geleë wat deel vorm van die Pixley ka Seme Distriksmunisipaliteit. Die projek sluit die volgende plase in:

- Gedeelte 3 van die plaas Klipgatspan No. 117 (sonkragaanlegte)
- Gedeelte 4 van die plaas Klipgatspan No. 117 (kraglyn)

U word hiermee in kennis gestel dat SiVEST die tersaaklike Aansoekvorms by die DO ingedien het en dat die voorgestelde projekte onder die verwysingsnommers wat hierbo aangedui is, by die DO geregistreer is.

Ten einde as 'n Belangstellende en/of Geaffekteerde Party (B&GP) te registreer en/of om meer inligting te bekom, moet u asseblief u naam, kontakbesonderhede en die belang wat u by die aansoek het binne 30 dae vanaf die datum van hierdie kennisgewing indien.

Rig asseblief u **skriftelike** navrae aan die Omgewingskonsultante hieronder:

Andrea Gibb of Lynsey Rimbault	
SiVEST Environmental	
Posbus 2921	Tel: 011 798 0600
RIVONIA	Faks: 011 803 7272
2128	E-pos: andreag@sivest.co.za of lynseyr@sivest.co.za
	Webwerf: www.sivest.co.za

ENVIRONMENTAL IMPACT ASSESSMENT (EIA) AND ENVIRONMENTAL MANAGEMENT PROGRAMME (EMPr) FOR THE PROPOSED DEVELOPMENT OF THREE 75MW SOLAR PHOTOVOLTAIC (PV) ENERGY FACILITIES NEAR COPPERTON, NORTHERN CAPE PROVINCE

HELENA SOLAR 1 – DEA Ref No: 14/12/16/3/3/2/765

HELENA SOLAR 2 – DEA Ref No: 14/12/16/3/3/2/766

HELENA SOLAR 3 – DEA Ref No: 14/12/16/3/3/2/767

In terms of the National Environmental Management Act, 1998 (Act No. 107 of 1998) (NEMA) as amended and the Environmental Impact Assessment (EIA) Regulations, under Government Notices No R543, R544, R545 and R546 promulgated on 18 June 2010, Section 24 (5) read with section 44 of the NEMA, notice is hereby given that BioTherm Energy (Pty) Ltd has appointed SiVEST SA (Pty) Ltd, as the independent environmental assessment practitioner (EAP), to undertake the required EIA and public participation for the above-mentioned proposed projects in terms of the following listed activities:

Government Notice R544 (18 June 2010)								
Listing 1 Activity	(10)	(11)	(18)	(22)	(26)	(38)	(39)	(47)
Government Notice R545 (18 June 2010)								
Listing 2 Activity	(1)	(15)						
Government Notice R546 (18 June 2010)								
Listing 3 Activity	(4)	(12)	(13)	(14)	(16)	(19)		

Although new EIA Regulations were promulgated on 4 December 2014 and came into effect on 8 December 2014 (Government Gazette No. 38282), the application forms for the three proposed solar PV energy facilities were submitted to the Department of Environmental Affairs (DEA), prior to the 2014 EIA Regulations taking effect. In accordance with Regulation 53 (1) of the 2014 EIA Regulations, any applications submitted in terms of the previous NEMA regulations must be undertaken as if the previous NEMA regulations were not repealed. The EIA process will therefore be undertaken in accordance with the 2010 EIA Regulations.

PROJECT DESCRIPTION

BioTherm Energy (Pty) Ltd are proposing to construct a three phase solar photovoltaic (PV) energy facility with a total export capacity of 225MW. The proposed project will consist of three solar PV facilities with a total export capacity of approximately 75MW each, referred to as Helena Solar 1, 2 and 3. Each solar PV energy facility will consist of approximately 300 000 solar PV panels and associated infrastructure. The proposed solar PV facilities will connect with the national distribution network at Kronos substation via a power line of less than 275kV.

PROJECT LOCATION

The proposed project is located within the Northern Cape Province approximately 9km south of Copperton. It falls within the Siyathemba Local Municipality that forms part of the Pixley ka Seme District Municipality. The project includes the following farms:

- Portion 3 of the farm Klipgatspan No. 117 (solar facilities)
- Portion 4 of the farm Klipgatspan No. 117 (power line)

You are hereby informed that SiVEST has submitted the relevant Application Forms to the DEA and that the proposed projects are registered with them under the reference numbers listed above.

To register as an Interested and / or Affected Party (I&AP) and / or to obtain additional information please submit your name, contact details and the interest which you have in the application within 30 days from the date of this notice.

Please direct enquiries, **in writing**, to the Environmental Consultants below:

Andrea Gibb or Lynsey Rimbault	
SiVEST Environmental	
P O Box 2921	Tel: (011) 798 0600
RIVONIA	Fax: (011) 803 7272
2128	E-mail: andreag@sivest.co.za or lynseyr@sivest.co.za
	Website: www.sivest.co.za



**Appendix 5D:
Correspondence**

Andrea Gibb

From: Veronique Evans
Sent: Friday, March 06, 2015 8:36 AM
To: Andrea Gibb
Subject: FW: EIA Commencing for Three 75MW Solar PV Energy Facilities near Copperton

From: ThokoB [mailto:ThokoB@daff.gov.za]
Sent: 18 February 2015 03:57 PM
To: Veronique Evans
Subject: RE: EIA Commencing for Three 75MW Solar PV Energy Facilities near Copperton

Attention Veronique

This serves as confirmation of receipt of the email sent through for a Solar PV Energy Facility. I will forward your email to the Registry division for capturing and a formal acknowledgement letter of receipt will be sent to you once the garland agis system is back on.

I hope you find this in order.

Yours in service:

Thoko Buthelezi
Client Liaison Office
Tel: 012 319 7580
Fax: 012 329 5938
E-mail: thokob@daff.gov.za



BEFORE PRINTING THIS E-MAIL
please consider the environment

From: Veronique Evans [mailto:VeroniqueE@sivest.co.za]
Sent: 18 February 2015 07:57 AM
Cc: Andrea Gibb; Rebecca Thomas; Nicolene Venter (nicolenev@zitholele.co.za); Lynsey Rimbault
Subject: EIA Commencing for Three 75MW Solar PV Energy Facilities near Copperton

******* Please note that this email was sent from a NO REPLY email address. Please do not reply to this address as it is an unmonitored email account. *******

Dear Stakeholder

- Helena Solar 1 – DEA Ref No: 14/12/16/3/3/2/765
- Helena Solar 2 – DEA Ref No: 14/12/16/3/3/2/766
- Helena Solar 3 – DEA Ref No: 14/12/16/3/3/2/767

SIVEST SA (Pty) Ltd (hereafter referred to as SIVEST) has been appointed by BioTherm Energy (Pty) Ltd (hereafter referred to as BioTherm) to undertake the required Environmental Impact Assessment (EIA) process for the proposed development of a three phase solar photovoltaic (PV) energy facility with a total export capacity of 225MW, near Copperton within the Northern Cape Province. The proposed project will consist of three 75MW export capacity solar PV facilities referred to as Helena Solar 1, 2 and 3.

Please find attached, for your attention; the Background Information Document (BID), Invitation Letter and Registration and Comment Form for the proposed project. The documents are provided in English and Afrikaans for your convenience.

We look forward to receiving your comments.

Kind Regards

Andrea Gibb (B.Sc. Landscape Architecture; B.Sc.(Hons) Environmental Management)

Environmental Practitioner and Visual Specialist

SIVEST Environmental Division



SIVEST is a Level 3 BBBEE Contributor

Direct +27 11 798 0638 **Tel** +27 11 798 0600 **fax** +27 11 803 7272 **cell** +27 72 587 6525
email andrea@sivest.co.za **website** www.sivest.co.za



Consulting Engineers - Project Managers - Environmental Consultants - Town and Regional Planners
Durban - Johannesburg - Pietermaritzburg - Richards Bay - Ladysmith - Cape Town - Harare (Zimbabwe)

Disclaimer

The information contained in this communication from the sender is confidential. It is intended solely for use by the recipient and others authorized to receive it. If you are not the recipient, you are hereby notified that any disclosure, copying, distribution or taking action in relation of the contents of this information is strictly prohibited and may be unlawful.

This email has been scanned for viruses and malware, and automatically archived by **Mimecast SA (Pty) Ltd**, an innovator in Software as a Service (SaaS) for business. **Mimecast Unified Email Management ??? (UEM)** offers email continuity, security, archiving and compliance with all current legislation. To find out more, [contact Mimecast](#).

Andrea Gibb

From: Veronique Evans
Sent: Friday, March 06, 2015 8:36 AM
To: Andrea Gibb
Subject: FW: EIA Commencing for Three 75MW Solar PV Energy Facilities near Copperton
Attachments: Renewable Energy Generation Plant Setbacks to Eskom Infrastructure - Signed.pdf; Eskom requirements for work in or near Eskom servitudes SOLAR (3).doc

From: John Geeringh [mailto:GeerinJH@eskom.co.za]
Sent: 18 February 2015 01:28 PM
To: Veronique Evans
Subject: RE: EIA Commencing for Three 75MW Solar PV Energy Facilities near Copperton

Please find attached Eskom requirements for works at or near Eskom infrastructure. Please make sure these requirements are taken into consideration during the layout planning of your development.

Regards

John Geeringh (Pr Sci Nat)
Senior Consultant Environmental Management

Eskom GC: Land Development
Megawatt Park
D1Y39
P O Box 1091
Johannesburg
2000

Tel: 011 516 7233
Fax: 086 661 4064
Cell: 083 632 7663

From: Veronique Evans [mailto:VeroniqueE@sivest.co.za]
Sent: 18 February 2015 07:57 AM
Cc: Andrea Gibb; Rebecca Thomas; Nicolene Venter (nicolenev@zitholele.co.za); Lynsey Rimbault
Subject: EIA Commencing for Three 75MW Solar PV Energy Facilities near Copperton

******* Please note that this email was sent from a NO REPLY email address. Please do not reply to this address as it is an unmonitored email account. *******

Dear Stakeholder

- Helena Solar 1 – DEA Ref No: 14/12/16/3/3/2/765
- Helena Solar 2 – DEA Ref No: 14/12/16/3/3/2/766
- Helena Solar 3 – DEA Ref No: 14/12/16/3/3/2/767

SIVEST SA (Pty) Ltd (hereafter referred to as SiVEST) has been appointed by BioTherm Energy (Pty) Ltd (hereafter referred to as BioTherm) to undertake the required Environmental Impact Assessment (EIA) process for the proposed development of a three phase solar photovoltaic (PV) energy facility with a total export capacity of 225MW, near

Copperton within the Northern Cape Province. The proposed project will consist of three 75MW export capacity solar PV facilities referred to as Helena Solar 1, 2 and 3.

Please find attached, for your attention; the Background Information Document (BID), Invitation Letter and Registration and Comment Form for the proposed project. The documents are provided in English and Afrikaans for your convenience.

We look forward to receiving your comments.

Kind Regards

Andrea Gibb (B.Sc. Landscape Architecture; B.Sc.(Hons) Environmental Management)
Environmental Practitioner and Visual Specialist
SiVEST Environmental Division



SiVEST is a Level 3 BBBEE Contributor

Direct +27 11 798 0638 Tel +27 11 798 0600 fax +27 11 803 7272 cell +27 72 587 6525
email andrea@sivest.co.za website www.sivest.co.za



Consulting Engineers - Project Managers - Environmental Consultants - Town and Regional Planners
Durban - Johannesburg - Pietermaritzburg - Richards Bay - Ladysmith - Cape Town - Harare (Zimbabwe)

Disclaimer

The information contained in this communication from the sender is confidential. It is intended solely for use by the recipient and others authorized to receive it. If you are not the recipient, you are hereby notified that any disclosure, copying, distribution or taking action in relation of the contents of this information is strictly prohibited and may be unlawful.

This email has been scanned for viruses and malware, and automatically archived by **Mimecast SA (Pty) Ltd**, an innovator in Software as a Service (SaaS) for business. **Mimecast Unified Email Management ??? (UEM)** offers email continuity, security, archiving and compliance with all current legislation. To find out more, [contact Mimecast](#).

I'm part of the 49Million initiative.

<http://www.49Million.co.za>

NB: This Email and its contents are subject to the Eskom Holdings SOC Limited EMAIL LEGAL NOTICE which can be viewed at http://www.eskom.co.za/Pages/Email_Legal_Spam_Disclaimer.aspx

Eskom requirements for work in or near Eskom servitudes.

1. Eskom's rights and services must be acknowledged and respected at all times.
2. Eskom shall at all times retain unobstructed access to and egress from its servitudes.
3. Eskom's consent does not relieve the developer from obtaining the necessary statutory, land owner or municipal approvals.
4. Any cost incurred by Eskom as a result of non-compliance to any relevant environmental legislation will be charged to the developer.
5. If Eskom has to incur any expenditure in order to comply with statutory clearances or other regulations as a result of the developer's activities or because of the presence of his equipment or installation within the servitude restriction area, the developer shall pay such costs to Eskom on demand.
6. The use of explosives of any type within 500 metres of Eskom's services shall only occur with Eskom's previous written permission. If such permission is granted the developer must give at least fourteen working days prior notice of the commencement of blasting. This allows time for arrangements to be made for supervision and/or precautionary instructions to be issued in terms of the blasting process. It is advisable to make application separately in this regard.
7. Changes in ground level may not infringe statutory ground to conductor clearances or statutory visibility clearances. After any changes in ground level, the surface shall be rehabilitated and stabilised so as to prevent erosion. The measures taken shall be to Eskom's satisfaction.
8. Eskom shall not be liable for the death of or injury to any person or for the loss of or damage to any property whether as a result of the encroachment or of the use of the servitude area by the developer, his/her agent, contractors, employees, successors in title, and assignees. The developer indemnifies Eskom against loss, claims or damages including claims pertaining to consequential damages by third parties and whether as a result of damage to or interruption of or interference with Eskom's services or apparatus or otherwise. Eskom will not be held responsible for damage to the developer's equipment.
9. No mechanical equipment, including mechanical excavators or high lifting machinery, shall be used in the vicinity of Eskom's apparatus and/or services, without prior written permission having been granted by Eskom. If such permission is granted the developer must give at least seven working days' notice prior to the commencement of work. This allows time for arrangements to be made for supervision and/or precautionary instructions to be issued by the relevant Eskom Manager

Note: Where and electrical outage is required, at least fourteen work days are required to arrange it.

10. Eskom's rights and duties in the servitude shall be accepted as having prior right at all times and shall not be obstructed or interfered with.
11. Under no circumstances shall rubble, earth or other material be dumped within the servitude restriction area. The developer shall maintain the area concerned to Eskom's satisfaction. The developer shall be liable to Eskom for the cost of any remedial action which has to be carried out by Eskom.
12. The clearances between Eskom's live electrical equipment and the proposed construction work shall be observed as stipulated by *Regulation 15 of the Electrical Machinery Regulations of the Occupational Health and Safety Act, 1993 (Act 85 of 1993)*.
13. Equipment shall be regarded electrically live and therefore dangerous at all times.
14. In spite of the restrictions stipulated by Regulation 15 of the Electrical Machinery Regulations of the Occupational Health and Safety Act, 1993 (Act 85 of 1993), as an additional safety precaution, Eskom will not approve the erection of houses, or structures occupied or frequented by human beings, under the power lines or within the servitude restriction area.
15. Eskom may stipulate any additional requirements to highlight any possible exposure to Customers or Public to coming into contact or be exposed to any dangers of Eskom plant.
16. It is required of the developer to familiarise himself with all safety hazards related to Electrical plant.
17. Any third party servitudes encroaching on Eskom servitudes shall be registered against Eskom's title deed at the developer's own cost. If such a servitude is brought into being, its existence should be endorsed on the Eskom servitude deed concerned, while the third party's servitude deed must also include the rights of the affected Eskom servitude.

John Geeringh (Pr Sci Nat)

Senior Consultant Environmental Management
Eskom GC: Land Development

	<p style="text-align: center;">SCOT</p>	<p style="text-align: center;">Technology</p>
---	---	---

Title: **Renewable Energy Generation Plant Setbacks to Eskom Infrastructure** Unique Identifier: **240-65559775**

Alternative Reference Number: **N/A**

Area of Applicability: **Power Line Engineering**

Documentation Type: **Guideline**

Revision: **0**

Total Pages: **8**

Next Review Date: **N/A**

Disclosure Classification: **CONTROLLED DISCLOSURE**

Compiled by



J W Chetty
Mechanical Engineer

Date: 20/02/2014

Approved by



V Naidoo
Chief Engineer (Lines)

Date: 24/02/2014

Authorised by

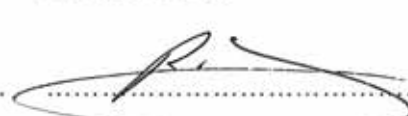

R A Vajeth
Acting Snr Manager (Lines)

Date: 27/2/2014

Supported by SCOT/SC



R Vajeth
SCOT/SC/ Chairperson

Date: 27/2/2014

PCM Reference: 240-65132732 **LINE ENGINEERING SERVICES**

SCOT Study Committee Number/Name : **OVERHEAD LINES**

CONTENTS

	Page
EXECUTIVE SUMMARY	3
1. INTRODUCTION.....	4
2. SUPPORTING CLAUSES	4
2.1 SCOPE	4
2.1.1 Purpose.....	4
2.1.2 Applicability	5
2.2 NORMATIVE/INFORMATIVE REFERENCES	5
2.2.1 Normative.....	5
2.2.2 Informative	5
2.3 DEFINITIONS	5
2.3.1 Disclosure Classification.....	6
2.4 ABBREVIATIONS	6
2.5 ROLES AND RESPONSIBILITIES	6
2.6 PROCESS FOR MONITORING	6
2.7 RELATED/SUPPORTING DOCUMENTS	6
3. DOCUMENT CONTENT	6
3.1 INTERNATIONAL SETBACK COMPARISON	6
3.2 ESKOM APPROACH FOR WIND FARMS	7
4. AUTHORISATION	8
5. REVISIONS.....	8
6. DEVELOPMENT TEAM	9

FIGURES

Figure 1: Horizontal Axis Wind Turbine	8
--	---

CONTROLLED DISCLOSURE

When downloaded from the EDMS, this document is uncontrolled and the responsibility rests with the user to ensure it is in line with the authorised version on the system

EXECUTIVE SUMMARY

In recent decades, the use of wind turbines, concentrated solar plants and photovoltaic plants have been on the increase as it serves as an abundant source of energy. This document specifies setbacks for wind turbines and the reasons for these setbacks from infrastructure as well as setbacks for concentrated solar plants and photovoltaic plants. Setbacks for wind turbines employed in other countries were compared and a general setback to be used by Eskom was suggested for use with wind turbines and other renewable energy generation plants.

CONTROLLED DISCLOSURE

When downloaded from the EDMS, this document is uncontrolled and the responsibility rests with the user to ensure it is in line with the authorised version on the system.

1. INTRODUCTION

During the last few decades, a large amount of wind turbines have been installed in wind farms to accommodate for the large demand of energy and depleting fossil fuels. Wind is one of the most abundant sources of renewable energy. Wind turbines harness the energy of this renewable resource for integration in electricity networks. The extraction of wind energy is its primary function and thus the aerodynamics of the wind turbine is important. There are many different types of wind turbines which will all exhibit different wind flow characteristics. The most common wind turbine used commercially is the Horizontal Axis Wind Turbine. Wind flow characteristics of this turbine are important to analyse as it may have an effect on surrounding infrastructure.

Wind turbines also cause large turbulence downwind that may affect existing infrastructure. Debris or parts of the turbine blade, in the case of a failure, may be tossed behind the turbine and may lead to damage of infrastructure in the wake path.

This document outlines the minimum distances that need to be introduced between a wind turbine and Eskom infrastructure to ensure that debris and / or turbulence would not negatively impact on the infrastructure.

Safety distances of wind turbines from other structures as implemented by other countries were also considered and the reasons for their selection were noted.

Concentrated solar plants and photovoltaic plants setbacks away from substations were also to be considered to prevent restricting possible power line access routes to the substation.

2. SUPPORTING CLAUSES

2.1 SCOPE

This document provides guidance on the safe distance that a wind turbine should be located from any Eskom power line or substation. The document specifies setback distances for transmission lines (220 kV to 765 kV), distribution lines (6.6 kV to 132 kV) and all Eskom substations. Setbacks for concentrated solar plants and photovoltaic plants are also specified away from substations.

2.1.1 Purpose

Setbacks for wind turbines and power lines / substations are required for various reasons. These include possible catastrophic failure of the turbine blade that may release fragments and which may be thrown onto nearby power lines that may result in damage with associated unplanned outages. Turbulence behind the turbine may affect helicopter flight during routine Eskom live line maintenance and

CONTROLLED DISCLOSURE

When downloaded from the EDMS, this document is uncontrolled and the responsibility rests with the user to ensure it is in line with the authorised version on the system.

inspections that may lead to safety risk of the aircraft / personnel. Concentrated solar plants and photovoltaic plants setback away from substations were required to prevent substations from being boxed in by these renewable generation plants limiting line route access to the substations.

2.1.2 Applicability

This document is applicable to the siting of all new and existing wind turbines, concentrated solar plants and photovoltaic plants near power lines and substations.

2.2 NORMATIVE/INFORMATIVE REFERENCES

2.2.1 Normative

1. <http://www.envir.ee/orb.aw/class=file/action=preview/id=1170403/Hiiumaa+turbulence+impact+EMD.pdf>.
2. <http://www.energy.ca.gov/2005publications/CEC-500-2005-184/CEC-500-2005-184.PDF>
3. <http://www.adamscountywind.com/Revised%20Site/Windmills/Adams%20County%20Ordinance/Adams%20County%20Wind%20Ord.htm>
4. http://www.dsireusa.org/incentives/incentive.cfm?Incentive_Code=PA11R&RE=1&EE=1
5. <http://www.wind-watch.org/documents/european-setbacks-minimum-distance-between-wind-turbines-and-habitations/>
6. <http://www.publications.parliament.uk/pa/ld201011/ldbills/017/11017.1-i.html>
7. http://www.caw.ca/assets/pdf/Turbine_Safety_Report.pdf
8. Rogers J, Slegers N, Costello M. (2011) A method for defining wind turbine setback standards. Wind energy 10.1002/we.468

2.2.2 Informative

None

2.3 DEFINITIONS

Definition	Description
Setback	The minimum distance between a wind turbine and boundary line/dwelling/road/infrastructure/servitude etc.
Flicker	Effect caused when rotating wind turbine blades periodically cast shadows
Tip Height	The total height of the wind turbine ie. Hub height plus half rotor diameter (see Figure 1)

CONTROLLED DISCLOSURE

When downloaded from the EDMS, this document is uncontrolled and the responsibility rests with the user to ensure it is in line with the authorised version on the system.

2.3.1 Disclosure Classification

Controlled disclosure: controlled disclosure to external parties (either enforced by law, or discretionary).

2.4 ABBREVIATIONS

Abbreviation	Description
None	

2.5 ROLES AND RESPONSIBILITIES

All personnel involved in the positioning wind turbines, concentrated solar plants and photovoltaic plants near power lines/substations must follow the setbacks outlined in this guideline.

2.6 PROCESS FOR MONITORING

Approval by Eskom in writing.

2.7 RELATED/SUPPORTING DOCUMENTS

None

3. DOCUMENT CONTENT

3.1 INTERNATIONAL SETBACK COMPARISON

Wind Turbine setbacks employed by various countries were considered. It was found that setbacks were determined for various reasons that include noise, flicker, turbine blade failure and wind effects. The distances (setbacks) varied based on these factors and were influenced by the type of infrastructure

Wind turbine setbacks varied for roads, power lines, dwellings, buildings and property and it was noted that the largest setbacks were employed for reasons of noise and flicker related issues [1-7]. Very few countries specified setbacks for power lines.

The literature survey [1-7], yielded information about studies and experiments were conducted to determine the distance that a broken fragment from a wind turbine might be thrown. Even though of low probability of hitting a power line [5.0×10^{-5}]^[8], the distances recorded were significant [750m]^[8]

Setbacks were thus introduced to prevent any damage to Eskom infrastructure.

CONTROLLED DISCLOSURE

When downloaded from the EDMS, this document is uncontrolled and the responsibility rests with the user to ensure it is in line with the authorised version on the system.

Wind turbines may also cause changes in wind patterns with turbulent effects behind the hub. These factors dictate the wind turbine setbacks specified in this document.

Concentrated solar plants and photovoltaic plants also can limit access into the substation for power lines of all voltages. A setback distance must therefore be employed to prevent the substation from being boxed in by these generation plants. These setback distances are specified in this document.

3.2 ESKOM REQUIRED SETBACKS

- Eskom requires a setback distance of 3 times the tip height of the wind turbine from the edge of the closest Eskom servitude (including vacant servitudes) for transmission lines.
- Eskom requires a setback distance of 1 times the tip height of the wind turbine from the edge of the closest Eskom servitude (including vacant servitudes) for distribution Lines.
- Eskom must be informed of any proposed wind turbine, concentrated solar plants and photovoltaic activity within a 5 km radius of a substation. No wind turbine structure shall be built within a 2 km radius of the closest point of the substation. Where concentrated solar plants and photovoltaic structures fall within a 2 km radius of the closest point of a substation, Eskom should be informed in writing during the planning phase of the construction of such plant or structure.
- Applicants must show that Eskom radio telecommunication systems (mainly microwave systems) will not be affected in any way by wind turbines.

CONTROLLED DISCLOSURE

When downloaded from the EDMS, this document is uncontrolled and the responsibility rests with the user to ensure it is in line with the authorised version on the system.

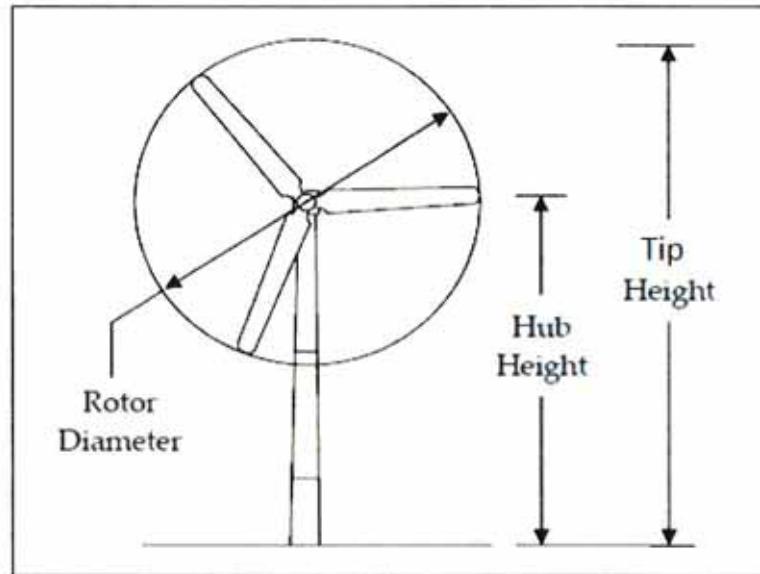

Figure 1: Horizontal Axis Wind Turbine [2]

4. AUTHORISATION

This document has been seen and accepted by:

Name & Surname	Designation
V Naidoo	Chief Engineer
Dr P H Pretorius	Electrical Specialist
J Geeringh	Snr Consultant Environ Mngt
B Haridass	Snr Consultant Engineer
R A Vajeth	Acting Snr Manager (Lines)

5. REVISIONS

Date	Rev.	Compiler	Remarks
November 2013	0	J W Chetty	First Publication - No renewable energy generation plant setback specification in existence

CONTROLLED DISCLOSURE

When downloaded from the EDMS, this document is uncontrolled and the responsibility rests with the user to ensure it is in line with the authorised version on the system.

6. DEVELOPMENT TEAM

The following people were involved in the development of this document:

Jonathan W Chetty (Mechanical Engineer)

Vivendhra Naidoo (Chief Engineer)

Dr Pieter H Pretorius (Electrical Specialist)

John Geeringh (Snr Consultant Environ Mngt)

Bharat Haridass (Snr Consultant Engineer)

Riaz A Vajeth (Acting Snr Manager (Lines))

CONTROLLED DISCLOSURE

When downloaded from the EDMS, this document is uncontrolled and the responsibility rests with the user to ensure it is in line with the authorised version on the system.



agriculture, forestry & fisheries

Department:
Agriculture, Forestry and Fisheries
REPUBLIC OF SOUTH AFRICA

Directorate: Forestry Management (Other Regions)
P.O. Box 2782, Upington, 8800, Tel 054 338 5909, Fax 054 334 0030

Enquiries: J Mans
E-mail: jacomm@daff.gov.za
Date: 19 February 2015
Ref: F13/11/2/301

SiVEST
P.O. Box 2921
RIVONIA
2128

ATTENTION: Ms. Andrea Gibb (andreas@sivest.co.za)

RE: COMMENTS ON BACKGROUND INFORMATION DOCUMENT OF THE PROPOSED THREE 75MW HELENA SOLAR 1, 2 AND 3 (DEA REF: 14/12/16/3/3/2/765, 766 AND 767) ENERGY FACILITIES NEAR COPPORTON, NORTHERN CAPE

1. DEPARTMENTAL MANDATE

- 1.1** The Directorate: Forestry Management (Other Regions) in the Department of Agriculture, Forestry and Fisheries (DAFF) is mainly concerned about the potential impact on protected tree species. See the National Forests Act, Act 84 of 1998 (NFA) as amended, section 12(1)(d) read with s15(1) and s62(2)(c). The most recent list of protected tree species was published in GN 908 of 21 November 2014. **No protected tree may be damaged, disturbed, cut or destroyed without a valid Forest Act license, irrespective of other authorisations and approvals.**
- 1.2** The DAFF is also responsible for the administration of the National Veld and Forest Fires Act, Act 101 of 1998 (NVFFA) as amended. Please take note of roles and responsibilities in terms of the NVFFA.

2. COMMENTS ON BACKGROUND INFORMATION DOCUMENT

- 2.1** Kindly ensure that you assess the potential impact on NFA listed protected tree species (if any) and provide a copy of the biodiversity specialist report to this office for comments.

Kind Regards,

J Mans
Jacoline Mans

Chief Forester: NFA Regulation

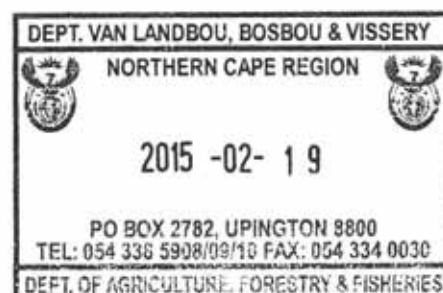

EIA AND EMP_r FOR THE PROPOSED DEVELOPMENT OF THREE 75MW SOLAR PHOTOVOLTAIC (PV) ENERGY FACILITIES NEAR COPPERTON, NORTHERN CAPE PROVINCE

- HELENA SOLAR 1 – DEA Ref No: 14/12/16/3/3/2/765
- HELENA SOLAR 2 – DEA Ref No: 14/12/16/3/3/2/766
- HELENA SOLAR 3 – DEA Ref No: 14/12/16/3/3/2/767

REGISTRATION AND COMMENT FORM

Accompanying Background Information Document: 18 February 2015



Public Participation Office



Andrea Gibb / Lynsey Rimbault
 SiVEST Environmental
 PO Box 2921, RIVONIA, 2128
 Tel (011) 798 0600
 Fax (011) 803 7272
 Email andreag@sivest.co.za /
 lynseyr@sivest.co.za

Please complete by Thursday 19 March 2015, and return by post, fax or e-mail to the Public Participation Office (as above)

TITLE	Ms	FIRST NAME	Jacoline Mans
INITIALS	J	SURNAME	Mans
ORGANISATION	DAFF	EMAIL	Jacoline.Mae.daff.gov.za
POSTAL ADDRESS	PO Box 2782		
	Upington	POSTAL CODE	8800
TEL NO	054 338 5909	FAX NO	054 334 0030

REGISTRATION AS INTERESTED AND/OR AFFECTED PARTY (I&AP) (please circle applicable box)

Please formally register me as an interested and affected party (I&AP) so that I may receive further information and notifications during the EIA process	YES <input checked="" type="checkbox"/>	NO <input type="checkbox"/>
In terms of GNR 543 (2010 EIA regulations) I disclose below any direct business, financial, personal or other interest that I may have in the granting or rejection of the application for environmental authorisation (please use separate sheets if you wish):		
No interest.....		

COMMENTS (please use separate sheets if you wish)

I suggest that the following issues of concern be investigated in the EIA:

Potential impacts on NFA Listed Protected Tree Species (if any).....

I suggest the following for the EIA process and / or the public participation process:

Any other comments:

Please contact the following colleagues/friends to register as I&APs for this EIA (name and contact details e.g. e-mail address):

J. Mans
Signature

THANK YOU FOR YOUR CONTRIBUTION

19/02/2015
Date



17 Baker Street
Rosebank
Johannesburg
South Africa
2196

Tel: +27 (0) 11 442 2434
Fax: +27 (0) 11 442 2454
Email: atiplady@ska.ac.za

Andrea Gibb
Environmental Practitioner and Visual Specialist
SiVEST Environmental Division
PO Box 2921
Rivonia
2128

E-mail: andrea@sivest.co.za

Date: 23 February 2015

Dear Andrea,

Re: Development of three 75MW Solar PV Energy Facilities (Helena Solar 1-3) near Copperton in the Northern Cape Province.

This letter is in response to your email request, to provide an assessment on the potential development of three 75MW solar electricity generation facilities in the Northern Cape Province and the risk they may pose on the Square Kilometre Array Project.

A high level risk assessment has been conducted at the South African SKA Project Office to determine the potential impact of such facilities on the Square Kilometre Array. This letter serves to confirm the outcomes of the risk assessment, and proposals for any future investigations associated with this facility.

- I. The location of the proposed facility has been provided in the background information document compiled by SiVEST Environmental Division,
- II. The nearest SKA station has been identified SKA-Ant-190, at approximately 23km from the proposed installation at Klipgatspan;
- III. Based on distance to the nearest SKA station, detailed design of the solar installation, and the cumulative impact of multiple renewable energy facilities of a similar nature in the same vicinity, the proposed facilities poses a **high** risk of detrimental impact on the SKA;
- IV. Any transmitters that are to be established, or have been established, at the site for the purposes of voice and data communication will be required to comply with the relevant AGA regulations concerning the restriction of use of the radio frequency spectrum that applies in the area concerned;
- V. As a result of the **high** risk associated with these facilities, The SKA project office recommends that further detailed EMI and RFI detailed studies be conducted as significant mitigation measures would be required to lower the risk of detrimental impact to an acceptable level. It is not guaranteed that sufficient mitigation measures would be available. The South African SKA Project Office would like to



be kept informed of progress with this project, and reserves the right to further risk assessments at a later stage.

This technical advice is provided by the South African SKA Project Office on the basis of the protection requirements of the SKA in South Africa, and does not constitute legal approval of the renewable energy projects in terms of the Astronomy Geographic Advantage Act, the Management Authority, and its regulations or declarations.

Regards,

Dr. Adrian Tiplady
South African SKA Site Bid Manager
SKA South Africa
Tel: 011 442 2434
Fax: 011 442 2454
atiplady@ska.ac.za

Andrea Gibb

From: Simphiwe Masilela <SimphiweM@atns.co.za>
Sent: Thursday, February 26, 2015 8:21 AM
To: Veronique Evans; Andrea Gibb
Subject: RE: EIA Commencing for Three 75MW Solar PV Energy Facilities near Copperton



Good day Andrea,

[RE: EIA Commencing for Three 75MW Solar PV Energy Facilities near Copperton](#)

Please note that ATNS is aware of the above mentioned.

We might not be able to attend some if not all your public meetings, however we request that you please update us should there be any new developments that may affect our interests. We will duly conduct assessments as required when the project is ready for construction.

Looking forward to working with you further,

Kind Regards,

Simphiwe Masilela
Obstacle Evaluator | ATM
ATNS Head Office, Bruma, Johannesburg, South Africa

T: 011 607 1228 • F: 011 607 1466 • C:
E: SimphiweM@atns.co.za • W: www.atns.co.za



[View Disclaimer](#)

From: Veronique Evans [<mailto:VeroniqueE@sivest.co.za>]
Sent: 18 February 2015 07:57
To: undisclosed-recipients
Cc: Andrea Gibb; Rebecca Thomas; Nicolene Venter (nicolenev@zitholele.co.za); Lynsey Rimbault
Subject: EIA Commencing for Three 75MW Solar PV Energy Facilities near Copperton

******* Please note that this email was sent from a NO REPLY email address. Please do not reply to this address as it is an unmonitored email account. *******

Dear Stakeholder

- Helena Solar 1 – DEA Ref No: 14/12/16/3/3/2/765
- Helena Solar 2 – DEA Ref No: 14/12/16/3/3/2/766
- Helena Solar 3 – DEA Ref No: 14/12/16/3/3/2/767

SiVEST SA (Pty) Ltd (hereafter referred to as SiVEST) has been appointed by BioTherm Energy (Pty) Ltd (hereafter referred to as BioTherm) to undertake the required Environmental Impact Assessment (EIA) process for the proposed development of a three phase solar photovoltaic (PV) energy facility with a total export capacity of 225MW, near Copperton within the Northern Cape Province. The proposed project will consist of three 75MW export capacity solar PV facilities referred to as Helena Solar 1, 2 and 3.

Please find attached, for your attention; the Background Information Document (BID), Invitation Letter and Registration and Comment Form for the proposed project. The documents are provided in English and Afrikaans for your convenience.

We look forward to receiving your comments.

Kind Regards

Andrea Gibb (B.Sc. Landscape Architecture; B.Sc.(Hons) Environmental Management)

Environmental Practitioner and Visual Specialist

SiVEST Environmental Division



SiVEST is a Level 3 BBBEE Contributor

Direct +27 11 798 0638 Tel +27 11 798 0600 fax +27 11 803 7272 cell +27 72 587 6525
email andrea@sivest.co.za website www.sivest.co.za



Consulting Engineers - Project Managers - Environmental Consultants - Town and Regional Planners
Durban - Johannesburg - Pietermaritzburg - Richards Bay - Ladysmith - Cape Town - Harare (Zimbabwe)

Disclaimer

The information contained in this communication from the sender is confidential. It is intended solely for use by the recipient and others authorized to receive it. If you are not the recipient, you are hereby notified that any disclosure, copying, distribution or taking action in relation of the contents of this information is strictly prohibited and may be unlawful.

This email has been scanned for viruses and malware, and automatically archived by **Mimecast SA (Pty) Ltd**, an innovator in Software as a Service (SaaS) for business. **Mimecast Unified Email Management ??? (UEM)** offers email continuity, security, archiving and compliance with all current legislation. To find out more, [contact Mimecast](#).

The contents of this email are confidential and intended for the named recipient(s) only. The information may be privileged or otherwise protected from disclosure. The views expressed in this message are those of the sender, unless otherwise stated to be. This email is also subject to copyright. No part hereof may be reproduced, adapted, transmitted, or used in any way without the written consent of ATNS SOC Limited. Please do not hesitate to contact us immediately should you have any doubts regarding the authenticity of an email purportedly sent by the sender.



**NETWORK INFRASTRUCTURE PROVISIONING
WAYLEAVE MANAGEMENT
CENTRAL REGION**

**Telkom SA SOC Limited
Private Bag X20700
BLOEMFONTEIN
9300**

Enquiries: Chris Schutte
Telephone: 051 - 401 6701
Fax : 088 0514016238
e-mail : WayleaCR@telkom.co.za

Our Ref no: CCPN0096-15

Your ref: 14/12/16/3/3/2/765

27 February 2015

SIVEST
P.O. Box 2921
RIVONIA
2128

EIA COMMENCING FOR THREE 75MW SOLAR PV ENERGY FACILITIES NEAR COPPERTON

Your letter received on the 18 February 2015.

With reference to your above-mentioned application, I hereby inform you that Telkom SA SOC LTD approves the proposed work indicated on your drawings in terms of Section 23 of the Electronic Communication Act No. 36 of 2005 as amended.

No Telkom SA SOC Ltd infrastructure will be affected by this proposal.

Although we are not affected by this proposal, Mr Petrus Fourie must be contacted at 081 363 5213 from our Network Field Services before commencement of work.

Approval of the proposed route is valid for six months. If construction has not yet commenced within this period, then the file must be resubmitted for approval

Any changes/deviations from the original planning during or prior to construction must immediately be communicated to this office.

As per supplied sketches it would appear as if Telkom SA SOC Ltd infrastructure would not be affected. However, care should still be taken should it become evident that there is in fact Telkom SA SOC LTD network present at the actual sites. Such lines should be treated in accordance with, and clearances stipulated in the occupational Health and Safety Act no. 85 of 1993, Electrical Machinery regulations 20 – Crossings, and Electrical Machinery Regulations 15 – Clearance Power Lines. If the specifications could not be met, all deviations costs will be for applicant's account. We also refer to section 25 of the Electronic Communication Act 36 of 2005

Application approved on condition that, should it later be found necessary to deviate the existing communication line due to existing noise interference or any other reason whatsoever, the cost of such remedial action shall be repayable.

On completion of this project, please certify that all requirements as stipulated in this letter have been met. Please note that should any of Telkom SA SOC LTD infrastructure has to be relocated or altered as a result of your activities the cost for such alteration or relocation will be for your account in terms of section 25 of the Electronic Communication Act.

Although we are not affected by this proposal, Mr Petrus Fourie must be contacted at 081 363 5213 from our Network Field Services before commencement of work.

Please notify this office and forward an as built plan, within 30 days of completion of construction.

Should Telkom SA SOC Ltd infrastructure be damaged while work is undertaken, kindly call the Toll free number – 0800203957 – immediately.

Yours sincerely

HELEEN VAN DEN HEEVER

Andrea Gibb

From: René de Kock (WR) <Dekockr@nra.co.za>
Sent: Tuesday, May 12, 2015 3:01 PM
To: Andrea Gibb
Subject: RE: Helena PV Energy Facilities near Copperton: Public Meeting Invite

Andrea,

Thank you for your email.

Please forward me a locality map in relation to the site and the national road. I need to make sure if SANRAL is affected or not.

Kind regards



Ms René de Kock

Statutory Control

Tel: +27 21 957 4607

Fax: +21 946 1630

Cell:

Email: Dekockr@nra.co.za



**Are you ready?
Get tagged**

Western Region

1 Havenga Street Oakdale Bellville

Private Bag X19

www.nra.co.za

SANRAL Fraud Hotline: 0800204558

From: Andrea Gibb [mailto:AndreaG@sivest.co.za]
Sent: 12 May 2015 02:14 PM
Cc: Nicolene Venter (nicolenev@zitholele.co.za); Lynsey Rimbault
Subject: Helena PV Energy Facilities near Copperton: Public Meeting Invite

Dear Stakeholder

Attached herewith is your invitation and draft agenda for the Public Meeting that will be held on **Thursday 21 May 2015** at the Omega Hall, Bonteheuwel, Prieska at 16h30.

Kindly complete the attached Registration Form and return it to us before **Tuesday 19 May 2015**.

Kind Regards

Beste Rolspeler

Aangeheg is u uitnodiging en konsep agenda vir die Publiekevergadering wat op **Donderdag 21 Mei 2015** by Omega Hall, Bonteheuwel, Prieska om 16h30 gehou word.

U word vriendelik versoek om die aangehegde Registrasievorm te voltooi en aan ons deur te stuur voor of op
Dinsdag 19 Mei 2015.

Vriendelike groete

Kind Regards

Andrea Gibb (B.Sc. Landscape Architecture; B.Sc.(Hons) Environmental Management)

Environmental Practitioner and Visual Specialist

SiVEST Environmental Division



SiVEST is a Level 3 BBBEE Contributor

Direct +27 11 798 0638 Tel +27 11 798 0600 fax +27 11 803 7272 cell +27 72 587 6525

email andrea@sivest.co.za website www.sivest.co.za



Consulting Engineers - Project Managers - Environmental Consultants - Town and Regional Planners
Durban - Johannesburg - Pietermaritzburg - Richards Bay - Ladysmith - Cape Town - Harare (Zimbabwe)

Disclaimer

The information contained in this communication from the sender is confidential. It is intended solely for use by the recipient and others authorized to receive it. If you are not the recipient, you are hereby notified that any disclosure, copying, distribution or taking action in relation of the contents of this information is strictly prohibited and may be unlawful.

This email has been scanned for viruses and malware, and automatically archived by **Mimecast SA (Pty) Ltd**, an innovator in Software as a Service (SaaS) for business. **Mimecast Unified Email Management ??? (UEM)** offers email continuity, security, archiving and compliance with all current legislation. To find out more, [contact Mimecast](#).

Disclaimer:

This message contains confidential information and is intended only for the individual named.

If you are not the named addressee you should not disseminate, distribute or copy this e-mail.

Please notify the sender immediately by e-mail if you have received this e-mail by mistake and delete this e-mail from your system. E-mail transmission cannot be guaranteed to be secure or without errors as information could be intercepted, corrupted, lost, destroyed, arrive late or incomplete, or contain viruses.

The sender therefore does not accept liability for any errors or omissions in the contents of this message, which arise as a result of e-mail transmission.

If verification is required please request a hard-copy version. The South African National Roads Agency SOC Ltd, PO Box 415, Pretoria, 0001, South Africa, Tel +27-(0)12 844 8000, www.nra.co.za.

This Disclaimer is deemed to form part of the content of this email in terms of Section 11 of the Electronic Communications and Transactions Act, 25 of 2002.

Andrea Gibb

From: René de Kock (WR) <Dekockr@nra.co.za>
Sent: Friday, May 15, 2015 1:07 PM
To: Andrea Gibb
Cc: Colene Runkel (WR)
Subject: RE: Helena PV Energy Facilities near Copperton: Public Meeting Invite

Andrea,

Thank you for your email.

The South African National Roads Agency SOC Limited (SANRAL) has no comment with regard to the above solar energy facilities near Copperton, as this will not affect the national road.

Kind regards



Ms René de Kock

Statutory Control

Tel: +27 21 957 4607

Fax: +21 946 1630

Cell:

Email: Dekockr@nra.co.za



**Are you ready?
Get tagged**

Western Region

1 Havenga Street Oakdale Bellville

Private Bag X19

www.nra.co.za

SANRAL Fraud Hotline: 0800204558

From: Andrea Gibb [mailto:AndreaG@sivest.co.za]
Sent: 13 May 2015 07:58 AM
To: René de Kock (WR)
Subject: RE: Helena PV Energy Facilities near Copperton: Public Meeting Invite

Hi René

Attached is the site locality map. As indicated on the map, no national roads are located within close proximity to the proposed development.

Kind Regards

Andrea Gibb (B.Sc. Landscape Architecture; B.Sc.(Hons) Environmental Management)

Environmental Practitioner and Visual Specialist

SiVEST Environmental Division



SiVEST is a Level 3 BBBEE Contributor

Direct +27 11 798 0638 **Tel** +27 11 798 0600 **fax** +27 11 803 7272 **cell** +27 72 587 6525
email andrea@sivest.co.za **website** www.sivest.co.za



From: René de Kock (WR) [<mailto:Dekockr@nra.co.za>]
Sent: Tuesday, May 12, 2015 3:01 PM
To: Andrea Gibb
Subject: RE: Helena PV Energy Facilities near Copperton: Public Meeting Invite

Andrea,

Thank you for your email.

Please forward me a locality map in relation to the site and the national road. I need to make sure if SANRAL is affected or not.

Kind regards



Ms René de Kock

Statutory Control

Tel: +27 21 957 4607

Fax: +21 946 1630

Cell:

Email: Dekockr@nra.co.za



**Are you ready?
Get tagged**

Western Region

1 Havenga Street Oakdale Bellville

Private Bag X19

www.nra.co.za

SANRAL Fraud Hotline: 0800204558

From: Andrea Gibb [<mailto:AndreaG@sivest.co.za>]
Sent: 12 May 2015 02:14 PM
Cc: Nicolene Venter (nicolenev@zitholele.co.za); Lynsey Rimbault
Subject: Helena PV Energy Facilities near Copperton: Public Meeting Invite

Dear Stakeholder

Attached herewith is your invitation and draft agenda for the Public Meeting that will be held on **Thursday 21 May 2015** at the Omega Hall, Bonteheuwel, Prieska at 16h30.

Kindly complete the attached Registration Form and return it to us before **Tuesday 19 May 2015**.

Kind Regards

Beste Rolspeler

Aangeheg is u uitnodiging en konsep agenda vir die Publiekevergadering wat op **Donderdag 21 Mei 2015** by Omega Hall, Bonteheuwel, Prieska om 16h30 gehou word.

U word vriendelik versoek om die aangehegde Registrasievorm te voltooi en aan ons deur te stuur voor of op **Dinsdag 19 Mei 2015**.

Vriendelike groete

Kind Regards

Andrea Gibb (B.Sc. Landscape Architecture; B.Sc.(Hons) Environmental Management)
Environmental Practitioner and Visual Specialist
SiVEST Environmental Division



SiVEST is a Level 3 BBBEE Contributor

Direct +27 11 798 0638 Tel +27 11 798 0600 fax +27 11 803 7272 cell +27 72 587 6525
email andrea@sivest.co.za website www.sivest.co.za



Consulting Engineers - Project Managers - Environmental Consultants - Town and Regional Planners
Durban - Johannesburg - Pietermaritzburg - Richards Bay - Ladysmith - Cape Town - Harare (Zimbabwe)

Disclaimer

The information contained in this communication from the sender is confidential. It is intended solely for use by the recipient and others authorized to receive it. If you are not the recipient, you are hereby notified that any disclosure, copying, distribution or taking action in relation of the contents of this information is strictly prohibited and may be unlawful.

This email has been scanned for viruses and malware, and automatically archived by **Mimecast SA (Pty) Ltd**, an innovator in Software as a Service (SaaS) for business. **Mimecast Unified Email Management ??? (UEM)** offers email continuity, security, archiving and compliance with all current legislation. To find out more, [contact Mimecast](#).

Disclaimer:

This message contains confidential information and is intended only for the individual named.

If you are not the named addressee you should not disseminate, distribute or copy this e-mail.

Please notify the sender immediately by e-mail if you have received this e-mail by mistake and delete this e-mail from your system. E-mail transmission cannot be guaranteed to be secure or without errors as information could be intercepted, corrupted, lost, destroyed, arrive late or incomplete, or contain viruses.

The sender therefore does not accept liability for any errors or omissions in the contents of this message, which arise as a result of e-mail transmission.

If verification is required please request a hard-copy version. The South African National Roads Agency SOC Ltd, PO Box 415, Pretoria, 0001, South Africa, Tel +27-(0)12 844 8000, www.nra.co.za.

This Disclaimer is deemed to form part of the content of this email in terms of Section 11 of the Electronic Communications and Transactions Act, 25 of 2002.

Disclaimer

The information contained in this communication from the sender is confidential. It is intended solely for use by the recipient and others authorized to receive it. If you are not the recipient, you are hereby notified that any disclosure, copying, distribution or taking action in relation of the contents of this information is strictly prohibited and may be unlawful.

This email has been scanned for viruses and malware, and automatically archived by **Mimecast SA (Pty) Ltd**, an innovator in Software as a Service (SaaS) for business. **Mimecast Unified Email Management ??? (UEM)** offers email continuity, security, archiving and compliance with all current legislation. To find out more, [contact Mimecast](#).

Disclaimer:

This message contains confidential information and is intended only for the individual named.

If you are not the named addressee you should not disseminate, distribute or copy this e-mail.

Please notify the sender immediately by e-mail if you have received this e-mail by mistake and delete this e-mail from your system. E-mail transmission cannot be guaranteed to be secure or without errors as information could be intercepted, corrupted, lost, destroyed, arrive late or incomplete, or contain viruses.

The sender therefore does not accept liability for any errors or omissions in the contents of this message, which arise as a result of e-mail transmission. If verification is required please request a hard-copy version. The South African National Roads Agency SOC Ltd, PO Box 415, Pretoria, 0001, South Africa, Tel +27-(0)12 844 8000, www.nra.co.za.

This Disclaimer is deemed to form part of the content of this email in terms of Section 11 of the Electronic Communications and Transactions Act, 25 of 2002.

Andrea Gibb

From: WESSA Northern Cape <wessanc@yahoo.com>
Sent: Sunday, May 17, 2015 6:54 PM
To: Andrea Gibb
Cc: Nicolene Venter (nicolenev@zitholele.co.za); Lynsey Rimbault
Subject: Re: Helena PV Energy Facilities near Copperton: Public Meeting Invite

WESSA in the Northern Cape is not able to deal with these matters.

Please do not send faxes or hard copies of documents to us. They will be destroyed. Registered mail will NOT be collected.

Please consult the website for other WESSA contact details, or direct your e-mail to info@wessa.co.za or info@wessanorth.co.za

From: Andrea Gibb <AndreaG@sivest.co.za>
To:
Cc: "Nicolene Venter (nicolenev@zitholele.co.za)" <nicolenev@zitholele.co.za>; Lynsey Rimbault <LynseyR@sivest.co.za>
Sent: Tuesday, 12 May 2015, 14:13
Subject: Helena PV Energy Facilities near Copperton: Public Meeting Invite

Dear Stakeholder

Attached herewith is your invitation and draft agenda for the Public Meeting that will be held on **Thursday 21 May 2015** at the Omega Hall, Bonteheuwel, Prieska at 16h30.
Kindly complete the attached Registration Form and return it to us before **Tuesday 19 May 2015**.

Kind Regards

Beste Rolspeler

Aangeheg is u uitnodiging en konsep agenda vir die Publiekevergadering wat op **Donderdag 21 Mei 2015** by Omega Hall, Bonteheuwel, Prieska om 16h30 gehou word.
U word vriendelik versoek om die aangehegde Registrasievorm te voltooi en aan ons deur te stuur voor of op **Dinsdag 19 Mei 2015**.

Vriendelike groete

Kind Regards

Andrea Gibb (B.Sc. Landscape Architecture; B.Sc.(Hons) Environmental Management)
Environmental Practitioner and Visual Specialist
SiVEST Environmental Division



SiVEST is a Level 3 BBBEE Contributor

Direct +27 11 798 0638 **Tel** +27 11 798 0600 **fax** +27 11 803 7272 **cell** +27 72 587 6525
email andreag@sivest.co.za **website** www.sivest.co.za

Consulting Engineers - Project Managers - Environmental Consultants - Town and Regional Planners
Durban - Johannesburg - Pietermaritzburg - Richards Bay - Ladysmith - Cape Town - Harare (Zimbabwe)

Disclaimer

The information contained in this communication from the sender is confidential. It is intended solely for use by the recipient and others authorized to receive it. If you are not the recipient, you are hereby notified that any disclosure, copying, distribution or taking action in relation of the contents of this information is strictly prohibited and may be unlawful.

This email has been scanned for viruses and malware, and automatically archived by **Mimecast SA (Pty) Ltd**, an innovator in Software as a Service (SaaS) for business. **Mimecast Unified Email Management ??? (UEM)** offers email continuity, security, archiving and compliance with all current legislation. To find out more, [contact Mimecast](#).



the denc

Department:
Environment & Nature Conservation
NORTHERN CAPE PROVINCE
REPUBLIC OF SOUTH AFRICA

Private Bag X6102, Kimberley, 8300, Metlife Towers, T-Floor, Tel: 053 807 7300, Fax: 053 807 7328

Enquiries :
Dipatlisilo :
Navrae : I. Gwija
Imibuzo :

Date :
Letha :
Datum: 10th June 2015
Umhla :

Reference :
Tshupelo : NC/NAT/PIX/SIY/COPI/2015
Verwysing : 14/12/16/3/3/2/765
Isalathiso : 14/12/16/3/3/2/766
14/12/16/3/3/2/767

SiVEST
51 Wessel Road
Rivonia
2128

Fax: info@sivest.co.za

PROPOSED CONSTRUCTION OF THE HELENA 1, 2 AND 3 75 MW SOLAR PHOTOVOLTAIC (PV) ENERGY FACILITIES NEAR COPPERTON, NORTHERN CAPE PROVINCE DRAFT SCOPING REPORT.

The Department confirms having received the **Draft scoping report** for environmental authorisation of the above mentioned project on the **08th June 2015**. As required in terms of the Environmental Impact Assessment Regulations, 2014.

The application has been assigned the reference number **NC/NAT/PIX/SIY/COP1/2015**. Kindly quote this reference number in any future correspondence in respect of the application. Please note the responsible officer is going to be **Mr. I. Gwija** and can be contacted at **(053) 807 7430/ 7468**.

Yours faithfully











Ms. L. Tools-Bernado
EIA: Administrator

Land Use Classification

-  Degraded Land
-  Mines/Quarries
-  Urban/Built-Up Areas
-  Natural/Undeveloped Areas
-  Waterbodies

PROPOSED CONSTRUCTION OF A 75MW SOLAR PHOTOVOLTAIC (PV) ENERGY FACILITY
HELENA SOLAR 1 NEAR COPPERTON NORTHERN CAPE PROVINCE
BROAD LAND USE CLASSIFICATION

Legend

-  Main Roads
-  Railway Line
-  Existing High Voltage Power Lines (400kV)
-  Main Rivers/Water Courses
-  Existing Substation
-  Application Site
-  Proposed Helena Solar 1 Development Area
-  Substation Assessment Area
-  Proposed Power Line Corridor: Option 1
-  Proposed Power Line Corridor: Option 2

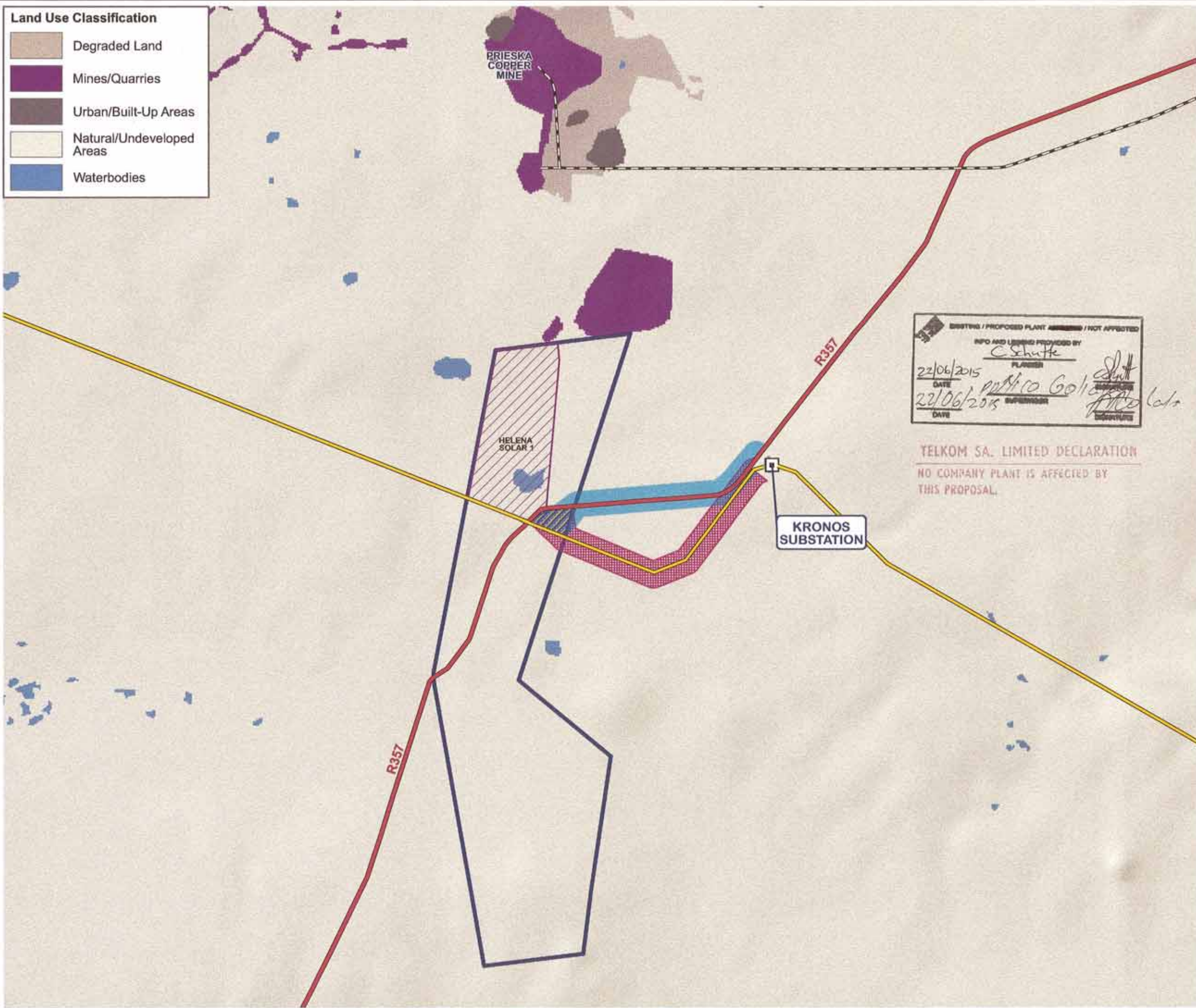

EXISTING / PROPOSED PLANT AFFECTED / NOT AFFECTED
 INFO AND LEGEND PROVIDED BY
 C. Schutte
 PLANNER
 DATE 22/06/2015
 DATE 22/06/2015
 SUPERVISOR
 SUPERVISOR

TELKOM SA. LIMITED DECLARATION
 NO COMPANY PLANT IS AFFECTED BY THIS PROPOSAL.

KRONOS SUBSTATION

SOURCE:
 ESKOM HOLDINGS, 2012
 NGI, 2014
 SANBI, 2009

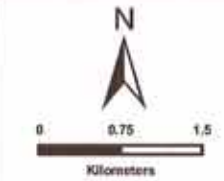

SIVEST
 ENVIRONMENTAL DIVISION
 51 WESSELS ROAD
 RIVONIA, 2128
 JOHANNESBURG
 SOUTH AFRICA
 Phone: +27 11 798 0600
 Fax: +27 11 803 7272
 e-mail: info@sivest.co.za

Project No	Map Ref No	Prepared By	Date
13031	13031/SC1_06	KLS	22/05/2015

"COPYRIGHT IS VESTED IN SIVEST IN TERMS OF THE COPYRIGHT ACT (ACT 96 OF 1978) AND NO USE OR REPRODUCTION OR DUPLICATION THEREOF MAY OCCUR WITHOUT THE WRITTEN CONSENT OF THE AUTHOR"

THIS MAP HAS BEEN PREPARED UNDER THE CONTROLS ESTABLISHED BY THE SIVEST QUALITY MANAGEMENT SYSTEM AND MEETS THE REQUIREMENTS OF THE SETA QUALITY GRADING SYSTEM THAT IS ISO COMPLIANT



Mvelaphande Trading

**WAYLEAVE MANAGEMENT
CENTRAL REGION**

**Mvelaphande Trading
44 B Mill Street
BLOEMFONTEIN
9300**

Enquiries: Chris Schutte
Telephone: 051 - 401 6701/ 0810455686
Fax : 088 0514016238
e-mail : Schutce5@telkom.co.za

Our reference: CCPN0376-15

Your reference: HELENA SOLAR 1 & 2 & 3

22 June 2015

SIVEST
P.O. Box 2921
RIVONIA
2128

EIA COMMENCING FOR THREE 75MW SOLAR PV ENERGY FACILITIES NEAR COPPERTON

With reference to your letter received on 09 June 2015.

With reference to your above-mentioned application, I hereby inform you that our Client (Telkom SA SOC Ltd) approves the proposed work indicated on your drawings in terms of Section 23 of the Electronic Communication Act No. 36 of 2005 as amended.

No infrastructure of our Client (Telkom SA SOC Ltd) will be affected by this proposal.

Although we are not affected by this proposal, Mr Petrus Fourie must be contacted at 081 363 5213 from our Client (Telkom SA SOC Ltd)'s Network Field Services before commencement of work.

Approval of the proposed route is valid for six months. If construction has not yet commenced within this period, then the file must be resubmitted for approval

Any changes/deviations from the original planning during or prior to construction must immediately be communicated to this office.

As per supplied sketches it would appear as if our Client (Telkom SA SOC Ltd)'s infrastructure would not be affected. However, care should still be taken should it become evident that there is in fact our Client (Telkom SA SOC Ltd)'s network present at the actual sites. Such lines should be treated in accordance with, and clearances stipulated in the occupational Health and Safety Act no. 85 of 1993, Electrical Machinery regulations 20 – Crossings, and Electrical Machinery Regulations 15 – Clearance Power Lines. If the specifications could not be met, all deviations costs will be for applicant's account. We also refer to section 25 of the Electronic Communication Act 36 of 2005

Application approved on condition that, should it later be found necessary to deviate the existing communication line due to existing noise interference or any other reason whatsoever, the cost of such remedial action shall be repayable.

On completion of this project, please certify that all requirements as stipulated in this letter have been met. Please note that should any of our Client (Telkom SA SOC Ltd)'s infrastructure has to be relocated or altered as a result of your activities the cost for such alteration or relocation will be for your account in terms of section 25 of the Electronic Communication Act.

Although we are not affected by this proposal, Mr Petrus Fourie must be contacted at 081 363 5213 from our Client (Telkom SA SOC Ltd)'s Network Field Services before commencement of work.

Please notify this office and forward an as built plan, within 30 days of completion of construction.

Should our Client (Telkom SA SOC Ltd)'s infrastructure be damaged while work is undertaken, kindly call the Toll free number – **0800203957** – immediately.

Yours faithfully



Chris Schutte

Hlengiwe Ntuli

From: Natalie Uys <nuys.denc@gmail.com>
Sent: 18 August 2015 09:36 AM
To: Hlengiwe Ntuli
Subject: Re: Helena Solar 1, 2 & 3 Final Scoping Reports Submitted to the DEA

Dear Hlengiwe

Is it possible for you to please send me a dropbox file for the 3 facilities info to make it easier to access and download over the slow connection?

Best regards

Natalie

Best regards

Natalie Uys

Candidate Scientist: Botanist on Contract

Northern Cape Department of Environment and Nature Conservation (DENC), Private Bag X6102, Kimberley, 8300. Tel: 053 - 807 7430/72/81 Fax: 053 - 831 3530 Cell nr. (3G): 0716047621 (can only receive calls), Email: nuys.denc@gmail.com
Website: <http://denc.ncpg.gov.za/> Permit office contact information: Email: dencpermits@ncpg.gov.za (2MB) (For submitting new applications); Tel: 053-8077510/7477; Fax: 086 5151 769 (For submitting new applications) Courier address: 90 Long Street / Longstraat 90, Kimberley. Forms: <http://denc.ncpg.gov.za/index.php/44-about-us/our-services-to-you/117-permit-applications>;

On 18 August 2015 at 09:23, Hlengiwe Ntuli <HlengiweN@sivest.co.za> wrote:

******* Please note that this email was sent from a NO REPLY email address. Please do not reply to this address as it is an unmonitored email account.*******

Dear Interested and/or Affected Party

ENVIRONMENTAL IMPACT ASSESSMENT (EIA) AND ENVIRONMENTAL MANAGEMENT PROGRAMME (EMPr) FOR THE THREE HELENA SOLAR PHOTOVOLTAIC (PV) ENERGY FACILITIES NEAR COPPERTON, NORTHERN CAPE PROVINCE

DEA Ref. HELENA SOLAR 1: 14/12/16/3/3/2/765

HELENA SOLAR 2: 14/12/16/3/3/2/766

HELENA SOLAR 3: 14/12/16/3/3/2/767

- **FSR AVAILABLE FOR REVIEW**

We wish to express our appreciation to the stakeholders who submitted comments on the Draft Scoping Reports (DSRs) for the above mentioned proposed projects during the public review period (Thursday 28 May 2015 to Monday 29 June 2015). After the public review period, the DSRs were updated, taking into consideration the issues and concerns raised by stakeholders.

The Final Scoping Reports (FSRs) were submitted to the Department of Environmental Affairs (DEA) for their consideration on Monday 17 August 2015.

In accordance with the National Environmental Management Act (NEMA), the FSRs will be available for public comment and review from **Tuesday 18 August 2015 to Monday 7 September 2015** (end of business day). The FSRs are available on SiVEST's website: <http://www.sivest.co.za/> click on 'Downloads' (top right), then scroll down to *13031 Helena PV EIA*. Alternatively, please contact SiVEST to obtain an electronic copy of the reports on CD.

Should you have any comments on the FSRs, please submit these in writing directly to the DEA on or before **Monday 7 September 2015** (close of business day):

Department of Environmental Affairs (DEA)

Ms Mmatlala Rabothata

Private Bag X447

PRETORIA

0001

Tel: 012 399 9372

Email: mrabothata@environment.gov.za

As per the EIA Regulations, please send a copy of your comments to the SiVEST Office at the following address:

SiVEST Environmental

Andrea Gibb

PO BOX 2921

Rivonia

2128

Tel: 011 798 0600

Fax: 011 803 7272

Email: andreag@sivest.co.za

Kind Regards,

Andrea Gibb

Environmental Practitioner

SiVEST Environmental Division

SiVEST is a Level 3 BBBEE Contributor

Direct [+27 11 798 0638](tel:+27117980638) **Tel** [+27 11 798 0600](tel:+27117980600) **fax** [+27 11 803 7272](tel:+27118037272)

email AndreaG@sivest.co.za **website** www.sivest.co.za

Consulting Engineers - Project Managers - Environmental Consultants - Town and Regional Planners

Durban - Johannesburg - Pietermaritzburg - Richards Bay - Ladysmith - Cape Town - Harare (Zimbabwe)

Disclaimer

The information contained in this communication from the sender is confidential. It is intended solely for use by the recipient and others authorized to receive it. If you are not the recipient, you are hereby notified that any disclosure, copying, distribution or taking action in relation of the contents of this information is strictly prohibited and may be unlawful.

This email has been scanned for viruses and malware, and automatically archived by **Mimecast SA (Pty) Ltd**, an innovator in

Software as a Service (SaaS) for business. **Mimecast Unified Email Management ??? (UEM)** offers email continuity, security, archiving and compliance with all current legislation. To find out more, [contact Mimecast](#).



Interim Comment

In terms of Section 38 of the National Heritage Resources Act (Act 25 of 1999)

Attention: Sivest - Gauteng
PO BOX 2921
Rivonia
2128

Proposed Construction of the Helena 1, 2, and 3 75MW Solar Photovoltaic (PV) Energy Facilities near Copperton, Northern Cape Province.

Fourie, W. March 2015. THREE 75MW SOLAR PHOTOVOLTAIC (PV) ENERGY FACILITIES – HELENA PROJECTS: Heritage Scoping Report

The proposed development entails three 75mw solar photovoltaic energy facilities and associated infrastructure, near Copperton, Northern Cape Province

The report has demonstrated that the proposed Helena Solar projects may have heritage resources present on the property, as confirmed through archival research and evaluation of aerial photography of the sites. The author recommends further field truthing through an archaeological walk down and palaeontological desktop study covering the site, in order to compile a comprehensive database of heritage sites in the study areas, with the aim of developing a heritage management plan for inclusion in the Environmental Management Plan as derived from the EIA.

Interim Comment

The SAHRA Archaeology, Palaeontology and Meteorites (APM) Unit supports the author's recommendations for an archaeological walk down and palaeontological desktop study covering the site. Once these reports have been submitted, SAHRA APM will be able to provide final comments.

Should you have any further queries, please contact the designated official using the case number quoted above in the case header.

Yours faithfully

Andrew Salomon
Heritage Officer: Archaeology
South African Heritage Resources Agency



ADMIN:

Direct URL to case: <http://www.sahra.org.za/node/273471>
(DEA, Ref: 14/12/16/3/3/2/765, 14/12/16/3/3/2/766, and 14/12/16/3/3/2/767)

Terms & Conditions:

1. This approval does not exonerate the applicant from obtaining local authority approval or any other necessary approval for proposed work.
2. If any heritage resources, including graves or human remains, are encountered they must be reported to SAHRA immediately.
3. SAHRA reserves the right to request additional information as required.



Andrea Gibb

To: Hlengiwe Ntuli; Lynsey Rimbault
Subject: RE: Helena 1, 2 and 3 Solar PV Facilities: EIA Newsletter

From: HettieB [<mailto:HettieB@daff.gov.za>]
Sent: 02 December 2015 11:16 AM
To: Hlengiwe Ntuli <HlengiweN@sivest.co.za>
Subject: RE: Helena 1, 2 and 3 Solar PV Facilities: EIA Newsletter

Good day
Please send me the title deed on this property.

Regards
Hettie Buys

From: Hlengiwe Ntuli [<mailto:HlengiweN@sivest.co.za>]
Sent: 30 November 2015 02:52 PM
Cc: Andrea Gibb; Lynsey Rimbault
Subject: Helena 1, 2 and 3 Solar PV Facilities: EIA Newsletter

***** Please note that this email was sent from a NO REPLY email address. Please do not reply to this address as it is an unmonitored email account. *****

Dear Stakeholder

We would like to take this opportunity to inform you that the Department of Environmental Affairs has accepted the Final Scoping Reports and approved the Plan of Study for the Environmental Impact Phase of the Helena 1, 2, and 3 Solar Photovoltaic Energy Facilities.

Attached is the EIA Newsletter, Comment form and Site Locality Map for your information.

Kind Regards

Andrea Gibb (B.Sc. Landscape Architecture; B.Sc.(Hons) Environmental Management) Environmental Practitioner and Visual Specialist SiVEST Environmental Division

SiVEST is a Level 3 BBBEE Contributor

Direct +27 11 798 0638 Tel +27 11 798 0600 fax +27 11 803 7272
email andreag@sivest.co.za website www.sivest.co.za

Consulting Engineers - Project Managers - Environmental Consultants - Town and Regional Planners
Durban - Johannesburg - Pietermaritzburg - Richards Bay - Ladysmith - Cape Town - Harare (Zimbabwe)

Disclaimer

The information contained in this communication from the sender is confidential. It is intended solely for use by the recipient and others authorized to receive it. If you are not the recipient, you are hereby notified that any disclosure, copying, distribution or taking action in relation of the contents of this information is strictly prohibited and may be unlawful.

This email has been scanned for viruses and malware, and automatically archived by **Mimecast SA (Pty) Ltd**, an innovator in Software as a Service (SaaS) for business. **Mimecast Unified Email Management ??? (UEM)** offers email continuity, security, archiving and compliance with all current legislation. To find out more, [contact Mimecast](#).



agriculture, forestry & fisheries

Department:
Agriculture, forestry & fisheries
REPUBLIC OF SOUTH AFRICA

Directorate Land Use and Soil Management, Private Bag x120, Gezina Pretoria, 0031
Delpen Building, c/o Annie Botha & Union Streets, Riviera

From: Director: Land Use and Soil Management

Tel: (012) 319 7634 **Fax:** (012) 329 5938 **e-mail:** nhlakad@daff.gov.za

**Sivest
PO Box 2921
Rivonia
2128**

8 December 2015

Dear Si/Madam

This serves as a notice of receipt and confirms that your application has been captured in our electronic AgriLand tracking and management system. It is strongly recommended that you use the on-line AgriLand application facility in future.

Detail of your application as captured:

Application type: Solar

Your reference: **Helena Solar 1,2,3**

Property Description: ***Klipgats Pan 117, ptn 3***

Dated: **30 November 2015**

Please use the following reference number in all enquiries:

AgriLand reference number: 2015_12_0073

Enquiries can be made to the above postal, fax or e-mail address.

Yours sincerely,

**HJ Buys
pp DIRECTOR: LAND USE AND SOIL MANAGEMENT**

<http://www.agis.agric.za/agriland>

Andrea Gibb

From: Lehlohonolo Roestof (LB) <RoestLB5@telkom.co.za>
Sent: Tuesday, December 08, 2015 8:34 AM
To: Andrea Gibb
Subject: CCPN0773-15 HELENA SOLAR

Good Day,

We acknowledge receipt of your application for Helena Solar. Our reference is CCPN0773-15 for further enquiries in this regard.

Kind Regards

Ben Roestof
Mvelaphanda Trading
Roestlb5@telkom.co.za
051 401 6256/081 438 3017

~~~~~  
This e-mail is subject to the Telkom SA SOC Ltd electronic communication legal notice,  
available at : <http://www.telkom.co.za/TelkomEMailLegalNotice.PDF>  
~~~~~

Andrea Gibb

From: Hlengiwe Ntuli
Sent: Monday, December 14, 2015 11:29 AM
To: Andrea Gibb; Lynsey Rimbault
Subject: FW: Three Proposed Helena Solar Photovoltaic Energy Facilities: DEIAr Available for Comment
Attachments: Solar Park footprint corners.xls; Pylon Geographic co ordinates.xls

FYA

Kind Regards,

Hlengiwe Ntuli
Projects Secretary
SiVEST Environmental Division



SiVEST is a Level 3 BBBEE Contributor

Direct +27 11 798 0690 **Tel** +27 11 798 0600 **fax** +27 11 803 7272
email HlengiweN@sivest.co.za **website** www.sivest.co.za



Consulting Engineers - Project Managers - Environmental Consultants - Town and Regional Planners
Durban - Johannesburg - Pietermaritzburg - Richards Bay - Ladysmith - Cape Town - Harare (Zimbabwe)

From: Lizelle Stroh [mailto:StrohL@caa.co.za]
Sent: 14 December 2015 11:26 AM
To: Hlengiwe Ntuli <HlengiweN@sivest.co.za>
Subject: RE: Three Proposed Helena Solar Photovoltaic Energy Facilities: DEIAr Available for Comment

Your enquiry regarding approval from the SACAA with regard to PV farms refers. There is a SACAA process whereby permission is applied for wrt obstacles which could pose an aviation hazard. More information can be obtained at <http://www.caa.co.za>. Click on information for industry 'Obstacles' on the LHS. Forms, Part 139-27 and submit on the form itself.

- Kindly provide a **.kml (Google Earth) file reflecting the footprint of the proposed development site including the proposed overhead electric power line route that will evacuate the generated power to the national grid.**
- Also indicate the **highest** structure of the project & the Overhead electric power transmission line.
- Note that there may be other wind farms and PV farms in the area. Unique names are preferable.
- *Please always use the proposed PV farm name in the Subject box when corresponding via email with this office and indicate the name & address which should appear on the CAA approval/decline letter.*
- *There is an assessment fee of R690 per application.*
- *For billing purposes: company name VAT nr. and postal details.*

- *Kindly ensure that all the above data is forwarded. Incomplete data causes unnecessary delays.*

Note that the lead time for approval may take up to 90 days upon receipt of the correct data.

Thanks

Kind regards



Lizell Stroh
Obstacle Specialist
PANS-OPS (Procedures for Air navigation Services – Aircraft Operations)
Air Navigation Services
Tel: +27 11 545 1232 | Fax: +27 011 545 1282 | Mobile: +27 83 461 6660 |
Email: strohl@caa.co.za
www.caa.co.za
Follow us on  

From: Hlengiwe Ntuli [<mailto:HlengiweN@sivest.co.za>]

Sent: 14 December 2015 11:04 AM

To: Andrea Gibb; Lynsey Rimbault

Cc: 'Sindisile Madyo'; 'John Geeringh'; Lizelle Stroh; 'Simon Gear'; 'Amanda Bester'; 'Andrew Timothy'; 'Lourens Leeuwner'; 'Thulani Mthombeni'; 'Heleen van den Heever'; 'Thoko Buthelezi'; 'Simphiwe Masilela'; 'Onwabile Ndzumo'; 'JRM Alexander'; 'Mashudu Marubini'; 'Ester Makungo'; 'Johan Koegelenberg'; 'Johanna Morobane'; 'Jenna Lavin'; 'Jasper Nieuwoudt'; 'Jacoline Mans'; 'Ivan Steenkamp'; 'Suzanne Erasmus'; 'Gert Steenkamp'; 'Sam Fiff'; 'Shaun Dyers'; 'Adriaan Tiplady'

Subject: Three Proposed Helena Solar Photovoltaic Energy Facilities: DEIAr Available for Comment

***** Please note that this email was sent from a NO REPLY email address. Please do not reply to this address as it is an unmonitored email account. *****

Dear Stakeholder

ENVIRONMENTAL IMPACT ASSESSMENT (EIA) FOR THE PROPOSED CONSTRUCTION OF THREE HELENA 75MW SOLAR PHOTOVOLTAIC (PV) ENERGY FACILITIES NEAR COPPERTON, NORTHERN CAPE PROVINCE

* DEA Ref No: HELENA SOLAR 1: 14/12/16/3/3/2/765

HELENA SOLAR 2: 14/12/16/3/3/2/766

HELENA SOLAR 3: 14/12/16/3/3/2/767

As indicated in the email which was sent you on Wednesday 9 December 2015, we would like to remind you that in accordance with the National Environmental Management Act (NEMA), the three Draft Environmental Impact Assessment Reports (DEIARs) have been made available for public comment and review as from Wednesday 9 December 2015 to Wednesday 27 January 2016 (end of business day).

For your convenience, electronic copies (on CD) of the three DEIARs as well as the accompanying appendices have been posted to you. The reports are also available on SiVEST's website: <http://www.sivest.co.za/>, click on 'Downloads' and then browse to the folder '13031 Helena PV EIA'. We kindly request that you submit your comments to us at the below details, on or before Wednesday 27 January 2016 (end of business day). In terms of section 56 (7) of the Environmental Impact Assessment Regulations 2010, under Government Notices No R543, comments from state departments will be accepted until Monday 8 February 2016 (end of business day). SiVEST will forward any comments received after the public comment and review period directly to the relevant case officer at the Department of Environmental

Affairs (DEA).

Should you have any questions or queries please do not hesitate to contact us at:

Andrea Gibb / Lynsey Rimbault
PO BOX 2921, Rivonia, 2128
Tel - (011) 798 0600
Fax - (011) 803 7272
Email - andreag@sivest.co.za / lynseyr@sivest.co.za

Kind Regards

Andrea Gibb (B.Sc. Landscape Architecture; B.Sc.(Hons) Environmental Management) Environmental Practitioner and Visual Specialist
SiVEST Environmental Division

SiVEST is a Level 3 BBBEE Contributor

Direct +27 11 798 0638 Tel +27 11 798 0600 fax +27 11 803 7272
email andreag@sivest.co.za website www.sivest.co.za

Consulting Engineers - Project Managers - Environmental Consultants - Town and Regional Planners
Durban - Johannesburg - Pietermaritzburg - Richards Bay - Ladysmith - Cape Town - Harare (Zimbabwe)

Disclaimer

The information contained in this communication from the sender is confidential. It is intended solely for use by the recipient and others authorized to receive it. If you are not the recipient, you are hereby notified that any disclosure, copying, distribution or taking action in relation of the contents of this information is strictly prohibited and may be unlawful.

This email has been scanned for viruses and malware, and automatically archived by **Mimecast SA (Pty) Ltd**, an innovator in Software as a Service (SaaS) for business. **Mimecast Unified Email Management ??? (UEM)** offers email continuity, security, archiving and compliance with all current legislation. To find out more, [contact Mimecast](#).

Andrea Gibb

From: Lehlohonolo Roestof (LB) <RoestLB5@telkom.co.za>
Sent: Monday, December 14, 2015 11:34 AM
To: Andrea Gibb
Cc: Vivian Groenewald (VR)
Subject: CCPN0773-15 ENVORIMENTAL ASSESSMENT FOR HELENA SOLAR
Attachments: CCPN0773-15 COVER LETTER.pdf; CCPN0773-15 UPDATED SKETCH.pdf

Good day

Approval is granted, subject to the following conditions, as per attached drawings supplied, our Client (Telkom SA SOC Ltd) infrastructure will be affected as indicated in GREEN. Our Client (Telkom SA SOC Ltd) infrastructure must be regarded as approximate only. Consequently, the following conditions apply:

Mr Vivian Groenewald must be contacted at 054 338 6501/081 362 6738 two weeks prior of commencement on construction work.

Regards,

Ben Roestof
Mvelaphanda Trading
Roestlb5@telkom.co.za
051 401 6256/081 438 3017

~~~~~  
This e-mail is subject to the Telkom SA SOC Ltd electronic communication legal notice,  
available at : <http://www.telkom.co.za/TelkomEMailLegalNotice.PDF>  
~~~~~



Mvelaphande Trading

Mvelaphande Trading
44 B Mill Street
BLOEMFONTEIN
9300

Enquiries: Lehlohonolo Roestof
Telephone: 051 - 401 6256/ 0814383017
Fax : 088 0514016238
E-mail : Roestlb5@telkom.co.za

Our reference: CCPN0773-15

Your reference: 13031

14 December 2015

SIVEST
P O Box 2921
RIVONIA
2128

ENVIROMENTAL IMPACT ASSESSMENT (EIA) AND ENVIROMENTAL MANAGEMENT PROGRAMME (EMPr) FOR THE HELENA SOLAR PHOTOVOLTAIC (PV) ENERGY FACILITIES NEAR COPPERTON

With reference to your letter dated 30 November 2015.

With reference to your above-mentioned application, I hereby inform you that our Client (Telkom SA SOC Ltd) approves the proposed work indicated on your drawings in terms Section 29 of the Electronic Communications Act 36 of 2005 as amended.

Any changes/deviations from the original planning during or prior to construction must immediately be communicated to this office.

Approval is granted, subject to the following conditions, as per attached drawings supplied, our Client (Telkom SA SOC Ltd) infrastructure will be affected as indicated in GREEN. Our Client (Telkom SA SOC Ltd) infrastructure must be regarded as approximate only. Consequently, the following conditions apply:

Aerial Plant - At points of crossing, the overhead power lines should cross above the communications lines in accordance with and clearances stipulated in the Occupational Health and safety Act no 85 of 1993, Machinery regulations 20 – Crossings, and Electrical machinery Regulations 15 – Clearance of Power Lines. If the specifications could not be met, all deviation costs will be for the applicant's account. We also refer to section 25 of Electronic Communication Act 36 of 2005.

At points of crossing, the overhead power line should cross over the overhead communication lines with a minimum vertical separation of 0.6 meters.

Suitable protection as laid down in section 5 of the Code of Practice should be provided at all important crossings.

The crossing of supply lines or overhead service mains directly above or adjacent to communication poles must be avoided if possible. If not clearance of 3 meters must be provided.

In order to minimize noise induction into the telecommunication systems, the angle of crossing between the overhead power line and all communication lines, should be as near to a right angle as possible – the following deviation from the right angle being permitted at:

- Power voltage of lower than 48 kV - 45 degrees

Approved on condition that, should it later be found necessary to deviate the existing communication line due to existing noise interference or any other reason whatsoever, the cost of such remedial action shall be repayable.

Paragraph 2.4.1 of the Code of Practice stipulates the minimum acceptable horizontal separation between power and the communication lines and where this cannot be met, the design of the power line is also stipulated. This could apply between the attached plans and these requirements should strictly be adhered to.

Calculations have shown that an earth fault on the high voltage Power lines will induce excessive low frequency induction into the Communication lines. As a result of this, the cost to deviate / alter the communication lines to prevent this induction will be for the power provider.

Approved on condition that, should it later be found necessary to deviate the existing communication line due to existing noise interference or any other reason whatsoever, the cost of such remedial action shall be repayable.

Relocations of our Client (Telkom SA SOC Ltd) plant will be done at customer's request and will be a repayable project.

Please notify the office within 21 working days from date of this letter of acceptance and if any alternative proposal is available of if a recoverable work should commence, the liaison officer is **Lehlohonolo Roestof** at tel. no. **051 – 401 6256**.

As important cables are affected, **Mr Vivian Groenewald must be contacted at 054 338 6501/081 362 6738 two weeks prior of commencement on construction work. It would be appreciated if this office can be notified within 30 days on completion of construction work.** Confirmation is required on completion of construction as per agreed requirements.

On completion of this project please certify that all requirements as stipulated in this letter have been met. Please note that should any of our Client (Telkom SA SOC Ltd) infrastructure has to be relocated or altered as a result of your activities the cost for such alterations or relocations will be for your account in terms of section 25 of the Electronic Communications Act.

Should our Client (Telkom SA SOC Ltd) infrastructure be damaged while work is undertaken, kindly call the Toll free number **0800203951** immediately

All of our Client (Telkom SA SOC Ltd) rights remain reserved.



Mr Vivian Groenewald must be contacted at 054 338 6501/081 362 6738, before any commencement of work.

Yours faithfully



L Roestof

Development Areas









-  Helena Solar 1
-  Helena Solar 2
-  Helena Solar 3

**PROPOSED
CONSTRUCTION OF
THREE 75MW SOLAR
PHOTOVOLTAIC (PV)
ENERGY FACILITIES**

**HELENA SOLAR 1; HELENA
SOLAR 2 AND HELENA SOLAR 3
NEAR COPPERTON
NORTHERN CAPE PROVINCE**

SITE LOCALITY

Legend



-  Main Roads
-  Railway Line
-  Existing High Voltage Power Lines (400kV)
-  Existing Substations
-  Adjoining Farm Boundaries
-  Application Site
-  Substation Assessment Area
-  Proposed Power Line Corridor: Option 1 (500m)
-  Proposed Power Line Corridor: Option 2 (500m)

TELKOM SA SOC LTD LEGEND

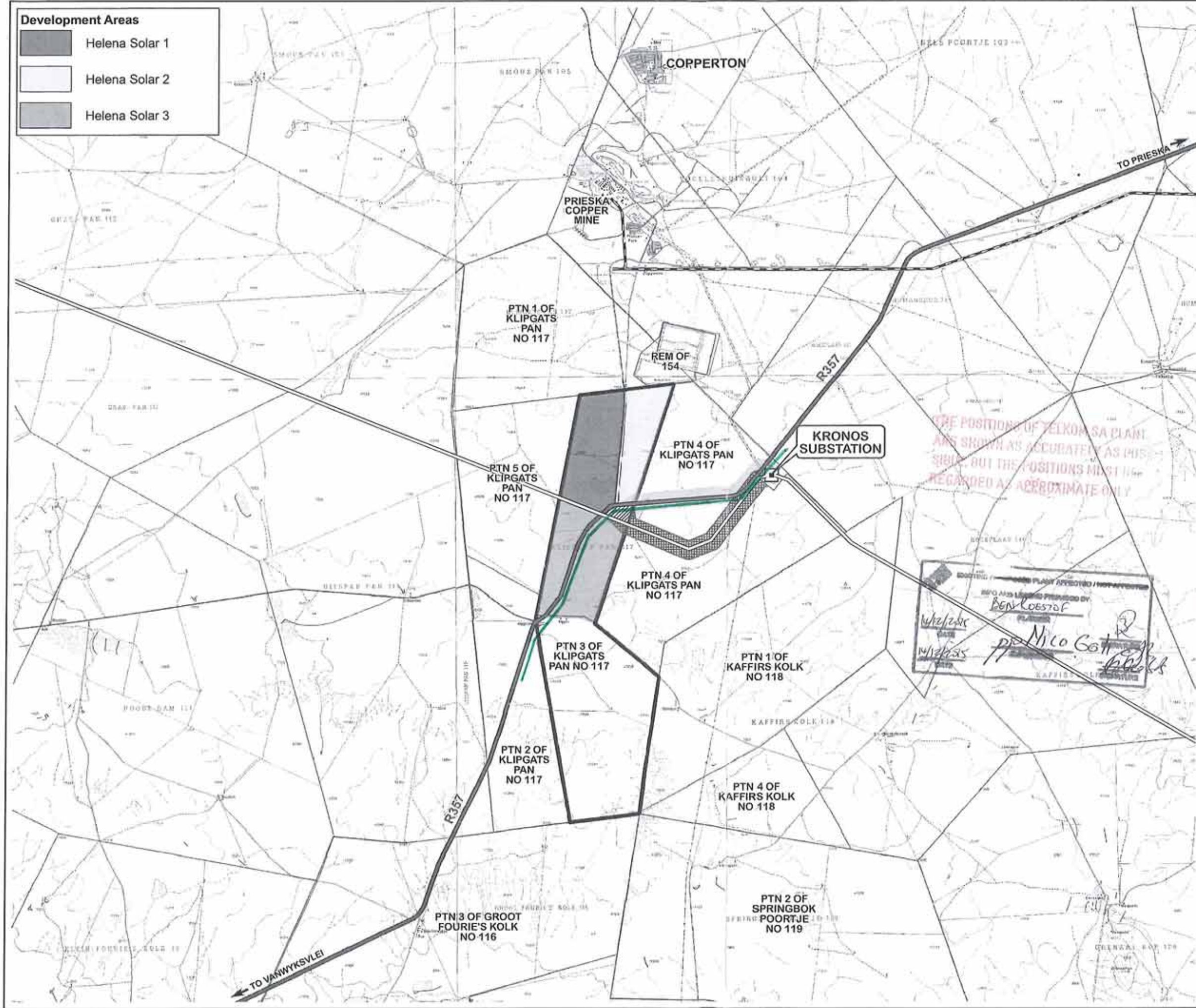
 OVERHEAD CABLE



SOURCE:
ESKOM HOLDINGS, 2012
MUNICIPAL DEMARICATION BOARD, 2011



 Kilometers

SIVEST

ENVIRONMENTAL DIVISION
51 WESSELS ROAD
RIVONIA, 2128
JOHANNESBURG
SOUTH AFRICA

Phone: +27 11 780 0600
Fax: +27 11 903 7272
e-mail: info@sivest.co.za

Project No	Map Ref No	Prepared By	Date
13031	13031/SC1_01	KLS	24/02/2015

"COPYRIGHT IS VESTED IN SIVEST IN TERMS OF THE COPYRIGHT ACT (ACT 98 OF 1978) AND NO USE OR REPRODUCTION OR DUPLICATION THEREOF MAY OCCUR WITHOUT THE WRITTEN CONSENT OF THE AUTHOR"

THIS MAP HAS BEEN PREPARED UNDER THE CONTROLS ESTABLISHED BY THE SIVEST QUALITY MANAGEMENT SYSTEM AND MEETS THE REQUIREMENTS OF THE SETA QUALITY GRADING SYSTEM THAT IS ISO COMPLIANT



17 Baker Street
Rosebank
Johannesburg
South Africa
2196

Tel: +27 (0) 11 442 2434
Fax: +27 (0) 11 442 2454
Email: atiplady@ska.ac.za

Andrea Gibb
Environmental Practitioner and Visual Specialist
SiVEST Environmental Division
PO Box 2921
Rivonia
2128

E-mail: andrea@sivest.co.za

Date: 17 December 2015

Dear Andrea,

**Re: Development of three 75MW Solar PV Energy Facilities (Helena Solar 1-3) near
Copperton in the Northern Cape Province.**

A high level risk assessment was conducted for the above mentioned photovoltaic electricity generation facilities, based on the distance to the nearest SKA station and information available on the detailed design of PV facilities. The result of the initial assessment, which indicated that the proposed facility could pose a medium to high risk of detrimental impact on the SKA telescope, was communicated to SiVest Environmental Division in a letter dated 23 February 2015. In the letter, it was recommended that further detailed electromagnetic interference (EMI) studies be conducted in order to scientifically validate the impact of the proposed PV facilities on the SKA, and also to identify any possible mitigation measures that could result in the facility meeting SKA radio emission protection requirements.

Since February, SKA South Africa has engaged with the developers, BioTherm Energy, on this and other projects. BioTherm appointed MESA Solutions (Pty) Ltd to conduct appropriate EMI studies. The initial results from the topographical technical report produced by MESA Solutions (Pty) Ltd, based on radio propagation simulations, were found to be inconclusive. SKA South Africa requested more detailed studies to be conducted, which would have to include measuring the electromagnetic profile of facilities that use similar technology as the one proposed for Helena PV facilities. These measurements have been conducted, and a report provided to SKA South Africa for review.

The results from both studies conducted by MESA Solutions indicates that the development of these facilities would pose a high risk of detrimental impact on the SKA radio telescope – higher than originally understood. This risk is even higher once consideration is given to the cumulative impact of multiple facilities at, or near, the proposed location. The proposed mitigation measures are untested at the scale of implementation required, and



technical proof of concepts would need to be implemented and measured to prove their efficacy before the identified risk is to be revisited.

If these facilities were to be developed as currently defined, they would pose an unacceptable risk to the SKA, and would not be able to meet SKA radio emission protection requirements as prescribed in the Astronomy Geographic Advantage Act. SKA South Africa therefore does not support the development of these projects as they are currently defined, or until further proof of concepts tests can be conducted to assess the efficacy of proposed mitigation measures, whereupon SKA South Africa will review the risk (review of this risk does not guarantee the risk can be reduced to an acceptable level).

This technical advice is provided by the South African SKA Project Office on the basis of the protection requirements of the SKA in South Africa, and does not constitute legal approval of the renewable energy projects in terms of the Astronomy Geographic Advantage Act, the Management Authority, and its regulations or declarations.

Regards,

Dr. Adrian Tiplady
Head of Strategy
SKA South Africa
Tel: 011 442 2434
Fax: 011 442 2454
atiplady@ska.ac.za



the denc

Department:
Environment & Nature Conservation
NORTHERN CAPE PROVINCE
REPUBLIC OF SOUTH AFRICA

Private Bag X6102, Kimberley, 8300, Metlife Towers, T-Floor, Tel: 053 807 7300, Fax: 053 807 7328

Enquiries :
Dipatlisiso : I. Gwija
Navrae :
Imibuzo :

Date :
Letlha : 19th January 2016
Datum:
Umhla :

Reference :
Tshupelo : NC/NAT/PIX/SIY/COP1/2015
Verwysing : 14/12/16/3/3/2/765
Isalathiso : 14/12/16/3/3/2/766
14/12/16/3/3/2/767

SiVEST
51 Wessel Road
Rivonia
2128

Fax: info@sivest.co.za

ENVIRONMENTAL IMPACT ASSESSMENT (EIA) FOR THE PROPOSED CONSTRUCTION OF THREE HELENA 75MW SOLAR PHOTOVOLTAIC (PV) ENERGY NEAR COPPERTON, NORTHERN CAPE PROVINCE.

The Department confirms having received the **EIA and X 1 CD** for environmental authorisation of the above mentioned project on the **14th January 2016**. As required in terms of the Environmental Impact Assessment Regulations, 2014.

The application has been assigned the reference number **NC/NAT/PIX/SIY/COP1/2015**. Kindly quote this reference number in any future correspondence in respect of the application. Please note the responsible officer is going to be **Mr Isaac Gwija** and can be contacted at **(053) 631 0601/16**.

Yours faithfully

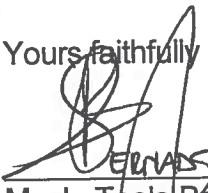

Ms. L. Tools-Bernado
EIA: Administrator



BirdLife South Africa is a partner of BirdLife International, a global partnership of nature conservation organisations.
Member of IUCN (International Union for Conservation of Nature).
Reg No: 001 – 298 NPO
PBO Exemption No: 930004518

Andrea Gibb
SiVEST Environmental Division
andrea@sivest.co.za

1 February 2016

Dear Andrea

Re: Proposed Construction of the three Helena 75MW solar photovoltaic (PV) energy facilities near Copperton, Northern Cape Province

DEA ref no: Helena solar 1: 14/12/16/3/3/2/765
Helena solar 2: 14/12/16/3/3/2/766
Helena solar 3: 14/12/16/3/3/2/767

BirdLife South Africa would like to thank you for the opportunity to comment on the above reports. We are pleased that an avifaunal specialist study has been conducted. As noted in the avifaunal specialist's report BirdLife South Africa's guidelines on solar energy (2012) are undergoing substantial update. The guidelines should be finalised soon and we encourage environmental assessment practitioners to familiarise themselves with the updated version and use these to guide the scope impact assessments in the future.

Seasonal variation can have a significant impact on the presence, absence or movement of bird species. Our updated guidelines therefore recommend that avifaunal studies for proposed developments such as Helena 1, 2 and 3 should include surveys over a period of at least 6 months, preferably spanning the wet and dry season. However, the updated guidelines have not been finalised, and given the homogenous nature of the receiving environment, and that surveys have been conducted for other proposed developments nearby, we are satisfied with the specialist's approach.

The proximity of the proposed developments to a Martial Eagle nest is a concern. We do not usually support the relocation of nests (preferring the relocation of developments to more suitable areas), but given the large number of developments around the area, and that the birds are already facing disturbance, displacement and effective habitat loss, the provision of an alternative structure for nesting may be a solution. However, nest relocation is invasive and success is not guaranteed. It is therefore important that the relevant authorities are consulted before proceeding. The location of the new nest site will need to be carefully selected to ensure that it is not within an area that has also been earmarked for development.

While we respect the need for security, we discourage the use of double fencing around the solar facility. Birds and other animals may get stuck between the fences causing unintended harm.

Isidell House, 17 Hume Road
Dunkeld West, Gauteng 2196
Private Bag X5000, Parklands
Johannesburg, Gauteng 2121, South Africa
Tel: +27 (0)11 789 1122
Fax: +27 (0)11 789 5185
Email: info@birdlife.org.za
www.birdlife.org.za





BirdLife South Africa is a partner of BirdLife International, a global partnership of nature conservation organisations.
Member of IUCN (International Union for Conservation of Nature).
Reg No: 001 – 298 NPO
PBO Exemption No: 930004518

We support the proposed use of Bird Flight Diverters and we recommend that their installation along the entire length of the new transmission line should be a condition of authorisation, should this be granted.

The EIA reports do not indicate whether evaporation ponds will be constructed. Appropriately designed evaporation pond(s) could provide valuable habitat to birds in this arid environment, although the benefits of this should be carefully weighed against the risk that contaminated water could pose to birds. If evaporation ponds are planned we suggest this issue should be addressed in the impact assessments.

BirdLife South Africa supports the responsible development of renewable energy. When viewed in isolation, we are satisfied that the impacts of the proposed facilities on birds have been adequately identified and addressed. However, the cumulative impact of displacement is a concern, particularly for species such as Martial Eagle, Ludwig's Bustard, Kori Bustard and endemic passerines. We therefore encourage developers/operators of solar facilities in the area to collaborate to ensure environmental impacts are minimised and that conservation gains are realised (e.g. with regards to the relocation and monitoring of the Martial Eagle nest, the management of remaining habitat, and minimising the use of fencing).

Given our limited understanding of the impacts of solar energy on birds we strongly support the proposed operational-phase monitoring of birds. Again, significant gains could be made though collaborating with neighbouring renewable energy facilities in this regard (i.e. resources could be pooled to look at questions most relevant to the fauna in the area).

BirdLife South Africa wishes to facilitate the exchange of information and help improve decision-making in the future; we therefore request that the results of operational-phase monitoring be shared with us and made available to other relevant stakeholders.

Yours sincerely

Simon Gear
Policy & Advocacy Manager

with

Mmatjie Mashao
Birds and Renewable Energy Intern

Isdell House, 17 Hume Road
Dunkeld West, Gauteng 2196
Private Bag X5000, Parklands
Johannesburg, Gauteng 2121, South Africa
Tel: +27 (0)11 789 1122
Fax: +27 (0)11 789 5185
Email: info@birdlife.org.za
www.birdlife.org.za



Partner for
Sustainable Energy



Isdell House, 17 Hume Road
Dunkeld West, Gauteng 2196
Private Bag X5000, Parklands
Johannesburg, Gauteng 2121, South Africa
Tel: +27 (0)11 789 1122
Fax: +27 (0)11 789 5188
Email: info@birdlife.org.za
www.birdlife.org.za



Partnership for
Sustainable Design



Honorary Patrons: Mrs Gaynor Rupert, Dr Precious Moloi-Motsepe, Mr Mark Shuttleworth



agriculture, forestry & fisheries

Department:
Agriculture, Forestry and Fisheries
REPUBLIC OF SOUTH AFRICA

Private Bag X120, Pretoria (Tshwane), 0001
Delpen Building, C/o Annie Botha & Union Street, Riviera, 0084

From: Directorate Land Use and Soil Management
Tel: 012-319-7634 Fax: 012-329-5938 E-mail: Thokob@nda.agric.za
Enquiries: Helpdesk Ref: 2015_12_0073

Sivest Environmental
P. O. Box 2921
RIVONIA
2128

Attention: Andrea Gibb

PROPOSED CONTRUCTION OF THREE HELENA 75MW SOLAR PHOTOVOLTAIC (PV) ENERGY FACILITY ON PORTION 4 AND PORTION 5 OF THE FARM KLIP PAN NO. 117, NORTHERN CAPE PROVINCE

Your letter bearing reference 13031 dated November 2015 refers.

With reference to the above-mentioned matter, the department wishes to inform you that it has no objection against the Solar Energy Facility on the above mentioned property measuring approximately 1266 hectares. However the following needs to be adhered to:

- This approval is granted subject to the proposed project being awarded as a preferred bidder by the Department of Energy.
- Any further extension of this proposed project should be reviewed in terms of the Subdivision of Agricultural Land Act, 70 (Act 70 of 1970).
- No subdivision for the purposes of demarcating the individual footprint area should be allowed.
- No construction should be placed in areas that are of high or unique agricultural value and those that are under cultivation.
- Natural vegetation should be restored after the construction of the plant to prevent degradation.
- Where applicable a provision should be made for the control of runoff water.
- Water needed for the maintenance of the site should not be sourced from existing water rights allocated to the site or nearby farm portions as it will negatively impact on agricultural production.

- The applicant should take responsibility for the maintenance and well being of the natural resources base of the site.
- These comments are valid for two years and if the development does not take place, the proposed rezoned portions must revert back to its original parent portion and remain agricultural land in terms of section (1) of the Subdivision of Agricultural Land Act, Act 70 of 1970.
- The application for the registration of the long-term lease shall be considered upon receipt of the positive Record of Decision and a copy of the rezoning approval.

These comments do not exempt any person from the provisions of any other law, with special reference to the Conservation of Agricultural Resources Act, 1983 (Act 43 of 1983) and does not purport to interfere with the rights of any person who may have an interest in the agricultural land.

Yours faithfully



DR M.E. TAU
DEPUTY DIRECTOR-GENERAL: FORESTRY
AND NATURAL RESOURCES MANAGEMENT
DELEGATE OF THE MINISTER

DATE: 27.07.2016

CC: Coenrad Agenbach, Deputy Director: Environmental Impact Evaluation: Special Projects, Department of Environmental Affairs,
Private Bag X447, PRETORIA, 0001
Fax: 012 320 7539

Andrea Gibb

From: Andrea Gibb
Sent: Wednesday, May 13, 2015 7:58 AM
To: 'René de Kock (WR)'
Subject: RE: Helena PV Energy Facilities near Copperton: Public Meeting Invite
Attachments: A3_13031_SiteLocalityLR.pdf

Hi René

Attached is the site locality map. As indicated on the map, no national roads are located within close proximity to the proposed development.

Kind Regards

Andrea Gibb (B.Sc. Landscape Architecture; B.Sc.(Hons) Environmental Management)
Environmental Practitioner and Visual Specialist
SiVEST Environmental Division



SiVEST is a Level 3 BBBEE Contributor

Direct +27 11 798 0638 **Tel** +27 11 798 0600 **fax** +27 11 803 7272 **cell** +27 72 587 6525
email andrea@sivest.co.za **website** www.sivest.co.za



Consulting Engineers - Project Managers - Environmental Consultants - Town and Regional Planners
Durban - Johannesburg - Pietermaritzburg - Richards Bay - Ladysmith - Cape Town - Harare (Zimbabwe)

From: René de Kock (WR) [mailto:Dekockr@nra.co.za]
Sent: Tuesday, May 12, 2015 3:01 PM
To: Andrea Gibb
Subject: RE: Helena PV Energy Facilities near Copperton: Public Meeting Invite

Andrea,

Thank you for your email.

Please forward me a locality map in relation to the site and the national road. I need to make sure if SANRAL is affected or not.

Kind regards



Ms René de Kock

Statutory Control
Tel: +27 21 957 4607
Fax: +21 946 1630



Are you ready?
Get tagged

Cell:
Email: Dekockr@nra.co.za

Western Region
1 Havenga Street Oakdale Bellville
Private Bag X19
www.nra.co.za
SANRAL Fraud Hotline: 0800204558

From: Andrea Gibb [<mailto:AndreaG@sivest.co.za>]
Sent: 12 May 2015 02:14 PM
Cc: Nicolene Venter (nicolenev@zitholele.co.za); Lynsey Rimbault
Subject: Helena PV Energy Facilities near Copperton: Public Meeting Invite

Dear Stakeholder

Attached herewith is your invitation and draft agenda for the Public Meeting that will be held on **Thursday 21 May 2015** at the Omega Hall, Bonteheuwel, Prieska at 16h30.
Kindly complete the attached Registration Form and return it to us before **Tuesday 19 May 2015**.

Kind Regards

Beste Rolspeler

Aangeheg is u uitnodiging en konsep agenda vir die Publiekevergadering wat op **Donderdag 21 Mei 2015** by Omega Hall, Bonteheuwel, Prieska om 16h30 gehou word.
U word vriendelik versoek om die aangehegde Registrasievorm te voltooi en aan ons deur te stuur voor of op **Dinsdag 19 Mei 2015**.

Vriendelike groete

Kind Regards
Andrea Gibb (*B.Sc. Landscape Architecture; B.Sc.(Hons) Environmental Management*)
Environmental Practitioner and Visual Specialist
SIVEST Environmental Division



SIVEST is a Level 3 BBBEE Contributor

Direct +27 11 798 0638 **Tel** +27 11 798 0600 **fax** +27 11 803 7272 **cell** +27 72 587 6525
email andrea@sivest.co.za **website** www.sivest.co.za



Consulting Engineers - Project Managers - Environmental Consultants - Town and Regional Planners
Durban - Johannesburg - Pietermaritzburg - Richards Bay - Ladysmith - Cape Town - Harare (Zimbabwe)

Disclaimer

The information contained in this communication from the sender is confidential. It is intended solely for use by the recipient and others authorized to receive it. If you are not the recipient, you are hereby notified that any disclosure, copying, distribution or taking action in relation of the contents of this information is strictly prohibited and may be unlawful.

This email has been scanned for viruses and malware, and automatically archived by **Mimecast SA (Pty) Ltd**, an innovator in Software as a Service (SaaS) for business. **Mimecast Unified Email Management ??? (UEM)** offers email continuity, security, archiving and compliance with all current legislation. To find out more, [contact Mimecast](#).

Disclaimer:

This message contains confidential information and is intended only for the individual named.

If you are not the named addressee you should not disseminate, distribute or copy this e-mail.

Please notify the sender immediately by e-mail if you have received this e-mail by mistake and delete this e-mail from your system. E-mail transmission cannot be guaranteed to be secure or without errors as information could be intercepted, corrupted, lost, destroyed, arrive late or incomplete, or contain viruses.

The sender therefore does not accept liability for any errors or omissions in the contents of this message, which arise as a result of e-mail transmission.

If verification is required please request a hard-copy version. The South African National Roads Agency SOC Ltd, PO Box 415, Pretoria, 0001, South Africa, Tel +27-(0)12 844 8000, www.nra.co.za.

This Disclaimer is deemed to form part of the content of this email in terms of Section 11 of the Electronic Communications and Transactions Act, 25 of 2002.

Lynsey Rimbault

From: Lynsey Rimbault
Sent: 27 August 2015 13:32
To: 'nuys.denc@gmail.com'
Cc: Hlengiwe Ntuli
Subject: RE: Helena Solar 1, 2 & 3 Final Scoping Reports Submitted to the DEA

Dear Natalie,

We apologise for the delayed reply. The full three reports (including all appendices) are available on the SiVEST website at : <http://www.sivest.co.za/> click on 'Downloads'. They should be easily available at the same speed as Dropbox. If necessary I can create a Dropbox folder that contains the three FSRs but excluding appendices. Please let me know if this is necessary.

Kind Regards

Lynsey Rimbault (B.Sc.(Hons) Geography; M.Sc. Biodiversity, Conservation and Management)
Environmental Consultant
SiVEST Environmental



SiVEST is a Level 3 BBBEE Contributor

Direct +27 11 798 0631 **Tel** +27 11 798 0600 **fax** +27 11 803 7272 **cell** +27 82 669 9558
email lynseyr@sivest.co.za **website** www.sivest.co.za



Consulting Engineers - Project Managers - Environmental Consultants - Town and Regional Planners
Durban - Johannesburg - Pietermaritzburg - Richards Bay - Ladysmith - Cape Town - Harare (Zimbabwe)

From: Natalie Uys [<mailto:nuys.denc@gmail.com>]
Sent: 18 August 2015 09:36 AM
To: Hlengiwe Ntuli <HlengiweN@sivest.co.za>
Subject: Re: Helena Solar 1, 2 & 3 Final Scoping Reports Submitted to the DEA

Dear Hlengiwe

Is it possible for you to please send me a dropbox file for the 3 facilities info to make it easier to access and download over the slow connection?

Best regards
Natalie

Best regards
Natalie Uys
Candidate Scientist:Botanist on Contract

Northern Cape Department of Environment and Nature Conservation (DENC), Private Bag X6102, Kimberley, 8300. Tel: 053 - 807 7430/72/81 Fax: 053 - 831 3530 Cell nr. (3G): 0716047621 (can only receive calls), Email: nuys.denc@gmail.com
Website: <http://denc.ncpg.gov.za/> Permit office contact information: Email: dencpermits@ncpg.gov.za (2MB) (For submitting new applications); Tel: 053-8077510/7477; Fax: 086 5151 769 (For submitting new applications) Courier address: 90 Long Street / Longstraat 90, Kimberley. Forms: <http://denc.ncpg.gov.za/index.php/44-about-us/our-services-to-you/117-permit-applications>;

On 18 August 2015 at 09:23, Hlengiwe Ntuli <HlengiweN@sivest.co.za> wrote:

******* Please note that this email was sent from a NO REPLY email address. Please do not reply to this address as it is an unmonitored email account.*******

Dear Interested and/or Affected Party

ENVIRONMENTAL IMPACT ASSESSMENT (EIA) AND ENVIRONMENTAL MANAGEMENT PROGRAMME (EMPr) FOR THE THREE HELENA SOLAR PHOTOVOLTAIC (PV) ENERGY FACILITIES NEAR COPPERTON, NORTHERN CAPE PROVINCE

DEA Ref. **HELENA SOLAR 1: 14/12/16/3/3/2/765**

HELENA SOLAR 2: 14/12/16/3/3/2/766

HELENA SOLAR 3: 14/12/16/3/3/2/767

• **FSR AVAILABLE FOR REVIEW**

We wish to express our appreciation to the stakeholders who submitted comments on the Draft Scoping Reports (DSRs) for the above mentioned proposed projects during the public review period (Thursday 28 May 2015 to Monday 29 June 2015). After the public review period, the DSRs were updated, taking into consideration the issues and concerns raised by stakeholders.

The Final Scoping Reports (FSRs) were submitted to the Department of Environmental Affairs (DEA) for their consideration on Monday 17 August 2015.

In accordance with the National Environmental Management Act (NEMA), the FSRs will be available for public comment and review from **Tuesday 18 August 2015 to Monday 7 September 2015** (end of business day). The FSRs are available on SiVEST's website: <http://www.sivest.co.za/> click on 'Downloads' (top right), then scroll down to *13031 Helena PV EIA*. Alternatively, please contact SiVEST to obtain an electronic copy of the reports on CD.

Should you have any comments on the FSRs, please submit these in writing directly to the DEA on or before **Monday 7 September 2015** (close of business day):

Department of Environmental Affairs (DEA)

Ms Mmatlala Rabothata

Private Bag X447

PRETORIA

0001

Tel: 012 399 9372

Email: mrabothata@environment.gov.za

As per the EIA Regulations, please send a copy of your comments to the SiVEST Office at the following address:

SiVEST Environmental

Andrea Gibb

PO BOX 2921

Rivonia

2128

Tel: 011 798 0600

Fax: 011 803 7272

Email: andreag@sivest.co.za

Kind Regards,

Andrea Gibb

Environmental Practitioner

SiVEST Environmental Division

Direct [+27 11 798 0638](tel:+27117980638) **Tel** [+27 11 798 0600](tel:+27117980600) **fax** [+27 11 803 7272](tel:+27118037272)

email AndreaG@sivest.co.za **website** www.sivest.co.za

Consulting Engineers - Project Managers - Environmental Consultants - Town and Regional Planners

Durban - Johannesburg - Pietermaritzburg - Richards Bay - Ladysmith - Cape Town - Harare (Zimbabwe)

Disclaimer

The information contained in this communication from the sender is confidential. It is intended solely for use by the recipient and others authorized to receive it. If you are not the recipient, you are hereby notified that any disclosure, copying, distribution or taking action in relation of the contents of this information is strictly prohibited and may be unlawful.

This email has been scanned for viruses and malware, and automatically archived by **Mimecast SA (Pty) Ltd**, an innovator in Software as a Service (SaaS) for business. **Mimecast Unified Email Management ??? (UEM)** offers email continuity, security, archiving and compliance with all current legislation. To find out more, [contact Mimecast](#).

Andrea Gibb

From: Andrea Gibb
Sent: Friday, December 04, 2015 7:44 AM
To: 'HettieB@daff.gov.za'
Cc: Lynsey Rimbault; Hlengiwe Ntuli
Subject: RE: Helena 1, 2 and 3 Solar PV Facilities: EIA Newsletter
Attachments: Helena Solar Title Deed - CTN - T18316_2008.pdf

Hi Hettie

Attached is the title deed document as requested.

Kind Regards

Andrea Gibb (B.Sc. Landscape Architecture; B.Sc.(Hons) Environmental Management)
Environmental Practitioner and Visual Specialist
SIVEST Environmental Division



SIVEST is a Level 3 BBBEE Contributor

Direct +27 11 798 0638 **Tel** +27 11 798 0600 **fax** +27 11 803 7272 **cell** +27 72 587 6525
email andrea@sivest.co.za **website** www.sivest.co.za



Consulting Engineers - Project Managers - Environmental Consultants - Town and Regional Planners
Durban - Johannesburg - Pietermaritzburg - Richards Bay - Ladysmith - Cape Town - Harare (Zimbabwe)

From: HettieB [<mailto:HettieB@daff.gov.za>]
Sent: 02 December 2015 11:16 AM
To: Hlengiwe Ntuli <HlengiweN@sivest.co.za>
Subject: RE: Helena 1, 2 and 3 Solar PV Facilities: EIA Newsletter

Good day
Please send me the title deed on this property.

Regards
Hettie Buys

From: Hlengiwe Ntuli [<mailto:HlengiweN@sivest.co.za>]
Sent: 30 November 2015 02:52 PM
Cc: Andrea Gibb; Lynsey Rimbault
Subject: Helena 1, 2 and 3 Solar PV Facilities: EIA Newsletter

***** Please note that this email was sent from a NO REPLY email address. Please do not reply to this address as it is an unmonitored email account. *****

Dear Stakeholder

We would like to take this opportunity to inform you that the Department of Environmental Affairs has accepted the Final Scoping Reports and approved the Plan of Study for the Environmental Impact Phase of the Helena 1, 2, and 3 Solar Photovoltaic Energy Facilities.

Attached is the EIA Newsletter, Comment form and Site Locality Map for your information.

Kind Regards

Andrea Gibb (B.Sc. Landscape Architecture; B.Sc.(Hons) Environmental Management) Environmental Practitioner and Visual Specialist SiVEST Environmental Division

SiVEST is a Level 3 BBBEE Contributor

Direct +27 11 798 0638 Tel +27 11 798 0600 fax +27 11 803 7272
email andreag@sivest.co.za website www.sivest.co.za

Consulting Engineers - Project Managers - Environmental Consultants - Town and Regional Planners
Durban - Johannesburg - Pietermaritzburg - Richards Bay - Ladysmith - Cape Town - Harare (Zimbabwe)

Disclaimer

The information contained in this communication from the sender is confidential. It is intended solely for use by the recipient and others authorized to receive it. If you are not the recipient, you are hereby notified that any disclosure, copying, distribution or taking action in relation of the contents of this information is strictly prohibited and may be unlawful.

This email has been scanned for viruses and malware, and automatically archived by **Mimecast SA (Pty) Ltd**, an innovator in Software as a Service (SaaS) for business. **Mimecast Unified Email Management ??? (UEM)** offers email continuity, security, archiving and compliance with all current legislation. To find out more, [contact Mimecast](#).

OIE EN OBPR VIR DIE VOORGESTELDE ONTWIKKELING VAN DRIE 75 MW FOTOVOLTAÏESE (FV) SONKRAGAAANLEGTE NABY COPPERTON, NOORD-KAAPPROVINSIE

- HELENA SOLAR 1 – DO Verw. No.: 14/12/16/3/3/2/765
- HELENA SOLAR 2 – DO Verw. No.: 14/12/16/3/3/2/766
- HELENA SOLAR 3 – DO Verw. No.: 14/12/16/3/3/2/767

REGISTRASIE- EN KOMMENTAARVORM

Vergesel die AgtergrondInligtingsdokument: 18 Februarie 2015



Openbare Deelnamekantoor



Andrea Gibb / Lynsey Rimbault
 SIVEST Environmental
 Posbus 2921, RIVONIA, 2128
 Tel: 011 798 0600
 Faks: 011 803 7272
 E-pos: andreag@sivest.co.za /
 lynseyr@sivest.co.za

Vul asseblief in teen Donderdag, 19 Maart 2015 en stuur dit per pos, faks of e-pos terug aan die Openbare Deelnamekantoor (soos hierbo).

TITEL	MNR.	VOORNAAM	FRANCOIS.
VOORLETTERS	F.P.	VAN	EKLERD
INSTANSIE	BOER. UITSAANREK		-
POSADRES	BUS 446	POSKODE	8940
TEL NO.	0833808427	FAKS NO.	

REGISTRASIE AS BELANGSTELLEDE EN/OF GEAFFEKTEERDE PARTY (B&GP) (omkring asseblief die toepaslike blokkie)

Registreer my asseblief formeel as 'n belangstellende en geaffekteerde party (B&GP) sodat ek verdere inligting en kennisgewings tydens die OIE-proses kan ontvang.	<input checked="" type="checkbox"/>	NEE
Ingevolge Staatskennisgewing R543 (2010 OIE-regulasies) maak ek hieronder enige regstreekse sake, finansiële, persoonlike of ander belang wat ek mag hê in die goedkeuring of afkeuring van die aansoek om omgewingsmagtiging bekend (gebruik gerus aparte bladsye indien u wil):		

KOMMENTAAR (gebruik gerus aparte bladsye indien u wil)

Ek stel voor dat die volgende knelpunte tydens die OIE ondersoek word:

.....

.....

Ek stel die volgende vir die OIE-proses en/of die openbare deelnameproses voor:

.....

.....

Enige ander kommentaar:

DIE PAD VANAF DIE R357 NA KLIPGATSPAN GED.1 MAGNIE GESLUIT WORD. DIT IS MY TOEGANGS ROETE TOT DIE GROND.

Tree asseblief in verbinding met my onderstaande kollegas/vriende om as B&GP's vir hierdie OIE te registreer (naam en kontakbesonderhede, bv. e-posadres):

.....

.....

Handtekening

DANKIE VIR U BYDRAE

Datum

Andrea Gibb

From: Lynsey Rimbault
Sent: Thursday, May 28, 2015 11:54 AM
To: fjandreas.fa@gmail.com; andrea@eskom.co.za
Cc: Andrea Gibb; Irene Bezuidenhout
Subject: RE: Bio Therm solar project

Hi Frank,

SiVEST is the Environmental Impact Assessment Practitioner on the Helena projects. We are responsible for assessing the environmental impact of the project, but we are not involved in the project development at all.

I have forwarded your email to Irene Bezuidenhout from BioTherm Energy. She can direct you to the correct person to address your enquiry to.

Kind Regards

Lynsey Rimbault (B.Sc.(Hons) Geography; M.Sc. Biodiversity, Conservation and Management)
Environmental Consultant
SiVEST Environmental



SiVEST is a Level 3 BBEE Contributor

Direct +27 11 798 0631 Tel +27 11 798 0600 fax +27 11 803 7272 cell +27 82 669 9558
email lynseyr@sivest.co.za website www.sivest.co.za



Consulting Engineers - Project Managers - Environmental Consultants - Town and Regional Planners
Durban - Johannesburg - Pietermaritzburg - Richards Bay - Ladysmith - Cape Town - Harare (Zimbabwe)

From: Frank Andreas [mailto:fjandreas.fa@gmail.com]
Sent: 26 May 2015 11:16
To: andreaq@sivest.co.za; andrea@eskom.co.za; Lynsey Rimbault
Subject: Bio Therm solar project

Hi

In terms of the presentation presented in Prieska community hall for the Prieska community refer to the construction part of your project for Bio Therm Energy.

We have a construction company wick are interested to do construction work on your plant in order to compliment local based Bee representation and what we want is information to enter such discussions into a contract.

Do you already appoint a main contractor for the establishment to which we can apply and negotiate subcontracting work for or is there scope to apply for the construction job directly to Sivest.

Please guide me through that process and do not hesitate to contact me on my cell: 081 098 9446 for any feedback regarding the project.

Regards
Frank Andreas

F.P Ekkerd
Posbus 446
Prieska
8940

7 Julie 2015

Si Vest Environmental
Posbus 2921
Rivona 2128
Faks: 011 803 7272
Epos: andreaag@sivest.co.za

BEOOGDE: P.V SONKRAG AANGLEGTE TE KLIPPAN N.C. HELENA SOLAR
1.2.3

Ek eenaar van die naby geleë plaas Uitspanpan beskou myself as 'n groene. Op die plaas bedryf ek al vir die afgelope 25 jaar my eie sonkrag stelsel. Ek is baie bly en opgewonde oor die aanlegte wat hier opgerig sal word. Voor my afgetrede as ingenieur het ek verskeie hidroelektriese skemas vir boere uitgewerk net om van die tafel af gegee te word deur Eskom en samespanning met die Department van Waterwese.

Dit is ook dat enige ontwikkeling tot voordeel van die hele gemeenskap sover moontlik moet strek. President Zuma het onlangs 'n beroep op sakelui gedoen om in die platteland te belê sodoende sal armoede en werkloosheid bekamp word. Dit is ook my uitgangspunt om daar toe 'n bydrae te lewer hoe klein ook al. So het die paaië afdeling kosteloos water op my plaas onttrek asook was die verwydering van gruis uit die leengroewe kosteloos. Ek beskou die werk van die paaië afdeling as 'n vooruitgang vir die gemeenskap.

So het ek dan ook water kosteloos verskaf aan die kontrakteur by een van die terreine waar daar werk aan die gang is vir die sonplaas. Die ontwikkeling gaan ook nie gepaard sonder probleme nie. Daar word tans beoog om 24 sonplase (1 windplaas) hier te ontwikkel en dit net op 4 plase.

Die gemeenskap voel ongelukkig oor die toedrag van sake en bepleit 'n beter regverdiige verdeling. As die verdeling oor 24 plase geskied sal dit 'n groter ekonomiese impak op die omgewing en dorp hê. Die aantal plase sal maklik byvoorbeeld 150 arbeiders of huishoudings kan absorbeer terwyl 4 plase sowat 20 mense sal absorbeer. Om 'n stelling te maak en te sê dit is nie ekonomies haalbaar nie is geen rede nie. As ek kyk en ek sien die daaglikse korrupsie jaloesie en rugstekery wat hier plaasvind dan is daar beslis nie 'n tekort aan geld nie. Alles word onder dekmantel van BEE gedoen. BEE het 'n rookskerm vir korrupsie geword. Ek self was 'n slagoffer van so 'n komplot en het dit my baie kostes uit die sak gejaag om die teendeel te bewys. Ek het 'n swart vennoot (hy het terloops op die plaas Klippan groot geword en sy vader is daar begrawe).

Ten einde my vennoot te help het ek gevra om die heinings by die sonplase te span. Dit is my geweer want ek wou nie geld betaal nie. Daar is glo 'n kontrakteur wat dit doen en hy vlieg met helikopter. Dit is die eerste draadkamper wat ek hoor wat met 'n helikopter vlieg.

Ek wil u dus in kennis stel dat ek ernstig beswaar daarteen het vir die oprigting van 3 sonaanglegte te Klippan. Die aanglegte moet in Noord-Suid na 'n Oos-Wes rigting gedraai word. Die aanlegte sal dan oor 3 plase strek n.l. Klippan, Irene en Uitspanpan. Die probleem of ek eerder sê die vooruitgang wat hierdie aanlegte te weeg kan bring is astronomies as dit reg hanteer word. Die aanlegte is alreeds met Afriforum en Solidariteit opgeneem en ons wag op sekere skrywe. Daar was tot soveer geen blankes in diens geneem nie en die uit die agtergeblewende gemeenskappe is minimaal. Dit wat ek hier vermeld het is alles op terrein waarneembaar. Met elke konstruksie van die 3 aangegte sal hierdie slegte dinge ook nie vry gespring word. Wag op u antwoord.

Die Uwe



E.P. EKKERD

F.P Ekkerd
P.O. Box 446
Prieska
8940

7 July 2015

SiVEST Environmental
P.O. Box 2921
Rivonia 2128
Fax: 011 803 7272
Email: andreag@sivest.co.za

PLANNED: PV SOLAR POWER FACILITY/PLANT AT THE FARM KLIPPAN NC. HELENA SOLAR 1, 2, 3.

I, the owner of the nearby situated Farm Uitspanpan, regard myself as a "greenie". For the past 25 years I have been running/maintaining my own solar power facility / unit on my/the farm. I am very pleased and excited about the new/planned facility/plant that is to be constructed here. Before my retirement as an Engineer, I proposed various hydroelectric schemes/systems for farmers just to have them scrapped (from the table) by Eskom in co-operation/association with the Department of Water Affairs.

It must be said that any development should also be in the best interest of/advantageous to the entire community so far as possible. President Zuma recently appealed to entrepreneurs/businessmen/businesses to invest in the country/ rural or pastoral communities in order to fight against poverty and unemployment. It is also my point to make a contribution towards this, however small it may be. The Department of Roads/Roadworks therefore withdrew water from my farm free of charge and the removal of debris from the borrow pits was also done free of charge. I consider the work of the Department of Roads/Roadworks to be progress for the community.

I also supplied/ distributed water free of charge to the Contactor at one of the sites where work is being done on the Solar Facility/Solar Farm. The development is also not without its issues. It is currently contemplated/ planned to develop/construct 24 Solar Facilities/Solar farms (1 Wind farm), and all of this on just 4 farms.

The community feels unhappy about the state of affairs and advocate/support a better, equitable distribution. If the distribution (of the facilities) is made over 24 farms it will have a bigger economic impact/effect on the community and the town. This number of farms will easily be able to absorb/support 150 workers or households while 4 farms will only absorb about 20 people/individuals. To make a statement by saying that it is not economically feasible is no reason at all. If I look and see the daily corruption, jealousy, and backstabbing that takes place here then there is definitely/surely no shortage of money. Everything is done under cover of BEE. BEE has become a "smoke-screen" for corruption. I myself was a victim of such a plot/conspiracy and it cost me a lot of money to prove the contrary. I have a black partner (he grew up on the Farm Klippan and his father is buried there).

In order to help my partner I asked to erect/span the fences at the Solar Facilities/ Solar Farms. I was refused this because/as I did not want to pay money. There is apparently a Contractor which is in charge of/doing this (the fencing) and he flies with a helicopter. This is the first fencing person (draadkammer is somebody who does fences) I hear of that flies with a helicopter.

I therefore want to inform you that I strongly objected to the erection/installation/construction of the 3 Solar Facilities/plants at Klippan. The Facilities/plants must be turned North-South in an East-West direction. The Facilities/plants will then stretch over 3 farms, namely Klippan, Irene and Uitspanpan. The problem, or let me rather say the progress, that these Facilities/plants can bring/produce is astronomical if it is handled correctly. The issue of the Facilities/Plants has already been taken up with Afriforum and Solidarity (Solidaritet) and we are currently waiting for certain letters. So far there have been no white individuals that have been employed and those that have been employed from disadvantaged communities are minimal. Everything I have mention here is perceptible/visible on site. With the construction of each of the 3 facilities/plants, these bad things/issues will not be avoided. Awaiting your reply.

Yours truly,

E.P EKKERD

Andrea Gibb

Subject: FW: Helena 1, 2 and 3 Landowner FGM Draft Minutes

From: Gerrie Rudolph [<mailto:gerrierudolph@vodamail.co.za>]
Sent: 08 July 2015 06:48 PM
To: Veronique Evans <VeroniqueE@sivest.co.za>
Subject: Re: Helena 1, 2 and 3 Landowner FGM Draft Minutes

Hi Veronique,
I see that a CD has been posted during May 2015 to me of which up to date I have not received.
I have cleared y post today and nothing of that sorts was found.
Kind regards.
Gerrie

From: [Veronique Evans](#)
Sent: Wednesday, July 08, 2015 2:37 PM
Cc: [Danie & Jomima Bernard](#) ; [Jermaine Isaacs](#) ; [Chetna Mistry](#) ; [Irene Richardson](#) ; [Lynsey Rimbault](#) ; [Gerrie Rudolph](#) ; [Lynsey Rimbault](#) ; [Andrea Gibb](#)
Subject: Helena 1, 2 and 3 Landowner FGM Draft Minutes

******* Please note that this email was sent from a NO REPLY email address. Please do not reply to this address as it is an unmonitored email account. *******

Dear Stakeholder,

Please see attached the Draft Minutes for the Landowner Focus Group Meeting held at letznietz Guest House, Copperton on Friday the 22nd of May 2015.

Please submit your comments on the Draft Minutes on or before Wednesday 15 July 2015.

Kind Regards

Andrea Gibb (B.Sc. Landscape Architecture; B.Sc.(Hons) Environmental Management)
Environmental Practitioner and Visual Specialist
SiVEST Environmental Division



SiVEST is a Level 3 BBBEE Contributor

Direct +27 11 798 0638 **Tel** +27 11 798 0600 **fax** +27 11 803 7272 **cell** +27 72 587 6525
email andrea@sivest.co.za **website** www.sivest.co.za

Consulting Engineers - Project Managers - Environmental Consultants - Town and Regional Planners
Durban - Johannesburg - Pietermaritzburg - Richards Bay - Ladysmith - Cape Town - Harare (Zimbabwe)

Disclaimer

The information contained in this communication from the sender is confidential. It is intended solely for use by the recipient and others authorized to receive it. If you are not the recipient, you are hereby notified that any disclosure, copying, distribution or taking action in relation of the contents of this information is strictly prohibited and may be unlawful.

This email has been scanned for viruses and malware, and automatically archived by **Mimecast SA (Pty) Ltd**, an innovator in Software as a Service (SaaS) for business. **Mimecast Unified Email Management ??? (UEM)** offers email continuity, security, archiving and compliance with all current legislation. To find out more, [contact Mimecast](#).

M&M VAN NIEKERK

Prokureurs en Transportbesorgers
(voorheen Van Niekerk & Groenewoud)

Old Mutual Gebou
Kerkstraat
Prieska 8940

Posbus 34, Prieska, 8940
Tel: (053) 353 1131
Faks: (053) 353 2344
E-pos: vankerk@mjvn.co.za

Ons verwysing: FJ LOTZ / ep/EKK1/0001

U verwysing: 13031

23 NOVEMBER 2015

SIVEST
RIVONIA

PER FAX: (011) 803 7272

ENVIRONMENTAL IMPACT ASSESSMENT: HELENA SOLAR 1; 2 & 3

We attach hereto letter from yourselves received by our client Mr FP Ekkerd.

Mnr Ekkerd consequently replied to your letter on 7 July 2015 of which letter we also attach a copy hereto.

Please provide us with your response thereto as a matter of urgency.

Die uwe



M & M VAN NIEKERK ING.

SIVEST
Environmental

51 Wessel Road, Rivonia
PO Box 2921, Rivonia
2128
Gauleng, South Africa

Phone + 27 11 798 0600
Fax + 27 11 803 7272
Email info@sivest.co.za
www.sivest.co.za



Established 1952

Your reference	N/A
Our reference	13031
Date	18 February 2015

Dear Interested and/or Affected Party

ENVIRONMENTAL IMPACT ASSESSMENT (EIA) AND ENVIRONMENTAL MANAGEMENT PROGRAMME (EMPr) FOR THE PROPOSED DEVELOPMENT OF THREE 75MW SOLAR PHOTOVOLTAIC (PV) ENERGY FACILITIES NEAR COPPERTON, NORTHERN CAPE PROVINCE (HELENA SOLAR 1 – DEA Ref No: 14/12/16/3/3/2/765, HELENA SOLAR 2 – DEA Ref No: 14/12/16/3/3/2/766, HELENA SOLAR 3 – DEA Ref No: 14/12/16/3/3/2/767)

• INVITATION TO PARTICIPATE IN THE ENVIRONMENTAL IMPACT ASSESSMENT PROCESS

In terms of the EIA Regulations and the National Environmental Management Act, 1998 (Act No. 107 of 1998), SIVEST SA (Pty) Ltd (hereafter referred to as SIVEST) has been appointed as the independent Environmental Assessment Practitioner (EAP) by BioTherm Energy (Pty) Ltd (hereafter referred to as BioTherm) to conduct the EIA process for the proposed development of a three phase solar photovoltaic (PV) energy facility with a total export capacity of 225MW. The proposed project is located in the Northern Cape Province near Copperton and will consist of three 75MW export capacity solar PV facilities referred to as Helena Solar 1, 2 and 3. The project is registered with the Department of Environmental Affairs (DEA) under the following reference numbers:

- Helena Solar 1 – DEA Ref No: 14/12/16/3/3/2/765
- Helena Solar 2 – DEA Ref No: 14/12/16/3/3/2/766
- Helena Solar 3 – DEA Ref No: 14/12/16/3/3/2/767

SIVEST would like to invite you, as a potential Interested and/or Affected Party (I&AP), to become actively involved in the EIA and public participation process for this proposed project. The aim of this process are as follows:

- to ensure that all the relevant environmental impacts are taken into consideration;
- to ensure public input; and
- provide decision-makers with sufficient information to make an informed decision on the proposed activities.

Attached is the BID which contains information regarding the proposed project as well as the EIA and public participation process.

By completing and submitting the accompanying registration and comment form, you will be registered as an I&AP on the project database.

We would like to thank you, in advance, for becoming part of the public participation process and are looking forward to receiving your valuable comments relating to the proposed project.

Yours sincerely

Andrea Gibb
Environmental Practitioner
SIVEST Environmental Division

encl: Background Information Document
Registration and Comment Form

F.P Ekkerd
Posbus 446
Prieska
8940

7 Julie 2015

Si Vest Environmental
Posbus 2921
Rivona 2128
Faks: 011 803 7272
Epos: andreag@sivest.co.za

BEOOGDE: P.V SONKRAG AANGLEGTE TE KLIPPAN NC. HELENA SOLAR
1, 2, 3

Ek eienaar van die naby geleë plaas Uitspanpan beskou myself as 'n groene. Op die plaas bedryf ek al vir die afgelope 25 jaar my eie sonkrag stelsel. Ek is baie bly en opgewonde oor die aanlegte wat hier opgerig sal word. Voor my afgetrede as ingenieur het ek verskeie hidroelektriese skemas vir boere uitgewerk net om van die tafel af gegee te word deur Eskom en samespanning met die Department van Waterwese.

Dit is ook dat enige ontwikkeling tot voordeel van die hele gemeenskap sover moontlik moet strek. President Zuma het onlangs 'n beroep op sakelui gedoen om in die platteland te belê sodoende sal armoede en werkloosheid bekamp word. Dit is ook my uitgangspunt om daar toe 'n bydrae te lewer hoe klein ook al. So het die paaie afdeling kosteloos water op my plaas onttrek asook was die verwydering van gruis uit die leengroewe kosteloos. Ek beksou die werk van die paaie afdeling as 'n vooruitgang vir die gemeenskap.

So het ek dan ook water kosteloos verskaf aan die kontrakteur by een van die terreine waar daar werk aan die gang is vir die sonplaas. Die ontwikkeling gaan ook nie gepaard sonder probleme nie. Daar word tans beoog om 24 sonplase (1 windplaas) hier te ontwikkel en dit net op 4 plase.

Die gemeenskap voel ongelukkig oor die toedrag van sake en bepleit 'n beter regverdige verdeling. As die verdeling oor 24 plase geskied sal dit 'n groter ekonomiese impak op die omgewing en dorp hê. Die aantal plase sal maklik byvoorbeeld 150 arbeiders of huishoudings kan absorbeer terwyl 4 plase sowat 20 mense sal absorbeer, Om 'n stelling te maak en te sê dit is nie ekonomies haalbaar nie is geen rede nie. As ek kyk en ek sien die daaglikse korrupsie jaloesie en rugstekery wat hier plaasvind dan is daar beslis nie 'n tekort aan geld nie. Alles word onder dekmantel van BEE gedoen. BEE het 'n rookskerm vir korrupsie geword. Ek self was 'n slagoffer van so 'n komplot en het dit my baie kostes uit die sak gejaag om die teendeel te bewys. Ek het 'n swart vennoot (hy het terloops op die plaas Klippan groot geword en sy vader is daar begrawe).

Ten einde my vennoot te help het ek gevra om die heinings by die sonplase te span. Dit is my geweier want ek wou nie geld betaal nie. Daar is glo 'n kontrakteur wat dit doen en hy vlieg met helikopter. Dit is die eerste draadkamper wat ek hoor wat met 'n helikopter vlieg.

Ek wil u dus in kennis stel dat ek ernstig beswaar daarteen het vir die oprigting van 3 sonaanglegte te Klippan. Die aanlegte moet in Noord-Suid na 'n Oos-Wes rigting gedraai word. Die aanlegte sal dan oor 3 plase strek nl. Klippan, Irene en Uitspanpan. Die probleem of ek eerder sê die vooruitgang wat hierdie aanlegte te weeg kan bring is astronomies as dit reg hanteer word. Die aanlegte is alreeds met Afriforum en Solidariteit opgeneem en ons wag op sekere skrywe. Daar was tot soveer geen blankes in diens geneem nie en die uit die agtergeblewende gemeeskappe is minimaal. Dit wat ek hier vermeld het is alles op terrein waarneembaar. Met elke konstruksie van die 3 aangelegte sal hierdie slegte dinge ook nie vry gespring word. Wag op u antwoord.

Die Uwe



E.P EKKERD

Figure 1: Locality Map / Figuur 1: Liggingkaart

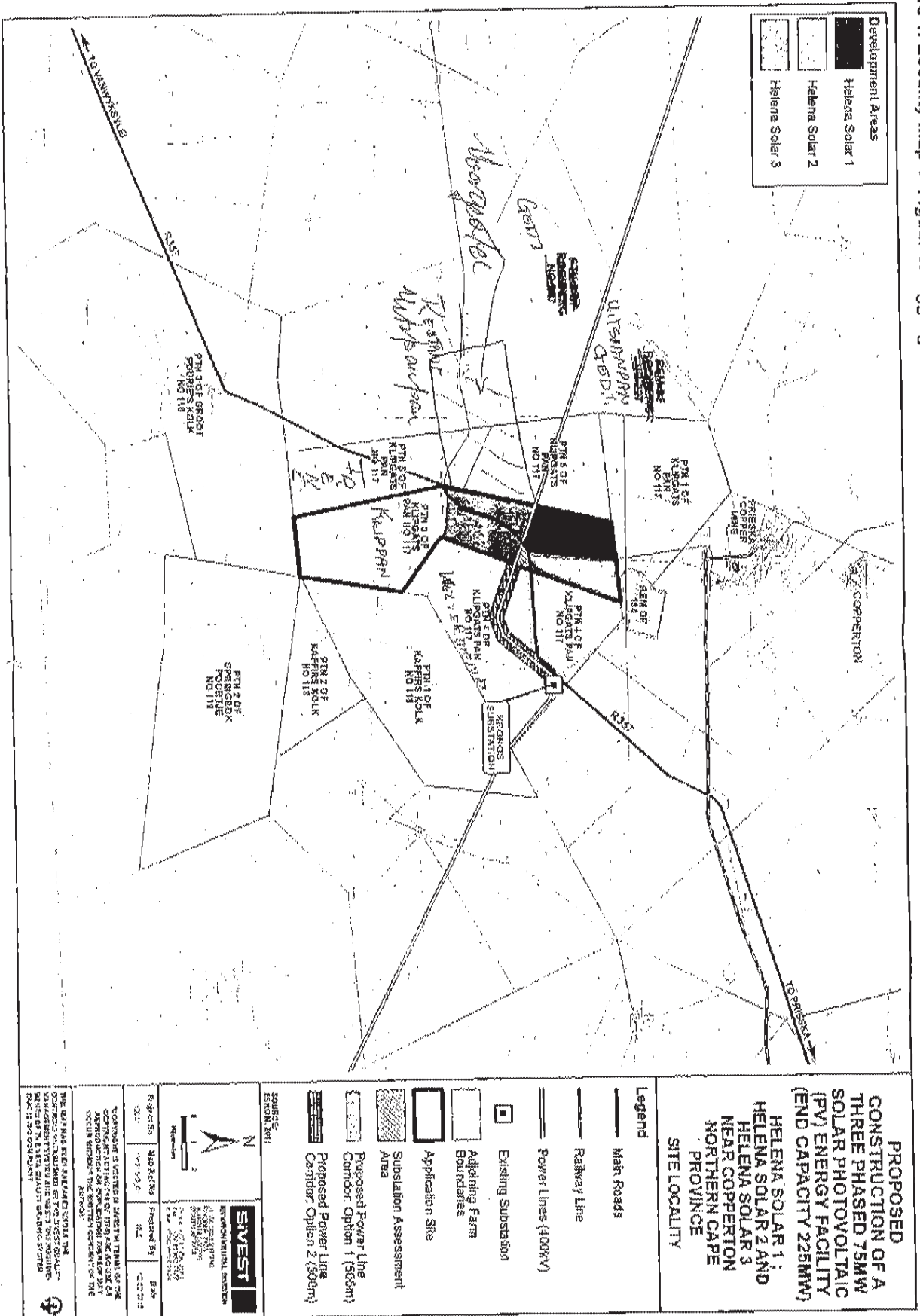

THANK YOU FOR YOUR CONTRIBUTION

Signature

Date

05/01/2016

Firstly, I need to inform you that I did submit my CV for a position at the project office in Pisto around April 2015. Until now, I was not contacted and that is surprising to me because a lot of applicants around me have been employed since we went to apply at the same time. I have experience in Advanced Driving Truck operation I also have experience working with a team without supervision. My experience in security also contributes to my skills. Therefore I am applying for a position as a manager on 1 of any of the abovementioned sites.

I have the following issues and concerns regarding the EIA Newsletter, EIA Process or Helena 1/Helena 2/Helena 3 project (kindly specify the project you are enquiring for):

NGO-Managerial position in on of abovementioned sites

COMMENTS: (You are welcome to use a separate sheet if required)

TITLE	Mr
INITIALS	T.C.
ORGANISATION	Personal
POSTAL ADDRESS	P.O. Box 284 Pisto
TEL NO	Cell # 0724425955/FAX NO
FIRST NAME	Themba
SURNAME	NOHENDI
EMAIL	thembano@gmail.com
POSTAL CODE	8940

Please complete and return to the Public Participation Office (as above)

WE WOULD WELCOME YOUR COMMENTS ON THE EIA NEWSLETTER

<p>ENVIRONMENTAL IMPACT ASSESSMENT (EIA) AND ENVIRONMENTAL MANAGEMENT PROGRAMME (EMPM) FOR THE THREE HELENA SOLAR PHOTOVOLTAIC (PV) ENERGY FACILITIES NEAR COPPERTON, NORTHERN CAPE PROVINCE</p> <p>HELENA SOLAR 1: 14/12/16/3/3/21765 HELENA SOLAR 2: 14/12/16/3/3/21766 HELENA SOLAR 3: 14/12/16/3/3/21767</p> <p>COMMENT FORM</p> <p>EIA NEWSLETTER</p>	<p>DEA Ref.</p>
<p>SIVEST</p> <p>Public Participation Office</p>	<p>Andrea Gibb / Lynsey Rimbault SIVEST Environmental PO Box 2921, RIVONIA, 2128 Tel (011) 798 0800 Fax (011) 803 7272 Email andrea@sivest.co.za / lynsey@sivest.co.za</p>

Andrea Gibb

Subject: FW: 13031 Helena PV Project Update

From: Melanie Miles [<mailto:MelanieM@L2B.co.za>]

Sent: 04 August 2016 04:15 PM

To: Kelly Tucker <KellyT@sivest.co.za>

Subject: 13031 Helena PV Project Update

Dear Kelly,

Further to our correspondence below with Lynsey, please could you advise if the Helena PV Projects remain on hold?

I look forward to your response

Kindest Regards,

Melanie Miles
Regional Content Researcher
Private Projects
MelanieM@L2B.co.za

Leads 2 Business (www.L2B.co.za)

Tel: 033 343 1130 or 0860 836337 (0860 TENDER)

Fax: 033 343 5882

This e-mail is for the intended addressee only. If you have received it in error, please notify the sender by e-mail. Dissemination or copying is prohibited unless permitted by the sender, and then only by the intended addressee. Whilst reasonable measures are used to guard against the transmission of malicious code, no liability is accepted for its transmission. If this e-mail is not related to the business of Cedrus Internet Solutions (Pty) Ltd, it is sent by the above mentioned in their individual capacity and not on behalf of Cedrus Internet Solutions (Pty) Ltd.

Please note that any views expressed in this email may be those of the originator and do not necessarily reflect those of Cedrus Internet Solutions (Pty) Ltd.

On 20/02/2016 09:06, Lynsey Rimbault wrote:

Hi Melanie,

I am responding to your telephonic query regarding the status of the Helena Solar PV projects near Copperton.

The Draft Environmental Impact Assessment Reports (DEIARs) were available for review from Wednesday 9 December 2015 to Wednesday 27 January 2016. Following discussion with the SKA during the comment period the project has been placed temporarily on hold.

When the project does continue, public meetings will be held as usual and the FEIARs will be submitted to the DEA. I will ensure that you are on the project database and are notified about any project developments.

Kind Regards
Lynsey

Lynsey Rimbault (B.Sc.(Hons) Geography; M.Sc. Biodiversity, Conservation and Management)
Environmental Consultant
SiVEST Environmental



SiVEST is a Level 3 BBBEE Contributor



Direct +27 11 798 0631 Tel +27 11 798 0600 fax +27 11 803 7272 cell +27 82 669
9558
email lynseyr@sivest.co.za website www.sivest.co.za

Consulting Engineers - Project Managers - Environmental Consultants - Town and Regional Planners
Durban - Johannesburg - Pietermaritzburg - Richards Bay - Ladysmith - Cape Town - Harare (Zimbabwe)

Disclaimer

The information contained in this communication from the sender is confidential. It is intended solely for use by the recipient and others authorized to receive it. If you are not the recipient, you are hereby notified that any disclosure, copying, distribution or taking action in relation of the contents of this information is strictly prohibited and may be unlawful.

This email has been scanned for viruses and malware, and automatically archived by **Mimecast SA (Pty) Ltd**, an innovator in Software as a Service (SaaS) for business. **Mimecast Unified Email Management ??? (UEM)** offers email continuity, security, archiving and compliance with all current legislation. To find out more, [contact Mimecast](#).

No virus found in this message.

Checked by AVG - www.avg.com

Version: 2016.0.7442 / Virus Database: 4533/11676 - Release Date: 02/22/16

Andrea Gibb

From: Andrea Gibb
Sent: Friday, August 05, 2016 9:01 AM
To: MelanieM@L2B.co.za
Subject: RE: 13031 Helena PV Project Update

Hi Melanie

I can confirm that the Helena PV Projects are still on hold. The applicant is currently busy undertaking additional emission control studies which will likely be complete in October this year. The FEIARs will thereafter be updated and made available for review before submission to the DEA.

Kind Regards

Andrea Gibb (B.Sc. Landscape Architecture; B.Sc.(Hons) Environmental Management)
Environmental Practitioner and Visual Specialist
SIVEST Environmental Division



SIVEST is a Level 3 BBBEE Contributor

Direct +27 11 798 0638 **Tel** +27 11 798 0600 **fax** +27 11 803 7272 **cell** +27 72 587 6525
email andrea@sivest.co.za **website** www.sivest.co.za



Consulting Engineers - Project Managers - Environmental Consultants - Town and Regional Planners
Durban - Johannesburg - Pietermaritzburg - Richards Bay - Ladysmith - Cape Town - Harare (Zimbabwe)

From: Melanie Miles [<mailto:MelanieM@L2B.co.za>]

Sent: 04 August 2016 04:15 PM

To: Kelly Tucker <KellyT@sivest.co.za>

Subject: 13031 Helena PV Project Update

Dear Kelly,

Further to our correspondence below with Lynsey, please could you advise if the Helena PV Projects remain on hold?

I look forward to your response

Kindest Regards,

Melanie Miles
Regional Content Researcher
Private Projects
MelanieM@L2B.co.za

Leads 2 Business (www.L2B.co.za)

Tel: 033 343 1130 or 0860 836337 (0860 TENDER)
Fax: 033 343 5882

This e-mail is for the intended addressee only. If you have received it in error, please notify the sender by e-mail. Dissemination or copying is prohibited unless permitted by the sender, and then only by the intended addressee. Whilst reasonable measures are used to guard against the transmission of malicious code, no liability is accepted for its transmission. If this e-mail is not related to the business of Cedrus Internet Solutions (Pty) Ltd, it is sent by the above mentioned in their individual capacity and not on behalf of Cedrus Internet Solutions (Pty) Ltd.

Please note that any views expressed in this email may be those of the originator and do not necessarily reflect those of Cedrus Internet Solutions (Pty) Ltd.

On 20/02/2016 09:06, Lynsey Rimbault wrote:

Hi Melanie,

I am responding to your telephonic query regarding the status of the Helena Solar PV projects near Copperton.

The Draft Environmental Impact Assessment Reports (DEIARs) were available for review from Wednesday 9 December 2015 to Wednesday 27 January 2016. Following discussion with the SKA during the comment period the project has been placed temporarily on hold.

When the project does continue, public meetings will be held as usual and the FEIARs will be submitted to the DEA. I will ensure that you are on the project database and are notified about any project developments.

Kind Regards
Lynsey

Lynsey Rimbault *(B.Sc.(Hons) Geography; M.Sc. Biodiversity, Conservation and Management)*
Environmental Consultant
SiVEST Environmental



SiVEST is a Level 3 BBBEE Contributor



Direct +27 11 798 0631 Tel +27 11 798 0600 fax +27 11 803 7272 cell +27 82 669 9558
email lynseyr@sivest.co.za website www.sivest.co.za

Consulting Engineers - Project Managers - Environmental Consultants - Town and Regional Planners
Durban - Johannesburg - Pietermaritzburg - Richards Bay - Ladysmith - Cape Town - Harare (Zimbabwe)

Disclaimer

The information contained in this communication from the sender is confidential. It is intended solely for use by the recipient and others authorized to receive it. If you are not the recipient, you are hereby notified that any disclosure, copying, distribution or taking action in

relation of the contents of this information is strictly prohibited and may be unlawful.

This email has been scanned for viruses and malware, and automatically archived by **Mimecast SA (Pty) Ltd**, an innovator in Software as a Service (SaaS) for business. **Mimecast Unified Email Management ??? (UEM)** offers email continuity, security, archiving and compliance with all current legislation. To find out more, [contact Mimecast](#).

No virus found in this message.

Checked by AVG - www.avg.com

Version: 2016.0.7442 / Virus Database: 4533/11676 - Release Date: 02/22/16

Lynsey Rimbault

From: Lynsey Rimbault
Sent: 20 February 2016 09:06
To: 'Melaniem@l2b.co.za'
Cc: Rebecca Thomas
Subject: 13031 Helena PV Project Update

Hi Melanie,

I am responding to your telephonic query regarding the status of the Helena Solar PV projects near Copperton.

The Draft Environmental Impact Assessment Reports (DEIARs) were available for review from Wednesday 9 December 2015 to Wednesday 27 January 2016. Following discussion with the SKA during the comment period the project has been placed temporarily on hold.

When the project does continue, public meetings will be held as usual and the FEIARs will be submitted to the DEA. I will ensure that you are on the project database and are notified about any project developments.

Kind Regards
Lynsey

Lynsey Rimbault *(B.Sc.(Hons) Geography; M.Sc. Biodiversity, Conservation and Management)*
Environmental Consultant
SiVEST Environmental



SiVEST is a Level 3 BBBEE Contributor

Direct +27 11 798 0631 **Tel** +27 11 798 0600 **fax** +27 11 803 7272 **cell** +27 82 669 9558
email lynseyr@sivest.co.za **website** www.sivest.co.za



Consulting Engineers - Project Managers - Environmental Consultants - Town and Regional Planners
Durban - Johannesburg - Pietermaritzburg - Richards Bay - Ladysmith - Cape Town - Harare (Zimbabwe)

Andrea Gibb

From: Nicolene Venter <nicolenev@zitholele.co.za>
Sent: Tuesday, August 04, 2015 6:19 AM
To: Gerrie Rudolph
Cc: Andrea Gibb; Lynsey Rimbault
Subject: Helena 1, 2 & 3: Final Scoping Report on CD

More Gerrie,

Die verslag, op CD, is gestuur. Jy kan op die Poskantoor se webwerf trek waar die pakkie is – die “tracking number” is RD 600 059 254 ZA.

Kind Regards,

Nicolene Venter [Cert. Public Relations]

Senior Public Participation Practitioner

Building 1, Maxwell Office Park, Magwa Crescent West, cnr Allandale Road & Maxwell Drive, Waterfall City, Midrand, RSA

T: +27 11 207 2060 **D:** +27 11 207 2077 **F:** +27 86 676 9950 **C:** +27 83 377 9112

E: nicolenev@zitholele.co.za **W:** www.zitholele.co.za



Please consider the environment before printing this e-mail!



PORTION 3 OF THE FARM KLIPGATS PAN 117
PO Box 528
PRIESKA
8940

Your reference:

Our reference: 13031

Date: 29 May 2015

ATTENTION: GERRRIE RUDOLPH

Via Post

Dear Gerrie Rudolph

ENVIRONMENTAL IMPACT ASSESSMENT (EIA) FOR THE PROPOSED CONSTRUCTION OF THREE 75MW HELENA SOLAR PHOTOVOLTAIC (PV) ENERGY FACILITIES NEAR COPPERTON, NORTHERN CAPE PROVINCE

DEA REFERENCE NO.:

- **HELENA SOLAR 1: 14/12/16/3/3/2/765**
- **HELENA SOLAR 2: 14/12/16/3/3/2/766**
- **HELENA SOLAR 3: 14/12/16/3/3/2/767**

You indicated at the Landowner meeting held on the 22nd of May 2015 that you would like to receive a copy of the Draft Scoping Reports (DSRs) on CD. Please see enclosed a DVD containing all three DSRs, including all appendices.

Yours sincerely

A handwritten signature in black ink, appearing to read "Andrea Gibb".

Andrea Gibb
Environmental Practitioner
SIVEST Environmental Division

Attached: 1 X Electronic copy (on CD) of the DSRs for the three Helena projects, including appendices

Lynsey Rimbault

From: Lynsey Rimbault
Sent: 26 March 2015 11:17 AM
To: 'george.karsten@arm.co.za'
Cc: Andrea Gibb; 'Nicolene Venter'
Subject: Proposed Solar Facility on Klipgatspan No 117 Portion 3 and 4
Attachments: 13031 BID (AFR) FEB 2015.pdf; 13031 BID (ENG) FEB 2015.pdf; A3_13031_SiteLocality.pdf

Dear Mr George Karsten,

To refer to your telephone call with my colleague Nicolene Venter, please see attached the Background Information Document and cadastral map for the proposed solar facility on Klipgatspan No 117 Portion 3 and 4.

Please do not hesitate to contact us with any questions.

Kind Regards

Lynsey Rimbault *(B.Sc.(Hons) Geography; M.Sc. Biodiversity, Conservation and Management)*
Environmental Consultant
SiVEST Environmental



SiVEST is a Level 3 BBBEE Contributor

Direct +27 11 798 0631 **Tel** +27 11 798 0600 **fax** +27 11 803 7272 **cell** +27 82 669 9558
email lynseyr@sivest.co.za **website** www.sivest.co.za



Consulting Engineers - Project Managers - Environmental Consultants - Town and Regional Planners
Durban - Johannesburg - Pietermaritzburg - Richards Bay - Ladysmith - Cape Town - Harare (Zimbabwe)



Appendix 5E: Comments and Response Report



Appendix 5F: I&AP Database



**Appendix 5G:
Meeting Minutes**



**ENVIRONMENTAL IMPACT
ASSESSMENT (EIA) AND
ENVIRONMENTAL MANAGEMENT
PROGRAMME (EMPr) FOR THE
PROPOSED DEVELOPMENT OF
THREE 75MW SOLAR PHOTOVOLTAIC
(PV) ENERGY FACILITIES NEAR
COPPERTON, NORTHERN CAPE
PROVINCE**

**FINAL MINUTES OF THE
FOCUS GROUP MEETING**

Landowners

**Held on
Friday, 22 May 2015 at 09h00
letznietz Guest House, Copperton**

Northern Cape Province

SiVEST Environmental (Pty) Ltd

Contact: Andrea Gibb / Lynsey Rimbault

Address: PO Box 2921
51 Wessels Road
Rivonia 2128

Tel: 011 798 0600

Fax: 011 803 7272

E-mail: andreag@sivest.co.za
lynseyr@sivest.co.za

Final Minutes prepared by:

Lynsey Rimbault

TABLE OF CONTENTS

1	WELCOME, INTRODUCTIONS.....	1
2	MEETING ATTENDEES	1
3	PURPOSE OF THE MEETING	1
4	PROJECT CONTEXT AND OVERVIEW	1
5	DISCUSSION SESSION AND QUESTIONS.....	1
6	CLOSURE AND WAY FORWARD.....	2

FOCUS GROUP MEETING

Venue: Ietznietz Guest House, Copperton
Date: Friday, 22 May 2015
Time: 09h00 – 13h00

1 WELCOME, INTRODUCTIONS

Nicolene Venter welcomed everyone who attended the Focus Group Meeting (FGM). She introduced the representatives from SiVEST, Zitholele and BioTherm Energy at the meeting, noting that SiVEST is the independent Environmental Assessment Practitioner (EAP) undertaking the Environmental Impact Assessment (EIA) process.

2 MEETING ATTENDEES

The Focus Group Meeting (FGM) was attended by representatives from SiVEST, Zitholele, BioTherm Energy and a local landowner. Apologies were given for Mr. Danie Bernhard who was not able to attend the meeting. A copy of the Attendance Record is attached as Annexure A.

3 PURPOSE OF THE MEETING

Nicolene Venter informed the attendees that the purpose of the FGM was to:

- To provide an overview of the proposed project;
- Provide an opportunity to raise comments and/or concerns regarding the proposed project;
- To provide feedback on the environmental findings as in the Draft Scoping Report; and
- To record comments, issues and concerns raised.

4 PROJECT CONTEXT AND OVERVIEW

Lynsey Rimbault presented an overview of the proposed project explaining the background to the project, what the project would entail and the current status of the EIA process.

Refer to Annexure B for a copy of the presentation.

5 DISCUSSION SESSION AND QUESTIONS

Please refer to Annexure C for the discussion session.

6 CLOSURE AND WAY FORWARD

Nicolene Venter closed the meeting at approximately 10h00. She informed the attendees that the FGM minutes, presentation, and attendance record would be forwarded to everyone who attended the meeting and to those who submitted apologies.

Annexure A

ATTENDANCE RECORD

Landowner Focus Group Meeting Attendance Register

Mr/Ms	Last Name	First Name	Position	Company
Ms	Mistry	Chetna	Analyst	BioTherm Energy
Mr	Rudolph	Gerrie	Landowner	Landowner
Ms	Richardson	Irene	Environmental Manager	BioTherm Energy
Mr	Isaacs	Jermaine	Construction Manager	BioTherm Energy
Ms	Rimbault	Lynsey	Environmental Consultant	SIVEST
Ms	Venter	Nicolene	Public Participation Practitioner	Zitholele

Annexure B

COPY OF PRESENTATION

ENVIRONMENTAL IMPACT ASSESSMENT FOR THE PROPOSED CONSTRUCTION OF THE THREE HELENA 75MW SOLAR PHOTOVOLTAIC (PV) ENERGY FACILITIES NEAR COPPERTON, NORTHERN CAPE PROVINCE: DRAFT SCOPING REPORT

DEA Reference Number:
 HELENA SOLAR 1: 14/12/16/13/3/2/165
 HELENA SOLAR 2: 14/12/16/13/3/2/166
 HELENA SOLAR 3: 14/12/16/13/3/2/167

A PROFESSIONAL TEAM DELIVERING CREATIVE PROJECT SOLUTIONS



Consulting Engineers • Project Managers • Environmental Consultants • Town and Regional Planners

LANDOWNER PUBLIC MEETING

PRESENTATION DATE: 22 May 2015

1

AGENDA



- Welcome, introduction and apologies
- Purpose and conduct of meeting
- Background to the proposed development
- Environmental process followed and desktop findings
- BioTherm Economic Development Strategy
- Discussion session
- Closure

2

PURPOSE OF MEETING



- To provide an overview of the proposed project
- To provide feedback on the desktop findings as documented in the DSR
- Provide an opportunity to raise comments and/or concerns regarding the proposed project
- To record comments, issues and concerns raised

3

PROJECT OVERVIEW



4

PROJECT OVERVIEW



- **What does the proposed development entail?**
 - Construction of three PV energy facilities, each with a maximum generation capacity of 75MW
 - Construction of associated infrastructure
 - New power lines from the PV energy facilities to the Eskom grid
 - New substations
 - Access road upgrades
 - Construction laydown areas
 - Admin and warehouse buildings
- **Why is the project being proposed?**
 - To generate electricity to feed into the national grid
 - Promote use of renewable energy
 - To help meet future energy consumption requirements

5

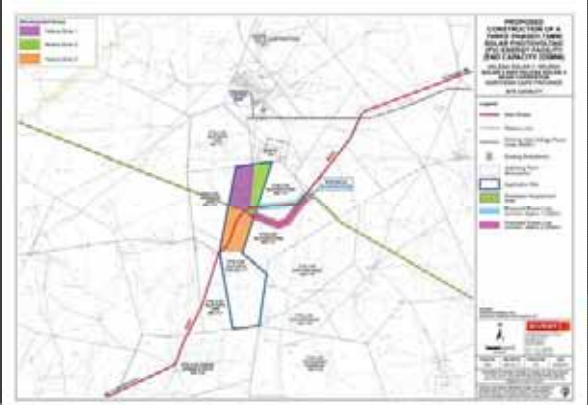
6

PROJECT OVERVIEW

- Who is the independent EAP?
 - SiVEST SA
- Why undertake an EIA?
 - Legal requirement
 - Consider environmental impacts and mitigation measures
 - Provide stakeholders/I&APs the opportunity to participate
- Who is the applicant?
 - BioTherm Energy
- Who is the decision-making authority?
 - Department of Environmental Affairs (DEA)

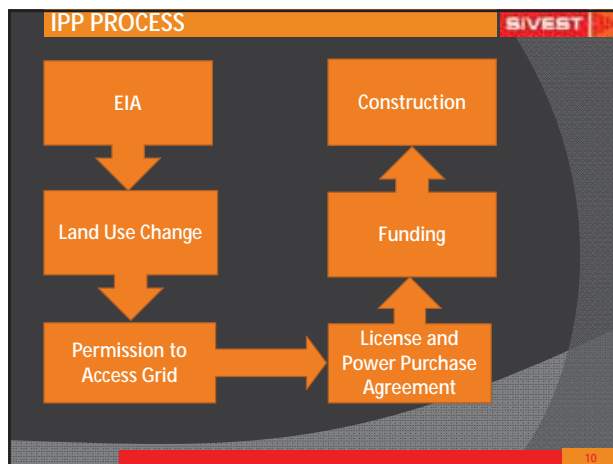
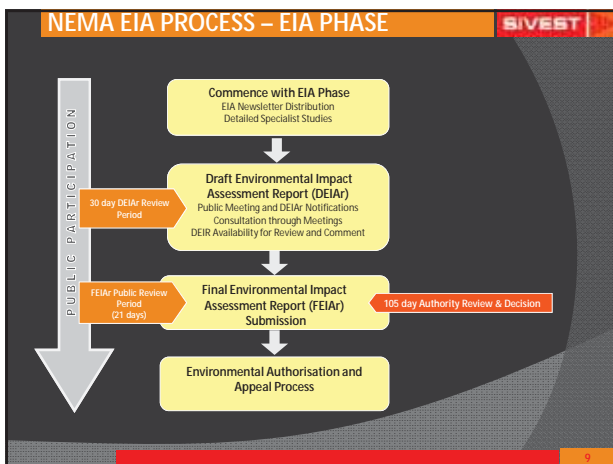
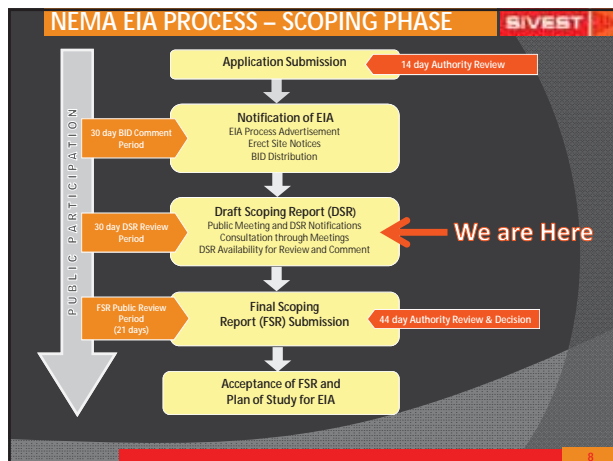

DESKTOP ENVIRONMENTAL FINDINGS

DESKTOP FINDINGS

- Scoping phase underway
 - Issues based, desk-top investigation
 - Identify potential issues for further investigated in the EIA phase
- Environmental aspects being assessed
 - Biodiversity (flora and fauna)
 - Avifauna
 - Surface Water
 - Soil and Agricultural Potential
 - Visual
 - Heritage
 - Socio-economic

DESKTOP FINDINGS **BIVEST**

Biodiversity Assessment

- The project is unlikely to have highly significant impacts on the ecological receiving environment.
- Impacts that will occur can be controlled and reduced to low significance.
- The seriousness of many of these impacts can be determined during the field investigation of the site. Some impacts may require permits to be issued.



13

DESKTOP FINDINGS **BIVEST**

Avifaunal Assessment

- With over a quarter of all southern African endemics or near endemics potentially occur in the study area, the study area as a whole should be regarded as moderately sensitive from an avifaunal perspective.
- Potential high sensitive, no-go areas were identified, i.e. surface water (water troughs and dams) and high voltage lines, as both these micro-habitats are potential focal points of bird activity.
 - Water troughs may be removed and therefore declassified
 - High voltage lines included as a precaution – buffers will be removed if there are no nests present



14

DESKTOP FINDINGS **BIVEST**

Surface Water Assessment

- Database findings revealed that two natural depression wetlands, and two non-perennial rivers are located within the study area.
- Desktop findings reveal:
 - Four depression wetlands; and
 - Two unnamed, non-perennial rivers.



15

DESKTOP FINDINGS **BIVEST**

Soils and Agricultural Assessment

- Virtually all of the study area comprises shallow, calcareous soils with rock.
- Coupled with these shallow soils, the very low rainfall in the area means that the only means of cultivation would be by irrigation and the Google Earth image of the area shows absolutely no signs of any agricultural infrastructure and certainly none of irrigation.
- The climatic restrictions mean that this part of the Northern Cape is suited at best for grazing and here the grazing capacity is low, around 20 ha/large stock unit.
- Therefore the expected impact is low, as soils are shallow and climate is very unfavourable for cultivation.

16

DESKTOP FINDINGS **BIVEST**

Visual Impact Assessment

- The study area has a rural visual character with a low visual sensitivity.
- However, several solar energy facilities are proposed within relatively close proximity to the proposed PV plant, which will alter the visual character.
- The proposed PV plant development is likely to visually influence four farmsteads identified within the visual assessment zone, therefore these are regarded to be potentially sensitive visual receptor locations.
- The sensitivity of the receptor locations will need to be confirmed through further assessment in the next phase of the study.



17

DESKTOP FINDINGS **BIVEST**

Heritage Assessment

- The possibility of archaeological finds have been identified as being high.
- The palaeontological potential of the area has been confirmed as being low.
- As seen from the archival in the heritage scoping report, the possibility of historical finds has been identified.
- Thus further fieldwork is required to develop a comprehensive Heritage Management Plan.



18

DESKTOP FINDINGS BIVEST

- **Socio-economic Assessment**
 - The national, provincial, and to some extent local government prioritise the development of renewable energy projects.
 - However, these developments should not jeopardise the growth of the other sectors, especially agriculture which is considered to be an economic driver in the local area.
 - The economy is in dire need for investment that would:
 - Diversify its economic base
 - Improve standards of living among local households through the increased income levels and access to improved municipal services
 - The proposed project is therefore likely to create a positive impact on the local economic development and the socio-economic environment in the municipality in general.

19

EIA PHASE STUDIES BIVEST

- Detailed studies to be undertaken in the EIA phase:
 - Biodiversity (flora and fauna)
 - Avifauna
 - Surface Water
 - Soil and Agricultural Potential
 - Visual
 - Heritage
 - Socio-economic

20

EIA PHASE STUDIES BIVEST

- **Issues to be addressed**
 - Undertake detailed fieldwork
 - Verify desktop findings
 - Rate the significance of impacts
 - Comparatively assess on site alternatives
 - Determine mitigation measures
 - Compile Environmental Management Programme

21

PUBLIC PARTICIPATION

22

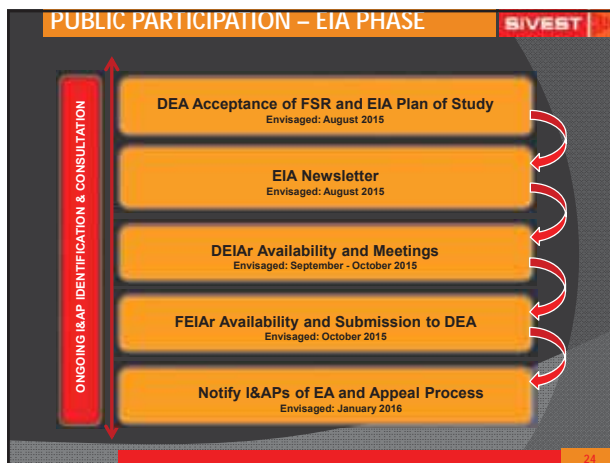



Economic Development



Private and Confidential

Economic Development 7/7/2015



26 Our Mission

- To drive sustainable change through the achievement of the following objectives:
 - Creation of meaningful and permanent employment;
 - Development of a robust renewable energy industry that supports local products and services and promotes sustainable growth;
 - Socio-economic development initiatives; and
 - Enterprise development initiatives

"What counts in life is not the mere fact that we have lived. It is what difference we have made to the lives of others that will determine the significance of the life we lead."
Nelson Rolihlahla Mandela

Economic Development 7/7/2015



27 Economic Development Pillars supported



- The initiatives we support focus on the following societal foundations:
 - Education
 - Healthcare
 - Sustainable Rural Development
 - Economic Empowerment of Women

Economic Development 7/7/2015



28 Implementation Strategy

- The steps taken, when formulating an ED strategy, consist of:
 - Analysis of existing local economic and social environment, including the regulatory and cultural elements
 - Needs assessment through engagement with relevant stakeholders such as:
 - Local and/ or national government
 - Communities directly impacted by project sites
 - Identification of crucial/ fundamental economic issues
 - Defining desired quantitative and qualitative outcomes, based on analysis and engagement
 - Identification of potential barriers and resources that may affect implementation
 - Quantification of resources required for implementation

Economic Development 7/7/2015



29 Implementation Strategy (Cont'd)

- Development of an action plan, including elements such as:
 - Work Task
 - Budget Required
 - Funding Source
 - Responsible Party
 - Completion Date
 - Progress Measurement Tool
- Monitoring, evaluation and update of strategy, if and when necessary



Economic Development 7/7/2015



30 Track Record

- Examples of initiatives implemented in South Africa include:
 - The upgrade of teaching equipment at a primary school in the Northern Cape, South Africa;
 - The provision of critical medical equipment to the local clinics and hospitals within various communities of the Northern Cape and Western Cape, South Africa;
 - The electrification of an Early Childhood Development (ECD) Centre in the Northern Cape, South Africa;
 - Infrastructural upgrades at an old age home in the Western Cape, South Africa, thus allowing them to qualify for better grant funding and accreditation;
 - Sponsorship of a "woman abuse awareness campaign" run by the South African Police Services in the Northern Cape, South Africa;

Economic Development 7/7/2015

Eidmann Living

31 Track Record (Cont'd)

- Supply of infantile mattresses to an ECD Centre in the Western Cape, South Africa;
- Provision of daily consumables to a disadvantage teenager diagnosed with Spina Bifida in the Western Cape, South Africa; and
- Sponsorship of a primary and high school principal to attend the Principal's Academy within the Western Cape, South Africa



Economic Development 3/7/2015

SIVEST

DISCUSSION

32

SIVEST

CONTACT DETAILS

SIVEST Environmental Division
 PO Box 2921
 Rivonia
 2128

Andrea Gibb / Lynsey Rimbault
 Phone: (011) 798 0600
 Fax: (011) 803 7272
 E-mail: andrag@sivest.co.za / lynsey@sivest.co.za
 Website: www.sivest.co.za

33

SIVEST

WAY FORWARD

	2015							2016
	June	July	Aug	Sep	Oct	Nov	Dec	Jan
End of DSR comment period	☀							
Submission of FSR to DEA		☀						
DEA decision on FSR			☀					
Distribution of EIA Newsletter			☀					
DEIAr Comment period				☀	☀			
Hold Meetings (FGM and PM)				☀				
Submission of FEIAr to DEA					☀			
DEA Decision								☀

34

Annexure C

DISCUSSION DOCUMENT

**ENVIRONMENTAL IMPACT ASSESSMENT (EIA) AND ENVIRONMENTAL
MANAGEMENT PROGRAMME (EMPr) FOR THE PROPOSED DEVELOPMENT OF
THREE 75MW SOLAR PHOTOVOLTAIC (PV) ENERGY FACILITIES NEAR
COPPERTON, NORTHERN CAPE PROVINCE**

HELENA SOLAR 1: DEA Ref No: 14/12/16/3/3/2/765

HELENA SOLAR 2: DEA Ref No: 14/12/16/3/3/2/766

HELENA SOLAR 3: DEA Ref No: 14/12/16/3/3/2/767

**FINAL DISCUSSION DOCUMENT
FOCUS GROUP MEETING: Landowners**

letznietz Guest House, Copperton

Friday, 22 May 2015 at 09h00

TABLE OF CONTENTS

1.	Agricultural Potential Related Comments/Issues	1
2.	Biodiversity Related Comments/Issues	1
3.	Socio-Economic Related Comments/Issues	1
4.	Water Related Comments/Issues.....	2
5.	EIA Process Related Comments/Issues.....	2
6.	Project Related Comments/Issues	3
7.	Communication Related Comments/Issues	3
8.	General Comments/Issues	3

Comments / concerns / issues have been categorised according to environmental impact and thereafter according to SURNAME.

The comments / concerns / issues captured are not verbatim, but a summary.

ABBREVIATIONS:

DEA	Department of Environmental Affairs	DoE	Department of Energy
DWS	Department of Water and Sanitation	EA	Environmental Authorisation
EAP	Environmental Assessment Practitioner	EMPr	Environmental Management Programme
PP	Public Participation	REIPPPP	Renewable Energy Independent Power Producer Procurement Programme
SKA	Square Kilometre Array		

Issue/Comment	Raised By & When	Response
1. Agricultural Potential Related Comments/Issues		
It was enquired as to what the main agricultural activity on the proposed site is.	VENTER, Nicolene PP Practitioner Zitholele Consulting	It is mainly sheep farming and the land is utilised for grazing. Gerrie Rudolph, Landowner: Farm Klipgats Pan
2. Biodiversity Related Comments/Issues		
<p>The project team was informed that once the natural habitat i.e. Karoo Bush (Karoo Bossie) is removed, it is not able to re-establish itself before grass takes over.</p> <p>It was asked whether vegetation will be cleared for the access road and recommended that the minimum amount of clearing is done.</p> <p>Biodiversity is a great concern.</p>	RUDOLPH, Gerrie Landowner Farm: Klipgatspan	<p>Vegetation will be cleared only for the panel footprints and the access road.</p> <p>Jermaine Isaacs, Construction Manager, BioTherm Energy</p> <p>The concern regarding possible negative impact on the biodiversity on the site will be forwarded to the biodiversity specialists to address in the impact phase.</p> <p>Nicolene Venter, PP Practitioner, Zitholele Consulting</p>
3. Socio-Economic Related Comments/Issues		
It was enquired, for clarification purposes, whether there are any asbestos deposits on the site that the landowner is aware of.	ISAACS, Jermaine Construction Manager BioTherm Energy	To his knowledge there is no asbestos deposits on his property and copper was the main mineral mined in the area. Gerrie Rudolph, Landowner: Klipgatspan
It was enquired as to how many seasonal workers are there on the farm.		Due to the nature of the farming activity, very few. Gerrie Rudolph, Landowner: Klipgatspan
Mr Rudolph asked what the financial investment of this proposed project would be, i.e. how much will it cost to be constructed.	RUDOLPH, Gerrie Landowner Farm: Klipgatspan	<p>The exact figures are not available at this stage and will only be determined later in the process.</p> <p>Irene Bezuidenhout, Environmental Manager, BioTherm Energy</p> <p>Post-meeting note: A typical 75MW PV Facility would cost approximately R1.5 billion.</p> <p>Irene Bezuidenhout, Environmental Manager, BioTherm Energy</p>

<p>It was enquired as to how many construction workers will be appointed during the construction and maintenance phases of the proposed project.</p>	<p>RUDOLPH, Gerrie Landowner Farm: Klipgatspan</p>	<p>These numbers are not yet available and will only be determined later in the process. More people will be employed during construction than operation. Irene Bezuidenhout, Environmental Manager, BioTherm Energy</p> <p>Post-meeting note: It is estimated that there will be approximately 129 skilled and unskilled employees during construction and 43 skilled and unskilled employees during operation. Irene Bezuidenhout, Environmental Manager, BioTherm Energy</p>
<p>4. Water Related Comments/Issues</p>		
<p>The project team was informed that the water in the area is very brackish and this could impact the efficiency of the panels.</p>	<p>RUDOLPH, Gerrie Landowner Farm: Klipgatspan</p>	<p>The high lime content in the water is a concern to BioTherm and before any cleaning method is decided upon, the water will be tested to assess the quality. Additionally, BioTherm is investigating dry cleaning methods. Jermaine Isaacs, Construction Manager, BioTherm Energy</p>
<p>It would be a preference if water could be trucked in from Prieska.</p>		<p>Preference has been acknowledged and will be put forward to the team for consideration. Irene Bezuidenhout, Environmental Manager, BioTherm Energy</p>
<p>It was asked whether herbicide will be used especially around the fences and the footprint of the panels.</p>		<p>Environmental specialists are often not in favour of using herbicides in preference to manual clearing. However BioTherm would consider herbicide if not prohibited in the EMPr as manual clearing has some drawbacks. Irene Bezuidenhout, Environmental Manager, BioTherm Energy</p>
<p>5. EIA Process Related Comments/Issues</p>		
<p>It was asked whether SiVEST deals with a specific person at the Department of Environmental Affairs (DEA) regarding this proposed project.</p>	<p>RUDOLPH, Gerrie Landowner Farm: Klipgatspan</p>	<p>There are a group of DEA Case Officers that are dealing with renewable energy applications. Lynsey Rimbault, Environmental Scientist, SiVEST</p>

		<p>Post-meeting note: Ms Mmatlala Rabothata has been appointed as the case officer for this proposed project. Lynsey Rimbault, Environmental Scientist, SiVEST</p>
6. Project Related Comments/Issues		
It was enquired whether the system to be used will be a fixed or tracking type.	RUDOLPH, Gerrie Landowner Farm: Klipgatspan	At this stage both technical options are being applied for. Irene Bezuidenhout, Environmental Manager, BioTherm Energy
It was asked how the panels will be cleaned i.e. manual pressure sprayer or a fixed sprayer on the panels.		Currently BioTherm is looking at a dry-cleaning method. Jermaine Isaacs, Construction Manager, BioTherm Energy
It was asked whether all three of the proposed projects will be constructed simultaneously.		If they have received Environmental Authorisations (EA) all three projects will be submitted to the Department of Energy (DoE) in the next Bidding round of the Renewable Energy Independent Power Producer Procurement Programme (REIPPPP), and the construction of the plants will depend on which projects are successful in the bidding process. Irene Bezuidenhout, Environmental Manager, BioTherm Energy
It was asked whether the Square Kilometre Array (SKA) had submitted their approval for this proposed project.		The SKA was provided with the Scoping Report and given an opportunity to comment on the project. It is likely that they will request specific studies to be done during the EIA phase to determine potential impacts of the project on the SKA. Irene Bezuidenhout, Environmental Manager, BioTherm Energy
7. Communication Related Comments/Issues		
It was requested that the Draft Scoping Report, including the surface water map, be provided on a CD due to slow internet connection on the farm.	RUDOLPH, Gerrie Landowner Farm:Klipgatspan	The request was acknowledged and SiVEST posted the CD on the 29 th of May 2015. Lynsey Rimbault, Environmental Scientist, SiVEST
8. General Comments/Issues		

<p>Dissatisfaction was expressed regarding the current solar development taking place in the area as no dust suppression is being done for the water trucks (minimum of two trucks daily) supplying water to the construction site.</p> <p>It was also enquired as to who can be contacted to report the matter and also to enquire whether the project applied for and received a Water Use License.</p>	<p>RUDOLPH, Gerrie Landowner Farm:Klipgatspan</p>	<p>Water must be obtained from a legal source and the quantity envisaged to be used must be recorded.</p> <p><i>Irene Bezuidenhout, Environmental Manager, BioTherm Energy</i></p> <p>The contact details of the Green Scorpions, for compliance with the EA, and that of the Department of Water and Sanitation (DWS) for the Water Use License enquiry, will be forwarded.</p> <p><i>Nicolene Venter, PP Practitioner, Zitholele Consulting</i></p> <p><u>Post-meeting note:</u> The requested details were e-mailed on 27 May 2015</p>
---	---	--



**ENVIRONMENTAL IMPACT
ASSESSMENT (EIA) AND
ENVIRONMENTAL MANAGEMENT
PROGRAMME (EMPr) FOR THE
PROPOSED DEVELOPMENT OF THREE
75MW SOLAR PHOTOVOLTAIC (PV)
ENERGY FACILITIES NEAR
COPPERTON, NORTHERN CAPE
PROVINCE**

**FINAL MINUTES OF THE
FOCUS GROUP MEETING**

Municipal Officials

Held on
Thursday, 21 May 2015 at 12h00
SiyaThemba Local Municipality's Chambers, Victoria
Street, Prieska

Northern Cape Province

SiVEST Environmental (Pty) Ltd

Contact: Andrea Gibb / Lynsey Rimbault

Address: PO Box 2921
51 Wessels Road
Rivonia 2128

Tel: 011 798 0600

Fax: 011 803 7272

E-mail: andreag@sivest.co.za
lynseyr@sivest.co.za

Final Minutes prepared by:
Lynsey Rimbault

TABLE OF CONTENTS

1	WELCOME, INTRODUCTIONS.....	1
2	MEETING ATTENDEES	1
3	PURPOSE OF THE MEETING	1
4	PROJECT CONTEXT AND OVERVIEW	1
5	DISCUSSION SESSION AND QUESTIONS.....	1
6	CLOSURE AND WAY FORWARD.....	2

FOCUS GROUP MEETING

Venue: SiyaThemba Local Municipality's Chambers, Victoria Street, Prieska

Date: Thursday, 21 May 2015

Time: 12h00 – 13h00

1 WELCOME, INTRODUCTIONS

Nicolene Venter welcomed everyone who attended the Focus Group Meeting (FGM). She introduced the representatives from SiVEST, Zitholele and BioTherm Energy at the meeting, noting that SiVEST is the independent Environmental Assessment Practitioner (EAP) undertaking the Environmental Impact Assessment (EIA) process.

2 MEETING ATTENDEES

The Focus Group Meeting (FGM) was attended by representatives from SiVEST, Zitholele, BioTherm Energy and local business and municipal representatives. Apologies were given for the Municipal LED Manager, Mr. Jakob Basson, and the Assistant to the Municipal Manager, Ms. Beatrice Mondzinger. A copy of the Attendance Record is attached as Annexure A.

3 PURPOSE OF THE MEETING

Nicolene Venter informed the attendees that the purpose of the FGM was to:

- To provide an overview of the proposed project;
- Provide an opportunity to raise comments and/or concerns regarding the proposed project;
- To provide feedback on the environmental findings as in the Draft Scoping Report; and
- To record comments, issues and concerns raised.

4 PROJECT CONTEXT AND OVERVIEW

Lynsey Rimbault presented an overview of the proposed project explaining the background to the project, what the project would entail and the current status of the EIA process. Refer to Annexure B for further information.

Refer to Annexure B for a copy of the presentation.

5 DISCUSSION SESSION AND QUESTIONS

Please refer to Annexure C for further the discussion session.

6 CLOSURE AND WAY FORWARD

Nicolene Venter closed the meeting at approximately 13h00. She informed the attendees that the FGM minutes, presentation, and attendance record would be forwarded to everyone who attended the meeting and to those who submitted apologies.

Annexure A

ATTENDANCE RECORD

Municipality Focus Group Meeting Attendance Register

Mr/Ms	Last Name	First Name	Position	Company
Mr	Barnard	Zak	Managing Director	Electrotech Prieska
Mr	Isaacs	Jermaine	Construction Manager	BioTherm Energy
Ms	Mdllovama	Sivemah	I. Officer	Deptment of Home Affairs
Ms	Mistry	Chetna	Analyst	BioTherm Energy
Mr	Nel	AG	MD/CEO	Servigraphs2 CC t/a Lnack Trading
Ms	Richardson	Irene	Environmental Manager	BioTherm Energy
Ms	Rimbault	Lynsey	Environmental Consultant	SiVEST
Ms	Venter	Nicolene	Public Participation Practitioner	Zitholele

Annexure B

COPY OF PRESENTATION

ENVIRONMENTAL IMPACT ASSESSMENT FOR THE PROPOSED CONSTRUCTION OF THE THREE HELENA 75MW SOLAR PHOTOVOLTAIC (PV) ENERGY FACILITIES NEAR COPPERTON, NORTHERN CAPE PROVINCE: DRAFT SCOPING REPORT

DEA Reference Number:
 HELENA SOLAR 1: 14/12/16/13/3/2/165
 HELENA SOLAR 2: 14/12/16/13/3/2/166
 HELENA SOLAR 3: 14/12/16/13/3/2/167

A PROFESSIONAL TEAM DELIVERING CREATIVE PROJECT SOLUTIONS

SIVEST

Consulting Engineers • Project Managers • Environmental Consultants • Town and Regional Planners

MUNICIPALITY PUBLIC MEETING

PRESENTATION DATE: 21 May 2015

1

AGENDA

- Welcome, introduction and apologies
- Purpose and conduct of meeting
- Background to the proposed development
- Environmental process followed and desktop findings
- BioTherm Economic Development Strategy
- Discussion session
- Closure

2

PURPOSE OF MEETING

- To provide an overview of the proposed project
- To provide feedback on the desktop findings as documented in the DSR
- Provide an opportunity to raise comments and/or concerns regarding the proposed project
- To record comments, issues and concerns raised

3

PROJECT OVERVIEW

4

PROJECT OVERVIEW

- What does the proposed development entail?
 - Construction of three PV energy facilities, each with a maximum generation capacity of 75MW
 - Construction of associated infrastructure
 - New power lines from the PV energy facilities to the Eskom grid
 - New substations
 - Access road upgrades
 - Construction laydown areas
 - Admin and warehouse buildings
- Why is the project being proposed?
 - To generate electricity to feed into the national grid
 - Promote use of renewable energy
 - To help meet future energy consumption requirements

5

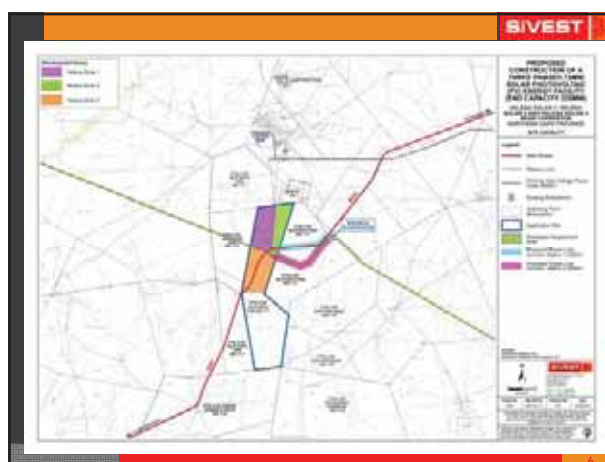

PROJECT OVERVIEW

- Who is the independent EAP?
 - SiVEST SA
- Why undertake an EIA?
 - Legal requirement
 - Consider environmental impacts and mitigation measures
 - Provide stakeholders/I&APs the opportunity to participate
- Who is the applicant?
 - BioTherm Energy
- Who is the decision-making authority?
 - Department of Environmental Affairs (DEA)

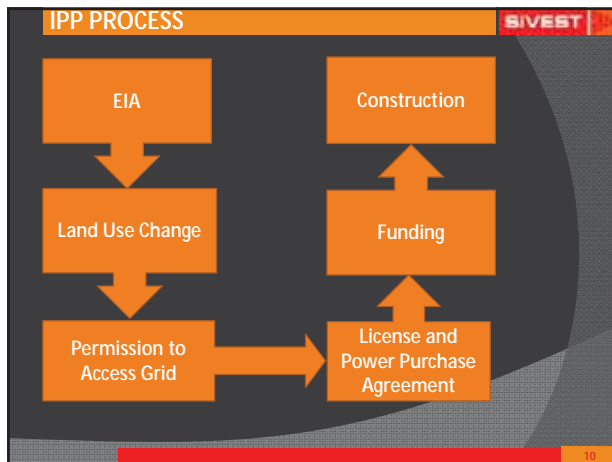
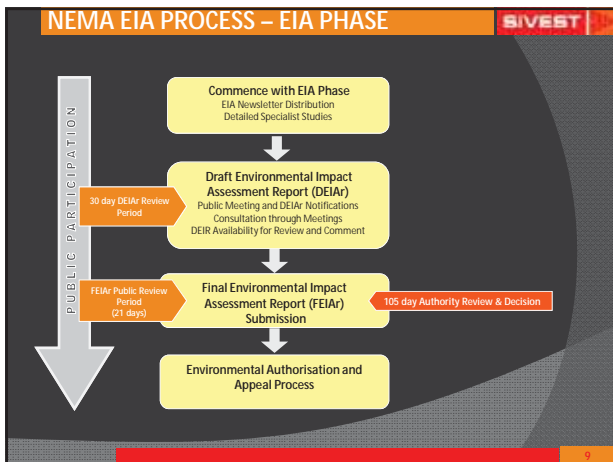
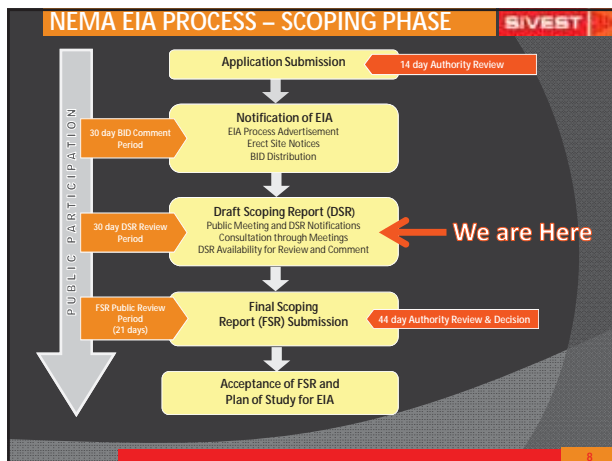

DESKTOP ENVIRONMENTAL FINDINGS

DESKTOP FINDINGS

- Scoping phase underway
 - Issues based, desk-top investigation
 - Identify potential issues for further investigated in the EIA phase
- Environmental aspects being assessed
 - Biodiversity (flora and fauna)
 - Avifauna
 - Surface Water
 - Soil and Agricultural Potential
 - Visual
 - Heritage
 - Socio-economic

DESKTOP FINDINGS **BIVEST**

Biodiversity Assessment

- The project is unlikely to have highly significant impacts on the ecological receiving environment.
- Impacts that will occur can be controlled and reduced to low significance.
- The seriousness of many of these impacts can be determined during the field investigation of the site. Some impacts may require permits to be issued.



13

DESKTOP FINDINGS **BIVEST**

Avifaunal Assessment

- With over a quarter of all southern African endemics or near endemics potentially occur in the study area, the study area as a whole should be regarded as moderately sensitive from an avifaunal perspective.
- Potential high sensitive, no-go areas were identified, i.e. surface water (water troughs and dams) and high voltage lines, as both these micro-habitats are potential focal points of bird activity.
 - Water troughs may be removed and therefore declassified
 - High voltage lines included as a precaution – buffers will be removed if there are no nests present



14

DESKTOP FINDINGS **BIVEST**

Surface Water Assessment

- Database findings revealed that two natural depression wetlands, and two non-perennial rivers are located within the study area.
- Desktop findings reveal:
 - Four depression wetlands; and
 - Two unnamed, non-perennial rivers.



15

DESKTOP FINDINGS **BIVEST**

Soils and Agricultural Assessment

- Virtually all of the study area comprises shallow, calcareous soils with rock.
- Coupled with these shallow soils, the very low rainfall in the area means that the only means of cultivation would be by irrigation and the Google Earth image of the area shows absolutely no signs of any agricultural infrastructure and certainly none of irrigation.
- The climatic restrictions mean that this part of the Northern Cape is suited at best for grazing and here the grazing capacity is low, around 20 ha/large stock unit.
- Therefore the expected impact is low, as soils are shallow and climate is very unfavourable for cultivation.

16

DESKTOP FINDINGS **BIVEST**

Visual Impact Assessment

- The study area has a rural visual character with a low visual sensitivity.
- However, several solar energy facilities are proposed within relatively close proximity to the proposed PV plant, which will alter the visual character.
- The proposed PV plant development is likely to visually influence four farmsteads identified within the visual assessment zone, therefore these are regarded to be potentially sensitive visual receptor locations.
- The sensitivity of the receptor locations will need to be confirmed through further assessment in the next phase of the study.



17

DESKTOP FINDINGS **BIVEST**

Heritage Assessment

- The possibility of archaeological finds have been identified as being high.
- The palaeontological potential of the area has been confirmed as being low.
- As seen from the archival in the heritage scoping report, the possibility of historical finds has been identified.
- Thus further fieldwork is required to develop a comprehensive Heritage Management Plan.



18

DESKTOP FINDINGS BIVEST

- **Socio-economic Assessment**
 - The national, provincial, and to some extent local government prioritise the development of renewable energy projects.
 - However, these developments should not jeopardise the growth of the other sectors, especially agriculture which is considered to be an economic driver in the local area.
 - The economy is in dire need for investment that would:
 - Diversify its economic base
 - Improve standards of living among local households through the increased income levels and access to improved municipal services
 - The proposed project is therefore likely to create a positive impact on the local economic development and the socio-economic environment in the municipality in general.

19

EIA PHASE STUDIES BIVEST

- Detailed studies to be undertaken in the EIA phase:
 - Biodiversity (flora and fauna)
 - Avifauna
 - Surface Water
 - Soil and Agricultural Potential
 - Visual
 - Heritage
 - Socio-economic

20

EIA PHASE STUDIES BIVEST

- **Issues to be addressed**
 - Undertake detailed fieldwork
 - Verify desktop findings
 - Rate the significance of impacts
 - Comparatively assess on site alternatives
 - Determine mitigation measures
 - Compile Environmental Management Programme

21

PUBLIC PARTICIPATION

22

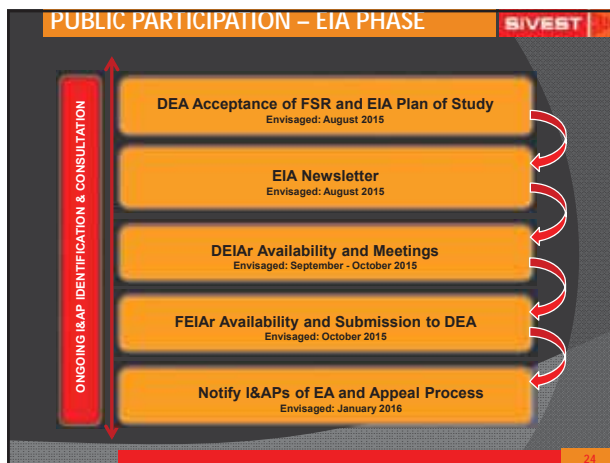



Economic Development



Private and Confidential

Economic Development 7/7/2015



26 Our Mission

- To drive sustainable change through the achievement of the following objectives:
 - Creation of meaningful and permanent employment;
 - Development of a robust renewable energy industry that supports local products and services and promotes sustainable growth;
 - Socio-economic development initiatives; and
 - Enterprise development initiatives

"What counts in life is not the mere fact that we have lived. It is what difference we have made to the lives of others that will determine the significance of the life we lead."
Nelson Rolihlahla Mandela

Economic Development 7/7/2015



27 Economic Development Pillars supported



- The initiatives we support focus on the following societal foundations:
 - Education
 - Healthcare
 - Sustainable Rural Development
 - Economic Empowerment of Women

Economic Development 7/7/2015



28 Implementation Strategy

- The steps taken, when formulating an ED strategy, consist of:
 - Analysis of existing local economic and social environment, including the regulatory and cultural elements
 - Needs assessment through engagement with relevant stakeholders such as:
 - Local and/ or national government
 - Communities directly impacted by project sites
 - Identification of crucial/ fundamental economic issues
 - Defining desired quantitative and qualitative outcomes, based on analysis and engagement
 - Identification of potential barriers and resources that may affect implementation
 - Quantification of resources required for implementation

Economic Development 7/7/2015



29 Implementation Strategy (Cont'd)

- Development of an action plan, including elements such as:
 - Work Task
 - Budget Required
 - Funding Source
 - Responsible Party
 - Completion Date
 - Progress Measurement Tool
- Monitoring, evaluation and update of strategy, if and when necessary



Economic Development 7/7/2015



30 Track Record

- Examples of initiatives implemented in South Africa include:
 - The upgrade of teaching equipment at a primary school in the Northern Cape, South Africa;
 - The provision of critical medical equipment to the local clinics and hospitals within various communities of the Northern Cape and Western Cape, South Africa;
 - The electrification of an Early Childhood Development (ECD) Centre in the Northern Cape, South Africa;
 - Infrastructural upgrades at an old age home in the Western Cape, South Africa, thus allowing them to qualify for better grant funding and accreditation;
 - Sponsorship of a "woman abuse awareness campaign" run by the South African Police Services in the Northern Cape, South Africa;

Economic Development 7/7/2015

31 Track Record (Cont'd)



- Supply of infantile mattresses to an ECD Centre in the Western Cape, South Africa;
- Provision of daily consumables to a disadvantage teenager diagnosed with Spina Bifida in the Western Cape, South Africa; and
- Sponsorship of a primary and high school principal to attend the Principal's Academy within the Western Cape, South Africa



Economic Development 3/7/2015

SIVEST

DISCUSSION

32

CONTACT DETAILS

SIVEST

SIVEST Environmental Division
 PO Box 2921
 Rivonia
 2128

Andrea Gibb / Lynsey Rimbault
 Phone: (011) 798 0600
 Fax: (011) 803 7272
 E-mail: andrag@sivest.co.za / lynsey@sivest.co.za
 Website: www.sivest.co.za

33

WAY FORWARD

SIVEST

	2015							2016
	June	July	Aug	Sep	Oct	Nov	Dec	Jan
End of DSR comment period	☀							
Submission of FSR to DEA		☀						
DEA decision on FSR			☀					
Distribution of EIA Newsletter			☀					
DEIAr Comment period				☀	☀			
Hold Meetings (FGM and PM)				☀				
Submission of FEIAr to DEA					☀			
DEA Decision								☀

34

Annexure C

DISCUSSION DOCUMENT

**ENVIRONMENTAL IMPACT ASSESSMENT (EIA) AND ENVIRONMENTAL
MANAGEMENT PROGRAMME (EMPr) FOR THE PROPOSED DEVELOPMENT OF
THREE 75MW SOLAR PHOTOVOLTAIC (PV) ENERGY FACILITIES NEAR
COPPERTON, NORTHERN CAPE PROVINCE**

HELENA SOLAR 1: DEA Ref No: 14/12/16/3/3/2/765

HELENA SOLAR 2: DEA Ref No: 14/12/16/3/3/2/766

HELENA SOLAR 3: DEA Ref No: 14/12/16/3/3/2/767

**FINAL DISCUSSION DOCUMENT
FOCUS GROUP MEETING: SiyaThemba Local Municipality**

SiyaThemba Local Municipality's Chambers, Victoria Street, Prieska

Thursday, 21 May 2015 at 12h00

TABLE OF CONTENTS

1.	Socio-Economic Related Comments/Issues	1
2.	EIA Process Related Comments/Issues.....	2
3.	Project Related Comments/Issues	2

Comments / concerns / issues have been categorised according to environmental impact and thereafter according to SURNAME.

The comments / concerns / issues captured are not verbatim, but a summary

ABBREVIATIONS:

CEO	Chief Executive Officer	EPC	Engineering, Procurement and Construction
SIA	Social Impact Assessment	MD	Managing Director
REIPPPP	Renewable Energy Independent Power Producer Procurement Programme		

Issue/Comment	Raised By	Response
1. Socio-Economic Related Comments/Issues		
<p>The team was informed that there are asbestos deposits around Prieska which have had detrimental impacts on the health of residents. Mr Nell enquired as to whether there is a possibility that there could be asbestos on the site that could be disturbed when construction starts, particularly when the wind is blowing.</p>	<p>NELL, Kevin MD & CEO: Servigraph 52 CC Member: Chamber of Commerce</p>	<p>The geotechnical studies still need to be conducted and these will determine whether asbestos is present or not. <i>Jermaine Isaacs, Construction Manager, BioTherm Energy</i></p> <p>The Socio-economic and Soils and Agricultural Potential Specialists will be informed of the potential for asbestos occurring in the Copperton area and if necessary will assess the potential impact of this in their reports. <i>Lynsey Rimbault, Environmental Consultant, SiVEST</i></p> <p><u>Post Meeting Note</u> The landowner of the proposed Helena projects has no knowledge of asbestos deposits on his property and he stated that copper was the main mineral mined in the Copperton area, not asbestos as was the case in Prieska. <i>Lynsey Rimbault, Environmental Consultant, SiVEST</i></p>
<p>Mr Nell requested that through the three Helena projects, BioTherm Energy assist the local service providers in fostering sustainable economic growth rather than a short term cash injection.</p>	<p>NELL, Kevin MD & CEO: Servigraph 52 CC Member: Chamber of Commerce</p>	<p>This comment will be put forward to BioTherm's Development Manager. <i>Irene Bezuidenhout, Environmental Manager, BioTherm Energy</i></p> <p><u>Post-meeting note:</u> The request has been noted by BioTherm's Development Manager. <i>Irene Bezuidenhout, Environmental Manager, BioTherm Energy</i></p>
<p>The project team was informed that Prieska has a 41% unemployment rate and the town would therefore appreciate any development that could alleviate this social constraint.</p>	<p>NELL, Kevin MD & CEO: Servigraph 52 CC Member: Chamber of Commerce</p>	<p>The SIA specialist identified this constraint and the impact will be addressed in detail during the impact phase. <i>Lynsey Rimbault, Environmental Consultant, SiVEST</i></p>

<p>It was enquired as to the requirements for the main contractor, because local businesses would consider forming a joint venture and tendering as the main contractor. They would also need to establish whether a group of local businesses can bid as an EPC.</p>	<p>BARNARD, Zak Managing Director: Electrotech Member: Chambers of Commerce</p>	<p>A document which will briefly outline the minimum requirements of contracting will be prepared and forwarded to the Chamber of Commerce. <i>Jermaine Isaacs, Construction Manager, BioTherm Energy</i></p>
<p>The project team was informed that with the number of renewable energy projects developed in the area the local business people (construction and other) have gained a lot of experience and believe that they are in a position to tender as main contractor and not as sub-contractors.</p> <p>It was stated that the local businesses and labour force available must not be down played as the knowledge and expertise base in Prieska is good.</p>	<p>BARNARD, Zak Managing Director: Electrotech Member: Chambers of Commerce</p>	<p>The information provided will be taken into consideration should the project receive environmental authorisation and the tender process commences. <i>Jermaine Isaacs, Construction Manager, BioTherm Energy</i></p>
<p>2. EIA Process Related Comments/Issues</p>		
<p>It was asked whether this EIA process has not been done before for other renewable energy projects in the area i.e. rehashing the same impacts and issues.</p>	<p>BARNARD, Zak Managing Director: Electrotech Member: Chambers of Commerce</p>	<p>Although cognisance is taken of other environmental studies done for other EIA projects in the same study area, this EIA, including the specialist studies, is site specific. <i>Lynsey Rimbault, Environmental Consultant, SiVEST</i></p> <p>It is important to note that specialist studies also assess, and where necessary address, cumulative impacts. <i>Nicolene Venter, PP Practitioner, Zitholele Consulting</i></p>
<p>3. Project Related Comments/Issues</p>		
<p>It was asked whether the three (3) projects would run concurrently.</p>	<p>BARNARD, Zak Managing Director: Electrotech Member: Chambers of Commerce</p>	<p>This has not been confirmed at this stage and would depend on various factors such whether all, two or one of the projects are selected as preferred bidders in the Renewable Energy Independent Power Producer Procurement Programme (REIPPPP). <i>Irene Bezuidenhout, Environmental Manager, BioTherm Energy</i></p>
<p>Prieska's business community was at a disadvantage with previous developments in the area as they were not provided with sufficient time to prepare for the tendering process.</p>	<p>NELL, Kevin MD & CEO: Servigraph 52 CC</p>	<p>BioTherm confirmed that they will notify the Prieska Chamber of Commerce before the EPC tender request appears in the newspapers.</p>

It was requested that BioTherm notify them timeously when the EPC tender will be placed.	Member: Chamber of Commerce	<i>Irene Bezuidenhout, Environmental Manager, BioTherm Energy</i>
--	-----------------------------	--

SiVEST Environmental (Pty) Ltd

Name: Nicolene Venter / Andrea Gibb
Address: P.O. Box 2921
51 Wessel Street
Rivonia 2128
Tel: 011 798 0600
Fax: 011 803 7272
E-mail: andreag@sivest.co.za

Proposed Development of Three 75 MW Photovoltaic Solar Power Facilities near Copperton

**(Helena Solar 1 – DEA Ref. No.: 14/12/16/3/3/2/765;
Helena Solar 2 – DEA Ref. No.: 14/12/16/3/3/2/766;
Helena Solar 3 – DEA Ref. No.: 14/12/16/3/3/2/767)**

SUMMARY NOTES OF PROJECT INFORMATION SESSION

**held on
Tuesday 24 February 2015
Klipgats Pan, Copperton**

Compiled by Nicolene Venter

Please send any comments to Nicolene Venter at the address provided.

TABLE OF CONTENTS

1	OPENING AND WELCOMING	3
2	PRESENT AT THE MEETING	3
3	PURPOSE OF THE MEETING	3
4	PROJECT OVERVIEW	3
5	DISCUSSIONS	3
6	CLOSURE	5

1 OPENING AND WELCOMING

Nicolene Venter, Zitholele Consulting, thanked the landowners present for their attendance at the notice, information and comment session for the proposed development of three 75 MW Photovoltaic (PV) Solar Power Facilities on the farm Klipgats Pan near Copperton.

For minuting purposes, the participants were requested to introduce themselves when they ask questions or make comments.

The issue of language was addressed and it was decided that the meeting would take place in Afrikaans.

2 PRESENT AT THE MEETING

A copy of the attendance record is attached in Annexure A.

The following landowners tendered their apologies:

- Danie & Jomima Bernard, Klipgats Pan;
- Albertha Kellerman, Groot Fourie's Kolk;
- Almarette Nieuwoudt, Springbok Poortje;
- Coenie & Adelle Viljoen, Mierdam;
- Anton van Heerden, Kaffirs Kolk; and
- Pilla Buis, Klipgatspan.

3 PURPOSE OF THE MEETING

Nicolene Venter explained the purpose of the meeting to those present, which included:

- giving an overview of the proposed project;
- affording those present the opportunity to gain clarity about the proposed project and to raise issues that could be submitted to the environmental specialists for investigation; and
- recording comments, issues and concerns that were raised during the meeting.

4 PROJECT OVERVIEW

Nicolene Venter gave a short overview of the reasons why the proposed project is necessary.

BioTherm Energy (Pty) Ltd (hereinafter referred to as BioTherm) proposed the construction of a three phase photovoltaic (PV) solar power facility with a total export capacity of 225 MW, near Copperton in the Northern Cape Province. The proposed project will comprise three PV solar power facilities with an export capacity of 75 MW each to be called Helena Solar 1, 2 and 3.

5 DISCUSSIONS

5.1 Mr Frans Ekkerd, Uitspan Pan, informed those present that the water quality in the area is brackish. Mulilo is expected to start with construction of the PV facility on the farm Uitspan Pan on 1 March 2015.

The question was which water source was being considered for cleaning the solar panels.

Nicolene Venter said that it is expected that recycled water would be used. This fact will be confirmed by the project team.

- 5.2 Mr Ekkerd asked whether the dirt road would be tarred to prevent dust deposits on the solar panels, which would increase the need to clean the panels with associated increased water usage.

Post Meeting Note: The developer will be notified of the comment by Mr Ekkerd and the issue of tarred versus dirt roads will be addressed during the EIA phase of the project.

- 5.3 Mr Ekkerd referred to a water pipeline being planned by Bloemwater from Prieska to Van Wyksvlei to address the water shortage in the area. The residents are currently unaware of this water pipeline being planned.

Post Meeting Note: The developer will be notified of the proposed water pipeline.

- 5.4 Mr Ekkerd mentioned that there is word of the upgrading of the Kronos Substation and asked whether the project team was aware of this.

Post Meeting Note: The project team was not aware of any potential upgrades to the Kronos Substation. The grid connection requirements will be established through consultation between the developer and Eskom during the EIA phase of the project and thereafter when the detailed designs are undertaken.

- 5.5 Johannes Human, Hoekplaas Boerdery, raised the following:

- a) Was the development planned for only the northern portion of the farm and no development on the southern portion?
- b) How will the safety aspect of especially the residents of the area be addressed by the specialist, mainly during the construction phase?
- c) How would the possibility of stock theft be addressed by the specialist, especially during the construction phase?
- d) The request is made that the biodiversity specialist should not disturb fauna and flora during the site visit.
- e) It is requested that landowners be informed timeously of when the specialists would undertake their site visits.

Post Meeting Note: The development is intended to take place on the northern half of Portion 3 of Klipgats Pan No 117. Socio-economic issues will be addressed as part of the Environmental Management Programme (EMPr) in the EIA phase of the project. The biodiversity specialist will be informed of Mr Human's request and will endeavour to minimise disturbance to fauna and flora in the project area. Landowners will be notified in advance when specialists intend to conduct field studies.

- 5.6 Mr Ekkerd asked what precautions would be taken to prevent or reduce the impact of dust on the adjacent homes.

Post Meeting Note: The issue of dust will be addressed during the EIA phase of the project. Dust suppression methods will be employed during construction, and if necessary during operation in accordance with the EMPr.

5.7 Mr Gerrie Rudolph asked what precautionary measures would be taken to prevent or reduce the impact of dust on their home since the re-establishment of the vegetation could take between 10 to 20 years.

Post Meeting Note: The issue of dust will be addressed during the EIA phase of the project. Dust suppression methods will be employed during construction, and if necessary during operation in accordance with the EMPr. The issue of re-establishing vegetation will be addressed by the biodiversity specialist during the EIA phase.

6 CLOSURE

Nicolene Venter thanked everybody for their presence and the valuable inputs given during the information session. She informed those present that feedback on their questions and concerns would be included in the Comment and Response Report, which would be included in the Draft Basic Assessment Report.

The meeting adjourned at 11h30.

ANNEXURE A

ATTENDANCE RECORD

Environmental Impact Assessment (EIA) for the Proposed Development of Three 75MW Solar Photovoltaic (PV) Energy Facilities Near Copperton, Northern Cape Province.

(DEA Ref No: 14/12/16/3/2/765), (DEA Ref No: 14/12/16/3/2/766), (DEA Ref No: 14/12/16/3/2/767)

Landowner/ Authority/ I&APs Notification

Tuesday, 24 February 2015

REGISTER



NAME & SURNAME	ORGANISATION	POSTAL ADDRESS	CONTACT DETAILS	SIGNATURE
GERRIE RUDOPH	PLAAS EIENAAR.	POSBUS 528 PRIESKA. 8940	Tel No: Fax No: Cell No: 082 960 2113 E-mail: GERRIERUDOPH@VODAMAIL.CO.ZA	
Johannes Human	Hoekplaas Bdy	Postbus 390 Prieska 8940	Tel No: Fax No: Cell No: 082 883 8330 E-mail: johanneshuman5@gmail.com	
FRANS EKICERD	LIFSPAN PAN	BUS 446 PRIESKA 8940	Tel No: Fax No: Cell No: 083 380 8427 E-mail:	

NAME & SURNAME	ORGANISATION	POSTAL ADDRESS	CONTACT DETAILS	SIGNATURE
J.J. Botter	Pleasencoes	Postbus 192 Pretoria 890	Tel No: Fax No: Cell No: 0827170439 E-mail:	
			Tel No: Fax No: Cell No: E-mail:	
			Tel No: Fax No: Cell No: E-mail:	
			Tel No: Fax No: Cell No: E-mail:	
			Tel No: Fax No: Cell No: E-mail:	



**ENVIRONMENTAL IMPACT
ASSESSMENT (EIA) AND
ENVIRONMENTAL MANAGEMENT
PROGRAMME (EMPr) FOR THE
PROPOSED DEVELOPMENT OF
THREE 75MW SOLAR PHOTOVOLTAIC
(PV) ENERGY FACILITIES NEAR
COPPERTON, NORTHERN CAPE
PROVINCE**

**FINAL MINUTES OF
PUBLIC MEETING**

Held on
Thursday, 21 May 2015 at 16h30
Omega Hall, Alwyn Street, Bonteheuwel, Prieska

Northern Cape Province

SiVEST Environmental (Pty) Ltd

Contact: Nicolene Venter/Lynsey Rimbault

Address: PO Box 2921
51 Wessels Road
Rivonia 2128

Tel: 011 798 0600

Fax: 011 803 7272

E-mail: nicolenev@zitholele.co.za

lynseyr@sivest.co.za

Final Minutes prepared by:

Lynsey Rimbault

TABLE OF CONTENTS

1	WELCOME, INTRODUCTIONS.....	2
2	MEETING ATTENDEES	2
3	PURPOSE OF THE MEETING	2
4	PROJECT CONTEXT AND OVERVIEW	2
5	DISCUSSION SESSION AND QUESTIONS	2
6	CLOSURE AND WAY FORWARD	2

PUBLIC MEETING

Venue: Omega Hall, Alwyn Street, Bonteheuwel, Prieska
Date: Thursday, 21 May 2015
Time: 16h30-17h30

1 WELCOME, INTRODUCTIONS

Nicolene Venter welcomed everyone who attended the Public Meeting (PM). She introduced the representatives from SiVEST, Zitholele and BioTherm Energy at the meeting, noting that SiVEST is the independent Environmental Assessment Practitioner (EAP) undertaking the Environmental Impact Assessment (EIA) process.

2 MEETING ATTENDEES

A copy of the Attendance Record is attached as Annexure A.

3 PURPOSE OF THE MEETING

Nicolene Venter informed the attendees that the purpose of the PM was to:

- To provide an overview of the proposed project;
- Provide an opportunity to raise comments and/or concerns regarding the proposed project;
- To provide feedback on the environmental findings as in the Draft Scoping Report; and
- To record comments, issues and concerns raised.

4 PROJECT CONTEXT AND OVERVIEW

Nicolene Venter presented an overview of the proposed project explaining the background to the project, what the project would entail and the current status of the EIA process.

Refer to Annexure B for a copy of the presentation.

5 DISCUSSION SESSION AND QUESTIONS

Please refer to Annexure C for further the discussion session.

6 CLOSURE AND WAY FORWARD

Nicolene Venter closed the meeting at 17h30 and further stated that this would not be the last opportunity afforded to them to provide comments. She informed the attendees that the PM minutes, presentation, and attendance record would be forwarded to everyone who attended the meeting and to those who submitted apologies.

Annexure A

ATTENDANCE RECORD

Public Meeting Attendance Register				
Mr/Ms	Last Name	First Name	Position	Company
Mr	-	Richard		
Mr	Adams	Nillaas	General Worker	
Mr	Adonis	Muldry (Webb)		
Ms	Ana-Miah	Kholiwe		
Mr	Andreas	Frank		Siyamthemba Municipality
Mr	Arries	Martin		
Mr	August	Ronald		
Mr	Basson	Saul	General Worker	Siyamthemba Municipality
Mr	Berries	Lorenzo		
Mr	Boesak	Klaas Cornelius		
Mr	Bosman	Wessel		
Mr	Botha	Ernest		
Mr	Botha	Martin		Gemeerskaps Forum
Mr	Botha	Thomas		
Mr	George	Desmond		
Mrs	Griewes	Jennalina		
Mr	Hendricks	Benjamin Brendon		
Ms	Hendricks	Rozelle		
Ms	Hendriks	Elizabeth		
Mr	Isaacs	Jermaine	Construction Manager	BioTherm Energy
Mr	Jansen	Esmond		
Ms	Jenson	Felicity		
Mr	Joko	N		
Mr	Julies	Charl		
Ms	Julies	Danielle		
Mr	Kakora	Le-Waine		
Ms	Kapater	Rene		
Mr	Klein	Quarney		
Mr	Langfred	Justin		
Ms	Ludick	Gertruida		
Mr	Ludidi	William		
Mr	Mafiest	Jacob		
Ms	Magakwe	Beatrice		
Mr	Majebe	Killek		
Ms	Malgas	Gertruida		
Ms	Maritz	Sharon		
Mr	Maritz	Vivian	General Worker	
Mr	Matti	Collin Jansen		
Ms	Mistry	Chetna	Analyst	BioTherm Energy
Mr	Mohlauli	Johannes	General Worker	
Mr	Mpambani	Solomon		
Mr	Mugger	Danster	Secretary Ward 2	
Mr	Ng	Bonisehle	General Worker	
Mr	Nkone	Sonwabo		
Mr	Nohenda	H		
Mr	Papier	Piet	Mayor	Siyamthemba Municipality
Mr	Phike	David		Siyamthemba Municipality

Mr	Phike	Mlawuli		
Ms	Pieterse	Nomonde		
Mr	Plaatjies	George	Secretary	Siyamthemba Municipality
Ms	Puzane	Petronella		
Ms	Richardson	Irene	Environmental Manager	BioTherm Energy
Ms	Rimbault	Lynsey	Environmental Consultant	SiVEST
Mr	Roos	Nicolas Klaas		
Ms	Scott	Rosetta		
Ms	Smith	Eliska		
Mr	Smith	Randall		
Ms	Staden	Senobia		
Ms	Stadhauer	Raylene		
Mr	Swarts	Presley		
Ms	Tieties	Christina		
Mr	Van der Westhuisen	Desmond		
Mr	Van Staden	Johannes		
Mr	Van Staden	Kerneels		
Mr	Van Staden	Rudolf		
Mrs	Van Wyk	F.M.	Ward 2 Counsellor	Siyamthemba Municipality
Mrs	Van Wyk	Mirna		
Mr	Van Wyk	Pieter		
Ms	Venter	Nicolene	Public Participation Practitioner	Zitholele
Mr	Visser	David	General Worker	
Mr	William	Eden		
Ms	Yanla	Sanna		
Mr	Yawa	Benjamin		

Annexure B

COPY OF PRESENTATION

**ENVIRONMENTAL IMPACT ASSESSMENT FOR THE
PROPOSED CONSTRUCTION OF THE THREE HELENA
75MW SOLAR PHOTOVOLTAIC (PV) ENERGY
FACILITIES NEAR COPPERTON, NORTHERN CAPE
PROVINCE: DRAFT SCOPING REPORT**

DEA Reference Number:
HELENA SOLAR 1: 14/12/16/13/3/2/165
HELENA SOLAR 2: 14/12/16/13/3/2/166
HELENA SOLAR 3: 14/12/16/13/3/2/167

A PROFESSIONAL TEAM DELIVERING CREATIVE PROJECT SOLUTIONS

SIVEST

Consulting Engineers • Project Managers • Environmental Consultants • Town and Regional Planners

PUBLIC MEETING

PRESENTATION DATE: 21 May 2015

1

AGENDA

- Welcome, introduction and apologies
- Purpose and conduct of meeting
- Background to the proposed development
- Environmental process followed and desktop findings
- BioTherm Economic Development Strategy
- Discussion session
- Closure

2

CONDUCT OF MEETING

- Focus on issues relating to the EIA
- Equal participation
- Identify yourselves
- Recorder
- Cell phone etiquette

3

PURPOSE OF MEETING

- To provide an overview of the proposed project
- To provide feedback on the desktop findings as documented in the DSR
- Provide an opportunity to raise comments and/or concerns regarding the proposed project
- To record comments, issues and concerns raised

4

PROJECT OVERVIEW

5

PROJECT OVERVIEW

- **What does the proposed development entail?**
 - Construction of three PV energy facilities, each with a maximum generation capacity of 75MW
 - Construction of associated infrastructure
 - New power lines from the PV energy facilities to the Eskom grid
 - New substations
 - Access road upgrades
 - Construction laydown areas
 - Admin and warehouse buildings
- **Why is the project being proposed?**
 - To generate electricity to feed into the national grid
 - Promote use of renewable energy
 - To help meet future energy consumption requirements

6

DESKTOP FINDINGS **BIVEST**

- **Scoping phase underway**
 - Issues based, desk-top investigation
 - Identify potential issues for further investigated in the EIA phase
- **Environmental aspects being assessed**
 - Biodiversity (flora and fauna)
 - Avifauna
 - Surface Water
 - Soil and Agricultural Potential
 - Visual
 - Heritage
 - Socio-economic

13

DESKTOP FINDINGS **BIVEST**

- **Biodiversity Assessment**
 - The project is unlikely to have highly significant impacts on the ecological receiving environment.
 - Impacts that will occur can be controlled and reduced to low significance.
 - The seriousness of many of these impacts can be determined during the field investigation of the site. Some impacts may require permits to be issued.



14

DESKTOP FINDINGS **BIVEST**

- **Avifaunal Assessment**
 - With over a quarter of all southern African endemics or near endemics potentially occur in the study area, the study area as a whole should be regarded as moderately sensitive from an avifaunal perspective.
 - Potential high sensitive, no-go areas were identified, i.e. surface water (water troughs and dams) and high voltage lines, as both these micro-habitats are potential focal points of bird activity.
 - Water troughs may be removed and therefore declassified
 - High voltage lines included as a precaution – buffers will be removed if there are no nests present



15

DESKTOP FINDINGS **BIVEST**

- **Surface Water Assessment**
 - Database findings revealed that two natural depression wetlands, and two non-perennial rivers are located within the study area.
 - Desktop findings reveal:
 - Four depression wetlands; and
 - Two unnamed, non-perennial rivers.



16

DESKTOP FINDINGS **BIVEST**

- **Soils and Agricultural Assessment**
 - Virtually all of the study area comprises shallow, calcareous soils with rock.
 - Coupled with these shallow soils, the very low rainfall in the area means that the only means of cultivation would be by irrigation and the Google Earth image of the area shows absolutely no signs of any agricultural infrastructure and certainly none of irrigation.
 - The climatic restrictions mean that this part of the Northern Cape is suited at best for grazing and here the grazing capacity is low, around 20 ha/large stock unit.
 - Therefore the expected impact is low, as soils are shallow and climate is very unfavourable for cultivation.

17

DESKTOP FINDINGS **BIVEST**

- **Visual Impact Assessment**
 - The study area has a rural visual character with a low visual sensitivity.
 - However, several solar energy facilities are proposed within relatively close proximity to the proposed PV plant, which will alter the visual character.
 - The proposed PV plant development is likely to visually influence four farmsteads identified within the visual assessment zone, therefore these are regarded to be potentially sensitive visual receptor locations.
 - The sensitivity of the receptor locations will need to be confirmed through further assessment in the next phase of the study.



18

DESKTOP FINDINGS BIVEST

- **Heritage Assessment**
 - The possibility of archaeological finds have been identified as being high.
 - The palaeontological potential of the area has been confirmed as being low.
 - As seen from the archival in the heritage scoping report, the possibility of historical finds has been identified.
 - Thus further fieldwork is required to develop a comprehensive Heritage Management Plan.



19

DESKTOP FINDINGS BIVEST

- **Socio-economic Assessment**
 - The national, provincial, and to some extent local government prioritise the development of renewable energy projects.
 - However, these developments should not jeopardise the growth of the other sectors, especially agriculture which is considered to be an economic driver in the local area.
 - The economy is in dire need for investment that would:
 - Diversity its economic base
 - Improve standards of living among local households through the increased income levels and access to improved municipal services
 - The proposed project is therefore likely to create a positive impact on the local economic development and the socio-economic environment in the municipality in general.

20

EIA PHASE STUDIES BIVEST

- Detailed studies to be undertaken in the EIA phase:
 - Biodiversity (flora and fauna)
 - Avifauna
 - Surface Water
 - Soil and Agricultural Potential
 - Visual
 - Heritage
 - Socio-economic

21

EIA PHASE STUDIES BIVEST

- **Issues to be addressed**
 - Undertake detailed fieldwork
 - Verify desktop findings
 - Rate the significance of impacts
 - Comparatively assess on site alternatives
 - Determine mitigation measures
 - Compile Environmental Management Programme

22

PUBLIC PARTICIPATION

BIVEST

23

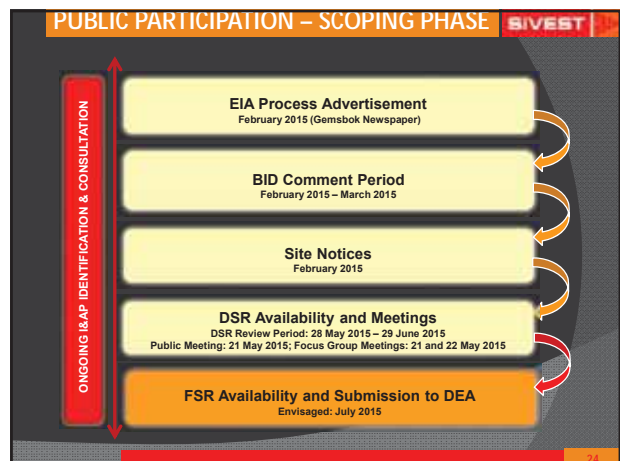

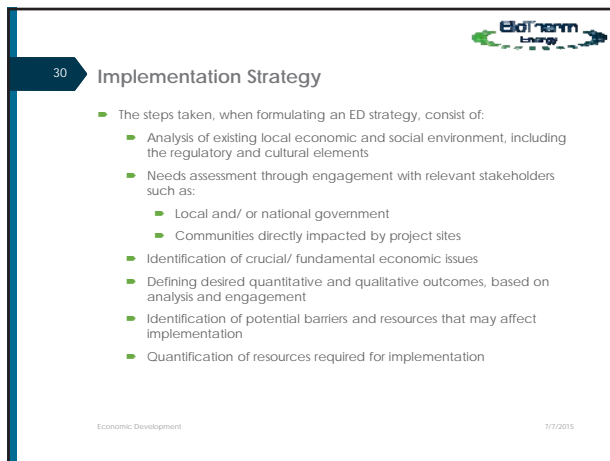
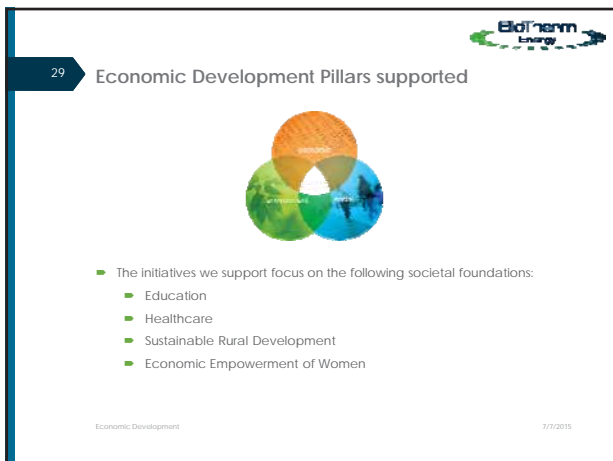
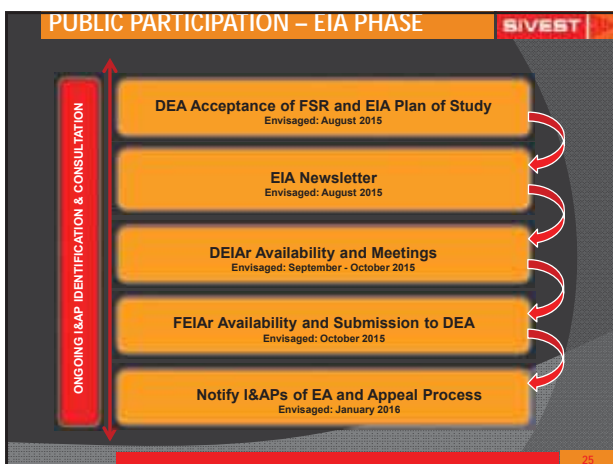

31 Implementation Strategy (Cont'd)

- Development of an action plan, including elements such as:
 - Work Task
 - Budget Required
 - Funding Source
 - Responsible Party
 - Completion Date
 - Progress Measurement Tool
- Monitoring, evaluation and update of strategy, if and when necessary



Economic Development 7/7/2015

32 Track Record

- Examples of initiatives implemented in South Africa include:
 - The upgrade of teaching equipment at a primary school in the Northern Cape, South Africa;
 - The provision of critical medical equipment to the local clinics and hospitals within various communities of the Northern Cape and Western Cape, South Africa;
 - The electrification of an Early Childhood Development (ECD) Centre in the Northern Cape, South Africa;
 - Infrastructural upgrades at an old age home in the Western Cape, South Africa, thus allowing them to qualify for better grant funding and accreditation;
 - Sponsorship of a "woman abuse awareness campaign" run by the South African Police Services in the Northern Cape, South Africa;

Economic Development 7/7/2015

33 Track Record (Cont'd)

- Supply of infantile mattresses to an ECD Centre in the Western Cape, South Africa;
- Provision of daily consumables to a disadvantage teenager diagnosed with Spina Bifida in the Western Cape, South Africa; and
- Sponsorship of a primary and high school principal to attend the Principal's Academy within the Western Cape, South Africa



Economic Development 7/7/2015

DISCUSSION

34

CONTACT DETAILS

SIVEST Environmental Division
 PO Box 2921
 Rivonia
 2128

Andrea Gibb / Lynsey Rimbault
 Phone: (011) 798 0600
 Fax: (011) 803 7272
 E-mail: andreag@sivest.co.za / lynseyr@sivest.co.za
 Website: www.sivest.co.za

35

WAY FORWARD

	2015							2016
	June	July	Aug	Sep	Oct	Nov	Dec	Jan
End of DSR comment period	☀							
Submission of FSR to DEA		☀						
DEA decision on FSR			☀					
Distribution of EIA Newsletter			☀					
DEIAR Comment period				☀	☀			
Hold Meetings (FGM and PM)				☀				
Submission of FEIAR to DEA					☀			
DEA Decision								☀

36

Annexure C

DISCUSSION DOCUMENT

**OMGEWINGSIMPAKEVALUERING (OIE) EN OMGEWINGSBESTUURSPROGRAME
(OBPr) VIR DIE VOORGESTELDE ONTWIKKELING VAN DRIE 75MW FOTOVOLTAÏSE
(FV) SONKRAGANLEGTE NA BY COPPERTON, NOORD-KAAPPROVINSIE**

**ENVIRONMENTAL IMPACT ASSESSMENT (EIA) AND ENVIRONMENTAL
MANAGEMENT PROGRAMME (EMPr) FOR THE PROPOSED DEVELOPMENT OF
THREE 75MW SOLAR PHOTOVOLTAIC (PV) ENERGY FACILITIES NEAR
COPPERTON, NORTHERN CAPE PROVINCE**

HELENA SOLAR 1: DO Verw./DEA Ref. No.: 14/12/16/3/3/2/765

HELENA SOLAR 2: DO Verw. /DEA Ref. No.: 14/12/16/3/3/2/766

HELENA SOLAR 3: DO Verw. /DEA Ref. No.: 14/12/16/3/3/2/767

**FINALE BESPREKINGSKOKUMENT / FINAL DISCUSSION DOCUMENT
PUBLIEKEVERGADERING / PUBLIC MEETING**

Omegasaal, Alwynstraat, / Omega Hall, Alwyn Street
Bonteheuwel, Prieska

Donderdag, 21 Mei 2015 om 16h30 / Thursday, 21 May 2015 at 16h30

INHOUDSOPGAWE / TABLE OF CONTENTS

1.	Sosio-Ekonomiese Aanverwante Kommentare/Kwessies - Socio-Economic Related Comments/Issues	1
2.	OIE Prosess Aanverwante Kommentare/Kwessies - EIA Process Related Comments/Issues	1
3.	Projek Aanverwante Kommentare/Kwessies - Project Related Comments/Issues	2

Kommentare / kwellinge / kwessies is gekategoriseer volgens die omgewingsimpakte and daarna volgens VANNE van teenwoordiges
Comments / concerns / issues have been categorised according to environmental impact and thereafter according to attendees' SURNAME.

Die kommentare / kwessies / kwellinge is nie verbatim vasgelê nie, maar wel 'n verkorte opsomming daarvan
The comments / concerns / issues captured are not verbatim, but a summary.

Issue/Comment	Raised By & When	Response
1. Sosio-Ekonomiese Aanverwante Kommentare/Kwessies - Socio-Economic Related Comments/Issues		
<p>Dit was verneem hoeveel werksgeleenthede die voorgestelde projek sal bied.</p> <p>Translation: It was enquired as to how many jobs the proposed project will create.</p>	<p>VAN WYK, FM Raadslid: Wyk 2/ Councilor Region 2</p>	<p>BioTherm is die ontwikkelaar en die syfers rakende moontlike werksgeleenthede tydens konstruksie sal slegs beskikbaar wees wanneer 'n kontrakteur aangestel is. Die syfers is nie op hierdie stadium van die OIE beskikbaar nie.</p> <p>Irene Bezuidenhout, Environmental Manager, BioTherm Energy</p> <p>Translation: BioTherm is the developer and the figures regarding possible job opportunities that would be available during the construction phase will only be made available once a contractor has been appointed. The figures are not available at this stage of the EIA.</p> <p>Irene Bezuidenhout, Environmental Manager, BioTherm Energy</p>
2. OIE Proses Aanverwante Kommentare/Kwessies - EIA Process Related Comments/Issues		
<p>Dit was verneem wanneer sal die volgende vergaderings rakende die projek plaasvind?</p> <p>Translation: It was enquired as to when the next round of meetings for the proposed project will be.</p>	<p>VAN WYK, FM Raadslid: Wyk 2 / Councilor Region 2</p>	<p>Soos aangebied is dit die verwagting dat die volgende vergadering wat in die impakfase sal plaasvind in September of Oktober 2015.</p> <p>Nicolene Venter, Publieke Deelname Konsultant, Zitholele Consulting</p> <p>Translation: As per the presentation it is envisaged that the next round of meetings, in the impact phase, will take place in September or October 2015.</p> <p>Nicolene Venter, PP Practitioner, Zitholele Consulting</p>

3. Projek Aanverwante Kommentare/Kwessies - Project Related Comments/Issues

Dit was verneem hoeveel panele is nodig vir die opwekking deur 'n 75MW aanleg.

Translation:

It was enquired as to how many panels will be required for the generation by a 75MW plant.

BOTHA, Martin
Voorsitter / Chairman
Gemeenskapsforum /
Community Forum

Die inligting is tans nie beskikbaar nie aangesien n modulering wat hierdie inligting sal kan verskaf, eers later in die proses gedoen sal word.

Irene Bezuidenhout, Environmental Manager, BioTherm Energy

Na-vergaderingsnota:

Vir 'n 75MW fasiliteit sal daar ongeveer 286 666 panele geïnstalleer word. Slegs na die finale tegniese ontwerp gedoen is, sal die presiese getal beskikbaar wees.

Irene Bezuidenhout, Environmental Manager, BioTherm Energy

Translation:

The information is not available at this stage of the project as the modeling that will determine this still needs to be done.

Irene Bezuidenhout, Environmental Manager, BioTherm Energy

Post Meeting Note

For a 75MW facility there will be approximately 286 666 panels installed. The exact figure will only be determined with final technical design.

Irene Bezuidenhout, Environmental Manager, BioTherm Energy

Dit was verneem as alle studies en die aanstelling van 'n kontrakteur afgehandel is, wanneer sal die eerste graaf in die grond wees.

Translation:

Following the completion of all studies and the appointment of a contractor, it was queried how long is it likely to be before construction begins

Die verwagting is oor sowat 2 jaar, maar die tydperk is op hierdie stadium nog nie bevestig nie. Konstruksie is afhanklik of die projek in Rondte 5 van die Departement van Energie se Hernubare Energie Onafhanklike Kragvoorsiener Verkrygingsprogramme (REIPLPPP) verkies word as 'n voorkeurbiëër.

Irene Bezuidenhout, Environmental Manager, BioTherm Energy

Translation:

		<p>It is envisaged that construction will commence in approximately 2 years but this timeframe has not been confirmed at this stage. Construction is dependent on the project being selected as the preferred bidder under Round 5 of the Department of Energy's (DoE) Renewable Energy Independent Power Producer Procurement Programme (REIPPPP).</p> <p><i>Irene Bezuidenhout, Environmental Manager, BioTherm Energy</i></p>
--	--	---



**Appendix 5H:
Landowner Notifications**

Lynsey Rimbault

From: Lynsey Rimbault
Sent: 26 May 2015 12:16
To: 'huisdanie@telkomsa.net'
Subject: Proposed Helena Solar PV Energy Facilities
Attachments: Helena EIA LO Letter Rev 1 26 May 2015 LR Danie and Jomima Bernard.pdf

Dear Danie and Jomima Bernard,

Please see attached a letter notifying you of the Environmental Impact Assessment (EIA) that is being undertaken for the three proposed Helena 75MW Solar Photovoltaic Energy Facilities.

Kind Regards

Lynsey Rimbault *(B.Sc.(Hons) Geography; M.Sc. Biodiversity, Conservation and Management)*
Environmental Consultant
SiVEST Environmental



SiVEST is a Level 3 BBBEE Contributor

Direct +27 11 798 0631 **Tel** +27 11 798 0600 **fax** +27 11 803 7272 **cell** +27 82 669 9558
email lynseyr@sivest.co.za **website** www.sivest.co.za



Consulting Engineers - Project Managers - Environmental Consultants - Town and Regional Planners
Durban - Johannesburg - Pietermaritzburg - Richards Bay - Ladysmith - Cape Town - Harare (Zimbabwe)

Lynsey Rimbault

From: Charl van der Merwe <huisdanie@telkomsa.net>
To: Lynsey Rimbault
Sent: 26 May 2015 12:49
Subject: Read: Proposed Helena Solar PV Energy Facilities

Your message

To:
Subject: Read: Proposed Helena Solar PV Energy Facilities
Sent: 26 May 2015 12:49:25 PM (UTC+02:00) Harare, Pretoria

was read on 26 May 2015 12:49:12 PM (UTC+02:00) Harare, Pretoria.

Your reference:

Our reference: 13031

Date: 26 May 2015

**ATTENTION: DANIE AND JOMIMA BERNARD
PORTION 4 OF THE FARM KLIPGATS PAN 117**

Via Email

Dear Danie and Jomima Bernard,

ENVIRONMENTAL IMPACT ASSESSMENT (EIA) FOR THE PROPOSED CONSTRUCTION OF THREE 75MW HELENA SOLAR PHOTOVOLTAIC (PV) ENERGY FACILITIES NEAR COPPERTON, NORTHERN CAPE PROVINCE

DEA REFERENCE NO.:

- **HELENA SOLAR 1: 14/12/16/3/3/2/765**
- **HELENA SOLAR 2: 14/12/16/3/3/2/766**
- **HELENA SOLAR 3: 14/12/16/3/3/2/767**

BioTherm Energy (Pty) Ltd (hereafter referred to as BioTherm) are proposing to construct three solar photovoltaic (PV) energy facilities and associated infrastructure approximately 10km south of Copperton. Each facility will have a total generation capacity of approximately 75MW.

BioTherm has appointed SiVEST as the independent Environmental Assessment Practitioner (EAP) to undertake the required Environmental Impact Assessment (EIA) for the above-mentioned proposed developments.

As the landowner of one of the properties traversed by the proposed power line alternatives, we would like to inform you of the EIA that is being undertaken for these proposed developments as per the National Environmental Management Act, 1998 (Act No 107 of 1998) – EIA Regulations 2010.

Yours sincerely

A handwritten signature in black ink, appearing to read "Andrea Gibb".

Andrea Gibb
Environmental Practitioner
SiVEST Environmental Division

Your reference:

Our reference: 13031

Date: 26 May 2015

**ATTENTION: GERHARDUS JACOBUS RUDOLPH
PORTION 3 OF THE FARM KLIPGATS PAN 117**

Via Email

Dear Gerhardus Jacobus Rudolph

ENVIRONMENTAL IMPACT ASSESSMENT (EIA) FOR THE PROPOSED CONSTRUCTION OF THREE 75MW HELENA SOLAR PHOTOVOLTAIC (PV) ENERGY FACILITIES NEAR COPPERTON, NORTHERN CAPE PROVINCE

DEA REFERENCE NO.:

- **HELENA SOLAR 1: 14/12/16/3/3/2/765**
- **HELENA SOLAR 2: 14/12/16/3/3/2/766**
- **HELENA SOLAR 3: 14/12/16/3/3/2/767**

BioTherm Energy (Pty) Ltd (hereafter referred to as BioTherm) are proposing to construct three solar photovoltaic (PV) energy facilities and associated infrastructure approximately 10km south of Copperton. Each facility will have a total generation capacity of approximately 75MW.

BioTherm has appointed SiVEST as the independent Environmental Assessment Practitioner (EAP) to undertake the required Environmental Impact Assessment (EIA) for the above-mentioned proposed developments.

As the landowner of one of the properties on which the project is proposed to occur, we would like to inform you of the EIA that is being undertaken for these proposed developments as per the National Environmental Management Act, 1998 (Act No 107 of 1998) – EIA Regulations 2010.

Yours sincerely



Andrea Gibb
Environmental Practitioner
SiVEST Environmental Division