

25 October 2018

Mr Pheladi Masipa
Acting Project Manager: Renewable energy Initiatives
Department of Energy
192 Visagie Street
PRETORIA 0002

Per Courier

Dear Mr Masipa,

**ENVIRONMENTAL IMPACT ASSESSMENT AND PUBLIC PARTICIPATION PROCESSES FOR THE PROPOSED
HYPERION SOLAR DEVELOPMENT 1, 2, 3 and 4 AND ASSOCIATED INFRASTRUCTURES NEAR KATHU,
NORTHERN CAPE PROVINCE**

NOTICE OF AVAILABILITY OF THE SCOPING REPORTS FOR REVIEW AND WRITTEN COMMENTS

The development of four (4) separate photovoltaic (PV) solar energy facilities (SEFs) as well as associated infrastructure are being proposed on the Remaining Extent of the Farm Lyndoch 432 situated ~16km north of Kathu in the Northern Cape Province. The proposed SEFs fall within the jurisdiction of the Gamagara Local Municipality and within the greater John Taolo Gaetsewe District Municipality.

Each of the four (4) SEFs will be constructed as separate stand-alone projects, with a separate project development company (or Special Purpose Vehicle) as the applicant for each project. The projects are:

Project Name:	Applicant:
Hyperion Solar Development 1	Hyperion Solar Development 1 (Pty) Ltd
Hyperion Solar Development 2	Cyraguard (Pty) Ltd
Hyperion Solar Development 3	Nomispan (Pty) Ltd
Hyperion Solar Development 4	Nomispan (Pty) Ltd

This letter serves to inform you that the Scoping Reports (SRs) are available for your Department's review and written comments, and a CD containing the SRs is included in this envelope.

Please note that the SRs' review period is from **Friday, 26 October 2018** to **Monday, 26 November 2018** and we are looking forward receiving your Department's written comment on the SRs before or on the closing date of the review period.

Kind regards



Nicolene Venter
Public Participation and Social Consultant
Savannah Environmental

Waybill Summary Details

Waybill Number :	1298110520	Waybill Date :	2018-10-26
Waybill Status :	POD RECEIVED	Service :	%%ServiceType%%
From :	JOHANNESBURG CENTRAL AREAS	To :	PRETORIA CENTRAL AREAS
Sender :	SAVANNAH ENVIRONMENT 5 WOODLANDS DRIVE OFFICE PARK CNR WOODLANDS DR & WESTERN SERVICE ROAD WOODMEAD EXT 2191	Receiver :	DEPARTMENT OF ENERGY 192 VISAGIE STREET PRETORIA 0002
Contact :	%%SenContact%%	Contact :	PHELADI MASIPA
Telephone :	%%SenTelNo%%	Telephone :	0124067660
Cellphone :	%%SenCelNo%%	Cellphone :	%%RecCelNo%%
Customer Ref :	%%InvoiceRefNo%%	Collection No :	
Total Parcels :	1	Total Mass :	0.10
Total Volume :	0.24	Value :	

Proof of Delivery

Received By	Date Received	Time	Parcels
Beryl Reception	2018-10-29	09:54	1

Detailed track and trace

Event	Location	Date	Time	Additional Information
SHIPMENT RECEIVED BY HUB	JNB	2018-10-26	21:39	
MASS DIMENSION VERIFICATION	JNB	2018-10-26	21:39	
SHIPMENT SHIPPED FROM DEPOT	JNB	2018-10-26	21:51	
PARCEL HAS LEFT DAWN WING	PRY	2018-10-29	07:25	
POD RECEIVED / DELIVERED	PRY	2018-10-29	10:07	

[Back](#)

25 October 2018

Ms Wilma Lutsch
Director: Biodiversity Conservation
Department of Environmental Affairs
Environmental House
473 Steve Biko Road
PRETORIA 0002

By Hand

Dear Ms Lutsch,

**ENVIRONMENTAL IMPACT ASSESSMENT AND PUBLIC PARTICIPATION PROCESSES FOR THE PROPOSED
HYPERION SOLAR DEVELOPMENT 1, 2, 3 and 4 AND ASSOCIATED INFRASTRUCTURES NEAR KATHU,
NORTHERN CAPE PROVINCE**

NOTICE OF AVAILABILITY OF THE SCOPING REPORTS FOR REVIEW AND WRITTEN COMMENTS

The development of four (4) separate photovoltaic (PV) solar energy facilities (SEFs) as well as associated infrastructure are being proposed on the Remaining Extent of the Farm Lyndoch 432 situated ~16km north of Kathu in the Northern Cape Province. The proposed SEFs fall within the jurisdiction of the Gamagara Local Municipality and within the greater John Taolo Gaetsewe District Municipality.

Each of the four (4) SEFs will be constructed as separate stand-alone projects, with a separate project development company (or Special Purpose Vehicle) as the applicant for each project. The projects are:

Project Name:	Applicant:
Hyperion Solar Development 1	Hyperion Solar Development 1 (Pty) Ltd
Hyperion Solar Development 2	Cyraguard (Pty) Ltd
Hyperion Solar Development 3	Nomispank (Pty) Ltd
Hyperion Solar Development 4	Nomispan (Pty) Ltd

This letter serves to inform you that the Scoping Reports (SRs) are available for your Organisation's view and written comments, and a CD containing the SRs is included in this envelope.

Please note that the SRs' review period is from **Friday, 26 October 2018** to **Monday, 26 November 2018** and we are looking forward receiving your Organisation's written comment on the SRs before or on the closing date of the review period.

Kind regards



Nicolene Venter
Public Participation and Social Consultant
Savannah Environmental

MEMO

DATE:	26 October 2018
TO:	Department of Environmental Affairs
ATT:	Wilma Lutch
REFERENCE:	N/A
OUR REFERENCE:	SE2167

Please find attached x1Protected CD of the Scoping Report for public review for Hyperion Solar Development 1, 2, 3 & 4, Northern Cape Province.

NAME OF RECIPIENT:

[Handwritten Signature]

SIGNATURE:

ENVIRONMENTAL AFFAIRS
INT ENV AUTH

DATE RECEIVED:

2018 -10- 26

STAMP:

SIGN: *[Handwritten Signature]*

25 October 2018

Mr Kevin Mutheiwana
Regional Manager: Northern Cape Province
Department of Mineral Resources
Hopley Centre
Cnr Van der Stel & Van Riebeeck Street
SPRINGBOK 8240

Per Courier

Dear Mr Matheiwana,

**ENVIRONMENTAL IMPACT ASSESSMENT AND PUBLIC PARTICIPATION PROCESSES FOR THE PROPOSED
HYPERION SOLAR DEVELOPMENT 1, 2, 3 and 4 AND ASSOCIATED INFRASTRUCTURES NEAR KATHU,
NORTHERN CAPE PROVINCE**

NOTICE OF AVAILABILITY OF THE SCOPING REPORTS FOR REVIEW AND WRITTEN COMMENTS

The development of four (4) separate photovoltaic (PV) solar energy facilities (SEFs) as well as associated infrastructure are being proposed on the Remaining Extent of the Farm Lyndoch 432 situated ~16km north of Kathu in the Northern Cape Province. The proposed SEFs fall within the jurisdiction of the Gamagara Local Municipality and within the greater John Taolo Gaetsewe District Municipality.

Each of the four (4) SEFs will be constructed as separate stand-alone projects, with a separate project development company (or Special Purpose Vehicle) as the applicant for each project. The projects are:

Project Name:	Applicant:
Hyperion Solar Development 1	Hyperion Solar Development 1 (Pty) Ltd
Hyperion Solar Development 2	Cyraguard (Pty) Ltd
Hyperion Solar Development 3	Nomispark (Pty) Ltd
Hyperion Solar Development 4	Nomispan (Pty) Ltd

This letter serves to inform you that the Scoping Reports (SRs) are available for your Department's review and written comments, and a CD containing the SRs is included in this envelope.

Please note that the SRs' review period is from **Friday, 26 October 2018** to **Monday, 26 November 2018** and we are looking forward receiving your Department's written comment on the SRs before or on the closing date of the review period.

Kind regards



Nicolene Venter

**Public Participation and Social Consultant
Savannah Environmental**

Waybill Summary Details

Waybill Number :	1298110601	Waybill Date :	2018-10-26
Waybill Status :	POD RECEIVED	Service :	%%ServiceType%%
From :	JOHANNESBURG CENTRALAREAS	To :	SOUTH AFRICA REMOTE T/SHIPS
Sender :	SAVANNAH ENVIRONMENT 5 WOODLANDS DRIVE OFFICE PARK CNR WOODLANDS DR & WESTERN SERVICE ROAD WOODMEAD EXT 2191	Receiver :	DEPARTMENT OF MINERAL RESOURCES CNR STEL & VAN RIEBEECK S TREET SPRINGBOK SPRINGBOK 8240
Contact :	%%SenContact%%	Contact :	KEVIN
Telephone :	%%SenTelNo%%	Telephone :	0538071707
Cellphone :	%%SenCelNo%%	Cellphone :	%%RecCelNo%%
Customer Ref :	%%InvoiceRefNo%%	Collection No :	
Total Parcels :	1	Total Mass :	0.10
Total Volume :	0.02	Value :	

Proof of Delivery

Received By	Date Received	Time	Parcels
ANN	2018-10-30	09:27	1

Detailed track and trace

Event	Location	Date	Time	Additional Information
SHIPMENT RECEIVED BY HUB	JNB	2018-10-26	21:39	
MASS DIMENSION VERIFICATION	JNB	2018-10-26	21:39	
SHIPMENT SHIPPED FROM DEPOT	JNB	2018-10-26	21:53	
SHIPMENT RECEIVED BY DEPOT	CPT	2018-10-28	22:24	
SHIPMENT SHIPPED FROM DEPOT	CPT	2018-10-29	07:12	
POD RECEIVED / DELIVERED	SBU	2018-10-30	09:55	

[Back](#)

25 October 2018

Dr Nozizwe Makgalemele
Deputy Director-General; Spatial Land-Use and Management
Department of Rural Development and Land Reform
Old Building
184 Jacob Mare Street
PRETORIA 0001

Per Courier

Dear Dr Makgalemele,

**ENVIRONMENTAL IMPACT ASSESSMENT AND PUBLIC PARTICIPATION PROCESSES FOR THE PROPOSED
HYPERION SOLAR DEVELOPMENT 1, 2, 3 and 4 AND ASSOCIATED INFRASTRUCTURES NEAR KATHU,
NORTHERN CAPE PROVINCE**

NOTICE OF AVAILABILITY OF THE SCOPING REPORTS FOR REVIEW AND WRITTEN COMMENTS

The development of four (4) separate photovoltaic (PV) solar energy facilities (SEFs) as well as associated infrastructure are being proposed on the Remaining Extent of the Farm Lyndoch 432 situated ~16km north of Kathu in the Northern Cape Province. The proposed SEFs fall within the jurisdiction of the Gamagara Local Municipality and within the greater John Taolo Gaetsewe District Municipality.

Each of the four (4) SEFs will be constructed as separate stand-alone projects, with a separate project development company (or Special Purpose Vehicle) as the applicant for each project. The projects are:

Project Name:	Applicant:
Hyperion Solar Development 1	Hyperion Solar Development 1 (Pty) Ltd
Hyperion Solar Development 2	Cyraguard (Pty) Ltd
Hyperion Solar Development 3	Nomispank (Pty) Ltd
Hyperion Solar Development 4	Nomispan (Pty) Ltd

This letter serves to inform you that the Scoping Reports (SRs) are available for your Department's review and written comments, and a CD containing the SRs is included in this envelope.

Please note that the SRs' review period is from **Friday, 26 October 2018** to **Monday, 26 November 2018** and we are looking forward receiving your Department's written comment on the SRs before or on the closing date of the review period.

Kind regards



Nicolene Venter
Public Participation and Social Consultant
Savannah Environmental

Waybill Summary Details

Waybill Number :	1298110612	Waybill Date :	2018-10-26
Waybill Status :	POD RECEIVED	Service :	%%ServiceType%%
From :	JOHANNESBURG CENTRAL AREAS	To :	PRETORIA CENTRAL AREAS
Sender :	SAVANNAH ENVIRONMENT 5 WOODLANDS DRIVE OFFICE PARK CNR WOODLANDS DR & WESTERN SERVICE ROAD WOODMEAD EXT 2191	Receiver :	DEPARTMENT OF RURAL DEVELOPMENT AND LAND RREFORM MENT AND LAND REFORM OLD BUILDING 184 JACOB MARE STREET PRETORIA CENTRAL 0001
Contact :	%%SenContact%%	Contact :	NOZIZWE MAKGALEMELE
Telephone :	%%SenTelNo%%	Telephone :	0123128006
Cellphone :	%%SenCelNo%%	Cellphone :	%%RecCelNo%%
Customer Ref :	%%InvoiceRefNo%%	Collection No :	
Total Parcels :	1	Total Mass :	0.10
Total Volume :	0.24	Value :	

Proof of Delivery

Received By	Date Received	Time	Parcels
Finalized : RTSBIL	2018-11-09	19:36	1

Detailed track and trace

Event	Location	Date	Time	Additional Information
SHIPMENT SHIPPED FROM DEPOT	JNB	2018-10-26	21:36	
SHIPMENT RECEIVED BY HUB	JNB	2018-10-26	21:39	
MASS DIMENSION VERIFICATION	JNB	2018-10-26	21:39	
PARCEL HAS LEFT DAWN WING	PRY	2018-10-29	07:25	
DAWN WING WILL CONTACT YOU	PRY	2018-10-29	09:46	
PARCEL HAS LEFT DAWN WING	PRY	2018-10-30	07:25	
DAWN WING WILL CONTACT YOU	PRY	2018-10-30	09:39	
SHIPMENT RECEIVED BY DEPOT	PRY	2018-11-09	04:12	
POD RECEIVED / DELIVERED	PRY	2018-11-09	19:38	

[Back](#)

25 October 2018

Mr Abe Abrahams
Chief Director
Department of Water and Sanitation
28 Central Road
Beaconsfield
KIMBERLEY 8301

Per Courier

Dear Mr Abrahams,

**ENVIRONMENTAL IMPACT ASSESSMENT AND PUBLIC PARTICIPATION PROCESSES FOR THE PROPOSED
HYPERION SOLAR DEVELOPMENT 1 AND ASSOCIATED INFRASTRUCTURES NEAR KATHU, NORTHERN
CAPE PROVINCE**

NOTICE OF AVAILABILITY OF THE SCOPING REPORT FOR REVIEW AND WRITTEN COMMENTS

Hyperion Solar Development 1 (Pty) Ltd, the developer, is proposing the development of the Hyperion Solar Photovoltaic (PV) 1 solar energy facility and associated infrastructure on the Remaining Extent of the Farm Lyndoch 432 situated ~16km north of Kathu in the Northern Cape Province. The proposed development falls within the jurisdiction of the Gamagara Local Municipality and within the greater John Taolo Gaetsewe District Municipality.

This letter serves to inform you that the Scoping Report (SR) is available for your Department's review and written comments, and a hard copy and CD containing the SR is included in this envelope.

Please note that the SR's review period is from **Friday, 26 October 2018** to **Monday, 26 November 2018** and we are looking forward receiving your Department's written comment on the SR before or on the closing date of the review period.

Kind regards



Nicolene Venter

**Public Participation and Social Consultant
Savannah Environmental**



a division of dpd LASER

0861 223 224
www.dawnwing.co.za



1298110704

WAYBILL

Sender to complete yellow areas only

FROM: SAVANNAH ENVIRO S A		Contents: CH+HC		HAZARDOUS YES NO		Filing Ref: 2167	
Address: 1ST FLOOR, BLOCK 2 5 WOODLANDS DRIVE WOODMEAD		No. of Parcels: 1		Parcel Details: 7190NS		SERVICE (mark only one)	
City/Country: WOODMEAD		Postal Code: 2128		Dimensions (cm): 40 30 7		<input checked="" type="checkbox"/> Economy Cargo <input type="checkbox"/> Domestic Road Freight <input type="checkbox"/> Sunday Express <input type="checkbox"/> International Documents <input type="checkbox"/> International Air Freight <input type="checkbox"/> International Road Freight	
Senders Name: LISA		Phone: 011 6563237		Special Instructions: Dawn Wing reserves the right to mark the service "Overnight Express" should no service level be selected		SPECIAL INSTRUCTIONS	
TO: Department of water and Sanitation: 28 Central Road, Beaconsfield		Postal Code: 8301		City/Country: Kimberley		<input type="checkbox"/> Saturday Delivery Collection <input type="checkbox"/> Dawn Delivery W/O Time Required <input type="checkbox"/> After Hours <input type="checkbox"/> Sunday / Public Holiday <input type="checkbox"/> Confirmation of Delivery	
Receiver's Name: Mr Abe Abrahams		Phone: 082-583-6741		Terms strictly 30 days from date of statement		Tick to select limited liability option (to a maximum amount of R50 000) for non-excluded articles: <input type="checkbox"/> Customs Value ZAR: Value of Article ZAR: Account to be Debited: JB6925 Sender's Ref. / Bag No.:	
Senders Name: Febrina		Date: 25-10-18		Collected By Courier: [Signature]		RECEIVED IN GOOD ORDER AND CONDITION	
Signature: [Signature]		Time: [Signature]		CASH AMOUNT R: [] PAID YES NO		Receiver's Signature: [Signature] Print Name: Lindwe Date: 21/10/18 Time: 9:41	

DAWN WING

A Division of DPD Laser Express Logistics (Pty) Ltd
Reg. No. 2006/013251/07 VAT No. 4690215259
FSP NO 32909

*All weight and dimensions subject to verification through electronic weight and dimension machine (SABS calibrated)

PROOF OF DELIVERY

25 October 2018

Ms Andrea van Gensen
Regional Environmental Manager
Eskom Holdings SOC Ltd
120 Henry Street
BLOEMFONTEIN 9301

Per Courier

Dear Ms Van Gensen,

**ENVIRONMENTAL IMPACT ASSESSMENT AND PUBLIC PARTICIPATION PROCESSES FOR THE PROPOSED
HYPERION SOLAR DEVELOPMENT 1, 2, 3 and 4 AND ASSOCIATED INFRASTRUCTURES NEAR KATHU,
NORTHERN CAPE PROVINCE**

NOTICE OF AVAILABILITY OF THE SCOPING REPORTS FOR REVIEW AND WRITTEN COMMENTS

The development of four (4) separate photovoltaic (PV) solar energy facilities (SEFs) as well as associated infrastructure are being proposed on the Remaining Extent of the Farm Lyndoch 432 situated ~16km north of Kathu in the Northern Cape Province. The proposed SEFs fall within the jurisdiction of the Gamagara Local Municipality and within the greater John Taolo Gaetsewe District Municipality.

Each of the four (4) SEFs will be constructed as separate stand-alone projects, with a separate project development company (or Special Purpose Vehicle) as the applicant for each project. The projects are:

Project Name:	Applicant:
Hyperion Solar Development 1	Hyperion Solar Development 1 (Pty) Ltd
Hyperion Solar Development 2	Cyraguard (Pty) Ltd
Hyperion Solar Development 3	Nomispan (Pty) Ltd
Hyperion Solar Development 4	Nomispan (Pty) Ltd

This letter serves to inform you that the Scoping Reports (SRs) are available for your Company's view and written comments, and a CD containing the SRs is included in this envelope.

Please note that the SRs' review period is from **Friday, 26 October 2018** to **Monday, 26 November 2018** and we are looking forward receiving your Company's written comment on the SRs before or on the closing date of the review period.

Kind regards



Nicolene Venter
Public Participation and Social Consultant
Savannah Environmental



a division of dpd LASER

0861 223 224
www.dawnwing.co.za



1298110660

WAYBILL

Sender to complete yellow areas only

FROM: SAVANNAH ENVIRO S A		Contents CD		HAZARDOUS YES NO		Filing Ref: 2167	
Address 1ST FLOOR. BLOCK 2 5 WOODLANDS DRIVE WOODMEAD		PARCEL DETAILS		SERVICE (mark only one)			
City/Country WOODMEAD		Postal Code must be filled in 2128		No. of Parcels ①	Vol(kg)-T's & C's Apply*	Mass(kg)-T's & C's Apply* opposite	<input checked="" type="checkbox"/> Flight <input type="checkbox"/> Economy Cargo <input type="checkbox"/> Domestic Road Freight <input type="checkbox"/> Sameday Express
Senders Name LISA		Phone 011 6563237		Dimensions (cm) 40 30 1		<input type="checkbox"/> International Documents <input type="checkbox"/> International Non Documents <input type="checkbox"/> International Air Freight <input type="checkbox"/> International Road Freight	
TO: Eskom Holdings Soc Ltd		Street Address (P.O. Box Addresses not accepted) Do Henry Street		Dawn Wing reserves the right to mark the service "Overnight Express" should no service level be selected		SPECIAL INSTRUCTIONS <input type="checkbox"/> Saturday Delivery Collection <input type="checkbox"/> Dawn Delivery 9H00 / Time Required <input type="checkbox"/> After Hours <input type="checkbox"/> Sunday / Public Holiday <input type="checkbox"/> Confirmation of Delivery	
City/Country Bloemfontein		Postal Code must be filled in 9301		Terms strictly 30 days from date of statement		Tick to select limited liability option (to a maximum amount of R50 000) for non-excluded articles <input type="checkbox"/> Customs Value ZAR Value of Article ZAR	
Receiver's Name Andriess van Gensen		Phone 082-482-7519		CASH AMOUNT R		PAID YES NO	
Senders Name Georgina		Date 25-10-18		Collected By Courier MST		Date 29/10/18	
Signature 		Time		Date 		Time 08:40	

DAWN WING

A Division of DPD Laser Express Logistics (Pty) Ltd
Reg. No. 2006/033353/07 VAT No. 4690235290
FSP NO 32009

*All weight and dimensions subject to verification through electronic weight and dimension machine (SABS calibrated)

PROOF OF DELIVERY

25 October 2018

Mr John Geeringh
Senior Environmental Manager
Eskom Holdings SOC Ltd
Maxwell Office Park
SUNNINGHILL

Collect at Savannah Environmental

Dear Mr Geeringh,

**ENVIRONMENTAL IMPACT ASSESSMENT AND PUBLIC PARTICIPATION PROCESSES FOR THE PROPOSED
HYPERION SOLAR DEVELOPMENT 1, 2, 3 and 4 AND ASSOCIATED INFRASTRUCTURES NEAR KATHU,
NORTHERN CAPE PROVINCE**

NOTICE OF AVAILABILITY OF THE SCOPING REPORTS FOR REVIEW AND WRITTEN COMMENTS

The development of four (4) separate photovoltaic (PV) solar energy facilities (SEFs) as well as associated infrastructure are being proposed on the Remaining Extent of the Farm Lyndoch 432 situated ~16km north of Kathu in the Northern Cape Province. The proposed SEFs fall within the jurisdiction of the Gamagara Local Municipality and within the greater John Taolo Gaetsewe District Municipality.

Each of the four (4) SEFs will be constructed as separate stand-alone projects, with a separate project development company (or Special Purpose Vehicle) as the applicant for each project. The projects are:

Project Name:	Applicant:
Hyperion Solar Development 1	Hyperion Solar Development 1 (Pty) Ltd
Hyperion Solar Development 2	Cyraguard (Pty) Ltd
Hyperion Solar Development 3	Nomispank (Pty) Ltd
Hyperion Solar Development 4	Nomispan (Pty) Ltd

This letter serves to inform you that the Scoping Reports (SRs) are available for your Company's review and written comments, and a CD containing the SRs is included in this envelope.

Please note that the SRs' review period is from **Friday, 26 October 2018** to **Monday, 26 November 2018** and we are looking forward receiving your Company's written comment on the SRs before or on the closing date of the review period.

Kind regards



Nicolene Venter
Public Participation and Social Consultant
Savannah Environmental

25 October 2018

Mr Thusoeng Itumeleng
Municipal Manager
Gamagara Local Municipality
Civic Centre
Cnr Hendrick van Eck & Frikkie Meyer Road
KATHU 8446

Per Courier

Dear Mr Itumeleng,

**ENVIRONMENTAL IMPACT ASSESSMENT AND PUBLIC PARTICIPATION PROCESSES FOR THE PROPOSED
HYPERION SOLAR DEVELOPMENT 1, 2, 3 and 4 AND ASSOCIATED INFRASTRUCTURES NEAR KATHU,
NORTHERN CAPE PROVINCE**

NOTICE OF AVAILABILITY OF THE SCOPING REPORTS FOR REVIEW AND WRITTEN COMMENTS

The development of four (4) separate photovoltaic (PV) solar energy facilities (SEFs) as well as associated infrastructure are being proposed on the Remaining Extent of the Farm Lyndoch 432 situated ~16km north of Kathu in the Northern Cape Province. The proposed SEFs fall within the jurisdiction of the Gamagara Local Municipality and within the greater John Taolo Gaetsewe District Municipality.

Each of the four (4) SEFs will be constructed as separate stand-alone projects, with a separate project development company (or Special Purpose Vehicle) as the applicant for each project. The projects are:

Project Name:	Applicant:
Hyperion Solar Development 1	Hyperion Solar Development 1 (Pty) Ltd
Hyperion Solar Development 2	Cyraguard (Pty) Ltd
Hyperion Solar Development 3	Nomispank (Pty) Ltd
Hyperion Solar Development 4	Nomispan (Pty) Ltd

This letter serves to inform you that the Scoping Reports (SRs) are available for Gamagara Local Municipality's review and written comments, and a CD containing the SRs is included in this envelope.

Please note that the SRs' review period is from **Friday, 26 October 2018** to **Monday, 26 November 2018** and we are looking forward receiving Gamagara Local Municipality's written comment on the SRs before or on the closing date of the review period.

Kind regards



Nicolene Venter
Public Participation and Social Consultant
Savannah Environmental



0861 223 224
www.dawnwing.co.za



1298110645

A member of the DHL Group

WAYBILL

FROM: SAVANNAH ENVIRO S A		Customer: CD		HAZARDOUS YES NO		Filing Ref: 2167	
Address: 1ST FLOOR BLOCK 2 5 WOODLANDS DRIVE WOODMEAD		PARCEL DETAILS		SERVICE (mark only one)			
City/District: WOODMEAD		No of Parcels: ①		Weight (kg): 40		Dimensions (cm): 30 x 1 x ①	
Postal Code: 2128		Special Code: 2128		Special Code: 2128		Special Code: 2128	
Sender Name: LISA		Sender Phone: 011 6563237		Special Code: 2128		Special Code: 2128	
TO: Gamasara Local Municipality		Dawn Wing reserves the right to mark the service "Overnight Express" should no service level be selected		SPECIAL INSTRUCTIONS			
Street Address (P.O. Box, Apartment, etc.): Civic Centre! Cnr Hendrick van Eck & Frikkie Meyer Road		Terms strictly 30 days from date of statement		To be selected (limited liability option for a maximum amount of R50 000 for non-registered parcels)			
City/District: Kathu		CASH AMOUNT R		PAID YES NO		Customer Value: ZAR	
Receiver Name: Thuseene Itumeene 053-723-600		Dawn Wing		Dawn Wing		Address to be Segregated: JB6925	
By signing this waybill the sender is consenting a selected service and warrants no authority to enter into the contract and to enter the goods, which contain dangerous goods, into the aircraft of the carrier's aeroplane.		Dawn Wing		Dawn Wing		Received in Good Order and Condition	
Sender Name: KATHU		Dawn Wing		Dawn Wing		Receiver's Signature: 	
Date: 2011/01/18		Dawn Wing		Dawn Wing		Print Name: Termy	
Signature: 		Dawn Wing		Dawn Wing		Date: 2011/01/18	

DAWN WING
A Division of DHL Lager Express Logistics (Pty) Ltd
Reg. No. 2006/0136307 VAT No. 4890221280
FSC No. 12209

*All weight and dimensions subject to verification through electronic weight and dimension machine (SABS calibrated)

PROOF OF DELIVERY

PROOF OF DELIVERY (Mandatory for all parcels) (SABS calibrated)

25 October 2018

Mr Disang Molaale
Municipal Manager
John Taolo Gaetsewe District Municipality
4 Federale Mynbou Street
KURUMAN 8460

Per Courier

Dear Mr Molaale,

**ENVIRONMENTAL IMPACT ASSESSMENT AND PUBLIC PARTICIPATION PROCESSES FOR THE PROPOSED
HYPERION SOLAR DEVELOPMENT 1, 2, 3 and 4 AND ASSOCIATED INFRASTRUCTURES NEAR KATHU,
NORTHERN CAPE PROVINCE**

NOTICE OF AVAILABILITY OF THE SCOPING REPORTS FOR REVIEW AND WRITTEN COMMENTS

The development of four (4) separate photovoltaic (PV) solar energy facilities (SEFs) as well as associated infrastructure are being proposed on the Remaining Extent of the Farm Lyndoch 432 situated ~16km north of Kathu in the Northern Cape Province. The proposed SEFs fall within the jurisdiction of the Gamagara Local Municipality and within the greater John Taolo Gaetsewe District Municipality.

Each of the four (4) SEFs will be constructed as separate stand-alone projects, with a separate project development company (or Special Purpose Vehicle) as the applicant for each project. The projects are:

Project Name:	Applicant:
Hyperion Solar Development 1	Hyperion Solar Development 1 (Pty) Ltd
Hyperion Solar Development 2	Cyraguard (Pty) Ltd
Hyperion Solar Development 3	Nomispank (Pty) Ltd
Hyperion Solar Development 4	Nomispan (Pty) Ltd

This letter serves to inform you that the Scoping Reports (SRs) are available for John Taolo Gaetsewe District Municipality's review and written comments, and a CD containing the SRs is included in this envelope.

Please note that the SRs' review period is from **Friday, 26 October 2018** to **Monday, 26 November 2018** and we are looking forward receiving Taolo Gaetsewe District Municipality's written comment on the SRs before or on the closing date of the review period.

Kind regards



Nicolene Venter
Public Participation and Social Consultant
Savannah Environmental

25 October 2018

Mr Tamai Hore
Senior Engineer: Generation Licensing
National Energy Regulator of South Africa
Kulawula House
526 Madiba Street
ARCADIA 0083

Per Courier

Dear Mr Hore,

**ENVIRONMENTAL IMPACT ASSESSMENT AND PUBLIC PARTICIPATION PROCESSES FOR THE PROPOSED
HYPERION SOLAR DEVELOPMENT 1, 2, 3 and 4 AND ASSOCIATED INFRASTRUCTURES NEAR KATHU,
NORTHERN CAPE PROVINCE**

NOTICE OF AVAILABILITY OF THE SCOPING REPORTS FOR REVIEW AND WRITTEN COMMENTS

The development of four (4) separate photovoltaic (PV) solar energy facilities (SEFs) as well as associated infrastructure are being proposed on the Remaining Extent of the Farm Lyndoch 432 situated ~16km north of Kathu in the Northern Cape Province. The proposed SEFs fall within the jurisdiction of the Gamagara Local Municipality and within the greater John Taolo Gaetsewe District Municipality.

Each of the four (4) SEFs will be constructed as separate stand-alone projects, with a separate project development company (or Special Purpose Vehicle) as the applicant for each project. The projects are:

Project Name:	Applicant:
Hyperion Solar Development 1	Hyperion Solar Development 1 (Pty) Ltd
Hyperion Solar Development 2	Cyraguard (Pty) Ltd
Hyperion Solar Development 3	Nomispan (Pty) Ltd
Hyperion Solar Development 4	Nomispan (Pty) Ltd

This letter serves to inform you that the Scoping Reports (SRs) are available for your Department's view and written comments, and a CD containing the SRs is included in this envelope.

Please note that the SRs' review period is from **Friday, 26 October 2018** to **Monday, 26 November 2018** and we are looking forward receiving your Department's written comment on the SRs before or on the closing date of the review period.

Kind regards



Nicolene Venter

Public Participation and Social Consultant
Savannah Environmental



0861 223 224
www.dawnwing.co.za



WAYBILL

Sender to complete yellow areas only

FROM: SAVANNAH ENVIRO S A		Contents CD		HAZARDOUS YES NO		Filing Ref: 2167	
Address 1ST FLOOR. BLOCK 2 5 WOODLANDS DRIVE WOODMEAD		PARCEL DETAILS No. of Parcels: ① Vol(kg)-T's & C's Apply* Mass(kg)-T's & C's Apply* 0.15 kg Dimensions (cm): 40, 30, 1		SERVICE (mark only one) Overnight Express <input checked="" type="checkbox"/> Economy Cargo <input type="checkbox"/> Domestic Road Freight <input type="checkbox"/> Sameday Express <input type="checkbox"/> International Documents <input type="checkbox"/> International Non Documents <input type="checkbox"/> International Air Freight <input type="checkbox"/> International Road Freight <input type="checkbox"/>			
City/Country WOODMEAD		Postal Code must be filled in 2128		SPECIAL INSTRUCTIONS Saturday Delivery Collection <input type="checkbox"/> Dawn Delivery (WFO) / Time Required <input type="checkbox"/> After Hours <input type="checkbox"/> Sunday / Public Holiday <input type="checkbox"/> Confirmation of Delivery <input type="checkbox"/>			
Senders Name LISA		Tel 011 6563237		Tick to select limited liability option (to a maximum amount of R50 000) for non-excluded articles <input type="checkbox"/>			
TO: National Energy Regulator of South Africa		Street Address (P.O. Box Addresses not accepted) Kulawula House! 526 Mediba Street		Customs Value ZAR <input type="text"/> Value of Article ZAR <input type="text"/>			
City/Country Arcadia		Postal Code must be filled in 20083		Account to be Debited JB6925			
Receiver's Name Tama Hore		Tel 019-036-9294		Sender's Ref. / Bag No. <input type="text"/>			
Andrew Timobhy		012-4014053		RECEIVED IN GOOD ORDER AND CONDITION			
By signing this waybill the sender is concluding a contract with Dawn Wing and warrants his authority to enter into this contract and to bind the entity, which he/she represents. The terms and conditions of this contract are contained on the reverse of the sender's copy.		Dawn Wing reserves the right to mark the service "Overnight Express" should no service level be selected		Receivers Signature: Betty			
Senders Name Georgina		Date 25.12.18		Collected By Courier MESA		Date 29/12/18	
Signature		Time		Time		Time: 10:43	
CASH AMOUNT R <input type="text"/>		PAID YES NO		Terms strictly 30 days from date of statement			
Special Instructions		PROOF OF DELIVERY		Date: 29/12/18 Time: 10:43			

DAWN WING
A Division of DPD Laser Express Logistics (Pty) Ltd
Reg. No. 2006/033353/07 VAT No. 4690235280
FSP NO 32009

*All weight and dimensions subject to verification through electronic weight and dimension machine (SABS calibrated)

25 October 2018

Mr Ratha Andrew Timothy
Senior Engineer: Generation Licensing
National Energy Regulator of South Africa
Kulawula House
526 Madiba Street
ARCADIA 0083

Per Courier

Dear Mr Timothy,

**ENVIRONMENTAL IMPACT ASSESSMENT AND PUBLIC PARTICIPATION PROCESSES FOR THE PROPOSED
HYPERION SOLAR DEVELOPMENT 1, 2, 3 and 4 AND ASSOCIATED INFRASTRUCTURES NEAR KATHU,
NORTHERN CAPE PROVINCE**

NOTICE OF AVAILABILITY OF THE SCOPING REPORTS FOR REVIEW AND WRITTEN COMMENTS

The development of four (4) separate photovoltaic (PV) solar energy facilities (SEFs) as well as associated infrastructure are being proposed on the Remaining Extent of the Farm Lyndoch 432 situated ~16km north of Kathu in the Northern Cape Province. The proposed SEFs fall within the jurisdiction of the Gamagara Local Municipality and within the greater John Taolo Gaetsewe District Municipality.

Each of the four (4) SEFs will be constructed as separate stand-alone projects, with a separate project development company (or Special Purpose Vehicle) as the applicant for each project. The projects are:

Project Name:	Applicant:
Hyperion Solar Development 1	Hyperion Solar Development 1 (Pty) Ltd
Hyperion Solar Development 2	Cyraguard (Pty) Ltd
Hyperion Solar Development 3	Nomispank (Pty) Ltd
Hyperion Solar Development 4	Nomispan (Pty) Ltd

This letter serves to inform you that the Scoping Reports (SRs) are available for your Organisation's view and written comments, and a CD containing the SRs is included in this envelope.

Please note that the SRs' review period is from **Friday, 26 October 2018** to **Monday, 26 November 2018** and we are looking forward receiving your Organisation's written comment on the SRs before or on the closing date of the review period.

Kind regards



Nicolene Venter
Public Participation and Social Consultant
Savannah Environmental



0861 223 224
www.dawnwing.co.za



WAYBILL

Sender to complete yellow areas only

FROM: SAVANNAH ENVIRO S A		Contents CD		HAZARDOUS YES NO		Filing Ref: 2167	
Address 1ST FLOOR. BLOCK 2 5 WOODLANDS DRIVE WOODMEAD		PARCEL DETAILS No. of Parcels: ① Vol(kg)-T's & C's Apply* Mass(kg)-T's & C's Apply* 0.15 kg Dimensions (cm): 40, 30, 1		SERVICE (mark only one) Overnight Express <input checked="" type="checkbox"/> Economy Cargo Domestic Road Freight Sameday Express International Documents International Non Documents International Air Freight International Road Freight			
City/Country: WOODMEAD Postal Code must be filled in: 2128		SPECIAL INSTRUCTIONS Saturday Delivery Collection Dawn Delivery 9100 / Time Required After Hours Sunday / Public Holiday Confirmation of Delivery		Tick to select limited liability option (to a maximum amount of R50 000) for non-excluded articles <input type="checkbox"/>			
Senders Name: LISA Tel: 011 6563237		TO: National Energy Regulator of South Africa		Customs Value ZAR		Value of Article ZAR	
Street Address (P.O. Box Addresses not accepted): Kulawula House! 526 Mediba Street		City/Country: Arcadia Postal Code must be filled in: 20033		Account to be Debited: JB6925			
Receiver's Name: Tama Hore Andrew Timothy		Tel: 019-036-9294 012-4014053		Sender's Ref. / Bag No.			
By signing this waybill the sender is concluding a contract with Dawn Wing and warrants his authority to enter into this contract and to bind the entity, which he/she represents. The terms and conditions of this contract are contained on the reverse of the sender's copy.		Dawn Wing reserves the right to mark the service "Overnight Express" should no service level be selected		RECEIVED IN GOOD ORDER AND CONDITION			
Senders Name: Georgia Date: 25.12.18 Time: 10:43		Collected By Courier: [Signature] Date: 25.12.18 Time: 10:43		CASH AMOUNT R [] PAID YES NO		Receivers Signature: [Signature]	
Signature: [Signature]		Special Instructions		Terms strictly 30 days from date of statement		Print Name: [Signature]	
Date: 25/12/18		Time: 10:43		Date: 25/12/18		Time: 10:43	

DAWN WING
A Division of DPD Laser Express Logistics (Pty) Ltd
Reg. No. 2006/033353/07 VAT No. 4690235280
FSP NO 32009

*All weight and dimensions subject to verification through electronic weight and dimension machine (SABS calibrated)

PROOF OF DELIVERY

25 October 2018

Mr Bryan Fisher
Director: Environmental Quality Management
Northern Cape Department of Environment and Nature Conservation
Sasko Building
90 Long Street
KIMBERLEY 8301

Per Courier

Dear Mr Fisher,

**ENVIRONMENTAL IMPACT ASSESSMENT AND PUBLIC PARTICIPATION PROCESSES FOR THE PROPOSED
HYPERION SOLAR DEVELOPMENT 1 AND ASSOCIATED INFRASTRUCTURES NEAR KATHU, NORTHERN
CAPE PROVINCE**

NOTICE OF AVAILABILITY OF THE SCOPING REPORT FOR REVIEW AND WRITTEN COMMENTS

Hyperion Solar Development 1 (Pty) Ltd, the developer, is proposing the development of the Hyperion Solar Photovoltaic (PV) 1 solar energy facility and associated infrastructure on the Remaining Extent of the Farm Lyndoch 432 situated ~16km north of Kathu in the Northern Cape Province. The proposed development falls within the jurisdiction of the Gamagara Local Municipality and within the greater John Taolo Gaetsewe District Municipality.

This letter serves to inform you that the Scoping Report (SR) is available for your Department's review and written comments, and a hard copy and CD containing the SR is included in this envelope.

Please note that the SR's review period is from **Friday, 26 October 2018** to **Monday, 26 November 2018** and we are looking forward receiving your Department's written comment on the SR before or on the closing date of the review period.

Kind regards



Nicolene Venter
Public Participation and Social Consultant
Savannah Environmental



a division of dpd LASER

0861 223 224
www.dawnwing.co.za



1298110693

WAYBILL

Sender to complete yellow areas only

FROM: SAVANNAH ENVIRO S A		Contents: Me. + CD		HAZARDOUS YES NO		Filing Ref: 2167	
Address: 1ST FLOOR. BLOCK 2 5 WOODLANDS DRIVE WOODMEAD		No. of Parcels: 1		Parcel Details: Vol/kg-T's & C's Apply: 7.85kg		SERVICE (mark only one)	
City/Country: WOODMEAD		Postal Code: 2128		Dimensions (cm): 20 30 10		<input checked="" type="checkbox"/> Express <input type="checkbox"/> Economy <input type="checkbox"/> International Documents <input type="checkbox"/> International Non-Documents <input type="checkbox"/> International Air Freight <input type="checkbox"/> International Road Freight	
Senders Name: LISA		Phone: 011 6563237		Special Instructions: POD		<input type="checkbox"/> Tick to select limited liability option (to a maximum amount of R50 000) for non-excluded articles Customs Value ZAR: _____ Value of Article ZAR: _____ Account to be Debited: JB6925 Sender's Ref / Bag No: _____	
TO: Department of Environment and Nature Conservation, SASTA Building, 90 Lang Street		City/Country: Kimberley		Postal Code: 8301		RECEIVED IN GOOD ORDER AND CONDITION Receiver's Signature: Print Name: Ryle Date: 21/01/18 Time: 10:25	
Receiver's Name: Mr Bryan Fisher		Phone: 083 270 8323		Terms strictly 30 days from date of statement CASH AMOUNT R _____ PAID YES NO		PROOF OF DELIVERY	
By signing this waybill the sender is concluding a contract with Dawn Wing and warrants his authority to enter into this contract and to bind the entity, which he/she represents. The terms and conditions of this contract are contained on the reverse of the sender's copy.		Senders Name:		Date: 25-12-18		Collected By Courier:	
Signature:		Date: 26/1/18		Time: _____		Specify instructions: _____	

DAWN WING

A Division of DPD Laser Express Logistics (Pty) Ltd
Reg. No. 2006/033352/07 VAT No. 4690735280
FSP NO 32029

*All weight and dimensions subject to verification through electronic weight and dimension machine (SABS calibrated)

25 October 2018

Ms Samantha De la Fontaine
Production Scientists Grade A: District Ecologist
Department of Environment and Nature Conservation: Northern Cape
1st Floor, Provincial Building
Cnr Rivier & Nelson Mandela Roads
UPINGTON 8800

Per Courier

Dear Ms De la Fontaine,

**ENVIRONMENTAL IMPACT ASSESSMENT AND PUBLIC PARTICIPATION PROCESSES FOR THE PROPOSED
HYPERION SOLAR DEVELOPMENT 1, 2, 3 and 4 AND ASSOCIATED INFRASTRUCTURES NEAR KATHU,
NORTHERN CAPE PROVINCE**

NOTICE OF AVAILABILITY OF THE SCOPING REPORTS FOR REVIEW AND WRITTEN COMMENTS

The development of four (4) separate photovoltaic (PV) solar energy facilities (SEFs) as well as associated infrastructure are being proposed on the Remaining Extent of the Farm Lyndoch 432 situated ~16km north of Kathu in the Northern Cape Province. The proposed SEFs fall within the jurisdiction of the Gamagara Local Municipality and within the greater John Taolo Gaetsewe District Municipality.

Each of the four (4) SEFs will be constructed as separate stand-alone projects, with a separate project development company (or Special Purpose Vehicle) as the applicant for each project. The projects are:

Project Name:	Applicant:
Hyperion Solar Development 1	Hyperion Solar Development 1 (Pty) Ltd
Hyperion Solar Development 2	Cyraguard (Pty) Ltd
Hyperion Solar Development 3	Nomispank (Pty) Ltd
Hyperion Solar Development 4	Nomispan (Pty) Ltd

This letter serves to inform you that the Scoping Reports (SRs) are available for your Department's review and written comments, and a CD containing the SRs is included in this envelope.

Please note that the SRs' review period is from **Friday, 26 October 2018 to Monday, 26 November 2018** and we are looking forward receiving your Department's written comment on the SRs before or on the closing date of the review period.

Kind regards



Nicolene Venter
Public Participation and Social Consultant
Savannah Environmental



0861 223 224
www.dawnwing.co.za



WAYBILL

Sender to complete yellow areas only

FROM: SAVANNAH ENVIRO S A Address: 1ST FLOOR, BLOCK 2 5 WOODLANDS DRIVE WOODMEAD City/County: WOODMEAD Post Code: 2128 Tel/Fax No: 011 6563237 Recipient Name: LISA		HAZARDOUS YES NO No. of Parcels: 1 Weight: 40 Dimensions: 30 x 1 x 1 Parcel Details: (Handwritten: 40 30 1)		Filing Ref: 2167 SERVICE (mark only one) <input checked="" type="checkbox"/> Standard <input type="checkbox"/> Express <input type="checkbox"/> Next Day <input type="checkbox"/> Next Business Day <input type="checkbox"/> Next Morning <input type="checkbox"/> Next Afternoon <input type="checkbox"/> Next Evening <input type="checkbox"/> Next Weekend <input type="checkbox"/> Next Holiday	
TO: Department of Environment and Nature Conservation; 1st Floor, Provincial Building, eny Rivier & Nelson Mandela Roads City/County: 8800 Receiver's Name: Ms Neda Fontaine 012-862-5678 Signature: (Handwritten) Date: 25-10-18 Time: 14:00 Collected by Courier: (Handwritten) Date: 24/10/18		Dawn Wing reserves the right to mark the service "Overnight Express" should no service level be selected. Terms strictly 30 days from date of statement CASH AMOUNT R PAID YES NO Special instructions:		SPECIAL INSTRUCTIONS Take the weight of items of liability online (for a maximum amount of R50 000) for non-excluded articles. Customer value: R25 Value of article: R25 Account No for Delivery: JB6925 Sender's Ref: Bag No.	
DAWN WING A Division of DPD Laser Express Logistics (Pty) Ltd Reg. No. 2005/033353/07 VAT No. 4920274280 FSP NO 24004		*All weight and dimensions subject to verification through electronic weight and dimension machine (SABS calibrated)		PROOF OF DELIVERY Receiver's Signature: (Handwritten) Print Name: S. V. H. WEST HILL Date: 25/10/18 Time: 14:00	

25 October 2018

Mr Jaco Roelofse
Director: Roads
Department of Roads and Public Works
45 Schmidtsdrift Road
KIMBERLEY 8301

Per Courier

Dear Mr Roelofse,

**ENVIRONMENTAL IMPACT ASSESSMENT AND PUBLIC PARTICIPATION PROCESSES FOR THE PROPOSED
HYPERION SOLAR DEVELOPMENT 1, 2, 3 and 4 AND ASSOCIATED INFRASTRUCTURES NEAR KATHU,
NORTHERN CAPE PROVINCE**

NOTICE OF AVAILABILITY OF THE SCOPING REPORTS FOR REVIEW AND WRITTEN COMMENTS

The development of four (4) separate photovoltaic (PV) solar energy facilities (SEFs) as well as associated infrastructure are being proposed on the Remaining Extent of the Farm Lyndoch 432 situated ~16km north of Kathu in the Northern Cape Province. The proposed SEFs fall within the jurisdiction of the Gamagara Local Municipality and within the greater John Taolo Gaetsewe District Municipality.

Each of the four (4) SEFs will be constructed as separate stand-alone projects, with a separate project development company (or Special Purpose Vehicle) as the applicant for each project. The projects are:

Project Name:	Applicant:
Hyperion Solar Development 1	Hyperion Solar Development 1 (Pty) Ltd
Hyperion Solar Development 2	Cyraguard (Pty) Ltd
Hyperion Solar Development 3	Nomispank (Pty) Ltd
Hyperion Solar Development 4	Nomispan (Pty) Ltd

This letter serves to inform you that the Scoping Reports (SRs) are available for your Department's review and written comments, and a CD containing the SRs is included in this envelope.

Please note that the SRs' review period is from **Friday, 26 October 2018** to **Monday, 26 November 2018** and we are looking forward receiving your Department's written comment on the SRs before or on the closing date of the review period.

Kind regards



Nicolene Venter
Public Participation and Social Consultant
Savannah Environmental



a division of DPD LASER

0861 223 224

www.dawnwing.co.za



1298110586

WAYBILL

Sender to complete yellow areas only

FROM: SAVANNAH ENVIRO S A		Contents: CD		HAZARDOUS YES NO		Filing Ref: 2167	
Address: 1ST FLOOR, BLOCK 2 5 WOODLANDS DRIVE WOODMEAD		No. of Parcels: 1		Dimensions (cm): 40 30 1		PARCEL DETAILS	
City/Country: WOODMEAD		Postal Code: 2128		Message: Ts & Cs Apply		SERVICE (mark only one)	
Sender's Name: LISA		Phone: 011 6563237		International Documents		Domestic Road Freight	
TO: Department of Roads and public work: 45 SCHMIDTSCH FE ROAD		City/Country: Kimberley		Postal Code: 8301		International Air Freight	
Receiver's Name: Mr Jacob Roeloffse		Phone: 076-911-6206		Special Instructions: Dawn Wing reserves the right to mark the service "Overnight Express" should no service level be selected		SPECIAL INSTRUCTIONS	
By signing this waybill the sender is concluding a contract with Dawn Wing and warrants his authority to enter into this contract and to bind the entity, which hereby represents. The terms and conditions of this contract are contained on the reverse of the sender's copy.		Signature: [Signature]		Date: 26/11/15		Tick to select limited liability option (to a maximum amount of R50 000) for non-excluded articles: <input type="checkbox"/>	
Sender's Name: [Signature]		Date: 26/11/15		CASH AMOUNT R		PAID YES NO	
Signature: [Signature]		Date: 26/11/15		Terms strictly 30 days from date of statement		Account to be Debited: JB6925	
Signature: [Signature]		Date: 26/11/15		Dawn Wing reserves the right to mark the service "Overnight Express" should no service level be selected		Sender's Ref / Bag No:	
Signature: [Signature]		Date: 26/11/15		Terms strictly 30 days from date of statement		RECEIVED IN GOOD ORDER AND CONDITION	
Signature: [Signature]		Date: 26/11/15		CASH AMOUNT R		Receiver's Signature: [Signature]	
Signature: [Signature]		Date: 26/11/15		PAID YES NO		Print Name: [Signature]	
Signature: [Signature]		Date: 26/11/15		Special Instructions:		Date: _____ Time: 10h15	

DAWN WING

A Division of DPD Laser Express Logistics (Pty) Ltd
Reg. No. 2906-03353/07 VAT No. 4690235280
FSP NO 32009

*All weight and dimensions subject to verification through electronic weight and dimension machine (SABS calibrated)

PROOF OF DELIVERY

25 October 2018

Lieutenant Colonel Keasenosi Zondi
SO1 Military Integrated Environment Management
South African Defence Force
Armcor Building
Block 5, Level 4
Cnr Delmas Avenue & Nossob Streets
Erasmuskloof
PRETORIA 0001

Per Courier

Dear Lieutenant Colonel Zondi,

**ENVIRONMENTAL IMPACT ASSESSMENT AND PUBLIC PARTICIPATION PROCESSES FOR THE PROPOSED
HYPERION SOLAR DEVELOPMENT 1, 2, 3 and 4 AND ASSOCIATED INFRASTRUCTURES NEAR KATHU,
NORTHERN CAPE PROVINCE**

NOTICE OF AVAILABILITY OF THE SCOPING REPORTS FOR REVIEW AND WRITTEN COMMENTS

The development of four (4) separate photovoltaic (PV) solar energy facilities (SEFs) as well as associated infrastructure are being proposed on the Remaining Extent of the Farm Lyndoch 432 situated ~16km north of Kathu in the Northern Cape Province. The proposed SEFs fall within the jurisdiction of the Gamagara Local Municipality and within the greater John Taolo Gaetsewe District Municipality.

Each of the four (4) SEFs will be constructed as separate stand-alone projects, with a separate project development company (or Special Purpose Vehicle) as the applicant for each project. The projects are:

Project Name:	Applicant:
Hyperion Solar Development 1	Hyperion Solar Development 1 (Pty) Ltd
Hyperion Solar Development 2	Cyraguard (Pty) Ltd
Hyperion Solar Development 3	Nomispank (Pty) Ltd
Hyperion Solar Development 4	Nomispan (Pty) Ltd

This letter serves to inform you that the Scoping Reports (SRs) are available for your Department's review and written comments, and a CD containing the SRs is included in this envelope.

Please note that the SRs' review period is from **Friday, 26 October 2018** to **Monday, 26 November 2018** and we are looking forward receiving your Department's written comment on the SRs before or on the closing date of the review period.

Kind regards



Nicolene Venter
Public Participation and Social Consultant
Savannah Environmental



global express

a division of dpd LASER

0861 223 224

www.dawnwing.co.za

WAYBILL



1298110623

Sender to complete yellow areas only

FROM: SAVANNAH ENVIRO S A		Contents: CD		HAZARDOUS YES NO		Filing Ref: 2 67	
Address: 1ST FLOOR. BLOCK 2 5 WOODLANDS DRIVE WOODMEAD		No. of Parcels: 1		Vol(kg)-T's & C's Apply*		PARCEL DETAILS	
City/Country: WOODMEAD		Postal Code: 2128		Dimensions (cm): 40 30 1		Mass(kg)-T's & C's Apply* 0.05kg	
Senders Name: LISA		Phone: 011 6563237		Special Instructions: <input checked="" type="checkbox"/> Overnight Express		SERVICE (mark only one)	
TO: 501 Millbary Integrated Group Management Services Dept Ce Force: Fimscar Building Block 5, Level 4. Cnr Dumas Avenue & Mossab Streets. GRASMUSKLOOF		City/Country: Pieteria		Postal Code: 0001		International Documents: <input checked="" type="checkbox"/>	
Receiver's Name: Koosenos Zondi		Phone: 065-306-7985		Dawn Wing reserves the right to mark the service "Overnight Express" should no service level be selected		International Road Freight: <input type="checkbox"/>	
By signing this waybill the sender is concluding a contract with Dawn Wing and warrants his authority to enter into this contract and to bind the entity, which he/she represents. The terms and conditions of this contract are contained on the reverse of the sender's copy.		Date: 25-10-18		Time: 13:05		Special Instructions: Terms strictly 30 days from date of statement	
Senders Name: Koosenos Zondi		Date: 25-10-18		Time: 13:05		CASH AMOUNT: R	
Signature: [Signature]		Date: 25-10-18		Time: 13:05		PAID YES NO	
Signature: [Signature]		Date: 25-10-18		Time: 13:05		Special Instructions: Dawn Wing reserves the right to mark the service "Overnight Express" should no service level be selected	

RECEIVED IN GOOD ORDER AND CONDITION

Receiver's Signature: [Signature]
Print Name: H.K. ZONDI

Date: 03/11/18 Time: 13:05

PROOF OF DELIVERY

DAWN WING
A Division of DPD Laser Express Logistics (Pty) Ltd
Reg. No. 2006/033353/07 VAT No. 469235280
FSP NO 32009

*All weight and dimensions subject to verification through electronic weight and dimension machine (SABS calibrated)

25 October 2018

Ms Nicole Abrahams
Environmental Co-ordinator: Western Region
SA National Roads Agency Ltd
1 Havenga Street
Oakdale
BELLEVILLE 7530

Per Courier

Dear Ms Abrahams,

**ENVIRONMENTAL IMPACT ASSESSMENT AND PUBLIC PARTICIPATION PROCESSES FOR THE PROPOSED
HYPERION SOLAR DEVELOPMENT 1 AND ASSOCIATED INFRASTRUCTURES NEAR KATHU, NORTHERN
CAPE PROVINCE**

NOTICE OF AVAILABILITY OF THE SCOPING REPORT FOR REVIEW AND WRITTEN COMMENTS

Hyperion Solar Development 1 (Pty) Ltd, the developer, is proposing the development of the Hyperion Solar Photovoltaic (PV) 1 solar energy facility and associated infrastructure on the Remaining Extent of the Farm Lyndoch 432 situated ~16km north of Kathu in the Northern Cape Province. The proposed development falls within the jurisdiction of the Gamagara Local Municipality and within the greater John Taolo Gaetsewe District Municipality.

This letter serves to inform you that the Scoping Report (SR) is available for your Department's review and written comments, and a hard copy and CD containing the SR is included in this envelope.

Please note that the SR's review period is from **Friday, 26 October 2018** to **Monday, 26 November 2018** and we are looking forward receiving your Department's written comment on the SR before or on the closing date of the review period.

Kind regards



Nicolene Venter

**Public Participation and Social Consultant
Savannah Environmental**



0861 223 224

www.dawnwing.co.za



1298110682

WAYBILL

Sender to complete yellow areas only

FROM: SAVANNAH ENVIRO S A		Contents HG + CD		HAZARDOUS YES NO <small>IF YES, SEE REVERSE</small>		Filing Ref: 2167	
Address 1ST FLOOR. BLOCK 2 5 WOODLANDS DRIVE WOODMEAD		PARCEL DETAILS		SERVICE (mark only one)			
City/Country WOODMEAD		Postal Code must be filled in 2128		No. of Parcels 1	Vol(kg)-T's & C's Apply	Mass(kg)-T's & C's Apply	Overnight Express
Senders Name LISA		011 6563237		Dimensions (cm) 40 30 1		Economy Cargo	
TO: SA National Roads Agency		Street Address (P.O. Box Addresses not accepted) Lbd! 1 Havenga Street Oakdale		Dawn Wing reserves the right to mark the service "Overnight Express" should no service level be selected		Domestic Road Freight	
City/Country Bellville		Postal Code must be filled in 7530		Terms strictly 30 days from date of statement		Saturday Delivery Collection	
Receiver's Name Nicole Abrahams		081-957-6602		CASH AMOUNT R		International Documents	
By signing this waybill the sender is concluding a contract with Dawn Wing and warrants his authority to enter into this contract and to bind the entity, which he/she represents. The terms and conditions of this contract are contained on the reverse of the sender's copy.		Special Instructions		PAID YES NO		International Non Documents	
Senders Name Georgina		Date 25-10-18		Collected By Counter PASA		International Air Freight	
Signature [Signature]		Time		Date 26/10/18		International Road Freight	
						SPECIAL INSTRUCTIONS	
						Saturday Delivery 9:00 / Time Required	
						After Hours	
						Sunday / Public Holiday	
						Confirmation of Delivery	
						Tick to select limited liability option (to a maximum amount of R50 000) for non-excluded articles	
						Customs Value ZAR	
						Value of Article ZAR	
						Account to be Debited JB6925	
						Sender's Ref. / Bag No.	
						RECEIVED IN GOOD ORDER AND CONDITION	
						Receiver's Signature [Signature]	
						Print Name: [Signature]	
						Date: 29/10/18 Time: 8:10	

DAWN WING

A Division of DPD Laser Express Logistics (Pty) Ltd
Reg. No. 2006/039353/07 VAT No. 4690235280
FSP NO 32009

*All weight and dimensions subject to verification through electronic weight and dimension machine (SABS calibrated)

PROOF OF DELIVERY



25 October 2018

Dr Adriaan Tiplady
Manager: Site Categorisation
Square Kilometre Array
1st Floor
17 Baker Street
ROSEBANK 2196

Per Courier

Dear Dr Tiplady,

**ENVIRONMENTAL IMPACT ASSESSMENT AND PUBLIC PARTICIPATION PROCESSES FOR THE PROPOSED
HYPERION SOLAR DEVELOPMENT 1, 2, 3 and 4 AND ASSOCIATED INFRASTRUCTURES NEAR KATHU,
NORTHERN CAPE PROVINCE**

NOTICE OF AVAILABILITY OF THE SCOPING REPORTS FOR REVIEW AND WRITTEN COMMENTS

The development of four (4) separate photovoltaic (PV) solar energy facilities (SEFs) as well as associated infrastructure are being proposed on the Remaining Extent of the Farm Lyndoch 432 situated ~16km north of Kathu in the Northern Cape Province. The proposed SEFs fall within the jurisdiction of the Gamagara Local Municipality and within the greater John Taolo Gaetsewe District Municipality.

Each of the four (4) SEFs will be constructed as separate stand-alone projects, with a separate project development company (or Special Purpose Vehicle) as the applicant for each project. The projects are:

Project Name:	Applicant:
Hyperion Solar Development 1	Hyperion Solar Development 1 (Pty) Ltd
Hyperion Solar Development 2	Cyraguard (Pty) Ltd
Hyperion Solar Development 3	Nomispark (Pty) Ltd
Hyperion Solar Development 4	Nomispan (Pty) Ltd

This letter serves to inform you that the Scoping Reports (SRs) are available for your Department's review and written comments, and a CD containing the SRs, are included in this envelope.

Please note that the SRs' review period is from **Friday, 26 October 2018** to **Monday, 26 November 2018** and we are looking forward receiving your Department's written comment on the SRs before or on the closing date of the review period.

Kind regards



Nicolene Venter
Public Participation and Social Consultant
Savannah Environmental



0861 223 224
www.dawnwing.co.za



1298110531

WAYBILL

Sender to complete yellow areas only

FROM: SAVANNAH ENVIRO S A		Contents: CD		HAZARDOUS YES NO		Filing Ref: 2167	
Address: 1ST FLOOR. BLOCK 2 5 WOODLANDS DRIVE WOODMEAD		PARCEL DETAILS		SERVICE (mark only one)			
City/Country: WOODMEAD		No. of Parcels: 1		Vol(kg)-T's & C's Apply: 0.105kg		Overnight Express: <input checked="" type="checkbox"/>	
Postal Code: 2128		Dimensions (cm): 40 x 30 x 7		Mass(kg)-T's & C's Apply: 0.105kg		Economy Cargo: <input type="checkbox"/>	
Senders Name: LISA		Phone: 011 6563237		International Documents: <input type="checkbox"/>		Domestic Road Freight: <input type="checkbox"/>	
TO: Manager Site Categorisation		Street Address: Square Kilometre Amay 156 Floor 17 Baker Street		International Non Documents: <input type="checkbox"/>		International Air Freight: <input type="checkbox"/>	
City/Country: Rosebank		Postal Code: 2196		Special Instructions: PAID		Saturday Delivery Collection: <input type="checkbox"/>	
Receiver's Name: Dr Advigan Updey		Phone: 012-372-0134		Dawn Wing reserves the right to mark the service "Overnight Express" should no service level be selected		After Hours: <input type="checkbox"/>	
By signing this waybill the sender is concluding a contract with Dawn Wing and warrants his authority to enter into this contract and to bind the entity, which he/she represents. The terms and conditions of this contract are contained on the reverse of the sender's copy.		Terms strictly 30 days from date of statement		CASH AMOUNT: R		Sunday / Public Holiday: <input type="checkbox"/>	
Senders Name: Georgeina		Date: 25-10-18		PAID YES NO		Confirmation of Delivery: <input type="checkbox"/>	
Signature: [Signature]		Collected By Counter: [Signature]		Special Instructions:		Tick to select limited liability option (to a maximum amount of R50 000) for non-excluded articles: <input type="checkbox"/>	
Time: [Time]		Date: 26/10/18		Time: [Time]		Customs Value ZAR: [Value]	
Time: [Time]		Date: [Date]		Time: [Time]		Value of Article ZAR: [Value]	
Time: [Time]		Date: [Date]		Time: [Time]		Account to be Debited: JB6925	
Time: [Time]		Date: [Date]		Time: [Time]		Sender's Ref. / Bag No.:	
Time: [Time]		Date: [Date]		Time: [Time]		RECEIVED IN GOOD ORDER AND CONDITION	
Time: [Time]		Date: [Date]		Time: [Time]		Receivers Signature: [Signature]	
Time: [Time]		Date: [Date]		Time: [Time]		Print Name: Lizzy	
Time: [Time]		Date: [Date]		Time: [Time]		Date: 29/10/18 Time: 9:20	

DAWN WING

A Division of DPD Laser Express Logistics (Pty) Ltd
Reg. No. 2006/033353/07 VAT No. 4690235280
FSP NO 32009

*All weight and dimensions subject to verification through electronic weight and dimension machine (SABS calibrated)

PROOF OF DELIVERY

CORRESPONDENCE AFTER NOTIFICATION OF
SCOPING REPORT FOR PUBLIC REVIEW AND
COMMENT

Rozanne Els

From: Rozanne Els <rozanne@savannahsa.com>
Sent: 05 November 2018 7:46 AM
To: 'bitsangk@gamagara.gov.za'
Subject: FW: Focus Group Meeting Hyperion solar PV facilities

Importance: High

Good day Lebo,

Please could you urgently respond to my emails below to secure the meeting.

Thank you and kind regards,

Rozanne Els

Public Participation Co-ordinator | Savannah Environmental (Pty) Ltd
Tel: +27 (0)11 656 3237 | Fax: +27 (0)86 684 0547

[SAWEA Award for Leading Environmental Consultant for Wind Projects in 2013 & 2015](#)

From: Rozanne Els [mailto:rozanne@savannahsa.com]
Sent: 02 November 2018 9:00 AM
To: 'bitsangk@gamagara.gov.za' <bitsangk@gamagara.gov.za>
Subject: Focus Group Meeting Hyperion solar PV facilities
Importance: High

Dear Lebo,

The emails below has reference,

I have been trying to call you, but seems that I cannot get hold of you.

Please could you let me know if the meeting will be possible and provide feedback as per emails below ?

Thank you for your assistance.

Kind regards,

Rozanne Els

Public Participation Co-ordinator | Savannah Environmental (Pty) Ltd
Tel: +27 (0)11 656 3237 | Fax: +27 (0)86 684 0547

[SAWEA Award for Leading Environmental Consultant for Wind Projects in 2013 & 2015](#)

From: Rozanne Els [mailto:rozanne@savannahsa.com]
Sent: 01 November 2018 11:03 AM
To: 'bitsangk@gamagara.gov.za' <bitsangk@gamagara.gov.za>
Subject: Focus Group Meeting Hyperion solar PV facilities
Importance: High

Good day Lebo,

Do you have any feedback on the email below yet ?

Kind regards,

Rozanne Els

Public Participation Co-ordinator | Savannah Environmental (Pty) Ltd

Tel: +27 (0)11 656 3237 | Fax: +27 (0)86 684 0547

[SAWEA Award for Leading Environmental Consultant for Wind Projects in 2013 & 2015](#)

From: Rozanne Els [<mailto:rozanne@savannahsa.com>]

Sent: 31 October 2018 12:15 PM

To: 'bitsangk@gamagara.gov.za' <bitsangk@gamagara.gov.za>

Subject: Focus Group Meeting Hyperion solar PV facilities

Importance: High

Dear Lebo,

I recall our earlier conversation per telephone.

We would like to arrange a meeting with the Municipal manager and other officials on the 9th of November 2018 at 09h00. Kindly confirm if this will be suitable ? Also if you could please arrange for the venue to take place at the Municipalities boardroom/chambers.

I will send a formal invitation with all the information by the end of the week.

Also, please could you provide me with your details so that I can update the project database ? we have the Municipal Manager's secretary as Ingrid de Koker.

Name:

Surname:

Designation:

Tel:

Cell:

Email Address:

Physical Address:

Also if you could confirm that the Municipal Manager's details that we have is correct:

Thusoeng Itumeleng

Municipal Manager

Tel: 053 723 6000

Email: clementi@gamagara.gov.za

Thank you and kind regards,

Rozanne Els

From: Nicolene Venter <nicolene@savannahsa.com>
Sent: 20 November 2018 7:35 AM
To: 'Msimango Philani (KBY)'
Cc: 'Rozanne Els'; 'Thalita Botha'
Subject: RE: Reminder: Hyperion Solar Notification of Availability of Scoping Report for public review

Dear Mr Msimango,

Thank you for the confirmation of receipt of the four (4) Scoping Reports by the Water Quality Management at DWS: Northern Cape Province.

We are looking forward to the Assessors' comments.

Kind regards,

Nicolene Venter

Public Participation & Social Consultant | Savannah Environmental (Pty) Ltd
Tel: +27 (0)11 656 3237 | Fax: +27 (0)86 684 0547

[SAWEA Award for Leading Environmental Consultant for Wind Projects in 2013 & 2015](#)

From: Msimango Philani (KBY) <Msimangop@dws.gov.za>
Sent: Tuesday, November 20, 2018 7:22 AM
To: Nicolene Venter <nicolene@savannahsa.com>
Cc: 'Rozanne Els' <rozanne@savannahsa.com>; 'Thalita Botha' <thalita@savannahsa.com>
Subject: RE: Reminder: Hyperion Solar Notification of Availability of Scoping Report for public review

Good Day

Kindly take note that the reports have been received by Water Quality Management on the 19th of November 2018 for four separate projects and each have been assigned to an assessor. The assessor will contact you once the reports have been assessed.

Also please take note that my surname is **Msimango** and not "Msimanga". I would appreciate it if you could address me accordingly next time.

Regards

Mr. Philani P. Msimango

BSc - Geological Sciences (UKZN); **BSc Hons - Geohydrology** (UFS-IGS)

Control Scientific Technician

Water Quality Management - Lower Vaal

Northern Cape Provincial Operations

E: msimangop@dws.gov.za

T: +27 53 836 7649

Private Bag X6101 | 28 Central Road | Beaconsfield | Kimberley | 8301

"The man that once did sell the lion's skin, While the beast lived was killed with hunting him" - William Shakespeare



From: Nicolene Venter [<mailto:nicolene@savannahsa.com>]
Sent: Friday, November 16, 2018 4:00 PM
To: Msimango Philani (KBY)
Cc: 'Rozanne Els'; 'Thalita Botha'
Subject: RE: Reminder: Hyperion Solar Notification of Availability of Scoping Report for public review

Dear Mr Msimanga,

I can confirm that I discussed the distribution of Environmental Impact Assessment and Basic Assessment Reports to the Department of Water and Sanitation (DWS): Northern Cape Province, with Mr Abe Abrahams.

It was confirmed that all Reports must please be addressed and sent to his Office and from there he will allocate it to the relevant DWS Case Officer and should DWS National needs a copy, he will send it to them.

I will be in contact with Mr Abrahams' Office on Monday to follow-up on the matter and will revert to you soon thereafter.

Kind regards,

Nicolene Venter

Public Participation & Social Consultant | Savannah Environmental (Pty) Ltd
Tel: +27 (0)11 656 3237 | Fax: +27 (0)86 684 0547

[SAWEA Award for Leading Environmental Consultant for Wind Projects in 2013 & 2015](#)

From: Msimango Philani (KBY) <MsimangoP@dws.gov.za>
Sent: Friday, November 16, 2018 1:56 PM
To: Savannah Environmental Public Process <publicprocess@savannahsa.com>
Cc: 'Nicolene Venter' <nicolene@savannahsa.com>
Subject: RE: Reminder: Hyperion Solar Notification of Availability of Scoping Report for public review

Good Day

Thank you for the response. Do you not receive an acknowledgement that it is being sent/delivered because normally we receive a notification stating that the email has been delivered to the recipient.

I will follow up with IT because there is no record of such an email at my disposal and I do not remember reading such an email. Also there is no records of the Reports being submitted to Water Quality Management but I will follow up with Registry, perhaps its an administrative error.

Regards

Mr. Philani P. Msimango

BSc - Geological Sciences (UKZN); **BSc Hons - Geohydrology** (UFS-IGS)

Control Scientific Technician

Water Quality Management - Lower Vaal

Northern Cape Provincial Operations

E: msimangop@dws.gov.za

T: +27 53 836 7649



From: Savannah Environmental Public Process [<mailto:publicprocess@savannahsa.com>]
Sent: Friday, November 16, 2018 1:50 PM
To: Msimango Philani (KBY)
Cc: 'Nicolene Venter'
Subject: Reminder: Hyperion Solar Notification of Availability of Scoping Report for public review

Good day,

Thank you for your email.

Please see attached the Proof of Email that the initial email was sent to you.

Kindly note that a CD and a Hard Copy was sent to the Department to Mr Abe Abrahams.
Waybill No.:1298110704

Kind regards,

Rozanne Els

Public Participation Co-ordinator | Savannah Environmental (Pty) Ltd
Tel: +27 (0)11 656 3237 | Fax: +27 (0)86 684 0547

[SAWEA Award for Leading Environmental Consultant for Wind Projects in 2013 & 2015](#)

From: Msimango Philani (KBY) [<mailto:MsimangoP@dws.gov.za>]
Sent: 16 November 2018 9:58 AM
To: Savannah Public Process <publicprocess@savannahsa.com>
Cc: nicolene@savannahsa.com
Subject: RE: Reminder: Hyperion Solar Notification of Availability of Scoping Report for public review

Good Day

I do not recall receiving the initial email and I have no record of this email.
Can you please verify with your records if indeed I did receive the initial email? Please send that verification to me so I can follow up with our IT Department as I have no records of this.

Also please forward the hardcopy or cd of the impact assessment so it can be sent to an assessor to assess.

The address is as follows:

28 Central Road
Beaconsfield
Kimberley
8301
Attention: Water Quality Management

Regards

Mr. Philani P. Msimango
BSc - Geological Sciences (UKZN); **BSc Hons - Geohydrology** (UFS-IGS)
Control Scientific Technician
Water Quality Management - Lower Vaal
Northern Cape Provincial Operations
E: msimangop@dws.gov.za
T: +27 53 836 7649

Private Bag X6101 | 28 Central Road | Beaconsfield | Kimberley | 8301

"The man that once did sell the lion's skin, While the beast lived was killed with hunting him" - William Shakespeare



From: Savannah Public Process [<mailto:publicprocess@savannahsa.com>]
Sent: Friday, November 16, 2018 9:47 AM
Cc: nicolene@savannahsa.com
Subject: Reminder: Hyperion Solar Notification of Availability of Scoping Report for public review

Dear Stakeholder,

With reference to the attached notification letter and email below, this email serves as a reminder that the comment period ends on **Monday, 26 November 2018**.

Kindly submit your comments on or before **Monday, 26 November 2018** by close of business.

Thank you and kind regards,

Rozanne Els

Public Participation Co-ordinator | Savannah Environmental (Pty) Ltd
Tel: +27 (0)11 656 3237 | Fax: +27 (0)86 684 0547

SAWEA Award for Leading Environmental Consultant for Wind Projects in 2013 & 2015

> From: Savannah Public Process <publicprocess@savannahsa.com>
> Date Sent: 26/10/2018 13:13
> To:
> Cc:
> Subject: FW: Hyperion Solar Notification of Availability of Scoping Report for public review
>

Dear Stakeholder,

The development of four (4) separate photovoltaic (PV) solar energy facilities (SEFs) as well as associated infrastructure are being proposed on the Remaining Extent of the Farm Lyndoch 432 situated ~16km north of Kathu in the Northern Cape Province. The proposed SEFs fall within the jurisdiction of the Gamagara Local Municipality and within the greater John Taolo Gaetsewe District Municipality. These facilities will be called Hyperion Solar Development 1, 2, 3 and 4.

As a registered Interested and Affected Party (I&AP), you are hereby notified that the Scoping Report is available for review and comment. The report can be viewed at the Kathu Public Library (1 Hendrik van Eck Road, Kathu, Northern Cape Province) from **Friday, 26 October 2018 to Monday, 26 November 2018**. The report can also be downloaded from the following website: www.savannahsa.com. A password to access the downloads page can be requested from the contact person below.

Please refer to the attached notification letter for further information.

Kind regards,

Rozanne Els

Public Participation Co-ordinator | Savannah Environmental (Pty) Ltd
Tel: +27 (0)11 656 3237 | Fax: +27 (0)86 684 0547

SAWEA Award for Leading Environmental Consultant for Wind Projects in 2013 & 2015

DISCLAIMER: This message and any attachments are confidential and intended solely for the addressee. If you have received this message in error, please notify the system manager/sender. Any unauthorized use, alteration or dissemination is prohibited. The Department of Water and Sanitation further accepts no liability whatsoever for any loss, whether it be direct, indirect or consequential, arising from this e-mail, nor for any consequence of its use or storage.

DISCLAIMER: This message and any attachments are confidential and intended solely for the addressee. If you have received this message in error, please notify the system manager/sender. Any unauthorized use, alteration or dissemination is prohibited. The Department of Water and Sanitation further accepts no liability whatsoever for any loss, whether it be direct, indirect or consequential, arising from this e-mail, nor for any consequence of its use or storage.



Virus-free. www.avast.com

DISCLAIMER: This message and any attachments are confidential and intended solely for the addressee. If you have received this message in error, please notify the system manager/sender. Any unauthorized use, alteration or dissemination is prohibited. The Department of Water and Sanitation further accepts no liability whatsoever for any loss, whether it be direct, indirect or consequential, arising from this e-mail, nor for any consequence of its use or storage.

Rozanne Els

From: Savannah Public Process <publicprocess@savannahsa.com>
Sent: 19 November 2018 2:16 PM
To: Mr. Moses Mahunonyane
Cc: shaun@savannahsa.com; rozanne@savannahsa.com
Subject: Hyperion 1, 2, 3 & 4 Solar PVs: Follow-up on comments on Scoping Report
Attachments: Hyperion Solar PVs-SRs AvailabilityNotificationLetter.pdf; Hyperion PVs SR Notification e-mail.pdf

Dear Mr Mahunoyane,

Mr Abe Abrahams directed me to you regarding the proposed four (4) Hyperion Solar PVs located near Kathu (Lower Vaal Catchment Area), Northern Cape Province.

The hard copies of the Scoping Reports were addressed to Mr Abrahams, as informed, and it is believed that your Registry receive these Reports and allocate it to the relevant Case Officer.

I would be appreciated if you can confirm whether you are the Case Officer for this proposed projects and who will be commenting on the Scoping Reports.

We are looking forward to hear from you.

Kind regards,

Nicolene Venter

Public Participation and Social Consultant | Savannah Environmental (Pty) Ltd
Tel: +27 (0)11 656 3237 | Fax: +27 (0)86 684 0547

SAWEA Award for Leading Environmental Consultant for Wind Projects in 2013 & 2015

HYPERION SOLAR PVs: Comment period on Scoping Reports

Search

Forward

Assigned to: Savannah Public Process	Date Sent: 26/11/2018 09:18
Teams: Global	Contacts: Henning Myburgh
From: Savannah Public Process <publicprocess@savannahsa.com>	
To: Mr. Henning Myburgh <henning@agrink.co.za>	
Cc: nicolene@savannahsa.com, shaun@savannahsa.com	
Bcc:	
Subject: HYPERION SOLAR PVs: Comment period on Scoping Reports	
<p>Body:</p> <p>Dear Henning,</p> <p>Thank you for your e-mail and telephone call this morning.</p> <p>Agri Northern Cape's request for extension on the Scoping Reports (SRs) (four proposed Solar Pv developments) has been discussed with the Project Manager and we can confirm that Agri Northern Cape has until Friday, 30 November 2018 to submit written comments.</p> <p>Should Agri Northern Cape not receive any other comments from your members on these four (4) SRs, we kindly request that it please be stated formally either in an e-mail or letter.</p> <p>Please do not hesitate to contact us should you require any additional information at this stage.</p> <p>Kind regards,</p> <p>Nicolene Venter</p> <p>Public Participation and Social Consultant Savannah Environmental (Pty) Ltd Tel: +27 (0)11 656 3237 Fax: +27 (0)86 684 0547</p> <p><i>SAWEA Award for Leading Environmental Consultant for Wind Projects in 2013 & 2015</i></p> <p><input type="checkbox"/> Show Plain Text</p>	
Attachments:	

 Activities

 (0 - 0 of 0)

Search

Attachments

Subject	Contact	Last Modified
No Data		

Accounts

Account Name	Town/City	Phone
No Data		

Contacts

Name	Organisation	Email	
Mr. Henning Myburgh	AgriSa Northern Cape	henning@agrink.co.za	edit

Email Stakeholders

Name	Organisation	Email	
Nicol Jansen	AgriSa Northern Cape	henning@agrink.co.za	edit
Henning Myburgh	AgriSa Northern Cape	henning@agrink.co.za	edit
Shaun Taylor	Savannah Environmental	shaun@savannahsa.com	edit
Nicolene Venter		nicolene@savannahsa.com	edit

Users

Name	User Name	Email	Phone
No Data			

Projects

Name	Assigned To	Start Date	End Date
No Data			

Savannah Environmental Public Process

From: John Geeringh <GeerinJH@eskom.co.za>
Sent: 06 November 2018 9:07 AM
To: Savannah Environmental Public Process
Subject: FW: Hyperion SEF 1-4
Attachments: Eskom requirements for work in or near Eskom servitudes SOLAR (3).doc; Renewable Energy Generation Plant Setbacks to Eskom Infrastructure - Signed.pdf

Just in case?
John



From: John Geeringh
Sent: 01 November 2018 09:36 AM
To: Nicolene Venter (nicolene@savannahsa.com)
Subject: Hyperion SEF 1-4

Please find attached Eskom requirements for works at or near Eskom infrastructure and servitudes. Please send me KMZ files of the affected properties and proposed layouts. Please send me the DEA reference numbers as soon as they become available.

Kind regards

John Geeringh (Pr Sci Nat)
Senior Consultant Environmental Management
Group Capital Division: Land Development and Management
Megawatt Park, D1Y42, Maxwell Drive, Sunninghill, Sandton.
P O Box 1091, Johannesburg, 2000.
Tel: 011 516 7233
Cell: 083 632 7663
Fax: 086 661 4064
E-mail: john.geeringh@eskom.co.za

NB: This Email and its contents are subject to the Eskom Holdings SOC Ltd EMAIL LEGAL NOTICE which can be viewed at http://www.eskom.co.za/Pages/Email_Legal_Spam_Disclaimer.aspx

Eskom requirements for work in or near Eskom servitudes.

1. Eskom's rights and services must be acknowledged and respected at all times.
2. Eskom shall at all times retain unobstructed access to and egress from its servitudes.
3. Eskom's consent does not relieve the developer from obtaining the necessary statutory, land owner or municipal approvals.
4. Any cost incurred by Eskom as a result of non-compliance to any relevant environmental legislation will be charged to the developer.
5. If Eskom has to incur any expenditure in order to comply with statutory clearances or other regulations as a result of the developer's activities or because of the presence of his equipment or installation within the servitude restriction area, the developer shall pay such costs to Eskom on demand.
6. The use of explosives of any type within 500 metres of Eskom's services shall only occur with Eskom's previous written permission. If such permission is granted the developer must give at least fourteen working days prior notice of the commencement of blasting. This allows time for arrangements to be made for supervision and/or precautionary instructions to be issued in terms of the blasting process. It is advisable to make application separately in this regard.
7. Changes in ground level may not infringe statutory ground to conductor clearances or statutory visibility clearances. After any changes in ground level, the surface shall be rehabilitated and stabilised so as to prevent erosion. The measures taken shall be to Eskom's satisfaction.
8. Eskom shall not be liable for the death of or injury to any person or for the loss of or damage to any property whether as a result of the encroachment or of the use of the servitude area by the developer, his/her agent, contractors, employees, successors in title, and assignees. The developer indemnifies Eskom against loss, claims or damages including claims pertaining to consequential damages by third parties and whether as a result of damage to or interruption of or interference with Eskom's services or apparatus or otherwise. Eskom will not be held responsible for damage to the developer's equipment.
9. No mechanical equipment, including mechanical excavators or high lifting machinery, shall be used in the vicinity of Eskom's apparatus and/or services, without prior written permission having been granted by Eskom. If such permission is granted the developer must give at least seven working days' notice prior to the commencement of work. This allows time for arrangements to be made for supervision and/or precautionary instructions to be issued by the relevant Eskom Manager

Note: Where and electrical outage is required, at least fourteen work days are required to arrange it.

10. Eskom's rights and duties in the servitude shall be accepted as having prior right at all times and shall not be obstructed or interfered with.
11. Under no circumstances shall rubble, earth or other material be dumped within the servitude restriction area. The developer shall maintain the area concerned to Eskom's satisfaction. The developer shall be liable to Eskom for the cost of any remedial action which has to be carried out by Eskom.
12. The clearances between Eskom's live electrical equipment and the proposed construction work shall be observed as stipulated by *Regulation 15 of the Electrical Machinery Regulations of the Occupational Health and Safety Act, 1993 (Act 85 of 1993)*.
13. Equipment shall be regarded electrically live and therefore dangerous at all times.
14. In spite of the restrictions stipulated by Regulation 15 of the Electrical Machinery Regulations of the Occupational Health and Safety Act, 1993 (Act 85 of 1993), as an additional safety precaution, Eskom will not approve the erection of houses, or structures occupied or frequented by human beings, under the power lines or within the servitude restriction area.
15. Eskom may stipulate any additional requirements to highlight any possible exposure to Customers or Public to coming into contact or be exposed to any dangers of Eskom plant.
16. It is required of the developer to familiarise himself with all safety hazards related to Electrical plant.
17. Any third party servitudes encroaching on Eskom servitudes shall be registered against Eskom's title deed at the developer's own cost. If such a servitude is brought into being, its existence should be endorsed on the Eskom servitude deed concerned, while the third party's servitude deed must also include the rights of the affected Eskom servitude.

John Geeringh (Pr Sci Nat)

Senior Consultant Environmental Management
Eskom GC: Land Development

	<p style="text-align: center;">SCOT</p>	<p style="text-align: center;">Technology</p>
---	--	--

Title: **Renewable Energy Generation Plant Setbacks to Eskom Infrastructure** Unique Identifier: **240-65559775**

Alternative Reference Number: **N/A**

Area of Applicability: **Power Line Engineering**

Documentation Type: **Guideline**

Revision: **0**

Total Pages: **8**

Next Review Date: **N/A**

Disclosure Classification: **CONTROLLED DISCLOSURE**

Compiled by



J W Chetty
Mechanical Engineer

Date: 20/02/2014

Approved by



V Naidoo
Chief Engineer (Lines)

Date: 24/02/2014

Authorised by

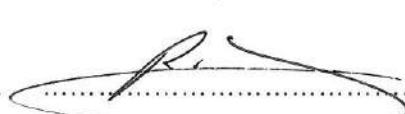

R A Vajeth
Acting Snr Manager (Lines)

Date: 27/2/2014

Supported by SCOT/SC

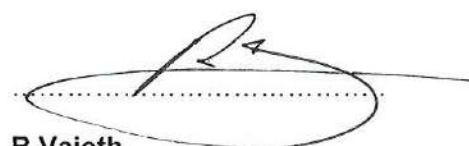

R Vajeth
SCOT/SC/ Chairperson

Date: 27/2/2014

PCM Reference: 240-65132732 **LINE ENGINEERING SERVICES**

SCOT Study Committee Number/Name : **OVERHEAD LINES**

CONTENTS

	Page
EXECUTIVE SUMMARY	3
1. INTRODUCTION	4
2. SUPPORTING CLAUSES	4
2.1 SCOPE	4
2.1.1 Purpose	4
2.1.2 Applicability	5
2.2 NORMATIVE/INFORMATIVE REFERENCES	5
2.2.1 Normative	5
2.2.2 Informative	5
2.3 DEFINITIONS	5
2.3.1 Disclosure Classification	6
2.4 ABBREVIATIONS	6
2.5 ROLES AND RESPONSIBILITIES	6
2.6 PROCESS FOR MONITORING	6
2.7 RELATED/SUPPORTING DOCUMENTS	6
3. DOCUMENT CONTENT	6
3.1 INTERNATIONAL SETBACK COMPARISON	6
3.2 ESKOM APPROACH FOR WIND FARMS	7
4. AUTHORISATION	8
5. REVISIONS	8
6. DEVELOPMENT TEAM	9

FIGURES

Figure 1: Horizontal Axis Wind Turbine	8
--	---

CONTROLLED DISCLOSURE

When downloaded from the EDMS, this document is uncontrolled and the responsibility rests with the user to ensure it is in line with the authorised version on the system.

EXECUTIVE SUMMARY

In recent decades, the use of wind turbines, concentrated solar plants and photovoltaic plants have been on the increase as it serves as an abundant source of energy. This document specifies setbacks for wind turbines and the reasons for these setbacks from infrastructure as well as setbacks for concentrated solar plants and photovoltaic plants. Setbacks for wind turbines employed in other countries were compared and a general setback to be used by Eskom was suggested for use with wind turbines and other renewable energy generation plants.

CONTROLLED DISCLOSURE

When downloaded from the EDMS, this document is uncontrolled and the responsibility rests with the user to ensure it is in line with the authorised version on the system.

1. INTRODUCTION

During the last few decades, a large amount of wind turbines have been installed in wind farms to accommodate for the large demand of energy and depleting fossil fuels. Wind is one of the most abundant sources of renewable energy. Wind turbines harness the energy of this renewable resource for integration in electricity networks. The extraction of wind energy is its primary function and thus the aerodynamics of the wind turbine is important. There are many different types of wind turbines which will all exhibit different wind flow characteristics. The most common wind turbine used commercially is the Horizontal Axis Wind Turbine. Wind flow characteristics of this turbine are important to analyse as it may have an effect on surrounding infrastructure.

Wind turbines also cause large turbulence downwind that may affect existing infrastructure. Debris or parts of the turbine blade, in the case of a failure, may be tossed behind the turbine and may lead to damage of infrastructure in the wake path.

This document outlines the minimum distances that need to be introduced between a wind turbine and Eskom infrastructure to ensure that debris and / or turbulence would not negatively impact on the infrastructure.

Safety distances of wind turbines from other structures as implemented by other countries were also considered and the reasons for their selection were noted.

Concentrated solar plants and photovoltaic plants setbacks away from substations were also to be considered to prevent restricting possible power line access routes to the substation.

2. SUPPORTING CLAUSES

2.1 SCOPE

This document provides guidance on the safe distance that a wind turbine should be located from any Eskom power line or substation. The document specifies setback distances for transmission lines (220 kV to 765 kV), distribution lines (6.6 kV to 132 kV) and all Eskom substations. Setbacks for concentrated solar plants and photovoltaic plants are also specified away from substations.

2.1.1 Purpose

Setbacks for wind turbines and power lines / substations are required for various reasons. These include possible catastrophic failure of the turbine blade that may release fragments and which may be thrown onto nearby power lines that may result in damage with associated unplanned outages. Turbulence behind the turbine may affect helicopter flight during routine Eskom live line maintenance and

CONTROLLED DISCLOSURE

When downloaded from the EDMS, this document is uncontrolled and the responsibility rests with the user to ensure it is in line with the authorised version on the system.

inspections that may lead to safety risk of the aircraft / personnel. Concentrated solar plants and photovoltaic plants setback away from substations were required to prevent substations from being boxed in by these renewable generation plants limiting line route access to the substations.

2.1.2 Applicability

This document is applicable to the siting of all new and existing wind turbines, concentrated solar plants and photovoltaic plants near power lines and substations.

2.2 NORMATIVE/INFORMATIVE REFERENCES

2.2.1 Normative

1. <http://www.envir.ee/orb.aw/class=file/action=preview/id=1170403/Hiiumaa+turbulence+impact+EMD.pdf>.
2. <http://www.energy.ca.gov/2005publications/CEC-500-2005-184/CEC-500-2005-184.PDF>
3. <http://www.adamscountywind.com/Revised%20Site/Windmills/Adams%20County%20Ordinance/Adams%20County%20Wind%20Ord.htm>
4. http://www.dsireusa.org/incentives/incentive.cfm?Incentive_Code=PA11R&RE=1&EE=1
5. <http://www.wind-watch.org/documents/european-setbacks-minimum-distance-between-wind-turbines-and-habitations/>
6. <http://www.publications.parliament.uk/pa/ld201011/ldbills/017/11017.1-i.html>
7. http://www.caw.ca/assets/pdf/Turbine_Safety_Report.pdf
8. Rogers J, Slegers N, Costello M. (2011) A method for defining wind turbine setback standards. Wind energy 10.1002/we.468

2.2.2 Informative

None

2.3 DEFINITIONS

Definition	Description
Setback	The minimum distance between a wind turbine and boundary line/dwelling/road/infrastructure/servitude etc.
Flicker	Effect caused when rotating wind turbine blades periodically cast shadows
Tip Height	The total height of the wind turbine ie. Hub height plus half rotor diameter (see Figure1)

CONTROLLED DISCLOSURE

When downloaded from the EDMS, this document is uncontrolled and the responsibility rests with the user to ensure it is in line with the authorised version on the system.

2.3.1 Disclosure Classification

Controlled disclosure: controlled disclosure to external parties (either enforced by law, or discretionary).

2.4 ABBREVIATIONS

Abbreviation	Description
None	

2.5 ROLES AND RESPONSIBILITIES

All personnel involved in the positioning wind turbines, concentrated solar plants and photovoltaic plants near power lines/substations must follow the setbacks outlined in this guideline.

2.6 PROCESS FOR MONITORING

Approval by Eskom in writing.

2.7 RELATED/SUPPORTING DOCUMENTS

None

3. DOCUMENT CONTENT

3.1 INTERNATIONAL SETBACK COMPARISON

Wind Turbine setbacks employed by various countries were considered. It was found that setbacks were determined for various reasons that include noise, flicker, turbine blade failure and wind effects. The distances (setbacks) varied based on these factors and were influenced by the type of infrastructure

Wind turbine setbacks varied for roads, power lines, dwellings, buildings and property and it was noted that the largest setbacks were employed for reasons of noise and flicker related issues [1-7]. Very few countries specified setbacks for power lines.

The literature survey [1-7], yielded information about studies and experiments were conducted to determine the distance that a broken fragment from a wind turbine might be thrown. Even though of low probability of hitting a power line [5.0×10^{-5}]^[8], the distances recorded were significant [750m]^[8]

Setbacks were thus introduced to prevent any damage to Eskom infrastructure.

CONTROLLED DISCLOSURE

When downloaded from the EDMS, this document is uncontrolled and the responsibility rests with the user to ensure it is in line with the authorised version on the system.

Wind turbines may also cause changes in wind patterns with turbulent effects behind the hub. These factors dictate the wind turbine setbacks specified in this document.

Concentrated solar plants and photovoltaic plants also can limit access into the substation for power lines of all voltages. A setback distance must therefore be employed to prevent the substation from being boxed in by these generation plants. These setback distances are specified in this document.

3.2 ESKOM REQUIRED SETBACKS

- Eskom requires a setback distance of 3 times the tip height of the wind turbine from the edge of the closest Eskom servitude (including vacant servitudes) for transmission lines.
- Eskom requires a setback distance of 1 times the tip height of the wind turbine from the edge of the closest Eskom servitude (including vacant servitudes) for distribution Lines.
- Eskom must be informed of any proposed wind turbine, concentrated solar plants and photovoltaic activity within a 5 km radius of a substation. No wind turbine structure shall be built within a 2 km radius of the closest point of the substation. Where concentrated solar plants and photovoltaic structures fall within a 2 km radius of the closest point of a substation, Eskom should be informed in writing during the planning phase of the construction of such plant or structure.
- Applicants must show that Eskom radio telecommunication systems (mainly microwave systems) will not be affected in any way by wind turbines.

CONTROLLED DISCLOSURE

When downloaded from the EDMS, this document is uncontrolled and the responsibility rests with the user to ensure it is in line with the authorised version on the system.

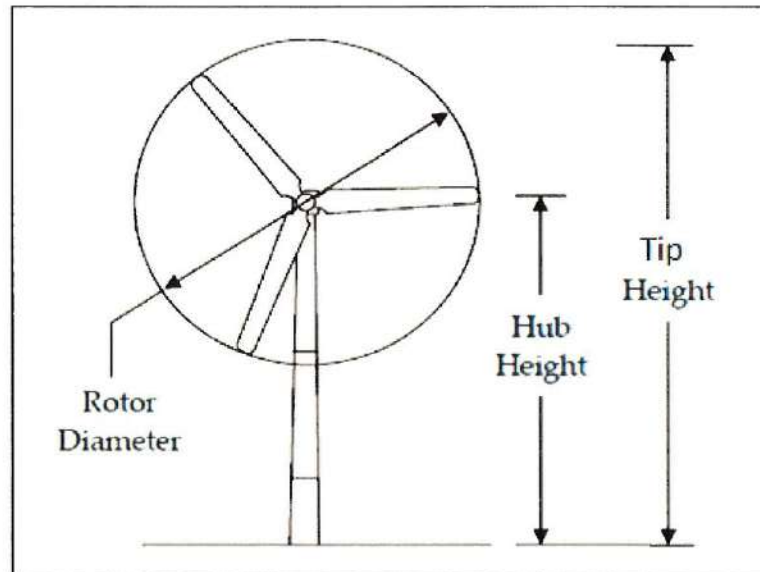

Figure 1: Horizontal Axis Wind Turbine ^[2]

4. AUTHORISATION

This document has been seen and accepted by:

Name & Surname	Designation
V Naidoo	Chief Engineer
Dr P H Pretorius	Electrical Specialist
J Geeringh	Snr Consultant Environ Mngt
B Haridass	Snr Consultant Engineer
R A Vajeth	Acting Snr Manager (Lines)

5. REVISIONS

Date	Rev.	Compiler	Remarks
November 2013	0	J W Chetty	First Publication - No renewable energy generation plant setback specification in existence

CONTROLLED DISCLOSURE

When downloaded from the EDMS, this document is uncontrolled and the responsibility rests with the user to ensure it is in line with the authorised version on the system.

6. DEVELOPMENT TEAM

The following people were involved in the development of this document:

Jonathan W Chetty (Mechanical Engineer)

Vivendhra Naidoo (Chief Engineer)

Dr Pieter H Pretorius (Electrical Specialist)

John Geeringh (Snr Consultant Environ Mngt)

Bharat Haridass (Snr Consultant Engineer)

Riaz A Vajeth (Acting Snr Manager (Lines))

CONTROLLED DISCLOSURE

When downloaded from the EDMS, this document is uncontrolled and the responsibility rests with the user to ensure it is in line with the authorised version on the system.

ATTEMPTS TO ATTAIN COMMENTS

Savannah Environmental Public Process

From: Savannah Environmental Public Process <publicprocess@savannahsa.com>
Sent: 21 November 2018 7:38 AM
To: 'henning@agrink.co.za'
Subject: Request for Comment - Hyperion Solar Development
Attachments: Hyperion Solar PVs-SRs AvailabilityNotificationLetter.pdf

Importance: High

Dear Nicol,

With reference to the attached notification letter in regards to the Hyperion Solar Development projects, we noted that we have not yet received written comment on the Scoping Report for public review from AgriSa.

This e-mail serves as a reminder that the comment period for the above mentioned project ends on **Monday, 26 November 2018.**

It would be appreciated if you can submit written comment before or on **Monday, 26 November 2018** by close of business.

Should you not have any comments, please inform us accordingly.

Kind regards,

Savannah Environmental Public Process

From: Savannah Environmental Public Process <publicprocess@savannahsa.com>
Sent: 21 November 2018 7:39 AM
To: 'Simphiwe Masilela'
Subject: Request for Comment - Hyperion Solar Development
Attachments: Hyperion Solar PVs-SRs AvailabilityNotificationLetter.pdf

Importance: High

Dear Simphiwe,

With reference to the attached notification letter in regards to the Hyperion Solar Development projects, we noted that we have not yet received written comment on the Scoping Report for public review from ANTS.

This e-mail serves as a reminder that the comment period for the above mentioned project ends on **Monday, 26 November 2018.**

It would be appreciated if you can submit written comment before or on **Monday, 26 November 2018** by close of business.

Should you not have any comments, please inform us accordingly.

Kind regards,

Savannah Environmental Public Process

From: Savannah Environmental Public Process <publicprocess@savannahsa.com>
Sent: 21 November 2018 7:04 AM
To: 'jacolinema@daff.gov.za'
Subject: Request for Comment - Hyperion Solar Development
Attachments: Hyperion Solar PVs-SRs AvailabilityNotificationLetter.pdf

Importance: High

Dear Jacoline,

With reference to the attached notification letter in regards to the Hyperion Solar Development projects, we noted that we have not yet received written comment on the Scoping Report for public review from the Department of Agriculture, Forestry and Fisheries.

This e-mail serves as a reminder that the comment period for the above mentioned project ends on **Monday, 26 November 2018.**

It would be appreciated if you can submit written comment before or on **Monday, 26 November 2018** by close of business.

Should you not have any comments, please inform us accordingly.

Kind regards,

Savannah Environmental Public Process

From: Savannah Environmental Public Process <publicprocess@savannahsa.com>
Sent: 21 November 2018 7:01 AM
To: 'thokob@daff.gov.za'; 'mashuduma@daff.gov.za'
Subject: Request for Comment - Hyperion Solar Development
Attachments: Hyperion Solar PVs-SRs AvailabilityNotificationLetter.pdf

Importance: High

Dear Thoko and Mashudu,

With reference to the attached notification letter in regards to the Hyperion Solar Development projects, we noted that we have not yet received written comment on the Scoping Report for public review from the Department of Agriculture, Forestry and Fisheries.

This e-mail serves as a reminder that the comment period for the above mentioned project ends on **Monday, 26 November 2018.**

It would be appreciated if you can submit written comment before or on **Monday, 26 November 2018** by close of business.

Should you not have any comments, please inform us accordingly.

Kind regards,

Savannah Environmental Public Process

From: Savannah Environmental Public Process <publicprocess@savannahsa.com>
Sent: 21 November 2018 7:22 AM
To: 'Stanley Tshitwamulomoni'
Subject: Request for Comment - Hyperion Solar Development
Attachments: Hyperion Solar PVs-SRs AvailabilityNotificationLetter.pdf

Importance: High

Dear Stanley,

With reference to the attached notification letter in regards to the Hyperion Solar Development projects, we noted that we have not yet received written comment on the Scoping Report for public review from the Department of Environmental Affairs: Biodiversity.

This was the last project submitted to DEA: Biodiversity for attention to Wilma Lutch. With reference to my email confirming that you are the relevant person, we will make sure to address all future projects to you.

This e-mail serves as a reminder that the comment period for the above mentioned project ends on **Monday, 26 November 2018.**

It would be appreciated if you can submit written comment before or on **Monday, 26 November 2018** by close of business.

Should you not have any comments, please inform us accordingly.

Kind regards,

Rozanne Els

From: Shaun Taylor <shaun@savannahsa.com>
Sent: 04 December 2018 3:29 PM
To: JMpelane@environment.gov.za
Cc: 'Nicolene Venter'; 'Jo-Anne Thomas'; thalita@savannahsa.com; 'Rozanne Els'
Subject: RE: DEA Comments Hyperion Solar Development 4 Ref: 14/12/16/3/3/2/1112

Importance: High

Dear Jay-Jay

This email serves to follow up on the request below for comments on this project (Hyperion Solar Development 4 Ref: 14/12/16/3/3/2/1112).

We wish to submit the FSR, but require your comments before we can finalise.

Regards

Shaun Taylor

Environmental and Permitting Lead Consultant | Savannah Environmental (Pty) Ltd
Tel: +27 (0)11 656 3237 | Cell: +27(0)72 779 4899 | Fax: +27 (0)86 684 0547

[SAWEA Award for Leading Environmental Consultant for Wind Projects in 2013 & 2015](#)

From: Shaun Taylor <shaun@savannahsa.com>
Sent: Thursday, 29 November 2018 13:46
To: 'JMpelane@environment.gov.za' <JMpelane@environment.gov.za>
Cc: 'Nicolene Venter' <nicolene@savannahsa.com>; 'Jo-Anne Thomas' <joanne@savannahsa.com>; 'thalita@savannahsa.com' <thalita@savannahsa.com>; 'Rozanne Els' <rozanne@savannahsa.com>
Subject: DEA Comments Hyperion Solar Development 4 Ref: 14/12/16/3/3/2/1112
Importance: High

Dear Jay-Jay

Please note that we are awaiting comments from the Department for project reference: 14/12/16/3/3/2/1112 (Hyperion Solar Development 4) from the Department. Importantly, note that the comment period has ended as of 26 November 2018.

We have checked with EIA admin who have referred us to you as the case officer.

Kindly advise when these can be received.

We look forward to your soonest response.

Regards

Rozanne Els

From: Shaun Taylor <shaun@savannahsa.com>
Sent: 06 December 2018 11:50 AM
To: JMpelane@environment.gov.za
Cc: 'Nicolene Venter'; 'Jo-Anne Thomas'; thalita@savannahsa.com; 'Rozanne Els'
Subject: RE: DEA Comments Hyperion Solar Development 4 Ref: 14/12/16/3/3/2/1112

Hi Jay-jay

Thank you for taking my call today.

As per our discussion, given that the comments will only follow through in the EIA phase, should the plan of study be approved, we will finalise the Scoping Report for submission to DEA for decision making.

Regards

Shaun Taylor

Environmental and Permitting Lead Consultant | Savannah Environmental (Pty) Ltd
Tel: +27 (0)11 656 3237 | Cell: +27(0)72 779 4899 | Fax: +27 (0)86 684 0547

[SAWEA Award for Leading Environmental Consultant for Wind Projects in 2013 & 2015](#)

From: Shaun Taylor <shaun@savannahsa.com>
Sent: Tuesday, 04 December 2018 15:29
To: 'JMpelane@environment.gov.za' <JMpelane@environment.gov.za>
Cc: 'Nicolene Venter' <nicolene@savannahsa.com>; 'Jo-Anne Thomas' <joanne@savannahsa.com>; 'thalita@savannahsa.com' <thalita@savannahsa.com>; 'Rozanne Els' <rozanne@savannahsa.com>
Subject: RE: DEA Comments Hyperion Solar Development 4 Ref: 14/12/16/3/3/2/1112
Importance: High

Dear Jay-Jay

This email serves to follow up on the request below for comments on this project (Hyperion Solar Development 4 Ref: 14/12/16/3/3/2/1112).

We wish to submit the FSR, but require your comments before we can finalise.

Regards

Shaun Taylor

Environmental and Permitting Lead Consultant | Savannah Environmental (Pty) Ltd
Tel: +27 (0)11 656 3237 | Cell: +27(0)72 779 4899 | Fax: +27 (0)86 684 0547

[SAWEA Award for Leading Environmental Consultant for Wind Projects in 2013 & 2015](#)

From: Shaun Taylor <shaun@savannahsa.com>
Sent: Thursday, 29 November 2018 13:46
To: 'JMpelane@environment.gov.za' <JMpelane@environment.gov.za>
Cc: 'Nicolene Venter' <nicolene@savannahsa.com>; 'Jo-Anne Thomas' <joanne@savannahsa.com>; 'thalita@savannahsa.com' <thalita@savannahsa.com>; 'Rozanne Els' <rozanne@savannahsa.com>
Subject: DEA Comments Hyperion Solar Development 4 Ref: 14/12/16/3/3/2/1112
Importance: High

Dear Jay-Jay

Please note that we are awaiting comments from the Department for project reference: 14/12/16/3/3/2/1112 (Hyperion Solar Development 4) from the Department. Importantly, note that the comment period has ended as of 26 November 2018.

We have checked with EIA admin who have referred us to you as the case officer.

Kindly advise when these can be received.

We look forward to your soonest response.

Regards

Savannah Environmental Public Process

From: Savannah Environmental Public Process <publicprocess@savannahsa.com>
Sent: 21 November 2018 7:17 AM
To: 'sdelafontaine@gmail.com'
Subject: Request for Comment - Hyperion Solar Development
Attachments: Hyperion Solar PVs-SRs AvailabilityNotificationLetter.pdf

Importance: High

Dear Samantha,

With reference to the attached notification letter in regards to the Hyperion Solar Development projects, we noted that we have not yet received written comment on the Scoping Report for public review from the Department of Environmental and Nature Conservation: Northern Cape

This e-mail serves as a reminder that the comment period for the above mentioned project ends on **Monday, 26 November 2018.**

It would be appreciated if you can submit written comment before or on **Monday, 26 November 2018** by close of business.

Should you not have any comments, please inform us accordingly.

Kind regards,

Savannah Environmental Public Process

From: Savannah Environmental Public Process <publicprocess@savannahsa.com>
Sent: 21 November 2018 7:29 AM
To: 'BFisher@ncpg.gov.za'
Subject: Request for Comment - Hyperion Solar Development
Attachments: Hyperion Solar PVs-SRs AvailabilityNotificationLetter.pdf

Importance: High

Dear Bryan,

With reference to the attached notification letter in regards to the Hyperion Solar Development projects, we noted that we have not yet received written comment on the Scoping Report for public review from the Northern Cape Department of Environment and Nature Conservation.

This e-mail serves as a reminder that the comment period for the above mentioned project ends on **Monday, 26 November 2018.**

It would be appreciated if you can submit written comment before or on **Monday, 26 November 2018** by close of business.

Should you not have any comments, please inform us accordingly.

Kind regards,

Savannah Environmental Public Process

From: Savannah Environmental Public Process <publicprocess@savannahsa.com>
Sent: 21 November 2018 7:06 AM
To: 'Pheladi.Masipa@energy.gov.za'
Subject: Request for Comment - Hyperion Solar Development
Attachments: Hyperion Solar PVs-SRs AvailabilityNotificationLetter.pdf

Importance: High

Dear Pheladi,

With reference to the attached notification letter in regards to the Hyperion Solar Development projects, we noted that we have not yet received written comment on the Scoping Report for public review from the Department of Energy.

This e-mail serves as a reminder that the comment period for the above mentioned project ends on **Monday, 26 November 2018.**

It would be appreciated if you can submit written comment before or on **Monday, 26 November 2018** by close of business.

Should you not have any comments, please inform us accordingly.

Kind regards,

Savannah Environmental Public Process

From: Savannah Environmental Public Process <publicprocess@savannahsa.com>
Sent: 21 November 2018 7:26 AM
To: 'roelofse.j@vodamail.co.za'
Subject: Request for Comment - Hyperion Solar Development
Attachments: Hyperion Solar PVs-SRs AvailabilityNotificationLetter.pdf

Importance: High

Dear Jaco,

With reference to the attached notification letter in regards to the Hyperion Solar Development projects, we noted that we have not yet received written comment on the Scoping Report for public review from the Department of Roads and Public Works.

This e-mail serves as a reminder that the comment period for the above mentioned project ends on **Monday, 26 November 2018.**

It would be appreciated if you can submit written comment before or on **Monday, 26 November 2018** by close of business.

Should you not have any comments, please inform us accordingly.

Kind regards,

Savannah Environmental Public Process

From: Savannah Environmental Public Process <publicprocess@savannahsa.com>
Sent: 21 November 2018 7:28 AM
To: 'franksl@dwa.gov.za'
Cc: 'shibambus@dwa.gov.za'
Subject: Request for Comment - Hyperion Solar Development
Attachments: Hyperion Solar PVs-SRs AvailabilityNotificationLetter.pdf

Importance: High

Dear Abe,

With reference to the attached notification letter in regards to the Hyperion Solar Development projects, we noted that we have not yet received written comment on the Scoping Report for public review from the Department of Water and Sanitation.

This e-mail serves as a reminder that the comment period for the above mentioned project ends on **Monday, 26 November 2018.**

It would be appreciated if you can submit written comment before or on **Monday, 26 November 2018** by close of business.

Should you not have any comments, please inform us accordingly.

Kind regards,

Rozanne Els

From: Nicolene Venter <nicolene@savannahsa.com>
Sent: 26 November 2018 4:39 PM
To: 'Magonono Fhatuwani Aron (KBY)'; 'Moalosi Kelebogile(KBY)'
Cc: 'Shaun Taylor'; 'Rozanne Els'
Subject: RE: Hyperion Solar PVs 1, 2, 3 & 4: DWS Comments (corrections to follow)

Dear Aron,

Feedback appreciated.

Nicolene Venter

Public Participation & Social Consultant | Savannah Environmental (Pty) Ltd
Tel: +27 (0)11 656 3237 | Fax: +27 (0)86 684 0547

[SAWEA Award for Leading Environmental Consultant for Wind Projects in 2013 & 2015](#)

From: Magonono Fhatuwani Aron (KBY) <MagononoF@dws.gov.za>
Sent: Monday, November 26, 2018 4:24 PM
To: Nicolene Venter <nicolene@savannahsa.com>; Moalosi Kelebogile(KBY) <MoalosiK2@dws.gov.za>
Cc: 'Shaun Taylor' <shaun@savannahsa.com>; 'Rozanne Els' <rozanne@savannahsa.com>
Subject: RE: Hyperion Solar PVs 1, 2, 3 & 4: DWS Comments (corrections to follow)

Some of your applications are with other case officers.

From: Nicolene Venter [mailto:nicolene@savannahsa.com]
Sent: 26 November 2018 04:16 PM
To: Magonono Fhatuwani Aron (KBY); Moalosi Kelebogile(KBY)
Cc: 'Shaun Taylor'; 'Rozanne Els'
Subject: Hyperion Solar PVs 1, 2, 3 & 4: DWS Comments (corrections to follow)

Good Day Aron,

Thank you for the updated information below.

We await the updated signed letters for the four (4) Hyperion Solar PV projects.

Kind regards,

Nicolene Venter

Public Participation & Social Consultant | Savannah Environmental (Pty) Ltd
Tel: +27 (0)11 656 3237 | Fax: +27 (0)86 684 0547

[SAWEA Award for Leading Environmental Consultant for Wind Projects in 2013 & 2015](#)

From: Magonono Fhatuwani Aron (KBY) [mailto:MagononoF@dws.gov.za]
Sent: 26 November 2018 12:17 PM
To: publicprocess@savannahsa.com
Subject: RE: Message from KM_C364e

Good morning Nicolene Venter

Just ignore the letters that were signed on the **21/11/2018**, there was mistakes with the footer. Our admin office did not see that those letters were amended. Therefore the correct letters should have the date of the 26/11/2018.

Hope you will find this in order,

Best regards
Aron

From: Moalosi Kelebogile(KBY)
Sent: 26 November 2018 12:05 PM
To: publicprocess@savannahsa.com
Cc: Magonono Fhatuwani Aron (KBY)
Subject: FW: Message from KM_C364e

Ms. Nicolene Venter,

The attached is for your attention, please note the original will be posted to you.

Warm Regards,

Kelebogile Moalosi
Lower Vaal Catchment (Admin Support)
28 Central Road
Beaconsfield
Kimberley
8301

Tel: 053 836 7606
Email: MoalosiK2@dwa.gov.za

DISCLAIMER: This message and any attachments are confidential and intended solely for the addressee. If you have received this message in error, please notify the system manager/sender. Any unauthorized use, alteration or dissemination is prohibited. The Department of Water and Sanitation further accepts no liability whatsoever for any loss, whether it be direct, indirect or consequential, arising from this e-mail, nor for any consequence of its use or storage.



Virus-free. www.avast.com

DISCLAIMER: This message and any attachments are confidential and intended solely for the addressee. If you have received this message in error, please notify the system manager/sender. Any unauthorized use, alteration or dissemination is prohibited. The Department of Water and Sanitation further accepts no liability whatsoever for any loss, whether it be direct, indirect or consequential, arising from this e-mail, nor for any consequence of its use or storage.

Savannah Environmental Public Process

From: Savannah Environmental Public Process <publicprocess@savannahsa.com>
Sent: 21 November 2018 7:24 AM
To: 'Mmboneni.Mutheiwana@dmr.gov.za'
Subject: Request for Comment - Hyperion Solar Development
Attachments: Hyperion Solar PVs-SRs AvailabilityNotificationLetter.pdf

Importance: High

Dear Kevin,

With reference to the attached notification letter in regards to the Hyperion Solar Development projects, we noted that we have not yet received written comment on the Scoping Report for public review from the Department of Mineral Resources.

This e-mail serves as a reminder that the comment period for the above mentioned project ends on **Monday, 26 November 2018.**

It would be appreciated if you can submit written comment before or on **Monday, 26 November 2018** by close of business.

Should you not have any comments, please inform us accordingly.

Kind regards,

Savannah Environmental Public Process

From: Savannah Environmental Public Process <publicprocess@savannahsa.com>
Sent: 21 November 2018 7:32 AM
To: 'Makgalemele@drdlr.gov.za'
Subject: Request for Comment - Hyperion Solar Development
Attachments: Hyperion Solar PVs-SRs AvailabilityNotificationLetter.pdf

Importance: High

Dear Nozizwe,

With reference to the attached notification letter in regards to the Hyperion Solar Development projects, we noted that we have not yet received written comment on the Scoping Report for public review from the Department of Rural Development and Land Reform.

We have noted that the courier package with the CD for your attention was sent back to us. We could not reach you for comment on the matter.

This e-mail serves as a reminder that the comment period for the above mentioned project ends on **Monday, 26 November 2018**.

It would be appreciated if you can submit written comment before or on **Monday, 26 November 2018** by close of business.

Should you not have any comments, please inform us accordingly.

Kind regards,

Savannah Environmental Public Process

From: Savannah Environmental Public Process <publicprocess@savannahsa.com>
Sent: 21 November 2018 7:35 AM
To: 'clementi@gamagara.gov.za'
Subject: Request for Comment - Hyperion Solar Development
Attachments: Hyperion Solar PVs-SRs AvailabilityNotificationLetter.pdf

Importance: High

Dear Thusoeng ,

With reference to the attached notification letter in regards to the Hyperion Solar Development projects, we noted that we have not yet received written comment on the Scoping Report for public review from the Gamagara Local Municipality.

This e-mail serves as a reminder that the comment period for the above mentioned project ends on **Monday, 26 November 2018.**

It would be appreciated if you can submit written comment before or on **Monday, 26 November 2018** by close of business.

Should you not have any comments, please inform us accordingly.

Kind regards,

Savannah Environmental Public Process

From: Savannah Environmental Public Process <publicprocess@savannahsa.com>
Sent: 21 November 2018 7:34 AM
To: 'dmolaole@taologaetsewe.gov.za'
Subject: Request for Comment - Hyperion Solar Development
Attachments: Hyperion Solar PVs-SRs AvailabilityNotificationLetter.pdf

Importance: High

Dear Disang,

With reference to the attached notification letter in regards to the Hyperion Solar Development projects, we noted that we have not yet received written comment on the Scoping Report for public review from the John Taolo Gaetsewe District Municipality.

This e-mail serves as a reminder that the comment period for the above mentioned project ends on **Monday, 26 November 2018.**

It would be appreciated if you can submit written comment before or on **Monday, 26 November 2018** by close of business.

Should you not have any comments, please inform us accordingly.

Kind regards,

Savannah Environmental Public Process

From: Savannah Environmental Public Process <publicprocess@savannahsa.com>
Sent: 21 November 2018 7:37 AM
To: 'ratha.timothy@gmail.com'
Subject: Request for Comment - Hyperion Solar Development
Attachments: Hyperion Solar PVs-SRs AvailabilityNotificationLetter.pdf

Importance: High

Dear Timothy,

With reference to the attached notification letter in regards to the Hyperion Solar Development projects, we noted that we have not yet received written comment on the Scoping Report for public review from NERSA.

This e-mail serves as a reminder that the comment period for the above mentioned project ends on **Monday, 26 November 2018.**

It would be appreciated if you can submit written comment before or on **Monday, 26 November 2018** by close of business.

Should you not have any comments, please inform us accordingly.

Kind regards,

Savannah Environmental Public Process

From: Savannah Environmental Public Process <publicprocess@savannahsa.com>
Sent: 21 November 2018 7:40 AM
To: 'Abrahamsn@nra.co.za'
Subject: Request for Comment - Hyperion Solar Development
Attachments: Hyperion Solar PVs-SRs AvailabilityNotificationLetter.pdf

Importance: High

Dear Nicole,

With reference to the attached notification letter in regards to the Hyperion Solar Development projects, we noted that we have not yet received written comment on the Scoping Report for public review from SANRAL.

This e-mail serves as a reminder that the comment period for the above mentioned project ends on **Monday, 26 November 2018.**

It would be appreciated if you can submit written comment before or on **Monday, 26 November 2018** by close of business.

Should you not have any comments, please inform us accordingly.

Kind regards,

Savannah Environmental Public Process

From: Savannah Environmental Public Process <publicprocess@savannahsa.com>
Sent: 21 November 2018 7:41 AM
To: 'atiplady@ska.ac.za'
Subject: Request for Comment - Hyperion Solar Development
Attachments: Hyperion Solar PVs-SRs AvailabilityNotificationLetter.pdf

Importance: High

Dear Adrian,

With reference to the attached notification letter in regards to the Hyperion Solar Development projects, we noted that we have not yet received written comment on the Scoping Report for public review from SKA.

This e-mail serves as a reminder that the comment period for the above mentioned project ends on **Monday, 26 November 2018.**

It would be appreciated if you can submit written comment before or on **Monday, 26 November 2018** by close of business.

Should you not have any comments, please inform us accordingly.

Kind regards,

Savannah Environmental Public Process

From: Savannah Environmental Public Process <publicprocess@savannahsa.com>
Sent: 21 November 2018 7:07 AM
To: 'kebasenosi@yahoo.com'
Subject: Request for Comment - Hyperion Solar Development
Attachments: Hyperion Solar PVs-SRs AvailabilityNotificationLetter.pdf

Importance: High

Dear Kebasenosi,

With reference to the attached notification letter in regards to the Hyperion Solar Development projects, we noted that we have not yet received written comment on the Scoping Report for public review from the South African Defence Force.

This e-mail serves as a reminder that the comment period for the above mentioned project ends on **Monday, 26 November 2018.**

It would be appreciated if you can submit written comment before or on **Monday, 26 November 2018** by close of business.

Should you not have any comments, please inform us accordingly.

Kind regards,

DEPARTMENT OF WATER AND SANITATION

04 April 2019

Ms Janine Nale
Institutional Establishment: Water Quality Management
Department of Water & Sanitation
185 Francis Baart Street
PRETORIA 0001

By Courier Services

Dear Ms Nale,

**HYPERION SOLAR DEVELOPMENTS 1 AND 2 AND ASSOCIATED INFRASTRUCTURE,
KATHU, NORTHERN CAPE PROVINCE
(DEA Ref.No.: Hyperion PV1 - 14/12/16/3/3/2/1109 & DEA Ref.No.: Hyperion PV2 - 14/12/16/3/3/2/1110)**

NOTIFICATION OF AVAILABILITY OF ENVIRONMENTAL IMPACT ASSESSMENT REPORTS FOR REVIEW

The development of two (2) separate photovoltaic (PV) solar energy facilities (SEFs) as well as associated infrastructure are being proposed on the Remaining Extent of the Farm Lyndoch 432 situated approximately 16km north of Kathu in the Northern Cape Province. The proposed SEFs fall within the jurisdiction of the Gamagara Local Municipality and within the greater John Taolo Gaetsewe District Municipality. These facilities are called:

- » Hyperion Solar Development 1; and
- » Hyperion Solar Development 2;

This letter serves to inform you that the Environmental Impact Assessment Reports (EIARs) are available for your Department's review and written comments, and a CD containing the EIARs is included in this envelope.

Please note that the EIARs review period is from **Friday, 5 April 2019** to **Friday, 10 May 2019** and we are looking forward receiving your Department's written comment on the EIARs before or on the closing date of the review period.

Kind regards



NICOLENE VENTER

Public Participation and Social Consultant

E-mail: publicprocess@savannahsa.com



0861 223 224
www.dawnwing.co.za

WAYBILL



FROM: Address SAVANNAH ENVIRONMENT 5 WOODLANDS DRIVE OFFICE PARK CNR WOODLANDS DR & WESTERN SERVICE ROAD WOODMEAD EXT LISA TO: Dep of water & sanitation 185 Francis Baart Street		PARCEL DETAILS		HAZARDOUS		Service (mark only one)	
Contents: <i>cb</i>		No. of Parcels: 1		Yes <input type="checkbox"/> No <input type="checkbox"/>		Economy Cargo <input checked="" type="checkbox"/>	
Dimensions (cm): 40 x 30 x 1		Mess(kg)-Ts & C's Apply: <i>0.5</i>		International Documents <input type="checkbox"/>		Domestic Road Freight <input type="checkbox"/>	
Postal Code must be filled in: 2191		Postal Code must be filled in: 0001		International Documents (non)		International Road Freight <input type="checkbox"/>	
Senders Name: LISA		City/Country: Pretoria		Special Instructions		SPECIAL INSTRUCTIONS	
City/Country: Pretoria		Receiver's Name: Janine Vale		Dawn Wing reserves the right to mark the service "Overnight Express" should no service level be selected		SUNDAY / PUBLIC HOLIDAY <input type="checkbox"/>	
By signing this waybill the sender is concluding a contract with Dawn Wing and authorizing to enter into this contract and to bind the entity, which hereby represents and warrants that the information provided hereon is true and correct.		Date: 07/09/2016		CASH R AMOUNT		Tick to select limiter liability option (for a maximum amount of R50 000) for non-excluded articles: <input type="checkbox"/>	
Senders Name: Georgina		Date: 07/09/2016		PAID YES NO		Value of Article: ZAR	
Signature: <i>[Signature]</i>		City/Country: Pretoria		Special Instructions		Account to be Debited: JB592	
DAWN WING		DAWN WING		Terms strictly 30 days from date of statement		Sender's Ref. / Bag No.	
A Division of DPD Laser Express Logistics (Pty) Ltd		A Division of DPD Laser Express Logistics (Pty) Ltd		Dawn Wing strictly 30 days from date of statement		RECEIVED IN GOOD ORDER AND IN CONDITION	
Reg. No. 2006/033332/07 VAT No. 46923280		Reg. No. 2006/033332/07 VAT No. 46923280		Dawn Wing strictly 30 days from date of statement		Receivers Signature: <i>[Signature]</i>	
FSP NO 32009		FSP NO 32009		Dawn Wing strictly 30 days from date of statement		Print Name: <i>[Name]</i>	
				Dawn Wing strictly 30 days from date of statement		Date: 07/09/2016 Time: 09:10	

Sender to complete yellow areas only

PROOF OF DELIVERY
*All weight and dimensions subject to verification through electronic weight and dimension machine (SABS calibrated)

04 April 2019

Mr Abe Abrahams
Director
Department of Water & Sanitation
28 Central Road
Beaconsfield
KIMBERLEY

By Courier Services

Dear Mr Abrahams,

**HYPERION SOLAR DEVELOPMENTS 1 AND 2 AND ASSOCIATED INFRASTRUCTURE,
KATHU, NORTHERN CAPE PROVINCE
(DEA Ref.No.: Hyperion PV1 - 14/12/16/3/3/2/1109 & DEA Ref.No.: Hyperion PV2 - 14/12/16/3/3/2/1110)**

NOTIFICATION OF AVAILABILITY OF ENVIRONMENTAL IMPACT ASSESSMENT REPORTS FOR REVIEW

The development of two (2) separate photovoltaic (PV) solar energy facilities (SEFs) as well as associated infrastructure are being proposed on the Remaining Extent of the Farm Lyndoch 432 situated approximately 16km north of Kathu in the Northern Cape Province. The proposed SEFs fall within the jurisdiction of the Gamagara Local Municipality and within the greater John Taolo Gaetsewe District Municipality. These facilities are called:

- » Hyperion Solar Development 1; and
- » Hyperion Solar Development 2;

This letter serves to inform you that the Environmental Impact Assessment Reports (EIARs) are available for your Department's review and written comments, and a hard copy of the EIARs and a CD containing the EIARs is included in this envelope.

Please note that the EIARs review period is from **Friday, 5 April 2019** to **Friday, 10 May 2019** and we are looking forward receiving your Department's written comment on the EIARs before or on the closing date of the review period.

Kind regards



NICOLENE VENTER

Public Participation and Social Consultant
E-mail: publicprocess@savannahsa.com

Reminder: Hyperion EIA 1 & 2 - Environmental Impact Assessment Reports review ending soon soon

Search

Forward

Assigned to: Savannah Public Process	Date Sent: 06/05/2019 08:23
Teams: Global	Project: Hyperion Solar Kathu, Northern Cape
From: Savannah Public Process <publicprocess@savannahsa.com>	
To: nicolene@savannahsa.com, mabel@savannahsa.com	
Cc:	
Bcc: Abe Abrahams <franksl@dwa.gov.za>, Nicole Abrahams <abrahamsn@nra.co.za>, Amanda Bester <wayleacr@telkom.co.za>, Lebo Bitsangk <bitsangk@gamagara.gov.za>, Jerome Bob <jerome@gamagara.co.za>, Jim Bredenkamp <jim@jimpos.co.za>, Schalk Burger <pnpvoerkrale@gmail.com>, Linda Burger <burgerlb@gmail.com>, Sarel Jacobus (sakkie) Burger <burgersarel7@gmail.com>, Thoko Buthelezi <thokob@daff.gov.za>, Thabo Chaka <thabo.chaka@gmail.com>, Shaun Cloete <cloetes@dws.gov.za>, Get Coetzee <gcoetzee@volksblad.com>, Ina Coetzer <jancoetzer@egate.co.za>, Karen de Bruyn <eia@g7energies.com>, Samantha De la Fontaine <sdelafontaine@gmail.com>, Janine De Wee <deweelj@gamagara.gov.za>, Bryan Fisher <bfisher@ncpg.gov.za>, Simon Gear <advocacy@birdlife.org.za>, John Geeringh <john.geeringh@eskom.co.za>, Henrietta Hager <hager.henri@gmail.com>, Sharief Harris <s.harris@buildingenergy.it>, Natasha Higgitt <nhiggitt@sahra.org.za>, Thokozani Hlophe <thokozani.hlophe@angloamerican.com>, Constant Hoogstad <constanth@ewt.org.za>, Thusoeng Itumeleng <clementi@gamagara.gov.za>, Nicol Jansen <henning@agrink.co.za>, Charlotte Joseph <josephc@gamagara.co.za>, Thomas Knoesen <tomknoesen@icloud.com>, Makoma Lekalakala <makoma@earthlife.org.za>, Makoma Lekalakala (Secretary) <seccp@earthlife.org.za>, Dineo Leserwane <leserwaned@taologatsewe.gov.za>, Cecilia Loubser <johanloubser02@gmail.com>, Vuyo Mahlali <info@afasa.org.za>, Moses Mahunonyane <mahunonyanem@dws.gov.za>, Nozizwe Makgalemele <nozizwe.makgalemele@drdlr.gov.za>, Jacoline Mans <jacolinema@daff.gov.za>, Mashudu Marubini <mashuduma@daff.gov.za>, Simphiwe Masilela <simphiwem@atns.co.za>, Pheladi Masipa <pheladi.masipa@energy.gov.za>, Brenda Mayer <brenda.meyer@angloamerican.com>, Alberto Meyer <alberto@abcr.co.za>, Magdalena Michalowska <m.michalowska@buildingenergy.it>, Tshidi Moatshe <tshidim@sacci.org.za>, Precious Mocumi <precious.mocumi@dmr.co.za>, Noa Modukanene <noa@mduxics.co.za>, Zini Mokhine <zini@earthlife.org.za>	
Subject: Reminder: Hyperion EIA 1 & 2 - Environmental Impact Assessment Reports review & comment periods ending soon soon	
<p>Body: HYPERION SOLAR DEVELOPMENTS 1 AND 2 AND ASSOCIATED INFRASTRUCTURE, KATHU, NORTHERN CAPE PROVINCE</p> <p style="text-align: center;">DEA Ref.No.: Hyperion PV1 - 14/12/16/3/3/2/1109</p> <p style="text-align: center;">DEA Ref.No.: Hyperion PV2 - 14/12/16/3/3/2/1110</p> <p>Dear Stakeholders,</p> <p>With reference to our e-mail communication below, this e-mail serves to inform you that the review and comment period for written submission for the draft Environmental Impact Assessment Reports ends on Friday, 10 May 2019.</p> <p>We would like to thank those who already submitted their written comments and <u>urge</u> those who had not yet done so, to please submit their written comments by Friday, 10 May 2019, before close of business.</p> <p>Kind regards,</p> <p>Nicolene Venter</p> <p>Public Participation and Social Consultant Savannah Environmental (Pty) Ltd Tel: +27 (0)11 656 3237 Fax: +27 (0)86 684 0547</p> <p><i>SAWEA Award for Leading Environmental Consultant for Wind Projects in 2013 & 2015</i></p>	

Search

> Date Sent: 03/04/2019 17:35
 > To: nicolene@savannahsa.com, mabel@savannahsa.com
 > Cc:
 > Subject: NOTIFICATION OF AVAILABILITY OF EIARs AND INVITATION TO PUBLIC MEETING: Hyperion PV1 and PV2 near Kathu
 >

ENVIRONMENTAL IMPACT ASSESSMENT FOR THE HYPERION SOLAR DEVELOPMENTS 1 AND 2 AND ASSOCIATED INFRASTRUCTURE, KATHU, NORTHERN CAPE PROVINCE

- **DEA Ref.No.: Hyperion PV1 - 14/12/16/3/3/2/1109**
- **DEA Ref.No.: Hyperion PV2 - 14/12/16/3/3/2/1110**

Dear Stakeholder and/or Interested and Affected Party,

Please find attached letter notifying you of the availability of the Environmental Impact Assessment Reports for the above-mentioned projects for your review and comment. The review and comment period is from **Friday, 05 April 2019** to **Friday, 10 May 2019** and we are looking forward to receive your written comments.

The letter also invites you to the Public Meeting taking place as follows:

- DATE:** Tuesday, 09 April 2019
- TIME:** 18h00 (registration from 17h30)
- VENUE:** Gamagara Hall, Cnr Hendrik van Eck Road and Frikkie Meyer Street, Kathu

The purpose of inviting the public meeting is to present the following:

- brief background to the proposed projects;
- an overview of the Environmental Impact Assessment process followed;
- summary of the key environmental findings as documented in the Environmental Impact Assessment Report;
- an opportunity to seek clarity and raise comments; and
-

Kind regards,

Search

 Show Plain TextAttachments: [Hyperion EIARs 1&2 Availability & PM inviteLetter FINAL.pdf](#)

Activities

 (0 - 0 of 0)

Subject	Status	Contact	Due Date	Assigned User
No Data				

Attachments

 (1 - 1 of 1)

Subject	Contact	Last Modified	
 Hyperion EIARs 1&2 Availability & PM inviteLetter FINAL.pdf		06/05/2019 08:23	<input type="button" value="edit"/>

Accounts

 (0 - 0 of 0)

Account Name	Town/City	Phone
No Data		

Contacts

 (0 - 0 of 0)

Name	Organisation	Email
No Data		

Email Stakeholders

 (1 - 10 of 58)

Name	Organisation	Email	
Abe Abrahams	Department of Water and Sanitation	franksl@dwa.gov.za	<input type="button" value="edit"/>
Nicole Abrahams	South African National Roads Agency Limited	Abrahamsn@nra.co.za	<input type="button" value="edit"/>
Amanda Bester	Telkom SA SOC Ltd	WayleaCR@telkom.co.za	<input type="button" value="edit"/>
Lebo Bitsangk	Gamagara Local Municipality	bitsangk@gamagara.gov.za	<input type="button" value="edit"/>
Jerome Bob	Gamagara Local Municipality	jerome@gamagara.co.za	<input type="button" value="edit"/>
Jim Bredenkamp	Agri SA	jim@jimpos.co.za	<input type="button" value="edit"/>
Jan Burger		burgerlb@gmail.com	<input type="button" value="edit"/>
Linda Burger		burgerlb@gmail.com	<input type="button" value="edit"/>
Sarel Jacobus (sakkie) Burger		burgersarel7@gmail.com	<input type="button" value="edit"/>
Schalk Burger	PNP Trust	pnpvoerkrale@gmail.com	<input type="button" value="edit"/>

Users

Reminder: EIARs Review and Comment Period Ending: Hyperion Solar Developm

Search



Forward

Assigned to: Savannah Public Process

Date Sent: 10/05/2019 06:48

Teams: Global

Project: Hyperion Solar Kathu, Northern Cape

From: Savannah Public Process <publicprocess@savannahsa.com>

To: nicolene@savannahsa.com, mabel@savannahsa.com

Cc:

Bcc: **Abe Abrahams <franksl@dwa.gov.za>** Nicole Abrahams <abrahamsn@nra.co.za>, Amanda Bester <wayleacr@telkom.co.za>, Lebo Bitsangk <bitsangk@gamagara.gov.za>, Jerome Bob <jerome@gamagara.co.za>, Jim Bredenkamp <jim@jimpos.co.za>, Jan Burger <burgerlb@gmail.com>, Sarel Jacobus (sakkie) Burger <burgersarel7@gmail.com>, Schalk Burger <pnpvoerkrale@gmail.com>, Thoko Buthelezi <thokob@daff.gov.za>, Thabo Chaka <thabo.chaka@gmail.com>, Shaun Cloete <cloetes@dws.gov.za>, Get Coetzee <gcoetzee@volksblad.com>, Ina Coetzer <jancoetzer@egate.co.za>, Karen de Bruyn <eia@g7energies.com>, Samantha De la Fontaine <sdelafontaine@gmail.com>, Janine De Wee <deweelj@gamagara.gov.za>, Bryan Fisher <bfisher@ncpg.gov.za>, Simon Gear <advocacy@birdlife.org.za>, John Geeringh <john.geeringh@eskom.co.za>, Henrietta Hager <hager.henri@gmail.com>, Sharief Harris <s.harris@buildingenergy.it>, Natasha Higgitt <nhiggitt@sahra.org.za>, Thokozani Hlophe <thokozani.hlophe@angloamerican.com>, Constant Hoogstad <constanth@ewt.org.za>, Nicol Jansen <henning@agrink.co.za>, Charlotte Joseph <josephc@gamagara.co.za>, Thomas Knoesen <tomknoesen@icloud.com>, Makoma Lekalakala <makoma@earthlife.org.za>, Makoma Lekalakala (Secretary) <seccp@earthlife.org.za>, Dineo Leserwane <leserwaned@taologatsewe.gov.za>, Cecilia Loubser <johanloubser02@gmail.com>, Vuyo Mahlali <info@afasa.org.za>, Moses Mahunonyane <mahunonyanem@dws.gov.za>, Nozizwe Makgalemele <nozizwe.makgalemele@drdlr.gov.za>, Jacoline Mans <jacolinema@daff.gov.za>, Mashudu Marubini <mashuduma@daff.gov.za>, Simphiwe Masilela <simphiwem@atns.co.za>, Pheladi Masipa <pheladi.masipa@energy.gov.za>, Brenda Mayer <brenda.meyer@angloamerican.com>, Alberto Meyer <alberto@abcr.co.za>, Magdalena Michalowska <m.michalowska@buildingenergy.it>, Tshidi Moatshe <tshidim@sacci.org.za>, Precious Mocumi <precious.mocumi@dmr.co.za>, Noa Modukanene <noa@mduxics.co.za>, Zini Mokhine <zini@earthlife.org.za>, MG Molale <mayorsec@taologatsewe.gov.za>

Subject: Reminder: EIARs Review and Comment Period Ending: Hyperion Solar Developments 1 & 2

Body: **HYPERION SOLAR DEVELOPMENT 1 AND HYPERION SOLAR DEVELOPMENT 2 AND ASSOCIATED INFRASTRUCTURE, KATHU, NORTHERN CAPE PROVINCE**

DEA Ref.No.: Hyperion PV1 - 14/12/16/3/3/2/1109

DEA Ref.No.: Hyperion PV2 - 14/12/16/3/3/2/1110

Dear Stakeholder and/or Interested and Affected Party,

This e-mail serves to inform you that the review and comment period for the draft EIARs is ending **today**, Friday, 10 May 2019 at close of business.

We would like to thank those who already submitted their written comments.

Those who had not yet done so, please submit your written comment/s by close of business day **today**, **Friday, 10 May 2019**.

Kind regards,

Nicolene Venter

Public Participation and Social Consultant | Savannah Environmental (Pty) Ltd

Tel: +27 (0)11 656 3237 | Fax: +27 (0)86 684 0547

SAWEA Award for Leading Environmental Consultant for Wind Projects in 2013 & 2015

> From: Savannah Public Process

> Date Sent: 06/05/2019 08:23

> To: nicolene@savannahsa.com, mabel@savannahsa.com

> Cc:

> Subject: Reminder: Hyperion EIA 1 & 2 - Environmental Impact Assessment Reports review & comment periods ending soon soon

>

publicprocess

From: publicprocess <publicprocess@savannahsa.com>
Sent: Monday, May 6, 2019 11:17 AM
To: 'Memela Nokulunga (KBY)'
Cc: 'mabel@savannahsa.com'
Subject: RE: Message from KM_C364e

Dear Nokulunga,

Would you please be so kind and enquire from Mr Mahunoyane whether separate written comments will be submitted for PV 1, PV 2 and PV 3?

Kind regards,

Nicolene Venter

Public Participation & Social Consultant | Savannah Environmental (Pty) Ltd
Tel: +27 (0)11 656 3237 | Fax: +27 (0)86 684 0547

[SAWEA Award for Leading Environmental Consultant for Wind Projects in 2013 & 2015](#)

From: Memela Nokulunga (KBY) <MemelaN@dws.gov.za>
Sent: Monday, May 6, 2019 9:42 AM
To: publicprocess@savannahsa.com
Subject: FW: Message from KM_C364e

Good day,

Please find the attached comments.

Kind regards
Nokulunga Memela
053 836 7610

From: Thebe Setshego(KBY)
Sent: Monday, 06 May 2019 9:25 AM
To: Memela Nokulunga (KBY)
Subject: FW: Message from KM_C364e

Hey Lunga

Please find attached Savannah Environmental letter.

Regards,

*Setshego Thebe
Administrative Officer E-WULAAS
Department of Water and Sanitation
28 Central Road
Beaconsfield
Kimberley
8300
Tel: 053 830 8883*



From: lowervaal@dwa.gov.za [<mailto:lowervaal@dwa.gov.za>]

Sent: 06 May 2019 09:23 AM

To: Thebe Setshego(KBY)

Subject: Message from KM_C364e

DISCLAIMER: This message and any attachments are confidential and intended solely for the addressee. If you have received this message in error, please notify the system manager/sender. Any unauthorized use, alteration or dissemination is prohibited. The Department of Water and Sanitation further accepts no liability whatsoever for any loss, whether it be direct, indirect or consequential, arising from this e-mail, nor for any consequence of its use or storage.

JOHN TAOLO GAETSEWE DISTRIC MUNICIPALITY

04 April 2019

Mr Disang Molaole
Municipal Manager
John Taolo Gaetsewe District Municipality
4 Federale Mynbou Street
KURUMAN
8460

By Courier Services

Dear Mr Molaole,

**HYPERION SOLAR DEVELOPMENTS 1 AND 2 AND ASSOCIATED INFRASTRUCTURE,
KATHU, NORTHERN CAPE PROVINCE
(DEA Ref.No.: Hyperion PV1 - 14/12/16/3/3/2/1109 & DEA Ref.No.: Hyperion PV2 - 14/12/16/3/3/2/1110)**

NOTIFICATION OF AVAILABILITY OF ENVIRONMENTAL IMPACT ASSESSMENT REPORTS FOR REVIEW

The development of two (2) separate photovoltaic (PV) solar energy facilities (SEFs) as well as associated infrastructure are being proposed on the Remaining Extent of the Farm Lyndoch 432 situated approximately 16km north of Kathu in the Northern Cape Province. The proposed SEFs fall within the jurisdiction of the Gamagara Local Municipality and within the greater John Taolo Gaetsewe District Municipality. These facilities are called:

- » Hyperion Solar Development 1; and
- » Hyperion Solar Development 2;

This letter serves to inform you that the Environmental Impact Assessment Reports (EIARs) are available for your Municipality's review and written comments, and a CD containing the EIARs is included in this envelope.

Please note that the EIARs review period is from **Friday, 5 April 2019** to **Friday, 10 May 2019** and we are looking forward receiving your Municipality's written comment on the EIARs before or on the closing date of the review period.

Kind regards



NICOLENE VENTER
Public Participation and Social Consultant
E-mail: publicprocess@savannahsa.com

Reminder: Hyperion EIA 1 & 2 - Environmental Impact Assessment Reports review & comment periods ending soon Search

Forward

Assigned to:	Savannah Public Process	Date Sent:	06/05/2019 08:27
Teams:	Global	Project:	Hyperion Solar Kathu, Northern Cape
From:	Savannah Public Process <publicprocess@savannahsa.com>		
To:	nicolene@savannahsa.com, mabel@savannahsa.com		
Cc:			
Bcc:	MG Molale <mayorsec@taologaetsewe.gov.za>, Disang Molaole <dmolaole@taologaetsewe.gov.za>, Johanna Morobane <johannam@atns.co.za>, Sofia Mosikatse <mosikatses@taologaetsewe.gov.za>, Andre Mostert <andrem@gamagara.co.za>, Philani Msimango <msimangop@dws.gov.za>, Alan Mukoki <alanm@sacci.org.zasta>, Roxanne Mustard <roxannem@l2b.co.za>, Kevin Mutheiwana <mmboneni.mutheiwana@dmr.gov.za>, Henning Myburgh <henning@agrink.co.za>, Jurie Nel <jurie.nel@angloamerican.com>, Kagiso Ositang <ositangk@gamagara.co.za>, Lecrecia Prins <lecrecia.prins@volksblad.com>, Samantha Ralston-Paton <energy@birdlife.org.za>, Jaco Roelofse <roelofse.j@vodamail.co.za>, Shadrack Seleke <moreengs@gamagara.co.za>, Leonard Shaw <shawls@telkom.co.za>, Steven Shibambu <shibambus@dws.gov.za>, Gerrit Spangenberg <spanlab@lantic.net>, Nico Steyn <licosim@gmail.com>, Lizell Stroh <strohl@caa.co.za>, Elsabe Swart <elsabe.dtec@gmail.com>, Tristen Taylor <tristen@earthlife.org.za>, Ratha Andrew Timothy <ratha.timothy@gmail.com>, Adrian Tiplady <atiplady@ska.ac.za>, T Tongwane <mmsec@taologaetsewe.gov.za>, Stanley Tshitwamulomoni <stanleyt@environment.gov.za>, Andrea van Gensen <vgenseal@eskom.co.za>, Karl van Heerden <kv@coatings.co.za>, Andrè van Heerden <alvhvla@gmail.com>, Hendrik Venter <carmel@vodamail.co.za>, Werner Voigt <werner.voigt@angloamerican.com>, Johan Vorster <jacqueline.vorster@yahoo.com>, Albert Wadi <albertw@sacci.org.za>, John Wesson <jnbadm@wessa.co.za>, Lt. Col. Kebasenosi Zondi <kebasenosi@yahoo.com>		
Subject:	Reminder: Hyperion EIA 1 & 2 - Environmental Impact Assessment Reports review & comment periods ending soon		
Body:	<p style="text-align: center;">HYPERION SOLAR DEVELOPMENTS 1 AND 2 AND ASSOCIATED INFRASTRUCTURE, KATHU, NORTHERN CAPE PROVINCE</p> <p style="text-align: center;">DEA Ref.No.: Hyperion PV1 - 14/12/16/3/3/2/1109</p> <p style="text-align: center;">DEA Ref.No.: Hyperion PV2 - 14/12/16/3/3/2/1110</p> <p>Dear Stakeholders,</p> <p>With reference to our e-mail communication below, this e-mail serves to inform you that the review and comment period for written submission for the draft Environmental Impact Assessment Reports ends on Friday, 10 May 2019.</p> <p>We would like to thank those who already submitted their written comments and <u>urge</u> those who had not yet done so, to please submit their written comments by Friday, 10 May 2019, before close of business.</p>		

Nicolene Venter

Search

Public Participation and Social Consultant | Savannah Environmental (Pty) Ltd
Tel: +27 (0)11 656 3237 | Fax: +27 (0)86 684 0547

SAWEA Award for Leading Environmental Consultant for Wind Projects in 2013 & 2015

> From: Savannah Public Process
> Date Sent: 03/04/2019 17:38
> To: nicolene@savannahsa.com, mabel@savannahsa.com
> Cc:
> Subject: NOTIFICATION OF AVAILABILITY OF EIARs AND INVITATION TO PUBLIC MEETING: Hyperion PV1 and PV2 near Kathu
>

ENVIRONMENTAL IMPACT ASSESSMENT FOR THE HYPERION SOLAR DEVELOPMENTS 1 AND 2 AND ASSOCIATED INFRASTRUCTURE, KATHU, NORTHERN CAPE PROVINCE

- **DEA Ref.No.: Hyperion PV1 - 14/12/16/3/3/2/1109**
- **DEA Ref.No.: Hyperion PV2 - 14/12/16/3/3/2/1110**

Dear Stakeholder and/or Interested and Affected Party,

Please find attached letter notifying you of the availability of the Environmental Impact Assessment Reports for the above-mentioned projects for your review and comment. The review and comment period is from **Friday, 05 April 2019** to **Friday, 10 May 2019** and we are looking forward to receive your written comments.

The letter also invites you to the Public Meeting taking place as follows:

DATE: Tuesday, 09 April 2019

TIME: 18h00 (registration from 17h30)

The purpose of inviting the public meeting is to present the following:

Search

- brief background to the proposed projects;
- an overview of the Environmental Impact Assessment process followed;
- summary of the key environmental findings as documented in the Environmental Impact Assessment Report;
- an opportunity to seek clarity and raise comments; and
- an opportunity to liaise with the project team members.

Kind regards,

Nicolene Venter

Public Participation and Social Consultant | Savannah Environmental (Pty) Ltd
Tel: +27 (0)11 656 3237 | Fax: +27 (0)86 684 0547

SAWEA Award for Leading Environmental Consultant for Wind Projects in 2013 & 2015

Show Plain Text

Attachments: [Hyperion EIARs 1&2 Availability & PM inviteLetter FINAL.pdf](#)

Activities

Subject	Status	Contact	Due Date	Assigned User
No Data				

Attachments

Subject	Contact	Last Modified
Hyperion EIARs 1&2 Availability & PM inviteLetter		06/05/2019

Reminder: EIARs Review and Comment Period Ending: Hyperion Solar Developments 1 & 2

Search

Forward

Assigned to:	Savannah Public Process	Date Sent:	10/05/2019 06:52
Teams:	Global	Project:	Hyperion Solar Kathu, Northern Cape
From:	Savannah Public Process <publicprocess@savannahsa.com>		
To:	nicolene@savannahsa.com, mabel@savannahsa.com		
Cc:			
Bcc:	<div style="border: 1px solid red; display: inline-block; padding: 2px;">Disang Molaole <dmolaole@taologaetsewe.gov.za></div> Johanna Morobane <johannam@atns.co.za>, Sofia Mosikatse <mosikatses@taologaetsewe.gov.za>, Andre Mostert <andrem@gamagara.co.za>, Philani Msimango <msimangop@dws.gov.za>, Alan Mukoki <alanm@sacci.org.zasta>, Kevin Mutheiwana <mmboneni.mutheiwana@dmr.gov.za>, Henning Myburgh <henning@agrink.co.za>, Jurie Nel <jurie.nel@angloamerican.com>, Kagiso Ositang <ositangk@gamagara.co.za>, Lecrecia Prins <lecrecia.prins@volksblad.com>, Samantha Ralston-Paton <energy@birdlife.org.za>, Jaco Roelofse <roelofse.j@vodamail.co.za>, Shadrack Seleke <moreengs@gamagara.co.za>, Leonard Shaw <shawls@telkom.co.za>, Steven Shibambu <shibambus@dws.gov.za>, Gerrit Spangenberg <spanlab@lantic.net>, Nico Steyn <licosim@gmail.com>, Lizell Stroh <strohl@caa.co.za>, Elsabe Swart <elsabe.dtec@gmail.com>, Tristen Taylor <tristen@earthlife.org.za>, Ratha Andrew Timothy <ratha.timothy@gmail.com>, Adrian Tiplady <atiplady@ska.ac.za>, T Tongwane <mmsec@taologaetsewe.gov.za>, Stanley Tshitwamulomoni <stanleyt@environment.gov.za>, Andrea van Gensen <vgenseal@eskom.co.za>, Karl van Heerden <kv@coatings.co.za>, André van Heerden <alvhvla@gmail.com>, Hendrik Venter <carmel@vodamail.co.za>, Werner Voigt <werner.voigt@angloamerican.com>, Johan Vorster <jacqueline.vorster@yahoo.com>, Albert Wadi <albertw@sacci.org.za>, John Wesson <jnbadm@wessa.co.za>, Lt. Col. Kebasenosi Zondi <kebasenosi@yahoo.com>		
Subject:	Reminder: EIARs Review and Comment Period Ending: Hyperion Solar Developments 1 & 2		
Body:	<p style="text-align: center;">HYPERION SOLAR DEVELOPMENT 1 AND HYPERION SOLAR DEVELOPMENT 2 AND ASSOCIATED INFRASTRUCTURE, KATHU, NORTHERN CAPE PROVINCE</p> <p style="text-align: center;">DEA Ref.No.: Hyperion PV1 - 14/12/16/3/3/2/1109</p> <p style="text-align: center;">DEA Ref.No.: Hyperion PV2 - 14/12/16/3/3/2/1110</p> <p>Dear Stakeholder and/or Interested and Affected Party,</p> <p>This e-mail serves to inform you that the review and comment period for the draft EIARs is ending today, Friday, 10 May 2019 at close of business.</p> <p>We would like to thank those who already submitted their written comments.</p>		

Nicolene Venter

Public Participation and Social Consultant | Savannah Environmental (Pty) Ltd

Tel: +27 (0)11 656 3237 | Fax: +27 (0)86 684 0547

SAWEA Award for Leading Environmental Consultant for Wind Projects in 2013 & 2015

> From: Savannah Public Process
> Date Sent: 06/05/2019 08:27
> To: nicolene@savannahsa.com, mabel@savannahsa.com
> Cc:
> Subject: Reminder: Hyperion EIA 1 & 2 - Environmental Impact Assessment Reports review & comment periods ending soon
>

**HYPERION SOLAR DEVELOPMENTS 1 AND 2 AND ASSOCIATED
INFRASTRUCTURE, KATHU, NORTHERN CAPE PROVINCE**

DEA Ref.No.: Hyperion PV1 - 14/12/16/3/3/2/1109

DEA Ref.No.: Hyperion PV2 - 14/12/16/3/3/2/1110

Dear Stakeholders,

With reference to our e-mail communication below, this e-mail serves to inform you that the review and comment period for written submission for the draft Environmental Impact Assessment Reports ends on **Friday, 10 May 2019**.

We would like to thank those who already submitted their written comments and urge those who had not yet done so, to please submit their written comments by **Friday, 10 May 2019**, before close of business.

Kind regards,

Nicolene Venter

GAMAGARA LOCAL MUNICIPALITY

04 April 2019

Mr Thusoeng Itumeleng
Municipal Manager
Gamagara Local Municipality
Civic Centre
Cnt Hendrick van Eck & frikkie Meyer Road
KURUMAN 8460

By Courier Services

Dear Mr Itumeleng,

**HYPERION SOLAR DEVELOPMENTS 1 AND 2 AND ASSOCIATED INFRASTRUCTURE,
KATHU, NORTHERN CAPE PROVINCE
(DEA Ref.No.: Hyperion PV1 - 14/12/16/3/3/2/1109 & DEA Ref.No.: Hyperion PV2 - 14/12/16/3/3/2/1110)**

NOTIFICATION OF AVAILABILITY OF ENVIRONMENTAL IMPACT ASSESSMENT REPORTS FOR REVIEW

The development of two (2) separate photovoltaic (PV) solar energy facilities (SEFs) as well as associated infrastructure are being proposed on the Remaining Extent of the Farm Lyndoch 432 situated approximately 16km north of Kathu in the Northern Cape Province. The proposed SEFs fall within the jurisdiction of the Gamagara Local Municipality and within the greater John Taolo Gaetsewe District Municipality. These facilities are called:

- » Hyperion Solar Development 1; and
- » Hyperion Solar Development 2;

This letter serves to inform you that the Environmental Impact Assessment Reports (EIARs) are available for your Municipality's review and written comments, and a CD containing the EIARs is included in this envelope.

Please note that the EIARs review period is from **Friday, 5 April 2019** to **Friday, 10 May 2019** and we are looking forward receiving your Municipality's written comment on the EIARs before or on the closing date of the review period.

Kind regards



NICOLENE VENTER

Public Participation and Social Consultant
E-mail: publicprocess@savannahsa.com

Reminder: Hyperion EIA 1 & 2 - Environmental Impact Assessment Reports review ending soon soon

Search

Forward

Assigned to:	Savannah Public Process	Date Sent:	06/05/2019 08:23
Teams:	Global	Project:	Hyperion Solar Kathu, Northern Cape
From:	Savannah Public Process <publicprocess@savannahsa.com>		
To:	nicolene@savannahsa.com, mabel@savannahsa.com		
Cc:			
Bcc:	<p>Abe Abrahams <franksl@dwa.gov.za>, Nicole Abrahams <abrahamsn@nra.co.za>, Amanda Bester <wayleacr@telkom.co.za>, Lebo Bitsangk <bitsangk@gamagara.gov.za>, Jerome Bob <jerome@gamagara.co.za>, Jim Bredenkamp <jim@jimpos.co.za>, Schalk Burger <pnpvoerkrale@gmail.com>, Linda Burger <burgerlb@gmail.com>, Sarel Jacobus (sakkie) Burger <burgersarel7@gmail.com>, Thoko Buthelezi <thokob@daff.gov.za>, Thabo Chaka <thabo.chaka@gmail.com>, Shaun Cloete <cloetes@dws.gov.za>, Get Coetzee <gcoetzee@volksblad.com>, Ina Coetzer <jancoetzer@egate.co.za>, Karen de Bruyn <eia@g7energies.com>, Samantha De la Fontaine <sdelafontaine@gmail.com>, Janine De Wee <deweelj@gamagara.gov.za>, Bryan Fisher <bfisher@ncpg.gov.za>, Simon Gear <advocacy@birdlife.org.za>, John Geeringh <john.geeringh@eskom.co.za>, Henrietta Hager <hager.henri@gmail.com>, Sharief Harris <s.harris@buildingenergy.it>, Natasha Higgitt <nhiggitt@sahra.org.za>, Thokozani Hlophe <thokozani.hlophe@angloamerican.com>, Constant Hoogstad <constanth@ewt.org.za>, Thusoeng Itumeleng <clementi@gamagara.gov.za>, Nicol Jansen <henning@agrink.co.za>, Charlotte Joseph <josephc@gamagara.co.za>, Thomas Knoesen <tomknoesen@icloud.com>, Makoma Lekalakala <makoma@earthlife.org.za>, Makoma Lekalakala (Secretary) <seccp@earthlife.org.za>, Dineo Leserwane <leserwaned@taologatsewe.gov.za>, Cecilia Loubser <johanloubser02@gmail.com>, Vuyo Mahlati <info@afasa.org.za>, Moses Mahunonyane <mahunonyanem@dws.gov.za>, Nozizwe Makgalemele <nozizwe.makgalemele@drdlr.gov.za>, Jacoline Mans <jacolinema@daff.gov.za>, Mashudu Marubini <mashuduma@daff.gov.za>, Simphiwe Masilela <simphiwem@atns.co.za>, Pheladi Masipa <pheladi.masipa@energy.gov.za>, Brenda Mayer <brenda.meyer@angloamerican.com>, Alberto Meyer <alberto@abcr.co.za>, Magdalena Michalowska <m.michalowska@buildingenergy.it>, Tshidi Moatshe <tshidim@sacci.org.za>, Precious Mocumi <precious.mocumi@dmr.co.za>, Noa Modukanene <noa@mduxics.co.za>, Zini Mokhine <zini@earthlife.org.za></p>		
Subject:	Reminder: Hyperion EIA 1 & 2 - Environmental Impact Assessment Reports review & comment periods ending soon soon		
Body:	<p>HYPERION SOLAR DEVELOPMENTS 1 AND 2 AND ASSOCIATED INFRASTRUCTURE, KATHU, NORTHERN CAPE PROVINCE</p> <p>DEA Ref.No.: Hyperion PV1 - 14/12/16/3/3/2/1109</p> <p>DEA Ref.No.: Hyperion PV2 - 14/12/16/3/3/2/1110</p> <p>Dear Stakeholders,</p> <p>With reference to our e-mail communication below, this e-mail serves to inform you that the review and comment period for written submission for the draft Environmental Impact Assessment Reports ends on Friday, 10 May 2019.</p> <p>We would like to thank those who already submitted their written comments and <u>urge</u> those who had not yet done so, to please submit their written comments by Friday, 10 May 2019, before close of business.</p> <p>Kind regards,</p> <p>Nicolene Venter</p> <p>Public Participation and Social Consultant Savannah Environmental (Pty) Ltd Tel: +27 (0)11 656 3237 Fax: +27 (0)86 684 0547</p> <p><i>SAWEA Award for Leading Environmental Consultant for Wind Projects in 2013 & 2015</i></p>		

Secretary to Munic Manager

Search

> Date Sent: 03/04/2019 17:35
 > To: nicolene@savannahsa.com, mabel@savannahsa.com
 > Cc:
 > Subject: NOTIFICATION OF AVAILABILITY OF EIARs AND INVITATION TO PUBLIC MEETING: Hyperion PV1 and PV2 near Kathu
 >

ENVIRONMENTAL IMPACT ASSESSMENT FOR THE HYPERION SOLAR DEVELOPMENTS 1 AND 2 AND ASSOCIATED INFRASTRUCTURE, KATHU, NORTHERN CAPE PROVINCE

- **DEA Ref.No.: Hyperion PV1 - 14/12/16/3/3/2/1109**
- **DEA Ref.No.: Hyperion PV2 - 14/12/16/3/3/2/1110**

Dear Stakeholder and/or Interested and Affected Party,

Please find attached letter notifying you of the availability of the Environmental Impact Assessment Reports for the above-mentioned projects for your review and comment. The review and comment period is from **Friday, 05 April 2019** to **Friday, 10 May 2019** and we are looking forward to receive your written comments.

The letter also invites you to the Public Meeting taking place as follows:

- DATE:** Tuesday, 09 April 2019
- TIME:** 18h00 (registration from 17h30)
- VENUE:** Gamagara Hall, Cnr Hendrik van Eck Road and Frikkie Meyer Street, Kathu

The purpose of inviting the public meeting is to present the following:

- • brief background to the proposed projects;
- • an overview of the Environmental Impact Assessment process followed;
- • summary of the key environmental findings as documented in the Environmental Impact Assessment Report;
- • an opportunity to seek clarity and raise comments; and
- •

Kind regards,

Search

 Show Plain TextAttachments: [Hyperion EIARs 1&2 Availability & PM inviteLetter FINAL.pdf](#)

Activities

 (0 - 0 of 0)

Subject	Status	Contact	Due Date	Assigned User
No Data				

Attachments

 (1 - 1 of 1)

Subject	Contact	Last Modified	
 Hyperion EIARs 1&2 Availability & PM inviteLetter FINAL.pdf		06/05/2019 08:23	<input type="button" value="edit"/>

Accounts

 (0 - 0 of 0)

Account Name	Town/City	Phone
No Data		

Contacts

 (0 - 0 of 0)

Name	Organisation	Email
No Data		

Email Stakeholders

 (1 - 10 of 58)

Name	Organisation	Email	
Abe Abrahams	Department of Water and Sanitation	franksl@dwa.gov.za	<input type="button" value="edit"/>
Nicole Abrahams	South African National Roads Agency Limited	Abrahamsn@nra.co.za	<input type="button" value="edit"/>
Amanda Bester	Telkom SA SOC Ltd	WayleaCR@telkom.co.za	<input type="button" value="edit"/>
Lebo Bitsangk	Gamagara Local Municipality	bitsangk@gamagara.gov.za	<input type="button" value="edit"/>
Jerome Bob	Gamagara Local Municipality	jerome@gamagara.co.za	<input type="button" value="edit"/>
Jim Bredenkamp	Agri SA	jim@jimpos.co.za	<input type="button" value="edit"/>
Jan Burger		burgerlb@gmail.com	<input type="button" value="edit"/>
Linda Burger		burgerlb@gmail.com	<input type="button" value="edit"/>
Sarel Jacobus (sakkie) Burger		burgersarel7@gmail.com	<input type="button" value="edit"/>
Schalk Burger	PNP Trust	pnpvoerkrale@gmail.com	<input type="button" value="edit"/>

Users

Reminder: EIARs Review and Comment Period Ending: Hyperion Solar Developm

Search



Forward

Assigned to: Savannah Public Process

Date Sent: 10/05/2019 06:48

Teams: Global

Project: Hyperion Solar Kathu, Northern Cape

From: Savannah Public Process <publicprocess@savannahsa.com>

To: nicolene@savannahsa.com, mabel@savannahsa.com

Cc:

Bcc: Abe Abrahams <franksl@dwa.gov.za>, Nicole Abrahams <abrahamsn@nra.co.za>, Amanda Bester <wayleacr@telkom.co.za>, Lebo Bitsangk <bitsangk@gamagara.gov.za>, Jerome Bob <jerome@gamagara.co.za>, Jim Bredenkamp <jim@jimbos.co.za>, Jan Burger <burgerlb@gmail.com>, Sarel Jacobus (sakkie) Burger <burgersarel7@gmail.com>, Schalk Burger <pnpvoerkrake@gmail.com>, Thoko Buthelezi <thokob@daff.gov.za>, Thabo Chaka <thabo.chaka@gmail.com>, Shaun Cloete <cloetes@dws.gov.za>, Get Coetzee <gcoetzee@volksblad.com>, Ina Coetzer <jancoetzer@egate.co.za>, Karen de Bruyn <eia@g7energies.com>, Samantha De la Fontaine <sdelafontaine@gmail.com>, Janine De Wee <deweelj@gamagara.gov.za>, Bryan Fisher <bfisher@ncpg.gov.za>, Simon Gear <advocacy@birdlife.org.za>, John Geeringh <john.geeringh@eskom.co.za>, Henrietta Hager <hager.henri@gmail.com>, Sharief Harris <s.harris@buildingenergy.it>, Natasha Higgitt <nhiggitt@sahra.org.za>, Thokozani Hlophe <thokozani.hlophe@angloamerican.com>, Constant Hoogstad <constanth@ewt.org.za>, Nicol Jansen <henning@agrink.co.za>, Charlotte Joseph <josephc@gamagara.co.za>, Thomas Knoesen <tomknoesen@icloud.com>, Makoma Lekalakala <makoma@earthlife.org.za>, Makoma Lekalakala (Secretary) <seccp@earthlife.org.za>, Dineo Leserwane <leserwaned@taologasetsewe.gov.za>, Cecilia Loubser <johanloubser02@gmail.com>, Vuyo Mahlali <info@afasa.org.za>, Moses Mahunonyane <mahunonyanem@dws.gov.za>, Nozizwe Makgalemele <nozizwe.makgalemele@drdlr.gov.za>, Jacoline Mans <jacolinema@daff.gov.za>, Mashudu Marubini <mashuduma@daff.gov.za>, Simphiwe Masilela <simphiwem@atns.co.za>, Pheladi Masipa <pheladi.masipa@energy.gov.za>, Brenda Mayer <brenda.meyer@angloamerican.com>, Alberto Meyer <alberto@abcr.co.za>, Magdalena Michalowska <m.michalowska@buildingenergy.it>, Tshidi Moatshe <tshidim@sacci.org.za>, Precious Mocumi <precious.mocumi@dmr.co.za>, Noa Modukanene <noa@mduxics.co.za>, Zini Mokhine <zini@earthlife.org.za>, MG Molale <mayorsec@taologasetsewe.gov.za>

Subject: Reminder: EIARs Review and Comment Period Ending: Hyperion Solar Developments 1 & 2

Body: **HYPERION SOLAR DEVELOPMENT 1 AND HYPERION SOLAR DEVELOPMENT 2 AND ASSOCIATED INFRASTRUCTURE, KATHU, NORTHERN CAPE PROVINCE**

DEA Ref.No.: Hyperion PV1 - 14/12/16/3/3/2/1109

DEA Ref.No.: Hyperion PV2 - 14/12/16/3/3/2/1110

Dear Stakeholder and/or Interested and Affected Party,

This e-mail serves to inform you that the review and comment period for the draft EIARs is ending **today**, Friday, 10 May 2019 at close of business.

We would like to thank those who already submitted their written comments.

Those who had not yet done so, please submit your written comment/s by close of business day **today**, **Friday, 10 May 2019**.

Kind regards,

Nicolene Venter

Public Participation and Social Consultant | Savannah Environmental (Pty) Ltd

Tel: +27 (0)11 656 3237 | Fax: +27 (0)86 684 0547

SAWEA Award for Leading Environmental Consultant for Wind Projects in 2013 & 2015

> From: Savannah Public Process

> Date Sent: 06/05/2019 08:23

> To: nicolene@savannahsa.com, mabel@savannahsa.com

> Cc:

> Subject: Reminder: Hyperion EIA 1 & 2 - Environmental Impact Assessment Reports review & comment periods ending soon soon

>

publicprocess

From: publicprocess <publicprocess@savannahsa.com>
Sent: Tuesday, April 23, 2019 8:53 AM
To: 'andrem@gamagara.co.za'
Cc: 'Mabel Qinisile'
Subject: Hyperion PVs 1,2, 3 & 4: Written Comments
Attachments: Hyperion Solar EIA Comments.pdf; Hyperion Solar 1.pdf

Importance: High

Tracking:	Recipient	Read
	'andrem@gamagara.co.za'	
	'Mabel Qinisile'	
	Andre Mostert	Read: 4/23/2019 11:06 AM

Dear Andre,

Thank you for the written comments received.

I would just like to clarify the following:

- Letter Hyperion Solar 1: These comments are only relevant to Solar PV 1
- Letter Hyperion Solar EIA Comments: Are these comments for all four PVs?

Kind regards,

Nicolene Venter
Public Participation & Social Consultant | Savannah Environmental (Pty) Ltd
Tel: +27 (0)11 656 3237 | Fax: +27 (0)86 684 0547

SAWEA Award for Leading Environmental Consultant for Wind Projects in 2013 & 2015

-----Original Message-----

From: Andre Mostert <andrem@gamagara.co.za>
Sent: Tuesday, April 16, 2019 3:05 PM
To: publicprocess <publicprocess@savannahsa.com>
Subject: Re: Hyperion PVs 1,2, 3 & 4: Focus Group Meeting Presentation
Importance: High

Nicolene

Please see my comments regarding these proposed solar plant.

Regards

André Mostert
Manager: Solid Waste &
Environmental Management
Depart Community Services
Gamagara Municipality
P.O. Box 1001 KATHU 8446
Tel: 053-7236000

Fax: 053-7232021
Cell: 082 9065348

Your Choice is Our Childrens Future

--

NOTE: This e-mail, which includes any attachments, is confidential, may be privileged and is intended solely for the use of the named recipient(s). If you are not the intended recipient of this e-mail please immediately notify the sender and delete the e-mail. You may not copy, distribute or disclose the contents of this e-mail to anyone nor take any action in reliance on the content of this e-mail. While we endeavour to exclude viruses from e-mails, neither the sender nor GAMAGARA LOCAL MUNICIPALITY shall incur any liability resulting, directly or indirectly, from accessing any of the attached files, which may contain a virus or the like. No person may conclude a contract on behalf of GAMAGARA LOCAL MUNICIPALITY by e-mail without written authorisation from a duly authorised representative of GAMAGARA LOCAL MUNICIPALITY. Any views expressed in this e-mail are not necessarily those of GAMAGARA LOCAL MUNICIPALITY, in which event GAMAGARA LOCAL MUNICIPALITY accepts no responsibility or liability whatsoever. GAMAGARA LOCAL MUNICIPALITY accepts no responsibility for loss or damages, which may arise from the use of this e-mail as a means of communication."

publicprocess

From: publicprocess <publicprocess@savannahsa.com>
Sent: Tuesday, April 9, 2019 11:40 AM
To: 'andrem@gamagara.co.za'; 'pierreb@gamagara.co.za'; 'dsbuseng@yahoo.com'; 'cvjoseph312@gmail.com'; 'henrieteduplessis95@gmail.com'; 'henryr@gamagara.co.za'; 'kannemeyerg@gamagara.co.za'; 'thupaemangt@gamagara.co.za'; 'ntsielenin@gamagara.co.za'; 'jcchasingo@gamagara.co.za'; 'ositangle@gamagara.co.za'
Cc: 'mabel@savannahsa.com'
Subject: Hyperion PVs 1,2, 3 & 4: Focus Group Meeting Presentation
Attachments: SE2167 EIA Meetings - April 2019.pdf

Importance: High

Tracking:

Recipient

Read

'andrem@gamagara.co.za'

'pierreb@gamagara.co.za'

'dsbuseng@yahoo.com'

'cvjoseph312@gmail.com'

'henrieteduplessis95@gmail.com'

'henryr@gamagara.co.za'

'kannemeyerg@gamagara.co.za'

'thupaemangt@gamagara.co.za'

'ntsielenin@gamagara.co.za'

'jcchasingo@gamagara.co.za'

'ositangle@gamagara.co.za'

'mabel@savannahsa.com'

Andre Mostert

Read: 4/9/2019 2:21 PM

Dear Gamagara Local Municipality Officials,

As promised at this morning's meeting, please find herewith attached your electronic copy of the presentation as presented this morning at the Focus Group Meeting.

Kind regards,

SOUTH AFRICAN DEFENCE FORCE

04 April 2019

Lt Col Keasenosi Zondi
SO1 Military Integrated Environment Management
South African Defence Force
Armcor Building, Block 5, Level 4
Cnr Umgeni and Umfolozi Streets
ERASMUSKLOOF 0001

By Courier Services

Dear Lt Col Zondi,

**HYPERION SOLAR DEVELOPMENTS 1 AND 2 AND ASSOCIATED INFRASTRUCTURE,
KATHU, NORTHERN CAPE PROVINCE**

(DEA Ref.No.: Hyperion PV1 - 14/12/16/3/3/2/1109 & DEA Ref.No.: Hyperion PV2 - 14/12/16/3/3/2/1110)

NOTIFICATION OF AVAILABILITY OF ENVIRONMENTAL IMPACT ASSESSMENT REPORTS FOR REVIEW

The development of two (2) separate photovoltaic (PV) solar energy facilities (SEFs) as well as associated infrastructure are being proposed on the Remaining Extent of the Farm Lyndoch 432 situated approximately 16km north of Kathu in the Northern Cape Province. The proposed SEFs fall within the jurisdiction of the Gamagara Local Municipality and within the greater John Taolo Gaetsewe District Municipality. These facilities are called:

- » Hyperion Solar Development 1; and
- » Hyperion Solar Development 2;

This letter serves to inform you that the Environmental Impact Assessment Reports (EIARs) are available for your Department's review and written comments, and a CD containing the EIARs is included in this envelope.

Please note that the BAR review period is from **Friday, 5 April 2019** to **Friday, 10 May 2019** and we are looking forward receiving your Department's written comment on the BAR before or on the closing date of the review period.

Kind regards



NICOLENE VENTER

Public Participation and Social Consultant

E-mail: publicprocess@savannahsa.com

RETURNED AS UNDELIVERED

Sender to complete yellow areas only



global express

a division of dpd LASER

0861 223 224
www.dawnwing.co.za

WAYBILL



1309086015

FROM: SAVANNAH ENVIRONMENT		Contents		HAZARDOUS YES NO	
Address 5 WOODLANDS DRIVE OFFICE PARK CNR WOODLANDS DR & WESTERN SERVICE ROAD		No. of Parcels 1		PARCEL DETAILS	
City/Country WOODMEAD EXT		Vol(kg)-Ts & C's Apply*		Dimensions (cm)	
Postal Code 2191		40		30	
Sender's Name LISA		1		1	
TO: SOUTH AFRICAN DEFENCE FORCE.		Street Address (P.O. Box Addresses not accepted) Pimsoor Building, Block 5, 40 el. 4. Cnr. Umgeni and Umfelo zi Streets.		Dawn Wing reserves the right to mark the service "Overnight Express" should no service level be selected	
City/Country GASMSUKLOEF		Postal Code must be filled in 2001		Terms strictly 30 days from date of statement	
Receiver's Name Koesenosi Zondi		Date 08/04/19		CASH R PAID YES NO	
By signing this waybill the sender is concluding a contract with Dawn Wing and warrants his authority to enter into this contract and to bind the entity, which he/she represents. The terms and conditions of this contract are contained on the reverse of the sender's copy.		Date 08/04/19		Special Instructions	
Sender's Name Georgina		Date 08/04/19		Filing Ref: SG2167	
Signature [Signature]		Date 08/04/19		SERVICE (mark only one)	
DAWN WING		Date 08/04/19		Special Instructions	
A Division of DPD Laser Express Logistics (Pty) Ltd		Date 08/04/19		SPECIAL INSTRUCTIONS	
Reg. No. 200603333307 VAT No. 4690235280		Date 08/04/19		Tick to select limited liability option (to a maximum amount of R30 000)	
FSP NO 32009		Date 08/04/19		Customs Value ZAR Value of Article	
		Date 08/04/19		Account to be Debited JB6925	
		Date 08/04/19		Sender's Ref. / Bag No.	
		Date 08/04/19		RECEIVED IN GOOD ORDER AND CONDITION	
		Date 08/04/19		Receiver's Signature: [Signature]	
		Date 08/04/19		Print Name: Sizwe	
		Date 08/04/19		Date 08/04/19	
		Date 08/04/19		Time 10:02	

*All weight and dimensions subject to verification through
electronic weight and dimension machine (SABS calibrated)

PROOF OF DELIVERY

SOUTH AFRICAN HERITAGE RESOURCES AGENCY

Hyperion Solar Development 2

[Add new comment](#) [Subscribe to: This post](#) 57 reads

CaseHeader **LocationInfo** **Admin**

Status: SUBMITTED

HeritageAuthority(s): SAHRA
NBKB

Case Type: Section 38 (8) - Statutory Comment Required

Development Type: Solar

ProposalDescription:

Project Name: Hyperion Solar Development 2 **Applicant:** Hyperion Cyraguard (Pty) Ltd **Proposed Activity:** The construction of a photovoltaic (PV) solar energy facility (SEF) with a contracted capacity of up to 75MW. The development footprint will be ~180ha and will include the following infrastructure: » Arrays of PV panels with a capacity of up to 75MW. » Mounting structures to support the PV panels. » Cabling between the project components, to be laid underground where practical. » On-site inverters. » An on-site substation to facilitate connection between each solar energy facility and the Eskom grid. » A new 132kV overhead power line (OHPL) between the on-site substations and the Eskom grid connection point (to be assessed in a separate Basic Assessment process). » Battery storage mechanism with a storage capacity of up to 300MWh. » Water purification plant. » Site Offices and Maintenance Buildings, including workshop areas for maintenance and storage. » Batching plant. » Temporary laydown areas. » Internal access roads and fencing around the development area. The applicant is furthermore proposing to either upgrade the existing T26 gravel road or construct a new access road of the T25 gravel road which will provide access to the project site via the N14. **Location:** The Remaining Extent of the Farm Lyndoch 432 is situated ~16km north of Kathu in the Northern Cape Province. The proposed projects fall within the jurisdiction of the Gamagara Local Municipality and within the greater John Taolo Gaetsewe District Municipality. **Environmental Impact Assessment Process:** In terms of Sections 24 and 24D of the National Environmental Management Act (No 107 of 1998), as read with Government Notice R324 – R327, as amended, a Scoping and Environmental Impact Assessment (EIA) is required for each solar energy facility (SEF). Savannah Environmental is undertaking the required environmental assessment and public participation process for each project.

ApplicationDate: Wednesday, September 26, 2018 - 07:47

CaseID: 12966

Applicants: Cyraguard (Pty) Ltd























Consultants/Experts: Thalita Koster

OtherReferences:

Dept	CaseReference	DueDate	FinalDecision
DEA	14/12/16/3/3/2/1110		

Heritage Reports: Hyperion PV2 - HIA 27.03.19

ReferenceList:

45.  Hyperion PV2 DEIR.pdf
46.  Hyperion PV2 App A - EIA Project Team & Specialist CVs.pdf
47.  Hyperion PV2 App B - Correspondence with Authorities.pdf
48.  Hyperion PV2 App C1 - I&AP Database.pdf
49.  Hyperion PV2 App C2 - Site Notices and Newspaper Advertisement.pdf
50.  Hyperion PV2 App C3 - Background Information Document.pdf
51.  Hyperion PV2 App C4 - Organs of State Correspondence.pdf
52.  Hyperion PV2 App C5 - Stakeholder Correspondence.pdf
53.  Hyperion PV2 App C6 - Comments Received.pdf
54.  Hyperion PV2 App C7 - Minutes of Meetings.pdf
55.  Hyperion PV2 App C8 - Comments and Responses Report.pdf
56.  Hyperion PV2 App D - Ecology Impact Assessment.pdf
57.  Hyperion PV2 App E - Avifauna Impact Assessment.pdf
58.  Hyperion PV2 App F - Watercourse Impact Assessment.pdf
59.  Hyperion PV2 App G - Soils and Agricultural Impact Assessment.pdf
60.  Hyperion PV2 App H - Visual Impact Assessment.pdf
61.  Hyperion PV2 App J - Social Impact Assessment.pdf
62.  Hyperion PV2 App K - EMPr.pdf
63.  Hyperion PV2 App L - EAP Affirmation and Declaration.pdf
64.  Hyperion PV2 App M - Specialist Declaration.pdf
65.  Hyperion PV2 App N - A3 Maps and Coordinates.pdf
66.  Hyperion PV2 App O1 - Services Required.pdf

publicprocess

From: publicprocess <publicprocess@savannahsa.com>
Sent: Wednesday, April 10, 2019 5:44 PM
To: 'Natasha Higgitt'
Cc: 'nicolene@savannahsa.com'; 'mabel@savannahsa.com'
Subject: Hyperion PV1 and PV2: SAHRIS Case IDs

Tracking:	Recipient	Read
	'Natasha Higgitt'	
	'nicolene@savannahsa.com'	
	'mabel@savannahsa.com'	
	Mabel Qinisile	Read: 4/11/2019 8:05 AM

Good Day Natasha,

We can confirm that the Reports have been uploaded and the Case IDs are:

- Hyperion 1 Case ID: **12965**
- Hyperion 2 Case ID: **12966**

Kind regards,

Nicolene Venter

Public Participation & Social Consultant | Savannah Environmental (Pty) Ltd
Tel: +27 (0)11 656 3237 | Fax: +27 (0)86 684 0547

[SAWEA Award for Leading Environmental Consultant for Wind Projects in 2013 & 2015](#)

From: Natasha Higgitt <nhiggitt@sahra.org.za>
Sent: Thursday, April 4, 2019 8:01 AM
To: Savannah Public Process <publicprocess@savannahsa.com>; nicolene@savannahsa.com; mabel@savannahsa.com
Subject: RE: NOTIFICATION OF AVAILABILITY OF EIARs AND INVITATION TO PUBLIC MEETING: Hyperion PV1 and PV2 near Kathu

Good morning,

Thank you for the notification. Please upload the documents to the relevant SAHRIS Case applications and change the status of each case to SUBMITTED. Please inform me when this is completed and reference the SAHRIS Case ID number.

Kind regards,

From: Savannah Public Process <publicprocess@savannahsa.com>
Sent: Wednesday, April 03, 2019 5:36 PM
To: nicolene@savannahsa.com; mabel@savannahsa.com
Subject: NOTIFICATION OF AVAILABILITY OF EIARs AND INVITATION TO PUBLIC MEETING: Hyperion PV1 and PV2 near Kathu

ENVIRONMENTAL IMPACT ASSESSMENT FOR THE HYPERION SOLAR DEVELOPMENTS 1 AND 2 AND ASSOCIATED INFRASTRUCTURE, KATHU, NORTHERN CAPE PROVINCE

- **DEA Ref.No.: Hyperion PV1 - 14/12/16/3/3/2/1109**

- **DEA Ref.No.: Hyperion PV2 - 14/12/16/3/3/2/1110**

Dear Stakeholder and/or Interested and Affected Party,

Please find attached letter notifying you of the availability of the Environmental Impact Assessment Reports for the above-mentioned projects for your review and comment. The review and comment period is from **Friday, 05 April 2019** to **Friday, 10 May 2019** and we are looking forward to receive your written comments.

The letter also invites you to the Public Meeting taking place as follows:

DATE: Tuesday, 09 April 2019
TIME: 18h00 (registration from 17h30)
VENUE: Gamagara Hall, Cnr Hendrik van Eck Road and Frikkie Meyer Street, Kathu

The purpose of inviting the public meeting is to present the following:

- brief background to the proposed projects;
- an overview of the Environmental Impact Assessment process followed;
- summary of the key environmental findings as documented in the Environmental Impact Assessment Report;
- an opportunity to seek clarity and raise comments; and
- an opportunity to liaise with the project team members.

Kind regards,

Nicolene Venter

Public Participation and Social Consultant | Savannah Environmental (Pty) Ltd
Tel: +27 (0)11 656 3237 | Fax: +27 (0)86 684 0547

SAWEA Award for Leading Environmental Consultant for Wind Projects in 2013 & 2015

▪

Natasha Higgitt
Heritage Officer: Archaeology, Palaeontology and Meteorites Unit

South African Heritage Resources Agency
- A nation united through heritage -

T: +27 21 462 4502/ 8660| C:+27 82 507 0378| F:+27 21 462 4509
E: nhiggitt@sahra.org.za | 111 Harrington Street | Cape Town |

www.sahra.org.za

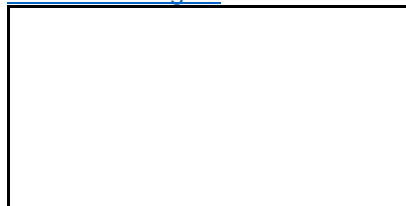

Ngwao-Boswa Ya Kapa Bokone
(Northern Cape Heritage Resources Agency)

04 April 2019

Mr Ratha Andrew Timothy
Heritage Officer
Ngwao-Boswa Ya Kapa Bokone
1 Monridge Office Park
C/o Kekewich Drive & Memorial Road
KIMBERLEY

By Courier Services

Dear Mr Timothy,

**HYPERION SOLAR DEVELOPMENTS 1 AND 2 AND ASSOCIATED INFRASTRUCTURE,
KATHU, NORTHERN CAPE PROVINCE**

(DEA Ref.No.: Hyperion PV1 - 14/12/16/3/3/2/1109 & DEA Ref.No.: Hyperion PV2 - 14/12/16/3/3/2/1110)

NOTIFICATION OF AVAILABILITY OF ENVIRONMENTAL IMPACT ASSESSMENT REPORTS FOR REVIEW

The development of two (2) separate photovoltaic (PV) solar energy facilities (SEFs) as well as associated infrastructure are being proposed on the Remaining Extent of the Farm Lyndoch 432 situated approximately 16km north of Kathu in the Northern Cape Province. The proposed SEFs fall within the jurisdiction of the Gamagara Local Municipality and within the greater John Taolo Gaetsewe District Municipality. These facilities are called:

- » Hyperion Solar Development 1; and
- » Hyperion Solar Development 2;

This letter serves to inform you that the Environmental Impact Assessment Reports (EIARs) are available for your Organisation's review and written comments, and a CD containing the EIARs is included in this envelope.

Please note that the EIARs review period is from **Friday, 5 April 2019** to **Friday, 10 May 2019** and we are looking forward receiving your Organisation's written comment on the EIARs before or on the closing date of the review period.

Kind regards



NICOLENE VENTER

Public Participation and Social Consultant
E-mail: publicprocess@savannahsa.com



0861 223 224
www.dawnwing.co.za



WAYBILL

Source: to complete yellow areas only

FROM: SAVANNAH ENVIRONMENT		Customer: CD	HAZARDOUS YES NO	Filing Ref: 562167
Address: 5 WOODLANDS DRIVE OFFICE PARK CAR WOODLANDS DR 2 WESTERN SERVICE ROAD		PARCEL DETAILS		SERVICE (mark only one)
City/County: WOODMEAD EXT	Postal Code: 2191	No. of Parcels: 1	Weight To & G: 40.30	Dimensions (L x W x H): 1 x 1 x 1
Service Name: LISA	Phone No: 011 6563237	Special Instructions:		Special Instructions:
TO: N Swage-Roswa Jai Kapa Bokone		Dawn Wing reserves the right to mark the service "Overnight Express" should no service level be selected		RECEIVED IN GOOD ORDER AND CONDITION
Street Address (P.O. Box Addresses not accepted): 1 Monridge Office Park, c/o Kekewich Drive & Memorial Road,		Terms strictly 30 days from date of statement		Receiver's Signature: <i>Thapelo</i>
City/County: Kimberley	Postal Code: 8301	CASH AMOUNT R		Print Name: <i>E. Aggrey</i>
Receiver's Name: Rache Timothy	Phone No: 053-831-9537	PAID YES NO		DOB: 05.11.1981
Signature: <i>[Signature]</i>	Collected By: <i>[Signature]</i>	Special Instructions:		PROOF OF DELIVERY

DAWN WING
A Division of DPD Laser Express Logistics (Pty) Ltd
Reg. No. 2006/037352/07 VAT No. 469235260
FSP No 32003

All weight and dimensions subject to verification through electronic weight and dimension machine (SABS calibrated)

Reminder: Hyperion EIA 1 & 2 - Environmental Impact Assessment Reports review & comment periods ending soon

Search

Forward

Assigned to:	Savannah Public Process	Date Sent:	06/05/2019 08:27
Teams:	Global	Project:	Hyperion Solar Kathu, Northern Cape
From:	Savannah Public Process <publicprocess@savannahsa.com>		
To:	nicolene@savannahsa.com, mabel@savannahsa.com		
Cc:			
Bcc:	<p>MG Molale <mayorsec@taologaetsewe.gov.za>, Disang Molaole <dmolaole@taologaetsewe.gov.za>, Johanna Morobane <johannam@atns.co.za>, Sofia Mosikatse <mosikatses@taologaetsewe.gov.za>, Andre Mostert <andrem@gamagara.co.za>, Philani Msimango <msimangop@dws.gov.za>, Alan Mukoki <alanm@sacci.org.zasta>, Roxanne Mustard <roxannem@l2b.co.za>, Kevin Mutheiwana <mmboneni.mutheiwana@dmr.gov.za>, Henning Myburgh <henning@agrink.co.za>, Jurie Nel <jurie.nel@angloamerican.com>, Kagiso Ositang <ositangk@gamagara.co.za>, Lecrecia Prins <lecrecia.prins@volksblad.com>, Samantha Ralston-Paton <energy@birdlife.org.za>, Jaco Roelofse <roelofse.j@vodamail.co.za>, Shadrack Seleke <moreengs@gamagara.co.za>, Leonard Shaw <shawls@telkom.co.za>, Steven Shibambu <shibambus@dws.gov.za>, Gerrit Spangenberg <spanlab@lantic.net>, Nico Steyn <licosim@gmail.com>, Lizell Stroh <strohl@caa.co.za>, Elsabe Swart <elsabe.dtec@gmail.com>, Tristen Taylor <tristen@earthlife.org.za>, Ratha Andrew Timothy <ratha.timothy@gmail.com>, Adrian Tiplady <atiplady@ska.ac.za>, T Tongwane <mmsec@taologaetsewe.gov.za>, Stanley Tshitwamulomoni <stanleyt@environment.gov.za>, Andrea van Gensen <vgenseal@eskom.co.za>, Karl van Heerden <kv@coatings.co.za>, Andrè van Heerden <alvhvla@gmail.com>, Hendrik Venter <carmel@vodamail.co.za>, Werner Voigt <werner.voigt@angloamerican.com>, Johan Vorster <jacqueline.vorster@yahoo.com>, Albert Wadi <albertw@sacci.org.za>, John Wesson <jnbadm@wessa.co.za>, Lt. Col. Kebasenosi Zondi <kebasenosi@yahoo.com></p>		
Subject:	Reminder: Hyperion EIA 1 & 2 - Environmental Impact Assessment Reports review & comment periods ending soon		
Body:	<p style="text-align: center;">HYPERION SOLAR DEVELOPMENTS 1 AND 2 AND ASSOCIATED INFRASTRUCTURE, KATHU, NORTHERN CAPE PROVINCE</p> <p style="text-align: center;">DEA Ref.No.: Hyperion PV1 - 14/12/16/3/3/2/1109</p> <p style="text-align: center;">DEA Ref.No.: Hyperion PV2 - 14/12/16/3/3/2/1110</p> <p>Dear Stakeholders,</p> <p>With reference to our e-mail communication below, this e-mail serves to inform you that the review and comment period for written submission for the draft Environmental Impact Assessment Reports ends on Friday, 10 May 2019.</p> <p>We would like to thank those who already submitted their written comments and <u>urge</u> those who had not yet done so, to please submit their written comments by Friday, 10 May 2019, before close of business.</p>		

Nicolene Venter

Search

Public Participation and Social Consultant | Savannah Environmental (Pty) Ltd
Tel: +27 (0)11 656 3237 | Fax: +27 (0)86 684 0547

SAWEA Award for Leading Environmental Consultant for Wind Projects in 2013 & 2015

> From: Savannah Public Process
> Date Sent: 03/04/2019 17:38
> To: nicolene@savannahsa.com, mabel@savannahsa.com
> Cc:
> Subject: NOTIFICATION OF AVAILABILITY OF EIARs AND INVITATION TO PUBLIC MEETING: Hyperion PV1 and PV2 near Kathu
>

ENVIRONMENTAL IMPACT ASSESSMENT FOR THE HYPERION SOLAR DEVELOPMENTS 1 AND 2 AND ASSOCIATED INFRASTRUCTURE, KATHU, NORTHERN CAPE PROVINCE

- **DEA Ref.No.: Hyperion PV1 - 14/12/16/3/3/2/1109**
- **DEA Ref.No.: Hyperion PV2 - 14/12/16/3/3/2/1110**

Dear Stakeholder and/or Interested and Affected Party,

Please find attached letter notifying you of the availability of the Environmental Impact Assessment Reports for the above-mentioned projects for your review and comment. The review and comment period is from **Friday, 05 April 2019** to **Friday, 10 May 2019** and we are looking forward to receive your written comments.

The letter also invites you to the Public Meeting taking place as follows:

DATE: Tuesday, 09 April 2019

TIME: 18h00 (registration from 17h30)

The purpose of inviting the public meeting is to present the following:

Search

- brief background to the proposed projects;
- an overview of the Environmental Impact Assessment process followed;
- summary of the key environmental findings as documented in the Environmental Impact Assessment Report;
- an opportunity to seek clarity and raise comments; and
- an opportunity to liaise with the project team members.

Kind regards,

Nicolene Venter

Public Participation and Social Consultant | Savannah Environmental (Pty) Ltd
Tel: +27 (0)11 656 3237 | Fax: +27 (0)86 684 0547

SAWEA Award for Leading Environmental Consultant for Wind Projects in 2013 & 2015

Show Plain Text

Attachments: [Hyperion EIARs 1&2 Availability & PM inviteLetter FINAL.pdf](#)

Activities

Subject	Status	Contact	Due Date	Assigned User
No Data				

Attachments

Subject	Contact	Last Modified
Hyperion EIARs 1&2 Availability & PM inviteLetter		06/05/2019

Reminder: EIARs Review and Comment Period Ending: Hyperion Solar Developments 1 & 2

Search

Forward

Assigned to:	Savannah Public Process	Date Sent:	10/05/2019 06:52
Teams:	Global	Project:	Hyperion Solar Kathu, Northern Cape
From:	Savannah Public Process <publicprocess@savannahsa.com>		
To:	nicolene@savannahsa.com, mabel@savannahsa.com		
Cc:			
Bcc:	<p>Disang Molaole <dmolaole@taologasetsewe.gov.za>, Johanna Morobane <johannam@atns.co.za>, Sofia Mosikatse <mosikatses@taologasetsewe.gov.za>, Andre Mostert <andrem@gamagara.co.za>, Philani Msimango <msimangop@dws.gov.za>, Alan Mukoki <alanm@sacci.org.zasta>, Kevin Mutheiwana <mmboneni.mutheiwana@dmr.gov.za>, Henning Myburgh <henning@agrink.co.za>, Jurie Nel <jurie.nel@angloamerican.com>, Kagiso Ositang <ositangk@gamagara.co.za>, Lecrecia Prins <lecrcia.prins@volksblad.com>, Samantha Ralston-Paton <energy@birdlife.org.za>, Jaco Roelofse <roelofse.j@vodamail.co.za>, Shadrack Seleke <moreengs@gamagara.co.za>, Leonard Shaw <shawls@telkom.co.za>, Steven Shibambu <shibambus@dws.gov.za>, Gerrit Spangenberg <spanlab@lantic.net>, Nico Steyn <licosim@gmail.com>, Lizell Stroh <strohl@caa.co.za>, Elsabe Swart <elsabe.dtec@gmail.com>, Tristen Taylor <tristen@earthlife.org.za>, Ratha Andrew Timothy <ratha.timothy@gmail.com>, Adrian Iplady <atiplady@ska.ac.za>, T Tongwane <mmsec@taologasetsewe.gov.za>, Stanley Tshitwamulomoni <stanleyt@environment.gov.za>, Andrea van Gensen <vgenseal@eskom.co.za>, Karl van Heerden <kv@coatings.co.za>, André van Heerden <alvhvla@gmail.com>, Hendrik Venter <carmel@vodamail.co.za>, Werner Voigt <werner.voigt@angloamerican.com>, Johan Vorster <jacqueline.vorster@yahoo.com>, Albert Wadi <albertw@sacci.org.za>, John Wesson <jnbadm@wessa.co.za>, Lt. Col. Kebasenosi Zondi <kebasenosi@yahoo.com></p>		
Subject:	Reminder: EIARs Review and Comment Period Ending: Hyperion Solar Developments 1 & 2		
Body:	<p style="text-align: center;">HYPERION SOLAR DEVELOPMENT 1 AND HYPERION SOLAR DEVELOPMENT 2 AND ASSOCIATED INFRASTRUCTURE, KATHU, NORTHERN CAPE PROVINCE</p> <p style="text-align: center;">DEA Ref.No.: Hyperion PV1 - 14/12/16/3/3/2/1109</p> <p style="text-align: center;">DEA Ref.No.: Hyperion PV2 - 14/12/16/3/3/2/1110</p> <p>Dear Stakeholder and/or Interested and Affected Party,</p> <p>This e-mail serves to inform you that the review and comment period for the draft EIARs is ending today, Friday, 10 May 2019 at close of business.</p> <p>We would like to thank those who already submitted their written comments.</p>		

Nicolene Venter

Public Participation and Social Consultant | Savannah Environmental (Pty) Ltd

Tel: +27 (0)11 656 3237 | Fax: +27 (0)86 684 0547

SAWEA Award for Leading Environmental Consultant for Wind Projects in 2013 & 2015

> From: Savannah Public Process
> Date Sent: 06/05/2019 08:27
> To: nicolene@savannahsa.com, mabel@savannahsa.com
> Cc:
> Subject: Reminder: Hyperion EIA 1 & 2 - Environmental Impact Assessment Reports review
& comment periods ending soon
>

**HYPERION SOLAR DEVELOPMENTS 1 AND 2 AND ASSOCIATED
INFRASTRUCTURE, KATHU, NORTHERN CAPE PROVINCE**

DEA Ref.No.: Hyperion PV1 - 14/12/16/3/3/2/1109

DEA Ref.No.: Hyperion PV2 - 14/12/16/3/3/2/1110

Dear Stakeholders,

With reference to our e-mail communication below, this e-mail serves to inform you that the review and comment period for written submission for the draft Environmental Impact Assessment Reports ends on **Friday, 10 May 2019**.

We would like to thank those who already submitted their written comments and urge those who had not yet done so, to please submit their written comments by **Friday, 10 May 2019**, before close of business.

Kind regards,

Nicolene Venter