

CORRESPONDENCE BEFORE NOTIFICATION OF
ENVIRONMENTAL IMPACT ASSESSMENT
PROCESS AND PUBLIC PARTICIPATION
PROCESS

Nicolene Venter

From: Gamagara Local Municipality <webmaster@mosima.co.za>
Sent: Wednesday, September 19, 2018 2:43 AM
To: nicolene@savannahsa.com
Subject: Copy of: Request for Head of Departments Contact Details

This is a copy of the following message you sent to Website Master via Gamagara Local Municipality

This is an enquiry email via <http://www.gamagara.gov.za/> from:
Nicolene Venter <nicolene@savannahsa.com>

Dear Sir / Madam,

Savannah Environmental has been appointed as the independent Environmental Assessment Practitioner to conduct the Environmental Impact Assessment for four (4) proposed Hyperion PV Solar Energy Projects near Kathu, Northern Cape Province.

It will be greatly appreciated if you can forward us the names and contact details (telephone numbers & e-mail addresses) of the various Head of Department / Departmental Managers of Gamagara Local Municipality i.e.:

- Planning Department
- Local Economic Development Department
- Environmental
- Waste
- Roads and Infrastructure
- Technical
- Electricity
- etc.

Information regarding the Ward Councillors (names & contact details - telephone numbers & e-mail addresses) would also be appreciated.

According to the EIA Regulations these are the stakeholders whom we need to notify of the proposed project within Gamagara Local Municipality.

Kind regards
Nicolene Venter
Public Participation Practitioner
Hyperion PV EIAs

NOTIFICATION OF ENVIRONMENTAL IMPACT
ASSESSMENT PROCESS AND PUBLIC
PARTICIPATION PROCESS

21 September 2018

Dear Stakeholder

ENVIRONMENTAL IMPACT ASSESSMENT AND PUBLIC PARTICIPATION PROCESS

HYPERION SOLAR DEVELOPMENTS AND ASSOCIATED INFRASTRUCTURE, NORTHERN CAPE PROVINCE

NOTICE OF ENVIRONMENTAL IMPACT ASSESSMENT PROCESS

The development of four (4) separate photovoltaic (PV) solar energy facilities (SEFs) as well as associated infrastructure are being proposed on the Remaining Extent of the Farm Lyndoch 432 situated ~16km north of Kathu in the Northern Cape Province. The proposed solar energy facilities fall within the jurisdiction of the Gamagara Local Municipality and within the greater John Taolo Gaetsewe District Municipality. These facilities will be called:

- » Hyperion Solar Development 1
- » Hyperion Solar Development 2
- » Hyperion Solar Development 3
- » Hyperion Solar Development 4

Each of the four (4) SEFS will be constructed as separate stand-alone projects, with a separate project development company (or Special Purpose Vehicle (SPV)) as the applicant for each project. The projects are detailed below:

Applicant:	Project Name:	Contracted Capacity:
Hyperion Solar Development 1 (Pty) Ltd	Hyperion Solar Development 1	75MW
Cyraguard (Pty) Ltd	Hyperion Solar Development 2	75MW
Nomispark (Pty) Ltd	Hyperion Solar Development 3	75MW
Nomispan (Pty) Ltd	Hyperion Solar Development 4	75MW

Infrastructure associated with each solar energy facility will include:

- » Arrays of PV panels (static and tracking PV system) with a contracted capacity of up to 75MW.
- » Mounting structures to support the PV panels.
- » Cabling between the project components, to be laid underground where practical.
- » On-site inverters to convert the power from a direct current to an alternating current.
- » An on-site substation to facilitate the connection between the solar energy facility and the Eskom electricity grid.
- » A new 132kV overhead power line (OHPL) between the on-site substation and the existing Ferrum Substation¹.
- » Battery storage mechanism with a storage capacity of up to 300MWh.
- » Water purification plant.
- » Site Offices and Maintenance Buildings, including workshop areas for maintenance and storage.
- » Batching plant.
- » Temporary laydown areas.
- » Internal access roads and fencing around the development area.

The applicant is also proposing the following:

- » Alternative 1 - Upgrade approximately 3,6km of the T26 gravel road between the project site and the N14; or
- » Alternative 2 - The construction of a new access road and the formalisation of an informal access road between the project site and the T25 gravel road, approximately 5km in length.

It is the developer's intention to bid each solar energy facility under the Department of Energy's (DoE) Renewable Energy Independent Power Producer Procurement (REIPPP) Programme. The power generated from each solar energy facility will be sold to Eskom and will feed into the national electricity grid. The development of the facilities will also assist with the achievement of the electricity goals as set out in the Integrated Resources Plan (IRP).

ENVIRONMENTAL IMPACT ASSESSMENT PROCESS

Four (4) separate applications for Environmental Authorisation (EA) will be submitted for each of the proposed Hyperion Solar developments to the National Department of Environmental Affairs (DEA) as the Competent Authority (CA), in accordance with the National Environmental Management Act (No. 107 of 1998) (NEMA) and the provisions of the 2014 Environmental Impact Assessment (EIA) Regulations, as amended on 07 April 2017, published in GNR 324 to GNR 327. The Northern Cape Department of Environment and Nature Conservation (NC DENC) is the Commenting Authority for these applications.

Savannah Environmental (Pty) Ltd has been appointed as the independent Environmental Assessment Practitioner (EAP), responsible for undertaking the impact assessment processes (Scoping and EIA), in order to identify and assess all potential environmental impacts associated with the project for the area as identified, and recommend appropriate mitigation and management

¹ The construction of the 132kV overhead power line will be assessed as part of a separate Basic Assessment process which will consider feasible alternatives for the power line route.

measures in an Environmental Management Programme (EMPr). As part of these environmental studies, Interested and/or Affected Parties (I&APs) will be actively involved through the public participation process.

The department and/or the organisation which you represent has been identified as a commenting authority for the proposed Hyperion Solar Developments. In this regard, please can you provide us with the name and contact details of the relevant contact person at your department who we would liaise with regarding this project. By registering on the project database, you will receive all information relating to the project and will be provided with an opportunity to provide comment and Input into the EIA processes.

Please do not hesitate to contact us should you require additional information and/or clarification regarding the proposed project. Our team welcomes your participation and looks forward to your involvement throughout this process.

Kind regards

Rozanne Els
Savannah Environmental
Email: publicprocess@savannahsa.com

Hyperion Solar - Notice of Environmental Impact Assessment Process

Search

Forward

Assigned to: Savannah Public Process	Date Sent: 21/09/2018 15:19
Teams: Global	Project: Hyperion Solar Kathu, Northern Cape
From: Savannah Public Process <publicprocess@savannahsa.com>	
To:	
Cc: nicolene@savannahsa.com	
Bcc: Johanna Morobane <johannam@atns.co.za>, Simphiwe Masilela <simphiwem@atns.co.za>, Mashudu Marubini <mashuduma@daff.gov.za>, Jacoline Mans <jacolinema@daff.gov.za>, Thoko Buthelezi <thokob@daff.gov.za>, Pheladi Masipa <pheladi.masipa@energy.gov.za>, Wilma Lutsch <wlutsch@environment.gov.za>, Jasper Nieuwoudt <jasper.nieuwoudt@dmr.gov.za>, Nozizwe Makgalemele <nozizwe.makgalemele@drdlr.gov.za>, Abe Abrahams <franksl@dwa.gov.za>, Steven Shibambu <shibambus@dwa.gov.za>, Thusoeng Itumeleng <clementi@gamagara.gov.za>, Ingrid de Koker <ingridd@gamagara.co.za>, Sofia Mosikatse <mosikatses@taologasetsewe.gov.za>, Dineo Leserwane <leserwaned@taologasetsewe.gov.za>, T Tongwane <mmsec@taologasetsewe.gov.za>, Disang Molaole <dmolaole@taologasetsewe.gov.za>, MG Molale <mayorsec@taologasetsewe.gov.za>, Tamai Hore <tamai.hore@nersa.org.za>, Ratha Andrew Timothy <ratha.timothy@gmail.com>, Elsabe Swart <elsabe.dtec@gmail.com>, Bryan Fisher <bfisher@ncpg.gov.za>, Samantha De la Fontaine <sdelafontaine@gmail.com>, Jaco Roelofse <roelofse.j@vodamail.co.za>, Lizell Stroh <strohl@caa.co.za>, Natasha Higgitt <nhiggitt@sahra.org.za>, Nicole Abrahams <abrahamsn@nra.co.za>, Adrian Tiplady <atiplady@ska.ac.za>, Amanda Bester <wayleacr@telkom.co.za>, Leonard Shaw <shawls@telkom.co.za>	
Subject: Hyperion Solar - Notice of Environmental Impact Assessment Process	
Body: Dear Stakeholder,	
<p>The development of four (4) separate photovoltaic (PV) solar energy facilities (SEFs) as well as associated infrastructure are being proposed on the Remaining Extent of the Farm Lyndoch 432 situated ~16km north of Kathu in the Northern Cape Province. The proposed solar energy facilities fall within the jurisdiction of the Gamagara Local Municipality and within the greater John Taolo Gaetsewe District Municipality. These facilities will be called</p> <ul style="list-style-type: none"> » Hyperion Solar Development 1 » Hyperion Solar Development 2 » Hyperion Solar Development 3 » Hyperion Solar Development 4 <p>Kindly refer to the attached Notification letter and Background information document for further details.</p>	

Search

Rozanne Els

Public Participation Co-ordinator | Savannah Environmental (Pty) Ltd

Tel: +27 (0)11 656 3237 | Fax: +27 (0)86 684 0547

SAWEA Award for Leading Environmental Consultant for Wind Projects in 2013 & 2015

Show Plain Text

Attachments: [AFR BID.pdf](#)
[ENG BID.pdf](#)
[Hyperion Solar PV OoS Notification Letter.pdf](#)
[Reply Form.pdf](#)

▼ Activities

▲ Attachments

		(1 - 4 of 4)	
Subject	Contact	Last Modified	
AFR BID.pdf		21/09/2018 15:19	edit
ENG BID.pdf		21/09/2018 15:19	edit
Hyperion Solar PV OoS Notification Letter.pdf		21/09/2018 15:19	edit
Reply Form.pdf		21/09/2018 15:19	edit

▼ Accounts

▼ Contacts

▼ Email Stakeholders

▼ Users

▲ Projects

		(1 - 1 of 1)	
Name	Assigned To	Start Date:	End Date:
Hyperion Solar Kathu, Northern Cape	Gabriele Stein	02/07/2018	02/07/2019

Print ↑ Back to top



Hyperion Solar Development 1

Hyperion Solar Development 1.

Project Name: Hyperion Solar Development 1

Applicant: Hyperion Solar Development 1 (Pty) Ltd

Proposed Activity: The construction of a photovoltaic (PV) solar energy facility (SEF) with a contracted capacity of up to 75MW. The development footprint will be ~180ha and will include the following infrastructure:

savannahsa.com - Array of PV panels with a capacity of up to 75MW

<http://www.savannahsa.com/public-documents/energy-generation/hyperion-solar-development-1/>



Hyperion Solar Development 2

Hyperion Solar Development 2.

Project Name: Hyperion Solar Development 2

Applicant: Cyraguard (Pty) Ltd

Proposed Activity: The construction of a photovoltaic (PV) solar energy facility (SEF) with a contracted capacity of up to 75MW. The development footprint will be ~180ha

<http://www.savannahsa.com/public-documents/energy-generation/hyperion-solar-development-2/>



Hyperion Solar Development 3

Hyperion Solar Development 3

Project Name: Hyperion Solar Development 3

Applicant: Nomispark (Pty) Ltd

Proposed Activity: The construction of a photovoltaic (PV) solar energy facility (SEF) with a contracted capacity of up to 75MW. The development footprint will be ~180ha

<http://www.savannahsa.com/public-documents/energy-generation/hyperion-solar-development-3/>

Hyperion Solar Development 4

Hyperion Solar Development 4.

Project Name: Hyperion Solar Development 4

Applicant: Nomispark (Pty) Ltd

Proposed Activity: The construction of a photovoltaic (PV) solar energy facility (SEF) with a contracted capacity of up to 75MW. The development footprint will be ~180ha

<http://www.savannahsa.com/public-documents/energy-generation/hyperion-solar-development-4/>

NOTIFICATION OF SCOPING REPORT FOR
PUBLIC REVIEW AND COMMENT

25 October 2018

Dear Stakeholder

**ENVIRONMENTAL IMPACT ASSESSMENT AND
 PUBLIC PARTICIPATION PROCESS**

**HYPERION SOLAR DEVELOPMENTS AND ASSOCIATED INFRASTRUCTURE,
 NORTHERN CAPE PROVINCE**

NOTIFICATION OF AVAILABILITY OF SCOPING REPORTS FOR REVIEW

The development of four (4) separate photovoltaic (PV) solar energy facilities (SEFs) as well as associated infrastructure are being proposed on the Remaining Extent of the Farm Lyndoch 432 situated ~16km north of Kathu in the Northern Cape Province. The proposed SEFs fall within the jurisdiction of the Gamagara Local Municipality and within the greater John Taolo Gaetsewe District Municipality. These facilities will be called:

- » Hyperion Solar Development 1;
- » Hyperion Solar Development 2;
- » Hyperion Solar Development 3; and
- » Hyperion Solar Development 4.

Each of the four (4) SEFs will be constructed as separate stand-alone projects, with a separate project development company (or Special Purpose Vehicle) as the applicant for each project. The projects are detailed below:

Applicant:	Project Name:	Contracted Capacity:
Hyperion Solar Development 1 (Pty) Ltd	Hyperion Solar Development 1	75MW
Cyraguard (Pty) Ltd	Hyperion Solar Development 2	75MW
Nomispark (Pty) Ltd	Hyperion Solar Development 3	75MW
Nomispan (Pty) Ltd	Hyperion Solar Development 4	75MW

Infrastructure associated with each solar energy facility will include:

- » Arrays of PV panels (static and tracking PV system) with a contracted capacity of up to 75MW.
- » Mounting structures to support the PV panels.
- » Cabling between the project components, to be laid underground where practical.
- » On-site inverters to convert the power from a direct current to an alternating current.
- » An on-site substation to facilitate the connection between the solar energy facility and the Eskom electricity grid.
- » A new 132kV overhead power line between the on-site substation and the existing Ferrum Substation¹.
- » Battery storage mechanism with a storage capacity of up to 300MWh.
- » Water purification plant.
- » Site Offices and Maintenance Buildings, including workshop areas for maintenance and storage.
- » Batching plant.
- » Temporary laydown areas.
- » Internal access roads and fencing around the development area.

For each facility, the applicant is also proposing an access road to the project site. Two alternatives will be assessed:

- » Alternative 1 - Upgrade approximately 3,6km of the T26 gravel road between the project site and the N14; or
- » Alternative 2 - The construction of a new access road and the formalisation of an informal access road between the project site and the T25 gravel road, approximately 5km in length.

It is the developer's intention to bid each SEF under the Department of Energy's (DoE) Renewable Energy Independent Power Producer Procurement (REIPPP) Programme. The power generated from each SEF will be sold to Eskom and will feed into the national electricity grid. The development of the facilities will also assist with the achievement of the electricity goals as set out in the current Integrated Resources Plan.

ENVIRONMENTAL IMPACT ASSESSMENT PROCESS

Four (4) separate applications for Environmental Authorisation will be submitted for each of the proposed Hyperion Solar developments to the National Department of Environmental Affairs as the Competent Authority, in accordance with the National Environmental Management Act (No. 107 of 1998) and the provisions of the 2014 Environmental Impact Assessment (EIA) Regulations, as amended on 07 April 2017, published in GNR 324 to GNR 327. The Northern Cape Department of Environment and Nature Conservation is the Commenting Authority for these applications.

¹ The construction of the 132kV overhead power line will be assessed as part of a separate Basic Assessment process which will consider feasible alternatives for the power line route.

Savannah Environmental (Pty) Ltd has been appointed as the independent Environmental Assessment Practitioner, responsible for undertaking the impact assessment processes (Scoping and EIA phases), in order to identify and assess all potential environmental impacts associated with the project for the area as identified and recommend appropriate mitigation and management measures in an Environmental Management Programme. As part of these environmental studies, Interested and/or Affected Parties (I&APs) will be actively involved through the public participation process.

AVAILABILITY OF SCOPING REPORTS FOR REVIEW

As a registered Interested and Affected Party (I&AP), you are hereby notified that the Scoping Reports are available for review and comment. The reports can be viewed at the Kathu Public Library (1 Hendrik van Eck Road, Kathu, Northern Cape Province) from **Friday, 26 October 2018** to **Monday, 26 November 2018**. The reports can also be downloaded from the following website: www.savannahsa.com. A password to access the downloads page can be requested from the contact person below.

Please submit written comment on the Scoping Reports by **Monday, 26 November 2018** via fax, post or email to the contact person below. All comments received during this 30-day review period will be recorded and included in the Final Scoping Reports for submission to the National DEA in line with Regulation 44 of the 2014 NEMA EIA Regulations, as amended (GN R326). Please do not hesitate to contact us should you require additional information and / or clarification regarding the projects. Our team welcomes your participation and looks forward to your involvement throughout this process.

Kind regards



Nicolene Venter

Public Participation and Social Consultant

Email: publicprocess@savannahsa.com

Projects Organisations Stakeholders Calendar Reports Emails more

Hyperion Solar Notification of Availability of Scoping Report for public review

Assigned to:	Savannah Public Process	Date Sent:	26/10/2018 13.13
Teams:	Global	Project:	Hyperion Solar Kathu, Northern Cape
From:	Savannah Public Process <publicprocess@savannahsa.com>		
To:			
Cc:	nicolene@savannahsa.com, rozanne@savannahsa.com		
Bcc:	<p>John Wesson <jnbadm@wessa.co.za>, Amanda Bester <wayleacr@telkom.co.za>, Alan Mukoki <alanm@sacci.org.zasta>, Thokozani Hlophe <thokozani.hlophe@angloamerican.com>, Andrea van Gensen <vgenseal@eskom.co.za>, Schalk Burger <pnpvoerkrale@gmail.com>, MG Molale <mayorsec@taologasetsewe.gov.za>, Steven Shibambu <shibambus@dwa.gov.za>, Samantha Ralston-Paton <energy@birdlife.org.za>, Cecilia Loubser <johanloubser02@gmail.com>, Bryan Fisher <bfisher@ncpg.gov.za>, Get Coetzee <gcoetzee@volksblad.com>, Adrian Tiplady <atiplady@ska.ac.za>, Sofia Mosikatse <mosikatses@taologasetsewe.gov.za>, Tristen Taylor <tristen@earthlife.org.za>, Constant Hoogstad <constanth@ewt.org.za>, Henrietta Hager <hager.henri@gmail.com>, Simon Gear <advocacy@birdlife.org.za>, Nico Steyn <licosim@gmail.com>, Kagiso Ositang <ositangk@gamagara.co.za>, Sharief Harris <s.harris@buildingenergy.it>, Nicole Abrahams <abrahamsn@nra.co.za>, Leonard Shaw <shawls@telkom.co.za>, Albert Wadi <albertw@sacci.org.za>, Ingrid de Koker <ingridd@gamagara.co.za>, John Geeringh <john.geeringh@eskom.co.za>, Brenda Mayer <brenda.meyer@angloamerican.com>, Ratha Andrew Timothy <ratha.timothy@gmail.com>, Zini Mokhine <zini@earthlife.org.za>, Veronique Fyfe <eia@g7energies.com>, Kevin Mutheiwana <mmboneni.mutheiwana@dmr.gov.za>, Jaco Roelofse <roelofse.j@vodamail.co.za>, Lt. Cnl. Kebasenosi Zondi <kebasenosi@yahoo.com>, Lizell Stroh <strohl@caa.co.za>, Disang Molaole <dmolaole@taologasetsewe.gov.za>, Philani Msimango <msimangop@dws.gov.za>, Natasha Higgitt <nhiggitt@sahra.org.za>, Karl van Heerden <kv@coatings.co.za>, Makoma Lekalakala (Secretary) <seccp@earthlife.org.za>, Jasper Nieuwoudt <jasper.nieuwoudt@dmr.gov.za>, Johan Vorster <jacqueline.vorster@yahoo.com>, Wilma Lutsch <wlutsch@environment.gov.za>, Karen de Bruyn <karen@g7energies.com>, Nicol Jansen <henning@agrink.co.za>, Lecrecia Prins <lecrecia.prins@volksblad.com>, Jacoline Mans <jacolinema@daff.gov.za>, Andr� van Heerden <alvMa@gmail.com>, Tshidi Moatshe <tshidim@sacci.org.za>, Makoma Lekalakala <makoma@earthlife.org.za>, Thusoeng Itumeleng <clementi@gamagara.gov.za>, Samantha De la Fontaine <sdelafontaine@gmail.com>, Magdalena Michalowska <m.michalowska@buildingenergy.it>, T Tongwane <mmsec@taologasetsewe.gov.za>, Jerome Bob <jerome@gamagara.co.za>, Thomas Knoesen <tomknoesen@icloud.com>, Johanna Morobane <johannam@atns.co.za>, Thoko Buthelezi <thokob@daff.gov.za>, Tamai Hore <tamai.hore@nersa.org.za>, Simphiwe Masilela <simphiwem@atns.co.za>, Nozizwe Makgalemele <nozizwe.makgalemele@drdlr.gov.za>, Gerrit Spangenberg <spanlab@lantic.net>, Abe Abrahams <franksl@dwa.gov.za>, Sarel Jacobus (sakkie) Burger <burgersarel7@gmail.com>, Jurie Nel <jurie.nel@angloamerican.com>, Elsabe Swart <elsabe.dtec@gmail.com>, Mashudu Marubini <mashuduma@daff.gov.za>, Pheladi Masipa <pheladi.masipa@energy.gov.za>, Dineo Leserwane <leserwaned@taologasetsewe.gov.za></p>		
Subject:	Hyperion Solar Notification of Availability of Scoping Report for public review		

Search

The development of four (4) separate photovoltaic (PV) solar energy facilities (SEFs) as well as associated infrastructure are being proposed on the Remaining Extent of the Farm Lyndoch 432 situated ~16km north of Kathu in the Northern Cape Province. The proposed SEFs fall within the jurisdiction of the Gamagara Local Municipality and within the greater John Taolo Gaetsewe District Municipality. These facilities will be called Hyperion Solar Development 1, 2, 3 and 4.

As a registered Interested and Affected Party (I&AP), you are hereby notified that the Scoping Report is available for review and comment. The report can be viewed at the Kathu Public Library (1 Hendrik van Eck Road, Kathu, Northern Cape Province) from **Friday, 26 October 2018 to Monday, 26 November 2018**. The report can also be downloaded from the following website: www.savannahsa.com. A password to access the downloads page can be requested from the contact person below.

Please refer to the attached notification letter for further information.

Kind regards,

Rozanne Els

Public Participation Co-ordinator | Savannah Environmental (Pty) Ltd

Tel: +27 (0)11 656 3237 | Fax: +27 (0)86 684 0547

SAWEA Award for Leading Environmental Consultant for Wind Projects in 2013 & 2015

Show Plain Text

Attachments: [Hyperion Solar PVs-SRs AvailabilityNotificationLetter.pdf](#)

Projects

Name	Assigned To	Start Date	End Date	
Hyperion Solar Kathu, Northern Cape	Gabriele Stein	02/07/2018	02/07/2019	<input type="button" value="edit"/>

Attachments

Subject	Contact	Last Modified	
 Hyperion Solar PVs-SRs AvailabilityNotificationLetter.pdf		26/10/2018 13.13	<input type="button" value="edit"/>

Activities

Accounts

Contacts

DISTRIBUTION OF SCOPING REPORT

SAHRIS

MyDashboard Explore Create Calendar Maps Help

Heritage Cases *Hyperion Solar Development 1* has been updated.

Heritage Cases

VIEW EDIT

Hyperion Solar Development 1

Add new comment Subscribe to: This post 16 reads

CaseHeader LocationInfo Admin

Status: SUBMITTED

HeritageAuthority(s): SAHRA
NKBK

Case Type: Section 38 (8) - Statutory Comment Required

Development Type: Solar

ProposalDescription:

Project Name: Hyperion Solar Development 1 Applicant: Hyperion Solar Development 1 (Pty) Ltd Proposed Activity: The construction of a photovoltaic (PV) solar energy facility (SEF) with a contracted capacity of up to 75MW. The development footprint will be ~100ha and will include the following infrastructure: > Arrays of PV panels with a capacity of up to 75MW. > Mounting structures to support the PV panels. > Cabling between the project components, to be laid underground where practical. > On-site inverters. > An on-site substation to facilitate connection between each solar energy facility and the Eskom grid. > A new 132kV overhead power line (OHL) between the on-site substations and the Eskom grid connection point (to be assessed in a separate Basic Assessment process). > Battery storage mechanism with a storage capacity of up to 300MWh. > Water purification plant. > Site Offices and Maintenance Buildings, including workshop areas for maintenance and storage. > Batching plant. > Temporary laydown areas. > Internal access roads and fencing around the development area. The applicant is furthermore proposing to either upgrade the existing T26 gravel road or construct a

Official Decisions & Comments

Date	DecStatus
03/10/2018	Interim Comment

Like 0

Twitter LinkedIn Facebook

OtherReferences:

ReferenceList:

AdditionalDocuments

1. [Hyperion_AFR BID.pdf](#)
2. [Hyperion_ENG BID.pdf](#)
3. [Hyperion PV 1 DSR.pdf](#)
4. [Hyperion PV1_Appendix A - EIA Project Team and Specialist CVs.pdf](#)
5. [Hyperion PV1_Appendix B- Authority Correspondence.pdf](#)
6. [Hyperion PV1_Appendix C1 - I&AP Database.pdf](#)
7. [Hyperion PV1_Appendix C2 - Site Notices and Newspaper Advertisement.pdf](#)
8. [Hyperion PV1_Appendix C3 - Background Information Document.pdf](#)
9. [Hyperion PV1_Appendix C4 - Organs of State Correspondence.pdf](#)
10. [Hyperion PV1_Appendix C5 - Stakeholder Correspondence.pdf](#)
11. [Hyperion PV1_Appendix C6 - Comments Received.pdf](#)
12. [Hyperion PV1_Appendix C7 - Minutes of Meetings.pdf](#)
13. [Hyperion PV1_Appendix C8 - Comments and Responses Report.pdf](#)
14. [Hyperion PV1_Appendix D - Ecology Impact Assessment.pdf](#)
15. [Hyperion PV1_Appendix E - Avifauna Impact Assessment.pdf](#)
16. [Hyperion PV1_Appendix F - Watercourse Impact Assessment.pdf](#)
17. [Hyperion PV1_Appendix G - Soils and Agricultural Potential.pdf](#)
18. [Hyperion PV1_Appendix H - Visual Impact Assessment.pdf](#)
19. [Hyperion PV1_Appendix I - Heritage and Palaeontological Impact Assessment.pdf](#)
20. [Hyperion PV1_Appendix J - Social Impact Assessment.pdf](#)
21. [Hyperion PV1_Appendix K - EAP Affirmation and Declaration.pdf](#)
22. [Hyperion PV1_Appendix L - Specialist Declarations.pdf](#)
23. [Hyperion PV1_Appendix M - A3 Maps.pdf](#)

SAHRIS

MyDashboard Explore Create Calendar Maps Help

Heritage Cases *Hyperion Solar Development 2* has been updated.

Heritage Cases

VIEW EDIT

Hyperion Solar Development 2

Add new comment Subscribe to: This post 18 reads

CaseHeader LocationInfo Admin

Status: SUBMITTED

HeritageAuthority(s): SAHRA
NBKB

Case Type: Section 38 (8) - Statutory Comment Required

Development Type: Solar

ProposalDescription:

Project Name: Hyperion Solar Development 2 Applicant: Hyperion Cyraguard (Pty) Ltd Proposed Activity: The construction of a photovoltaic (PV) solar energy facility (SEF) with a contracted capacity of up to 75MW. The development footprint will be ~180ha and will include the following infrastructure: > Arrays of PV panels with a capacity of up to 75MW > Mounting structures to support the PV panels. > Cabling between the project components, to be laid underground where practical. > On-site inverters. > An on-site substation to facilitate connection between each solar energy facility and the Eskom grid. > A new 132kV overhead power line (OHPL) between the on-site substations and the Eskom grid connection point (to be assessed in a separate Basic Assessment process). > Battery storage mechanism with a storage capacity of up to 300MWh. > Water purification plant. > Site Offices and Maintenance Buildings, including workshop areas for maintenance and storage. > Batching plant. > Temporary laydown areas. > Internal access roads and fencing around the development area. The applicant is furthermore proposing to either upgrade the existing T26 gravel road or construct a new access

Applicants: Cyraguard (Pty) Ltd

Consultants/Experts: Shaun Taylor

OtherReferences:

ReferenceList:

AdditionalDocuments

- Hyperion_AFR BID.pdf
- Hyperion_ENG BID.pdf
- Hyperion PV 2 DSR.pdf
- Hyperion PV2_Appendix A - EIA Project Team and Specialist CV's.pdf
- Hyperion PV2_Appendix B- Authority Correspondence.pdf
- Hyperion PV2_Appendix C1 - I&AP DDatabase.pdf
- Hyperion PV2_Appendix C2 - Site Notices and Newspaper Advertisement.pdf
- Hyperion PV2_Appendix C3 - Background Information Document.pdf
- Hyperion PV2_Appendix C4 - Organs of State Correspondence.pdf
- Hyperion PV2_Appendix C5 - Stakeholder Correspondence.pdf
- Hyperion PV2_Appendix C6 - Comments Received.pdf
- Hyperion PV2_Appendix C7 - Minutes of Meetings.pdf
- Hyperion PV2_Appendix C8 - Comments and Responses Report.pdf
- Hyperion PV2_Appendix D - Ecological Impact Assessment.pdf
- Hyperion PV2_Appendix E - Avifauna Impact Assessment.pdf
- Hyperion PV2_Appendix F - Watercourse Impact Assessment.pdf
- Hyperion PV2_Appendix G - Soils and Agricultural Potential.pdf
- Hyperion PV2_Appendix H - Visual Impact Assessment.pdf
- Hyperion PV2_Appendix I - Heritage and Palaeontological Impact Assessment.pdf
- Hyperion PV2_Appendix J - Social Impact Assessment.pdf
- Hyperion PV2_Appendix K - EAP Affirmation and Declaration.pdf
- Hyperion PV2_Appendix L - Specialist Declarations.pdf
- Hyperion PV2_Appendix M - A3 Maps.pdf

Back to Top

Official Decisions & Comments

Date	DecStatus
03/10/2018	Interim Comment

Like 0 G+ Tweet in +

SAHRIS

MyDashboard Explore Create Calendar Maps Help

Heritage Cases *Hyperion Solar Development 4* has been updated.

Heritage Cases

VIEW EDIT

Hyperion Solar Development 4

Add new comment Subscribe to: This post 18 reads

CaseHeader LocationInfo Admin

Status: SUBMITTED

HeritageAuthority(s): SAHRA
NBKB

Case Type: Section 38 (8) - Statutory Comment Required

Development Type: Solar

ProposalDescription:

Project Name: Hyperion Solar Development 4 Applicant: Hyperion Nomispan (Pty) Ltd Proposed Activity: The construction of a photovoltaic (PV) solar energy facility (SEF) with a contracted capacity of up to 75MW. The development footprint will be ~180ha and will include the following infrastructure: > Arrays of PV panels with a capacity of up to 75MW > Mounting structures to support the PV panels. > Cabling between the project components, to be laid underground where practical. > On-site inverters. > An on-site substation to facilitate connection between each solar energy facility and the Eskom grid. > A new 132kV overhead power line (OHPL) between the on-site substations and the Eskom grid connection point (to be assessed in a separate Basic Assessment process). > Battery storage mechanism with a storage capacity of up to 300MWh. > Water purification plant. > Site Offices and Maintenance Buildings, including workshop areas for maintenance and storage. > Batching plant. > Temporary laydown areas. > Internal access roads and fencing around the development area. The applicant is furthermore proposing to either upgrade the existing T26 gravel road or construct a new access road of the T25 gravel road which will provide access to the project site via the N14. Location: The Remaining Extent of the

Official Decisions & Comments

Date	DecStatus
03/10/2018	Interim Comment

Like 0 G+ Tweet in +

Hyperion Solar Development 3 (PV) Ltd
Consultants/Experts: Shaun Taylor
OtherReferences:
ReferenceList:

AdditionalDocuments

1. [Hyperion_AFR BID.pdf](#)
2. [Hyperion_ENG BID.pdf](#)
3. [Hyperion PV 4 DSR.pdf](#)
4. [Hyperion PV4_Appendix A - EIA Project Team and Specialist CVs.pdf](#)
5. [Hyperion PV4_Appendix B- Authority Correspondence.pdf](#)
6. [Hyperion PV4_Appendix C1 - I&AP DDatabase.pdf](#)
7. [Hyperion PV4_Appendix C2 - Site Notices and Newspaper Advertisement.pdf](#)
8. [Hyperion PV4_Appendix C3 - Background Information Document.pdf](#)
9. [Hyperion PV4_Appendix C4 - Organs of State Correspondence.pdf](#)
10. [Hyperion PV4_Appendix C5 - Stakeholder Correspondence.pdf](#)
11. [Hyperion PV4_Appendix C6 - Comments Received.pdf](#)
12. [Hyperion PV4_Appendix C7 - Minutes of Meetings.pdf](#)
13. [Hyperion PV4_Appendix C8 - Comments and Responses Report.pdf](#)
14. [Hyperion PV4_Appendix D - Ecological Impact Assessment.pdf](#)
15. [Hyperion PV4_Appendix E - Avifauna Impact Assessment.pdf](#)
16. [Hyperion PV4_Appendix F - Watercourse Impact Assessment.pdf](#)
17. [Hyperion PV4_Appendix G - Soils and Agricultural Potential.pdf](#)
18. [Hyperion PV4_Appendix H - Visual Impact Assessment.pdf](#)
19. [Hyperion PV4_Appendix I - Heritage and Palaeontological Impact Assessment.pdf](#)
20. [Hyperion PV4_Appendix J - Social Impact Assessment.pdf](#)
21. [Hyperion PV4_Appendix K - EAP Affirmation and Declaration.pdf](#)
22. [Hyperion PV4_Appendix L - Specialist Declarations.pdf](#)
23. [Hyperion PV4_Appendix M - A3 Maps.pdf](#)

[Back to Top](#)

[Home](#) [My account](#) [Messages](#) [MyDashboard](#) [MyComments](#) [Log out](#)

SAHRIS

[MyDashboard](#) [Explore](#) [Create](#) [Calendar](#) [Maps](#) [Help](#)

 Heritage Cases *Hyperion Solar Development 3* has been updated.



Heritage Cases

[VIEW](#) [EDIT](#)

Hyperion Solar Development 3

[Add new comment](#) [Subscribe to this post](#) 16 reads

[CaseHeader](#) [LocationInfo](#) [Admin](#)

Status: SUBMITTED

HeritageAuthority(s): SAHRA
NEKB

Case Type: Section 38 (8) - Statutory Comment Required

Development Type: Solar

ProposalDescription:

Project Name: Hyperion Solar Development 3 Applicant: Hyperion Nomispan (Pty) Ltd Proposed Activity: The construction of a photovoltaic (PV) solar energy facility (SEF) with a contracted capacity of up to 75MW. The development footprint will be ~180ha and will include the following infrastructure: > Arrays of PV panels with a capacity of up to 75MW. > Mounting structures to support the PV panels. > Cabling between the project components, to be laid underground where practical. > On-site inverters. > An on-site substation to facilitate connection between each solar energy facility and the Eskom grid. > A new 132kV overhead power line (OHPL) between the on-site substations and the Eskom grid connection point (to be assessed in a separate Basic Assessment process). > Battery storage mechanism with a storage capacity of up to 300MWh. > Water purification plant. > Site Offices and Maintenance Buildings, including workshop areas for maintenance and storage. > Batching plant. > Temporary laydown areas. > Internal access roads and fencing around the development area. The applicant is furthermore proposing to either upgrade the existing T26 gravel road or construct a new access road of the T25 gravel road which will provide access to the project site via the N14. Location: The Remaining Extent of the

Consultants/Experts: Shaun Taylor

OtherReferences:
ReferenceList:

AdditionalDocuments

1. [Hyperion_AFR BID.pdf](#)
2. [Hyperion_ENG BID.pdf](#)
3. [Hyperion PV 3 DSR.pdf](#)
4. [Hyperion PV3_Appendix A - EIA Project Team and Specialist CVs.pdf](#)
5. [Hyperion PV3_Appendix B- Authority Correspondence.pdf](#)
6. [Hyperion PV3_Appendix C1 - I&AP DDatabase.pdf](#)
7. [Hyperion PV3_Appendix C2 - Site Notices and Newspaper Advertisement.pdf](#)
8. [Hyperion PV3_Appendix C3 - Background Information Document.pdf](#)
9. [Hyperion PV3_Appendix C4 - Organs of State Correspondence.pdf](#)
10. [Hyperion PV3_Appendix C5 - Stakeholder Correspondence.pdf](#)
11. [Hyperion PV3_Appendix C6 - Comments Received.pdf](#)
12. [Hyperion PV3_Appendix C7 - Minutes of Meetings.pdf](#)
13. [Hyperion PV3_Appendix C8 - Comments and Responses Report.pdf](#)
14. [Hyperion PV3_Appendix D - Ecological Impact Assessment.pdf](#)
15. [Hyperion PV3_Appendix E - Avifauna Impact Assessment.pdf](#)
16. [Hyperion PV3_Appendix F - Watercourse Impact Assessment.pdf](#)
17. [Hyperion PV3_Appendix G - Soils and Agricultural Potential.pdf](#)
18. [Hyperion PV3_Appendix H - Visual Impact Assessment.pdf](#)
19. [Hyperion PV3_Appendix I - Heritage and Palaeontological Impact Assessment.pdf](#)
20. [Hyperion PV3_Appendix J - Social Impact Assessment.pdf](#)
21. [Hyperion PV3_Appendix K - EAP Affirmation and Declaration.pdf](#)
22. [Hyperion PV3_Appendix L - Specialist Declarations.pdf](#)
23. [Hyperion PV3_Appendix M - A3 Maps.pdf](#)

[Back to Top](#)

Official Decisions & Comments

Date	Dec:Status
03/10/2018	Interim Comment

[Like 0](#) [G+](#)

[Tweet](#) [In](#) [+](#)

Hyperion Solar Development 2

Hyperion Solar Development 2.

Project Name: Hyperion Solar Development 2

Applicant: Cyraguard (Pty) Ltd

Proposed Activity: The construction of a photovoltaic (PV) solar energy facility (SEF) with a contracted capacity of up to 75MW. The development footprint will be ~180ha and will include the following infrastructure:

- Arrays of PV panels with a capacity of up to 75MW.
- Mounting structures to support the PV panels.

+27 (0) 11 656 3237 info@savannahsa.com



Downloads

HYPERION SOLAR DEVELOPMENT 2

SCOPING REPORT

APPENDIX A - EIA PROJECT CONSULTING TEAM AND SPECIALIST CVS

APPENDIX B - CORRESPONDENCE WITH AUTHORITIES

APPENDIX C1 - I&AP DATABASE

<http://www.savannahsa.com/public-documents/energy-generation/hyperion-solar-development-2/downloads-hyperion-solar-development-2/>

TITLE	NAME	SURNAME	POSITION	DELIVERY ADDRESS	CONTACT DETAILS	REPORT FORMAT & METHOD OF DISTRIBUTION	COMMENTS (Follow-ups & confirmation of receipt)				
							1ST REMINDER 16-11-2018	ADDITIONAL	2ND REMINDER 23-11-2018	FINAL REMINDER 26-11-2018	COMMENTS RECEIVED
DEPARTMENT OF AGRICULTURE, FORESTRY AND FISHERIES											
<i>National</i>											
Mr	Thoko	Buthelezi	Administration Clerk	Office 270 Delpen Building C/o Annie Botha & Union Streets PRETORIA 0002	Tel.: 012 319 7634 E-mail: thokob@daff.gov.za	1 x CD Courier Waybill No.:1298110553	Email	Email: 21-11-2018	Email	Email	No Comments
<i>Northern Cape Province</i>											
Ms	Jacoline	Mans	Chief Forester: NFA Regulations	Louisvale Road UPINGTON 8801	Tel.: 054 338 5909 E-mail: jacolinema@daff.gov.za	1 x CD Courier Waybill No: 1298110542	Email	Email: 21-11-2018	Email	Email	Comments Received
DEPARTMENT OF ENERGY											
Mr	Pheladi	Masipa	Acting Project manager: Renewable Energy Initiatives	192 Visagie Street Pretoria 0002	Tel: 0124067650 E-mail: Pheladi.Masipa@energy.gov.za	x1 CD Courier Waybill No.: 1298110520	Email	Email: 21-11-2018	Email	Email	No Comments
SOUTH AFRICAN DEFENCE FORCE											
Lt Col	Keasenosi	Zondi	SO1 Military Integrated Environment Management	Armscor Building Block 5, Level 4 Cnr Delmas Avenue & Nossolo Streets Erasmuskloof Pretoria 0001	Cell: 072 860 5478 E-mail: kebasenosi@yahoo.com	x1 CD Courier Waybill No.: 1298110623	Email	Email: 21-11-2018	Email	Email	No Comments
DEPARTMENT OF ENVIRONMENTAL AND NATURE CONSERVATION: NORTHERN CAPE											
Ms	Samantha	De la Fontaine	Production Scientist Grade A District Ecologist	1st Floor Provincial Building Cnr Rivier & nelson mandele Roads Upington 8800	Cell: 072 860 5478 E-mail: sdelafontaine@gmail.com	x1 CD Courier Waybill No.: 1298110671	Email	Email: 21-11-2018	Email	Email	No Comments
DEPARTMENT OF ENVIRONMENTAL AFFAIRS											
			Registry - EIA Administration	Environmental House 473 Steve Biko Road PRETORIA 0002		2 x Hard Copies of Hyperion 1, 2, 3 and 4 (X2Copies for each) 4 x USBs (1 USB for each) By Hand: MEMO					Comments Received Hyperion 1, 2 & 3 Hyperion 4 will be submitted in Impact Phase (as per e-mail confirmation)
<i>Biodiversity Department</i>											
Ms	Wilma	Lutsch	Director: Biodiversity Conservation	Environmental House 473 Steve Biko Road PRETORIA 0002	Tel.: 012 399 9000 E-mail: wlutsch@environment.gov.za	1 x CD BY HAND (Upon delivery, Savannah was informed that Ms Lutsch retired and Reports to be delivered to Mr Tshitwamulomoni)	E-mail	E-mail: 21-11-2018	E-mail	Email	No Comments
Mr	Stanley	Tshitwamulomoni			E-mail: stanleyt@environment.gov.za						
DEPARTMENT OF MINERAL RESOURCES (DMR)											
<i>Northern Cape Province</i>											
Mr	Kevin	Mutheiwana	Regional Manager	Hopley Centre C/o Van der Stel & Van Riebeeck Streets SPRINGBOK 8240	Tel.: 053 807 1707 E-mail: Mmboneni.Mutheiwana@dmr.gov.za	1 x CD Courier Waybill No.:1298110601	Email	Email: 21-11-2018	Email	Email	Comments Received
DEPARTMENT OF ROADS AND PUBLIC WORKS											
<i>Northern Cape Province</i>											
Ms	Jaco	Roelofse	Director: Roads	45 Schmidtsdrift Road KIMBERLEY 8301	Tel.: 05 839 2100 Cell: 076 811 6206 E-mail: roelofse.j@vodamail.co.za	1x CD Courier Waybill No.: 1298110586	Email	Email: 21-11-2018	Email	Email	No Comments
DEPARTMENT OF WATER AND SANITATION											

						REPORT FORMAT & METHOD OF	COMMENTS (Follow-ups & confirmation of receipt)				
National											
Mr	Steven	Shibambu	Manager: Water Quality Management Lower Orange Water Management Area	Louisvale Road UPINGTON 8801	Tel.: 054 338 5800 E-mail: shibampus@dwa.gov.za	LPN: as per Nicolene not to be delivered, Abe Abrahams to get the CD and HC	Email		Email	Email	Comments Received
Northern Cape Province											
Mr	Abe	Abrahams	Chief Director	28 Central Road Beraconsfield KIMBERLEY 8301	Ms Lindiwe Franks Tel.: 053 830 8800 Cell: 082 883 6741 E-mail: fransl@dwa.gov.za	1 x Printed Copy 4 x CD (x1 for each project) 1x HC of each project Courier Waybill No.:1298110704	Email	Email: 21-11-2018	Email	Email	Comments Received
NORTHERN CAPE DEPARTMENT OF ENVIRONMENT AND NATURE CONSERVATION											
Mr	Bryan	Fisher	Director: Environmental Quality Management	Sasko Building 90 Long Street KIMBELEY 8301	Tel.: 083 807 7431 Cell: 083 270 8323 E-mail: bfisher@ncpg.gov.za	4 x CD(x1 for each project) 1x HC of each project Courier Waybill No.:1298110693	Email	Email: 21-11-2018	Email	Email	No Comments
DEPARTMENT OF RURAL DEVELOPMENT AND LAND REFORM											
Mr	Nozizwe	Makgalemele	Deputy Director General: Spatial Land - Use and Management	Old Building 184 Jacob Mare Street Pretoria 0001	Tel.: 0123128006 E-mail: Nozizwe.Makgalemele@drdlr.gov.za	1 x CD Courier Waybill No.:1298110612	Email	Email: 21-11-2018	Email	Email	No Comments
JOHN TAOLO GAETSEWE DISTRICT MUNICIPALITY											
Mr	Disang	Molaole	Municipal Manager	4 Federale Mynbou Street Kuruman 8460	Tel.: 0537128700 E-mail: dmolaole@taologaetsewe.gov.za	1 x CD Courier Waybill No.:1298110634	Email	Email: 21-11-2018	Email	Email	No Comments
GAMAGARA LOCAL MUNICIPALITY											
Mr	Thusoeng	Itumeleng	Municipal Manager	Civic Centre Cnt Hendrick van Eck & frikkie Meyer Road Kathu 8446	Tel.: 0537236000 E-mail: clementi@gamagara.gov.za	1 x CD Courier Waybill No.:1298110645	Email	Email: 21-11-2018	Email	Email	No Comments
NATIONAL ENERGY REGULATOR OF SOUTH AFRICA (NERSA)											
Mr	Tamai	Hore	Senior Engineer: Generation Licensing	Kulawula House 526 Madiba Street ARCADIA 0083	Tel.: 012 401 4053 E-mail: tamai.hore@nersa.org.za	1 x CD Courier Waybill No.:1298110564	Email	Email: 21-11-2018	Email	Email	No Comments
Mr	Ratha Andrew	Timothy	Senior Engineer: Generation Licensing	Kulawula House 526 Madiba Street ARCADIA 0083	Tel.: 012 401 4053 E-mail: ratha.timothy@gmail.com	1 x CD Courier Waybill No.:1298110564	Email	Email: 21-11-2018	Email	Email	No Comments
SOUTH AFRICA HERITAGE RESOURCES AGENCY (SAHRA)											
UPLOAD ONTO SAHRIS Hyperion 1 Case ID: 12965 Hyperion 2 Case ID: 12966 Hyperion 3 Case ID: 12967 Hyperion 4 Case ID: 12968											Comments Received

savannah environmental		ENVIRONMENTAL IMPACT ASSESSMENT AND PUBLIC PARTICIPATION PROCESS FOR THE HYPERION SOLAR DEVELOPMENT 1,2,3 & 4 AND ASSOCIATED INFRASTRUCTURE, NORTHERN CAPE PROVINCE									
DISTRIBUTION OF THE SCOPING REPORT FOR REVIEW TO KEY STAKEHOLDERS FOR COMMENT: Review Period Friday, 26 October 2018 to Monday, 26 November 2018											
TITLE	NAME	SURNAME	POSITION	DELIVERY ADDRESS	CONTACT DETAILS	REPORT FORMAT & METHOD OF DISTRIBUTION	COMMENTS (Follow-ups & confirmation of receipt)				
							1ST REMINDER 16-11-2018	ADDITIONAL	2ND REMINDER 23-11-2018	FINAL REMINDER 26-11-2018	COMMENTS RECEIVED
Northern Cape Province											
<i>Province</i>											
Mr	Nicol	Jansen	President: Agri North West	No 2 Bebington Street Monument Heights KIMBERLEY 8301	Tel.: 053 82 9595 E-mail: henning@agrink.co.za	1xCD Courier Waybill No.:1298110575	Email	Email: 21-11-2018	Email	Email	No Comments
AIR TRAFFIC AND NAVIGATION SERVICES											
Mr	Simphiwe	Masilela	Obstacle Evaluator	Eastgate Office Park Block C South Boulevard Road BRUMA 2198	Tel.: 011 607 1228 E-mail: simphiwem@atns.co.za	1 x CD Courier Waybill No.:12988110590	Email	Email: 21-11-2018	Email	Email	Comments Received
ESKOM HOLDINGS SOCLTD											
<i>Head Office</i>											
Mr	John	Geeringh	Senior Environmental Advisor	COLLECT AT SAVANNAH ENVIRONMENTAL OFFICES	Tel.: 011 516 7233 Cell: 083 632 7663 E-mail: john.geeringh@eskom.co.za	1 x CD (will pick up himself)	Email	Email: 21-11-2018	Email	Email	Comments Received
Northern Cape Province											
Ms	Andrea	Van Gensen	Regional Environmental Manager	120 Henry Street BLOEMFONTEIN 9301	Tel.: 083 830 5775 Cell: 082 482 7579 E-mail: vangensen@eskom.co.za	1 x CD Courier Waybill No.:1298110660	Email		Email	Email	No Comments
SOUTH AFRICAN NATIONAL ROADS AGENCY LTD (SANRAL)											
Ms	Nicole	Abrahams	Environmental Coordinator: Western Region	1 Havenga Street Oakdale BELLEVILLE 7530	Tel.: 021 857 4602 E-mail: abrahams@nra.co.za	4 x CD (x1 for each project) 1x HC of each project Courier Waybill No.:1298110682	Email	Email: 21-11-2018	Email	Email	No Comments
SOUTH AFRICAN RADIO ASTRONOMY OBSERVATORY (SKA amalgamated)											
Dr	Adriaan	Tiplady	Manager: Site Categorisation	1st Floor 17 Baker Street ROSEBANK 2196	Tel.: 011 442 2434 Cell: 072 372 0134 E-mail: atiplady@ska.ac.za	1 x CD Courier Waybill No.:1298111065	E-mail	E-mail: 21-11-2018	E-mail	Email	No Comments
Mr	Busang	Sethole	Analyst: Spectrum and Telecoms		Tel.: 011 268 3449 E-mail: bsethole@ska.ac.za	(SKA SA merged with Marteebeeshoek Radio Astronomy Observatory (HartRAO) to form SARAO)					

26 October 2018

Attention: Chief Director: Integrated Environmental Authorisations
Department of Environmental Affairs
Cnr Steve Biko and Soutpansberg Road
Pretoria
0001

**ENVIRONMENTAL IMPACT ASSESSMENT AND
PUBLIC PARTICIPATION PROCESS**

HYPERION SOLAR DEVELOPMENT 2, NORTHERN CAPE PROVINCE

SCOPING REPORT FOR PUBLIC REVIEW

Savannah Environmental has been appointed to undertake the Environmental Impact Assessment process for the Hyperion Solar Development 2 situated on a site approximately 16km north of the town of Kathu, Northern Cape Province.

Please find herewith attached the Scoping Report (2 hard copies and 1 USB) for public review and a new application form. The electronic copy of the application for Environmental Authorisation is included on the USB. The 30-day review period for the report is from **26 October 2018 – 26 November 2018.** Please submit your written comments by **26 November 2018.**

Please contact me with any queries in this regard, and advise should the Department require any additional information pertaining to this project.

Kind regards

THALITA BOTHA
SAVANNAH ENVIRONMENTAL
(thalita@savannahsa.com)

MEMO

DATE:	26 October 2018
TO:	Department of Environmental Affairs
ATT:	Chief Director: Integrated Environmental Authorisations
REFERENCE:	N/A
OUR REFERENCE:	SE2167

Please find attached x2 Hard Copies and x1 Protected USB of the Scoping Report for public review and a new application form for Hyperion Solar Development 2, Northern Cape Province.

NAME OF RECIPIENT:

SIGNATURE:

DATE RECEIVED:

STAMP:

J. Jodas *S. Matsabu*

ENVIRONMENTAL AFFAIRS INT ENV AUTH
2018 -10- 26
SIGN: <i>[Signature]</i>



environmental affairs

Department:
Environmental Affairs
REPUBLIC OF SOUTH AFRICA

Private Bag X 447 · PRETORIA · 0001 · Environment House · 473 Steve Biko Road, Arcadia · PRETORIA

DEA Reference: 14/12/16/3/3/2/1110

Enquiries: Azrah Essop

Tel: 012 399 8529 E-mail: AEssop@environment.gov.za

Jo-Anne Thomas
Savannah Environmental (Pty) Ltd
P O Box 148
SUNNINGHILL
2157

Tel: 011 656 3237
Email: joanne@savannahsa.com

PER EMAIL / MAIL

Dear Sir/Madam

ACKNOWLEDGEMENT OF RECEIPT OF THE NEW APPLICATION FOR ENVIRONMENTAL AUTHORISATION (ENVIRONMENTAL IMPACT ASSESSMENT PROCESS) AND SCOPING REPORT FOR THE PHOTOVOLTAIC SOLAR ENERGY FACILITY FOR THE PROPOSED HYPERION SOLAR DEVELOPMENT 2, NORTHERN CAPE PROVINCE

The Department confirms having received the Application and draft Scoping Report for Environmental Authorisation for the abovementioned project on 26 October 2018. We further confirm that you have submitted these documents to comply with the National Environmental Management Act, 1998 (Act No. 107 of 1998) Environmental Impact Assessment Regulations, 2014 published under Government Notice R982 in Government Gazette No. 38282 dated 04 December 2014, as amended ('the EIA Regulations, 2014').

Please take note of Regulation 40(3) of the EIA Regulations, 2014 which states that potential interested & Affected Parties, including the Competent Authority, may be provided with an opportunity to comment on reports and plans contemplated in Regulation 40(1) of the EIA Regulations, 2014, prior to the submission of an application but must be provided an opportunity to comment on such reports once an application has been submitted to the Competent Authority.

Note that in terms of Regulation 45 of the EIA Regulations, 2014 this application will lapse if the applicant fails to meet any of the time-frames prescribed in terms of these Regulations, unless an extension has been granted by the Department in terms of Regulation 3(7) of the EIA Regulations, 2014.

All documentation delivered to the physical address contained in this form must be delivered during the official Departmental Office Hours which is visible on the Departmental gate. EIA related documents (includes application forms, reports or any EIA related submissions) that are faxed; emailed; delivered to Security or placed in the Departmental Tender Box will not be accepted.

You are hereby reminded of Section 24F of the National Environmental Management Act, 1998 (Act No. 107 of 1998), as amended, that no activity may commence prior to an Environmental Authorisation being granted by the Department.

Kindly quote the abovementioned reference number in any future correspondence in respect of the application.

Yours sincerely



Mr Sabelo Malaza

Chief Director: Integrated Environmental Authorisations

Department of Environmental Affairs

Letter signed by: Ms Azrah Essop

Designation: Environmental Officer: EIA Coordination, Strategic Planning and Support

Date: 30 October 2018

CC:	Matteo Brambilla	Cyraguard (Pty) Ltd	Email: d.pasi@buildingenergy.it
	Bryan Fisher	Northern Cape Department of Environment and Nature Conservation	Email: BFisher@ncpg.gov.za
	Thusong Itumeleng	Gamagara Local Municipality	Email: clementi@gamagara.gov.za

25 October 2018

Mr Nicol Jansen
President: Agri Northern Cape
No 2 Bebington Street
Monument Heights
KIMBERLEY 8301

Per Courier

Dear Mr Jansen,

**ENVIRONMENTAL IMPACT ASSESSMENT AND PUBLIC PARTICIPATION PROCESSES FOR THE PROPOSED
HYPERION SOLAR DEVELOPMENT 1, 2, 3 and 4 AND ASSOCIATED INFRASTRUCTURES NEAR KATHU,
NORTHERN CAPE PROVINCE**

NOTICE OF AVAILABILITY OF THE SCOPING REPORTS FOR REVIEW AND WRITTEN COMMENTS

The development of four (4) separate photovoltaic (PV) solar energy facilities (SEFs) as well as associated infrastructure are being proposed on the Remaining Extent of the Farm Lyndoch 432 situated ~16km north of Kathu in the Northern Cape Province. The proposed SEFs fall within the jurisdiction of the Gamagara Local Municipality and within the greater John Taolo Gaetsewe District Municipality.

Each of the four (4) SEFs will be constructed as separate stand-alone projects, with a separate project development company (or Special Purpose Vehicle) as the applicant for each project. The projects are:

Project Name:	Applicant:
Hyperion Solar Development 1	Hyperion Solar Development 1 (Pty) Ltd
Hyperion Solar Development 2	Cyraguard (Pty) Ltd
Hyperion Solar Development 3	Nomispank (Pty) Ltd
Hyperion Solar Development 4	Nomispan (Pty) Ltd

This letter serves to inform you that the Scoping Reports (SRs) are available for your Organisation's review and written comments, and a CD containing the SRs is included in this envelope.

Please note that the SRs' review period is from **Friday, 26 October 2018** to **Monday, 26 November 2018** and we are looking forward receiving your Organisation's written comment on the SRs before or on the closing date of the review period.

Kind regards



Nicolene Venter

**Public Participation and Social Consultant
Savannah Environmental**



0861 223 224

www.dawnwing.co.za

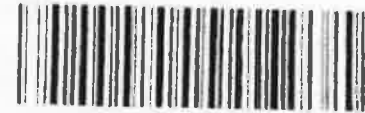

1298110575

a division of DPD LASER

WAYBILL

Sender to complete yellow areas only

FROM: SAVANNAH ENVIRO S A		Contents: CD		HAZARDOUS YES NO		Filing Ref: 9167	
Address: 1ST FLOOR, BLOCK 2 5 WOODLANDS DRIVE WOODMEAD		No. of Parcels: 1		Parcel Weight: 0,05kg		PARCEL DETAILS	
City/Country: WOODMEAD		Postal Code: 2128		Dimensions (cm): 40 30 1		SERVICE (mark only one)	
Senders Name: LISA		Phone: 011 6563237		Special Instructions: (1)		<input checked="" type="checkbox"/> Economy Cargo <input type="checkbox"/> Domestic Road Freight <input type="checkbox"/> Collectors Express <input type="checkbox"/> International Documents <input type="checkbox"/> International Non Documents <input type="checkbox"/> International Air Freight <input type="checkbox"/> International Road Freight	
TO: President! Agri Northern Cape		Street Address (P.O. Box Addresses not accepted): P.O. No 2 Bebington Street Monument Heights.		City/Country: Kimberley		Postal Code: 8301	
Receiver's Name: MY Nicol Jensen		Phone: 053-832-7126		Dawn Wing reserves the right to mark the service "Overnight Express" should no service level be selected		SPECIAL INSTRUCTIONS	
By signing this waybill the sender is concluding a contract with Dawn Wing and warrants his authority to enter into this contract and to bind the entity, which therein represents. The terms and conditions of this contract are contained on the reverse of the sender's copy.		Date: 25-10-18		Collected By Courier: [Signature]		<input type="checkbox"/> Tick to select limited liability option (to a maximum amount of R50 000) for non-excluded articles Customs Value ZAR: [] Value of Article ZAR: [] Account to be Debited: JB6925 Sender's Ref / Bag No.: []	
Senders Name: [Signature]		Date: 25-10-18		Time: [Signature]		RECEIVED IN GOOD ORDER AND CONDITION Receiver's Signature: [Signature] Print Name: [Signature] Date: 24/10/18 Time: 08:15	
Special Instructions: []		CASH AMOUNT R []		PAID YES NO		PROOF OF DELIVERY 	

DAWN WING

A Division of DPD Laser Express Logistics (Pty) Ltd
 Reg. No. 2005/033353/07 VAT No. 4690215280
 FSP NO 32909

*All weight and dimensions subject to verification through electronic weight and dimension machine (SABS calibrated)

PROOF OF DELIVERY

25 October 2018

Mr Simphiwe Masilela
Obstacle Evaluator
Eastgate Office Park
Block C
South Boulevard Road
BRUMA 2198

Per Courier

Dear Mr Masilela,

**ENVIRONMENTAL IMPACT ASSESSMENT AND PUBLIC PARTICIPATION PROCESSES FOR THE PROPOSED
HYPERION SOLAR DEVELOPMENT 1, 2, 3 and 4 AND ASSOCIATED INFRASTRUCTURES NEAR KATHU,
NORTHERN CAPE PROVINCE**

NOTICE OF AVAILABILITY OF THE SCOPING REPORTS FOR REVIEW AND WRITTEN COMMENTS

The development of four (4) separate photovoltaic (PV) solar energy facilities (SEFs) as well as associated infrastructure are being proposed on the Remaining Extent of the Farm Lyndoch 432 situated ~16km north of Kathu in the Northern Cape Province. The proposed SEFs fall within the jurisdiction of the Gamagara Local Municipality and within the greater John Taolo Gaetsewe District Municipality.

Each of the four (4) SEFs will be constructed as separate stand-alone projects, with a separate project development company (or Special Purpose Vehicle) as the applicant for each project. The projects are:

Project Name:	Applicant:
Hyperion Solar Development 1	Hyperion Solar Development 1 (Pty) Ltd
Hyperion Solar Development 2	Cyraguard (Pty) Ltd
Hyperion Solar Development 3	Nomispank (Pty) Ltd
Hyperion Solar Development 4	Nomispan (Pty) Ltd

This letter serves to inform you that the Scoping Reports (SRs) are available for your Company's review and written comments, and a CD containing the SRs is included in this envelope.

Please note that the SRs' review period is from **Friday, 26 October 2018** to **Monday, 26 November 2018** and we are looking forward receiving your Company's written comment on the SRs before or on the closing date of the review period.

Kind regards



Nicolene Venter
Public Participation and Social Consultant
Savannah Environmental



a division of dpd LASER

0861 223 224
www.dawnwing.co.za



1298110752

WAYBILL

Sender to complete yellow areas only

FROM: SAVANNAH ENVIRO S A		Contents: CD		HAZARDOUS YES NO <small>IF YES, SEE REVERSE</small>		Filing Ref: 2167	
Address: 1ST FLOOR. BLOCK 2 5 WOODLANDS DRIVE WOODMEAD		No. of Parcels: ①		Vol(kg)-T's & C's Apply: ①		Mass(kg)-T's & C's Apply: 0.056	
City/Country: WOODMEAD		Postal Code: 2128		Dimensions (cm): 40 30 1 ①		SERVICE (mark only one) <input checked="" type="checkbox"/> Overnight Express <input type="checkbox"/> Economy Cargo <input type="checkbox"/> Domestic Road Freight <input type="checkbox"/> Sameday Express <input type="checkbox"/> International Documents <input type="checkbox"/> International Non Documents <input type="checkbox"/> International Air Freight <input type="checkbox"/> International Road Freight	
Senders Name: LISA		Tel: 011 6563237		SPECIAL INSTRUCTIONS <input type="checkbox"/> Saturday Delivery Collection <input type="checkbox"/> Dawn Delivery 9H00 / Time Required <input type="checkbox"/> After Hours <input type="checkbox"/> Sunday / Public Holiday <input type="checkbox"/> Confirmation of Delivery <input type="checkbox"/> Tick to select limited liability option (to a maximum amount of R50 000) for non-excluded articles			
TO: AN Traffic and Navigation Services		Street Address (P.O. Box Addresses not accepted): Eastgate Office park Block C South Boulevard Road		Dawn Wing reserves the right to mark the service "Overnight Express" should no service level be selected		Customs Value ZAR: _____ Value of Article ZAR: _____ Account to be Debited: JB6925 Sender's Ref. / Bag No.: _____	
City/Country: Bruma		Postal Code: 2198		RECEIVED IN GOOD ORDER AND CONDITION Receivers Signature: Print Name: Noks Date: 21/10/18 Time: 3hrs			
Receiver's Name: Simphiwe Masilela		Tel: 011-607-1228		Terms strictly 30 days from date of statement		CASH AMOUNT R: _____ PAID YES NO Special Instructions: _____	
Senders Name: Georgeing		Date: 25-10-18		Collected By Courier:		Date: 21/10/18	
Signature:		Time: _____		Signature:		Time: _____	

DAWN WING
A Division of DPD Laser Express Logistics (Pty) Ltd
Reg. No. 2006/033353/07 VAT No. 4690235280
FSP NO 32009

*All weight and dimensions subject to verification through electronic weight and dimension machine (SABS calibrated)

PROOF OF DELIVERY

25 October 2018

Ms Jacqueline Mans
Chief Forester: NFA Regulations
Department of Agriculture, Forestry and Fisheries
Louisvale Road
UPINGTON 8801

Per Courier

Dear Ms Mans,

**ENVIRONMENTAL IMPACT ASSESSMENT AND PUBLIC PARTICIPATION PROCESSES FOR THE PROPOSED
HYPERION SOLAR DEVELOPMENT 1, 2, 3 and 4 AND ASSOCIATED INFRASTRUCTURES NEAR KATHU,
NORTHERN CAPE PROVINCE**

NOTICE OF AVAILABILITY OF THE SCOPING REPORTS FOR REVIEW AND WRITTEN COMMENTS

The development of four (4) separate photovoltaic (PV) solar energy facilities (SEFs) as well as associated infrastructure are being proposed on the Remaining Extent of the Farm Lyndoch 432 situated ~16km north of Kathu in the Northern Cape Province. The proposed SEFs fall within the jurisdiction of the Gamagara Local Municipality and within the greater John Taolo Gaetsewe District Municipality.

Each of the four (4) SEFs will be constructed as separate stand-alone projects, with a separate project development company (or Special Purpose Vehicle) as the applicant for each project. The projects are:

Project Name:	Applicant:
Hyperion Solar Development 1	Hyperion Solar Development 1 (Pty) Ltd
Hyperion Solar Development 2	Cyraguard (Pty) Ltd
Hyperion Solar Development 3	Nomispan (Pty) Ltd
Hyperion Solar Development 4	Nomispan (Pty) Ltd

This letter serves to inform you that the Scoping Reports (SRs) are available for your Department's review and written comments, and a CD containing the SRs is included in this envelope.

Please note that the SRs' review period is from **Friday, 26 October 2018** to **Monday, 26 November 2018** and we are looking forward receiving your Department's written comment on the SRs before or on the closing date of the review period.

Kind regards



Nicolene Venter
Public Participation and Social Consultant
Savannah Environmental



0861 223 224

www.dawnwing.co.za



1298110730

A Division of dpd Laser

WAYBILL

Sender to complete yellow areas only

FROM: SAVANNAH ENVIRO S A		Contents: <i>CD</i>		HAZARDOUS YES NO		Filing Ref: <i>2167</i>	
Address: 1ST FLOOR, BLOCK 2 5 WOODLANDS DRIVE WOODMEAD		Parcel Details: No. of Parcels: <i>1</i> Dimensions (cm): <i>10 30 1</i>		Service (mark only one): <input checked="" type="checkbox"/> Priority <input type="checkbox"/> Economy <input type="checkbox"/> Standard <input type="checkbox"/> Parcel Post		SPECIAL INSTRUCTIONS: Return to sender if undeliverable <input type="checkbox"/> Customs Value: <i>0.00</i> Account to be Debited: <i>JB6925</i>	
City/Country: WOODMEAD		Postal Code must be used in: 2128		Dawn Wing reserves the right to mark the service "Overnight Express" should no service level be selected		RECEIVED IN GOOD ORDER AND CONDITION	
Sender's Name: LISA		Phone No: 011 6563237		Terms strictly 30 days from date of statement		Receiver's Signature: <i>[Signature]</i>	
TO: Department of Agriculture, Forestry and Fisheries. Louisvale Road.		City/Country: Upington		CASH AMOUNT: R <input type="text"/>		Print Name: P. Scheffers	
Receiver's Name: Jacoline Mans		Postal Code must be used in: 8801		PAID YES NO		Date: <i>29/10/18</i> Time: <i>13:08</i>	
Street Address (P.O. Box Addresses not accepted): Louisvale Road.		Receiver's Phone No: 082 808 2737		Special Instructions:		PROOF OF DELIVERY <input type="checkbox"/>	
Sender's Name: <i>[Signature]</i>		Date/Time: <i>25-10-18</i>		Collected By Counter: <i>[Signature]</i>		DPD NO 32009	

DAWN WING

A Division of DPD Laser Express Logistics (Pty) Ltd
Reg. No. 2006/031353/07 VAT No. 4990235280
FSP NO 32009

*All weight and dimensions subject to verification through electronic weight and dimension machine (SABS calibrated)

11/20/2016 15:42:22:00 FAX AFRIKA (Pty) Ltd Tel: 011 51025100

25 October 2018

Ms Thoko Buthelezi
Administration Clerk
AgriLand Liaison Office
Department of Agriculture, Forestry and Fisheries
Office 270, Delpen Building
Cnr Annie Botha & Union Street
RIVIERA 0084

Per Courier

Dear Ms Buthelezi,

**ENVIRONMENTAL IMPACT ASSESSMENT AND PUBLIC PARTICIPATION PROCESSES FOR THE PROPOSED
HYPERION SOLAR DEVELOPMENT 1, 2, 3 and 4 AND ASSOCIATED INFRASTRUCTURES NEAR KATHU,
NORTHERN CAPE PROVINCE**

NOTICE OF AVAILABILITY OF THE SCOPING REPORTS FOR REVIEW AND WRITTEN COMMENTS

The development of four (4) separate photovoltaic (PV) solar energy facilities (SEFs) as well as associated infrastructure are being proposed on the Remaining Extent of the Farm Lyndoch 432 situated ~16km north of Kathu in the Northern Cape Province. The proposed SEFs fall within the jurisdiction of the Gamagara Local Municipality and within the greater John Taolo Gaetsewe District Municipality.

Each of the four (4) SEFs will be constructed as separate stand-alone projects, with a separate project development company (or Special Purpose Vehicle) as the applicant for each project. The projects are:

Project Name:	Applicant:
Hyperion Solar Development 1	Hyperion Solar Development 1 (Pty) Ltd
Hyperion Solar Development 2	Cyraguard (Pty) Ltd
Hyperion Solar Development 3	Nomispank (Pty) Ltd
Hyperion Solar Development 4	Nomispan (Pty) Ltd

This letter serves to inform you that the Scoping Reports (SRs) are available for your Department's review and written comments, and a CD containing the SRs is included in this envelope.

Please note that the SRs' review period is from **Friday, 26 October 2018** to **Monday, 26 November 2018** and we are looking forward receiving your Department's written comment on the SRs before or on the closing date of the review period.

Kind regards



Nicolene Venter
Public Participation and Social Consultant
Savannah Environmental



global express

a division of dpd LASER

0861 223 224

www.dawnwing.co.za



1298110553

WAYBILL

Sender to complete yellow areas only

FROM: SAVANNAH ENVIRO S A		Contents CD		HAZARDOUS YES NO		Filing Ref: 9167	
Address 1ST FLOOR. BLOCK 2 5 WOODLANDS DRIVE WOODMEAD		PARCEL DETAILS		SERVICE (mark only one)			
City/Country WOODMEAD		No. of Parcels 1		Vol(kg)-T's & C's Apply*		Mass(kg)-T's & C's Apply*	
Postal Code must be filled in 2128		Dimensions (cm) 40 30 1 @		<input checked="" type="checkbox"/> Overnight Express		<input type="checkbox"/> Economy Cargo	
Senders Name LISA		Postal Code must be filled in 011 6563237		<input type="checkbox"/> International Documents		<input type="checkbox"/> International Non Documents	
TO: Department of Agriculture, Forestry and Fisheries Office 270, Delpen Building Cnr Annie Rocha & Union Street		City/Country Riviera		Postal Code must be filled in 8084		SPECIAL INSTRUCTIONS	
Street Address (P.O. Box Addresses not accepted)		Dawn Wing reserves the right to mark the service "Overnight Express" should no service level be selected		<input type="checkbox"/> Saturday Delivery Collection		<input type="checkbox"/> Dawn Delivery 9:00 / Time Required	
Receiver's Name Thoko Buthelezi		Terms strictly 30 days from date of statement		<input type="checkbox"/> After Hours		<input type="checkbox"/> Sunday / Public Holiday	
By signing this waybill the sender is concluding a contract with Dawn Wing and warrants his authority to enter into this contract and to bind the entity, which he/she represents. The terms and conditions of this contract are contained on the reverse of the sender's copy.		CASH AMOUNT R		PAID YES NO		Tick to select limited liability option (to a maximum amount of R250,000) for non-regulated articles	
Senders Name Georgina		Date 25-10-16		Collected By Courier [Signature]		Date 25-10-16	
Signature [Signature]		Special Instructions		Customs Value ZAR		Value of Article ZAR	
Time		Time		Account to be Debited JB6925		Sender's Ref. / Bag No.	
Time		Time		RECEIVED IN GOOD ORDER AND CONDITION		Receivers Signature: [Signature]	
Time		Time		Print Name: [Signature]		Date: [Signature]	

DAWN WING

A Division of DPD Laser Express Logistics (Pty) Ltd
Reg. No. 2006/033353/07 VAT No. 4690235280
FSP NO 32009

*All weight and dimensions subject to verification through electronic weight and dimension machine (SABS calibrated)

PROOF OF DELIVERY



25 October 2018

Mr Pheladi Masipa
Acting Project Manager: Renewable energy Initiatives
Department of Energy
192 Visagie Street
PRETORIA 0002

Per Courier

Dear Mr Masipa,

**ENVIRONMENTAL IMPACT ASSESSMENT AND PUBLIC PARTICIPATION PROCESSES FOR THE PROPOSED
HYPERION SOLAR DEVELOPMENT 1, 2, 3 and 4 AND ASSOCIATED INFRASTRUCTURES NEAR KATHU,
NORTHERN CAPE PROVINCE**

NOTICE OF AVAILABILITY OF THE SCOPING REPORTS FOR REVIEW AND WRITTEN COMMENTS

The development of four (4) separate photovoltaic (PV) solar energy facilities (SEFs) as well as associated infrastructure are being proposed on the Remaining Extent of the Farm Lyndoch 432 situated ~16km north of Kathu in the Northern Cape Province. The proposed SEFs fall within the jurisdiction of the Gamagara Local Municipality and within the greater John Taolo Gaetsewe District Municipality.

Each of the four (4) SEFs will be constructed as separate stand-alone projects, with a separate project development company (or Special Purpose Vehicle) as the applicant for each project. The projects are:

Project Name:	Applicant:
Hyperion Solar Development 1	Hyperion Solar Development 1 (Pty) Ltd
Hyperion Solar Development 2	Cyraguard (Pty) Ltd
Hyperion Solar Development 3	Nomispan (Pty) Ltd
Hyperion Solar Development 4	Nomispan (Pty) Ltd

This letter serves to inform you that the Scoping Reports (SRs) are available for your Department's review and written comments, and a CD containing the SRs is included in this envelope.

Please note that the SRs' review period is from **Friday, 26 October 2018** to **Monday, 26 November 2018** and we are looking forward receiving your Department's written comment on the SRs before or on the closing date of the review period.

Kind regards



Nicolene Venter
Public Participation and Social Consultant
Savannah Environmental

Waybill Summary Details

Waybill Number :	1298110520	Waybill Date :	2018-10-26
Waybill Status :	POD RECEIVED	Service :	%%ServiceType%%
From :	JOHANNESBURG CENTRAL AREAS	To :	PRETORIA CENTRAL AREAS
Sender :	SAVANNAH ENVIRONMENT 5 WOODLANDS DRIVE OFFICE PARK CNR WOODLANDS DR & WESTERN SERVICE ROAD WOODMEAD EXT 2191	Receiver :	DEPARTMENT OF ENERGY 192 VISAGIE STREET PRETORIA 0002
Contact :	%%SenContact%%	Contact :	PHELADI MASIPA
Telephone :	%%SenTelNo%%	Telephone :	0124067660
Cellphone :	%%SenCelNo%%	Cellphone :	%%RecCelNo%%
Customer Ref :	%%InvoiceRefNo%%	Collection No :	
Total Parcels :	1	Total Mass :	0.10
Total Volume :	0.24	Value :	

Proof of Delivery

Received By	Date Received	Time	Parcels
Beryl Reception	2018-10-29	09:54	1

Detailed track and trace

Event	Location	Date	Time	Additional Information
SHIPMENT RECEIVED BY HUB	JNB	2018-10-26	21:39	
MASS DIMENSION VERIFICATION	JNB	2018-10-26	21:39	
SHIPMENT SHIPPED FROM DEPOT	JNB	2018-10-26	21:51	
PARCEL HAS LEFT DAWN WING	PRY	2018-10-29	07:25	
POD RECEIVED / DELIVERED	PRY	2018-10-29	10:07	

[Back](#)

25 October 2018

Ms Wilma Lutsch
Director: Biodiversity Conservation
Department of Environmental Affairs
Environmental House
473 Steve Biko Road
PRETORIA 0002

By Hand

Dear Ms Lutsch,

**ENVIRONMENTAL IMPACT ASSESSMENT AND PUBLIC PARTICIPATION PROCESSES FOR THE PROPOSED
HYPERION SOLAR DEVELOPMENT 1, 2, 3 and 4 AND ASSOCIATED INFRASTRUCTURES NEAR KATHU,
NORTHERN CAPE PROVINCE**

NOTICE OF AVAILABILITY OF THE SCOPING REPORTS FOR REVIEW AND WRITTEN COMMENTS

The development of four (4) separate photovoltaic (PV) solar energy facilities (SEFs) as well as associated infrastructure are being proposed on the Remaining Extent of the Farm Lyndoch 432 situated ~16km north of Kathu in the Northern Cape Province. The proposed SEFs fall within the jurisdiction of the Gamagara Local Municipality and within the greater John Taolo Gaetsewe District Municipality.

Each of the four (4) SEFs will be constructed as separate stand-alone projects, with a separate project development company (or Special Purpose Vehicle) as the applicant for each project. The projects are:

Project Name:	Applicant:
Hyperion Solar Development 1	Hyperion Solar Development 1 (Pty) Ltd
Hyperion Solar Development 2	Cyraguard (Pty) Ltd
Hyperion Solar Development 3	Nomispank (Pty) Ltd
Hyperion Solar Development 4	Nomispan (Pty) Ltd

This letter serves to inform you that the Scoping Reports (SRs) are available for your Organisation's view and written comments, and a CD containing the SRs is included in this envelope.

Please note that the SRs' review period is from **Friday, 26 October 2018** to **Monday, 26 November 2018** and we are looking forward receiving your Organisation's written comment on the SRs before or on the closing date of the review period.

Kind regards



Nicolene Venter

**Public Participation and Social Consultant
Savannah Environmental**

MEMO

DATE:	26 October 2018
TO:	Department of Environmental Affairs
ATT:	Wilma Lutch
REFERENCE:	N/A
OUR REFERENCE:	SE2167

Please find attached x1Protected CD of the Scoping Report for public review for Hyperion Solar Development 1, 2, 3 & 4, Northern Cape Province.

NAME OF RECIPIENT:

DEPT ENV AFFAIRS

SIGNATURE:

ENVIRONMENTAL AFFAIRS
INT ENV AUTH

DATE RECEIVED:

2018 -10- 26

STAMP:

SIGN: *M. Matsabu*

25 October 2018

Mr Kevin Mutheiwana
Regional Manager: Northern Cape Province
Department of Mineral Resources
Hopley Centre
Cnr Van der Stel & Van Riebeeck Street
SPRINGBOK 8240

Per Courier

Dear Mr Matheiwana,

**ENVIRONMENTAL IMPACT ASSESSMENT AND PUBLIC PARTICIPATION PROCESSES FOR THE PROPOSED
HYPERION SOLAR DEVELOPMENT 1, 2, 3 and 4 AND ASSOCIATED INFRASTRUCTURES NEAR KATHU,
NORTHERN CAPE PROVINCE**

NOTICE OF AVAILABILITY OF THE SCOPING REPORTS FOR REVIEW AND WRITTEN COMMENTS

The development of four (4) separate photovoltaic (PV) solar energy facilities (SEFs) as well as associated infrastructure are being proposed on the Remaining Extent of the Farm Lyndoch 432 situated ~16km north of Kathu in the Northern Cape Province. The proposed SEFs fall within the jurisdiction of the Gamagara Local Municipality and within the greater John Taolo Gaetsewe District Municipality.

Each of the four (4) SEFs will be constructed as separate stand-alone projects, with a separate project development company (or Special Purpose Vehicle) as the applicant for each project. The projects are:

Project Name:	Applicant:
Hyperion Solar Development 1	Hyperion Solar Development 1 (Pty) Ltd
Hyperion Solar Development 2	Cyraguard (Pty) Ltd
Hyperion Solar Development 3	Nomispark (Pty) Ltd
Hyperion Solar Development 4	Nomispan (Pty) Ltd

This letter serves to inform you that the Scoping Reports (SRs) are available for your Department's review and written comments, and a CD containing the SRs is included in this envelope.

Please note that the SRs' review period is from **Friday, 26 October 2018** to **Monday, 26 November 2018** and we are looking forward receiving your Department's written comment on the SRs before or on the closing date of the review period.

Kind regards



Nicolene Venter

**Public Participation and Social Consultant
Savannah Environmental**

Waybill Summary Details

Waybill Number :	1298110601	Waybill Date :	2018-10-26
Waybill Status :	POD RECEIVED	Service :	%%ServiceType%%
From :	JOHANNESBURG CENTRALAREAS	To :	SOUTH AFRICA REMOTE T/SHIPS
Sender :	SAVANNAH ENVIRONMENT 5 WOODLANDS DRIVE OFFICE PARK CNR WOODLANDS DR & WESTERN SERVICE ROAD WOODMEAD EXT 2191	Receiver :	DEPARTMENT OF MINERAL RESOURCES CNR STEL & VAN RIEBEECK S TREET SPRINGBOK SPRINGBOK 8240
Contact :	%%SenContact%%	Contact :	KEVIN
Telephone :	%%SenTelNo%%	Telephone :	0538071707
Cellphone :	%%SenCelNo%%	Cellphone :	%%RecCelNo%%
Customer Ref :	%%InvoiceRefNo%%	Collection No :	
Total Parcels :	1	Total Mass :	0.10
Total Volume :	0.02	Value :	

Proof of Delivery

Received By	Date Received	Time	Parcels
ANN	2018-10-30	09:27	1

Detailed track and trace

Event	Location	Date	Time	Additional Information
SHIPMENT RECEIVED BY HUB	JNB	2018-10-26	21:39	
MASS DIMENSION VERIFICATION	JNB	2018-10-26	21:39	
SHIPMENT SHIPPED FROM DEPOT	JNB	2018-10-26	21:53	
SHIPMENT RECEIVED BY DEPOT	CPT	2018-10-28	22:24	
SHIPMENT SHIPPED FROM DEPOT	CPT	2018-10-29	07:12	
POD RECEIVED / DELIVERED	SBU	2018-10-30	09:55	

[Back](#)

25 October 2018

Dr Nozizwe Makgalemele
Deputy Director-General; Spatial Land-Use and Management
Department of Rural Development and Land Reform
Old Building
184 Jacob Mare Street
PRETORIA 0001

Per Courier

Dear Dr Makgalemele,

**ENVIRONMENTAL IMPACT ASSESSMENT AND PUBLIC PARTICIPATION PROCESSES FOR THE PROPOSED
HYPERION SOLAR DEVELOPMENT 1, 2, 3 and 4 AND ASSOCIATED INFRASTRUCTURES NEAR KATHU,
NORTHERN CAPE PROVINCE**

NOTICE OF AVAILABILITY OF THE SCOPING REPORTS FOR REVIEW AND WRITTEN COMMENTS

The development of four (4) separate photovoltaic (PV) solar energy facilities (SEFs) as well as associated infrastructure are being proposed on the Remaining Extent of the Farm Lyndoch 432 situated ~16km north of Kathu in the Northern Cape Province. The proposed SEFs fall within the jurisdiction of the Gamagara Local Municipality and within the greater John Taolo Gaetsewe District Municipality.

Each of the four (4) SEFs will be constructed as separate stand-alone projects, with a separate project development company (or Special Purpose Vehicle) as the applicant for each project. The projects are:

Project Name:	Applicant:
Hyperion Solar Development 1	Hyperion Solar Development 1 (Pty) Ltd
Hyperion Solar Development 2	Cyraguard (Pty) Ltd
Hyperion Solar Development 3	Nomispank (Pty) Ltd
Hyperion Solar Development 4	Nomispan (Pty) Ltd

This letter serves to inform you that the Scoping Reports (SRs) are available for your Department's review and written comments, and a CD containing the SRs is included in this envelope.

Please note that the SRs' review period is from **Friday, 26 October 2018** to **Monday, 26 November 2018** and we are looking forward receiving your Department's written comment on the SRs before or on the closing date of the review period.

Kind regards



Nicolene Venter
Public Participation and Social Consultant
Savannah Environmental

Waybill Summary Details

Waybill Number :	1298110612	Waybill Date :	2018-10-26
Waybill Status :	POD RECEIVED	Service :	%%ServiceType%%
From :	JOHANNESBURG CENTRAL AREAS	To :	PRETORIA CENTRAL AREAS
Sender :	SAVANNAH ENVIRONMENT 5 WOODLANDS DRIVE OFFICE PARK CNR WOODLANDS DR & WESTERN SERVICE ROAD WOODMEAD EXT 2191	Receiver :	DEPARTMENT OF RURAL DEVELOPMENT AND LAND RREFORM MENT AND LAND REFORM OLD BUILDING 184 JACOB MARE STREET PRETORIA CENTRAL 0001
Contact :	%%SenContact%%	Contact :	NOZIZWE MAKGALEMELE
Telephone :	%%SenTelNo%%	Telephone :	0123128006
Cellphone :	%%SenCelNo%%	Cellphone :	%%RecCelNo%%
Customer Ref :	%%InvoiceRefNo%%	Collection No :	
Total Parcels :	1	Total Mass :	0.10
Total Volume :	0.24	Value :	

Proof of Delivery

Received By	Date Received	Time	Parcels
Finalized : RTSBIL	2018-11-09	19:36	1

Detailed track and trace

Event	Location	Date	Time	Additional Information
SHIPMENT SHIPPED FROM DEPOT	JNB	2018-10-26	21:36	
SHIPMENT RECEIVED BY HUB	JNB	2018-10-26	21:39	
MASS DIMENSION VERIFICATION	JNB	2018-10-26	21:39	
PARCEL HAS LEFT DAWN WING	PRY	2018-10-29	07:25	
DAWN WING WILL CONTACT YOU	PRY	2018-10-29	09:46	
PARCEL HAS LEFT DAWN WING	PRY	2018-10-30	07:25	
DAWN WING WILL CONTACT YOU	PRY	2018-10-30	09:39	
SHIPMENT RECEIVED BY DEPOT	PRY	2018-11-09	04:12	
POD RECEIVED / DELIVERED	PRY	2018-11-09	19:38	

[Back](#)

25 October 2018

Mr Abe Abrahams
Chief Director
Department of Water and Sanitation
28 Central Road
Beaconsfield
KIMBERLEY 8301

Per Courier

Dear Mr Abrahams,

**ENVIRONMENTAL IMPACT ASSESSMENT AND PUBLIC PARTICIPATION PROCESSES FOR THE PROPOSED
HYPERION SOLAR DEVELOPMENT 1 AND ASSOCIATED INFRASTRUCTURES NEAR KATHU, NORTHERN
CAPE PROVINCE**

NOTICE OF AVAILABILITY OF THE SCOPING REPORT FOR REVIEW AND WRITTEN COMMENTS

Hyperion Solar Development 1 (Pty) Ltd, the developer, is proposing the development of the Hyperion Solar Photovoltaic (PV) 1 solar energy facility and associated infrastructure on the Remaining Extent of the Farm Lyndoch 432 situated ~16km north of Kathu in the Northern Cape Province. The proposed development falls within the jurisdiction of the Gamagara Local Municipality and within the greater John Taolo Gaetsewe District Municipality.

This letter serves to inform you that the Scoping Report (SR) is available for your Department's review and written comments, and a hard copy and CD containing the SR is included in this envelope.

Please note that the SR's review period is from **Friday, 26 October 2018** to **Monday, 26 November 2018** and we are looking forward receiving your Department's written comment on the SR before or on the closing date of the review period.

Kind regards



Nicolene Venter

**Public Participation and Social Consultant
Savannah Environmental**



a division of dpd LASER

0861 223 224
www.dawnwing.co.za

WAYBILL



1298110704

Sender to complete yellow areas only

FROM: SAVANNAH ENVIRO S A		Contents: CH+HC		HAZARDOUS YES NO		Filing Ref: 2167	
Address: 1ST FLOOR, BLOCK 2 5 WOODLANDS DRIVE WOODMEAD		No. of Parcels: ①		Dimensions (cm): 40 30 7 ①		PARCEL DETAILS	
City/Country: WOODMEAD		Postal Code: 2128		Messages: 7/90/15		SERVICE (mark only one)	
Senders Name: LISA		Phone: 011 6563237		International Documents: <input checked="" type="checkbox"/>		Economy Cargo: <input type="checkbox"/>	
TO: Department of water and Sanitation: 28 Central Road Beaconsfield		City/Country: Kimberley		Postal Code: 8301		International Air Freight: <input type="checkbox"/>	
Receiver's Name: Mr. Abe Abrahams		Phone: 082-583-6741		Special Instructions: Dawn Wing reserves the right to mark the service "Overnight Express" should no service level be selected		SPECIAL INSTRUCTIONS	
Senders Name: Georgeina		Date: 25-10-18		Collected By Courier: [Signature]		Saturday Delivery: <input type="checkbox"/>	
Signature: [Signature]		Time: [Time]		Time: [Time]		Sunday Public Holiday: <input type="checkbox"/>	
Special Instructions:		CASH AMOUNT R		PAID YES NO		Confirmation of Delivery: <input type="checkbox"/>	
						Tick to select limited liability option (to a maximum amount of R50 000) for non-excluded articles: <input type="checkbox"/>	
						Customs Value ZAR: []	
						Value of Article ZAR: []	
						Account to be Debited: JB6925	
						Sender's Ref. / Bag No.:	
						RECEIVED IN GOOD ORDER AND CONDITION	
						Receiver's Signature: [Signature]	
						Print Name: [Name]	
						Date: 21/10/18	
						Time: 9:41	

DAWN WING

A Division of DPD Laser Express Logistics (Pty) Ltd
Reg. No. 2006/013251/07 VAT No. 4690215250
FSP NO 32009

*All weight and dimensions subject to verification through electronic weight and dimension machine (SABS calibrated)

PROOF OF DELIVERY

25 October 2018

Ms Andrea van Gensen
Regional Environmental Manager
Eskom Holdings SOC Ltd
120 Henry Street
BLOEMFONTEIN 9301

Per Courier

Dear Ms Van Gensen,

**ENVIRONMENTAL IMPACT ASSESSMENT AND PUBLIC PARTICIPATION PROCESSES FOR THE PROPOSED
HYPERION SOLAR DEVELOPMENT 1, 2, 3 and 4 AND ASSOCIATED INFRASTRUCTURES NEAR KATHU,
NORTHERN CAPE PROVINCE**

NOTICE OF AVAILABILITY OF THE SCOPING REPORTS FOR REVIEW AND WRITTEN COMMENTS

The development of four (4) separate photovoltaic (PV) solar energy facilities (SEFs) as well as associated infrastructure are being proposed on the Remaining Extent of the Farm Lyndoch 432 situated ~16km north of Kathu in the Northern Cape Province. The proposed SEFs fall within the jurisdiction of the Gamagara Local Municipality and within the greater John Taolo Gaetsewe District Municipality.

Each of the four (4) SEFs will be constructed as separate stand-alone projects, with a separate project development company (or Special Purpose Vehicle) as the applicant for each project. The projects are:

Project Name:	Applicant:
Hyperion Solar Development 1	Hyperion Solar Development 1 (Pty) Ltd
Hyperion Solar Development 2	Cyraguard (Pty) Ltd
Hyperion Solar Development 3	Nomispan (Pty) Ltd
Hyperion Solar Development 4	Nomispan (Pty) Ltd

This letter serves to inform you that the Scoping Reports (SRs) are available for your Company's view and written comments, and a CD containing the SRs is included in this envelope.

Please note that the SRs' review period is from **Friday, 26 October 2018** to **Monday, 26 November 2018** and we are looking forward receiving your Company's written comment on the SRs before or on the closing date of the review period.

Kind regards



Nicolene Venter
Public Participation and Social Consultant
Savannah Environmental



a division of dpd LASER

0861 223 224
www.dawnwing.co.za



1298110660

WAYBILL

Sender to complete yellow areas only

FROM: SAVANNAH ENVIRO S A		Contents CD		HAZARDOUS YES NO		Filing Ref: 2167	
Address 1ST FLOOR. BLOCK 2 5 WOODLANDS DRIVE WOODMEAD		PARCEL DETAILS		SERVICE (mark only one)			
City/Country WOODMEAD		Postal Code must be filled in 2128		No. of Parcels ①	Vol(kg)-T's & C's Apply*	Mass(kg)-T's & C's Apply* opposite	<input checked="" type="checkbox"/> Overnight Express <input type="checkbox"/> Economy Cargo <input type="checkbox"/> Domestic Road Freight <input type="checkbox"/> Sameday Express
Senders Name LISA		Phone 011 6563237		Dimensions (cm) 40 30 1		<input type="checkbox"/> International Documents <input type="checkbox"/> International Non Documents <input type="checkbox"/> International Air Freight <input type="checkbox"/> International Road Freight	
TO: Eskom Holdings Soc Ltd		Street Address (P.O. Box Addresses not accepted) Do Henry Street		Dawn Wing reserves the right to mark the service "Overnight Express" should no service level be selected		SPECIAL INSTRUCTIONS	
City/Country Bloemfontein		Postal Code must be filled in 9301		Terms strictly 30 days from date of statement		<input type="checkbox"/> Saturday Delivery Collection <input type="checkbox"/> Dawn Delivery 9H00 / Time Required <input type="checkbox"/> After Hours <input type="checkbox"/> Sunday / Public Holiday <input type="checkbox"/> Confirmation of Delivery	
Receiver's Name Andriess van Gensen		Phone 082-482-7519		CASH AMOUNT R		PAID YES NO	
By signing this waybill the sender is concluding a contract with Dawn Wing and warrants his authority to enter into this contract and to bind the entity, which he/she represents. The terms and conditions of this contract are contained on the reverse of the sender's copy.		Senders Name Georgina		Date 25-10-18		Receivers Signature:	
Signature 		Collected By Courier 		Date 		Print Name: NATHANSE MOENG	
Special Instructions		Date 29/10/18		Time 08:40		Date: 29/10/18 Time: 08:40	

DAWN WING
A Division of DPD Laser Express Logistics (Pty) Ltd
Reg. No. 2006/033353/07 VAT No. 4690235280
FSP NO 32009

*All weight and dimensions subject to verification through electronic weight and dimension machine (SABS calibrated)

PROOF OF DELIVERY

25 October 2018

Mr John Geeringh
Senior Environmental Manager
Eskom Holdings SOC Ltd
Maxwell Office Park
SUNNINGHILL

Collect at Savannah Environmental

Dear Mr Geeringh,

**ENVIRONMENTAL IMPACT ASSESSMENT AND PUBLIC PARTICIPATION PROCESSES FOR THE PROPOSED
HYPERION SOLAR DEVELOPMENT 1, 2, 3 and 4 AND ASSOCIATED INFRASTRUCTURES NEAR KATHU,
NORTHERN CAPE PROVINCE**

NOTICE OF AVAILABILITY OF THE SCOPING REPORTS FOR REVIEW AND WRITTEN COMMENTS

The development of four (4) separate photovoltaic (PV) solar energy facilities (SEFs) as well as associated infrastructure are being proposed on the Remaining Extent of the Farm Lyndoch 432 situated ~16km north of Kathu in the Northern Cape Province. The proposed SEFs fall within the jurisdiction of the Gamagara Local Municipality and within the greater John Taolo Gaetsewe District Municipality.

Each of the four (4) SEFs will be constructed as separate stand-alone projects, with a separate project development company (or Special Purpose Vehicle) as the applicant for each project. The projects are:

Project Name:	Applicant:
Hyperion Solar Development 1	Hyperion Solar Development 1 (Pty) Ltd
Hyperion Solar Development 2	Cyraguard (Pty) Ltd
Hyperion Solar Development 3	Nomispank (Pty) Ltd
Hyperion Solar Development 4	Nomispan (Pty) Ltd

This letter serves to inform you that the Scoping Reports (SRs) are available for your Company's review and written comments, and a CD containing the SRs is included in this envelope.

Please note that the SRs' review period is from **Friday, 26 October 2018** to **Monday, 26 November 2018** and we are looking forward receiving your Company's written comment on the SRs before or on the closing date of the review period.

Kind regards



Nicolene Venter

Public Participation and Social Consultant

Savannah Environmental

25 October 2018

Mr Thusoeng Itumeleng
Municipal Manager
Gamagara Local Municipality
Civic Centre
Cnr Hendrick van Eck & Frikkie Meyer Road
KATHU 8446

Per Courier

Dear Mr Itumeleng,

**ENVIRONMENTAL IMPACT ASSESSMENT AND PUBLIC PARTICIPATION PROCESSES FOR THE PROPOSED
HYPERION SOLAR DEVELOPMENT 1, 2, 3 and 4 AND ASSOCIATED INFRASTRUCTURES NEAR KATHU,
NORTHERN CAPE PROVINCE**

NOTICE OF AVAILABILITY OF THE SCOPING REPORTS FOR REVIEW AND WRITTEN COMMENTS

The development of four (4) separate photovoltaic (PV) solar energy facilities (SEFs) as well as associated infrastructure are being proposed on the Remaining Extent of the Farm Lyndoch 432 situated ~16km north of Kathu in the Northern Cape Province. The proposed SEFs fall within the jurisdiction of the Gamagara Local Municipality and within the greater John Taolo Gaetsewe District Municipality.

Each of the four (4) SEFs will be constructed as separate stand-alone projects, with a separate project development company (or Special Purpose Vehicle) as the applicant for each project. The projects are:

Project Name:	Applicant:
Hyperion Solar Development 1	Hyperion Solar Development 1 (Pty) Ltd
Hyperion Solar Development 2	Cyraguard (Pty) Ltd
Hyperion Solar Development 3	Nomispank (Pty) Ltd
Hyperion Solar Development 4	Nomispan (Pty) Ltd

This letter serves to inform you that the Scoping Reports (SRs) are available for Gamagara Local Municipality's review and written comments, and a CD containing the SRs is included in this envelope.

Please note that the SRs' review period is from **Friday, 26 October 2018** to **Monday, 26 November 2018** and we are looking forward receiving Gamagara Local Municipality's written comment on the SRs before or on the closing date of the review period.

Kind regards



Nicolene Venier
Public Participation and Social Consultant
Savannah Environmental



global express

A Division of DPO Laser Express Logistics (Pty) Ltd

0861 223 224

www.dawnwing.co.za



1298110645

WAYBILL

FROM: SAVANNAH ENVIRO S A		Codebook CD		HAZARDOUS YES NO		Filing Ref: 2167	
Address 1ST FLOOR BLOCK 2 5 WOODLANDS DRIVE WOODMEAD		PARCEL DETAILS		SERVICE (mark only one)			
City/Township WOODMEAD		Postal Code 2128		No of Parcels 1		Weight (kg) 40	
Receiver Name LISA		Phone No 011 6563237		Dimensions (cm) 30 1 1		Special Instructions 1	
TO: GamaSara Local Municipality		Address (P.O. Box, if possible, for accuracy) Civic Centre! Cnr Hendrick van Eck & Frikkie Meyer Road		Dawn Wing reserves the right to mark the service "Overnight Express" should no service level be selected		RECEIVED IN GOOD ORDER AND CONDITION	
City/Township Kathu		Postal Code 2646		Terms strictly 30 days from date of statement		Receiver's Signature: 	
Receiver's Name Thuseane Ikumehene		Phone No 053-723-600		CASH AMOUNT R		PAID YES NO	
Senders Name SANTINING		Date 23/11/18		Confessed By Courier PACINA		Date 29/11/18	
Signature 		Time 12:05		Special Instructions		Print Name: Trinity	

DAWN WING

A Division of DPO Laser Express Logistics (Pty) Ltd
Reg. No. 2006/013363/07 VAT No. 4890221280
PSP NO 127219

*All weight and dimensions subject to verification through
electronic weight and dimension machine (SABS calibrated)

PROOF OF DELIVERY



11052018 1298110645 1298110645 1298110645

25 October 2018

Mr Disang Molaole
Municipal Manager
John Taolo Gaetsewe District Municipality
4 Federale Mynbou Street
KURUMAN 8460

Per Courier

Dear Mr Molaole,

**ENVIRONMENTAL IMPACT ASSESSMENT AND PUBLIC PARTICIPATION PROCESSES FOR THE PROPOSED
HYPERION SOLAR DEVELOPMENT 1, 2, 3 and 4 AND ASSOCIATED INFRASTRUCTURES NEAR KATHU,
NORTHERN CAPE PROVINCE**

NOTICE OF AVAILABILITY OF THE SCOPING REPORTS FOR REVIEW AND WRITTEN COMMENTS

The development of four (4) separate photovoltaic (PV) solar energy facilities (SEFs) as well as associated infrastructure are being proposed on the Remaining Extent of the Farm Lyndoch 432 situated ~16km north of Kathu in the Northern Cape Province. The proposed SEFs fall within the jurisdiction of the Gamagara Local Municipality and within the greater John Taolo Gaetsewe District Municipality.

Each of the four (4) SEFs will be constructed as separate stand-alone projects, with a separate project development company (or Special Purpose Vehicle) as the applicant for each project. The projects are:

Project Name:	Applicant:
Hyperion Solar Development 1	Hyperion Solar Development 1 (Pty) Ltd
Hyperion Solar Development 2	Cyraguard (Pty) Ltd
Hyperion Solar Development 3	Nomispank (Pty) Ltd
Hyperion Solar Development 4	Nomispan (Pty) Ltd

This letter serves to inform you that the Scoping Reports (SRs) are available for John Taolo Gaetsewe District Municipality's review and written comments, and a CD containing the SRs is included in this envelope.

Please note that the SRs' review period is from **Friday, 26 October 2018** to **Monday, 26 November 2018** and we are looking forward receiving Taolo Gaetsewe District Municipality's written comment on the SRs before or on the closing date of the review period.

Kind regards



Nicolene Venter
Public Participation and Social Consultant
Savannah Environmental



0861 223 224

www.dawnwing.co.za



1298110634

WAYBILL

Sender to complete yellow areas only

FROM: SAVANNAH ENVIRO S A		Country: <u>cd</u>		HAZARDOUS YES <input type="checkbox"/> NO <input checked="" type="checkbox"/>		Filing Ref: <u>2167</u>	
Address: 1ST FLOOR BLOCK 2 5 WOODLANDS DRIVE WOODMEAD		City/Country: WOODMEAD		Postal Code: 2128		PARCEL DETAILS	
Customer Name: LISA		Phone No: 011 6563237		No. of Parcels: <u>0</u>		Weight (kg): <u>opsky</u>	
TO: John Tsalo Gqebsus Doo		Street Address (P.O. Box addresses not permitted): St Municipality: 4 federale Mynbou Street		City/Country: KURUMAN		Postal Code: 8260	
Receiver's Name: Mr Dione Molele		Phone No: 053-712-8100		Special Instructions: Dawn Wing reserves the right to mark the service "Overnight Express" should no service level be selected		SPECIAL INSTRUCTIONS	
Signature: 		Date: 25-10-18		Collected By: 		Date: 26/10/18	
CASH AMOUNT R: <input type="text"/>		PAID YES <input type="checkbox"/> NO <input type="checkbox"/>		Terms strictly 30 days from date of statement		RECEIVED IN GOOD ORDER AND CONDITION	
Special Instructions:		Receiver's Signature: 		Print Name: Kestelogue		Date: 26/10/18	

DAWN WING
A Division of DPO Laxar Express Logistics (Pty) Ltd
Reg. No. 2016/0111267 VAT No. 420212781
FSP NO. 12019

*All weight and dimensions subject to verification through electronic weight and dimension machine (SABS calibrated)

PROOF OF DELIVERY

Document: PAK0018-PAK0018-01 (01/01/2018)

25 October 2018

Mr Tamai Hore
Senior Engineer: Generation Licensing
National Energy Regulator of South Africa
Kulawula House
526 Madiba Street
ARCADIA 0083

Per Courier

Dear Mr Hore,

**ENVIRONMENTAL IMPACT ASSESSMENT AND PUBLIC PARTICIPATION PROCESSES FOR THE PROPOSED
HYPERION SOLAR DEVELOPMENT 1, 2, 3 and 4 AND ASSOCIATED INFRASTRUCTURES NEAR KATHU,
NORTHERN CAPE PROVINCE**

NOTICE OF AVAILABILITY OF THE SCOPING REPORTS FOR REVIEW AND WRITTEN COMMENTS

The development of four (4) separate photovoltaic (PV) solar energy facilities (SEFs) as well as associated infrastructure are being proposed on the Remaining Extent of the Farm Lyndoch 432 situated ~16km north of Kathu in the Northern Cape Province. The proposed SEFs fall within the jurisdiction of the Gamagara Local Municipality and within the greater John Taolo Gaetsewe District Municipality.

Each of the four (4) SEFs will be constructed as separate stand-alone projects, with a separate project development company (or Special Purpose Vehicle) as the applicant for each project. The projects are:

Project Name:	Applicant:
Hyperion Solar Development 1	Hyperion Solar Development 1 (Pty) Ltd
Hyperion Solar Development 2	Cyraguard (Pty) Ltd
Hyperion Solar Development 3	Nomispank (Pty) Ltd
Hyperion Solar Development 4	Nomispan (Pty) Ltd

This letter serves to inform you that the Scoping Reports (SRs) are available for your Department's view and written comments, and a CD containing the SRs is included in this envelope.

Please note that the SRs' review period is from **Friday, 26 October 2018** to **Monday, 26 November 2018** and we are looking forward receiving your Department's written comment on the SRs before or on the closing date of the review period.

Kind regards



Nicolene Venter

**Public Participation and Social Consultant
Savannah Environmental**



0861 223 224
www.dawnwing.co.za



1298110726

WAYBILL

Sender to complete yellow areas only

FROM: SAVANNAH ENVIRO S A		Contents CD		HAZARDOUS YES NO		Filing Ref: 2167	
Address 1ST FLOOR. BLOCK 2 5 WOODLANDS DRIVE WOODMEAD		PARCEL DETAILS No. of Parcels: ① Vol(kg)-T's & C's Apply* Mass(kg)-T's & C's Apply* 0.15 kg Dimensions (cm): 40, 30, 1		SERVICE (mark only one) <input checked="" type="checkbox"/> Overnight Express <input type="checkbox"/> Economy Cargo <input type="checkbox"/> Domestic Road Freight <input type="checkbox"/> Sameday Express <input type="checkbox"/> International Documents <input type="checkbox"/> International Non Documents <input type="checkbox"/> International Air Freight <input type="checkbox"/> International Road Freight			
City/Country WOODMEAD		Postal Code must be filled in 2128		SPECIAL INSTRUCTIONS <input type="checkbox"/> Saturday Delivery Collection <input type="checkbox"/> Dawn Delivery (WFO) / Time Required <input type="checkbox"/> After Hours <input type="checkbox"/> Sunday / Public Holiday <input type="checkbox"/> Confirmation of Delivery Tick to select limited liability option (to a maximum amount of R50 000) for non-excluded articles <input type="checkbox"/>			
Senders Name LISA		Tel 011 6563237		Customs Value ZAR Value of Article ZAR			
TO: National Energy Regulator of South Africa		Street Address (P.O. Box Addresses not accepted) Kulawula House! 526 Mediba Street		Account to be Debited JB6925			
City/Country Arcadia		Postal Code must be filled in 20083		Sender's Ref. / Bag No.			
Receiver's Name Tamaal Hore		Tel 019-036-9294		RECEIVED IN GOOD ORDER AND CONDITION			
Andrew Timobny		012-4014053		Receivers Signature: Betty			
By signing this waybill the sender is concluding a contract with Dawn Wing and warrants his authority to enter into this contract and to bind the entity, which he/she represents. The terms and conditions of this contract are contained on the reverse of the sender's copy.							
Senders Name Georgina		Date 25.12.18		Collected By Courier MESA		Date 27/12/18	
Signature		Time		Time		Time	
CASH AMOUNT R				PAID YES NO			
Special Instructions							
Dawn Wing reserves the right to mark the service "Overnight Express" should no service level be selected							
Terms strictly 30 days from date of statement							
Date: 27/12/18 Time: 10:43							

DAWN WING
A Division of DPD Laser Express Logistics (Pty) Ltd
Reg. No. 2006/033353/07 VAT No. 4690235280
FSP NO 32009

*All weight and dimensions subject to verification through electronic weight and dimension machine (SABS calibrated)

PROOF OF DELIVERY

25 October 2018

Mr Ratha Andrew Timothy
Senior Engineer: Generation Licensing
National Energy Regulator of South Africa
Kulawula House
526 Madiba Street
ARCADIA 0083

Per Courier

Dear Mr Timothy,

**ENVIRONMENTAL IMPACT ASSESSMENT AND PUBLIC PARTICIPATION PROCESSES FOR THE PROPOSED
HYPERION SOLAR DEVELOPMENT 1, 2, 3 and 4 AND ASSOCIATED INFRASTRUCTURES NEAR KATHU,
NORTHERN CAPE PROVINCE**

NOTICE OF AVAILABILITY OF THE SCOPING REPORTS FOR REVIEW AND WRITTEN COMMENTS

The development of four (4) separate photovoltaic (PV) solar energy facilities (SEFs) as well as associated infrastructure are being proposed on the Remaining Extent of the Farm Lyndoch 432 situated ~16km north of Kathu in the Northern Cape Province. The proposed SEFs fall within the jurisdiction of the Gamagara Local Municipality and within the greater John Taolo Gaetsewe District Municipality.

Each of the four (4) SEFs will be constructed as separate stand-alone projects, with a separate project development company (or Special Purpose Vehicle) as the applicant for each project. The projects are:

Project Name:	Applicant:
Hyperion Solar Development 1	Hyperion Solar Development 1 (Pty) Ltd
Hyperion Solar Development 2	Cyraguard (Pty) Ltd
Hyperion Solar Development 3	Nomispank (Pty) Ltd
Hyperion Solar Development 4	Nomispan (Pty) Ltd

This letter serves to inform you that the Scoping Reports (SRs) are available for your Organisation's view and written comments, and a CD containing the SRs is included in this envelope.

Please note that the SRs' review period is from **Friday, 26 October 2018** to **Monday, 26 November 2018** and we are looking forward receiving your Organisation's written comment on the SRs before or on the closing date of the review period.

Kind regards



Nicolene Venter
Public Participation and Social Consultant
Savannah Environmental



0861 223 224
www.dawnwing.co.za



1298110726

WAYBILL

Sender to complete yellow areas only

FROM: SAVANNAH ENVIRO S A		Contents CD		HAZARDOUS YES NO		Filing Ref: 2167	
Address 1ST FLOOR. BLOCK 2 5 WOODLANDS DRIVE WOODMEAD		PARCEL DETAILS No. of Parcels: ① Vol(kg)-T's & C's Apply* Mass(kg)-T's & C's Apply* 0.15 kg Dimensions (cm) 40 30 1 ①		SERVICE (mark only one) Overnight Express <input checked="" type="checkbox"/> Economy Cargo Domestic Road Freight Sameday Express International Documents International Non Documents International Air Freight International Road Freight			
City/Country WOODMEAD		Postal Code must be filled in 2128		SPECIAL INSTRUCTIONS Saturday Delivery Collection Dawn Delivery 9100 / Time Required After Hours Sunday / Public Holiday Confirmation of Delivery			
Senders Name LISA		Tel 011 6563237		Tick to select limited liability option (to a maximum amount of R50 000) for non-excluded articles <input type="checkbox"/>			
TO: National Energy Regulator of South Africa		Street Address (P.O. Box Addresses not accepted) Kulawula House! 526 Mediba Street		Customs Value ZAR Value of Article ZAR			
City/Country Arcadia		Postal Code must be filled in 20083		Account to be Debited JB6925			
Receiver's Name Tamaal Hore Andrew Timothy		Tel 019-036-9294 012-4014053		Sender's Ref. / Bag No.			
By signing this waybill the sender is concluding a contract with Dawn Wing and warrants his authority to enter into this contract and to bind the entity, which he/she represents. The terms and conditions of this contract are contained on the reverse of the sender's copy.		Dawn Wing reserves the right to mark the service "Overnight Express" should no service level be selected		RECEIVED IN GOOD ORDER AND CONDITION			
Senders Name Georgina		Date 25.12.18		Collected By Courier MESA		Date 29/12/18	
Signature [Signature]		Time [Time]		Time [Time]		Time 10:43	
CASH AMOUNT R [] PAID YES NO		Terms strictly 30 days from date of statement		Receivers Signature: Betty Print Name: [Signature]			
Special Instructions		Dawn Wing reserves the right to mark the service "Overnight Express" should no service level be selected		Date: 29/12/18 Time: 10:43			

DAWN WING
A Division of DPD Laser Express Logistics (Pty) Ltd
Reg. No. 2006/033353/07 VAT No. 4690235280
FSP NO 32009

*All weight and dimensions subject to verification through electronic weight and dimension machine (SABS calibrated)

PROOF OF DELIVERY

25 October 2018

Mr Bryan Fisher
Director: Environmental Quality Management
Northern Cape Department of Environment and Nature Conservation
Sasko Building
90 Long Street
KIMBERLEY 8301

Per Courier

Dear Mr Fisher,

**ENVIRONMENTAL IMPACT ASSESSMENT AND PUBLIC PARTICIPATION PROCESSES FOR THE PROPOSED
HYPERION SOLAR DEVELOPMENT 1 AND ASSOCIATED INFRASTRUCTURES NEAR KATHU, NORTHERN
CAPE PROVINCE**

NOTICE OF AVAILABILITY OF THE SCOPING REPORT FOR REVIEW AND WRITTEN COMMENTS

Hyperion Solar Development 1 (Pty) Ltd, the developer, is proposing the development of the Hyperion Solar Photovoltaic (PV) 1 solar energy facility and associated infrastructure on the Remaining Extent of the Farm Lyndoch 432 situated ~16km north of Kathu in the Northern Cape Province. The proposed development falls within the jurisdiction of the Gamagara Local Municipality and within the greater John Taolo Gaetsewe District Municipality.

This letter serves to inform you that the Scoping Report (SR) is available for your Department's review and written comments, and a hard copy and CD containing the SR is included in this envelope.

Please note that the SR's review period is from **Friday, 26 October 2018** to **Monday, 26 November 2018** and we are looking forward receiving your Department's written comment on the SR before or on the closing date of the review period.

Kind regards



Nicolene Venter
Public Participation and Social Consultant
Savannah Environmental



a division of dpd LASER

0861 223 224
www.dawnwing.co.za

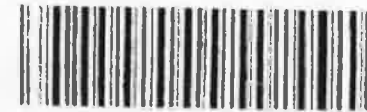

1298110693

WAYBILL

Sender to complete yellow areas only

FROM: SAVANNAH ENVIRO S A		Contents: HAZARDOUS YES NO		Filing Ref: 2167	
Address: 1ST FLOOR, BLOCK 2 5 WOODLANDS DRIVE WOODMEAD		PARCEL DETAILS		SERVICE (mark only one)	
City/Country: WOODMEAD		No. of Parcels: 1	Volume: T's & C's Apply	Mass: T's & C's Apply: 7.85kg	<input checked="" type="checkbox"/> Express
Postal Code: 2128		Dimensions (cm): 20 30 10		<input type="checkbox"/> International Documents	<input type="checkbox"/> International Non-Documents
Senders Name: LISA		Postal Code must be filled in: 2128		SPECIAL INSTRUCTIONS	
TO: Department of Environment and Nature Conservation, SASTA Building, 90 King Street		Dawn Wing reserves the right to mark the service "Overnight Express" should no service level be selected		Tick to select limited liability option (to a maximum amount of R50 000) for non-excluded articles <input type="checkbox"/>	
City/Country: Kimberley		Receiver's Name: Mr Bryan Fisher		Customs Value ZAR: _____	
Postal Code: 8301		Date: 25-12-18		Value of Article ZAR: _____	
Signature: [Signature]		Collected By Courier: [Signature]		Account to be Debited: JB6925	
Date: 25-12-18		Time: 10:25		Sender's Ref / Bag No: _____	
Time: _____		Time: _____		RECEIVED IN GOOD ORDER AND CONDITION	
By signing this waybill the sender is concluding a contract with Dawn Wing and warrants his authority to enter into this contract and to bind the entity, which he/she represents. The terms and conditions of this contract are contained on the reverse of the sender's copy.		Terms strictly 30 days from date of statement		Receiver's Signature: [Signature]	
Senders Name: [Signature]		Date: 25-12-18		Print Name: Rule	
Signature: [Signature]		Time: _____		Date: 21/12/18	
Time: _____		Time: _____		Time: 10:25	

DAWN WING

A Division of DPD Laser Express Logistics (Pty) Ltd
Reg. No. 2006/033353/07 VAT No. 4690235280
FSP NO 32029

*All weight and dimensions subject to verification through electronic weight and dimension machine (SABS calibrated)

PROOF OF DELIVERY

25 October 2018

Ms Samantha De la Fontaine
Production Scientists Grade A: District Ecologist
Department of Environment and Nature Conservation: Northern Cape
1st Floor, Provincial Building
Cnr Rivier & Nelson Mandela Roads
UPINGTON 8800

Per Courier

Dear Ms De la Fontaine,

**ENVIRONMENTAL IMPACT ASSESSMENT AND PUBLIC PARTICIPATION PROCESSES FOR THE PROPOSED
HYPERION SOLAR DEVELOPMENT 1, 2, 3 and 4 AND ASSOCIATED INFRASTRUCTURES NEAR KATHU,
NORTHERN CAPE PROVINCE**

NOTICE OF AVAILABILITY OF THE SCOPING REPORTS FOR REVIEW AND WRITTEN COMMENTS

The development of four (4) separate photovoltaic (PV) solar energy facilities (SEFs) as well as associated infrastructure are being proposed on the Remaining Extent of the Farm Lyndoch 432 situated ~16km north of Kathu in the Northern Cape Province. The proposed SEFs fall within the jurisdiction of the Gamagara Local Municipality and within the greater John Taolo Gaetsewe District Municipality.

Each of the four (4) SEFs will be constructed as separate stand-alone projects, with a separate project development company (or Special Purpose Vehicle) as the applicant for each project. The projects are:

Project Name:	Applicant:
Hyperion Solar Development 1	Hyperion Solar Development 1 (Pty) Ltd
Hyperion Solar Development 2	Cyraguard (Pty) Ltd
Hyperion Solar Development 3	Nomispank (Pty) Ltd
Hyperion Solar Development 4	Nomispan (Pty) Ltd

This letter serves to inform you that the Scoping Reports (SRs) are available for your Department's review and written comments, and a CD containing the SRs is included in this envelope.

Please note that the SRs' review period is from **Friday, 26 October 2018** to **Monday, 26 November 2018** and we are looking forward receiving your Department's written comment on the SRs before or on the closing date of the review period.

Kind regards



Nicolene Venter
Public Participation and Social Consultant
Savannah Environmental



0861 223 224
www.dawnwing.co.za



1298110671

WAYBILL

Sender to complete yellow areas only

FROM: SAVANNAH ENVIRO S A

Address: 1ST FLOOR, BLOCK 2
5 WOODLANDS DRIVE
WOODMEAD

City/County: WOODMEAD

Postal Code: 2128

Phone No: 011 6563237

TO: Department of Environment
and Nature Conservation;
1st Floor, Provincial Building, enl
Rivers & Nelson Mandela Road

City/County: 8800

Receiver's Name: Ms Neda Fontaine 012-862-5678

Signature: [Signature]

Collected by Courier: [Signature]

Comments: cd

HAZARDOUS YES NO

Filing Ref: 2167

PARCEL DETAILS				SERVICE (mark only one)			
No. of Parcels	Weight & Dim (kg)	Volume (m³)	Special	Standard	Next Day	Overnight	Special
1	40	30	1	<input checked="" type="checkbox"/>	<input type="checkbox"/>	<input type="checkbox"/>	<input type="checkbox"/>

SPECIAL INSTRUCTIONS

Take the weight of items of liability online (for a maximum amount of R50 000) for non-watched articles

Customs Value: ZAR

Value of article: ZAR

Account to be Debited: JB6925

Sender's Ref: Bag No

RECEIVED IN GOOD OR AND CONDITION

Receiver's Signature: [Signature]

Print Name: S. V. H. WEST HILL

Date: 2/10/18

Time: 12

PROOF OF DELIVERY

CASH AMOUNT R PAID YES NO

Terms strictly 30 days from date of statement

Dawn Wing reserves the right to mark the service "Overnight Express" should no service level be selected

*All weight and dimensions subject to verification through electronic weight and dimension machine (SABS calibrated)

DAWN WING
A Division of DPD Laser Express Logistics (Pty) Ltd
Reg. No. 2005/033353/07 VAT No. 4920274280
FSP NO 24004

25 October 2018

Mr Jaco Roelofse
Director: Roads
Department of Roads and Public Works
45 Schmidtsdrift Road
KIMBERLEY 8301

Per Courier

Dear Mr Roelofse,

**ENVIRONMENTAL IMPACT ASSESSMENT AND PUBLIC PARTICIPATION PROCESSES FOR THE PROPOSED
HYPERION SOLAR DEVELOPMENT 1, 2, 3 and 4 AND ASSOCIATED INFRASTRUCTURES NEAR KATHU,
NORTHERN CAPE PROVINCE**

NOTICE OF AVAILABILITY OF THE SCOPING REPORTS FOR REVIEW AND WRITTEN COMMENTS

The development of four (4) separate photovoltaic (PV) solar energy facilities (SEFs) as well as associated infrastructure are being proposed on the Remaining Extent of the Farm Lyndoch 432 situated ~16km north of Kathu in the Northern Cape Province. The proposed SEFs fall within the jurisdiction of the Gamagara Local Municipality and within the greater John Taolo Gaetsewe District Municipality.

Each of the four (4) SEFs will be constructed as separate stand-alone projects, with a separate project development company (or Special Purpose Vehicle) as the applicant for each project. The projects are:

Project Name:	Applicant:
Hyperion Solar Development 1	Hyperion Solar Development 1 (Pty) Ltd
Hyperion Solar Development 2	Cyraguard (Pty) Ltd
Hyperion Solar Development 3	Nomispan (Pty) Ltd
Hyperion Solar Development 4	Nomispan (Pty) Ltd

This letter serves to inform you that the Scoping Reports (SRs) are available for your Department's review and written comments, and a CD containing the SRs is included in this envelope.

Please note that the SRs' review period is from **Friday, 26 October 2018** to **Monday, 26 November 2018** and we are looking forward receiving your Department's written comment on the SRs before or on the closing date of the review period.

Kind regards



Nicolene Venter
Public Participation and Social Consultant
Savannah Environmental



a division of DPD LASER

0861 223 224

www.dawnwing.co.za

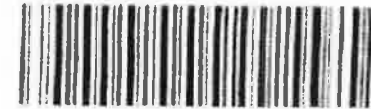

1298110586

WAYBILL

Sender to complete yellow areas only

FROM: SAVANNAH ENVIRO S A		Contents: CD		HAZARDOUS YES NO		Filing Ref: 2167	
Address: 1ST FLOOR, BLOCK 2 5 WOODLANDS DRIVE WOODMEAD		No. of Parcels: 1		Vol(kg)-T's & C's Apply: 0.156		SERVICE (mark only one)	
City/Country: WOODMEAD		Postal Code: 2128		Dimensions (cm): 40 30 1		<input checked="" type="checkbox"/> Domestic Road Freight <input type="checkbox"/> Economy Cargo <input type="checkbox"/> International Documents <input type="checkbox"/> International Air Freight <input type="checkbox"/> International Road Freight <input type="checkbox"/> Saturday Express	
Senders Name: LISA		Phone: 011 6563237		POD		SPECIAL INSTRUCTIONS	
TO: Department of Roads and public work: 45 SCHMIDTSCHIL FE ROAD		City/Country: Kimberley				Tick to select limited liability option (to a maximum amount of R50 000) for non-excluded articles: <input type="checkbox"/>	
City/Country: Kimberley		Postal Code: 8301		Dawn Wing reserves the right to mark the service "Overnight Express" should no service level be selected		Customs Value ZAR: _____ Value of Article ZAR: _____ Account to be Debited: JB6925 Sender's Ref. / Bag No: _____	
Receiver's Name: Mr Jacob Roeloffse		Phone: 076-911-6906		Terms strictly 30 days from date of statement		RECEIVED IN GOOD ORDER AND CONDITION	
By signing this waybill the sender is concluding a contract with Dawn Wing and warrants his authority to enter into this contract and to bind the entity, which herein represents. The terms and conditions of this contract are contained on the reverse of the sender's copy.		CASH AMOUNT R _____		PAID YES NO		Receiver's Signature:	
Senders Name: GABRIEL		Date: 25/10/18		Special Instructions:		Print Name: Donkulu	
Signature:		Collected By Courier:		Date: 26/10/18		Date: _____ Time: 10h15	

DAWN WING

A Division of DPD Laser Express Logistics (Pty) Ltd
 Reg. No. 2906-03335207 VAT No. 4690235280
 FSP NO 32009

*All weight and dimensions subject to verification through
 electronic weight and dimension machine (SABS calibrated)

PROOF OF DELIVERY

25 October 2018

Lieutenant Colonel Keasenosi Zondi
SO1 Military Integrated Environment Management
South African Defence Force
Armcor Building
Block 5, Level 4
Cnr Delmas Avenue & Nossob Streets
Erasmuskloof
PRETORIA 0001

Per Courier

Dear Lieutenant Colonel Zondi,

**ENVIRONMENTAL IMPACT ASSESSMENT AND PUBLIC PARTICIPATION PROCESSES FOR THE PROPOSED
HYPERION SOLAR DEVELOPMENT 1, 2, 3 and 4 AND ASSOCIATED INFRASTRUCTURES NEAR KATHU,
NORTHERN CAPE PROVINCE**

NOTICE OF AVAILABILITY OF THE SCOPING REPORTS FOR REVIEW AND WRITTEN COMMENTS

The development of four (4) separate photovoltaic (PV) solar energy facilities (SEFs) as well as associated infrastructure are being proposed on the Remaining Extent of the Farm Lyndoch 432 situated ~16km north of Kathu in the Northern Cape Province. The proposed SEFs fall within the jurisdiction of the Gamagara Local Municipality and within the greater John Taolo Gaetsewe District Municipality.

Each of the four (4) SEFs will be constructed as separate stand-alone projects, with a separate project development company (or Special Purpose Vehicle) as the applicant for each project. The projects are:

Project Name:	Applicant:
Hyperion Solar Development 1	Hyperion Solar Development 1 (Pty) Ltd
Hyperion Solar Development 2	Cyraguard (Pty) Ltd
Hyperion Solar Development 3	Nomispank (Pty) Ltd
Hyperion Solar Development 4	Nomispan (Pty) Ltd

This letter serves to inform you that the Scoping Reports (SRs) are available for your Department's review and written comments, and a CD containing the SRs is included in this envelope.

Please note that the SRs' review period is from **Friday, 26 October 2018** to **Monday, 26 November 2018** and we are looking forward receiving your Department's written comment on the SRs before or on the closing date of the review period.

Kind regards



Nicolene Venter
Public Participation and Social Consultant
Savannah Environmental



global express

a division of dpd LASER

0861 223 224

www.dawnwing.co.za

WAYBILL



1298110623

Sender to complete yellow areas only

FROM: SAVANNAH ENVIRO S A		Contents: CD		HAZARDOUS YES <input type="checkbox"/> NO <input type="checkbox"/>		Filing Ref: 267	
Address: 1ST FLOOR. BLOCK 2 5 WOODLANDS DRIVE WOODMEAD		No. of Parcels: 1		Vol(kg)-T's & C's Apply*		SERVICE (mark only one)	
City/Country: WOODMEAD		Dimensions (cm): 40 30 1		Mass(kg)-T's & C's Apply*: 0.05kg		<input checked="" type="checkbox"/> Overnight Express <input type="checkbox"/> Economy Cargo <input type="checkbox"/> Domestic Road Freight <input type="checkbox"/> Sameday Express	
Postal Code must be filled in: 2128		International Documents		International Non Documents		International Air Freight	
Senders Name: LISA		Phone: 011 6563237		SPECIAL INSTRUCTIONS		<input type="checkbox"/> Saturday Delivery Collection <input type="checkbox"/> Dawn Delivery 0900 / Time Required <input type="checkbox"/> Sunday / Public Holiday <input type="checkbox"/> Confirmation of Delivery	
TO: 501 Mill (at) Integrated Group Management Services Africa Defer		Street Address (P.O. Box Addresses not accepted): Ce Force! Fimscor Building Block 5, Level 4. Cnr De Meas Avenue & Nassob Streets. Erasmuskerf		Dawn Wing reserves the right to mark the service "Overnight Express" should no service level be selected		Tick to select limited liability option (to a maximum amount of R50 000) for non-excluded articles: <input type="checkbox"/> Customs Value ZAR: Value of Article ZAR: Account to be Debited: JB6925 Sender's Ref. / Bag No.:	
City/Country: Pretoria		Postal Code must be filled in: 0001		Terms strictly 30 days from date of statement		RECEIVED IN GOOD ORDER AND CONDITION	
Receiver's Name: Koedoes Zandi		Phone: 065-364-7985		CASH AMOUNT R <input type="text"/> PAID YES <input type="checkbox"/> NO <input type="checkbox"/>		Receivers Signature: Print Name: H.K. ZANDI	
By signing this waybill the sender is concluding a contract with Dawn Wing and warrants his authority to enter into this contract and to bind the entity, which he/she represents. The terms and conditions of this contract are contained on the reverse of the sender's copy.		Senders Name: [Signature]		Date: 25-10-18		Date: 03/11/18	
Signature: [Signature]		Collected By Courier: [Signature]		Date: 26/10		Time: 13:05	

DAWN WING
A Division of DPD Laser Express Logistics (Pty) Ltd
Reg. No. 2006/033353/07 VAT No. 469235280
FSP NO 32009

*All weight and dimensions subject to verification through electronic weight and dimension machine (SABS calibrated)

PROOF OF DELIVERY



25 October 2018

Ms Nicole Abrahams
Environmental Co-ordinator: Western Region
SA National Roads Agency Ltd
1 Havenga Street
Oakdale
BELLEVILLE 7530

Per Courier

Dear Ms Abrahams,

**ENVIRONMENTAL IMPACT ASSESSMENT AND PUBLIC PARTICIPATION PROCESSES FOR THE PROPOSED
HYPERION SOLAR DEVELOPMENT 1 AND ASSOCIATED INFRASTRUCTURES NEAR KATHU, NORTHERN
CAPE PROVINCE**

NOTICE OF AVAILABILITY OF THE SCOPING REPORT FOR REVIEW AND WRITTEN COMMENTS

Hyperion Solar Development 1 (Pty) Ltd, the developer, is proposing the development of the Hyperion Solar Photovoltaic (PV) 1 solar energy facility and associated infrastructure on the Remaining Extent of the Farm Lyndoch 432 situated ~16km north of Kathu in the Northern Cape Province. The proposed development falls within the jurisdiction of the Gamagara Local Municipality and within the greater John Taolo Gaetsewe District Municipality.

This letter serves to inform you that the Scoping Report (SR) is available for your Department's review and written comments, and a hard copy and CD containing the SR is included in this envelope.

Please note that the SR's review period is from **Friday, 26 October 2018** to **Monday, 26 November 2018** and we are looking forward receiving your Department's written comment on the SR before or on the closing date of the review period.

Kind regards



Nicolene Venter

**Public Participation and Social Consultant
Savannah Environmental**



a division of dpd LASER

0861 223 224

www.dawnwing.co.za



1298110682

WAYBILL

Sender to complete yellow areas only

FROM: SAVANNAH ENVIRO S A		Contents HG + CD		HAZARDOUS YES NO <small>IF YES, SEE REVERSE</small>		Filing Ref: 2167	
Address 1ST FLOOR. BLOCK 2 5 WOODLANDS DRIVE WOODMEAD		PARCEL DETAILS		SERVICE (mark only one)			
City/Country WOODMEAD		Postal Code must be filled in 2128		No. of Parcels 1	Vol(kg)-T's & C's Apply*	Mass(kg)-T's & C's Apply*	Overnight Express <input checked="" type="checkbox"/>
Senders Name LISA		011 6563237		Dimensions (cm) 40 30 1		Economy Cargo <input type="checkbox"/>	
TO: SA National Roads Agency		Street Address (P.O. Box Addresses not accepted) Nbd! 1 Havenga Street Oakdale		Dawn Wing reserves the right to mark the service "Overnight Express" should no service level be selected		Domestic Road Freight <input type="checkbox"/>	
City/Country Bellville		Postal Code must be filled in 7530		Terms strictly 30 days from date of statement		Saturday Delivery <input type="checkbox"/>	
Receiver's Name Nicole Abrahams		081-957-6602		CASH AMOUNT R		International Documents <input type="checkbox"/>	
By signing this waybill the sender is concluding a contract with Dawn Wing and warrants his authority to enter into this contract and to bind the entity, which he/she represents. The terms and conditions of this contract are contained on the reverse of the sender's copy.		Special Instructions		PAID YES NO		International Non Documents <input type="checkbox"/>	
Senders Name Georgina		Date 25-10-18		Collected By Courier PASA		International Air Freight <input type="checkbox"/>	
Signature [Signature]		Time		Date 26/10/18		International Road Freight <input type="checkbox"/>	
						SPECIAL INSTRUCTIONS	
						Saturday Delivery Collection <input type="checkbox"/>	
						Dawn Delivery 9H00 / Time Required <input type="checkbox"/>	
						After Hours <input type="checkbox"/>	
						Sunday / Public Holiday <input type="checkbox"/>	
						Confirmation of Delivery <input type="checkbox"/>	
						Tick to select limited liability option (to a maximum amount of R50 000) for non-excluded articles <input type="checkbox"/>	
						Customs Value ZAR	
						Value of Article ZAR	
						Account to be Debited JB6925	
						Sender's Ref. / Bag No.	
						RECEIVED IN GOOD ORDER AND CONDITION	
						Receivers Signature [Signature]	
						Print Name: [Signature]	
						Date: 29/10/18 Time: 8H05	

DAWN WING

A Division of DPD Laser Express Logistics (Pty) Ltd
Reg. No. 2006/033353/07 VAT No. 4690235280
FSP NO 32009

*All weight and dimensions subject to verification through electronic weight and dimension machine (SABS calibrated)

PROOF OF DELIVERY



25 October 2018

Dr Adriaan Tiplady
Manager: Site Categorisation
Square Kilometre Array
1st Floor
17 Baker Street
ROSEBANK 2196

Per Courier

Dear Dr Tiplady,

**ENVIRONMENTAL IMPACT ASSESSMENT AND PUBLIC PARTICIPATION PROCESSES FOR THE PROPOSED
HYPERION SOLAR DEVELOPMENT 1, 2, 3 and 4 AND ASSOCIATED INFRASTRUCTURES NEAR KATHU,
NORTHERN CAPE PROVINCE**

NOTICE OF AVAILABILITY OF THE SCOPING REPORTS FOR REVIEW AND WRITTEN COMMENTS

The development of four (4) separate photovoltaic (PV) solar energy facilities (SEFs) as well as associated infrastructure are being proposed on the Remaining Extent of the Farm Lyndoch 432 situated ~16km north of Kathu in the Northern Cape Province. The proposed SEFs fall within the jurisdiction of the Gamagara Local Municipality and within the greater John Taolo Gaetsewe District Municipality.

Each of the four (4) SEFs will be constructed as separate stand-alone projects, with a separate project development company (or Special Purpose Vehicle) as the applicant for each project. The projects are:

Project Name:	Applicant:
Hyperion Solar Development 1	Hyperion Solar Development 1 (Pty) Ltd
Hyperion Solar Development 2	Cyraguard (Pty) Ltd
Hyperion Solar Development 3	Nomispark (Pty) Ltd
Hyperion Solar Development 4	Nomispan (Pty) Ltd

This letter serves to inform you that the Scoping Reports (SRs) are available for your Department's review and written comments, and a CD containing the SRs, are included in this envelope.

Please note that the SRs' review period is from **Friday, 26 October 2018** to **Monday, 26 November 2018** and we are looking forward receiving your Department's written comment on the SRs before or on the closing date of the review period.

Kind regards



Nicolene Venter
Public Participation and Social Consultant
Savannah Environmental



0861 223 224
www.dawnwing.co.za



1298110531

WAYBILL

Sender to complete yellow areas only

FROM: SAVANNAH ENVIRO S A		Contents CD		HAZARDOUS YES NO		Filing Ref: 2167	
Address 1ST FLOOR. BLOCK 2 5 WOODLANDS DRIVE WOODMEAD		PARCEL DETAILS		SERVICE (mark only one)			
City/Country WOODMEAD		No. of Parcels 1		Vol(kg)-T's & C's Apply*		Overnight Express <input checked="" type="checkbox"/>	
Postal Code 2128		Dimensions (cm) 40 30 7		Mass(kg)-T's & C's Apply*		Economy Cargo <input type="checkbox"/>	
Senders Name LISA		Phone 011 6563237		International Documents <input type="checkbox"/>		Domestic Road Freight <input type="checkbox"/>	
TO: Manager Site Categorisation		Dawn Wing reserves the right to mark the service "Overnight Express" should no service level be selected		International Non Documents <input type="checkbox"/>		International Air Freight <input type="checkbox"/>	
Street Address (P.O. Box Addresses not accepted) Square kilometre Amay 1st Floor 17 Baker Street		Terms strictly 30 days from date of statement		International Road Freight <input type="checkbox"/>		Sameday Express <input type="checkbox"/>	
City/Country Rosebank		CASH AMOUNT R		PAID YES NO		SPECIAL INSTRUCTIONS	
Postal Code 2196		Special Instructions		Saturday Delivery Collection <input type="checkbox"/>		Saturday / Public Holiday Confirmation of Delivery <input type="checkbox"/>	
Receiver's Name Dr Advigaan Upthay		Phone 012-372-0134		Tick to select limited liability option (to a maximum amount of R50 000) for non-excluded articles <input type="checkbox"/>		Account to be Debited JB6925	
Signature [Signature]		Date 25-10-18		Customs Value ZAR		Value of Article ZAR	
Time [Signature]		Date 26/10/18		Sender's Ref. / Bag No.		RECEIVED IN GOOD ORDER AND CONDITION	
Time		Time		Receiver's Signature: [Signature]		Print Name: Lizzy	
Time		Time		Date 29/10/18		Time 9:20	

DAWN WING
A Division of DPD Laser Express Logistics (Pty) Ltd
Reg. No. 2008/033353/07 VAT No. 4690235280
FSP NO 32009

*All weight and dimensions subject to verification through electronic weight and dimension machine (SABS calibrated)

PROOF OF DELIVERY

CORRESPONDENCE AFTER NOTIFICATION OF
SCOPING REPORT FOR PUBLIC REVIEW AND
COMMENT

Rozanne Els

From: Rozanne Els <rozanne@savannahsa.com>
Sent: 05 November 2018 7:46 AM
To: 'bitsangk@gamagara.gov.za'
Subject: FW: Focus Group Meeting Hyperion solar PV facilities

Importance: High

Good day Lebo,

Please could you urgently respond to my emails below to secure the meeting.

Thank you and kind regards,

Rozanne Els

Public Participation Co-ordinator | Savannah Environmental (Pty) Ltd
Tel: +27 (0)11 656 3237 | Fax: +27 (0)86 684 0547

[SAWEA Award for Leading Environmental Consultant for Wind Projects in 2013 & 2015](#)

From: Rozanne Els [mailto:rozanne@savannahsa.com]
Sent: 02 November 2018 9:00 AM
To: 'bitsangk@gamagara.gov.za' <bitsangk@gamagara.gov.za>
Subject: Focus Group Meeting Hyperion solar PV facilities
Importance: High

Dear Lebo,

The emails below has reference,

I have been trying to call you, but seems that I cannot get hold of you.

Please could you let me know if the meeting will be possible and provide feedback as per emails below ?

Thank you for your assistance.

Kind regards,

Rozanne Els

Public Participation Co-ordinator | Savannah Environmental (Pty) Ltd
Tel: +27 (0)11 656 3237 | Fax: +27 (0)86 684 0547

[SAWEA Award for Leading Environmental Consultant for Wind Projects in 2013 & 2015](#)

From: Rozanne Els [mailto:rozanne@savannahsa.com]
Sent: 01 November 2018 11:03 AM
To: 'bitsangk@gamagara.gov.za' <bitsangk@gamagara.gov.za>
Subject: Focus Group Meeting Hyperion solar PV facilities
Importance: High

Good day Lebo,

Do you have any feedback on the email below yet ?

Kind regards,

Rozanne Els

Public Participation Co-ordinator | Savannah Environmental (Pty) Ltd

Tel: +27 (0)11 656 3237 | Fax: +27 (0)86 684 0547

[SAWEA Award for Leading Environmental Consultant for Wind Projects in 2013 & 2015](#)

From: Rozanne Els [<mailto:rozanne@savannahsa.com>]

Sent: 31 October 2018 12:15 PM

To: 'bitsangk@gamagara.gov.za' <bitsangk@gamagara.gov.za>

Subject: Focus Group Meeting Hyperion solar PV facilities

Importance: High

Dear Lebo,

I recall our earlier conversation per telephone.

We would like to arrange a meeting with the Municipal manager and other officials on the 9th of November 2018 at 09h00. Kindly confirm if this will be suitable ? Also if you could please arrange for the venue to take place at the Municipalities boardroom/chambers.

I will send a formal invitation with all the information by the end of the week.

Also, please could you provide me with your details so that I can update the project database ? we have the Municipal Manager's secretary as Ingrid de Koker.

Name:

Surname:

Designation:

Tel:

Cell:

Email Address:

Physical Address:

Also if you could confirm that the Municipal Manager's details that we have is correct:

Thusoeng Itumeleng

Municipal Manager

Tel: 053 723 6000

Email: clementi@gamagara.gov.za

Thank you and kind regards,

Rozanne Els

From: Nicolene Venter <nicolene@savannahsa.com>
Sent: 20 November 2018 7:35 AM
To: 'Msimango Philani (KBY)'
Cc: 'Rozanne Els'; 'Thalita Botha'
Subject: RE: Reminder: Hyperion Solar Notification of Availability of Scoping Report for public review

Dear Mr Msimango,

Thank you for the confirmation of receipt of the four (4) Scoping Reports by the Water Quality Management at DWS: Northern Cape Province.

We are looking forward to the Assessors' comments.

Kind regards,

Nicolene Venter

Public Participation & Social Consultant | Savannah Environmental (Pty) Ltd
Tel: +27 (0)11 656 3237 | Fax: +27 (0)86 684 0547

[SAWEA Award for Leading Environmental Consultant for Wind Projects in 2013 & 2015](#)

From: Msimango Philani (KBY) <Msimangop@dws.gov.za>
Sent: Tuesday, November 20, 2018 7:22 AM
To: Nicolene Venter <nicolene@savannahsa.com>
Cc: 'Rozanne Els' <rozanne@savannahsa.com>; 'Thalita Botha' <thalita@savannahsa.com>
Subject: RE: Reminder: Hyperion Solar Notification of Availability of Scoping Report for public review

Good Day

Kindly take note that the reports have been received by Water Quality Management on the 19th of November 2018 for four separate projects and each have been assigned to an assessor. The assessor will contact you once the reports have been assessed.

Also please take note that my surname is **Msimango** and not "Msimanga". I would appreciate it if you could address me accordingly next time.

Regards

Mr. Philani P. Msimango

BSc - Geological Sciences (UKZN); **BSc Hons - Geohydrology** (UFS-IGS)

Control Scientific Technician

Water Quality Management - Lower Vaal

Northern Cape Provincial Operations

E: msimangop@dws.gov.za

T: +27 53 836 7649

Private Bag X6101 | 28 Central Road | Beaconsfield | Kimberley | 8301

"The man that once did sell the lion's skin, While the beast lived was killed with hunting him" - William Shakespeare



From: Nicolene Venter [<mailto:nicolene@savannahsa.com>]
Sent: Friday, November 16, 2018 4:00 PM
To: Msimango Philani (KBY)
Cc: 'Rozanne Els'; 'Thalita Botha'
Subject: RE: Reminder: Hyperion Solar Notification of Availability of Scoping Report for public review

Dear Mr Msimanga,

I can confirm that I discussed the distribution of Environmental Impact Assessment and Basic Assessment Reports to the Department of Water and Sanitation (DWS): Northern Cape Province, with Mr Abe Abrahams.

It was confirmed that all Reports must please be addressed and sent to his Office and from there he will allocate it to the relevant DWS Case Officer and should DWS National needs a copy, he will send it to them.

I will be in contact with Mr Abrahams' Office on Monday to follow-up on the matter and will revert to you soon thereafter.

Kind regards,

Nicolene Venter

Public Participation & Social Consultant | Savannah Environmental (Pty) Ltd
Tel: +27 (0)11 656 3237 | Fax: +27 (0)86 684 0547

[SAWEA Award for Leading Environmental Consultant for Wind Projects in 2013 & 2015](#)

From: Msimango Philani (KBY) <MsimangoP@dws.gov.za>
Sent: Friday, November 16, 2018 1:56 PM
To: Savannah Environmental Public Process <publicprocess@savannahsa.com>
Cc: 'Nicolene Venter' <nicolene@savannahsa.com>
Subject: RE: Reminder: Hyperion Solar Notification of Availability of Scoping Report for public review

Good Day

Thank you for the response. Do you not receive an acknowledgement that it is being sent/delivered because normally we receive a notification stating that the email has been delivered to the recipient.

I will follow up with IT because there is no record of such an email at my disposal and I do not remember reading such an email. Also there is no records of the Reports being submitted to Water Quality Management but I will follow up with Registry, perhaps its an administrative error.

Regards

Mr. Philani P. Msimango

BSc - Geological Sciences (UKZN); **BSc Hons - Geohydrology** (UFS-IGS)

Control Scientific Technician

Water Quality Management - Lower Vaal

Northern Cape Provincial Operations

E: msimangop@dws.gov.za

T: +27 53 836 7649



From: Savannah Environmental Public Process [<mailto:publicprocess@savannahsa.com>]
Sent: Friday, November 16, 2018 1:50 PM
To: Msimango Philani (KBY)
Cc: 'Nicolene Venter'
Subject: Reminder: Hyperion Solar Notification of Availability of Scoping Report for public review

Good day,

Thank you for your email.

Please see attached the Proof of Email that the initial email was sent to you.

Kindly note that a CD and a Hard Copy was sent to the Department to Mr Abe Abrahams.
Waybill No.:1298110704

Kind regards,

Rozanne Els

Public Participation Co-ordinator | Savannah Environmental (Pty) Ltd
Tel: +27 (0)11 656 3237 | Fax: +27 (0)86 684 0547

[SAWEA Award for Leading Environmental Consultant for Wind Projects in 2013 & 2015](#)

From: Msimango Philani (KBY) [<mailto:MsimangoP@dws.gov.za>]
Sent: 16 November 2018 9:58 AM
To: Savannah Public Process <publicprocess@savannahsa.com>
Cc: nicolene@savannahsa.com
Subject: RE: Reminder: Hyperion Solar Notification of Availability of Scoping Report for public review

Good Day

I do not recall receiving the initial email and I have no record of this email.

Can you please verify with your records if indeed I did receive the initial email? Please send that verification to me so I can follow up with our IT Department as I have no records of this.

Also please forward the hardcopy or cd of the impact assessment so it can be sent to an assessor to assess.

The address is as follows:

28 Central Road

Beaconsfield

Kimberley

8301

Attention: Water Quality Management

Regards

Mr. Philani P. Msimango
BSc - Geological Sciences (UKZN); **BSc Hons - Geohydrology** (UFS-IGS)
Control Scientific Technician
Water Quality Management - Lower Vaal
Northern Cape Provincial Operations
E: msimangop@dws.gov.za
T: +27 53 836 7649

Private Bag X6101 | 28 Central Road | Beaconsfield | Kimberley | 8301

"The man that once did sell the lion's skin, While the beast lived was killed with hunting him" - William Shakespeare

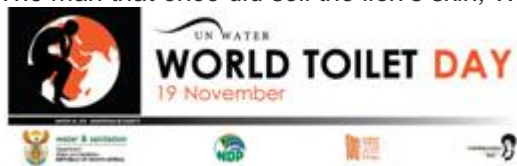

From: Savannah Public Process [<mailto:publicprocess@savannahsa.com>]
Sent: Friday, November 16, 2018 9:47 AM
Cc: nicolene@savannahsa.com
Subject: Reminder: Hyperion Solar Notification of Availability of Scoping Report for public review

Dear Stakeholder,

With reference to the attached notification letter and email below, this email serves as a reminder that the comment period ends on **Monday, 26 November 2018**.

Kindly submit your comments on or before **Monday, 26 November 2018** by close of business.

Thank you and kind regards,

Rozanne Els

Public Participation Co-ordinator | Savannah Environmental (Pty) Ltd
Tel: +27 (0)11 656 3237 | Fax: +27 (0)86 684 0547

SAWEA Award for Leading Environmental Consultant for Wind Projects in 2013 & 2015

> From: Savannah Public Process <publicprocess@savannahsa.com>
> Date Sent: 26/10/2018 13:13
> To:
> Cc:
> Subject: FW: Hyperion Solar Notification of Availability of Scoping Report for public review
>

Dear Stakeholder,

The development of four (4) separate photovoltaic (PV) solar energy facilities (SEFs) as well as associated infrastructure are being proposed on the Remaining Extent of the Farm Lyndoch 432 situated ~16km north of Kathu in the Northern Cape Province. The proposed SEFs fall within the jurisdiction of the Gamagara Local Municipality and within the greater John Taolo Gaetsewe District Municipality. These facilities will be called Hyperion Solar Development 1, 2, 3 and 4.

As a registered Interested and Affected Party (I&AP), you are hereby notified that the Scoping Report is available for review and comment. The report can be viewed at the Kathu Public Library (1 Hendrik van Eck Road, Kathu, Northern Cape Province) from **Friday, 26 October 2018 to Monday, 26 November 2018**. The report can also be downloaded from the following website: www.savannahsa.com. A password to access the downloads page can be requested from the contact person below.

Please refer to the attached notification letter for further information.

Kind regards,

Rozanne Els

Public Participation Co-ordinator | Savannah Environmental (Pty) Ltd
Tel: +27 (0)11 656 3237 | Fax: +27 (0)86 684 0547

SAWEA Award for Leading Environmental Consultant for Wind Projects in 2013 & 2015

DISCLAIMER: This message and any attachments are confidential and intended solely for the addressee. If you have received this message in error, please notify the system manager/sender. Any unauthorized use, alteration or dissemination is prohibited. The Department of Water and Sanitation further accepts no liability whatsoever for any loss, whether it be direct, indirect or consequential, arising from this e-mail, nor for any consequence of its use or storage.

DISCLAIMER: This message and any attachments are confidential and intended solely for the addressee. If you have received this message in error, please notify the system manager/sender. Any unauthorized use, alteration or dissemination is prohibited. The Department of Water and Sanitation further accepts no liability whatsoever for any loss, whether it be direct, indirect or consequential, arising from this e-mail, nor for any consequence of its use or storage.



Virus-free. www.avast.com

DISCLAIMER: This message and any attachments are confidential and intended solely for the addressee. If you have received this message in error, please notify the system manager/sender. Any unauthorized use, alteration or dissemination is prohibited. The Department of Water and Sanitation further accepts no liability whatsoever for any loss, whether it be direct, indirect or consequential, arising from this e-mail, nor for any consequence of its use or storage.

Rozanne Els

From: Savannah Public Process <publicprocess@savannahsa.com>
Sent: 19 November 2018 2:16 PM
To: Mr. Moses Mahunonyane
Cc: shaun@savannahsa.com; rozanne@savannahsa.com
Subject: Hyperion 1, 2, 3 & 4 Solar PVs: Follow-up on comments on Scoping Report
Attachments: Hyperion Solar PVs-SRs AvailabilityNotificationLetter.pdf; Hyperion PVs SR Notification e-mail.pdf

Dear Mr Mahunoyane,

Mr Abe Abrahams directed me to you regarding the proposed four (4) Hyperion Solar PVs located near Kathu (Lower Vaal Catchment Area), Northern Cape Province.

The hard copies of the Scoping Reports were addressed to Mr Abrahams, as informed, and it is believed that your Registry receive these Reports and allocate it to the relevant Case Officer.

I would be appreciated if you can confirm whether you are the Case Officer for this proposed projects and who will be commenting on the Scoping Reports.

We are looking forward to hear from you.

Kind regards,

Nicolene Venter

Public Participation and Social Consultant | Savannah Environmental (Pty) Ltd
Tel: +27 (0)11 656 3237 | Fax: +27 (0)86 684 0547

SAWEA Award for Leading Environmental Consultant for Wind Projects in 2013 & 2015

HYPERION SOLAR PVs: Comment period on Scoping Reports

Search

Forward

Assigned to: Savannah Public Process	Date Sent: 26/11/2018 09:18
Teams: Global	Contacts: Henning Myburgh
From: Savannah Public Process <publicprocess@savannahsa.com>	
To: Mr. Henning Myburgh <henning@agrink.co.za>	
Cc: nicolene@savannahsa.com, shaun@savannahsa.com	
Bcc:	
Subject: HYPERION SOLAR PVs: Comment period on Scoping Reports	
<p>Body:</p> <p>Dear Henning,</p> <p>Thank you for your e-mail and telephone call this morning.</p> <p>Agri Northern Cape's request for extension on the Scoping Reports (SRs) (four proposed Solar Pv developments) has been discussed with the Project Manager and we can confirm that Agri Northern Cape has until Friday, 30 November 2018 to submit written comments.</p> <p>Should Agri Northern Cape not receive any other comments from your members on these four (4) SRs, we kindly request that it please be stated formally either in an e-mail or letter.</p> <p>Please do not hesitate to contact us should you require any additional information at this stage.</p> <p>Kind regards,</p> <p>Nicolene Venter</p> <p>Public Participation and Social Consultant Savannah Environmental (Pty) Ltd Tel: +27 (0)11 656 3237 Fax: +27 (0)86 684 0547</p> <p><i>SAWEA Award for Leading Environmental Consultant for Wind Projects in 2013 & 2015</i></p> <p><input type="checkbox"/> Show Plain Text</p>	
Attachments:	

 Activities

 (0 - 0 of 0)

Search

Attachments

(0 - 0 of 0)		
Subject	Contact	Last Modified
No Data		

Accounts

(0 - 0 of 0)		
Account Name	Town/City	Phone
No Data		

Contacts

(1 - 1 of 1)		
Name	Organisation	Email
Mr. Henning Myburgh	AgriSa Northern Cape	henning@agrink.co.za
		edit

Email Stakeholders

(1 - 4 of 4)		
Name	Organisation	Email
Nicol Jansen	AgriSa Northern Cape	henning@agrink.co.za
Henning Myburgh	AgriSa Northern Cape	henning@agrink.co.za
Shaun Taylor	Savannah Environmental	shaun@savannahsa.com
Nicolene Venter		nicolene@savannahsa.com
		edit

Users

(0 - 0 of 0)			
Name	User Name	Email	Phone
No Data			

Projects

(0 - 0 of 0)			
Name	Assigned To	Start Date:	End Date:

Savannah Environmental Public Process

From: John Geeringh <GeerinJH@eskom.co.za>
Sent: 06 November 2018 9:07 AM
To: Savannah Environmental Public Process
Subject: FW: Hyperion SEF 1-4
Attachments: Eskom requirements for work in or near Eskom servitudes SOLAR (3).doc; Renewable Energy Generation Plant Setbacks to Eskom Infrastructure - Signed.pdf

Just in case?
John



From: John Geeringh
Sent: 01 November 2018 09:36 AM
To: Nicolene Venter (nicolene@savannahsa.com)
Subject: Hyperion SEF 1-4

Please find attached Eskom requirements for works at or near Eskom infrastructure and servitudes. Please send me KMZ files of the affected properties and proposed layouts. Please send me the DEA reference numbers as soon as they become available.

Kind regards

John Geeringh (Pr Sci Nat)
Senior Consultant Environmental Management
Group Capital Division: Land Development and Management
Megawatt Park, D1Y42, Maxwell Drive, Sunninghill, Sandton.
P O Box 1091, Johannesburg, 2000.
Tel: 011 516 7233
Cell: 083 632 7663
Fax: 086 661 4064
E-mail: john.geeringh@eskom.co.za

NB: This Email and its contents are subject to the Eskom Holdings SOC Ltd EMAIL LEGAL NOTICE which can be viewed at http://www.eskom.co.za/Pages/Email_Legal_Spam_Disclaimer.aspx

Eskom requirements for work in or near Eskom servitudes.

1. Eskom's rights and services must be acknowledged and respected at all times.
2. Eskom shall at all times retain unobstructed access to and egress from its servitudes.
3. Eskom's consent does not relieve the developer from obtaining the necessary statutory, land owner or municipal approvals.
4. Any cost incurred by Eskom as a result of non-compliance to any relevant environmental legislation will be charged to the developer.
5. If Eskom has to incur any expenditure in order to comply with statutory clearances or other regulations as a result of the developer's activities or because of the presence of his equipment or installation within the servitude restriction area, the developer shall pay such costs to Eskom on demand.
6. The use of explosives of any type within 500 metres of Eskom's services shall only occur with Eskom's previous written permission. If such permission is granted the developer must give at least fourteen working days prior notice of the commencement of blasting. This allows time for arrangements to be made for supervision and/or precautionary instructions to be issued in terms of the blasting process. It is advisable to make application separately in this regard.
7. Changes in ground level may not infringe statutory ground to conductor clearances or statutory visibility clearances. After any changes in ground level, the surface shall be rehabilitated and stabilised so as to prevent erosion. The measures taken shall be to Eskom's satisfaction.
8. Eskom shall not be liable for the death of or injury to any person or for the loss of or damage to any property whether as a result of the encroachment or of the use of the servitude area by the developer, his/her agent, contractors, employees, successors in title, and assignees. The developer indemnifies Eskom against loss, claims or damages including claims pertaining to consequential damages by third parties and whether as a result of damage to or interruption of or interference with Eskom's services or apparatus or otherwise. Eskom will not be held responsible for damage to the developer's equipment.
9. No mechanical equipment, including mechanical excavators or high lifting machinery, shall be used in the vicinity of Eskom's apparatus and/or services, without prior written permission having been granted by Eskom. If such permission is granted the developer must give at least seven working days' notice prior to the commencement of work. This allows time for arrangements to be made for supervision and/or precautionary instructions to be issued by the relevant Eskom Manager

Note: Where and electrical outage is required, at least fourteen work days are required to arrange it.

10. Eskom's rights and duties in the servitude shall be accepted as having prior right at all times and shall not be obstructed or interfered with.
11. Under no circumstances shall rubble, earth or other material be dumped within the servitude restriction area. The developer shall maintain the area concerned to Eskom's satisfaction. The developer shall be liable to Eskom for the cost of any remedial action which has to be carried out by Eskom.
12. The clearances between Eskom's live electrical equipment and the proposed construction work shall be observed as stipulated by *Regulation 15 of the Electrical Machinery Regulations of the Occupational Health and Safety Act, 1993 (Act 85 of 1993)*.
13. Equipment shall be regarded electrically live and therefore dangerous at all times.
14. In spite of the restrictions stipulated by Regulation 15 of the Electrical Machinery Regulations of the Occupational Health and Safety Act, 1993 (Act 85 of 1993), as an additional safety precaution, Eskom will not approve the erection of houses, or structures occupied or frequented by human beings, under the power lines or within the servitude restriction area.
15. Eskom may stipulate any additional requirements to highlight any possible exposure to Customers or Public to coming into contact or be exposed to any dangers of Eskom plant.
16. It is required of the developer to familiarise himself with all safety hazards related to Electrical plant.
17. Any third party servitudes encroaching on Eskom servitudes shall be registered against Eskom's title deed at the developer's own cost. If such a servitude is brought into being, its existence should be endorsed on the Eskom servitude deed concerned, while the third party's servitude deed must also include the rights of the affected Eskom servitude.

John Geeringh (Pr Sci Nat)

Senior Consultant Environmental Management
Eskom GC: Land Development

	<p style="text-align: center;">SCOT</p>	<p style="text-align: center;">Technology</p>
---	--	--

Title: **Renewable Energy Generation Plant Setbacks to Eskom Infrastructure** Unique Identifier: **240-65559775**

Alternative Reference Number: **N/A**

Area of Applicability: **Power Line Engineering**

Documentation Type: **Guideline**

Revision: **0**

Total Pages: **8**

Next Review Date: **N/A**

Disclosure Classification: **CONTROLLED DISCLOSURE**

Compiled by



J W Chetty
Mechanical Engineer

Date: 20/02/2014

Approved by



V Naidoo
Chief Engineer (Lines)

Date: 24/02/2014

Authorised by

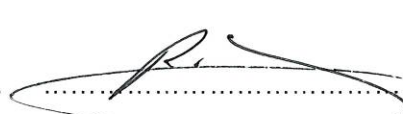

R A Vajeth
Acting Snr Manager (Lines)

Date: 27/2/2014

Supported by SCOT/SC



R Vajeth
SCOT/SC/ Chairperson

Date: 27/2/2014

PCM Reference: 240-65132732 **LINE ENGINEERING SERVICES**

SCOT Study Committee Number/Name : **OVERHEAD LINES**

CONTENTS

	Page
EXECUTIVE SUMMARY	3
1. INTRODUCTION.....	4
2. SUPPORTING CLAUSES	4
2.1 SCOPE	4
2.1.1 Purpose.....	4
2.1.2 Applicability	5
2.2 NORMATIVE/INFORMATIVE REFERENCES	5
2.2.1 Normative.....	5
2.2.2 Informative	5
2.3 DEFINITIONS	5
2.3.1 Disclosure Classification.....	6
2.4 ABBREVIATIONS	6
2.5 ROLES AND RESPONSIBILITIES	6
2.6 PROCESS FOR MONITORING	6
2.7 RELATED/SUPPORTING DOCUMENTS	6
3. DOCUMENT CONTENT	6
3.1 INTERNATIONAL SETBACK COMPARISON	6
3.2 ESKOM APPROACH FOR WIND FARMS.....	7
4. AUTHORISATION	8
5. REVISIONS.....	8
6. DEVELOPMENT TEAM	9

FIGURES

Figure 1: Horizontal Axis Wind Turbine	8
--	---

CONTROLLED DISCLOSURE

When downloaded from the EDMS, this document is uncontrolled and the responsibility rests with the user to ensure it is in line with the authorised version on the system.

EXECUTIVE SUMMARY

In recent decades, the use of wind turbines, concentrated solar plants and photovoltaic plants have been on the increase as it serves as an abundant source of energy. This document specifies setbacks for wind turbines and the reasons for these setbacks from infrastructure as well as setbacks for concentrated solar plants and photovoltaic plants. Setbacks for wind turbines employed in other countries were compared and a general setback to be used by Eskom was suggested for use with wind turbines and other renewable energy generation plants.

CONTROLLED DISCLOSURE

When downloaded from the EDMS, this document is uncontrolled and the responsibility rests with the user to ensure it is in line with the authorised version on the system.

1. INTRODUCTION

During the last few decades, a large amount of wind turbines have been installed in wind farms to accommodate for the large demand of energy and depleting fossil fuels. Wind is one of the most abundant sources of renewable energy. Wind turbines harness the energy of this renewable resource for integration in electricity networks. The extraction of wind energy is its primary function and thus the aerodynamics of the wind turbine is important. There are many different types of wind turbines which will all exhibit different wind flow characteristics. The most common wind turbine used commercially is the Horizontal Axis Wind Turbine. Wind flow characteristics of this turbine are important to analyse as it may have an effect on surrounding infrastructure.

Wind turbines also cause large turbulence downwind that may affect existing infrastructure. Debris or parts of the turbine blade, in the case of a failure, may be tossed behind the turbine and may lead to damage of infrastructure in the wake path.

This document outlines the minimum distances that need to be introduced between a wind turbine and Eskom infrastructure to ensure that debris and / or turbulence would not negatively impact on the infrastructure.

Safety distances of wind turbines from other structures as implemented by other countries were also considered and the reasons for their selection were noted.

Concentrated solar plants and photovoltaic plants setbacks away from substations were also to be considered to prevent restricting possible power line access routes to the substation.

2. SUPPORTING CLAUSES

2.1 SCOPE

This document provides guidance on the safe distance that a wind turbine should be located from any Eskom power line or substation. The document specifies setback distances for transmission lines (220 kV to 765 kV), distribution lines (6.6 kV to 132 kV) and all Eskom substations. Setbacks for concentrated solar plants and photovoltaic plants are also specified away from substations.

2.1.1 Purpose

Setbacks for wind turbines and power lines / substations are required for various reasons. These include possible catastrophic failure of the turbine blade that may release fragments and which may be thrown onto nearby power lines that may result in damage with associated unplanned outages. Turbulence behind the turbine may affect helicopter flight during routine Eskom live line maintenance and

CONTROLLED DISCLOSURE

When downloaded from the EDMS, this document is uncontrolled and the responsibility rests with the user to ensure it is in line with the authorised version on the system.

inspections that may lead to safety risk of the aircraft / personnel. Concentrated solar plants and photovoltaic plants setback away from substations were required to prevent substations from being boxed in by these renewable generation plants limiting line route access to the substations.

2.1.2 Applicability

This document is applicable to the siting of all new and existing wind turbines, concentrated solar plants and photovoltaic plants near power lines and substations.

2.2 NORMATIVE/INFORMATIVE REFERENCES

2.2.1 Normative

1. <http://www.envir.ee/orb.aw/class=file/action=preview/id=1170403/Hiiumaa+turbulence+impact+EMD.pdf>.
2. <http://www.energy.ca.gov/2005publications/CEC-500-2005-184/CEC-500-2005-184.PDF>
3. <http://www.adamscountywind.com/Revised%20Site/Windmills/Adams%20County%20Ordinance/Adams%20County%20Wind%20Ord.htm>
4. http://www.dsireusa.org/incentives/incentive.cfm?Incentive_Code=PA11R&RE=1&EE=1
5. <http://www.wind-watch.org/documents/european-setbacks-minimum-distance-between-wind-turbines-and-habitations/>
6. <http://www.publications.parliament.uk/pa/ld201011/ldbills/017/11017.1-i.html>
7. http://www.caw.ca/assets/pdf/Turbine_Safety_Report.pdf
8. Rogers J, Slegers N, Costello M. (2011) A method for defining wind turbine setback standards. Wind energy 10.1002/we.468

2.2.2 Informative

None

2.3 DEFINITIONS

Definition	Description
Setback	The minimum distance between a wind turbine and boundary line/dwelling/road/infrastructure/servitude etc.
Flicker	Effect caused when rotating wind turbine blades periodically cast shadows
Tip Height	The total height of the wind turbine ie. Hub height plus half rotor diameter (see Figure1)

CONTROLLED DISCLOSURE

When downloaded from the EDMS, this document is uncontrolled and the responsibility rests with the user to ensure it is in line with the authorised version on the system.

2.3.1 Disclosure Classification

Controlled disclosure: controlled disclosure to external parties (either enforced by law, or discretionary).

2.4 ABBREVIATIONS

Abbreviation	Description
None	

2.5 ROLES AND RESPONSIBILITIES

All personnel involved in the positioning wind turbines, concentrated solar plants and photovoltaic plants near power lines/substations must follow the setbacks outlined in this guideline.

2.6 PROCESS FOR MONITORING

Approval by Eskom in writing.

2.7 RELATED/SUPPORTING DOCUMENTS

None

3. DOCUMENT CONTENT

3.1 INTERNATIONAL SETBACK COMPARISON

Wind Turbine setbacks employed by various countries were considered. It was found that setbacks were determined for various reasons that include noise, flicker, turbine blade failure and wind effects. The distances (setbacks) varied based on these factors and were influenced by the type of infrastructure

Wind turbine setbacks varied for roads, power lines, dwellings, buildings and property and it was noted that the largest setbacks were employed for reasons of noise and flicker related issues [1-7]. Very few countries specified setbacks for power lines.

The literature survey [1-7], yielded information about studies and experiments were conducted to determine the distance that a broken fragment from a wind turbine might be thrown. Even though of low probability of hitting a power line [5.0×10^{-5}]^[8], the distances recorded were significant [750m]^[8]

Setbacks were thus introduced to prevent any damage to Eskom infrastructure.

CONTROLLED DISCLOSURE

When downloaded from the EDMS, this document is uncontrolled and the responsibility rests with the user to ensure it is in line with the authorised version on the system.

Wind turbines may also cause changes in wind patterns with turbulent effects behind the hub. These factors dictate the wind turbine setbacks specified in this document.

Concentrated solar plants and photovoltaic plants also can limit access into the substation for power lines of all voltages. A setback distance must therefore be employed to prevent the substation from being boxed in by these generation plants. These setback distances are specified in this document.

3.2 ESKOM REQUIRED SETBACKS

- Eskom requires a setback distance of 3 times the tip height of the wind turbine from the edge of the closest Eskom servitude (including vacant servitudes) for transmission lines.
- Eskom requires a setback distance of 1 times the tip height of the wind turbine from the edge of the closest Eskom servitude (including vacant servitudes) for distribution Lines.
- Eskom must be informed of any proposed wind turbine, concentrated solar plants and photovoltaic activity within a 5 km radius of a substation. No wind turbine structure shall be built within a 2 km radius of the closest point of the substation. Where concentrated solar plants and photovoltaic structures fall within a 2 km radius of the closest point of a substation, Eskom should be informed in writing during the planning phase of the construction of such plant or structure.
- Applicants must show that Eskom radio telecommunication systems (mainly microwave systems) will not be affected in any way by wind turbines.

CONTROLLED DISCLOSURE

When downloaded from the EDMS, this document is uncontrolled and the responsibility rests with the user to ensure it is in line with the authorised version on the system.

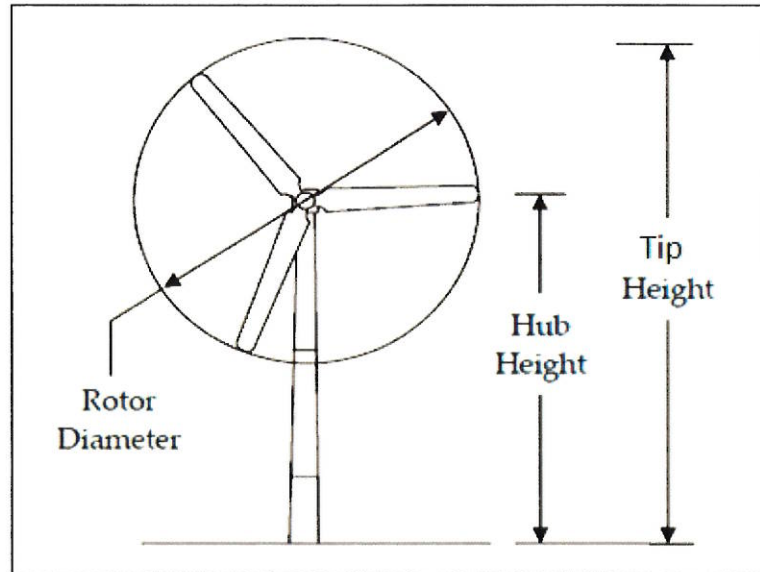

Figure 1: Horizontal Axis Wind Turbine ^[2]

4. AUTHORISATION

This document has been seen and accepted by:

Name & Surname	Designation
V Naidoo	Chief Engineer
Dr P H Pretorius	Electrical Specialist
J Geeringh	Snr Consultant Environ Mngt
B Haridass	Snr Consultant Engineer
R A Vajeth	Acting Snr Manager (Lines)

5. REVISIONS

Date	Rev.	Compiler	Remarks
November 2013	0	J W Chetty	First Publication - No renewable energy generation plant setback specification in existence

CONTROLLED DISCLOSURE

When downloaded from the EDMS, this document is uncontrolled and the responsibility rests with the user to ensure it is in line with the authorised version on the system.

6. DEVELOPMENT TEAM

The following people were involved in the development of this document:

Jonathan W Chetty (Mechanical Engineer)

Vivendhra Naidoo (Chief Engineer)

Dr Pieter H Pretorius (Electrical Specialist)

John Geeringh (Snr Consultant Environ Mngt)

Bharat Haridass (Snr Consultant Engineer)

Riaz A Vajeth (Acting Snr Manager (Lines))

CONTROLLED DISCLOSURE

When downloaded from the EDMS, this document is uncontrolled and the responsibility rests with the user to ensure it is in line with the authorised version on the system.

ATTEMPTS TO ATTAIN COMMENTS

Savannah Environmental Public Process

From: Savannah Environmental Public Process <publicprocess@savannahsa.com>
Sent: 21 November 2018 7:38 AM
To: 'henning@agrink.co.za'
Subject: Request for Comment - Hyperion Solar Development
Attachments: Hyperion Solar PVs-SRs AvailabilityNotificationLetter.pdf

Importance: High

Dear Nicol,

With reference to the attached notification letter in regards to the Hyperion Solar Development projects, we noted that we have not yet received written comment on the Scoping Report for public review from AgriSa.

This e-mail serves as a reminder that the comment period for the above mentioned project ends on **Monday, 26 November 2018.**

It would be appreciated if you can submit written comment before or on **Monday, 26 November 2018** by close of business.

Should you not have any comments, please inform us accordingly.

Kind regards,

Savannah Environmental Public Process

From: Savannah Environmental Public Process <publicprocess@savannahsa.com>
Sent: 21 November 2018 7:39 AM
To: 'Simphiwe Masilela'
Subject: Request for Comment - Hyperion Solar Development
Attachments: Hyperion Solar PVs-SRs AvailabilityNotificationLetter.pdf

Importance: High

Dear Simphiwe,

With reference to the attached notification letter in regards to the Hyperion Solar Development projects, we noted that we have not yet received written comment on the Scoping Report for public review from ANTS.

This e-mail serves as a reminder that the comment period for the above mentioned project ends on **Monday, 26 November 2018.**

It would be appreciated if you can submit written comment before or on **Monday, 26 November 2018** by close of business.

Should you not have any comments, please inform us accordingly.

Kind regards,

Savannah Environmental Public Process

From: Savannah Environmental Public Process <publicprocess@savannahsa.com>
Sent: 21 November 2018 7:04 AM
To: 'jacolinema@daff.gov.za'
Subject: Request for Comment - Hyperion Solar Development
Attachments: Hyperion Solar PVs-SRs AvailabilityNotificationLetter.pdf

Importance: High

Dear Jacoline,

With reference to the attached notification letter in regards to the Hyperion Solar Development projects, we noted that we have not yet received written comment on the Scoping Report for public review from the Department of Agriculture, Forestry and Fisheries.

This e-mail serves as a reminder that the comment period for the above mentioned project ends on **Monday, 26 November 2018.**

It would be appreciated if you can submit written comment before or on **Monday, 26 November 2018** by close of business.

Should you not have any comments, please inform us accordingly.

Kind regards,

Savannah Environmental Public Process

From: Savannah Environmental Public Process <publicprocess@savannahsa.com>
Sent: 21 November 2018 7:01 AM
To: 'thokob@daff.gov.za'; 'mashuduma@daff.gov.za'
Subject: Request for Comment - Hyperion Solar Development
Attachments: Hyperion Solar PVs-SRs AvailabilityNotificationLetter.pdf

Importance: High

Dear Thoko and Mashudu,

With reference to the attached notification letter in regards to the Hyperion Solar Development projects, we noted that we have not yet received written comment on the Scoping Report for public review from the Department of Agriculture, Forestry and Fisheries.

This e-mail serves as a reminder that the comment period for the above mentioned project ends on **Monday, 26 November 2018.**

It would be appreciated if you can submit written comment before or on **Monday, 26 November 2018** by close of business.

Should you not have any comments, please inform us accordingly.

Kind regards,

Savannah Environmental Public Process

From: Savannah Environmental Public Process <publicprocess@savannahsa.com>
Sent: 21 November 2018 7:22 AM
To: 'Stanley Tshitwamulomoni'
Subject: Request for Comment - Hyperion Solar Development
Attachments: Hyperion Solar PVs-SRs AvailabilityNotificationLetter.pdf

Importance: High

Dear Stanley,

With reference to the attached notification letter in regards to the Hyperion Solar Development projects, we noted that we have not yet received written comment on the Scoping Report for public review from the Department of Environmental Affairs: Biodiversity.

This was the last project submitted to DEA: Biodiversity for attention to Wilma Lutch. With reference to my email confirming that you are the relevant person, we will make sure to address all future projects to you.

This e-mail serves as a reminder that the comment period for the above mentioned project ends on **Monday, 26 November 2018.**

It would be appreciated if you can submit written comment before or on **Monday, 26 November 2018** by close of business.

Should you not have any comments, please inform us accordingly.

Kind regards,

Rozanne Els

From: Shaun Taylor <shaun@savannahsa.com>
Sent: 04 December 2018 3:29 PM
To: JMpelane@environment.gov.za
Cc: 'Nicolene Venter'; 'Jo-Anne Thomas'; thalita@savannahsa.com; 'Rozanne Els'
Subject: RE: DEA Comments Hyperion Solar Development 4 Ref: 14/12/16/3/3/2/1112

Importance: High

Dear Jay-Jay

This email serves to follow up on the request below for comments on this project (Hyperion Solar Development 4 Ref: 14/12/16/3/3/2/1112).

We wish to submit the FSR, but require your comments before we can finalise.

Regards

Shaun Taylor

Environmental and Permitting Lead Consultant | Savannah Environmental (Pty) Ltd
Tel: +27 (0)11 656 3237 | Cell: +27(0)72 779 4899 | Fax: +27 (0)86 684 0547

[SAWEA Award for Leading Environmental Consultant for Wind Projects in 2013 & 2015](#)

From: Shaun Taylor <shaun@savannahsa.com>
Sent: Thursday, 29 November 2018 13:46
To: 'JMpelane@environment.gov.za' <JMpelane@environment.gov.za>
Cc: 'Nicolene Venter' <nicolene@savannahsa.com>; 'Jo-Anne Thomas' <joanne@savannahsa.com>; 'thalita@savannahsa.com' <thalita@savannahsa.com>; 'Rozanne Els' <rozanne@savannahsa.com>
Subject: DEA Comments Hyperion Solar Development 4 Ref: 14/12/16/3/3/2/1112
Importance: High

Dear Jay-Jay

Please note that we are awaiting comments from the Department for project reference: 14/12/16/3/3/2/1112 (Hyperion Solar Development 4) from the Department. Importantly, note that the comment period has ended as of 26 November 2018.

We have checked with EIA admin who have referred us to you as the case officer.

Kindly advise when these can be received.

We look forward to your soonest response.

Regards

Rozanne Els

From: Shaun Taylor <shaun@savannahsa.com>
Sent: 06 December 2018 11:50 AM
To: JMpelane@environment.gov.za
Cc: 'Nicolene Venter'; 'Jo-Anne Thomas'; thalita@savannahsa.com; 'Rozanne Els'
Subject: RE: DEA Comments Hyperion Solar Development 4 Ref: 14/12/16/3/3/2/1112

Hi Jay-jay

Thank you for taking my call today.

As per our discussion, given that the comments will only follow through in the EIA phase, should the plan of study be approved, we will finalise the Scoping Report for submission to DEA for decision making.

Regards

Shaun Taylor

Environmental and Permitting Lead Consultant | Savannah Environmental (Pty) Ltd
Tel: +27 (0)11 656 3237 | Cell: +27(0)72 779 4899 | Fax: +27 (0)86 684 0547

[SAWEA Award for Leading Environmental Consultant for Wind Projects in 2013 & 2015](#)

From: Shaun Taylor <shaun@savannahsa.com>
Sent: Tuesday, 04 December 2018 15:29
To: 'JMpelane@environment.gov.za' <JMpelane@environment.gov.za>
Cc: 'Nicolene Venter' <nicolene@savannahsa.com>; 'Jo-Anne Thomas' <joanne@savannahsa.com>; 'thalita@savannahsa.com' <thalita@savannahsa.com>; 'Rozanne Els' <rozanne@savannahsa.com>
Subject: RE: DEA Comments Hyperion Solar Development 4 Ref: 14/12/16/3/3/2/1112
Importance: High

Dear Jay-Jay

This email serves to follow up on the request below for comments on this project (Hyperion Solar Development 4 Ref: 14/12/16/3/3/2/1112).

We wish to submit the FSR, but require your comments before we can finalise.

Regards

Shaun Taylor

Environmental and Permitting Lead Consultant | Savannah Environmental (Pty) Ltd
Tel: +27 (0)11 656 3237 | Cell: +27(0)72 779 4899 | Fax: +27 (0)86 684 0547

[SAWEA Award for Leading Environmental Consultant for Wind Projects in 2013 & 2015](#)

From: Shaun Taylor <shaun@savannahsa.com>
Sent: Thursday, 29 November 2018 13:46
To: 'JMpelane@environment.gov.za' <JMpelane@environment.gov.za>
Cc: 'Nicolene Venter' <nicolene@savannahsa.com>; 'Jo-Anne Thomas' <joanne@savannahsa.com>; 'thalita@savannahsa.com' <thalita@savannahsa.com>; 'Rozanne Els' <rozanne@savannahsa.com>
Subject: DEA Comments Hyperion Solar Development 4 Ref: 14/12/16/3/3/2/1112
Importance: High

Dear Jay-Jay

Please note that we are awaiting comments from the Department for project reference: 14/12/16/3/3/2/1112 (Hyperion Solar Development 4) from the Department. Importantly, note that the comment period has ended as of 26 November 2018.

We have checked with EIA admin who have referred us to you as the case officer.

Kindly advise when these can be received.

We look forward to your soonest response.

Regards

Savannah Environmental Public Process

From: Savannah Environmental Public Process <publicprocess@savannahsa.com>
Sent: 21 November 2018 7:17 AM
To: 'sdelafontaine@gmail.com'
Subject: Request for Comment - Hyperion Solar Development
Attachments: Hyperion Solar PVs-SRs AvailabilityNotificationLetter.pdf

Importance: High

Dear Samantha,

With reference to the attached notification letter in regards to the Hyperion Solar Development projects, we noted that we have not yet received written comment on the Scoping Report for public review from the Department of Environmental and Nature Conservation: Northern Cape

This e-mail serves as a reminder that the comment period for the above mentioned project ends on **Monday, 26 November 2018.**

It would be appreciated if you can submit written comment before or on **Monday, 26 November 2018** by close of business.

Should you not have any comments, please inform us accordingly.

Kind regards,

Savannah Environmental Public Process

From: Savannah Environmental Public Process <publicprocess@savannahsa.com>
Sent: 21 November 2018 7:29 AM
To: 'BFisher@ncpg.gov.za'
Subject: Request for Comment - Hyperion Solar Development
Attachments: Hyperion Solar PVs-SRs AvailabilityNotificationLetter.pdf

Importance: High

Dear Bryan,

With reference to the attached notification letter in regards to the Hyperion Solar Development projects, we noted that we have not yet received written comment on the Scoping Report for public review from the Northern Cape Department of Environment and Nature Conservation.

This e-mail serves as a reminder that the comment period for the above mentioned project ends on **Monday, 26 November 2018.**

It would be appreciated if you can submit written comment before or on **Monday, 26 November 2018** by close of business.

Should you not have any comments, please inform us accordingly.

Kind regards,

Savannah Environmental Public Process

From: Savannah Environmental Public Process <publicprocess@savannahsa.com>
Sent: 21 November 2018 7:06 AM
To: 'Pheladi.Masipa@energy.gov.za'
Subject: Request for Comment - Hyperion Solar Development
Attachments: Hyperion Solar PVs-SRs AvailabilityNotificationLetter.pdf

Importance: High

Dear Pheladi,

With reference to the attached notification letter in regards to the Hyperion Solar Development projects, we noted that we have not yet received written comment on the Scoping Report for public review from the Department of Energy.

This e-mail serves as a reminder that the comment period for the above mentioned project ends on **Monday, 26 November 2018.**

It would be appreciated if you can submit written comment before or on **Monday, 26 November 2018** by close of business.

Should you not have any comments, please inform us accordingly.

Kind regards,

Savannah Environmental Public Process

From: Savannah Environmental Public Process <publicprocess@savannahsa.com>
Sent: 21 November 2018 7:26 AM
To: 'roelofse.j@vodamail.co.za'
Subject: Request for Comment - Hyperion Solar Development
Attachments: Hyperion Solar PVs-SRs AvailabilityNotificationLetter.pdf

Importance: High

Dear Jaco,

With reference to the attached notification letter in regards to the Hyperion Solar Development projects, we noted that we have not yet received written comment on the Scoping Report for public review from the Department of Roads and Public Works.

This e-mail serves as a reminder that the comment period for the above mentioned project ends on **Monday, 26 November 2018.**

It would be appreciated if you can submit written comment before or on **Monday, 26 November 2018** by close of business.

Should you not have any comments, please inform us accordingly.

Kind regards,

Savannah Environmental Public Process

From: Savannah Environmental Public Process <publicprocess@savannahsa.com>
Sent: 21 November 2018 7:28 AM
To: 'franksl@dwa.gov.za'
Cc: 'shibambus@dwa.gov.za'
Subject: Request for Comment - Hyperion Solar Development
Attachments: Hyperion Solar PVs-SRs AvailabilityNotificationLetter.pdf

Importance: High

Dear Abe,

With reference to the attached notification letter in regards to the Hyperion Solar Development projects, we noted that we have not yet received written comment on the Scoping Report for public review from the Department of Water and Sanitation.

This e-mail serves as a reminder that the comment period for the above mentioned project ends on **Monday, 26 November 2018.**

It would be appreciated if you can submit written comment before or on **Monday, 26 November 2018** by close of business.

Should you not have any comments, please inform us accordingly.

Kind regards,

Rozanne Els

From: Nicolene Venter <nicolene@savannahsa.com>
Sent: 26 November 2018 4:39 PM
To: 'Magonono Fhatuwani Aron (KBY)'; 'Moalosi Kelebogile(KBY)'
Cc: 'Shaun Taylor'; 'Rozanne Els'
Subject: RE: Hyperion Solar PVs 1, 2, 3 & 4: DWS Comments (corrections to follow)

Dear Aron,

Feedback appreciated.

Nicolene Venter

Public Participation & Social Consultant | Savannah Environmental (Pty) Ltd
Tel: +27 (0)11 656 3237 | Fax: +27 (0)86 684 0547

[SAWEA Award for Leading Environmental Consultant for Wind Projects in 2013 & 2015](#)

From: Magonono Fhatuwani Aron (KBY) <MagononoF@dws.gov.za>
Sent: Monday, November 26, 2018 4:24 PM
To: Nicolene Venter <nicolene@savannahsa.com>; Moalosi Kelebogile(KBY) <MoalosiK2@dws.gov.za>
Cc: 'Shaun Taylor' <shaun@savannahsa.com>; 'Rozanne Els' <rozanne@savannahsa.com>
Subject: RE: Hyperion Solar PVs 1, 2, 3 & 4: DWS Comments (corrections to follow)

Some of your applications are with other case officers.

From: Nicolene Venter [mailto:nicolene@savannahsa.com]
Sent: 26 November 2018 04:16 PM
To: Magonono Fhatuwani Aron (KBY); Moalosi Kelebogile(KBY)
Cc: 'Shaun Taylor'; 'Rozanne Els'
Subject: Hyperion Solar PVs 1, 2, 3 & 4: DWS Comments (corrections to follow)

Good Day Aron,

Thank you for the updated information below.

We await the updated signed letters for the four (4) Hyperion Solar PV projects.

Kind regards,

Nicolene Venter

Public Participation & Social Consultant | Savannah Environmental (Pty) Ltd
Tel: +27 (0)11 656 3237 | Fax: +27 (0)86 684 0547

[SAWEA Award for Leading Environmental Consultant for Wind Projects in 2013 & 2015](#)

From: Magonono Fhatuwani Aron (KBY) [mailto:MagononoF@dws.gov.za]
Sent: 26 November 2018 12:17 PM
To: publicprocess@savannahsa.com
Subject: RE: Message from KM_C364e

Good morning Nicolene Venter

Just ignore the letters that were signed on the **21/11/2018**, there was mistakes with the footer. Our admin office did not see that those letters were amended. Therefore the correct letters should have the date of the 26/11/2018.

Hope you will find this in order,

Best regards
Aron

From: Moalosi Kelebogile(KBY)
Sent: 26 November 2018 12:05 PM
To: publicprocess@savannahsa.com
Cc: Magonono Fhatuwani Aron (KBY)
Subject: FW: Message from KM_C364e

Ms. Nicolene Venter,

The attached is for your attention, please note the original will be posted to you.

Warm Regards,

Kelebogile Moalosi
Lower Vaal Catchment (Admin Support)
28 Central Road
Beaconsfield
Kimberley
8301

Tel: 053 836 7606
Email: MoalosiK2@dwa.gov.za

DISCLAIMER: This message and any attachments are confidential and intended solely for the addressee. If you have received this message in error, please notify the system manager/sender. Any unauthorized use, alteration or dissemination is prohibited. The Department of Water and Sanitation further accepts no liability whatsoever for any loss, whether it be direct, indirect or consequential, arising from this e-mail, nor for any consequence of its use or storage.



Virus-free. www.avast.com

DISCLAIMER: This message and any attachments are confidential and intended solely for the addressee. If you have received this message in error, please notify the system manager/sender. Any unauthorized use, alteration or dissemination is prohibited. The Department of Water and Sanitation further accepts no liability whatsoever for any loss, whether it be direct, indirect or consequential, arising from this e-mail, nor for any consequence of its use or storage.

Savannah Environmental Public Process

From: Savannah Environmental Public Process <publicprocess@savannahsa.com>
Sent: 21 November 2018 7:24 AM
To: 'Mmboneni.Mutheiwana@dmr.gov.za'
Subject: Request for Comment - Hyperion Solar Development
Attachments: Hyperion Solar PVs-SRs AvailabilityNotificationLetter.pdf

Importance: High

Dear Kevin,

With reference to the attached notification letter in regards to the Hyperion Solar Development projects, we noted that we have not yet received written comment on the Scoping Report for public review from the Department of Mineral Resources.

This e-mail serves as a reminder that the comment period for the above mentioned project ends on **Monday, 26 November 2018.**

It would be appreciated if you can submit written comment before or on **Monday, 26 November 2018** by close of business.

Should you not have any comments, please inform us accordingly.

Kind regards,

Savannah Environmental Public Process

From: Savannah Environmental Public Process <publicprocess@savannahsa.com>
Sent: 21 November 2018 7:32 AM
To: 'Makgalemele@drdlr.gov.za'
Subject: Request for Comment - Hyperion Solar Development
Attachments: Hyperion Solar PVs-SRs AvailabilityNotificationLetter.pdf

Importance: High

Dear Nozizwe,

With reference to the attached notification letter in regards to the Hyperion Solar Development projects, we noted that we have not yet received written comment on the Scoping Report for public review from the Department of Rural Development and Land Reform.

We have noted that the courier package with the CD for your attention was sent back to us. We could not reach you for comment on the matter.

This e-mail serves as a reminder that the comment period for the above mentioned project ends on **Monday, 26 November 2018.**

It would be appreciated if you can submit written comment before or on **Monday, 26 November 2018** by close of business.

Should you not have any comments, please inform us accordingly.

Kind regards,

Savannah Environmental Public Process

From: Savannah Environmental Public Process <publicprocess@savannahsa.com>
Sent: 21 November 2018 7:35 AM
To: 'clementi@gamagara.gov.za'
Subject: Request for Comment - Hyperion Solar Development
Attachments: Hyperion Solar PVs-SRs AvailabilityNotificationLetter.pdf

Importance: High

Dear Thusoeng ,

With reference to the attached notification letter in regards to the Hyperion Solar Development projects, we noted that we have not yet received written comment on the Scoping Report for public review from the Gamagara Local Municipality.

This e-mail serves as a reminder that the comment period for the above mentioned project ends on **Monday, 26 November 2018.**

It would be appreciated if you can submit written comment before or on **Monday, 26 November 2018** by close of business.

Should you not have any comments, please inform us accordingly.

Kind regards,

Savannah Environmental Public Process

From: Savannah Environmental Public Process <publicprocess@savannahsa.com>
Sent: 21 November 2018 7:34 AM
To: 'dmolaole@taologaetsewe.gov.za'
Subject: Request for Comment - Hyperion Solar Development
Attachments: Hyperion Solar PVs-SRs AvailabilityNotificationLetter.pdf

Importance: High

Dear Disang,

With reference to the attached notification letter in regards to the Hyperion Solar Development projects, we noted that we have not yet received written comment on the Scoping Report for public review from the John Taolo Gaetsewe District Municipality.

This e-mail serves as a reminder that the comment period for the above mentioned project ends on **Monday, 26 November 2018.**

It would be appreciated if you can submit written comment before or on **Monday, 26 November 2018** by close of business.

Should you not have any comments, please inform us accordingly.

Kind regards,

Savannah Environmental Public Process

From: Savannah Environmental Public Process <publicprocess@savannahsa.com>
Sent: 21 November 2018 7:37 AM
To: 'ratha.timothy@gmail.com'
Subject: Request for Comment - Hyperion Solar Development
Attachments: Hyperion Solar PVs-SRs AvailabilityNotificationLetter.pdf

Importance: High

Dear Timothy,

With reference to the attached notification letter in regards to the Hyperion Solar Development projects, we noted that we have not yet received written comment on the Scoping Report for public review from NERSA.

This e-mail serves as a reminder that the comment period for the above mentioned project ends on **Monday, 26 November 2018.**

It would be appreciated if you can submit written comment before or on **Monday, 26 November 2018** by close of business.

Should you not have any comments, please inform us accordingly.

Kind regards,

Savannah Environmental Public Process

From: Savannah Environmental Public Process <publicprocess@savannahsa.com>
Sent: 21 November 2018 7:40 AM
To: 'Abrahamsn@nra.co.za'
Subject: Request for Comment - Hyperion Solar Development
Attachments: Hyperion Solar PVs-SRs AvailabilityNotificationLetter.pdf

Importance: High

Dear Nicole,

With reference to the attached notification letter in regards to the Hyperion Solar Development projects, we noted that we have not yet received written comment on the Scoping Report for public review from SANRAL.

This e-mail serves as a reminder that the comment period for the above mentioned project ends on **Monday, 26 November 2018.**

It would be appreciated if you can submit written comment before or on **Monday, 26 November 2018** by close of business.

Should you not have any comments, please inform us accordingly.

Kind regards,

Savannah Environmental Public Process

From: Savannah Environmental Public Process <publicprocess@savannahsa.com>
Sent: 21 November 2018 7:41 AM
To: 'atiplady@ska.ac.za'
Subject: Request for Comment - Hyperion Solar Development
Attachments: Hyperion Solar PVs-SRs AvailabilityNotificationLetter.pdf

Importance: High

Dear Adrian,

With reference to the attached notification letter in regards to the Hyperion Solar Development projects, we noted that we have not yet received written comment on the Scoping Report for public review from SKA.

This e-mail serves as a reminder that the comment period for the above mentioned project ends on **Monday, 26 November 2018.**

It would be appreciated if you can submit written comment before or on **Monday, 26 November 2018** by close of business.

Should you not have any comments, please inform us accordingly.

Kind regards,

Savannah Environmental Public Process

From: Savannah Environmental Public Process <publicprocess@savannahsa.com>
Sent: 21 November 2018 7:07 AM
To: 'kebasenosi@yahoo.com'
Subject: Request for Comment - Hyperion Solar Development
Attachments: Hyperion Solar PVs-SRs AvailabilityNotificationLetter.pdf

Importance: High

Dear Kebasenosi,

With reference to the attached notification letter in regards to the Hyperion Solar Development projects, we noted that we have not yet received written comment on the Scoping Report for public review from the South African Defence Force.

This e-mail serves as a reminder that the comment period for the above mentioned project ends on **Monday, 26 November 2018.**

It would be appreciated if you can submit written comment before or on **Monday, 26 November 2018** by close of business.

Should you not have any comments, please inform us accordingly.

Kind regards,