

Figure 14-10: Main Road 790

14.4.2.3.3 Access Route Option 3

The main access point for Access Route Option 3, Route A, Route B and Route C (refer to Table 14-2), from a surfaced road is from DR3096, located along Trunk Road 38/02 (R48), approximately 100 km north-east of De Aar. Site observations concluded that Trunk Road 38/02 is in a very bad condition with potholes present along most part of this portion of road. There will also be a large portion of travel distance on gravel roads along this access. This is the least favourable option. Figure 14-11 indicates the sight distance to the left and right along the R48 and a photo of DR3096 taken from the R48.



Figure 14-11: Divisional Road 3096

All routes to the site should however be further investigated to ensure that the abnormal loads are not obstructed at any point by geometric, height and width limitations along the route. The applicable permits to transport the abnormal loads should also be obtained. It should also be ensured that all the gravel haulage roads should be maintained during the construction phase and reinstated after the construction phase is completed, this is applicable for both provincial roads and also the private internal farm roads to an extent as agreed with the landowners.

14.4.3 Project Specific Description

14.4.3.1 *Kudu Solar Facility 7 and associated infrastructure*

Kudu Solar PV facility (PV7) is shown in Figure 14-12. The preferred access route will be from the R48 (TR38/01), along DR3093 and DR3084 gravel roads. Refer to Table 14-2 for additional information.



Figure 14-12: Kudu Solar Facility 7 (PV7)

Furthermore, direct access to the facility will be taken from DR3084 along an existing farm access as shown in Figure 14-13. The development footprint and detailed layout are acceptable as shown in Figure 14-13. Changes to the detailed layouts are deemed acceptable if the changes remain within the approved buildable areas / development footprints and area assessed during the Scoping and EIA Process with no-go sensitive areas avoided.

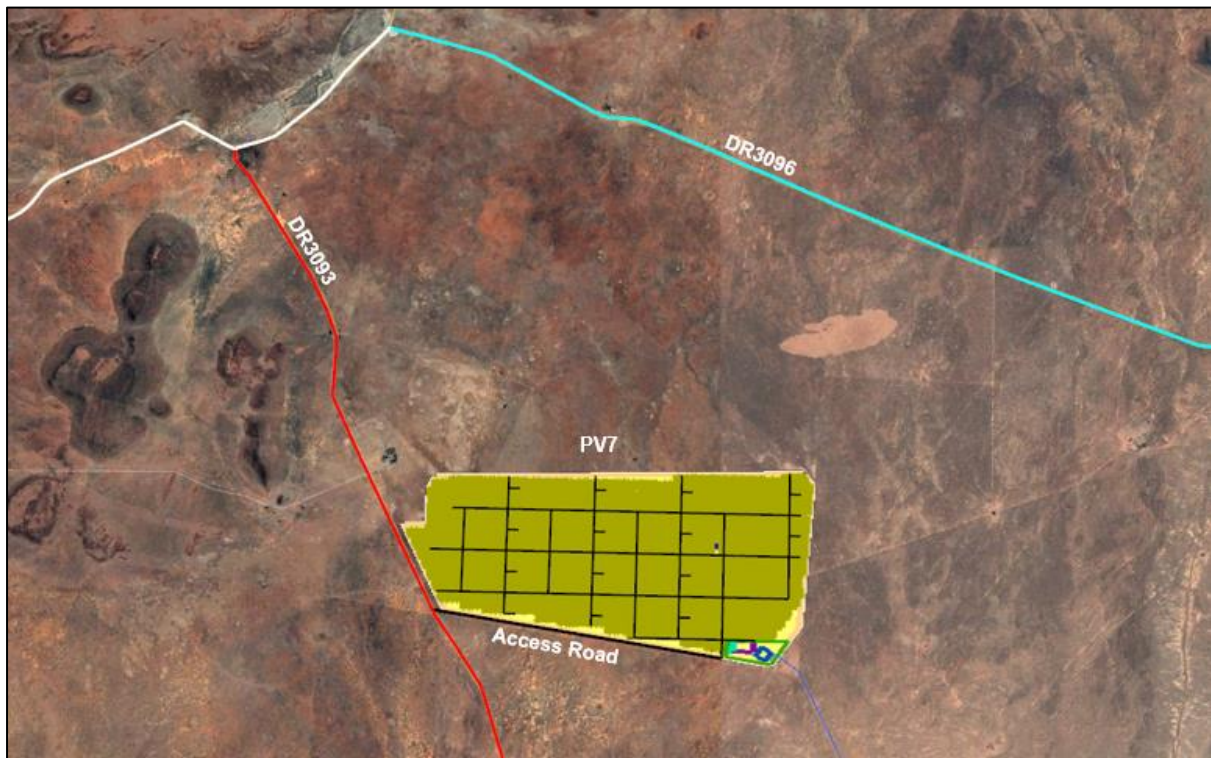

Figure 14-13: Kudu Solar Facility 7 (PV7) Access Location

14.4.4 Identification of Environmental Sensitivities

14.4.4.1 Sensitivities identified by the National Web-Based Environmental Screening Tool

Part of the terms of reference was to identify sensitivities by the National Web-Based Environmental Screening Tool (Screening Tool). However, it is important to note that there are no dedicated traffic or transport related themes on the Screening Tool, therefore the environmental sensitivity of the proposed project area as identified by the Screening Tool is not applicable. Therefore, no site sensitivity verification report is required (as indicated in Appendix C). Furthermore, there is no dedicated assessment protocol prescribed for Traffic. Therefore, the specialist assessment has been undertaken in compliance with Appendix 6 of the NEMA EIA Regulations of 2014.

14.4.5 Preliminary Vehicle Tracking Analysis and Road Widening/Lengthening Investigation

According to the NEMA EIA Regulations of 2014, the following relevant listed activities are noted:

Activity 56 of Listing Notice 1: The widening of a road by more than 6 metres, or the lengthening of a road by more than 1 kilometre -

- (i) where the existing reserve is wider than 13,5 meters; or
- (ii) where no reserve exists, where the existing road is wider than 8 metres.

For Activity 56 of Listing Notice 1, (i) *where the existing reserve is wider than 13,5 meters* is relevant.

Activity 18 (g) (ii) (ee) (ii) of Listing Notice 3: The widening of a road by more than four meters, or the lengthening of a road by more than one kilometre in the:

g. Northern Cape

ii. Outside urban areas:

(ee) Critical biodiversity areas as identified in systematic biodiversity plans adopted by the competent authority or in bioregional plans;

(ii) Areas within a watercourse or wetland; or within 100 metres from the edge of a watercourse or wetland.

Existing roads will be used as far as practically achievable. The proposed project study area can be accessed via various existing main roads and unnamed farm gravel roads. The potential access routes are discussed below, as per Section 14.4.2.3:

- Access Route Option 1:
 - Route A: Along TR38/01, DR3093, and DR3096;
 - Route B: Along TR38/01, DR3093 and DR3084;
- Access Route Option 2:
 - Route A: Along MR790, DR3093 and DR3084;
 - Route B: Along MR790 and DR3093;
 - Route C: Along MR790, DR3093 and DR3096;
- Access Route Option 3:
 - Route A: Along TR38/01, TR38/02, and DR3096;
 - Route B: Along TR38/01, TR38/02, DR3096 and DR3093; and
 - Route C: Along TR38/01, TR38/02, DR3096, DR3093 and DR3084.

The existing main roads, divisional roads and unnamed farm gravel roads may need to be upgraded for the proposed Kudu Solar cluster.

To accommodate the turning movements of abnormal vehicles, preliminary vehicle tracking was undertaken along the Access Route Options to determine areas where the existing road will need to be widened / lengthened. The following design vehicle was used (refer to Figure 14-14). The design vehicle will need to be confirmed during the geometric design process, however, the vehicle used is based on similar projects.

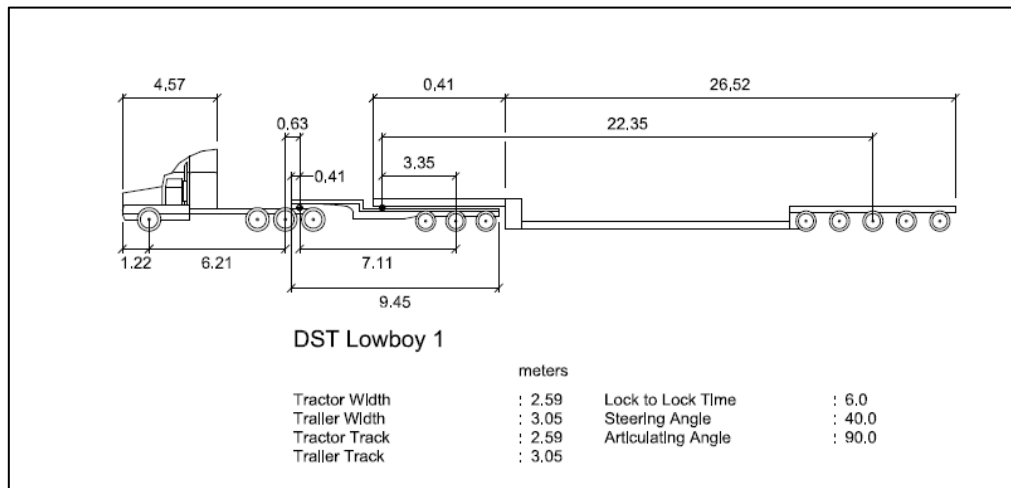

Figure 14-14: Abnormal Design Vehicle

Furthermore, based on similar studies, to accommodate the delivery of materials to site, the following intersection design at the main access point from the R48 is proposed as shown in Figure 14-15.

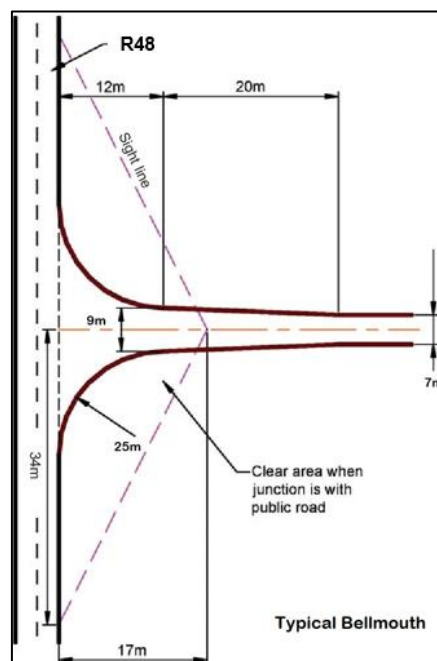

Figure 14-15: Intersection Design

The findings of the vehicle tracking based on the abnormal design vehicle for each access route option is discussed below.

14.4.5.1.1 Access Route Option 1

For this option, it is not anticipated that any widening of the intersection at TR38/01 and DR3093 will be required, however, the existing island will need to be removed (approximately 60 m²) to accommodate the turning movements as shown in Figure 14-16 and in accordance with Figure 14-15.

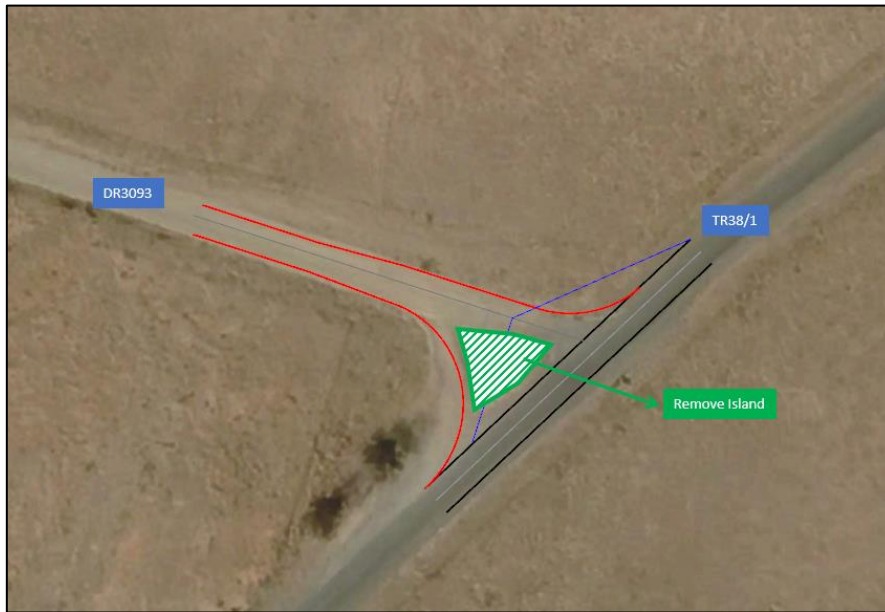

Figure 14-16: DR3093 and TR38/01 Intersection

No other widening or lengthening of roads will be required along this route.

14.4.5.1.2 Access Route Option 2

For this option, widening of the intersection at TR38/01 and MR790 will be required (approximately 95m²) to accommodate the turning movements as shown in Figure 14-17 and in accordance with Figure 14-15.



Figure 14-17: MR790 and TR38/01 Intersection

Furthermore, widening of the MR790/DR3093 intersection by approximately 60m² and widening of the DR3093/DR3084 intersection by 170m² will also be required as shown in Figure 14-18.



Figure 14-18: Access Route Option 2 Road Widening Requirements

No other widening or lengthening of roads will be required along this route.

14.4.5.1.3 Access Route Option 3

For this option, widening of the intersection at TR38/02 and DR3096 will be required (approximately 150m² in total) to accommodate the turning movements as shown in Figure 14-19 and in accordance with Figure 14-15.



Figure 14-19: Access Route Option 3 Road Widening Requirements

Furthermore, localised widening will be required along DR3096 at two locations (approximately 56m² heading north and 50m² heading west) and at the DR3093/DR3084 intersection (approximately 79m²) as shown in Figure 14-20.



Figure 14-20: Access Route Option 3 Road Widening Requirements

No other widening or lengthening of roads will be required along this route.

14.4.5.2 Conclusion Statement

Based on the wheel tracking analysis of the abnormal load vehicles that are discussed in Section 14.4.5, it can be concluded that no road will need to be lengthened by more than 1 kilometre for Access Route Option 1, Access Route Option 2 and Access Route Option 3. However, road widening exceeding 6m will be required for Access Route Option 2 only at the TR38/01 and MR790 intersection

(approximately 12m at the widest point) and at the DR3093 and DR3084 intersection (approximately 6.6m at the widest point). This is shown in Figure 14-21.



Figure 14-21: Road Widening Width at TR38/01 and MR790 and DR3093 and DR3084 intersections

Road widening exceeding 4m will be required for Access Route Option 3 at the TR38/02 and DR3096 intersection (approximately 4.4m at the widest point). This is shown in Figure 14-22.

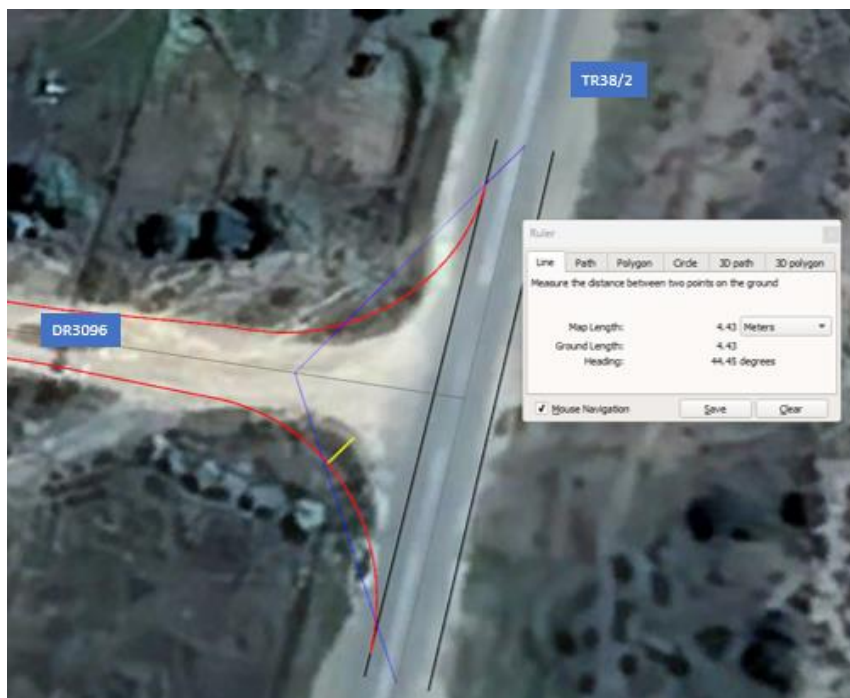

Figure 14-22: Road Widening Width at TR38/02 and DR3096 intersection

Road widening exceeding 4m and 6m will not be required for Access Route Option 1.

14.5 Existing Traffic Conditions

Temporary counting stations were commissioned by SANRAL in 2011 along the DR3093 and DR3084. The locations of the counting stations are indicated in Figure 14-23 below. The results of these counts indicated an Average Daily Traffic (ADT) of approximately 62 vehicles (two-way) along DR3093 and approximately 8 vehicles (two-way) along DR3084 per day. These numbers indicate that there are extremely low volumes of traffic along these roads in the vicinity of the study area. If an annual growth rate factor of 2% growth rate per annum is applied to these volumes, the ADT would increase to 79 vehicles (two-way) along DR3093 and 10 vehicles (two-way) along DR3084 per day, which is still extremely low traffic volumes. This growth rate relates to traffic growth experienced in low growth rate areas and is deemed appropriate for this area and could account for development that has taken place since 2011.

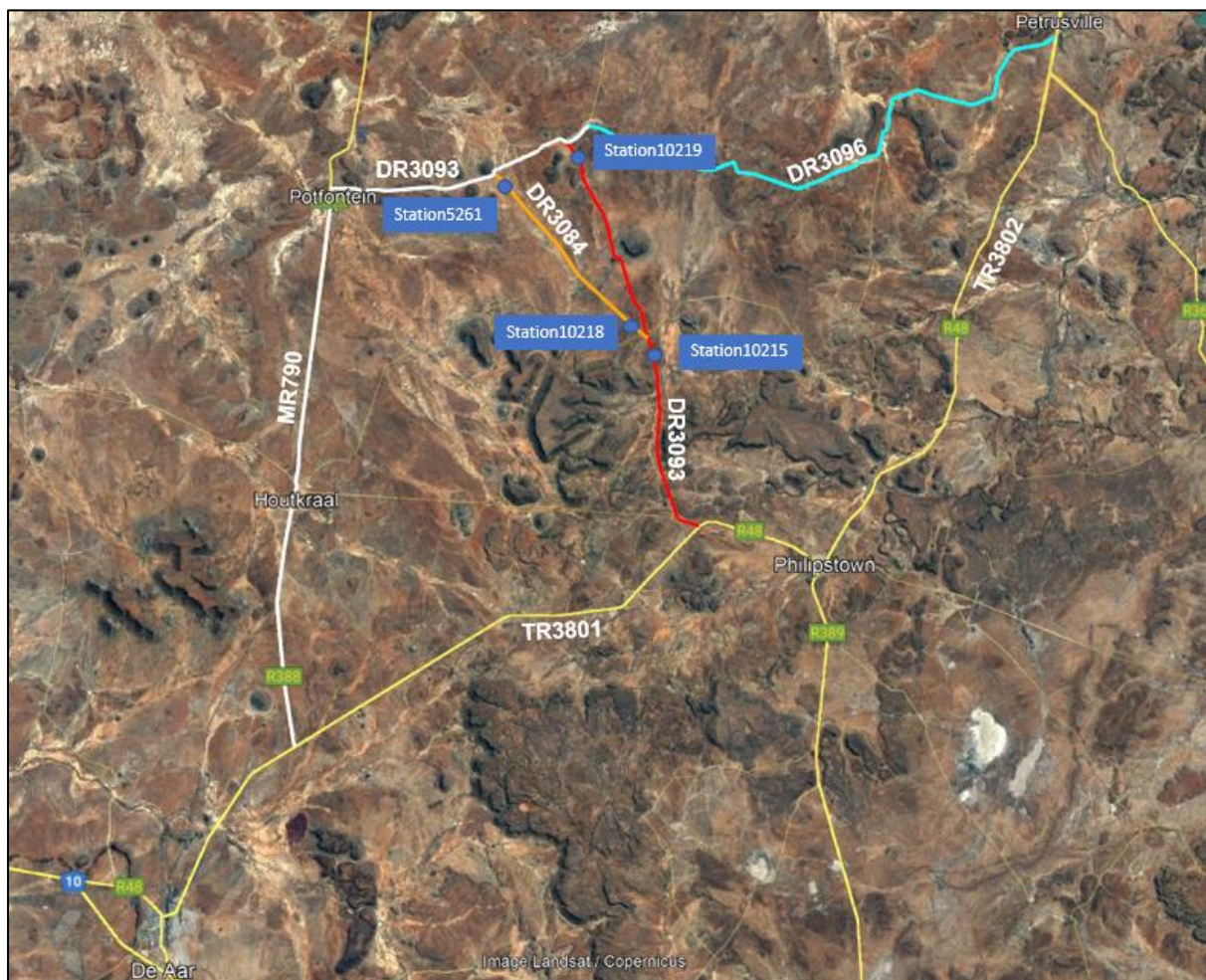

Figure 14-23: Location of Temporary Count Stations

SANRAL has two permanent counting stations, Station 13730 and Station 13731, in the vicinity of the site. Station 13730 is located along the R389 approximately 64 km northeast of De Aar and Station 13731 is located along the R48 approximately 102 km northeast of De Aar. The location of the counting stations is indicated in Figure 14-24 below.



Figure 14-24: Location of Permanent Count Stations

A summary of the ADT recorded at Station 13730 and Station 13731 is shown in Table 14-3 and Figure 14-25 below.

Table 14-3: Station 13730 and Station 13731 Count Data

Year	Average Traffic (ADT) (two-way)	
	Station 13730	Station 13731
2018	412	748
2019	454	648
2020	610	839
2021	626	866

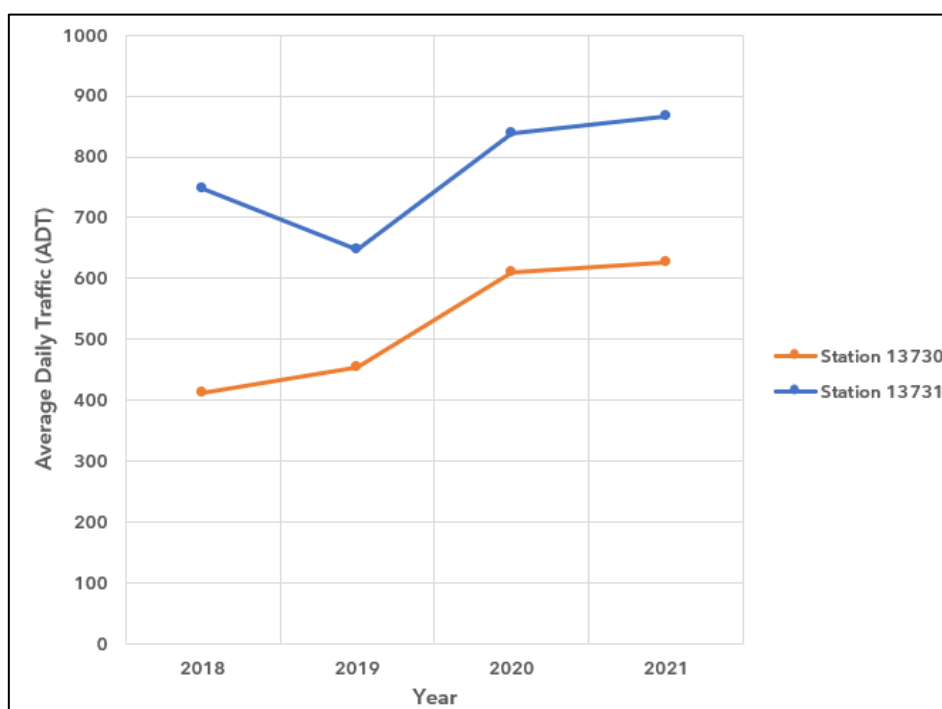

Figure 14-25: SANRAL Station 13730 and Station 13731 Historic Count Information

From the above information, it can be concluded that the growth rate from the recorded 2018 to 2021 ADT values is approximately 14% per annum along the R389 and approximately 5% per annum along the R48. Furthermore, the percentage of heavy vehicles recorded on the R389 was 78% during 2021 and 56% along the R48 during 2021. An increase in ADT is evident from 2020 onwards. This can possibly be attributed to increased mining activities and renewable energy projects. It should however be noted that the capacity of a Class 1 road with two lanes is in the order of 2000 vehicles per hour and therefore the traffic volumes recorded on this road is still significantly less than the capacity of the roads.

14.6 Trip Generation Rates

The trip generation rates discussed below are based on similar studies that have been undertaken for Solar Energy Facilities and associated electrical infrastructure (e.g. collector substation and transmission line). The trip generation rates discussed below relates to the anticipated trip generation rates associated with the 350MW Solar PV Facility.

14.6.1 Construction Phase

It is expected that the Construction Phase of the proposed Kudu Solar PV facility will be 12 to 18 months.

From experience with similar projects, it was assumed that for projects more than 150MW and up to 350MW, the following number of truck trips (one-way) are expected:

- Panels = 546 truck trips
- Mounting Structure = 600 truck trips
- Inverters = 26 truck trips
- Field Transformers = 24 truck trips
- Cable and Battery Operating System (BOS) = 240 truck trips

It is assumed that each project will be constructed over a 12 to 18 month period. Therefore, based on an 18-month construction period and a 6 day work week ($78 \times 6 = 468$ work days), this could result in approximately **3 daily truck trips (one-way)**.

It is also expected that approximately 6 single unit trucks carrying construction materials will visit the site on a daily basis, resulting in **6 daily single unit truck trips (one-way)**.

Furthermore, it is expected that approximately 300 workers will be transported to the site daily. It was assumed that 50% the workers will be transported to/from the site by 15-seater minibus taxis and 50% of the workers will be transported to/from the site by 80-seater buses from the surrounding areas resulting in approximately **10 daily staff minibus taxi trips (one-way)** and **2 daily bus trips (one-way)**. Experience has shown that during the construction period, approximately **4 daily private vehicle trips** are expected to come to/from the site from supervisors or senior personnel. Therefore, a total of **16 daily staff trips (one-way)** are expected.

Water will also be required during the construction phase for human consumption and construction activities, such as the installation of the solar panels, dust control along the gravel roads and potable water. As noted in Chapter 2 of this EIA Report, water may be sourced from the following sources, in order of priority: local municipality, third-party water supplier, existing boreholes or new drilled boreholes on site. For purposes of this TIA, the maximum development scenario in terms of water supply is used i.e. trucking in water from the local municipality. The water will be delivered to the site from a municipal water supply by 12 kilolitre water trucks on a daily basis. Based on similar projects, water demand will be in the order of approximately 18 000 m³ per year for the construction phase for construction purposes and potable water. This equates to 1 500 000 litres per month. This relates to an additional ~ **4 daily water truck trips (one-way)** to the site.

Based on the above, a total of **29 one-way trips per day**, i.e. **58 trips in total per day (two-way)** are expected during the 18 month period construction phase.

14.6.2 Operational Phase

It is expected that the Operational Phase will take place during the life span of the project (approximately 20 years). During this time, it is anticipated that 2 - 4 light load trucks will visit the site on a weekly basis. This will conservatively equate to **1 daily light load truck trip (one-way)**.

It is expected that a workforce of 16 members, made up of staff, supervisors or senior personnel will commute to the site by private vehicles daily. It is assumed that 3 workers will share a private vehicle, resulting in a total of **6 daily staff trips (one-way)**.

Water will be required for cleaning the solar panels, which must be done 4 times per year. It is also anticipated that the gravel district road be watered daily to suppress dust during operation depending

on traffic volumes. Based on similar projects, water demand will be in the order of approximately 2 000 m³ per year during the operational phase. This equates to 166 666 litres per month. The water will be delivered to the site from a municipal water supply by 12 kilolitre water trucks on a daily basis, resulting in **1 daily water truck trip (one-way)**.

Based on the above, a total of **8 one-way trips per day**, i.e. **16 trips in total per day (two-way)** are expected during the operational phase.

14.6.3 Decommissioning Phase

The Decommissioning Phase will generate similar trips as the Construction Phase over a similar time period of 18 months. This includes **3 daily truck trips (one-way)** trips for the transportation of the solar panels, **6 daily single unit truck trips (one-way)**, for the transportation of construction materials, **16 daily staff trips (one-way)** and **4 daily water truck trips (one-way)**.

Based on the above, a total of **29 one-way trips per day**, i.e. **58 trips in total per day (two-way)** are expected during the 18 month period decommissioning phase.

14.7 Trip Generation Summary

From the trip generation information gathered the following traffic impacts should be considered:

- Potential congestion and delays on the surrounding road network;
- Potential impact on traffic safety and increase in accidents with other vehicles or animals;
- Potential change in the quality of the surface condition of the roads; and
- Potential noise and dust pollution.

The number of additional daily trips per solar PV plant and associated electrical grid infrastructure are summarised below. These trips can be expected for the duration of the construction period and decommissioning phase (18 months) and for the operational phase of the project (20 years).

Construction Phase – 58 Daily Trips (two-way)

- 6 daily truck trips
- 12 daily light load trips
- 32 daily staff transport trips
- 8 daily water truck trips

Operational Phase – 16 Daily Trips (two-way)

- 2 daily light load truck trips
- 12 daily staff transport trips
- 2 daily water truck trips

Decommissioning Phase – 58 Daily Trips (two-way)

- 6 daily truck trips
- 12 daily light load trips
- 32 daily staff transport trips
- 8 daily water truck trips

It is anticipated that the PV facility will have an 18-month construction period. From historic traffic information in the vicinity of the site, traffic is evenly spread daily and the AM and PM peak hour trips each constitute approximately 7% of the daily traffic. This relates to approximately an additional 4 trips on the road network during the peak hours for the construction and decommissioning phase and approximately an additional 1 trip on the road network during the peak hours for the operational phase. **The additional peak hour trips during the construction, operational and decommissioning phases will have an insignificant traffic impact on the surrounding road network.**

However, possible mitigation measures to address the daily traffic impact are discussed in the following section.

14.8 Issues, Risks and Impacts

14.8.1 Identification of Potential Impacts/Risks

The potential transport and traffic related impacts identified are described below.

14.8.1.1 Construction Phase

The potential transport and traffic related impacts during the construction phase are listed below:

- Potential congestion and delays on the surrounding road network.
- Potential impact on traffic safety and increase in accidents with other vehicles or animals.
- Potential change in the quality of the surface condition of the roads.
- Potential noise and dust pollution.

14.8.1.2 Operational Phase

The traffic generated during the operational phase are mainly related to the staff that will be transported to and from the sites and are not anticipated to have a significant traffic impact on the surrounding road network.

14.8.1.3 Decommissioning Phase

The potential transport related impacts during the decommissioning phase are similar to the potential transport related impacts during the construction phase and are listed below:

- Potential congestion and delays on the surrounding road network.
- Potential impact on traffic safety and increase in accidents with other vehicles or animals.
- Potential change in the quality of the surface condition of the roads.
- Potential noise and dust pollution.

14.8.1.4 Cumulative Impacts

The cumulative transport impacts related to the proposed facility are listed below and apply to the construction and decommissioning phases:

- Congestion and delays on the surrounding road network.
- Impact on traffic safety and increase in accidents with other vehicles or animals.
- Change in the quality of the surface condition of the roads.
- Noise and dust pollution.

14.8.2 Summary of Issues identified during the Public Consultation Phase

During the 30-day review of the Draft Scoping Report, various comments were raised by stakeholders and Interested and Affected Parties (I&APs). The comments raised that relate to traffic related impacts are noted and summarised below, with responses provided by the specialist team:

NAME OF ORGANISATION/ I&AP	KEY ISSUE	RESPONSE
Adjacent Landowners	Queries on the maintenance of infrastructure (such as roads and water courses) and the management of dust pollution caused by the increased traffic.	Maintenance of existing infrastructure that is impacted by the proposed project during the construction and operational phase will be undertaken by the Project Developer. The requirements for maintenance are discussed in the Environmental Management Programme (EMPr). Similarly, mitigation measures to control and manage dust pollution that occurs as a result of the proposed project are included in the EMPr. The Applicant will place a significant emphasis on ensuring compliance with the management measures included. Dust pollution has been identified as a potential impact in this Traffic Impact Assessment, as well as the Visual Impact Assessment. Refer to Section 14.9 of this report for feedback on the potential dust pollution impact and mitigation measures, such as ensuring that speed control is implemented by means of a stop and go system and speed limit road signage within the construction site. Further management actions are also included in the EMPr.
Adjacent Landowner	A concern was raised regarding the dust pollution generated by the roads and the removal of vegetation.	The concerns regarding dust pollution are noted. Note that during the construction phase, vegetation is planned to be trimmed within the PV array area (and not removed completely). Therefore, even though it appears that a large area will be covered by the Solar PV array, not all the vegetation will be removed completely. This is also expected to reduce some of the dust generation. Nevertheless, dust management actions are included in the EMPr.

14.9 Impact Assessment

14.9.1 Potential Impacts during the Construction Phase

The impacts associated with the traffic generation of the proposed Kudu PV Facility 7 during the construction phase are summarised in Table 14-4 below, and discussed in detail below:

14.9.1.1 Impact 1: Potential congestion and delays on the surrounding road network.

Congestion and delays on the surrounding road network are identified as a potential impact as a result of increased traffic volumes relating to the trip generation of the construction activities during the peak hour periods. This impact is rated as neutral, with a local spatial extent and a medium-term duration. The impact is rated with a high reversibility (meaning that the potential impact is highly reversible at end of the project life); and is rated as replaceable (meaning the resources i.e. road network are replaceable). The potential impact is allocated a slight consequence and likely probability, which will render the impact significance as very low, without the implementation of mitigation measures. With the implementation of mitigation measures, the significance of the impact is also rated as very low. The recommended mitigation measures are detailed in Table 14-4 below.

14.9.1.2 Impact 2: Potential impact on traffic safety and increase in accidents with other vehicles or animals.

Traffic safety and an increase in accidents with other vehicles and animals is identified as a potential impact as a result of more vehicles travelling on the road to and from the construction site, increasing the likelihood of incidents. This impact is rated as negative, with a local spatial extent and a medium-term duration. The impact is rated with a low reversibility and high irreplaceability if the incident results in a fatality. The potential impact is allocated a substantial consequence and likely probability, which will render the impact significance as moderate, without the implementation of mitigation measures. With the implementation of mitigation measures, the significance of the impact is rated as low. The recommended mitigation measures are detailed in Table 14-4 below.

14.9.1.3 Impact 3: Potential change in the quality of the surface condition of the roads.

The potential change in the quality of the surface condition of the roads is identified as a potential impact as a result of the increase in especially heavy vehicle traffic on the roads. This impact is rated as neutral, with a local spatial extent and a medium-term duration. The impact is rated with a high reversibility (meaning that the potential impact is highly reversible at end of the project life); and is rated as replaceable (meaning the resources i.e. road network are replaceable). The potential impact is allocated a slight consequence and likely probability, which will render the impact significance as very low, without the implementation of mitigation measures. With the implementation of mitigation measures, the significance of the impact is also rated as very low. The recommended mitigation measures are detailed in Table 14-4 below.

14.9.1.4 Impact 4: Potential noise pollution.

The potential of noise pollution is identified as a potential impact as a result of increased traffic volumes during the construction phase of the project. This impact is rated as neutral, with a local spatial extent and a medium-term duration. The impact is rated with a high reversibility (meaning that the potential impact is highly reversible at end of the project life); and is rated as replaceable (meaning the resources i.e. road network are replaceable). The potential impact is allocated a moderate consequence and likely probability, which will render the impact significance as low, without the implementation of mitigation measures. With the implementation of mitigation measures, the significance of the impact is also rated as low. The recommended mitigation measures are detailed in Table 14-4 below.

14.9.1.5 Impact 5: Potential dust pollution.

The potential of dust pollution is identified as a potential impact as a result of the increased number of vehicles using the gravel roads to access the proposed construction site. This impact is rated as neutral, with a local spatial extent and a medium-term duration. The impact is rated with a high reversibility (meaning that the potential impact is highly reversible at end of the project life); and is rated as replaceable (meaning the resources i.e. road network are replaceable). The potential impact is allocated a moderate consequence and likely probability, which will render the impact significance as low, without the implementation of mitigation measures. With the implementation of mitigation measures, the significance of the impact is also rated as low. The recommended mitigation measures are detailed in Table 14-4 below.

14.9.1.6 Impact Summary Tables: Construction Phase

Table 14-4: Rating of Traffic Related Impacts During the Construction Phase

Impact	Impact Criteria		Significance and Ranking (Pre-Mitigation)	Potential mitigation measures	Significance and Ranking (Post-Mitigation)	Confidence Level
CONSTRUCTION PHASE						
Congestion and delays on road network	Status	Neutral	Very Low (5)	Stagger delivery trips and schedule trips, including staff trips outside of peak hours where possible.	Very Low (5)	High
	Spatial Extent	Local				
	Duration	Medium Term				
	Consequence	Slight				
	Probability	Likely				
	Reversibility	High				
Potential impact on traffic safety and increase in accidents with other vehicles and animals	Status	Negative	Moderate (3)	Implement speed control by means of a stop and go system and speed limit road signage within the construction site. Ensure all vehicles are roadworthy, visible, adequately marked, and operated by an appropriately licenced operator.	Low (4)	High
	Spatial Extent	Local				
	Duration	Medium Term				
	Consequence	Substantial				
	Probability	Likely				
	Reversibility	Low				
Condition of road surface	Status	Neutral	Very Low (5)	Regular maintenance of internal farm access roads by the contractor. Ensure private access roads that are impacted on by the proposed development are restored to original pre-construction road condition.	Very Low (5)	High
	Spatial Extent	Local				
	Duration	Medium Term				
	Consequence	Slight				
	Probability	Likely				
	Reversibility	High				
Dust Pollution	Status	Neutral	Low (4)	Implement dust control on gravel roads within the construction site. Implement speed control by means of a stop and go system and speed limit road signage within the construction site.	Low (4)	High
	Spatial Extent	Local				
	Duration	Medium Term				
	Consequence	Moderate				
	Probability	Likely				
	Reversibility	High				
Noise Pollution	Status	Neutral	Low (4)	Stagger delivery trips.	Low (4)	High
	Spatial Extent	Local				
	Duration	Medium Term				
	Consequence	Moderate				

Impact	Impact Criteria		Significance and Ranking (Pre-Mitigation)	Potential mitigation measures	Significance and Ranking (Post-Mitigation)	Confidence Level
	Probability	Likely				
	Reversibility	High				
	Irreplaceability	Replaceable				

14.9.2 Potential Impacts during the Operational Phase

The traffic generated during the operational phase will not have a significant impact on the surrounding road network.

14.9.3 Potential Impacts during the Decommissioning Phase

The impacts associated with the traffic generation of the proposed Kudu PV Facility during the decommissioning phase are summarised in Table 14-5 below:

14.9.3.1 Impact 1: Potential congestion and delays on the surrounding road network.

Congestion and delays on the surrounding road network are identified as a potential impact as a result of increased traffic volumes relating to the trip generation of the facility for decommissioning activities during the peak hour periods. This impact is rated as neutral, with a local spatial extent and a medium-term duration. The impact is rated with a high reversibility (meaning that the potential impact is highly reversible at end of the project life); and is rated as replaceable (meaning the resources i.e. road network are replaceable). The potential impact is allocated a slight consequence and likely probability, which will render the impact significance as very low, without the implementation of mitigation measures. With the implementation of mitigation measures, the significance of the impact is also rated as very low. The recommended mitigation measures are detailed in Table 14-5 below.

14.9.3.2 Impact 2: Potential impact on traffic safety and increase in accidents with other vehicles or animals.

Traffic safety and increase in accidents with other vehicles and animals is identified as a potential impact as a result of more vehicles travelling on the road to and from the facility for decommissioning activities, increasing the likelihood of incidents. This impact is rated as negative, with a local spatial extent and a medium-term duration. The impact is rated with a low reversibility and high irreplaceability if the incident results in a fatality. The potential impact is allocated a substantial consequence and likely probability, which will render the impact significance as moderate, without the implementation of mitigation measures. With the implementation of mitigation measures, the significance of the impact is rated as low. The recommended mitigation measures are detailed in Table 14-5 below.

14.9.3.3 Impact 3: Potential change in the quality of the surface condition of the roads.

The potential change in the quality of the surface condition of the roads is identified as a potential impact as a result of the increase in especially heavy vehicle traffic on the roads due to decommissioning activities. This impact is rated as neutral, with a local spatial extent and a medium-term duration. The impact is rated with a high reversibility (meaning that the potential impact is highly reversible at end of the project life); and is rated as replaceable (meaning the resources i.e. road network are replaceable). The potential impact is allocated a slight consequence and likely probability, which will render the impact significance as very low, without the implementation of mitigation measures. With the implementation of mitigation measures, the significance of the impact is also rated as very low. The recommended mitigation measures are detailed in Table 14-5 below.

14.9.3.4 Impact 4: Potential noise pollution.

The potential of noise pollution is identified as a potential impact as a result of increased traffic volumes during the decommissioning phase of the project. This impact is rated as neutral, with a local spatial extent and a medium-term duration. The impact is rated with a high reversibility (meaning that the potential impact is highly reversible at end of the project life); and is rated as replaceable (meaning the resources i.e. road network are replaceable). The potential impact is allocated a moderate consequence and likely probability, which will render the impact significance as low, without the implementation of mitigation measures. With the implementation of mitigation measures, the significance of the impact is also rated as low. The recommended mitigation measures are detailed in Table 14-5 below.

14.9.3.5 Impact 5: Potential dust pollution.

The potential of dust pollution is identified as a potential impact as a result of increased number of vehicles using the gravel roads to access the proposed facility for decommissioning activities. This impact is rated as neutral, with a local spatial extent and a medium-term duration. The impact is rated with a high reversibility (meaning that the potential impact is highly reversible at end of the project life); and is rated as replaceable (meaning the resources i.e. road network are replaceable). The potential impact is allocated a moderate consequence and likely probability, which will render the impact significance as low, without the implementation of mitigation measures. With the implementation of mitigation measures, the significance of the impact is also rated as low. The recommended mitigation measures are detailed in Table 14-5 below.

14.9.3.6 Impact Summary Tables: Decommissioning Phase

Table 14-5: Rating of Traffic Related Impacts During the Decommissioning Phase

Impact	Impact Criteria		Significance and Ranking (Pre-Mitigation)	Potential mitigation measures	Significance and Ranking (Post-Mitigation)	Confidence Level
DECOMMISSIONING PHASE						
Congestion and delays on road network	Status	Neutral	Very Low (5)	<ul style="list-style-type: none"> Stagger delivery trips and schedule trips, including staff trips outside of peak hours where possible. 	Very Low (5)	High
	Spatial Extent	Local				
	Duration	Medium Term				
	Consequence	Slight				
	Probability	Likely				
	Irreplaceability	Replaceable				
Potential impact on traffic safety and increase in accidents with other vehicles and animals	Status	Negative	Moderate (3)	<ul style="list-style-type: none"> Implement speed control by means of a stop and go system and speed limit road signage within the decommissioning site. Ensure all vehicles are roadworthy, visible, adequately marked, and operated by an appropriately licenced operator. 	Low (4)	High
	Spatial Extent	Local				
	Duration	Medium Term				
	Consequence	Substantial				
	Probability	Likely				
	Irreplaceability	High				
Condition of road surface	Status	Neutral	Very Low (5)	<ul style="list-style-type: none"> Regular maintenance of internal farm access roads by the contractor. Ensure private access roads that are impacted on by the proposed development are restored to original pre-construction road condition. 	Very Low (5)	High
	Spatial Extent	Local				
	Duration	Medium Term				
	Consequence	Slight				
	Probability	Likely				
	Irreplaceability	Replaceable				
Dust Pollution	Status	Neutral	Low (4)	<ul style="list-style-type: none"> Implement dust control on gravel roads within the decommissioning site. Implement speed control by means of a stop and go system and speed limit road signage within the decommissioning site. 	Low (4)	High
	Spatial Extent	Local				
	Duration	Medium Term				
	Consequence	Moderate				
	Probability	Likely				
	Irreplaceability	Replaceable				
Noise Pollution	Status	Neutral	Low (4)	<ul style="list-style-type: none"> Stagger delivery trips. 	Low (4)	High
	Spatial Extent	Local				
	Duration	Medium Term				
	Consequence	Moderate				

Impact	Impact Criteria		Significance and Ranking (Pre-Mitigation)	Potential mitigation measures	Significance and Ranking (Post-Mitigation)	Confidence Level
	Probability	Likely				
	Reversibility	High				
	Irreplaceability	Replaceable				

14.9.4 Cumulative Impacts

It is very unlikely that all 12 Kudu PV projects will occur at the same time and construction will most likely be staggered based on project and site-specific aspects. However, the potential cumulative traffic impact related to the construction and decommissioning phases are shown in the table below based on the assumption of all 12 PV projects being constructed at the same time. The cumulative traffic impact related to the operational phase can still be regarded as insignificant.

The biggest traffic impact associated with renewable energy facilities is during the construction phase (and similarly during the decommissioning phase). During the operational phase, the trips added to the road network is expected to be insignificant. It should be noted that all the applications for abnormal load transport are considered by the applicable authorities, and they will ensure that the trips are staggered on the road network to limit possible delays.

Other renewable energy and EGI developments within a 30 km radius are also considered in this cumulative impact assessment as part of the EIA Phase. Refer to Figure 14-26 below for a map of the other renewable energy developments and EGI considered, as well as a corresponding list of projects in Table 14-6. Some of these projects are already constructed and operational (selected preferred bidders or existing power lines), currently in the Environmental Assessment phase, or have received Environmental Authorisation, or are planned. In reality it is however very unlikely that all the proposed projects will occur at the same time, as all these projects will be subject to a highly competitive bidding process and only a few projects would be allowed to enter into a power purchase agreement at a time. Construction will most likely be staggered based on project and site-specific issues. In addition, as noted above, the applicable authorities will consider abnormal load applications and work with the applicants to ensure that staggering and phasing of loads on public roads is achieved to minimise impacts.

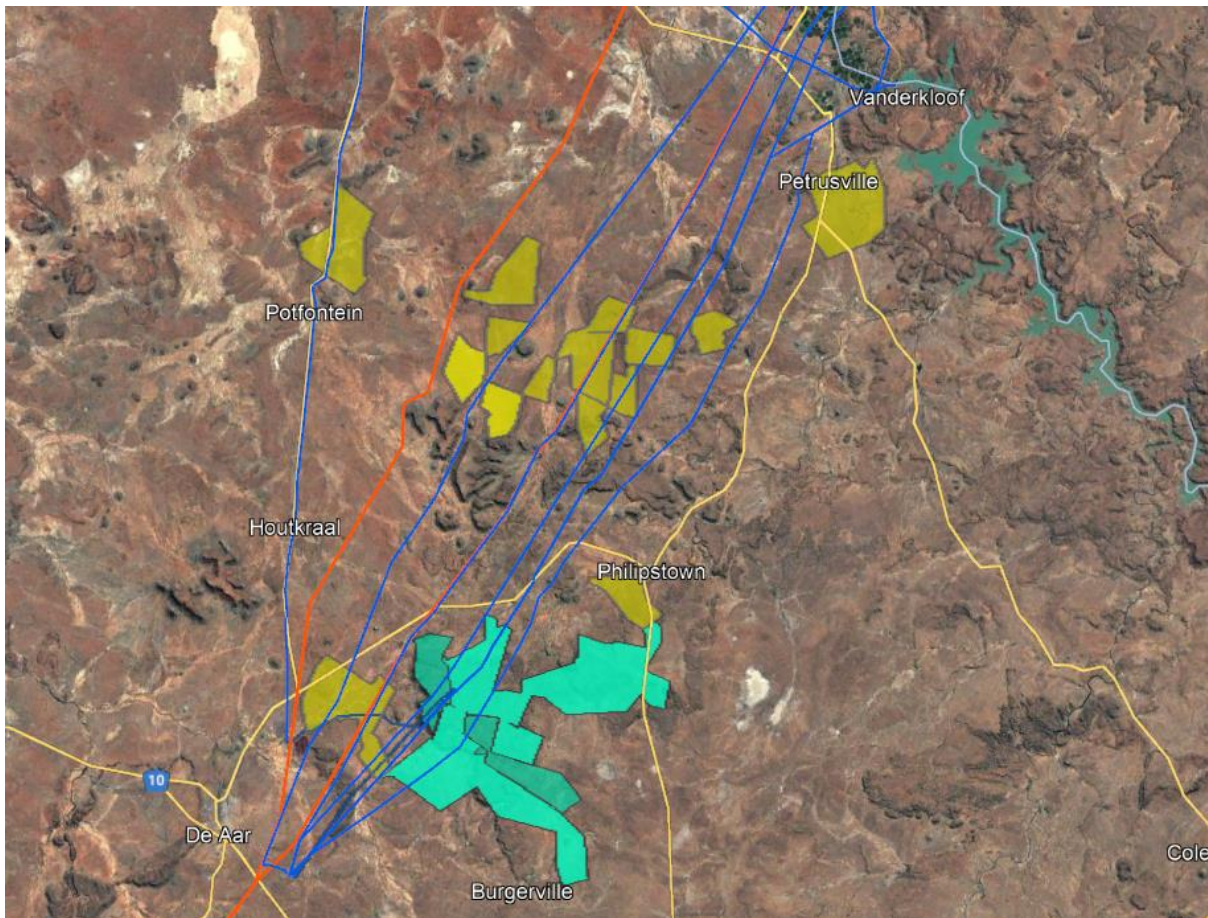

Figure 14-26: Renewable Energy Developments and EGI within 30km Radius

Table 14-6: Proposed renewable energy and EGI projects, located within 30 km of the proposed Kudu Solar Facilities, that are considered in the Cumulative Impact Assessment (Source: DFFE REEA, Quarter 4, 2022; and SAHRIS)

CSIR NUMBER	DFFE REFERENCE	TECHNOLOGY	MW/KV	STATUS	PROJECT TITLE	EIA REGULATIONS	ASSESSMENT PROCESS	APPLICANT	EAP
1	<ul style="list-style-type: none"> 12/12/20/2258 12/12/20/2258/1 	Solar PV	75	Approved and Preferred Bidder (Operational)	<ul style="list-style-type: none"> The Proposed Establishment of Photovoltaic (Solar Power) Farms in the Northern Cape Province - Kalkbult 	2010	Scoping and EIA	Scatec Solar SA Pty Ltd	Sustainable Development Projects cc
2	<ul style="list-style-type: none"> 12/12/20/2463/1 12/12/20/2463/1/2 12/12/20/2463/1/A2 12/12/20/2463/1/AM3 12/12/20/2463/1/AM4 12/12/20/2463/1/AM5 	Onshore Wind	140	Approved and Preferred Bidder (Operational)	<ul style="list-style-type: none"> Longyuan Mulilo De Aar 2 North Wind Energy Facility Longyuan Mulilo De Aar Maanhaarberg Wind Energy Facility The Wind Energy Facility (North and South) situated on the Plateau Near De Aar, Northern Cape Province 	2010 and 2014	Scoping and EIA and Amendment	Longyuan Mulilo De Aar 2 South (Pty)	Aurecon South Africa (Pty) Ltd and Holland and Associates Environmental Consultants
3	<ul style="list-style-type: none"> 12/12/20/2463/2 12/12/20/2463/2/AM2 	Onshore Wind	100	Approved and Preferred Bidder (Operational)	<ul style="list-style-type: none"> Longyuan Mulilo De Aar Maanhaarberg Wind Energy Facility The Wind Energy Facility (North and South) Situated on The Plateau Near De Aar, Northern Cape Province 	2010 and 2014	Scoping and EIA and Amendment	Mulilo Renewable Energy (Pty) Ltd	Aurecon South Africa (Pty) Ltd
4	<ul style="list-style-type: none"> 14/12/16/3/3/1/1166 14/12/16/3/3/1/1166/AM3 14/12/16/3/3/1/1166/AM4 	Transmission line	132	Approved	<ul style="list-style-type: none"> Basic Assessment for the proposed construction of a 132 kV transmission line corridor adjacent to the existing Eskom transmission line from Longyuan Mulilo De Aar 2 North Wind Energy Facility (WEF) to the Hydra Substation in De Aar, Northern Cape 	2010 and 2014	Basic Assessment	Longyuan Mulilo De Aar 2 North (Pty) Ltd	Aurecon South Africa (Pty) Ltd
5	<ul style="list-style-type: none"> 14/12/16/3/3/1/785 	Transmission line	132	Approved	<ul style="list-style-type: none"> Proposed construction of two 132kV transmission lines from the South & North Wind Energy Facilities on the Eastern Plateau (De Aar 2) near De Aar, Northern Cape. 	2010	Basic Assessment	Mulilo Renewable Energy (Pty) Ltd	Aurecon South Africa (Pty) Ltd
6	<ul style="list-style-type: none"> 14/12/16/3/3/2/278 14/12/16/3/3/2/278/1 14/12/16/3/3/2/278/2 	Onshore Wind	118	Approved	<ul style="list-style-type: none"> Proposed Castle Wind Energy Facility Project, located near De Aar, Northern Cape 	2010 and 2014	Scoping and EIA	Castle Wind Farm (Pty) Ltd	Aurecon South Africa (Pty) Ltd; and Savannah Environmental Consultants (Pty) Ltd
7	<ul style="list-style-type: none"> 14/12/16/3/3/2/564 14/12/16/3/3/2/564/AM1 14/12/16/3/3/2/564/AM2 	Solar PV	75	To be confirmed	<ul style="list-style-type: none"> Proposed Swartwater 75MW solar PV power facility in Petrusville within Renosterburg Local Municipality, Northern Cape 	2010 and 2014	Scoping and EIA and Amendment	AE-AMD Renewable Energy (Pty) Ltd	USK Environmental and Waste Engineering (Pty) Ltd
8	<ul style="list-style-type: none"> 14/12/16/3/3/2/740 	Solar PV	300	Approved	<ul style="list-style-type: none"> Proposed 300MW Solar Power Plant in Phillipstown area in Renosterberg Local Municipality 	2010	Scoping and EIA	To be confirmed	Tshikovha Environmental and Communication Consultants
9	<ul style="list-style-type: none"> 14/12/16/3/3/2/744 	Solar PV	Unknown	Approved	<ul style="list-style-type: none"> Proposed PV facility on farm Jakhalsfontein near De Aar 	2010	Scoping and EIA	Solar Capital (Pty) Ltd	Eco Compliance (Pty) Ltd
10	<ul style="list-style-type: none"> 14/12/16/3/3/2/739 	Solar PV	70 - 100	To be confirmed	<ul style="list-style-type: none"> Proposed 70 - 100 MW Solar Power Plant in Petrusville 	2010	Scoping and EIA	To be confirmed	Tshikovha Environmental and Communication Consultants
11	<ul style="list-style-type: none"> Not issued yet (it is understood that the project is still within the pre-application stage) 	Solar PV	800 (Maximum)	Pre-Application	<ul style="list-style-type: none"> The Proposed Keren Energy Odyssey Solar PV Facilities (Odyssey Solar 1, Odyssey Solar 2, Odyssey Solar 3, Odyssey Solar 4, Odyssey Solar 5, Odyssey Solar 6, Odyssey Solar 7 And Odyssey Solar 8) 	2014	Scoping and EIA	Keren Energy Group Holdings	EnviroAfrica cc
12	<ul style="list-style-type: none"> To be confirmed 	Solar PV	3050	Scoping	<ul style="list-style-type: none"> The Proposed Development of the Crossroads (formally referred to as the Hydra B) Green Energy Cluster of Renewable Energy Facilities and Grid Connection Infrastructure, Pixley Ka Seme District Municipality, Northern Cape Province. The Cluster entails the development of up to 21 solar energy facilities, with the Scoping and EIA Processes consisting of three phases. Phases 1, 2 and 3 consist of 9, 6 and 6 solar facilities, respectively. The Phase 1 Scoping and EIA Processes were launched in January 2023. 	2014	Scoping and EIA	Akuo Energy Afrique	Savannah Environmental Consultants (Pty) Ltd
Study area shown on map	<ul style="list-style-type: none"> 14/12/16/3/3/2/2244 14/12/16/3/3/2/2245 14/12/16/3/3/2/2246 14/12/16/3/3/2/2247 14/12/16/3/3/2/2248 14/12/16/3/3/2/2249 14/12/16/3/3/2/2250 14/12/16/3/3/2/2251 14/12/16/3/3/2/2252 14/12/16/3/3/2/2253 	Solar PV	2180	Scoping and EIA Process underway	<ul style="list-style-type: none"> Proposed Development of 12 Solar Photovoltaic (PV) Facilities (Kudu Solar Facility 1 to 12) and associated infrastructure, near De Aar, Northern Cape Province 	2014	Scoping and EIA	Kudu Solar Facility 1 (Pty) Ltd to Kudu Solar Facility 12 (Pty) Ltd	CSIR

CSIR NUMBER	DFFE REFERENCE	TECHNOLOGY	MW/KV	STATUS	PROJECT TITLE	EIA REGULATIONS	ASSESSMENT PROCESS	APPLICANT	EAP
	<ul style="list-style-type: none"> 14/12/16/3/3/2/2254 14/12/16/3/3/2/2255 								
Shown on map as Existing HV Lines	<ul style="list-style-type: none"> N/A 	Transmission Line	220	Existing Power Line	<ul style="list-style-type: none"> HYDRA ROODEKUIL 2 	-	-	-	-
Shown on map as Existing HV Lines	<ul style="list-style-type: none"> N/A 	Transmission Line	132	Existing Power Line	<ul style="list-style-type: none"> HYDRA ROODEKUIL 1 	-	-	-	-
Shown on map as Existing HV Lines	<ul style="list-style-type: none"> N/A 	Transmission Line	765	Existing Power Line	<ul style="list-style-type: none"> BETA HYDRA 2 	-	-	-	-
Shown on map as Existing HV Lines	<ul style="list-style-type: none"> N/A 	Transmission Line	400	Existing Power Line	<ul style="list-style-type: none"> HYDRA PERSEUS 3 	-	-	-	-
Shown on map as Existing HV Lines	<ul style="list-style-type: none"> N/A 	Transmission Line	220	Existing Power Line	<ul style="list-style-type: none"> VAN DER KLOOF ROODEKUIL 2 	-	-	-	-
Shown on map as Existing HV Lines	<ul style="list-style-type: none"> N/A 	Transmission Line	220	Existing Power Line	<ul style="list-style-type: none"> VAN DER KLOOF ROODEKUIL 1 	-	-	-	-
Shown on map as Existing HV Lines	<ul style="list-style-type: none"> N/A 	Transmission Line	400	Existing Power Line	<ul style="list-style-type: none"> BETA HYDRA 1 	-	-	-	-
Shown on map as Existing HV Lines	<ul style="list-style-type: none"> N/A 	Transmission Line	400	Existing Power Line	<ul style="list-style-type: none"> HYDRA PERSEUS 2 	-	-	-	-
Shown on map as Existing HV Lines	<ul style="list-style-type: none"> N/A 	Transmission Line	132	Existing Power Line	<ul style="list-style-type: none"> KALKBULT/KAREEBOSCHPAN 1 	-	-	-	-
Shown on map as Existing HV Lines	<ul style="list-style-type: none"> N/A 	Transmission Line	132	Existing Power Line	<ul style="list-style-type: none"> ROODEKUIL/ORANIA 1 	-	-	-	-
Shown on map as Planned HV Lines	<ul style="list-style-type: none"> N/A 	Transmission Line	765	Planned Power Line	<ul style="list-style-type: none"> Perseus to Gamma 2nd 765 kV line Cape Corridor Phase 4: 2nd Zeus-Per-Gam-Ome 765kV Line 	-	-	-	-
Shown on map as Planned HV Lines	<ul style="list-style-type: none"> N/A 	Transmission Line	765	Planned Power Line	<ul style="list-style-type: none"> Relocate Beta-Hydra 765kV line to form Perseus-Hydra 1st 765kV line Cape Corridor Phase 2: Zeus - Hydra 765kV Integration 	-	-	-	-
Shown on map as Planned HV Lines	<ul style="list-style-type: none"> N/A 	Transmission Line	765	Planned Power Line	<ul style="list-style-type: none"> Perseus to Gamma 2nd 765 kV line Cape Corridor Phase 4: 2nd Zeus-Per-Gam-Ome 765kV Line 	-	-	-	-

Refer to Table 14-7 below for a rating of the potential cumulative impacts.

Table 14-7: Rating of Cumulative Traffic Related Impacts during the Construction and Decommissioning Phase

Impact	Impact Criteria		Significance and Ranking (Pre-Mitigation)	Potential mitigation measures	Significance and Ranking (Post-Mitigation)	Confidence Level
CONSTRUCTION AND DECOMMISSIONING PHASE						
Congestion and delays on road network	Status	Neutral	Moderate (3)	<ul style="list-style-type: none"> Stagger delivery trips and schedule trips, including staff trips outside of peak hours where possible. 	Low (4)	High
	Spatial Extent	Local				
	Duration	Medium Term				
	Consequence	Substantial				
	Probability	Unlikely				
	Reversibility	High				
Potential impact on traffic safety and increase in accidents with other vehicles and animals	Status	Negative	Moderate (3)	<ul style="list-style-type: none"> Implement speed control by means of a stop and go system and speed limit road signage within the construction and decommissioning site. Ensure all vehicles are roadworthy, visible, adequately marked, and operated by an appropriately licenced operator. 	Low (4)	High
	Spatial Extent	Local				
	Duration	Medium Term				
	Consequence	Substantial				
	Probability	Unlikely				
	Reversibility	Low				
Condition of road surface	Status	Neutral	Moderate (3)	<ul style="list-style-type: none"> Regular maintenance of internal farm access roads by the contractor. Ensure private access roads that are impacted on by the proposed development are restored to original pre-construction road condition. 	Very Low (5)	High
	Spatial Extent	Local				
	Duration	Medium Term				
	Consequence	Substantial				
	Probability	Unlikely				
	Reversibility	High				
Dust Pollution	Status	Neutral	Low (4)	<ul style="list-style-type: none"> Implement dust control on gravel roads within the decommissioning site. Implement speed control by means of a stop and go system and speed limit road signage within the construction and decommissioning site. 	Low (4)	High
	Spatial Extent	Local				
	Duration	Medium Term				
	Consequence	Moderate				
	Probability	Unlikely				
	Reversibility	High				
Noise Pollution	Status	Neutral	Low (4)	<ul style="list-style-type: none"> Stagger delivery trips. 	Low (4)	High
	Spatial Extent	Local				
	Duration	Medium Term				
	Consequence	Moderate				

Impact	Impact Criteria		Significance and Ranking (Pre-Mitigation)	Potential mitigation measures	Significance and Ranking (Post-Mitigation)	Confidence Level
	Probability	Unlikely				
	Reversibility	High				
	Irreplaceability	Replaceable				

14.9.5 Battery Energy Storage System

A Lithium-Ion Battery Energy Storage System (BESS) and Redox Flow BESS were both considered for the proposed project. For Redox Flow BESS, various chemical compositions are likely, such as Vanadium. Refer to Chapter 15 of this EIA Report for a High-Level Safety, Health and Environment Risk Assessment, which provides high level information on the safety, health and environmental risks of the BESS technologies.

Both BESS technologies have been considered in this assessment. This type of technology will have no significant influence on traffic; therefore, both are considered viable from a traffic perspective. The traffic impacts discussed in Section 14.9 are also associated with the BESS.

14.9.6 No-Go Option

The no-go option will result in no additional impacts on traffic and will result in the road and traffic status quo being maintained. However, with that being said, no fatal flaws were discovered in the course of the investigations for the proposed Kudu Solar Facilities, and with mitigation the potential impact significance is rated as mainly low to very low.

14.10 Impact Assessment Summary

The overall impact significance findings, following the implementation of the proposed mitigation measures are shown in the Table 14-8 below:

Table 14-8: Overall Impact Significance (Post Mitigation)

Phase	Overall Impact Significance
Construction	Low to Very Low Risk / Impact (4-5)
Operational	Insignificant
Decommissioning	Low to Very Low Risk / Impact (4-5)
Nature of Impact	Overall Impact Significance
Cumulative - Construction	Low Risk / Impact (4)
Cumulative - Operational	Insignificant
Cumulative - Decommissioning	Low to Very Low Risk / Impact (4-5)

14.11 Legislative and Permit Requirements

The Legislative and Permit requirements pertaining to the transport requirements for the proposed project is listed below:

- Abnormal load permits, (Section 81 of the National Road Traffic Act)
- Port permit (Guidelines for Agreements, Licenses and Permits in terms of the National Ports Act No. 12 of 2005), and
- Authorisation from Road Authorities to modify the road reserve to accommodate turning movements of abnormal loads at intersections.

14.12 Environmental Management Programme Inputs

The EMPr inputs for traffic related impacts is shown in Table 14-9 below.

Table 14-9: Environmental Management Programme for Traffic Impacts

Impact	Mitigation/Management Objectives	Mitigation/Management Actions	Monitoring		
			Methodology	Frequency	Responsibility
A. PLANNING AND DESIGN PHASE					
<ul style="list-style-type: none"> Increased traffic generation 	Manage impact that additional traffic generation will have on road network	<ul style="list-style-type: none"> If abnormal loads need to be transported by road to the site, a permit will need to be applied for in terms of Section 81 of the National Road Traffic Act and authorisation needs to be obtained from the relevant road authorities to modify the road reserve to accommodate turning movements at intersections (if necessary). It is not anticipated that any widening of the intersection at TR38/01 and DR3093 will be required, however, the existing island will need to be removed (approximately 60 m²) to accommodate the turning movements of the abnormal load vehicles. 	<ul style="list-style-type: none"> Ensure that the permits and authorisations are applied for and obtained prior to commencement. Verify that this has been undertaken by reviewing approved permits. 	<ul style="list-style-type: none"> Once-off during the planning and design phase Once-off during the planning and design phase. 	<ul style="list-style-type: none"> Contractor ECO
		<ul style="list-style-type: none"> The route to the sites should be further investigated to ensure that abnormal loads are not obstructed at any point by geometric, height and width limitations along the route. 	<ul style="list-style-type: none"> Ensure that this is taken into consideration during the planning and design phase by reviewing signed minutes of meetings or signed reports. 	<ul style="list-style-type: none"> Once-off during the planning and design phase. 	<ul style="list-style-type: none"> Project Developer and Traffic Specialist
		<ul style="list-style-type: none"> Discussions must be held with the relevant landowners on which the internal farm access roads leading to the site is located, prior to commencement to confirm requirements. 	<ul style="list-style-type: none"> Ensure that this is taken into consideration during the planning and design phase by reviewing signed minutes of meetings or signed reports. 	<ul style="list-style-type: none"> Once-off during the planning and design phase. 	<ul style="list-style-type: none"> Project Developer and ECO
		<ul style="list-style-type: none"> Ensure that the requirements for use of the internal farm access roads leading to the sites are addressed and considered in the design, as and where applicable. 	<ul style="list-style-type: none"> Ensure that this is taken into consideration during the planning and design phase by reviewing signed minutes of meetings or signed reports. 	<ul style="list-style-type: none"> Once-off during the planning and design phase. 	<ul style="list-style-type: none"> Project Developer and ECO

Impact	Mitigation/Management Objectives	Mitigation/Management Actions	Monitoring		
			Methodology	Frequency	Responsibility
		<ul style="list-style-type: none"> Provide a Transport Traffic Plan to the Provincial and Municipal Road Department (if required). 	<ul style="list-style-type: none"> Ensure that the plan is compiled and submitted prior to commencement. Verify that this has been undertaken by reviewing approved plans. 	<ul style="list-style-type: none"> Once-off during the planning and design phase Once-off during the planning and design phase. 	<ul style="list-style-type: none"> Contractor ECO
<ul style="list-style-type: none"> Accelerated degradation of road structure due to construction, operational and decommissioning phase traffic. 	Limit the deterioration of the road condition due to construction, operational and decommissioning phase traffic.	<ul style="list-style-type: none"> A Road Maintenance Plan should be developed for the internal farm access roads (i.e. internal private roads leading off the DR3093) that will be used. The plan should address requirements such as, but not limited to, grading, dust suppressant mechanisms, drainage (where required), signage, and speed limits. The Road Maintenance Plan must ensure regular maintenance of the roads. The Road Maintenance Plan must be communicated with the relevant authorities, where required, and must be provided to the surrounding community forum prior to commencement of construction. 	<ul style="list-style-type: none"> Ensure that the plan is compiled and submitted prior to commencement. Verify that this has been undertaken by reviewing approved plans. 	<ul style="list-style-type: none"> Once-off during the planning and design phase Once-off during the planning and design phase. 	<ul style="list-style-type: none"> Project Developer, Traffic Specialist and Contractor ECO
B. CONSTRUCTION PHASE					
<ul style="list-style-type: none"> Increased traffic generation during the construction phase resulting in a reduction of road based level of service and potential congestion and delays on the surrounding road network. 	Plan the project to spread and reduce the amount of road based traffic during the construction phase.	<ul style="list-style-type: none"> Plan and stagger delivery trips and schedule deliveries so that they occur outside of peak traffic periods, where possible. 	<ul style="list-style-type: none"> Monitor and management of traffic generated and when trips are made. 	<ul style="list-style-type: none"> During construction 	<ul style="list-style-type: none"> Contractor and ECO
		<ul style="list-style-type: none"> Suitable parking areas should be designated for construction trucks and vehicles at the construction site camp in order to promote order and improve safety. 	<ul style="list-style-type: none"> Monitor the placement of the designated parking area for trucks and vehicles via visual inspections and record and report any non-compliance. 	<ul style="list-style-type: none"> Once-off prior to construction and as required during the construction phase. 	<ul style="list-style-type: none"> Project Developer and ECO
		<ul style="list-style-type: none"> The use of public transport (buses and/or minibus taxis) to convey construction personnel to the site should be encouraged. Staff trips should occur outside of peak hours, where possible. 	<ul style="list-style-type: none"> Contractor should record the arrival and departure times as well as the number of workers using public transport. 	<ul style="list-style-type: none"> Once a month on a randomly selected day. 	<ul style="list-style-type: none"> Appointed Contractor

Impact	Mitigation/Management Objectives	Mitigation/Management Actions	Monitoring		
			Methodology	Frequency	Responsibility
		<ul style="list-style-type: none"> Ensure that the existing island removal at the intersection of TR38/01 and DR3093 is undertaken in an environmental conscious manner, once the relevant authorisations from the road authorities are obtained. Ensure that construction vehicles always remain within a demarcated area at the intersection, and that local road officials are informed of the planned island removal process. 	<ul style="list-style-type: none"> Monitor the island removal process via visual inspections and record and report any non-compliance. 	<ul style="list-style-type: none"> As required during the construction phase. 	<ul style="list-style-type: none"> Project Developer and ECO
<ul style="list-style-type: none"> Increased level of road accidents (involving pedestrians, animals, other motorists on the surrounding road network) due to increased traffic during construction. 	<p>Minimise the impact of the construction activities on the local traffic and avoid accidents with pedestrians, animals and other drivers on the surrounding roads.</p> <p>Reduce number of road accidents due to increased traffic during construction.</p>	<ul style="list-style-type: none"> Well maintained vehicles should be used together with well-trained drivers during the construction phase. Vehicle maintenance and driver competency should be monitored. Proof of driver competency as well as the vehicle checks should be verified and undertaken to ensure that vehicles are roadworthy and hence, do not pose a safety risk. The Contractors must ensure that construction vehicles are roadworthy, visible, adequately marked, properly serviced and maintained, operated by an appropriately licensed operator, and respect the vehicle safety standards implemented by the Project Developer. 	<ul style="list-style-type: none"> Carry out random checks of driver licenses and conduct random visual inspections of construction vehicles for roadworthiness. 	<ul style="list-style-type: none"> Random visual inspection of vehicles weekly. 	<ul style="list-style-type: none"> Contractor
		<ul style="list-style-type: none"> To ensure reduced speeds along the roads, implement speed control mechanisms within the construction site by means of a stop and go system, implement speed limits and placement of road signage for the speed limits. 	<ul style="list-style-type: none"> Implement speed control mechanisms within the construction site prior to commencement of construction. Carry out random inspections to verify whether proper speed control is being implemented. 	<ul style="list-style-type: none"> On-going Random during the construction phase 	<ul style="list-style-type: none"> Contractor and ECO ECO
		<ul style="list-style-type: none"> Adhere to all speed limits applicable to all roads used. 	<ul style="list-style-type: none"> Ensure that speed limits are adhered to. Carry out random visual inspections to verify speed limits and general awareness of vehicle drivers. 	<ul style="list-style-type: none"> Daily Random during the construction phase 	<ul style="list-style-type: none"> Contractor and ECO ECO

Impact	Mitigation/Management Objectives	Mitigation/Management Actions	Monitoring		
			Methodology	Frequency	Responsibility
		<ul style="list-style-type: none"> Road kill monitoring programme (inclusive of wildlife collisions record keeping) should be established. 	<ul style="list-style-type: none"> Appropriate monitoring should be undertaken. 	<ul style="list-style-type: none"> Weekly 	<ul style="list-style-type: none"> Contractor and ECO
		<ul style="list-style-type: none"> Implement clear and visible signage indicating movement of vehicles at intersections within the construction site and in the vicinity of the nearby farm steads. 	<ul style="list-style-type: none"> Implement clear signalisation. Carry out random inspections to verify whether proper construction signage is being implemented. 	<ul style="list-style-type: none"> On-going Random during the construction phase 	<ul style="list-style-type: none"> Contractor and ECO ECO
<ul style="list-style-type: none"> Deterioration in the surface condition of the roads and accelerated degradation of road structure due to construction traffic. 	Limit the deterioration of the road condition due to construction traffic.	<ul style="list-style-type: none"> Ensure that there is regular maintenance of the internal farm access roads (i.e. internal private roads leading off the DR3093) that will be used, by the contractor during the construction phase in line with the agreed maintenance plan. Ensure that the upgrading of the internal farm access roads (i.e. internal private roads leading off the DR3093 that are impacted on by the proposed project and will be used), is undertaken to suitable standards as specified by the civil engineer and in accordance with the maintenance plan. Ensure that the internal farm access roads (i.e. internal private roads leading off the DR3093 that are impacted on by the proposed project and will be used) are restored to its original pre-construction road condition. 	<ul style="list-style-type: none"> Carry out visual inspections to verify if regular maintenance is being undertaken. Ensure that the internal farm access road to site is upgraded through photographic surveys and monitoring. 	<ul style="list-style-type: none"> Bi-monthly Ongoing 	<ul style="list-style-type: none"> Contractor and ECO Project Developer, Contractor and ECO
		<ul style="list-style-type: none"> Construction activities will have a higher impact than the normal road activity and therefore the internal farm access roads (i.e. internal private roads leading off the DR3093) to site should be inspected on a weekly basis for structural damage. 	<ul style="list-style-type: none"> Ensure that the access road to site maintains current condition through photographic surveys and monitoring. 	<ul style="list-style-type: none"> Weekly 	<ul style="list-style-type: none"> Contractor and ECO
		<ul style="list-style-type: none"> Implement management strategies for dust generation e.g. apply dust suppressant on the gravel roads on the construction site, exposed areas and stockpiles. Avoid the use of potable water for dust suppression during the 	<ul style="list-style-type: none"> Ensure dust management measures are in place to adequately decrease the generation of dust. 	<ul style="list-style-type: none"> On-going 	<ul style="list-style-type: none"> Contractor and ECO

Impact	Mitigation/Management Objectives	Mitigation/Management Actions	Monitoring		
			Methodology	Frequency	Responsibility
		<p>construction phase and consider the use of alternative approved sources, where possible.</p> <ul style="list-style-type: none"> Vehicles must not be overloaded during the construction phase in order to reduce impacts on the road structures, particularly the access roads leading to the site. Random visual inspection of vehicles should be undertaken in order to monitor for overloading. The inspections should also verify if the trucks are covered with appropriate material (such as tarpaulin) if and where possible. 	<ul style="list-style-type: none"> Perform visual inspection of vehicles during the construction phase. 	<ul style="list-style-type: none"> Random visual inspection of vehicles weekly. 	<ul style="list-style-type: none"> Appointed Contractor
<ul style="list-style-type: none"> Impact on air quality due to dust generation, noise and exhaust emissions from construction vehicles and equipment. 	<p>Limit the release of noise, pollutants and dust emissions</p>	<ul style="list-style-type: none"> Implement management strategies for dust generation e.g. apply dust suppressant on the gravel roads on the construction site, exposed areas and stockpiles. Avoid the use of potable water for dust suppression during the construction phase and consider the use of alternative approved sources, where possible. 	<ul style="list-style-type: none"> Ensure dust management measures are in place to adequately decrease the generation of dust. 	<ul style="list-style-type: none"> On-going 	<ul style="list-style-type: none"> Contractor and ECO
		<ul style="list-style-type: none"> Postpone or reduce dust-generating activities during periods with strong wind. Earthworks may need to be rescheduled or the frequency of application of dust control/suppressant increased. 	<ul style="list-style-type: none"> Ensure dust management measures are in place to decrease the dust generated. 	<ul style="list-style-type: none"> On-going 	<ul style="list-style-type: none"> Contractor and ECO
		<ul style="list-style-type: none"> Avoid using old and unmaintained construction equipment (which generate high sound levels and greater exhaust emissions) and ensure equipment is well maintained. 	<ul style="list-style-type: none"> Manage noise levels and air pollutants from construction vehicles through checking the condition of vehicles. 	<ul style="list-style-type: none"> On-going 	<ul style="list-style-type: none"> Contractor and ECO
C. OPERATIONAL PHASE					
<ul style="list-style-type: none"> Increased level of road accidents (involving pedestrians, animals, other motorists on the surrounding tarred/gravel road network) due to increased (but 	<p>Minimise the impact of the operational activities on the local traffic and avoid accidents with pedestrians, animals and other drivers on</p>	<ul style="list-style-type: none"> Well maintained vehicles should be used together with well-trained drivers during the operational phase, as required. Vehicle maintenance and driver competency should be monitored. Proof of driver competency as well as the vehicle checks should be verified and undertaken to ensure that vehicles are 	<ul style="list-style-type: none"> Carry out random checks of driver licenses and conduct random visual inspections of vehicles for roadworthiness. 	<ul style="list-style-type: none"> Random visual inspection of vehicles weekly. 	<ul style="list-style-type: none"> Project Developer

Impact	Mitigation/Management Objectives	Mitigation/Management Actions	Monitoring		
			Methodology	Frequency	Responsibility
limited) traffic during the operational phase.	the surrounding tarred/ gravel roads. Reduce number of road accidents due to increased traffic during the operational phase.	roadworthy and hence, do not pose a safety risk. Vehicles must be roadworthy, visible, adequately marked, properly serviced and maintained, and operated by an appropriately licensed operator.			
		<ul style="list-style-type: none"> Adhere to all speed limits applicable to all roads used. 	<ul style="list-style-type: none"> Ensure that speed limits are adhered to. Carry out random visual inspections to verify speed limits and general awareness of vehicle drivers. 	<ul style="list-style-type: none"> Daily Random during the operational phase 	<ul style="list-style-type: none"> Project Developer
		<ul style="list-style-type: none"> Implement clear and visible signage indicating movement of vehicles at intersections and in the vicinity of the nearby farm steads. 	<ul style="list-style-type: none"> Implement clear signalisation. Carry out random inspections to verify whether proper signage is being implemented. 	<ul style="list-style-type: none"> Ongoing Random during the operational phase 	<ul style="list-style-type: none"> Project Developer
		<ul style="list-style-type: none"> The use of public transport (buses and/or minibus taxis) or carpooling to convey operational personnel to the site should be encouraged. Staff trips should occur outside of peak hours, where possible. 	<ul style="list-style-type: none"> Monitor the requirements 	<ul style="list-style-type: none"> On-going 	<ul style="list-style-type: none"> Project Developer
		<ul style="list-style-type: none"> Limit access to the site to operational personnel. 	<ul style="list-style-type: none"> Maintain a register of visitors and staff that enter site and restrict access to personnel. 	<ul style="list-style-type: none"> On-going 	<ul style="list-style-type: none"> Project Developer
<ul style="list-style-type: none"> Accelerated degradation of road structure due to operational traffic. 	Limit the deterioration of the road condition due to operational phase traffic.	<ul style="list-style-type: none"> The main access roads to site should be inspected on a weekly basis for structural damage. 	<ul style="list-style-type: none"> Ensure that the main access road to site maintains current condition through photographic surveys and monitoring. 	<ul style="list-style-type: none"> Weekly 	<ul style="list-style-type: none"> Project Developer
		<ul style="list-style-type: none"> Ensure that there is regular maintenance of the internal farm access roads (i.e. internal private roads leading off the DR3093) that will be used, by the operator during the operational phase in line with the agreed maintenance plan. 	<ul style="list-style-type: none"> Carry out visual inspections to verify if regular maintenance is being undertaken. Ensure that the internal farm access road to site is upgraded through 	<ul style="list-style-type: none"> Weekly 	<ul style="list-style-type: none"> Project Developer

Impact	Mitigation/Management Objectives	Mitigation/Management Actions	Monitoring		
			Methodology	Frequency	Responsibility
			photographic surveys and monitoring.		
		<ul style="list-style-type: none"> Implement management strategies for dust generation e.g. apply dust suppressant on gravel roads on the operational site, exposed areas and stockpiles. 	<ul style="list-style-type: none"> Ensure dust management measures are in place to adequately decrease the generation of dust. 	<ul style="list-style-type: none"> On-going 	<ul style="list-style-type: none"> Project Developer
		<ul style="list-style-type: none"> Vehicles must not be overloaded during the operational phase (where applicable) in order to reduce impacts on the road structures. Random visual inspection of vehicles should be undertaken in order to monitor for overloading (where applicable). 	<ul style="list-style-type: none"> Perform visual inspection of vehicles. 	<ul style="list-style-type: none"> Random visual inspection of vehicles weekly. 	<ul style="list-style-type: none"> Project Developer
D. DECOMMISSIONING PHASE					
<ul style="list-style-type: none"> Ensure that the construction mitigation and management measures are adhered to during the decommissioning phase. 					

14.13 Final Specialist Statement and Authorisation Recommendation

14.13.1 Statement and Reasoned Opinion

This report summarises the existing transportation conditions within the site vicinity and provides an assessment of the transportation impacts of the proposed development on the surrounding transport system. From the traffic impact investigation and discussions in the report the following conclusions can be made:

- The preferred route for the haulage of imported materials is from the Port of Ngqura to the site.
- The preferred access route option to the proposed facility will be from the R48 along DR3093, DR3084, and DR3096 gravel roads (i.e. Access Route Option 1). As noted above, Access Route Option 1 - Route A (along TR38/01, DR3093, and DR3096) will provide access to all the proposed Kudu Solar Facilities. Alternatively, once the internal roads are constructed at Kudu Solar Facility 5, it can also be used to access Kudu Solar Facilities 1 to 4. Furthermore, once the internal roads are constructed at Kudu Solar Facility 7, it can also be used to access Kudu Solar Facilities 8 to 12. Access Route Option 1 - Route B (Along TR38/01, DR3093 and DR3084) will provide access to the proposed Kudu Solar Facilities 1 to 5.
- Sufficient shoulder sight distances (SSD) are available along the R48 at the DR3093 in both directions.
- Direct access to the proposed development will be taken off DR3093.
- It is not anticipated that any widening of the intersection at TR38/01 and DR3093 will be required, however, the existing island will need to be removed (approximately 60m²) to accommodate the turning movements of the abnormal load vehicles.
- Based on the wheel tracking analysis of the abnormal load vehicles, it can be concluded that no road will need to be lengthened by more than 1 kilometre for Access Route Option 1.
- Temporary counting stations recorded the ADT in 2011 as 62 vehicles (two-way) along DR3093 and as 8 vehicles (two-way) along DR3084 per day.
-
- If these volumes are increased by a growth rate of 2% per annum, this would relate to the ADT in 2023 as 79 vehicles (two-way) along DR3093 and as 10 vehicles (two-way) along DR3084 per day.
- Traffic information for 2021 indicated that the R389 carries an ADT of 626 vpd (two-way) and the R48 carries an ADT of 866 vpd (two-way).
- The R389 and the R48 operates well below the capacity of 2000 vehicles per hour for a Class 1 principal arterial with two lanes.
- Traffic will be generated during the Construction, Operational and Decommissioning phases of the project.
- During the Construction and Decommissioning phases, an additional **58 daily trips (two-way)** and **4 peak hour trips (two-way)** will be generated by the proposed solar PV facility.
- During the Operation phases, an additional **16 daily trips (two-way)** and **1 peak hour trip (two-way)** will be generated by the proposed solar PV facility.
- The following traffic impacts are related to the trips generated during the Construction and Decommissioning phases:
 - Potential congestion and delays on the surrounding road network.

- Potential impact on traffic safety and increase in accidents with other vehicles or animals.
- Potential change in the quality of the surface condition of the roads.
- Potential noise and dust pollution.
- Traffic generated during the Operational phase will have an insignificant traffic impact on the surrounding road network.
- The proposed project will have a range of potential traffic related impacts ranging from very low to moderate significance before mitigation, which is expected to be reduced to very low to low significance with the appropriate mitigation. No fatal flaws were discovered during the investigations. The proposed project is supported, and it is therefore recommended that the activity is authorised, with the understanding that all mitigation measures recommended in this report will be strictly implemented.

14.13.2 EA Condition Recommendations

The following mitigation measures to address the potential traffic impacts are recommended for inclusion in the EMPr and EA conditions:

- Implement dust control of the gravel roads within the construction site.
- Undertake regular maintenance of the internal farm access roads by the contractor during the construction and decommissioning phases and then by the operator during the operational phase.
- Removal of the island at the TR38/01 and DR3093 intersection to accommodate the turning movements of the abnormal load vehicles.
- Upgrading of the internal farm access road (i.e. internal private roads leading off DR3093 that are impacted on by the proposed project) to suitable standards as specified by the civil engineer and regular maintenance of these access roads during all phases of the project, especially during the construction and decommissioning phases. Following construction, these specific internal private access roads should be restored to original pre-construction road condition.
- Implement speed control by means of a stop and go system and speed limit road signage within the construction site.
- Ensure all vehicles are roadworthy, visible, adequately marked and operated by an appropriately licensed operator.
- The route to the site should be further investigated to ensure that the abnormal loads are not obstructed at any point by geometric, height and width limitations along the route.
- The applicable permits to transport the abnormal loads should be obtained.
- Stagger delivery trips and schedule deliveries/trips outside of the peak traffic periods, where possible.
- Staff trips should also occur outside of the peak hours where possible.

No other remedial or mitigation measures will be required to accommodate the additional traffic generated by the proposed Solar PV Facility. Provided that the above recommendations are adhered to, the proposed development of the Solar PV facility can be supported from a traffic engineering perspective.

14.14 References

- Department of Transport, Guidelines for Traffic Impact Studies, Report No. PR93/645, Pretoria, 1995.
- Department of Transport, South African Trip Generation Rates, Report No. RR92/228, Pretoria, 1995.
- Committee of Transport Officials (COTO), South African Trip Data Manual, TMH 17, Committee Draft 2.2, August 2020.
- Committee of Transport Officials (COTO), South African Traffic Impact and Site Traffic Assessment Manual Standards and Requirements Manual, Volume 2 TMH 16, Committee Draft 2.0, October 2020.
- Committee of Transport Officials (COTO), South African Traffic Impact and Site Traffic Assessment Manual, Volume 1 TMH 16, Committee Draft 2.0, May 2018.
- SANRAL Geometric Design Guide
- Department of Transport, TRH17, Geometric Design of Rural Roads, 1988

APPENDICES

Appendix A - Specialist Expertise



CURRICULUM VITAE

ANNEBET KRIGE

GENERAL INFORMATION:

Name	:	ANNEBET KRIGE
Date of Birth	:	20 November 1984
Marital Status	:	Married
Home Language	:	Afrikaans
Profession	:	Civil Engineer
Specialism	:	Transport Planning and Traffic Engineering
Joined Sturgeon	:	2018
Nationality	:	South African
Years' Experience	:	15+
Qualifications	:	M Eng (Transportation), B Eng (Civil)
Professional Associations	:	Engineering Council of South Africa (ECSA): Professional Engineer (20150161) South African Institution of Civil Engineering (SAICE): Member (206324)



KEY EXPERTISE:

AnneBet Krige is registered as a Professional Civil Engineer with the Engineering Council of South Africa (ECSA). Over the past 15 years, she has gained extensive knowledge in the Civil Engineering field and currently works as a Traffic Engineer for Sturgeon Consulting. She obtained her Masters' Degree in Transportation Engineering from the University of Stellenbosch in 2010 and specialises in this field.

Expertise & Specialised Skills:

AnneBet has gained extensive experience in the following fields:

- Traffic Studies and Transportation Planning (Statements, Assessments, Parking Studies);
- Design of Non-Motorised Transport Facilities;
- Design and Upgrading of Traffic Signals;
- Traffic Accommodation Plans;
- Design of Civil Engineering Infrastructure for various developments (Water, Sewerage, Stormwater, Roads);
- Rehabilitation and Reseal of existing National and Provincial Roads;
- Construction of new Roads;
- Tender Documentation.
- Contract Administration

EMPLOYMENT RECORD:

2021 - Present	Director, Sturgeon Consulting
2018 - 2021	Associate, Sturgeon Consulting
2011 - 2018	Traffic Engineer, Element Consulting Engineers
2006 - 2011	Engineer in Training, EFG Engineers

www.sturgeonsa.co.za

STURGEON Consulting (PTY) LTD (Reg No. 2015/059313/07)
Director: A Krige (Pr Eng) | Associate: SJ Larratt (Pr Tech Eng)
7 Waterberg Crescent, Clara Anna Fontein, Durbanville, 7550

October 2022



CURRICULUM VITAE

ANNEBET KRIGE

KEY QUALIFICATIONS/EDUCATION:

2010 : M Eng (Transportation), University of Stellenbosch
 2006 : B Eng (Civil), University of Stellenbosch

PROFESSIONAL AFFILIATIONS

Professional Engineer, Engineering Council of South Africa (ECSA) - 20150161 - 1 May 2015

PROJECT EXPERIENCE - TRANSPORTATION ENGINEERING (TRAFFIC STUDIES)

Bottling Plant Farm Kaaldraai		Normandien Farms
Traffic Impact Study for the proposed Water Bottling Plant, Tulbagh		
Role & Responsibilities:	Traffic Engineer	
Completed/Current: 2021	Study Value: R35 000	
Ceres PV Farms		Veroniva Energy
Traffic Impact Assessment for nine 175MW Solar Photo Voltaic Farms, Tankwa Karoo		
Role & Responsibilities:	Traffic Engineer	
Completed/Current: 2021	Study Value: R57 000	
Mamre Service Station		Plan Africa Consulting
Traffic Impact Assessment for the proposed Rezoning of Erf 615, Mamre		
Role & Responsibilities:	Traffic Engineer	
Completed/Current: 2019	Study Value: R34 700	
Langebaanweg Truck Stop		West Coast Petroleum (Pty) Ltd
Access Investigation / Traffic Impact Assessment for the proposed Langebaanweg Truck Stop		
Role & Responsibilities:	Traffic Engineer	
Completed/Current: 2020	Study Value: R89 800	
Abbotsdale		CK Rumboll and Partners
Traffic Impact Assessment for the Industrial Development on Portion A of Erf 373, Abbotsdale		
Role & Responsibilities:	Traffic Engineer	
Completed/Current: 2019	Study Value: R60 100	
Grootfontein - Tsumkwe Feasibility Study		Pregon Consulting Engineers
Feasibility Study for the Upgrade to Bitumen Standard of M0074: Grootfontein - Tsumkwe		
Role & Responsibilities:	Traffic Engineer	
Completed/Current: Current	Study Value: R163 600	
Sleeper Site, East London		
Traffic Study for the Development of the Sleeper Site, East London		
Role & Responsibilities:	Traffic Engineer	
Completed/Current: 2017	Study Value: R255 000	
Worcester Traffic Study		
Traffic Study at Pre-Determined intersections in Worcester		
Role & Responsibilities:	Traffic Engineer	
Completed/Current: 2017	Project Value: R537 000	



CURRICULUM VITAE

ANNEBET KRIGE

PV Farm Hanover	
Traffic Impact Statement for the Proposed Solar PV Farm, Hanover	
Role & Responsibilities:	Traffic Engineer
Completed/Current: 2017	Study Value: R38 500
Malmesbury Sand Mine	
Tip Trans Logistix Traffic Impact Statement for a Sand Mine, Malmesbury	
Role & Responsibilities:	Traffic Engineer
Completed/Current: 2017	Study Value: R24 500
Strand Storage Facilities	
Asla Devco Traffic Impact Study for the proposed Storage and Office Facilities in Strand	
Role & Responsibilities:	Traffic Engineer
Completed/Current: 2017	Study Value: R33 500
Dube Tradeport	
Dube Tradeport Traffic Impact Study for Dube Tradeport, Durban	
Role & Responsibilities:	Traffic Engineer
Completed/Current: Current	Study Value: R80 000

PROJECT EXPERIENCE - GENERAL TRANSPORTATION ENGINEERING

Bonnievale Speed Survey		WCG
Speed Limit Survey for TR32/1, Bonnievale		
Role & Responsibilities:	Traffic Engineer	
Completed/Current: 2021	Study Value: R70 000	
Road Safety Audit		Namibia Roads Authority
Road Safety Audit for T0602: Gobabis to Buitepos		
Role & Responsibilities:	Traffic Engineer	
Completed/Current: 2016	Contract Value:	
Non-Motorised Transport, City of Cape Town		City of Cape Town
Implementation of the Non-Motorised Transport programme to the City of Cape Town		
Role & Responsibilities:	Traffic Engineer	
Completed/Current: 2016	Contract Value: R50m	
Westbury Pedestrian Bridge, Johannesburg		Johannesburg Development Agency
Traffic Accommodation Plan for the construction of the Westbury Pedestrian Bridge, Johannesburg		
Role & Responsibilities:	Traffic Engineer	
Completed/Current: 2014	Contract Value: Unknown	
Erven 13259 and 13585, Brackenfell		Group 5 Property Development
Traffic Accommodation Plan for the development of Erven 13259 and 13585, Brackenfell		
Role & Responsibilities:	Traffic Engineer	
Completed/Current: 2014	Contract Value: R550 000	
Lakeview and Klipspruit BRT Stations, Soweto		Johannesburg Roads Authority
Non-motorised Transport for Lakeview and Klipspruit BRT Stations, Soweto		
Role & Responsibilities:	Traffic Engineer / Design Engineer	
Completed/Current: 2014	Contract Value: R35 million	



CURRICULUM VITAE

ANNEBET KRIGE

PROJECT EXPERIENCE – REHABILITATION / RESEAL / NEW ROAD CONSTRUCTION

Upgrading of Medway Road, Richards Bay	
Upgrading of Medway Road	
Role & Responsibilities:	Assistant Engineer
Completed/Current: Current	Contract Value: R50 million
Trunk Road 32 between N2 and Herbertsdale	
Provincial Government Western Cape The Reseal / Rehabilitation of a section of Main Road 342 between km 7.72 and Herbertsdale	
Role & Responsibilities:	Assistant Engineer
Completed/Current: Current	Contract Value: Unknown
National Route 7, Garies	
SANRAL Repair and Reseal of National Route 7 Section 7 between Garies and km 60	
Role & Responsibilities:	Assistant Engineer
Completed/Current: Current	Contract Value: R101.4 million
National Route 7, Okiep	
SANRAL Repair and Reseal of National Route 7 Section 7 to 8 between km 60 and Okiep	
Role & Responsibilities:	Assistant Engineer
Completed/Current: Current	Contract Value: R95.5 million
Roads P122/1, P249/1, P39/1, P241/1(D405) and K111, Muldersdrift	
Rehabilitation of Roads P122/1, P249/1, P39/1, P241/1(D405) and K111, Muldersdrift	
Role & Responsibilities:	Assistant Engineer
Completed/Current: Current	Contract Value: Unknown
Trunk Road 32 between Ashton and Swellendam	
Provincial Government Western Cape The Reseal of Trunk Road 32 Section 1 between Ashton and Swellendam, Main Road 283 and Divisional Road 1329	
Role & Responsibilities:	Assistant Engineer
Completed/Current: 2014	Contract Value: R60.8 million
National Route 14 Section 1 between Witputs and Pofadder	
SANRAL Repair and reseal N14 between Witputs and Pofadder	
Role & Responsibilities:	Assistant Engineer
Completed/Current: 2013	Contract Value: R70.3 million
National Route 14 Section 2 between Bladgrond and Kakamas	
Repair and reseal: National route 14 Section 2 between Bladgrond (Km 59.00) and Kakamas 9Km 131.00)	
Role & Responsibilities:	Assistant Engineer
Completed/Current: 2014	Contract Value: R89.1 million

PROJECT EXPERIENCE: CIVIL INFRASTRUCTURE

Sitari, Somerset West	
Civil Engineering Services for Sitari Fields, Somerset West	
Role & Responsibilities:	Assistant Resident Engineer
Completed/Current: Current	Contract Value: R350m
Van der Stel, Stellenbosch	
Upgrading of the Van der Stel Sport Complex parking area	
Role & Responsibilities:	Resident Engineer
Completed/Current: 2012	Contract Value: R700 000



CURRICULUM VITAE

ANNEBET KRIGE

CSP Plant, Upington	
Access to the proposed CSP Plant	
Role & Responsibilities:	Design Engineer
Completed/Current: 2012	Contract Value: Unknown
Droogfontein, Kimberley	
Upgrading of the existing access to the proposed PV Farm, Droogfontein, Kimberley	
Role & Responsibilities:	Design Engineer
Completed/Current: 2012	Contract Value: Unknown
Robben Island	
Repair & Maintenance of Water and Sewerage works on Robben Island	
Role & Responsibilities:	Assistant Resident Engineer
Completed/Current: 2011	Contract Value: R12 million
KFC Observatory	
Civil Engineering Services for KFC, Observatory	
Role & Responsibilities:	Assistant Resident Engineer
Completed/Current: 2010	Contract Value: R300 000
Blue Downs Development	
Upgrading of Roads and Accesses for the Blue Downs Development	
Role & Responsibilities:	Assistant Design Engineer
Completed/Current: 2010	Contract Value: R12 million
Shoprite, Strand	
Construction of Broadway Shoprite Access Road, Strand	
Role & Responsibilities:	Resident Engineer
Completed/Current: 2010	Contract Value: R950 000
Checkers, Burgundy	
Civil Infrastructure for Checkers, Burgundy Estate	
Role & Responsibilities:	Assistant Design Engineer, Assistant Resident Engineer
Completed/Current: 2009	Contract Value: R44 million

Appendix B - Specialist Statement of Independence



environmental affairs

Department:
 Environmental Affairs
 REPUBLIC OF SOUTH AFRICA

DETAILS OF THE SPECIALIST, DECLARATION OF INTEREST
 AND UNDERTAKING UNDER OATH

File Reference Number:	(For official use only)
NEAS Reference Number:	DEA/EIA/
Date Received:	

Application for authorisation in terms of the National Environmental Management Act, Act No. 107 of 1998, as amended
 and the Environmental Impact Assessment (EIA) Regulations, 2014, as amended (the Regulations)

PROJECT TITLE

Scoping and Environmental Impact Assessment Processes for the Proposed Development of 12 Solar Photovoltaic (PV) Facilities and associated infrastructure (i.e. Kudu Solar Facility 1 - 12), near De Aar, Northern Cape

Kindly note the following:

1. This form must always be used for applications that must be subjected to Basic Assessment or Scoping & Environmental Impact Reporting where this Department is the Competent Authority.
2. This form is current as of 01 September 2018. It is the responsibility of the Applicant / Environmental Assessment Practitioner (EAP) to ascertain whether subsequent versions of the form have been published or produced by the Competent Authority. The latest available Departmental templates are available at <https://www.environment.gov.za/documents/forms>.
3. A copy of this form containing original signatures must be appended to all Draft and Final Reports submitted to the department for consideration.
4. All documentation delivered to the physical address contained in this form must be delivered during the official Departmental Officer Hours which is visible on the Departmental gate.
5. All EIA related documents (includes application forms, reports or any EIA related submissions) that are faxed; emailed; delivered to Security or placed in the Departmental Tender Box will not be accepted, only hardcopy submissions are accepted.

Departmental Details

<p>Postal address: Department of Environmental Affairs Attention: Chief Director: Integrated Environmental Authorisations Private Bag X447 Pretoria 0001</p> <p>Physical address: Department of Environmental Affairs Attention: Chief Director: Integrated Environmental Authorisations Environment House 473 Steve Biko Road Arcadia</p> <p>Queries must be directed to the Directorate: Coordination, Strategic Planning and Support at: Email: EIAAdmin@environment.gov.za</p>

1. SPECIALIST INFORMATION

Specialist Company Name:	Sturgeon Consulting		
B-BBEE	Contribution level (indicate 1 to 8 or non-compliant)	Non-Compliant	Percentage Procurement recognition
Specialist name:	Annebet Krige		
Specialist Qualifications:	M. Eng (Transportation) – Stellenbosch University 2010 B. Eng (Civil) – Stellenbosch University 2006		
Professional affiliation/registration:	Engineering Council of South Africa (ECSA) Registration Number: 20150161		
Physical address:	7 Waterberg Crescent, Clara Anna Fontein, Durbanville, Cape Town		
Postal address:			
Postal code:	7550	Cell:	084 610 0233
Telephone:		Fax:	
E-mail:	Annebet@sturgesa.co.za		

2. DECLARATION BY THE SPECIALIST

I, _____ Annebet Krige _____, declare that –

- I act as the independent specialist in this application;
- I will perform the work relating to the application in an objective manner, even if this results in views and findings that are not favourable to the applicant;
- I declare that there are no circumstances that may compromise my objectivity in performing such work;
- I have expertise in conducting the specialist report relevant to this application, including knowledge of the Act, Regulations and any guidelines that have relevance to the proposed activity;
- I will comply with the Act, Regulations and all other applicable legislation;
- I have no, and will not engage in, conflicting interests in the undertaking of the activity;
- I undertake to disclose to the applicant and the competent authority all material information in my possession that reasonably has or may have the potential of influencing - any decision to be taken with respect to the application by the competent authority; and - the objectivity of any report, plan or document to be prepared by myself for submission to the competent authority;
- all the particulars furnished by me in this form are true and correct; and
- I realise that a false declaration is an offence in terms of regulation 48 and is punishable in terms of section 24F of the Act.



Signature of the Specialist

Sturgeon Consulting

Name of Company:

5 July 2023

Date

Details of Specialist, Declaration and Undertaking Under Oath

3. UNDERTAKING UNDER OATH/ AFFIRMATION

I, _____ Annebel Krige _____, swear under oath / affirm that all the information submitted
or to be submitted for the purposes of this application is true and correct.



Signature of the Specialist

Sturgeon Consulting

Name of Company

5 July 2023

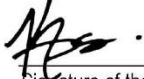

Date



Signature of the Commissioner of Oaths

06 July 2023

Date

.....
 **SABPP**TM
SA BOARD FOR
PEOPLE PRACTICES
Setting HR standards
KERRY AUGUST
Commissioner of Oaths
Master HR Professional (MHRP)
Member Number: 53544596
25 Bordeaux Close
Stellenbosch
7600

Appendix C: Site Sensitivity Verification

It is important to note that there are no dedicated traffic or transport related themes on the National Web-based Environmental Screening Tool (Screening Tool), therefore the environmental sensitivity of the proposed project area as identified by the Screening Tool is not applicable. Therefore, no site sensitivity verification report is required. Furthermore, there is no dedicated assessment protocol prescribed for Traffic. Therefore, the specialist assessment has been undertaken in compliance with Appendix 6 of the NEMA EIA Regulations of 2014.

Appendix D: Impact Assessment Methodology

The impact assessment includes:

- *the nature, status, significance and consequences of the impact and risk;*
- *the extent and duration of the impact and risk;*
- *the probability of the impact and risk occurring;*
- *the degree to which impacts and risks can be mitigated;*
- *the degree to which the impacts and risks can be reversed; and*
- *the degree to which the impacts and risks can cause loss of irreplaceable resources.*

Terminology used in impact assessment can overlap. To avoid ambiguity, please note the following clarifications (that are based on NEMA and the EIA Regulations):

- *The term environment is understood to have a broad interpretation that includes both the natural (biophysical) environment and the socio-economic environment. The term socio-ecological system is also used to describe the natural and socio-economic environment and the interactions amongst these components.*
- *Significance = Consequence x Probability, which means that significance is equivalent to risk.*
- *The impact can have a positive or negative status. The significance of a negative impact may be called a risk, and the significance of a positive impact may be called an opportunity.*

The following principles are to underpin the application of this methodology:

- *Transparent and repeatable process - specialists are to describe the thresholds and limits they apply in their assessment, wherever possible.*
- *Adapt parameters to context (where justified) – the methodology proposes some thresholds (e.g. for spatial extent, in Step 3 below), however, if the nature of the impact requires a different definition of the categories of spatial extent, then this can be provided and described.*
- *Combination of a quantitative and qualitative assessment – where possible, specialists are to provide quantitative assessments (e.g. areas of habitat affected, decibels of noise, number of jobs), however, it is recognised that not all impacts can be quantified, and then qualitative assessments are to be provided.*

As per the DFFE Guideline 5: Assessment of Alternatives and Impacts, the following methodology is applied to the prediction and assessment of impacts and risks. Potential impacts and risks have been rated in terms of the direct, indirect and cumulative:

- *Direct impacts are impacts that are caused directly by the activity and generally occur at the same time and at the place of the activity. These impacts are usually associated with the construction, operation or maintenance of an activity and are generally obvious and quantifiable.*
- *Indirect impacts of an activity are indirect or induced changes that may occur as a result of the activity. These types of impacts include all the potential impacts that do not manifest immediately when the activity is undertaken or which occur at a different place as a result of the activity.*
- *Cumulative impacts are impacts that result from the incremental impact of the proposed activity on a common resource when added to the impacts of other past, present or reasonably foreseeable future activities. Cumulative impacts can occur from the collective impacts of individual minor actions over a period of time and can include both direct and indirect impacts.*

The impact assessment methodology includes the aspects described below.

- **Step 1: Nature** of impact/risk - *The type of effect that a proposed activity will have on the environment.*
- **Step 2: Status** - *Whether the impact/risk on the overall environment will be:*
 - *Positive - environment overall will benefit from the impact/risk;*
 - *Negative - environment overall will be adversely affected by the impact/risk; or*
 - *Neutral - environment overall not be affected.*
- **Step 3: Qualitatively** determine the **consequence** of the impact/risk by identifying the **a) SPATIAL EXTENT; b) DURATION; c) REVERSIBILITY; AND d) IRREPLACEABILITY.**
 - **A) Spatial extent** – *The size of the area that will be affected by the impact/risk:*
 - *Site specific;*
 - *Local (<10 km from site);*
 - *Regional (<100 km of site);*
 - *National; or*
 - *International (e.g. Greenhouse Gas emissions or migrant birds).*
 - **B) Duration** – *The timeframe during which the impact/risk will be experienced:*
 - *Very short term (instantaneous);*
 - *Short term (less than 1 year);*
 - *Medium term (1 to 10 years);*
 - *Long term (the impact will cease after the operational life of the activity (i.e. the impact or risk will occur for the project duration)); or*
 - *Permanent (mitigation will not occur in such a way or in such a time span that the impact can be considered transient (i.e. the impact will occur beyond the project decommissioning)).*
 - **C) Reversibility** of the Impacts - *the extent to which the impacts/risks are reversible assuming that the project has reached the end of its life cycle (decommissioning phase):*
 - *High reversibility of impacts (impact is highly reversible at end of project life i.e. this is the most favourable assessment for the environment);*
 - *Moderate reversibility of impacts;*
 - *Low reversibility of impacts; or*
 - *Impacts are non-reversible (impact is permanent, i.e. this is the least favourable assessment for the environment).*
 - **D) Irreplaceability** of Receiving Environment/Resource Loss caused by impacts/risks – *the degree to which the impact causes irreplaceable loss of resources assuming that the project has reached the end of its life cycle (decommissioning phase):*
 - *High irreplaceability of resources (project will destroy unique resources that cannot be replaced, i.e. this is the least favourable assessment for the environment);*
 - *Moderate irreplaceability of resources;*
 - *Low irreplaceability of resources; or*

- *Resources are replaceable (the affected resource is easy to replace/rehabilitate, i.e. this is the most favourable assessment for the environment).*

*Some of the criteria are quantitative (e.g. spatial extent and duration) and some may be described in a quantitative or qualitative manner (e.g. reversibility and irreplaceability). The specialist then combines these criteria in a qualitative manner to determine the **consequence**.*

The consequence terms ranging from slight to extreme must be calibrated per Specialist Study so that there is transparency and consistency in the way a risk/impact is measured. For example, from a biodiversity and ecology perspective, the consequence ratings could be defined according to a reduction in population or occupied area in relation to Species of Conservation Concern (SCC) status, ranging from slight consequence for defined areas of Least Concern, to extreme consequence for defined areas that are Critically Endangered. For example, from a social perspective, a slight consequence could refer to small and manageable impacts, or impacts on small sections of the community; a moderate consequence could refer to impacts which affect the bulk of the local population negatively or may produce a net negative impact on the community; and an extreme consequence could refer to impacts which could result in social or political violence or institutional collapse.

- **Consequence** – *The anticipated consequence of the risk/impact is generally defined as follows:*
 - *Extreme (extreme alteration of natural or socio-economic systems, patterns or processes, i.e. where environmental or socio-economic functions and processes are altered such that they permanently cease);*
 - *Severe (severe alteration of natural or socio-economic systems, patterns or processes, i.e. where environmental or socio-economic functions and processes are altered such that they temporarily or permanently cease);*
 - *Substantial (substantial alteration of natural or socio-economic systems, patterns or processes, i.e. where environmental or socio-economic functions and processes are altered such that they temporarily or permanently cease);*
 - *Moderate (notable alteration of natural or socio-economic systems, patterns or processes, i.e. where the natural or socio-economic environment continues to function but in a modified manner; or*
 - *Slight (negligible and transient alteration of natural or socio-economic systems, patterns or processes, i.e. where natural systems/environmental or socio-economic functions, patterns, or processes are not affected in a measurable manner, or if affected, that effect is transient and the system recovers).*
- **Step 4:** *Rate the **probability** of the impact/risk using the criteria below:*
 - **Probability** – *The probability of the impact/risk occurring:*
 - *Extremely unlikely (little to no chance of occurring);*
 - *Very unlikely (<30% chance of occurring);*
 - *Unlikely (30-50% chance of occurring)*
 - *Likely (51 – 90% chance of occurring); or*
 - *Very Likely (>90% chance of occurring regardless of prevention measures).*

- **Step 5:** Use both the **consequence** and **probability** to determine the **significance** of the identified impact/risk (qualitatively as shown in Figure 1). Significance definitions and rankings are provided below:

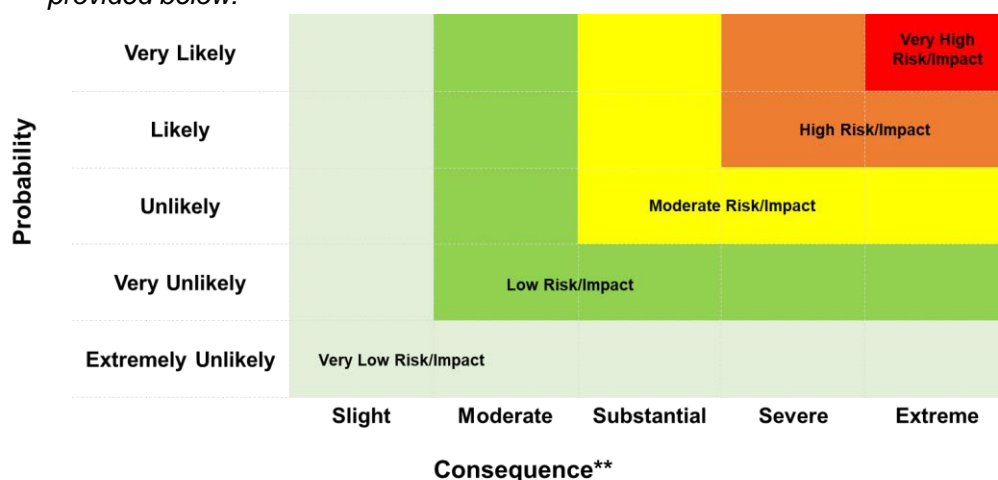

**[Qualitatively determined based on Spatial Extent, Duration, Reversibility and Irreplaceability]

Figure 1. Guide to assessing risk/impact significance as a result of consequence and probability.

- **Significance** – Will the impact cause a notable alteration of the environment?
 - Very low (the risk/impact may result in very minor alterations of the environment and can be easily avoided by implementing appropriate mitigation measures, and will not have an influence on decision-making);
 - Low (the risk/impact may result in minor alterations of the environment and can be easily avoided by implementing appropriate mitigation measures, and will not have an influence on decision-making);
 - Moderate (the risk/impact will result in moderate alteration of the environment and can be reduced or avoided by implementing the appropriate mitigation measures, and will only have an influence on the decision-making if not mitigated);
 - High (the risk/impact will result in major alteration to the environment even with the implementation on the appropriate mitigation measures and will have an influence on decision-making); and
 - Very high (the risk/impact will result in very major alteration to the environment even with the implementation on the appropriate mitigation measures and will have an influence on decision-making (i.e. the project cannot be authorised unless major changes to the engineering design are carried out to reduce the significance rating)).

With the implementation of mitigation measures, the residual impacts/risks are ranked as follows in terms of significance:

- Very low = 5;
- Low = 4;
- Moderate = 3;
- High = 2; and
- Very high = 1.

The specialists must provide a written supporting motivation of the assessment ratings provided.

- **Step 6:** *Determine the **Confidence Level** – The degree of confidence in predictions based on available information and specialist knowledge:*
 - *Low;*
 - *Medium; or*
 - *High.*

Appendix E: Compliance with the Appendix 6 of the 2014 EIA Regulations (as amended)

Requirements of Appendix 6 (Specialist Reports) of Government Notice R326 (Environmental Impact Assessment (EIA) Regulations of 2014, as amended)	Section where this has been addressed in the Specialist Report
1. (1) A specialist report prepared in terms of these Regulations must contain -	Section 14.1.2 and Appendix A and Appendix B of this chapter
a) details of -	
i. the specialist who prepared the report; and	
ii. the expertise of that specialist to compile a specialist report including a curriculum vitae;	Appendix B of this chapter
b) a declaration that the specialist is independent in a form as may be specified by the competent authority;	Section 14.1.1
c) an indication of the scope of, and the purpose for which, the report was prepared;	Section 14.2
(cA) an indication of the quality and age of base data used for the specialist report;	Section 14.4 to Section 14.9
(cB) a description of existing impacts on the site, cumulative impacts of the proposed development and levels of acceptable change;	Section 14.2
d) the duration, date and season of the site investigation and the relevance of the season to the outcome of the assessment;	Section 14.1 and Section 14.2
e) a description of the methodology adopted in preparing the report or carrying out the specialised process inclusive of equipment and modelling used;	Section 14.4
f) details of an assessment of the specific identified sensitivity of the site related to the proposed activity or activities and its associated structures and infrastructure, inclusive of a site plan identifying site alternatives;	N/A
g) an identification of any areas to be avoided, including buffers;	Section 14.4
h) a map superimposing the activity including the associated structures and infrastructure on the environmental sensitivities of the site including areas to be avoided, including buffers;	Section 14.2.2
i) a description of any assumptions made and any uncertainties or gaps in knowledge;	Section 14.4.4.3
j) a description of the findings and potential implications of such findings on the impact of the proposed activity or activities;	Section 14.8 and Section 14.9
k) any mitigation measures for inclusion in the EMPr;	Section 14.8 and Section 14.9
l) any conditions for inclusion in the environmental authorisation;	Section 14.8 and Section 14.9
m) any monitoring requirements for inclusion in the EMPr or environmental authorisation;	Section 14.13.1 Section 14.13.2
n) a reasoned opinion- i. whether the proposed activity, activities or portions thereof should be authorised;	
(iA) regarding the acceptability of the proposed activity or activities; and ii. if the opinion is that the proposed activity, activities or portions thereof should be authorised, any avoidance, management and mitigation measures that should be included in the EMPr, and where applicable, the closure plan;	
o) a description of any consultation process that was undertaken during the course of preparing the specialist report;	N/A
p) a summary and copies of any comments received during any consultation process and where applicable all responses thereto; and	N/A
q) any other information requested by the competent authority.	N/A
(2) Where a government notice by the Minister provides for any protocol or minimum information requirement to be applied to a specialist report, the requirements as indicated in such notice will apply.	Part A of the Assessment Protocols published in GN 320 on 20 March 2020 is

Requirements of Appendix 6 (Specialist Reports) of Government Notice R326 (Environmental Impact Assessment (EIA) Regulations of 2014, as amended)	Section where this has been addressed in the Specialist Report
	<i>applicable (i.e. Site sensitivity verification requirements where a specialist assessment is required but no specific assessment protocol has been prescribed).</i>



CHAPTER 15:

Battery Energy Storage Systems High Level Risk Assessment



**HIGH LEVEL SAFETY HEALTH AND
ENVIRONMENTAL RISK ASSESSMENT FOR
THE DEVELOPMENT OF A
BATTERY ENERGY STORAGE SYSTEM AT THE
PROPOSED SOLAR PHOTOVOLTAIC FACILITY
(KUDU SOLAR FACILITY 7), DE AAR,
NORTHERN CAPE PROVINCE**

28th May 2023

REPORT:	HIGH LEVEL SAFETY HEALTH AND ENVIRONMENTAL RISK ASSESSMENT FOR THE DEVELOPMENT OF A BATTERY ENERGY STORAGE SYSTEM AT THE PROPOSED SOLAR PHOTOVOLTAIC FACILITY (SOLAR KUDU 7) NEAR DE AAR IN THE NORTHERN CAPE
ASSIGNMENT NO:	J3115M - 7
REPORT DATE:	28 th May 2023
RISK ASSESSOR, REPORT:	Debra Mitchell Telephone: 011 201 4783/5 Email: mitcheld@ishecon.co.za
TECHNICAL SIGNATORY:	Debra Mitchell Telephone: 011 201 4783/5 Mobile phone: 082 428 8844 Email: mitchelld@ishecon.co.za
CLIENT:	CSIR on behalf of ABO Renewable Energies (Pty) Ltd
ENVIRONMENTAL ASSESSMENT PRACTITIONER:	Rohaida Abed on behalf of ABO +27 31 242 2318 rabed@csir.co.za
INSTALLATION REPRESENTATIVE	Du Toit Malherbe and Petrus Scheepers ABO (Pty) Ltd
ADDRESS OF INSTALLATION:	Renosterberg Local Municipality in the Pixley ka Seme District Municipality in the Northern Cape
ADDRESS OF COMPANY:	Unit B1, Mayfair Square, Century Way, Century City, 7441, South Africa



ISHECON cc, H4 Pinelands Office Park, Maxwell Drive, Modderfontein, Box 320 Modderfontein 1645
Tel: (011) 201 4785/83 Fax: (086) 549 0878 Cell: (082) 428-8844
Email: mitchelld@ishecon.co.za
CK 99/29022/23 VAT 4800182422

REPORT ADMINISTRATIVE RECORD

LIST OF ASSESSMENTS

Assessment	Rev. No.	Assessment Date	Description
SHE Risk Assessment	2	28 th April 2023	J3115M - 7 – High-Level Safety Health and Environmental Risk Assessment for the Development of a Battery Energy Storage System At The Proposed Solar Photovoltaic Facility (Solar Kudu 7) Near De Aar In The Northern Cape - Issued By Ishecon

CONTRIBUTORS

The validity, results and conclusions of this assessment are based on the expertise, skills and information provided by the following contributing team members:

NAME	ORGANISATION	DISCIPLINE
Rohaida Abed	CSIR	Environmental Consultant
Du Toit Malherbe and Petrus Scheepers	ABO-Wind	Project Manager

DISCLAIMER

Although every effort has been made by ISHECON to obtain the correct information and to carry out an appropriate, independent, impartial and competent study, it remains the responsibility of the Contractor to ensure suitable Process Safety Measures are in place. ISHECON cannot be held liable for any accident or incident, due to negligence by the owner/operator, which directly or indirectly relates to the plant, equipment, facilities and systems analysed in this document and which may have an effect on the client or any other third party.

CONFIDENTIALITY

ISHECON will keep all information, results and findings confidential, and will not pass these on to other parties without the permission of the Client. However, as an Approved Inspection Authority for Department of Employment and Labour, ISHECON is also under legal obligation to the Department of Employment and Labour to report any obvious violations of the OHS Act.

RISK ASSESSMENT APPROVAL

This report is approved for issue by the undersigned Technical Signatory.

NAME	CAPACITY	REPORT DATE	SIGNATURE
D.C. Mitchell	Risk Assessment, Report preparation, Technical signatory	28 th May 2023	

EXECUTIVE SUMMARY

The applicant, Kudu Solar Facility 7 (Pty) Ltd, is considering a Battery Energy Storage Systems (BESS) to complement a solar power (Kudu 7 Photo-voltaic (PV)) generation facility near the town of De Aar in the Northern Cape.

The BESS system will have a power generation capacity of up to 500 MW and will be able to deliver up to 500 MWh. It is proposed that Lithium Battery Technologies, such as Lithium-Ion Phosphate, Lithium Nickel Manganese Cobalt oxides or Redox flow technology, typically vanadium, will be considered as the possible battery technologies, however, the specific technology will only be determined following Engineering, Procurement and Construction (EPC) procurement. The batteries this would typically be housed within numerous containers although the redox flow type could be house in a single building.

Supplementary infrastructure and equipment may include substations, power cables, transformers, power converters, substation buildings & offices, HV/MV switch gear, inverters and other control equipment that may be positioned within the battery containers / separate dedicated containers / the battery building.

The proposed BESS is subject to an Environmental Impact Assessment (S&EIA) process. In 2019, the Department of Forestry, Fisheries and the Environment (DFFE) requested that EIA applications for BESSs, either on their own or as part of a power generation (e.g., PV or wind) application, should include a high-level Risk Assessment of the BESS considering all applicable risks (e.g., fire, explosion, contamination, end-of life disposal etc).

This report summaries the high-level Safety Health and Environmental Risk Assessment conducted by ISHECON for the proposed Solid-State Lithium (SSL) or Vanadium Redox Flow (VRFB) Battery Energy Storage Systems at the proposed Kudu 7 Solar PV facilities.

1. METHODOLOGY

This assessment of risk comprises:

- Identification of the likely hazards and hazardous events related to the construction, operation and decommissioning of the installation using a checklist approach.
- Estimation of the likelihood/probability of these hazardous events occurring.
- Estimation of the consequences of these hazardous events.
- Estimation of the risk and comparison against certain acceptability criteria.

For the purpose of this high-level Risk Assessment a desktop study of the available information, preliminary layout of the facility and associated BESS alternative locations, reports of related incidents and various literature sources was undertaken. The facility and the project were divided into the sections/phases and using a checklist approach the hazards in each section/phase were identified. Each identified hazard was then analysed in terms of causes, consequences, expected and suggested preventive and mitigative measures to be in place. Each hazard was qualitatively assessed using a qualitative risk ranking system.

2. FINDINGS

In order to highlight the maximum differences between the possible technology types, this study is based on the assumption that redox flow batteries (typically vanadium based chemistry) would most likely be installed within a building using bulk tanks, while solid state batteries (typically lithium based chemistry) would be installed in shipping containers that have hundreds of individual batteries combined into packs. Redox flow batteries can be installed in containers where the individual quantities of electrolyte involved would be smaller.

GENERAL

- This Risk Assessment has found that with suitable preventative and mitigative measures in place, none of the identified potential risks are excessively high, i.e., from a Safety, Health and Environment (SHE) perspective no fatal flaws were found with either type of technology for the proposed BESS installation at the Kudu 7 SEF near De Aar.
- At a large facility, without installation of the state-of-the art battery technology that includes protective features, there can be significant risks to employees and first responders. The latest battery designs include many preventative and mitigative measures to reduce these risks to tolerable levels. (Refer to tables in section 4 under preventative and mitigative measures). Where reasonably practicable, state-of-the-art technology should be used, i.e., not old technology that may have been prone to fire and explosion risks.
- The design should be subject to a full Hazard and Operability Study (HAZOP) prior to commencement of procurement. A HAZOP is a detailed technical systematic study that looks at the intricacies of the design, the control system, the emergency system etc. and how these may fail under abnormal operating conditions. Additional safeguards may be suggested by the team doing the study.

LITHIUM SOLID STATE CONTAINERIZED BATTERIES

- With lithium solid-state batteries, the most significant hazard with battery units is the possibility of thermal runaway and the generation of toxic and flammable gases. There have been numerous such incidents around the world with batteries at all scales and modern technology providers include many preventative and mitigative features in their designs. This type of event also generates heat which may possibly propagate the thermal runaway event to neighbouring batteries if suitable state of the art technology is not employed.
- The flammable gases generated may ignite leading to a fire which accelerates the runaway process and may spread the fire to other parts of the BESS or other equipment located near-by.
- If the flammable gases accumulate within the container before they ignite, they may eventually ignite with explosive force. This type of event is unusual but has happened with an older technology container installed at McMicken in the USA in 2019.
- Due to a variety of causes, thermal runaway could happen at any point during transport to the facility, during construction or operation / maintenance at the facility or during decommissioning and safe making for disposal.
- Due to the containerized approach as well as the usual good practice of separation between

containers, which should be applied on this project, and therefore the likely restriction of events to one container at a time, the main risks are close to the containers i.e., to transport drivers, employees at the facilities and first responders to incidents.

- In terms of a worst conceivable case container fires, the significant impact zone is likely to be limited to within 10m of the container and mild impacts to 20m. Based on the current proposed layouts, impacts at the closest isolated farmhouses are not expected.
- In terms of a worst conceivable case explosion, the significant impact zone is likely to be limited to within 10m of the container and minor impacts such as debris within 50m. Based on the current proposed layouts, impacts at the closest isolated farmhouses are not expected.
- In terms of a worst reasonably conceivable toxic smoke scenario, provided the units are placed suitably far apart to prevent propagation from one unit to another and large external fires are prevented, the amount of material burning should be limited to one container at any one time. In this case, beyond the immediate vicinity of the fire, the concentrations of harmful gases within the smoke should be low. The proposed BESS installation's location should ideally be over 500m from any occupied development / farmhouse. The BESS is well over 500m from the closest facility, and therefore the risks posed by BESS are acceptably low.
- Based on the above it is suggested that if the substation were over 20m from the closest BESS container there should be limited direct impacts of any fire or explosion on the substation. With this separation, fires at the substation are also not likely to lead to domino failures of the BESS.

VANADIUM REDOX FLOW BATTERY INSTALLATIONS

- The most significant hazard with VRFB units is the possibility of spills of corrosive and environmentally toxic electrolyte. Many preventative and mitigative features will be included in the design and operation, e.g., full secondary containment, level control on tanks, leak detection on equipment etc. (Refer to tables in section 4 under preventative and mitigative measures).
- VRFB units do not present significant fire and electrical arcing hazards provided they are correctly designed, operated, maintained and managed. Suitable Battery Management System (BMS), safety procedures, operating instructions, maintenance procedures, trips, alarms and interlocks should be in place. (Refer to tables in section 4 under preventative and mitigative measures).

TECHNOLOGY AND LOCATION OF BESS FACILITIES

- From a safety and health point of view, the above Risk Assessment shows that risks posed by VRFB systems may be slightly lower than those of SSL facilities, particularly with respect to fire and explosion risks. From an environmental spill and pollution point of view the VRFB systems present higher short-term risks than the SSL systems. However, the above conclusions may be due to the fact that the VRFB technology is not as mature as SSL technology and therefore there is not as much operating experience and accident information available for the VRFB. Overall, from and SHE RA points of view, there is no specific preference for a type of technology.
- From a SHE risk assessment point of view, where there is a choice of location that is further from public roads, water courses or isolated farmhouses/occupied developments, this would be preferred. VRFB

hazards are mostly related to possible loss of containment of electrolyte and SSL batteries to fires producing toxic smoke and fire fighting which may result in contaminated of firewater runoff. One would not want these liquids to enter water courses nor the smoke to pass close to houses / public traffic. The current chosen location meets these separation requirements, and the relevant specialists such as aquatic and geohydrology have provided inputs on setback distances.

- Changes to the detailed layouts post Environmental Authorisation (should such be granted) are deemed acceptable if the changes remain within the approved buildable areas / development footprints, and area assessed during this Scoping and EIA Process (with the avoidance of no-go sensitive areas) and any solid state (e.g. lithium) BESS is located over 500m from farm buildings.

3. RECOMMENDATIONS

The following recommendations have been made:

- There are numerous different battery technologies but using one consistent battery technology system for the BESS installations associated with all the Kudu developments in the De Aar area would allow for ease of training, maintenance, emergency response and could significantly reduce risks.
- Where reasonably practicable, state-of-the-art battery technology should be used with all the necessary protective features e.g., draining of cells during shutdown and standby-mode, full BMS with deviation monitoring and trips, leak detection systems.
- There are no fatal flaws associated with the proposed Kudu 7 SEF battery installation for either technology type.
- The tables in Section 4 of this report contains technical and systems suggestions for managing and reducing risks. Ensure the items listed in these tables under preventative and mitigative measures are included in the design.
- The overall design should be subject to a full Hazop prior to finalization of the design.
- For the VRFB systems an end of life (and for possible periodic purging requirements) solution for the large quantities of hazardous electrolyte should be investigated, e.g., can it be returned to the supplier for re-conditioning.
- Prior to bringing any solid-state battery containers into the country, the contractor should ensure that:
 - An Emergency Response Plan is in place that would be applicable for the full route from the ship to the site. This plan would include details of the most appropriate emergency response to fires both while the units are in transit and once they are installed and operating.
 - An End-of-Life plan is in place for the handling, repurposing or disposal of dysfunctional, severely damaged batteries, modules and containers.
- The site layout and spacing between lithium solid-state containers should be such that it mitigates the risk of a fire or explosion event spreading from one container to another.
- Under certain weather conditions, the noxious smoke from a fire in a lithium battery container could travel some distance from the unit. The smoke will most likely be acrid and could cause irritation, coughing, distress etc. Close to the source of the smoke, the concentration of toxic gases may be high

enough to cause irreversible harmful effects. Location of the facilities needs to ensure a suitable separation distance from public facilities/residences etc. The proposed BESS location is well over 500m from isolated farmhouses/development and is therefore suitable in this context.

- In order to limit the possibility of domino failures the BESS should be separated from the substation by at least 20m.
- Where there is a choice of alternative locations for the BESS, those that are further from water courses would be preferred. VRFB hazards are mostly related to possible loss of containment of electrolyte and solid-state systems may experience fires that may result in loss of containment of liquids or the use of large amounts of fire water which could be contaminated. One would not want these run-offs to enter water courses directly. The buffer distance between water bodies and the facilities containing chemicals should be set in consultation with a water specialist and is therefore not specified in this SHE RA. It is noted that there are no tributaries of the main water courses in the area within 500m of the proposed BESS location, and therefore this is not a risk of concern.
- Finally, it is suggested once the BESS technology has been chosen and more details of the final design are available, the necessary updated Risk Assessments should be in place (prior to commencement, after environmental authorisation and other necessary approvals are granted (should such be granted)).

TABLE OF CONTENTS

15.1	INTRODUCTION	10
15.1.1	SCOPE OF ASSESSMENT	10
15.1.2	EIA REGULATION SCOPE OF APPLICATION	10
15.1.3	RISK ASSESSMENT METHODOLOGY	11
15.2.	DESCRIPTIONS	18
15.2.1	ORGANISATION, SITE LOCATION AND SURROUNDING AREAS	18
15.2.1.1	ORGANIZATION	18
15.2.1.2	LOCATION AND PHYSICAL ADDRESS	18
15.2.1.3	DESCRIPTION OF SITE AND SURROUNDINGS	18
15.2.2	TOPOGRAPHY, LAND-USE AND METEOROLOGY	23
15.2.2.1	TOPOGRAPHY	23
15.2.2.2	LAND-USE	23
15.2.2.3	METEOROLOGY	23
15.2.3	PLANT AND PROCESSES	24
15.2.3.1	PROPOSED DESIGN SOLID STATE BATTERIES – TYPICALLY LITHIUM	24
15.2.3.2	PROPOSED DESIGN - REDOX FLOW BATTERIES – TYPICALLY VANADIUM	26
15.2.3.3	STAFF AND SHIFT ARRANGEMENT	28
15.2.3.4	OPERATIONS AT THE BESS FACILITY AND PHASES OF THE BESS PROJECT	29
15.3.	HAZARD IDENTIFICATION	32
15.3.1	SOLID STATE LITHIUM BATTERY CHEMICAL HAZARDS	32
15.3.1.1	BATTERIES IN GENERAL	32
15.3.1.2	LITHIUM BATTERY CHEMISTRY	32
15.3.1.3	HAZARD - THERMAL DECOMPOSITION	32
15.3.1.4	HAZARD - PROPAGATION	33
15.3.1.5	HAZARD - ELECTROLYTE LEAKS	34
15.3.2	VANADIUM REDOX FLOW BATTERY HAZARDS	34
15.3.2.1	BATTERIES IN GENERAL	34
15.3.2.2	VANADIUM BATTERY CHEMISTRY	35
15.3.2.3	HAZARD – TOXICITY AND CORROSIVITY	36
15.3.2.4	HAZARD – ELECTRICAL SHOCK/ARC	37
15.3.2.5	HAZARD – FIRE / DEFLAGRATION	37
15.3.2.6	HAZARD - HYDROGEN GENERATION	37
15.3.2.7	HAZARD – WASTE ELECTROLYTE	38
15.3.2.8	HAZARD - ELECTROLYTE LEAKS	38
15.3.3	OTHER CHEMICALS OR HAZARDS	38
15.3.3.1	COOLING SYSTEMS	39
15.3.3.2	FIRE SUPPRESSION SYSTEMS	39
15.3.3.3	GENERAL ELECTRICAL AND ELECTRONIC EQUIPMENT	39
15.3.4	PAST ACCIDENTS AND INCIDENTS RELEVANT TO BESS	39
15.4.	RISK ASSESSMENT	45
15.4.1	SOLID STATE LITHIUM-ION BATTERY ENERGY STORAGE SYSTEMS	46
15.4.2	VANADIUM REDOX FLOW BATTERY ENERGY STORAGE SYSTEMS	78
15.5.	CONCLUSIONS AND RECOMMENDATIONS	104
15.5.1	CONCLUSIONS	104
15.5.2	RECOMMENDATIONS	106
15.6	REFERENCES	108

GLOSSARY OF SOME TERMS POSSIBLY USED IN THIS REPORT

List of units, acronyms and abbreviations used in this report	Definition
BEI	Biological Exposure Index (Refers to values in blood or urine etc as per to OHS Act)
BESS	Battery Energy Storage System
BMS	Battery Management System
dB	Decibels
DEA	Department of Environmental Affairs
DFFE	Department of Forestry, Fisheries and the Environment
EIA	Environmental Impact Assessment
EMPr	Environmental Management Programme
ERPG	Emergency Response Planning Guideline (a series of values in ppm or mg/m ³ that indicates various levels health effects if exposed to this concentration for more than 60 minutes)
E-stop	Emergency stop button
HAZOP	Hazard and Operability Study
HBA	Hazardous Biological Agents (Refers to pathogens, parasites, cell cultures etc - Refer to the Occupational Health and Safety Act, 1993 (Act No. 83 of 1993) (OHS Act)
HCS	Hazardous Chemical Substances (Refers to a list of hazardous chemicals - Refer to the OHS Act)
HV / MV	High Voltage / Medium Voltage
IDLH	Immediately Dangerous to Life and Health (a value in ppm or mg/m ³ that indicates serious health effects if exposed to this concentration for more than 30 minutes)
kW	Kilowatts
kPa	Kilopascal
m	Metres
m ²	Metres squared
m ³	Metres cubed
NEMA	National Environmental Management Act, 1998 (Act No. 107 of 1998), as amended
NFPA	National Fire Protection Agency
NRT Act	National Road Traffic Act, 1996 (Act No. 93 of 1996) (Chapter 8 deals with transportation of dangerous goods) Note various South African National Standards (SANS) are incorporated into the regulations.
OEL	Occupational Exposure Limit (usually in ppm or mg/m ³ in the air for each HCS as defined in the Hazardous Chemical Substances Regulations of the OHS Act)
OHS Act	Occupational Health and Safety Act, 1993 (Act No. 83 of 1993)
PV	Photovoltaic
RA	Risk Assessment
RQ	Reportable Quantity in terms of NEMA to DFFE
QC / QA	Quality Control or Quality Assurance
SANS	South African National Standards
SDS	Safety Data Sheet
SHE	Safety, Health and Environment
SSLB	Solid State Lithium Batteries
TWA (8 hrs)	Time weighted average of 8 hrs
VRFB	Vanadium redox flow battery
WEF	Wind Energy Facility
WBGT Index	An index in degrees Celsius composed of fractions of the Wet Bulb, Globe and Dry Bulb Temperatures (Refer to Environmental Regulations under the OHS Act)

15.1 INTRODUCTION

15.1.1 SCOPE OF ASSESSMENT

The applicant, Kudu Solar Facility 7 (Pty) Ltd, is considering a Battery Energy Storage System (BESS) to complement a solar power (Kudu 7 Photo-voltaic (PV)) generation facility near the town of De Aar in the Northern Cape.

The BESS system will have a power generation capacity of up to 500 MW and will be able to deliver up to 500 MWh. Two alternative technologies are being considered for the BESS, i.e. either Solid State (typically Lithium chemistry) (SSL) or Redox Flow (typically vanadium chemistry) (VRFB). The technology is advancing rapidly and the exact technology and chemistry will be chosen during the Engineering, Procurement and Construction (EPC) phase. For SSL batteries this would mean multiple containerised units. For VRFB, the systems can be containerized but could, in order to achieve economies of scale, be one large utility scale plant within a conventional industrial type structural steel / brick warehousing structure. In either configuration there could be large volumes of electrolyte on site either in smaller tanks inside containers or larger tanks in a building. The VRFB facilities, either containerized or as utility buildings, will be bunded to contain 110% of the largest vessel.

Supplementary infrastructure and equipment may include substations, power cables, transformers, power converters, substation buildings & offices, HV/MV switch gear, inverters and other control equipment that may be positioned within the battery containers / separate dedicated containers / the battery building / within the on-site substation complex (within which the BESS will be positioned).

The proposed BESS is subject to an Environmental Impact Assessment (S&EIA) process. In 2019, the Department of Forestry, Fisheries and the Environment (DFFE) recommended that EIA applications for BESSs, either on their own or as part of a power generation (e.g., PV or wind) application, should include a high-level Risk Assessment of the BESS considering all applicable risks (e.g., fire, explosion, contamination, end-of life disposal etc.).

This report summaries the high-level Safety Health and Environmental (SHE) Risk Assessment conducted by ISHECON for the proposed SSL or VRFB BESS at the proposed facility. Separate reports have been compiled for each of the 12 proposed Kudu Solar Facilities. This report only addresses Kudu Solar Facility 7 (hereafter referred to as the “Kudu Solar Facility” or “proposed project”).

Although this assessment is based on the best available information and expertise, ISHECON cc cannot be held liable for any incident that may occur on this installation and associated equipment which directly or indirectly relate to the work in this report.

15.1.2 EIA REGULATION SCOPE OF APPLICATION

This Risk Assessment is conducted as a technical input into the EIA process for the proposed project to comply with the requirement for a high-level SHE Assessment, and it does not necessarily comply with the requirements of a specialist study as defined in Appendix 6 of the EIA Regulations of 2014, as amended, under the National Environmental Management Act, 1998 (Act No. 107 of 1998), as amended (NEMA). This was communicated since the Scoping Phase of the proposed project and in the Plan of Study for EIA.

15.1.3 RISK ASSESSMENT METHODOLOGY

This Risk Assessment will consider the technology in detail. However, considering the general risks posed by the technology, each of the possible locations will be assessed with respect to advising on preferred locations from a SHE perspective.

Risk is made up of two components:

- The probability of a certain hazardous event or incident occurring.
- The severity of the consequences of that hazardous event / incident.

Therefore, this assessment of risk comprises:

- Identification of the likely hazards and hazardous events related to the operation of the installation.
- Estimation of the likelihood/probability of these hazardous events occurring.
- Estimation of the consequences of these hazardous events.
- Estimation of the risk and comparison against certain acceptability criteria.

For the purpose of this high-level SHE Risk Assessment a desktop study of the available information, preliminary BESS locations, reports of related incidents and various literature sources was undertaken. Based on this information the facility and the project were divided into construction, operation and decommissioning (end of life) phases.

This study makes use of a qualitative risk ranking system framework¹. The method considers the nature of what causes the effect, what will be affected and how it will be affected, as described below.

NATURE OF IMPACT	DEFINITION
Beneficial / Positive	An impact that is considered to represent an improvement on the baseline or introduces a positive change.
Adverse / Negative	An impact that is considered to represent an adverse change from the baseline, or introduces a new undesirable factor.
Direct	Impacts that arise directly from activities that form an integral part of the Project (e.g., new infrastructure).
Indirect	Impacts that arise indirectly from activities not explicitly forming part of the Project (e.g., noise changes due to changes in road or rail traffic resulting from the operation of Project).
Secondary	Secondary or induced impacts caused by a change in the Project environment (e.g., employment opportunities created by the supply chain requirements).
Cumulative	Impacts are those impacts arising from the combination of multiple impacts from existing projects, the Project and/or future projects.

A Health and Safety Risk Assessment is focussed on hazards arising from the construction, operation and decommissioning of a facility and their impact on humans, either employees or members of the public outside the site. By definition the nature of the chemical and machine hazards is negative, i.e., adverse impact on health and safety. Some of the impacts are immediate and direct such as effects of fires and explosions or exposure to high concentrations of chemicals (in health and safety we refer to these as acute impacts). Other impacts are longer term such as repeated exposure to low concentrations of harmful chemicals, noise etc. (in health and safety we refer to these as chronic impacts).

¹ Adapted from a method developed by WSP to meet the combined requirements of international best practice and NEMA, Environmental Assessment Regulations, 2014, as amended (GN No.326) (the “EIA Regulations”).

Using the checklist detailed in Table 15.1.3.1 the hazards in each section/phase were identified. Each identified hazard was then described by the assessor in terms of causes, consequences, preventive and mitigative measures in place.

Each hazard was qualitatively dimensioned and assessed using the method as per Table 15.1.3.2. There are five dimensioning criteria in this method:

- a) The magnitude of impact on the processes of interest (i.e., human health and safety) e.g., no impact, moderate impact and will alter the operation of the process (e.g., injuries), very high impact and will destroy the process (e.g., fatalities).
- b) The physical extent, e.g., will it be limited to the site or not.
- c) The duration, i.e., how long will the person bear the brunt of the impact.
- d) Reversibility: an impact may either be reversible or irreversible, e.g., fatalities are permanent, while it may be possible to recover from injuries.
- e) The probability of occurrence of the impact.

After dimensioning these aspects, a combined overall risk / significance was calculated for each hazard, see Table 15.1.3.3.

The impact significance without design controls, preventative and mitigation measures will be assessed. Impacts without mitigation measures in place are not representative of the proposed development's actual extent of impact and are included to facilitate understanding of how and why mitigation measures were identified.

The residual impact is what remains following the application of mitigation and management measures and is thus the final level of impact associated with the development.

Residual impacts also serve as the focus of management and monitoring activities during Project implementation to verify that actual impacts are the same as those predicted in this Report.

There are other specialist assessments being carried out as part of the S&EIA process, for example assessments in the field of impacts on terrestrial biodiversity, including fauna and flora, aquatic biodiversity, avifauna etc. The focus of this study is on human health and safety with possible impacts from chemicals, fires, explosions etc. and on broad issues of chemical pollution, emissions and waste of resources.

TABLE 15.1.3.1 SAFETY, HEALTH AND ENVIRONMENTAL RISK ASSESSMENT CHECKLIST

NO	RISKS	DESCRIPTION OF TYPICAL HAZARDS	TYPICAL STANDARD (OHS Act) OR KEY ISSUES
	HEALTH RISKS		
H1	Chronic Chemical or Biological Toxic Exposure	Continuous releases of toxic materials (Chemical or biological) Long term exposure to low concentrations Unsanitary or unhygienic conditions Diseases Harmful animals/insects	Do not exceed Occupational Exposure Limits (OEL's) and Biological Exposure Indices (BEI's – OHS Act Hazardous Chemical Substances (HCS) and Hazardous Biological Agents (HBA) Regulations)) for continuous work time exposure to hazardous chemical substances and materials. Awareness of HBA.
H2	Noise	Continuous and peak exposure to high levels of noise	Continuous noise not to exceed 85dB at workstation (OHS Act Noise-Induced Hearing Loss Regulations) and 61dB at boundary of the site.
H3	Environmental	High temperatures in work areas Low temperatures in work areas High humidity in work areas	Wet Bulb Globe Temperature (WBGT) index above 30 in summer and/or very cold less than 6 deg C in winter (OHS Act Environmental Regulations for Workplaces)
H4	Psychological	Inherently dangerous tasks Monotonous tasks High production pressure	
H5	Ergonomics	Bad ergonomic design, chronic or acute impact Vibration, repetitive impact	Maximum weight to lift 20 – 25kg
	SAFETY RISKS		
S1	Fire	Internal and external fire Small fire Large fires	Upper and lower flammability limits for materials. 12.5 kW/m ² for 1-minute leads to 1% fatalities. 37.5 kW/m ² leads to >90% fatalities and probable structural failure.
S2	Explosion	Internal explosions inside equipment Confined explosion inside structures Unconfined explosions outside	7 kPa overpressure leads to minor structural damage. 70 kPa leads to 90 % fatalities and probable structural failure.
S3	Acute Chemical or Biological Toxic Exposure	Large releases of toxic gases Exposure to high concentrations of harmful materials Asphyxiation inside a vessel Exposure to corrosive materials, burns	Immediately Dangerous to Life and Health values (IDLH) and Emergency Response Planning Guidelines (ERPG's) for all materials. Minimum oxygen levels.

NO	RISKS	DESCRIPTION OF TYPICAL HAZARDS	TYPICAL STANDARD (OHS Act) OR KEY ISSUES
		Ingestion of poisonous materials	Low or high pH.
S4	Acute physical Impact or violent release of energy	Slips and trips Working at heights Moving equipment, objects or personnel	
S5	Generation impact	Electrocution Radiation sources Lasers Static Lightning	
	ENVIRONMENTAL RISKS		
E1	Emissions	Continuous emissions	Exceeding permitted emission levels
E2	Pollution	Unplanned pollution incidents causing immediate damage	Not transporting as per legislation (SANS10228/0229 and Haz. Subs. Act – Road Tanker Regs.) Hazmat requirements Reportable spill quantities NEMA Section 30
E3	Waste of resources	Water Power Other non-renewable resources (minerals) Biodiversity	Exceeding water consumption permits Peak demand requirements
	GENERAL RISKS		
G1	Aesthetics	Tall unsightly structures Glaring glass Odours	
G2	Financial	Risks of litigation Business collapse – recovery after emergency Sustainability	Business continuity Std SANS22301
G3	Security	Theft Hi-jacking Looting	
G4	Emergencies	Emergencies originating off-site (neighbours) Natural disasters	MHI Emergency Response Planning SANS1514
G5	Legal compliance		

TABLE 15.1.3.2 – SHE QUALITATIVE RISK ASSESSMENT MATRIX

a) The magnitude of impact on human health and safety and environmental pollution, quantified on a scale from 0-5, where a score is assigned.

SCORE	DESCRIPTION
0	small and will have no effect on the environment.
1	minor and will not result in an impact on processes.
2	low and will cause a slight impact on processes.
3	moderate and will result in processes continuing but in a modified way.
4	high (processes are altered to the extent that they temporarily cease).
5	very high and results in complete destruction of patterns and permanent cessation of processes.

b) The physical extent.

SCORE	DESCRIPTION
1	the impact will be limited to the site;
2	the impact will be limited to the local area;
3	the impact will be limited to the region;
4	the impact will be national; or
5	the impact will be international.

c) The duration, wherein it is indicated whether the lifetime of the impact will be:

SCORE	DESCRIPTION
1	of a very short duration (0 to 1 years)
2	of a short duration (2 to 5 years)
3	medium term (5–15 years)
4	long term (> 15 years)
5	permanent

d) Reversibility: An impact is either reversible or irreversible. How long before impacts on receptors cease to be evident.

SCORE	DESCRIPTION
1	The impact is immediately reversible.
3	The impact is reversible within 2 years after the cause or stress is removed; or
5	The activity will lead to an impact that is in all practical terms permanent.

e) The probability of occurrence, which describes the likelihood of the impact actually occurring.

SCORE	DESCRIPTION
1	very improbable (probably will not happen).
2	improbable (some possibility, but low likelihood).
3	probable (distinct possibility).
4	highly probable (most likely).
5	definite (impact will occur regardless of any prevention measures).

TABLE 15.1.3.3 – CALCULATION AND INTERPRETATION OF RISK / SIGNIFICANCE

The final assessment of the risk, i.e., the significance, of a particular impact is determined through combination of the characteristics described above (refer formula below)

$$\begin{aligned} \text{Risk} &= \text{Consequence} \times \text{Likelihood} \\ \text{Significance} &= (\text{Extent} + \text{Duration} + \text{Reversibility} + \text{Magnitude}) \times \text{Probability} \end{aligned}$$

The risk (significance) can then be assessed as very low, low, medium, high or very high as follows:

OVERALL SCORE	SIGNIFICANCE RATING (NEGATIVE)	SIGNIFICANCE RATING (POSITIVE)	DESCRIPTION
4-15	Very Low	Very Low	Where the impact is negligible
16-30	Low	Low	Where this impact would not have a direct influence on the decision to develop in the area
31-60	Moderate	Moderate	Where the impact could influence the decision to develop in the area unless it is effectively mitigated
61-80	High	High	Where the impact must have an influence on the decision process to develop in the area
81-100	Very High	Very High	Where the impact would indicate a potential fatal flaw

15.2. DESCRIPTIONS

15.2.1 ORGANISATION, SITE LOCATION AND SURROUNDING AREAS

15.2.1.1 ORGANIZATION

ABO Wind AG is an international company originating in Germany in 1996. The South African subsidiary of ABO Wind, ABO Wind renewable energies (Pty) Ltd, was founded in 2017. There is a local Cape Town Office with local employees working together with the international team. The company is currently working on a pipeline of around 5 GW of wind and solar projects as well as storage projects with batteries or hydrogen. The primary concept of the projects is to ensure social and environmental reliability / sustainability. ABO Wind acts as the project developer and project interface, coordinating the research and studies, the site identification, the project structure, BAs, EIAs, selecting the strategic partners and arranging financing.

15.2.1.2 LOCATION AND PHYSICAL ADDRESS

Kudu 7 Solar PV BESS

Affected properties for the BESS only: Remaining Extent of Portion 2 (Middel Plaats) (a Portion of Portion 1) of the Farm Grasspan No.40
Renosterberg Local Municipality in the Pixley ka Seme District Municipality in the Northern Cape
GPS co-ordinates: 30°12'31.12" S 24°20'29.13" E

15.2.1.3 DESCRIPTION OF SITE AND SURROUNDINGS

The maps below show that the BESS facilities are planned in an isolated location. Activities in the area consist of the low intensity livestock farming.

Figure 15.2.1.1 is a map of South Africa showing the location of the proposed Kudu Solar PV facility.

Figure 15.2.1.2 is the development area showing the location of the BESS facilities.

Figure 15.2.1.3 shows 500m circles (dark blue) around the proposed BESS Facilities as well as local farmsteads/developments with (red 500m circles), nearby water courses/bodies (light blue) and aquatic sensitivity and flood plain areas (green and yellow marked area) in the immediate vicinity of the BESS.

Figure 15.2.1.4 shows the details of the development and the location of the BESS within the substation area

Figure 15.2.1.1 - Map showing the location of the proposed Kudu Solar PV Facility within the Northern Cape, South Africa.



Figure 15.2.1.2 - The general area of interest for the BESS



Figure 15.2.1.3 – 500m circles around the BESS Facilities (Dark Blue), Location of Developments / Farmhouses (Red), Nearby Water Courses/Bodies (Light blue) and aquatic sensitivity and floodplain areas (green and yellow) in the immediate vicinity of the BESS

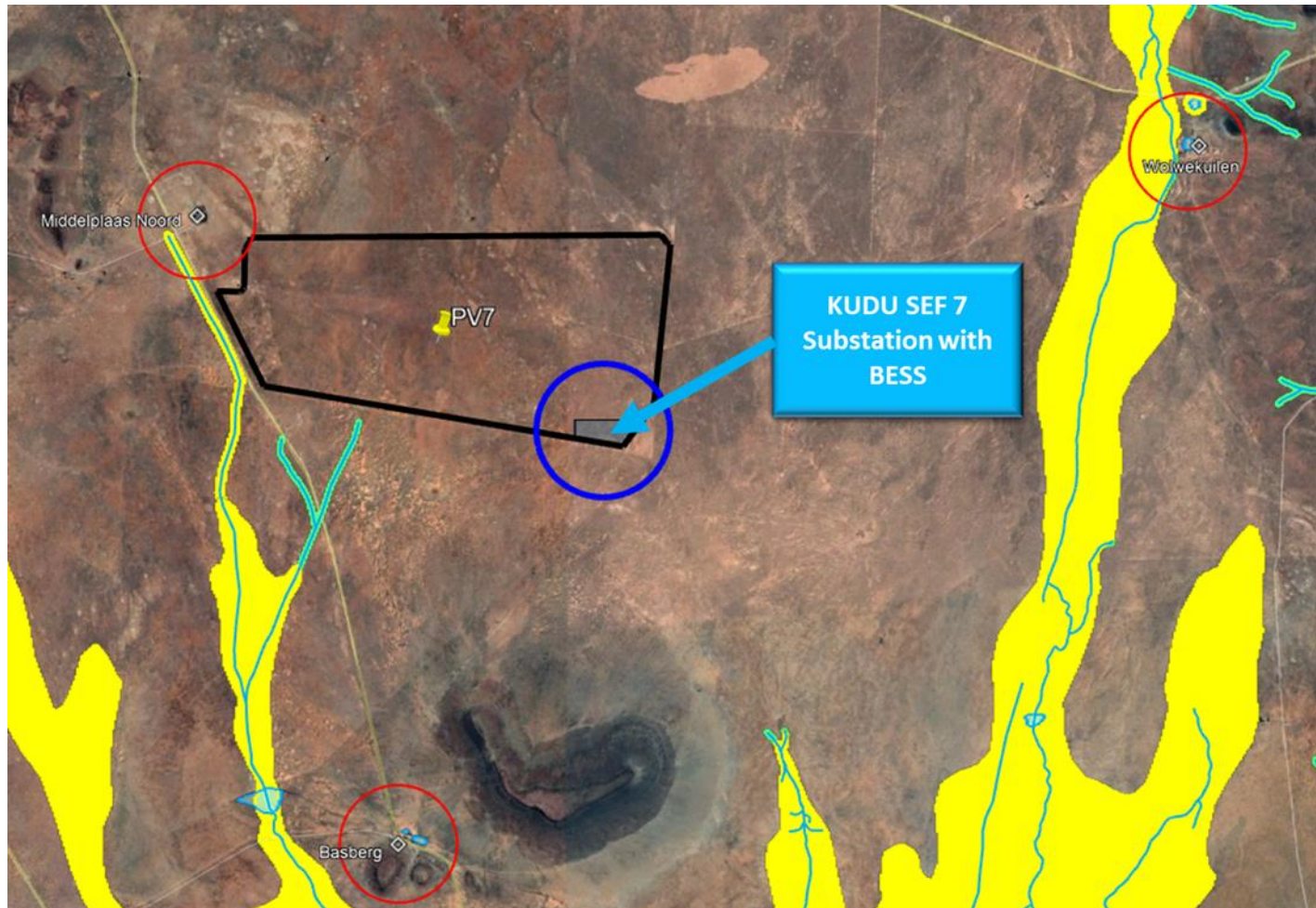
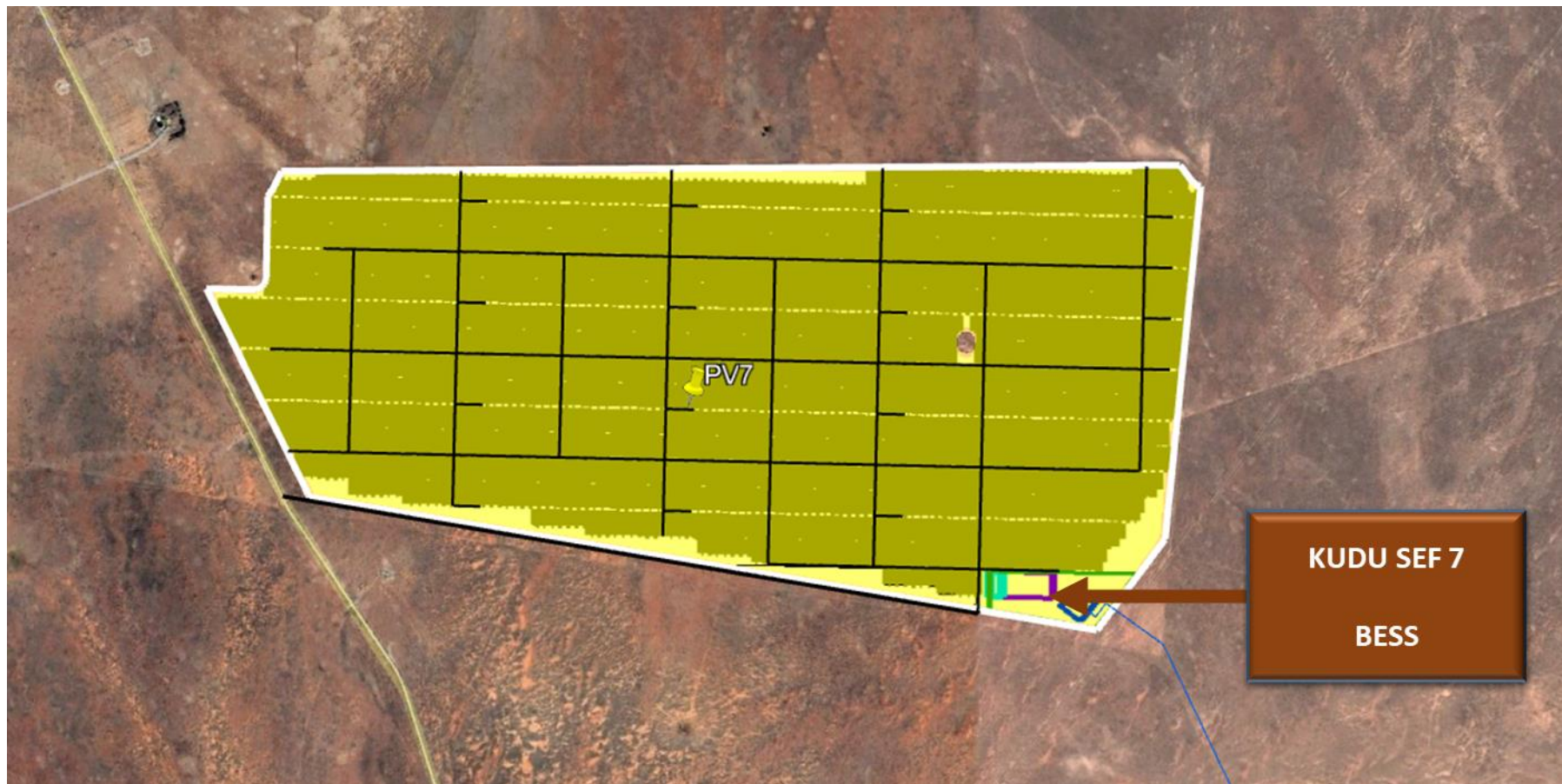

Figure 15.2.1.2 – Detailed layout of the site showing the location of the BESS within the Substation complex



15.2.2 TOPOGRAPHY, LAND-USE AND METEOROLOGY

15.2.2.1 TOPOGRAPHY

Refer to the relevant EIA specialist studies for details of flora and fauna as well as water resources in the area. Vegetation in the area is mostly dry scrub, grass and bushes closer to water courses.

The area is very flat ground with a few hills to the north.

There are dry (seasonal) rivers in the area around the BESS site. Due to the semi-arid nature of the area, these water sources, although seasonal, are critical.

15.2.2.2 LAND-USE

Refer to the relevant EIA specialist studies for details of the agricultural and commercial activities and cultural aspects in the area. The BESS facilities will not use large amounts of land typically < 5 ha.

The area is used very sparsely for agricultural activity, mostly livestock. There are few isolated farmstead developments in the general area but none of the dwellings in the area is within 500m of the proposed BESS location.

Across South Africa seismic activity is conceivable with Gauteng (man-made activity) and the Western Cape (natural activity) being relatively higher risk areas. However, compared with aspects such as corrosion, human error etc. seismic activity is not usually a highly likely risk factor, refer to SANS 10160:2011, part 4. [Ref 6]. The proposed area is a low seismic activity area and civil / structural design of the BESS facilities would not normally need to take major additional seismic protection into account. Refer to the Geotechnical Assessment undertaken as part of the EIA Process.

15.2.2.3 METEOROLOGY

Weather data for De Aar indicates that the wind blows predominantly from the north, north west and west. There is very little wind from the east and south. The winds vary from virtually nothing to strong winds in September/October. Given the proposed locations of the BESS facilities this means that the wind blows across the BESS facilities away from any occupied farmsteads.

The area has very little rain but long days with plenty of sunshine and summer daytime temperatures in the mid-thirties. Day night variations are typically 15 degrees Celsius or more.

Across South Africa, lightning strikes are conceivable as a source of ignition of major hazards, refer to SANS10313:2012 lightning strike density table [Ref 7]. The lightning ground flash density in De Aar is 3.3 flashes/km²/year which is at the middle to lower end of the spectrum in South Africa, e.g. Piet Retief is 15.1 flashes/km²/year and Boksburg as 12.1 flashes/km²/year while areas such as Cape Town are 0.1 flashes/km²/year. Nevertheless, ignition from on-plant sources is much more likely than lightning, but lightning cannot be ignored as a source of risk particularly for tall structures in wide open flat areas.

15.2.3 PLANT AND PROCESSES

15.2.3.1 PROPOSED DESIGN SOLID STATE BATTERIES – TYPICALLY LITHIUM

The one type of battery technology being considered for each BESS is a Solid-State Battery which consists of multiple battery cells that are assembled together to form modules. Each cell contains a positive electrode, a negative electrode and an electrolyte. The BESS will comprise of multiple battery units or modules housed in shipping containers and/or an applicable housing structure which is delivered pre-assembled to the project site. Containers are usually raised slightly off the ground and laid out in rows. They can be stacked if required although this may increase the risk of events in one container spreading to another container. Supplementary infrastructure and equipment may include substations, power cables, transformers, power converters, substation buildings and offices, HV/MV switch gear, inverters and temperature control equipment that may be positioned between, adjacent to or in the vicinity of the battery containers. The solid-state batteries that are being considered are Lithium-ion systems. The pictures in Figure 15.2.3.1.1 are typical BESS installations servicing solar power farms. Figures 15.2.3.1.2 & 15.2.3.1.3 show typical battery modules in the BESS facility.

FIGURE 15.2.3.1.1 – Images of Typical BESS Systems Servicing Solar Power Farms



Source – computer generated artist impressions

FIGURE 15.2.3.1.2 – Typical Battery Modules in a BESS with the Separated Sections

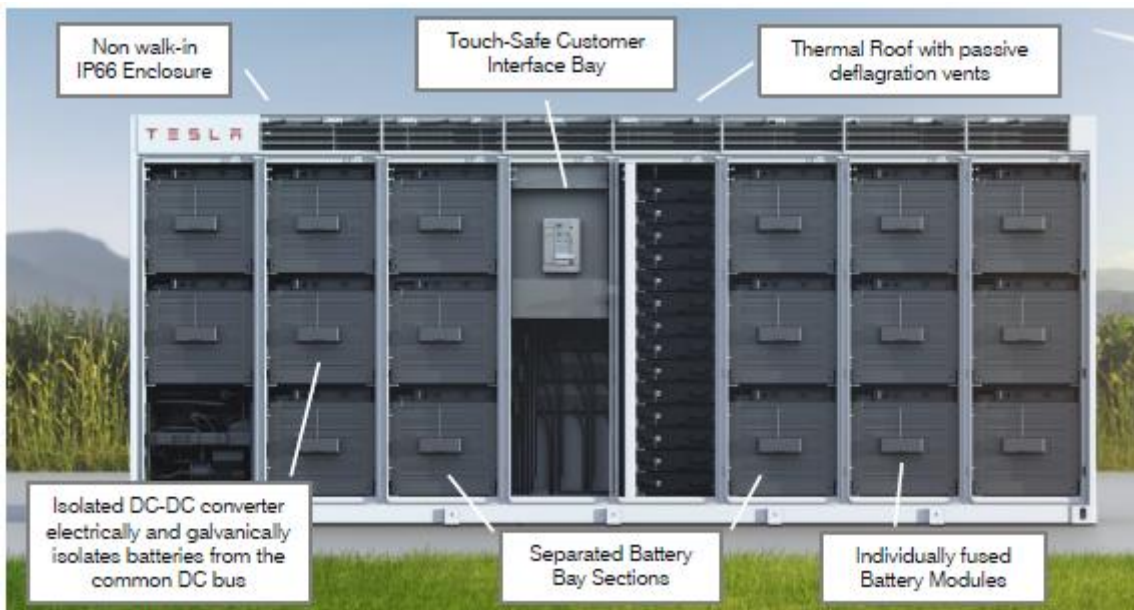

Source – Tesla MegaPack – Safety Overview

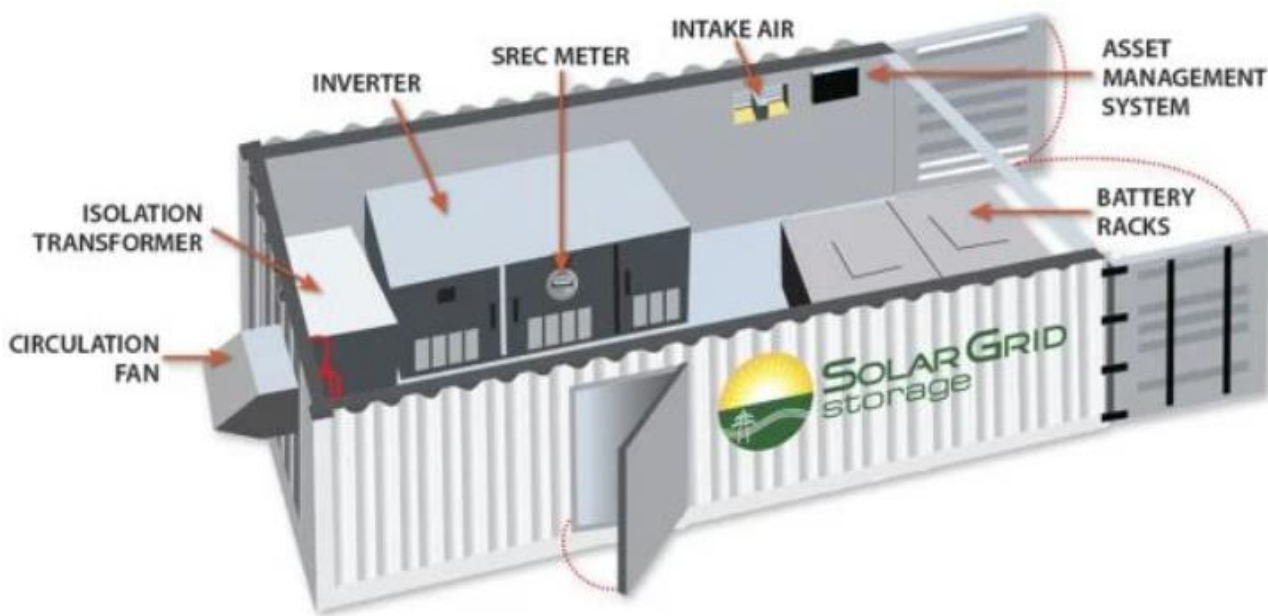

Source – Tesla MegaPack – Safety Overview

FIGURE 15.2.3.1.3 – Typical Battery Modules in a BESS with the Power Conversion Systems in with the Batteries

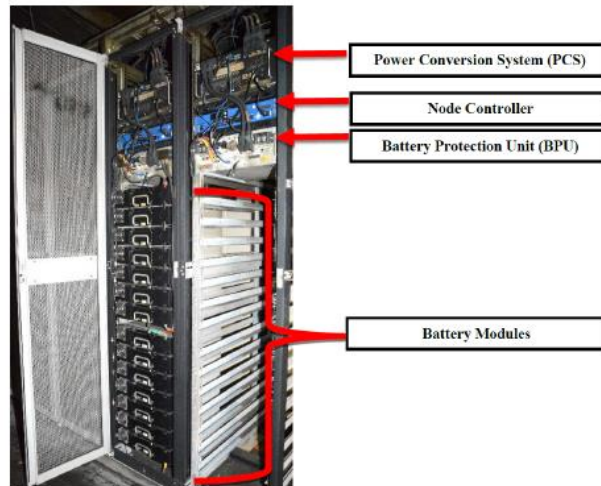

Source – DNV-GL McMicken Event Analysis

15.2.3.2 PROPOSED DESIGN - REDOX FLOW BATTERIES – TYPICALLY VANADIUM

One of the types of battery technology being considered for the BESS would be VRFB. These energy storage systems can be supplied either as containerized units or as a fixed installation within a building etc.

In order to present contrasting hazards with the containerized lithium batteries in the section above, this report will discuss utility scale redox flow system, i.e. not containerized redox flow batteries. Due to the proposed size of the facility (up to 500MW), and in order to highlight the possible more extreme differences between technology types, the facility can be envisioned as having redox units housed within a large battery building. If containerized systems are used, the essential hazards remain the same, but may just be slightly smaller in magnitude. For this project (up to 500 MW) there are expected to be up to 720 containers, each with six 25m³ tanks of electrolyte within the containers, hence approximately 108 000 m³ of electrolyte in the entire project. Each container acts as bund (secondary containment) able to hold at least the volume of one tank. In addition a bund mound/trench (tertiary containment primarily for any runoff) will be constructed around the entire facility. The pictures in Figure 15.2.3.2.1 and Figure 15.2.3.2.2 are typical Redox Flow BESS installations.

FIGURE 15.2.3.2.1 – Images of Some Redox Flow BESS Systems – containerized systems or buildings with tanks of electrolyte and battery systems



1 MW 4 MWh containerized vanadium flow battery owned by Avista Utilities and manufactured by UniEnergy Technologies



Source – Bulk Redox flow batteries for renewable energy storage, 21 Jan 2020, J Noak, N Roznyatovskaya, C Menictas, M Skyllas-Kazacos



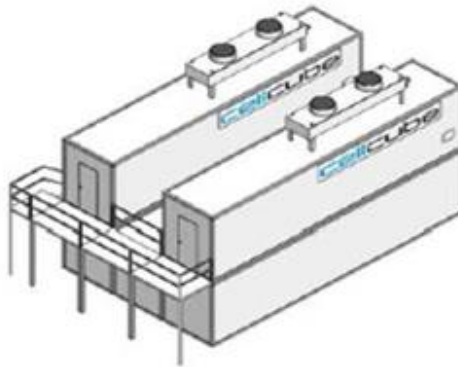

Source – Bushveld Minerals and Energy – Energy Storage and Vanadium Redox Flow batteries 101 – 13 November 2018.
And general Product Info 2023

Within each unit, battery cells are assembled together to form stacks, the image below showing a view of typical stack.

FIGURE 15.2.3.2.2 – Typical Battery Cell and Stack Set-up



Stacks of a 2MW/20MWh vanadium redox flow battery at Fraunhofer ICT. Image:

15.2.3.3 STAFF AND SHIFT ARRANGEMENT

The BESS facilities will run 7 days a week for 24 hours a day. Although the system will be largely automated with a battery management system and electronic operator interface etc, it will still require attention from operators and maintenance staff. The facility will need routine checking / preventative and breakdown maintenance / grass cutting / security etc. During normal operations there are assumed to be approximately 8 persons on site during the day depending on the activities taking place and possibly one or two operators/maintenance staff as well as security personnel at night.

15.2.3.4 OPERATIONS AT THE BESS FACILITY AND PHASES OF THE BESS PROJECT

The BESS facilities can be considered to have three main phases:

- Construction including transport to site and storage prior to installation,
- Operation including commissioning, maintenance, shutdown – restart, and
- Decommissioning including repurposing and disposal.

The main processes undertaken in each of these stages can be summarized as follows together with some details:

TABLE 15.2.3.4.1 – Project Phase with Main Processes/Activities and Some Details of Likely Elements

No	PHASE	MAIN PROCESSES	DETAILS
1.1	Construction of both types of battery technology	Construction machines e.g., cranes, graders, cement trucks, diesel and oil storage	Graders to clear ground and make roads, diggers for trenches and foundations, cement mixers for civil works, cranes to place containers, diesel bowser for fuel for machines, oil for machines
1.2		Materials for the construction of the Vanadium Redox Flow Battery (VRFB) building / container plinths Equipment items for installations within the VRFB building	Building materials such as bricks, cement, re-bar, I-beams, roof sheeting etc. BESS equipment such as tanks, pumps, piping etc. Electrical equipment such as transformers, pylons, cabling.
		Equipment items for containerized installation e.g., lithium battery containers / VRFB containers	Battery containers Electrical equipment such as transformers, pylons, cabling.
1.3		Waste e.g., packaging materials, paint	Connections, transformers, switches etc will likely have protective coverings (Plastic, paper, cable ties etc) to remove during installation, paint waste (cans, brushes, solvents), and building rubble
1.4		Construction camp	Temporary offices, accommodation, ablutions
2.1	VRFB Operation	Chemical electrolyte and electrode materials in the battery cell	Tanks, pumps and pipes containing electrolyte, typically vanadium dissolved in an acidic solution.
2.2		Battery cells, stacks	The batteries will be able to generate up to 500 MW of power for four hours. The electrolyte storage will have capacity to dispatch up to 500 MWh.
2.3		Electronic equipment in building / container	Battery management system for monitoring of the batteries and control of the loading and unloading cycles
2.4		Electrical equipment inside	Power conversion system, connections, switches, cabling
2.5		Support mechanical equipment	Air conditioners, fans, coolant
2.6		Electrical equipment outside	Network interconnection equipment, switchgear, transformers
2.7		Site office and workshop	Including potable water, 220V power, kitchen, sewage, tools and parts store etc
2.8		Support services	Dirt roads, access control fences, lights inside the container and outside for general access lighting, fire suppression/fighting systems, grass cutting, communication systems
2.9		Waste	Broken parts, storm water run-off, hot air from battery and Power Conversion System (PCS) cooling systems, waste electrolyte from maintenance or other spills
2.10		Lithium Solid State Operation	Chemical electrolyte and electrode materials in the battery cell
2.11	Battery cells, modules and racks typically in shipping containers		The facilities are designed for up to 500 MW/500 MWh having typically ~ 700 containers. (for example, each Tesla Megapack has up to 3 megawatt hours (MWhs) of storage and 1.5 MW of inverter capacity, other units only have a power rating of just over 0.7 MW per container).

2.12		Electronic equipment in container	Battery management system for monitoring of the batteries and control of the loading and unloading cycles
2.13		Electrical equipment in container or separate container	Power conversion system, connections, switches, cabling
2.14		Mechanical equipment in container(s)	Air conditioners, fans, filters, coolant
2.15		Electrical equipment outside the containers	Network interconnection equipment, switchgear, transformers
2.16		Site office and workshop	Including potable water, 220V power, kitchen, sewage, tools and parts store etc
2.17		Support services	Dirt roads, access control fences, lights inside the container and outside for general access lighting, fire suppression/fighting systems, grass cutting, communication systems
2.18		Waste	Broken parts, storm water run-off, hot air from battery and PCS cooling systems
3.1	Decommissioning both types of battery technology	VRFB Liquid chemical waste	Waste electrolyte solution, transformer oils, coolants
		Solid State Lithium chemical waste	Batteries, air filters, transformer oils, coolants
3.2		Electronic waste	Circuit boards, HMI screens
3.3		Building rubble - non-hazardous waste	Steel, copper, cement, equipment and structures
3.4		VRFB Hazardous waste	Contaminated equipment such as pumps, pipes, bund linings
3.5		Lithium Containers	Shipping containers

15.3. HAZARD IDENTIFICATION

15.3.1 SOLID STATE LITHIUM BATTERY CHEMICAL HAZARDS

15.3.1.1 BATTERIES IN GENERAL

Lithium-ion based battery systems are becoming one of the dominant technologies for utility systems in Europe and America. For this reason, this assessment assumes that lithium-based batteries will be used in the BESS facilities. Should sodium-based batteries be used, the hazards are likely to be similar at a high level but different in their details, and therefore the Risk Assessment may need to be reviewed.

Primary (non-rechargeable) batteries use lithium metal anodes. Lithium is one of the lightest and most reactive metallic elements and is highly reactive towards water and oxygen. Exposure of lithium metal to water even as humidity can decompose exothermically to produce flammable hydrogen gas and heat. These lithium metal batteries are not used in BESS systems. However, if secondary batteries discussed below are charged at temperatures below 0 degrees Celsius, then lithium can plate out onto the anode surface and in this manner lithium metal could be present even in lithium-ion batteries.

Secondary, rechargeable lithium batteries, as used in bulk BESSs, use cathodes that contain lithium in the crystal structure of the cathode coating and/or lithium salts in an electrolyte that is in the battery. These are called lithium-ion batteries. Lithium-ion batteries operate at room temperature and have significant limitations outside the 0 – 50 degree range. The exact lithium-ion composition of the batteries can vary with suppliers. In addition, the technology allows for many combinations of chemistry to suit the particular application.

15.3.1.2 LITHIUM BATTERY CHEMISTRY

The lithium in the batteries is usually in the form of lithium salts dissolved in an electrolyte solution that is absorbed within the electrodes and/or lithium plated onto the surface of the electrode. These are referred to as solid state batteries because electrolyte liquid is not freely available in a form that can easily leak or be extracted. The electrolytes are typically ethylene carbonate or di-ethyl carbonate. The flash points of these carbonates can vary from 18 – 145 deg C which means they can be highly flammable (Flash Point FP < 60 deg C) or merely combustible if involved in an external fire (FP > 60 deg C). Some of the lithium compound in the electrolyte include lithium hexafluorophosphate, lithium perchlorate, lithium cobalt oxide etc.

15.3.1.3 HAZARD - THERMAL DECOMPOSITION

Upon heating of the contents of a battery due to shorting, contaminants, external heat or exposure to water and reaction heat, the lithium salts in batteries begin to break down exothermically to release either oxygen (oxidants) that enhances combustion, possibly leading to explosion, or fumes such as hydrogen fluoride or chlorine that are toxic.

These exothermic break down reactions are self-sustaining above a certain temperature (typically 70 deg C) and can lead to thermal run away. In this process the battery gets hotter and hotter, the decomposition reactions happen faster and faster, and excessive hot fumes are generated in the battery. Eventually the pressure in the battery builds up to the point where those gases need to be vented, usually via the weakest point in the system. These vented fumes can be flammable due to vaporization of the electrolyte and can ignite as a flash fire or fire ball (if large amounts) leading to the fire spreading to any surrounding combustible materials, e.g., plastic insulation on cables, the electrolyte, the electrodes and possibly even the plastic parts

of the battery casing etc. If the vented flammable vapours do not ignite immediately, they can accumulate within the surrounding structures. If this flammable mixture is ignited later, e.g., due to a spark, this can lead to a violent explosion of the module, cabinet, room, container etc.

In addition to being flammable the vented gases will contain toxic components. These could include:

- the products of combustion such as carbon dioxide/monoxide, hydrogen cyanide,
- VOCs like benzene and ethylene, and
- decomposition products such as hydrogen fluoride, hydrogen chloride, phosphorous pentafluoride, phosphoryl fluoride and oxides of aluminium, cobalt, copper etc.

The temperature in the batteries and of these vented gases can be extremely high, e.g., > 600 deg C.

In the situation where oxygen is released internally as part of the decomposition (e.g., lithium perchlorate) the oxygen is available to react with the combustible electrolyte and if all this happens extremely fast in a self-sustaining manner within the confines of the device, an explosion of the device can occur with only localized impacts.

15.3.1.4 HAZARD - PROPAGATION

A BESS is composed of individual batteries which are combined into different size packs such as modules and racks, as illustrated on the diagram below.

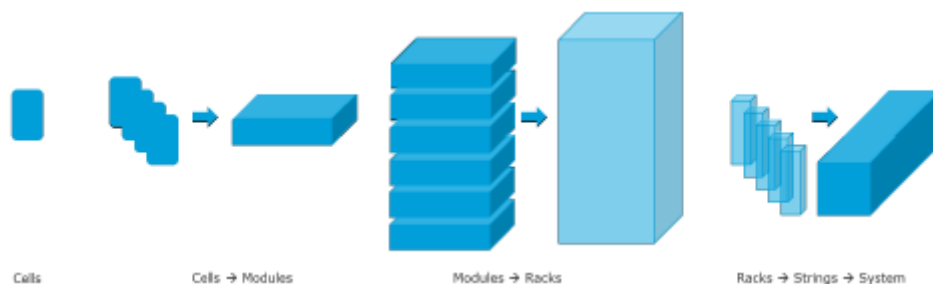

Source DNV-GL McMicken Event Analysis

The very high temperature generated by one battery cell in thermal run away could lead to overheating of adjacent cells. This cell in turn then starts thermal decomposition and so the process propagates through the entire system, as illustrated on the diagram below.

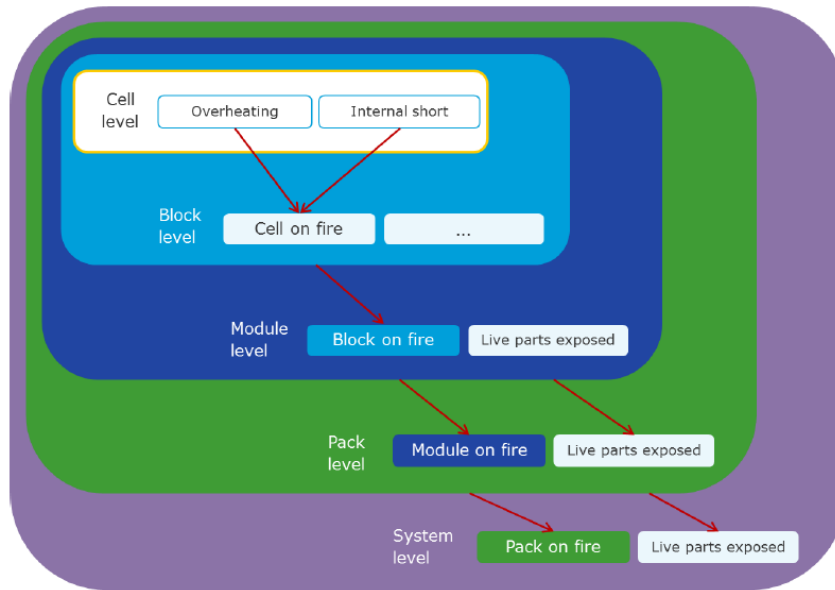

Source – STALLION Report

In order to prevent propagation, there are separation requirements between cells, modules etc. Separation could be with physical space or insulating materials etc.

15.3.1.5 HAZARD - ELECTROLYTE LEAKS

Although extremely unlikely due to the structure of the batteries, should electrolyte liquid leak out of the batteries, it can be potentially flammable as well as corrosive etc. If ignited as fire, or explosion, the smoke would contain toxic components. If unignited it can still be extremely harmful especially if its decomposition products include hydrofluoric acid.

15.3.2 VANADIUM REDOX FLOW BATTERY HAZARDS

15.3.2.1 BATTERIES IN GENERAL

All electrochemical energy storage systems convert electrical energy into chemical energy when charging, and the process is reversed when discharging. With conventional batteries, the conversion and storage take place in closed cells. With redox flow batteries, however, the conversion and storage of energy are separated. Redox flow batteries differ from conventional batteries in that the energy storage material is conveyed by an energy converter. This requires the energy storage material to be in a flowable form. In redox flow batteries, charging and discharging processes can take place in the same cell. Redox flow batteries thus have the distinguishing feature that energy and power can be scaled separately. The power determines the cell size, or the number of cells and the energy is determined by the amount of the energy storage medium. In theory, there is no limit to the amount of energy that can be produced and/or stored thereby allowing for scalability of these systems.

Figure 15.3.2.1 shows the general operating principle of redox flow batteries. The energy conversion takes place in an electrochemical cell which is divided into two half cells. The half cells are separated from each other by an ion-permeable membrane or separator, so that the liquids of the half cells mix as little as possible. The separator ensures a charge balance between positive and negative half cells, ideally without the negative

and positive active materials coming into direct contact with each other. In fact, however, separators are not perfect so some cross-over of the active materials always occurs and this leads to the self-discharge effect.

FIGURE 15.3.2.1 – Schematic Diagrams of Redox Flow BESS Systems

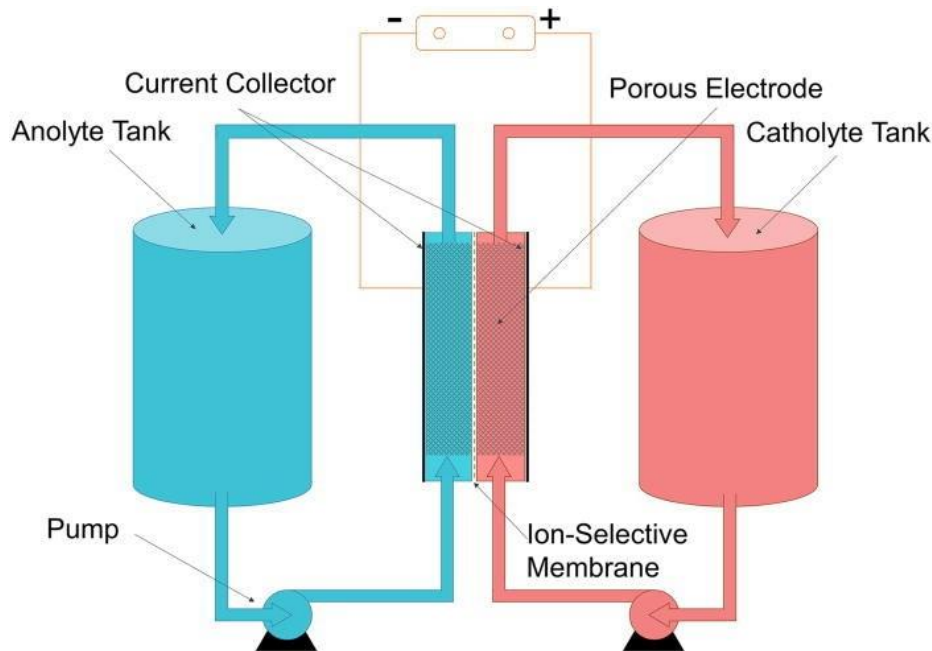

Source – WIKIPEDIA

15.3.2.2 VANADIUM BATTERY CHEMISTRY

The vanadium redox battery (VRB), also known as the vanadium flow battery (VFB) or vanadium redox flow battery (VRFB), is a type of rechargeable flow battery that employs vanadium ions in different oxidation states to store chemical potential energy. The vanadium redox battery exploits the ability of vanadium to exist in solution in four different oxidation states, and uses this property to make a battery that has just one electroactive element instead of two.

The possibility of creating a vanadium flow battery was explored by Pissoort in the 1930s, NASA researchers in the 1970s, and Pellegrini and Spaziante in the 1970s, but none of them were successful in demonstrating the technology. The first successful demonstration of the all-VRFB which employed vanadium in a solution of sulfuric acid in each half was by Maria Skyllas-Kazacos at the University of New South Wales in the 1980s. In redox flow batteries, the electrodes should not participate in the reactions for energy conversion and should not cause any further side reactions (e.g., undesirable gas formation). Most redox flow batteries are therefore based on carbon electrodes.

The redox pair VO_2^+/VO_2 are at the positive electrode and the redox pair V^{2+}/V^{3+} at the negative electrode. The use of the same ions in the positive and negative electrolytes permits relatively high concentrations of active material. It also overcomes the cross-contamination degradation issues which plague other flow type batteries. The energy storage solution consists primarily of vanadium sulphate in a diluted (2mol/L) sulphuric acid (possibly containing a low concentration of phosphoric acid) and is therefore roughly comparable to the acid of lead/acid batteries. The energy density is limited by the concentration of the pentavalent $+VO_2$.

The VRFB is without doubt the best investigated and most installed redox flow battery.

For several reasons, including their relative bulkiness, most vanadium batteries are currently used for grid energy storage, i.e., attached to power plants or electrical grids. Currently, there are over 100 VRFB installations globally with an estimated capacity of over 209,800 kWh of energy and the use of vanadium in energy storage applications has doubled to 2.1% of the global vanadium consumption in 2018.

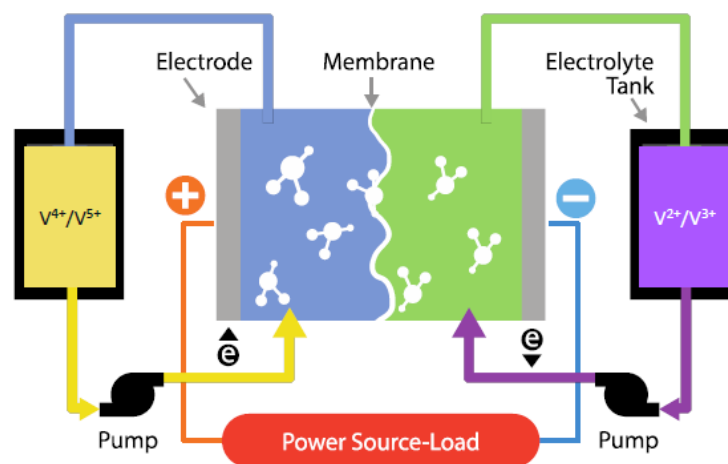

Source: IEEE Spectrum: "It's Big and Long-Lived, and It Won't Catch Fire: The Vanadium Redox-Flow Battery", 26 October 2017

15.3.2.3 HAZARD – TOXICITY AND CORROSIVITY

The electrolyte in the VRFB system is corrosive. It is composed of a sulphuric acid-based solution similar to common automotive lead acid batteries. Unlike traditional lead-acid batteries, VRBs do not include lead. Therefore, VRBs do not have the toxicity issues of lead that conventional car batteries have. The only potential source of human toxicity in a VRB is Vanadium.

Vanadium in various physio-chemical states can have a relatively high aquatic and human toxicity. Acute oral exposure to high doses can lead to haemorrhaging, while chronic exposure leads to adverse effects on the digestive system, kidneys and blood (diarrhoea, cramps etc.).

Inhalation hazards lead to irritation of the respiratory tract, bronchospasm, and pulmonary congestion. There is little evidence that vanadium compounds are reproductive toxics or teratogens. There is also no evidence that it is carcinogenic (Source USA EPA Risk Assessment Information Systems, Toxicity Profiles, Vanadium 1998).

In the electrolyte the concentration levels of Vanadium are so low that when it is mixed into liquid form in the final product and put into operation, the VRB is deemed non-toxic. In addition, VRBs have a lower concentration of sulfuric acid than traditional lead-acid batteries. Vanadium poses a hazard when it is in powder form, i.e. when making up the electrolyte solution. The facilities will purchase the liquid electrolyte solution already made up and there will be no solid vanadium powder on site.

Toxicity or corrosion risks may be present from off-gassing produced by over-heating aqueous or vaporized electrolytes. In addition, flow batteries in fire scenarios may generate toxic gas from the combustion of hydrocarbons, plastics, or acidic electrolytes. Refer to sections on fire below for mitigation measures.

15.3.2.4 HAZARD – ELECTRICAL SHOCK/ARC

Electrical shock presents a risk to workers and emergency responders, if the energy storage system cannot be “turned off”. This is referred to as “stranded energy” and presents unique hazards. Arc flash or blast is possible for systems operating above 100 V.

In the area of shock hazard, a flow battery produces voltage only when electrolytes are in a cell stack. For most designs, if the motors are turned off and fluids drained from the cell stack, then the cell stacks have no measurable voltage at the terminals. This happens not only when the battery is forcibly turned off but also in the standby mode as vanadium batteries do not include any metal plates to hold the chemical reactions / charges / voltages and can be fully drained when not in use.

If not fully drained, vanadium flow batteries are also unique in terms of short circuiting in that the internal dynamics of the battery are such that the energy discharge is limited to the fluid in the battery at any given time and the is typically less than 1% of the total stored energy. Therefore, together with the relatively low energy density of the vanadium electrolyte, the immediate release of energy, which occurs as a result of electrical shorting, is somewhat limited. The high heat capacity of the aqueous electrolyte is also beneficial in limiting the temperature rise.

Vanadium flow batteries have been tested under dead-short conditions resulting in normal operation with no danger to either equipment or personnel.

15.3.2.5 HAZARD – FIRE / DEFLAGRATION

Over 50% of the electrolyte solution is made up of water, which gives the electrolyte a non-flammable property. In the event of short circuiting, intense heat or high pressure, it is unlikely for the battery to catch fire. There is no “thermal runaway” risk when compared to other battery technologies.

Whilst some heat may be discharged from the battery, it will not be at a level that is deemed unsafe.

Like all other RFBs, VRFBs also have a battery management system. A battery management system ensures optimum and safe conditions for battery operation. Often a heat management system is integrated to avoid too high or too low temperatures.

15.3.2.6 HAZARD - HYDROGEN GENERATION

As with all other aqueous batteries, aqueous energy storage media from redox flow batteries are also subject to water limitations. In case of too high voltages or more precisely too high or too low half-cell potentials, the water is decomposed into its components, hydrogen and oxygen.

The generation of hydrogen in particular is often present as a very small but undesirable side reaction and causes a charge carrier imbalance between positive and negative half-cells, which leads to a slow loss of capacity. It also presents a fire / explosion hazard.

With VRFB, due to the flowability of the energy storage medium, the reaction products that would normally remain in the half-cell can be transported out of the cell and stored in separate tanks thus allowing the capability for a higher capacity than that attainable with conventional batteries. In addition, any deviations from safe operating parameters will trigger the shutdown of the system pumps ceasing to charge the electrolyte and thereby reducing the chances of accidental H₂ generation. In addition, the thermal mass of

the electrolyte tanks can provide an additional barrier to overcharging conditions by allowing ambient temperature during the discharge times to cool the VRFB for the next charge cycle.

15.3.2.7 HAZARD – WASTE ELECTROLYTE

Unfortunately, pentavalent vanadium ions have a tendency to react with each other, which leads to the formation of larger molecules which precipitate as solids and can thus damage the system. The reaction depends on the temperature and the concentration of VO₂⁺ (state of charge) but is also a function of the proton concentration. Temperature and concentrations therefore need to be controlled within specified ranges.

Should the concentration of undesirable components increase in the electrolyte, a part may need to be purged and replaced with fresh electrolyte. There may be facilities for regenerating purged electrolyte or it may have to be disposed of to a suitable hazardous waste facility.

15.3.2.8 HAZARD - ELECTROLYTE LEAKS

Leaks must be expected in any hazardous-fluid handling equipment. Secondary containment is typically designed into the system and standard corrosive PPE is required for handling liquid. Reliable leak detection, warning alarms, and containment is paramount. As with any chemicals plant, a suitable design with detection, alarm and trip instrumentation that has been subject to thorough Hazard and Operability Study (HAZOP) study should be in place, e.g., detection of dry running of pumps, detection of dead heading of pumps, prevention of reverse flow, detection of drop in tank levels etc.

15.3.3 OTHER CHEMICALS OR HAZARDS

The BESS is composed not only of the batteries, but also electrical connections, switches, power converters, cooling systems etc. The diagram below shows a typical complex system for a lithium solid state facility.

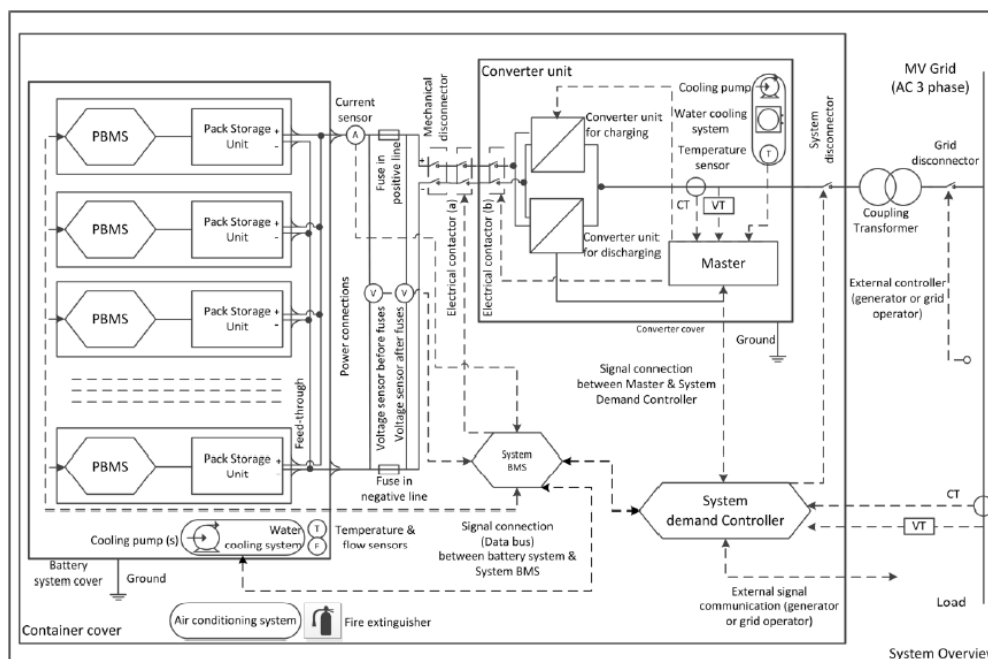

Source – STALLION reports

15.3.3.1 COOLING SYSTEMS

Due to the need to keep the batteries within a specified temperature range most of the containerized modular system have built-in air-conditioning systems while the VRFB building systems may have cooling water systems. Some have only fans for air cooling with filters to remove dust prior to cooling. Others, particularly those in hot environments requiring more cooling, may have refrigerant-based systems. These would have a refrigerant circuit usually containing non-flammable non-toxic refrigerant such as R134a (simple asphyxiant) etc as well as a low hazard circulating medium such as an ethylene glycol-based coolant. At high temperatures above 250 deg C R134 may decompose and may generate hydrogen fluoride and other toxic gases. Ethylene glycol is really only harmful if swallowed. In the environment it breaks down quickly and at low concentrations that would typically occur from occasional small spills, it has no toxicity.

15.3.3.2 FIRE SUPPRESSION SYSTEMS

Although these are only effective for some fire scenarios, some of the solid-state containerized systems come fitted with “Clean agent” fire suppressant systems. These are pressurized containers of powder/gases that are released into the container to snuff a fire and do not leave a residue on the equipment. Some containers have water sprinkler systems installed to quench thermal run-away reactions.

In general fire fighters may respond with water cannons/hydrants, foam systems etc. Such responses may generate large amount of contaminated and hazardous water runoff. A system to contain as much of this as possible should be in place.

15.3.3.3 GENERAL ELECTRICAL AND ELECTRONIC EQUIPMENT

Whatever the configuration of the battery containers/ buildings there will be electrical and electronic equipment in the battery compartment, the battery building as well as outside. In some installations the main electrical equipment such as the power conversion system is in a separate compartment separated by a fire wall. In others it can be in a separate container.

Wherever there is electrical equipment there is a possibility of shorting and overheating and fire.

15.3.4 PAST ACCIDENTS AND INCIDENTS RELEVANT TO BESS

The following events occurred with various types of batteries, e.g., solid state, and are included for the purpose of possible ideas on how things may go wrong with equipment around the batteries themselves:

1. There have been sodium-sulphur fires in Japanese installations. One such event was at the Tsukuba Plant, (Joso City, Ibaraki Prefecture) of Mitsubishi Materials Corporation where molten material leaked from a battery cell causing a short between battery cells in an adjoining block. As there was no fuse between cells the current continued to flow, with the whole battery module catching fire. Hot molten material melted the battery cell casings inside the battery overflowing to the modules below, causing the fire to spread further.
2. There have been exploding, melting Samsung smartphone lithium batteries.
3. A tesla electric battery powered car caught fire, see image below. Initially, a metal object penetrated the battery causing damage leading to short circuiting and thermal runaway. There was an alarm and the driver warned by on-board computer to park car safely and exit. The runaway did not propagate

to the other battery compartment due to separation measures installed. Fire fighters actually made the fire worse by their action to open the battery system to try and get water into it. This allowed air in and the flames to spread to the rest of the car. By way of comparison the American National Fire Protection Agency (NFPA) has stated that there are approximately 90 fires per billion kilometres driven with internal combustion engine cars as compared to the Tesla electric car with only 2 fires per billion driven kilometres.



Source STALLION Report

4. In 2010 a UPS Airlines cargo plane from Dubai crashed after a fire started in a large undeclared lithium battery shipment. Since not declared the batteries were not handled in any special manner as would be required if they were a declared hazardous load. There have been two other fires on flights containing lithium battery cargos. In all cases the fire went from small to uncontrolled in less than 30 minutes.
5. In 2013 the lithium batteries installed in two separate Air Japan Boeing 787 Dreamliners ignited resulting in fires, while on the ground in one case and in-flight in the other.
6. In August 2012, there was a fire at night at the Kahuku wind farm in Hawaii with an advanced lead-acid battery system installed indoors. The fire department were called several hours later and attempted, unsuccessfully to extinguish the fire with dry powder. The fire fighters faced thick smoke and could not enter the building for several hours because it was unclear whether the batteries were emitting toxic fumes.
7. In February 2012 during commission of a solar BESS in Arizona USA a fire started. The cause is unknown but the fire did not spread beyond the shipping container.
8. On 10 August 2016 in Wisconsin USA a fire started in the DC power control compartment of a BESS under construction. Fire department arrived and applied alcohol resistant foam to extinguish the fire. The fire did not spread to the batteries. As the system was in commissioning the fire suppression system in the PCS was not yet functional.
9. On 11 November 2017, a Lithium based BESS in Belgium caught fire during commissioning. Fitted fire detection and extinguishing system failed to contain the fire. The fire department were called and rapidly extinguished the fire preventing spreading to adjacent containers.



A fire engulfs a lithium-ion battery system at an Engie test site in Belgium, Nov. 11.

Photo Credit: Mr.JoostvanL/ YouTube

10. On 19 April 2019 there was an explosion at utility company Arizona Public Service's (APS) solar battery facility in Surprise, Arizona. The incident on April 19, 2019, started when there were reports at around 17:00 of smoke from the building housing the BESS. A few hours later, at approximately 20:04, an explosion occurred from inside the BESS. Nine people were injured. The factual conclusions reached by the investigation into the incident were:
- The suspected fire was actually an extensive cascading thermal runaway event, initiated by an internal cell failure within one battery cell in the BESS: cell pair 7, module 2, rack 15.
 - It is believed to a reasonable degree of scientific certainty that this internal failure was caused by an internal cell defect, specifically abnormal Lithium metal deposition and dendritic growth within the cell.
 - The total flooding clean agent fire suppression system installed in the BESS operated early in the incident and in accordance with its design. However, clean agent fire suppression systems are designed to extinguish incipient fires in ordinary combustibles. Such systems are not capable of preventing or stopping cascading thermal runaway in a BESS.
 - As a result, thermal runaway cascaded and propagated from cell 7-2 through every cell and module in Rack 15, via heat transfer. This propagation was facilitated by the absence of adequate thermal barrier protections between battery cells, which may have stopped or slowed the propagation of thermal runaway.
 - The uncontrolled cascading of thermal runaway from cell-to-cell and then module-to-module in Rack 15 led to the production of a large quantity of flammable gases within the BESS. Analysis and modelling from experts in this investigation confirmed that these gases were sufficient to create a flammable atmosphere within the BESS container.
 - Approximately three hours after thermal runaway began, the BESS door was opened by firefighters, agitating the remaining flammable gases, and allowing the gases to make contact with a heat source or spark. This led to the explosion.



Arizona utility APS has grounded its energy storage operations while the investigation continues.



Posted Tuesday, April 30, 2019 9:44 am

By Jason Stone & Matt Roy, Independent Newsmedia



Source DNV-GL McMicken Event Analysis

11. Records (By WoodMac) indicate that there are approximately 200 BESS systems in the USA and there have been 2 - 3 fires in the last 5 -10 years. This is an event frequency of 0.001 - 0.003 events per unit per year. DNV-GL in their quantitative risk analysis of BESS sites found that considering all the latest (2019) safety features the theoretical event frequency should be as low as 0.00001 events/unit/year i.e., 2 orders of magnitude lower than the actual values.
12. Korea has installed over 1200 energy storage systems as part of the clean energy programs. In December 2018 a lithium BESS caught fire at a cement plant in Jecheon. It was the 15th fire in 2018 in Korea. As of June 2019, there had been 23 fires at Korean facilities. The faults are reported to be with the incorrect installation of battery management systems, electrical systems and not due to the batteries themselves. Assuming these BESS systems have on average been in place for 5 years then the event frequency is approximately 0.004 events per unit per year. This correlates to the high value estimated for the USA data. This data is also two orders of magnitude higher than the DNV theoretical prediction on 0.00001 events/unit/year.
13. The Electric Power Research Institute (EPRI) of California USA maintains a list of Battery released accidents on its Wiki-Storage Page. The EPRI is an independent non-profit energy research, development and deployment organization that is funded by organizations around the world including the energy sector, academia and governments. The graphs and lists below summarize some of the incidents and the three accidents described in more below the table are typical of the types of accidents recorded.

ENVIRONMENTAL IMPACT ASSESSMENT REPORT: Scoping and Environmental Impact Assessment (EIA) Process for the Proposed Development of a Solar Photovoltaic (PV) Facility (Kudu Solar Facility 7) and associated infrastructure, near De Aar, Northern Cape Province

System Size ■ < 5MWh ■ 5 - 50 MWh ■ 50 MWh < ■ Unknown

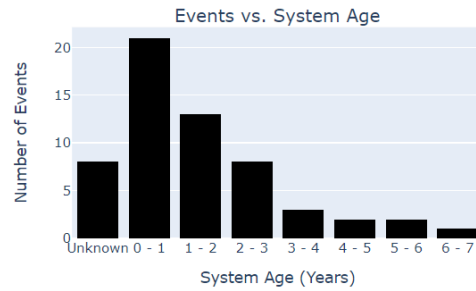
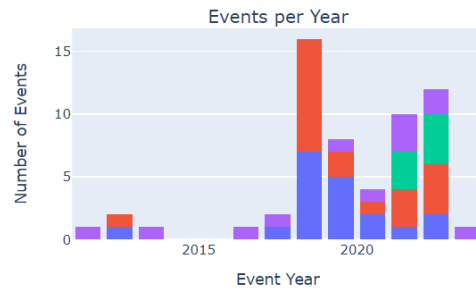
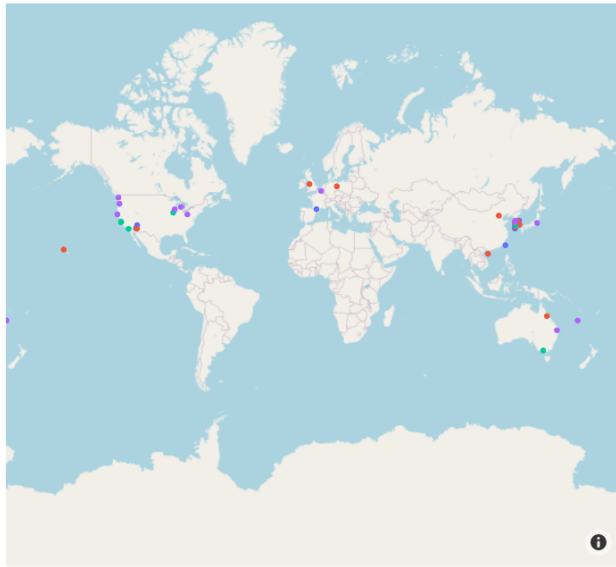

Location	Energy (MWh)	Power (MW)	Application	Installation	Event Date	System Age (yr)	State During Accident	Source	
US, PA, Millvale			Solar Integration	Urban	30 January 2023		Operational	WTAE	
South Korea, Jeollanam-do, Yeongam-gun, Geumjeong-myeon	251		Solar Integration	Rural	27 December 2022	1.8	Operational	E2News.com	
South Korea, Jeollanam-do, Damyang-gun, Mujeong-myeon, Deokgok-ri	9.1	2.5	Solar Integration	Rural	8 December 2022	5.5	Operational	E2News.com	
China, Hainan	50	25	Solar Integration		20 October 2022	0	Commissioning	china5e.com	
US, CA, Moss Landing	730	182.5	Energy Shifting, Ancillary Services	Substation	20 September 2022	0.5	Operational	KSBW News	
South Korea, Incheon		103	Energy Shifting	Factory	6 September 2022		Operational	Teller Report	
US, CA, Rio Dell			Solar Integration / Backup	Rural	3 August 2022	4	Operational	KRCR	
US, AZ, Chandler	40	10		Substation	18 April 2022	3	Operational	AZ Central	
US, CA, Valley Center	560	140		Substation	5 April 2022	0.2	Operational	Valley Road Runner	
Longjing, Taichung City, Taiwan	1	1	Solar Integration	Power Plant	30 March 2022	2	Operational	Economic Daily	
US, CA, Moss Landing	400	100	LG Energy Solution	Solar Integration	Power Plant	13 February 2022	1	Operational	KSBW News
South Korea, Gunwi-gun, Gyeongsangbuk-do	1.5	0.45	LG Energy Solution	Solar integration	Rural	17 January 2022	3	Operation. Fully charged	E2News
South Korea, Nam-gu, Ulsan	50	10	SK Innovation	Peak Load Reduction	Urban	12 January 2022	2	Operational	E2News
US, CA, Moss Landing	1,200	300	LG Energy Solution	Solar Integration	Power Plant	4 September 2021	0.8		Vistra
Australia, Victoria, Geelong	450	300	Tesla	Grid Stability	Rural	30 July 2021	0	Construction, Commissioning	ABC News
US, IL, LaSalle	72	72	LFP	Frequency Regulation	Rural	19 July 2021	1.6		The Times
Germany, Neuhausen	5	5	[LFP]	Solar Integration and Frequency Regulation	Indoor/Hangar	18 July 2021	5		RBB 24
Boulouparis, New Caledonia, France				Solar Integration	Rural	13 July 2021			FranceTVInfo.fr
US, MI, Standish				Demand Charge Mgmt	Substation	19 April 2021	0	Installation	WSGW
China, Beijing	25		Gotion High-Tech [LFP]	Solar Integration	Commerce Area	16 April 2021	2	Construction, Commissioning	CTIF Accident Analysis

- a) There have been three incidents at the Moss Landing Power plants PG&E battery storage facility in the USA where there are 256 TESLA Mega Packs installed. The latest involved one pack which caught alight and burned out five hours later. Firefighting approach was to let the pack burn out. Near-by communities were warned to shelter-in-place and the adjacent highway shutdown due to possible toxic smoke. Only one mega pack burned out and the fire did not spread.



- b) There was a small fire at the new Terra-Gen battery storage facility on Valley Centre Road USA. A small electrical failure produced some smoke which triggered the protection systems. Those worked exactly as planned and the failure was contained to a single battery module (meaning literally a single battery which is about the size of a DVD case). The safety systems worked exactly as planned and in addition the enclosure next to the one with the problem shut down because it also detected the smoke.
- c) The fire broke out during testing of a 13-tonne Tesla lithium megapack at the Victorian Big Battery site near Geelong Australia. A 13-tonne lithium battery was engulfed in flames, which then spread to an adjacent battery bank. This event indicates that if the battery pack units are not suitably separated the heat from one fire can set off an adjacent unit.



15.4. RISK ASSESSMENT

An analysis was undertaken to identify the failure events, their causes, consequences, as well as the preventative and mitigative measures in place on the proposed installation for all three phases of a typical project.

15.4.1 SOLID STATE LITHIUM-ION BATTERY ENERGY STORAGE SYSTEMS

TABLE 15.4.1.1 - CONSTRUCTION PHASE (Excluding commissioning which involves starting and testing the installed equipment, i.e. powering up the batteries)

Impact number	Receptor	Description	Stage	Character	Preventative and Mitigative Measures	Ease of Mitigation	Raw Risk						Residual Risk					
							(M+	E+	R+	D)x	P=	S	(M+	E+	R+	D)x	P=	S
Impact 1:	Human Health - chronic exposure to toxic chemical or biological agents	Causes - Construction materials such as cement, paints, solvents, welding fumes, truck fumes etc. Consequences - Employee / contractor illness.	Construction	Negative	The construction phase will be managed according to all the requirements of the Occupational Health and Safety Act 85 of 1993 specifically the Construction Regulations. SHEQ policy in place. A detailed construction Risk Assessment to be undertaken prior to work. SHE procedure in place. PPE to be specified. SHE appointees in place. Contractor's safety files in place and up to date. All necessary health controls/ practices to be in place, e.g., ventilation of welding and painting areas. SHE monitoring and reporting programs in place. Emergency response plan to be in place prior to beginning construction and to include aspects such as appointment of emergency controller, provision of first aid, first responder contact numbers.	Moderate	3	1	3	4	4	44	1	1	3	4	2	18
Impact 2:	Human Health - exposure to noise	Causes - Drilling, piling, generators, air compressors. Consequences - Adverse impact on hearing of workers. Possible nuisance factor in near-by areas.	Construction	Negative	OHS Act Noise Induced Hearing Loss Regulations. Health Risk Assessment to determine if equipment noise exceeds 85dB at workstation and 61dB at boundary of the site. Employees to be provided with hearing protection if working near equipment that exceeds the noise limits.	Easy	3	1	5	5	4	56	2	1	5	5	2	26

ENVIRONMENTAL IMPACT ASSESSMENT REPORT: Scoping and Environmental Impact Assessment (EIA) Process for the Proposed Development of a Solar Photovoltaic (PV) Facility
(Kudu Solar Facility 7) and associated infrastructure, near De Aar, Northern Cape Province

Impact number	Receptor	Description	Stage	Character	Preventative and Mitigative Measures	Ease of Mitigation	Raw Risk						Residual Risk					
							(M+	E+	R+	D)x	P=	S	(M+	E+	R+	D)x	P=	S
Impact 3:	Human Health - exposure to temperature extremes and/or humidity	Causes - Heat during the day. Cold in winter. Consequence - Heat stroke. Hypothermia.	Construction	Negative	Construction site facilities to comply with Occupational Health and Safety Act 85 of 1993, specifically the thermal, humidity, lighting and ventilation requirements of the Environmental Regulations for Workplaces. Adequate potable water for employees to be provided during all phases of the project. Bore hole, bowser and tank or small water treatment plant may be required to provide potable water for the BESS installation staff during all phases of the project. Geohydrology Assessment has been conducted during the EIA Phase to assess the impact of the use of groundwater.	Easy	3	2	3	1	2	18	2	2	3	1	1	8
							Significance						N2 - Low					
Impact 4:	Human Health - exposure to psychological stress	Causes - Large projects bring many contractor workers into a small, isolated community. Consequences – Lack of sufficient accommodation, entertainment etc. Increase in alcohol abuse, violence	Construction	Negative	Refer to the Socio-Economic Specialist Study undertaken as part of the EIA for this project.	Easy	2	3	3	2	2	20	2	3	3	2	2	20
							Significance						N2 - Low					
Impact 5:	Human Health – exposure to ergonomic stress	Causes – Lifting heavy equipment. Awkward angles during construction. Consequences – Back and other injuries.	Construction	Negative	Training in lifting techniques. Ensure that despite the isolated location all the necessary equipment is available (and well maintained) during construction. Otherwise, employees may revert to unsafe practices. Ensure this is in place prior to project commencement Ensure first aid provision on site.	Moderate	4	1	3	2	3	30	4	1	3	2	2	20
							Significance						N2 - Low					

ENVIRONMENTAL IMPACT ASSESSMENT REPORT: Scoping and Environmental Impact Assessment (EIA) Process for the Proposed Development of a Solar Photovoltaic (PV) Facility
(Kudu Solar Facility 7) and associated infrastructure, near De Aar, Northern Cape Province

Impact number	Receptor	Description	Stage	Character	Preventative and Mitigative Measures	Ease of Mitigation	Raw Risk						Residual Risk					
							(M+	E+	R+	D)x	P=	S	(M+	E+	R+	D)x	P=	S
Impact 6a:	Human and Equipment Safety - exposure to fire radiation	Causes – Involvement in an external fire. Fire involving fuels used in construction vehicles or vehicles themselves (e.g., tyre fire). Fire due to uncontrolled welding or other hot-work Consequences - Injuries due to radiation especially amongst first responders and bystanders. Fatalities unlikely from the heat radiation as not highly flammable nor massive fire.	Construction	Negative	Fuels stored on site in dedicated, demarcated and banded areas. Suitable fire-fighting equipment on site near source of fuel, e.g., diesel tank, generators, mess, workshops etc. The company responsible for the facility at this stage is to have: 1. Emergency plan to be in place prior to commencement of construction. 2. Fuel spill containment procedures and equipment to be in place. 3. Hot-work permit and management system to be in place.	Complex	4	2	3	5	4	56	4	2	3	5	2	28
							Significance						N3 - Moderate					

ENVIRONMENTAL IMPACT ASSESSMENT REPORT: Scoping and Environmental Impact Assessment (EIA) Process for the Proposed Development of a Solar Photovoltaic (PV) Facility (Kudu Solar Facility 7) and associated infrastructure, near De Aar, Northern Cape Province

Impact number	Receptor	Description	Stage	Character	Preventative and Mitigative Measures	Ease of Mitigation	Raw Risk						Residual Risk					
							(M+)	E+	R+	D)x	P=	S	(M+)	E+	R+	D)x	P=	S
Impact 6b:	Human and Equipment Safety - exposure to fire radiation	<p>Causes - Solid state battery containers damaged on route e.g., dropped in port (drops do happen about 1/2000 containers) and importing possibly up to 700 containers for the site. With this it is possible, although unlikely, that one will be dropped, traffic accident on-route. Involvement in an external fire e.g., at the port or on route. Data indicates installed facility events are 0.001/year. Transport of 700 units per installation assumed to take 4 weeks each so f= 0.05 - once in 20 years so likelihood is moderate.</p> <p>Consequences – Injuries due to radiation especially amongst first responders and bystanders. Fatalities unlikely from the heat radiation as not highly flammable nor massive fire (refer to noxious smoke in</p>	Construction	Negative	<p>Solid state battery design includes abuse tests such as drop test, impact, rapid discharge etc. Propagation tests for systems, e.g., heat insulating materials between cells/modules. Factory acceptance test prior to prior to leaving manufacture. Batteries are usually stored at 50% charge to prolong life but may be shipped fully discharged. This level of detail should be understood so as to assess the risk during transport and storage.</p> <p>The company responsible for the battery installation should ensure suitably competent transport companies are appointed. The company responsible for transportation should ensure:</p> <ul style="list-style-type: none"> - Compliance with National Road Traffic Act regulation 8 – dangerous goods. - Port Authorities should be alerted to the overall project and the hazardous nature of the contents of battery containers being imported. Note. If, as per one of the typical suppliers (Tesla) indications, the containers are classified as IMDG Class 9 – the containers will not receive any special care in the ports and may be stored next to flammables. Port emergency response in particular need training on mitigating battery hazards. <p>Prior to bringing any containers into the country, the company responsible for the battery installation (possibly via appointed contractors) should ensure that an Emergency response plan is in place for the full route from the ship to the site. Drivers trained in the hazards of containerized batteries.</p> <p>The Emergency response plan must determine and address:</p> <ul style="list-style-type: none"> - What gases would be released in a fire and are there inhalation hazards. - Extinguishing has two important elements, put out fire and to provide cooling. Different approaches may be needed for small fire – e.g., put out, and for large fires e.g., cool with copious quantities of water. Note inert gases and foam may put out the initial fire but fail to control thermal runaway or to cool the batteries 	Complex	5	2	5	5	4	68	5	2	5	5	1	17

ENVIRONMENTAL IMPACT ASSESSMENT REPORT: Scoping and Environmental Impact Assessment (EIA) Process for the Proposed Development of a Solar Photovoltaic (PV) Facility
(Kudu Solar Facility 7) and associated infrastructure, near De Aar, Northern Cape Province

Impact number	Receptor	Description	Stage	Character	Preventative and Mitigative Measures	Ease of Mitigation	Raw Risk						Residual Risk					
							(M+	E+	R+	(D)x	P=	S	(M+	E+	R+	(D)x	P=	S
		APPENDIX A below for the major impact).			<ul style="list-style-type: none"> - resulting in reignition. - What initial fire extinguishing medium should be used. - Whether there are any secondary gases or residues from use of extinguishers. - If water is appropriate, determine if the system needs outside connections to sprinklers inside the container. - First responders need to know what media to use, especially if water totally unsuitable and if there are no connection points for water etc. - Must the container be left unopened or opened. - PPE to be specified including possible exposure to chemicals and fumes as well as radiate heat. - Containment of residues/water/damaged equipment. - Suitable safe making and disposal plan for after the event i.e. how do responders deal with partially charged damage units, contaminated surfaces (e.g., HF residues). 													
Significance							N4 - High						N2 - Low					
Impact 7:	Human and Equipment Safety - exposure to explosion over pressures	Causes - With solid state lithium containers, flammable gases generated by thermal run away reach explosive limits. Ignition on hot surfaces, static. Consequences - Potential fatalities amongst first responders. Damage to container, transport truck or other nearby items, e.g., other container in the port.	Construction	Negative	<p>During transport this is only likely to happen due to possible inappropriate emergency response, e.g., opening containers when they may be the type that should be left to burn out.</p> <p>For simplicity one transport route would be preferable. The route needs to be assessed in terms of responding local services, rest places for drivers, refuelling if required, break down services available etc.</p> <p>Once an import route has been chosen, e.g., N10 from Port of Ngqura, then the appointed transport company should ensure key emergency services on route could be given awareness training in battery fire/accident response. Emergency response planning and training referred to above may be important for key locations such as the mountain passes / tunnels.</p>	N/A	5	4	5	5	3	57	5	4	5	5	1	19
Significance							N3 - Moderate						N2 - Low					

ENVIRONMENTAL IMPACT ASSESSMENT REPORT: Scoping and Environmental Impact Assessment (EIA) Process for the Proposed Development of a Solar Photovoltaic (PV) Facility (Kudu Solar Facility 7) and associated infrastructure, near De Aar, Northern Cape Province

Impact number	Receptor	Description	Stage	Character	Preventative and Mitigative Measures	Ease of Mitigation	Raw Risk						Residual Risk					
							(M+	E+	R+	D)x	P=	S	(M+	E+	R+	D)x	P=	S
Impact 8a:	Human and Equipment Safety - exposure to acute toxic chemical and biological agents	Causes Human pathogens and diseases, sewage, food waste. Snakes, insects, wild and domesticated animals and harmful plants. Consequences - Illness and at worst without mitigation, possibly extending to fatalities. Effects can vary from discomfort to fatalities for venomous snakes or bee swarms etc.	Construction	Negative	<p>All necessary good hygiene practices to be in place, e.g., provision of sanitation facilities, eating areas, infectious disease controls.</p> <p>Policies and practice for dealing with known vectors of disease such as AIDS, TB, COVID 19 and others. Awareness training for persons on site, safety induction to include animal hazards.</p> <p>First aid and emergency response to consider the necessary anti-venom, anti-histamines, topical medicines etc.</p> <p>Due to isolated locations some distance from town, the ability to treat with anti-venom and extreme allergic reactions on site is critical to mitigate the impacts.</p>	Complex	4	2	3	2	3	33	3	2	3	2	2	20
							Significance						N3 - Moderate			N2 - Low		

ENVIRONMENTAL IMPACT ASSESSMENT REPORT: Scoping and Environmental Impact Assessment (EIA) Process for the Proposed Development of a Solar Photovoltaic (PV) Facility
(Kudu Solar Facility 7) and associated infrastructure, near De Aar, Northern Cape Province

Impact number	Receptor	Description	Stage	Character	Preventative and Mitigative Measures	Ease of Mitigation	(M+	E+	R+	D)x	P=	S	(M+	E+	R+	D)x	P=	S
							Raw Risk						Residual Risk					
Impact 8b:	Human and Equipment Safety - exposure to acute toxic chemical and biological agents	<p>Causes - Damaged solid-state batteries release fumes, leak electrolyte, are completely broken exposing hazardous chemicals. Thermal runaway and hazardous fumes released.</p> <p>Consequences - Impacts can vary from mild skin irritation from exposure to small leaks to serious corrosive burns or lung damage.</p>	Construction	Negative	<p>Appointed transport company to ensure transport in accordance with Regulation 8 of the National Road Traffic Act 93 of 1996, Dangerous Goods. Not permitted to transport prescribed goods in manner not consistent with the prescriptions, e.g., consignor and consignee responsibilities. Prescription found in SANS 10228/29 and international codes for battery transport etc.</p> <p>Transportation of BESS components in sealed packages that are kept upright, protected from movement damage etc.</p> <p>Also packaged to ensure no short-circuiting during transport.</p> <p>Transport to prevent excessive vibration considerations as battery internal components may be damaged leading to thermal run-away during commissioning.</p> <p>Pre-assembled containers will most likely be supplied. These will be fitted with the necessary protective measures by the supplier considering marine and road transport as well as lifting, setting down etc.</p> <p>Route selection to consider possible incidents along the way and suitable response, e.g., satellite tracking, mobile communication, 24/7 helpline response.</p> <p>Standard dangerous goods requirements for Hazmat labels, Transport Emergency Data i.e. Trem cards, driver trained in the hazards of the load.</p> <p>Likelihood similar to fire above.</p>	Complex	4	3	3	5	3	45	4	3	3	5	2	30
							Significance						N3 - Moderate					

ENVIRONMENTAL IMPACT ASSESSMENT REPORT: Scoping and Environmental Impact Assessment (EIA) Process for the Proposed Development of a Solar Photovoltaic (PV) Facility (Kudu Solar Facility 7) and associated infrastructure, near De Aar, Northern Cape Province

Impact number	Receptor	Description	Stage	Character	Preventative and Mitigative Measures	Ease of Mitigation	Raw Risk						Residual Risk					
							(M+	E+	R+	D)x	P=	S	(M+	E+	R+	D)x	P=	S
Impact 9:	Human and Equipment Safety - exposure to violent release of kinetic or potential energy	Causes - Construction moving equipment, heavy loaded, elevated loads, working at heights Consequences - Injury or possibly fatality. Damage to equipment. Delays in starting the project, financial losses	Construction	Negative	<p>The construction phase will be managed according to all the requirements of the Occupational Health and Safety Act 85 of 1993 specifically the Construction Regulations.</p> <p>SHEQ policy in place.</p> <p>A detailed construction Risk Assessment to be undertaken prior to work.</p> <p>SHE procedure in place.</p> <p>PPE to be specified.</p> <p>SHE appointees in place.</p> <p>Contractors safety files in place and up to date.</p> <p>SHE monitoring and reporting programs in place.</p> <p>Standard construction site rules regarding traffic, reversing sirens, rigging controls, cordoning off excavations etc.</p> <p>Civil and building structures to comply with the National Building Regulations and building Standards Act 103 of 1977, SANS 10400 and other relevant codes.</p> <p>Other constructions such as roads, sewers etc also to comply with relevant SANS standards.</p> <p>All normal procedures for working at heights, hot work permits, confined space entry, cordon off excavations etc to be in place before construction begins.</p> <p>Emergency response plan to be in place before construction begins.</p>	Complex	5	1	5	5	4	64	5	1	5	5	1	16
Impact 10:	Human and Equipment Safety - exposure to electromagnetic waves	Causes - Use of electrical machines, generators etc. Hot dry area static generation is highly likely. Lightning strike. Consequences - Electrocutation. Ignition and burns. Injury and death. Damage to electrical equipment.	Construction	Negative	<p>Standard maintenance of condition of electrical equipment and safe operating instructions.</p> <p>Ability to shut off power to systems in use on site.</p> <p>If persons are decanting fuels or dealing with other highly flammable materials care should be taken regarding possible static discharge, and installations to be suitably designed and maintained.</p> <p>Lightning strike rate in the study area is moderately low.</p> <p>Outside work must be stopped during thunderstorms.</p>	Complex	5	2	5	5	3	51	5	2	5	5	1	17

ENVIRONMENTAL IMPACT ASSESSMENT REPORT: Scoping and Environmental Impact Assessment (EIA) Process for the Proposed Development of a Solar Photovoltaic (PV) Facility
(Kudu Solar Facility 7) and associated infrastructure, near De Aar, Northern Cape Province

Impact number	Receptor	Description	Stage	Character	Preventative and Mitigative Measures	Ease of Mitigation	Raw Risk						Residual Risk							
							(M+	E+	R+	D)x	P=	S	(M+	E+	R+	D)x	P=	S		
					Lighting conductors may be required for the final installation, to be confirmed during design phase.															
						Significance	N3 - Moderate						N2 - Low							
Impact 11:	Environment - emissions to air	Causes - Dust from construction and generally hot dry area. Consequences - Adverse impact on employee health.	Construction	Negative	May need to use dampening on roads etc. as per normal construction practices. May need PPE (dust masks) for specific construction workers.	Easy	3	2	1	1	4	28	2	2	1	1	2	12		
						Significance	N2 - Low						N1 - Very Low							
Impact 12:	Environment - emissions to water	Causes - Diesel for equipment, paints and solvents. Transformer oil spills. Sewage and kitchen/mess area wastewater. Consequences - Environmental damage, particularly to the surface and underground water in the area.	Construction	Negative	Normal construction site practices for preventing and containing fuels/paint/oil etc spills. Bunding under any temporary tanks, curbing under truck offloading areas and sealed surfaces (e.g., concrete) under truck parking area is particularly important. Spill clean-up procedures to be in place before commencing construction. Sewage and any kitchen liquids - containment and suitable treatment/disposal	Moderate	2	2	3	2	3	27	2	2	3	2	2	18		
						Significance	N2 - Low						N2 - Low							

ENVIRONMENTAL IMPACT ASSESSMENT REPORT: Scoping and Environmental Impact Assessment (EIA) Process for the Proposed Development of a Solar Photovoltaic (PV) Facility
(Kudu Solar Facility 7) and associated infrastructure, near De Aar, Northern Cape Province

Impact number	Receptor	Description	Stage	Character	Preventative and Mitigative Measures	Ease of Mitigation	(M+	E+	R+	D)x	P=	S	(M+	E+	R+	D)x	P=	S
							Raw Risk						Residual Risk					
Impact 13:	Environment - emissions to earth	Causes - Mess area and other solid waste. Consequences - Environmental damage.	Construction	Negative	There will be packaging materials that will need to be disposed of after the entire system is connected and commissioned as well as after regular maintenance. There will need to be waste segregation (e.g., electronic equipment, chemicals) and management on the site.	Easy	2	2	3	3	3	30	1	2	3	3	2	18
						Significance	N2 - Low						N2 - Low					
Impact 14:	Environment - waste of resources e.g., water, power etc	Causes - Water usage not controlled. Battery containers damaged. Consequences - Delays.	Construction	Negative	Water usage to be monitored on site during construction. Handling protocols to be provided by battery supplier. End of Life plan needs to be in place before any battery containers enter the country as there may be damaged battery unit from day 1. Water management plan and spill containment plans to be in place.	Easy	1	1	1	2	4	20	1	1	1	2	2	10
							N2 - Low						N1 - Very Low					
Impact 15:	Public - Aesthetics	Causes - Bright surfaces reflecting light. Tall structures in a flat area. Consequences - Irritation.	Construction	Negative	Refer to the visual impact assessment undertaken as part of the EIA.	Moderate	2	2	3	3	3	30	2	2	3	3	3	30
						Significance	N2 - Low						N2 - Low					
Impact 16:	Investors - Financial	Causes - Defective technology. Extreme project delays. Consequences - Financial loss	Construction	Negative	Design by experienced contractors using internationally recognized and proven technology. Project management with deviation monitoring.	Moderate	5	1	3	4	3	39	3	1	3	4	2	22
						Significance	N3 - Moderate						N2 - Low					

ENVIRONMENTAL IMPACT ASSESSMENT REPORT: Scoping and Environmental Impact Assessment (EIA) Process for the Proposed Development of a Solar Photovoltaic (PV) Facility (Kudu Solar Facility 7) and associated infrastructure, near De Aar, Northern Cape Province

Impact number	Receptor	Description	Stage	Character	Preventative and Mitigative Measures	Ease of Mitigation	Raw Risk						Residual Risk					
							(M+	E+	R+	D)x	P=	S	(M+	E+	R+	D)x	P=	S
Impact 17:	Employees and investors - Security	Causes - On route, potential hi-jacking of valuable but hazardous load. On site, theft of construction equipment and battery installation facilities. Civil unrest or violent strike by employees. Consequences - Theft. Injury to burglars. Damage to equipment possibly setting off thermal runaway.	Construction	Negative	Fencing around electrical infrastructure to SANS standard and Eskom Guidelines. The hazardous nature of the electrical and battery equipment should be clearly indicated – e.g., Skull and Cross Bones or other signs. Isolated location both helps and hinders security. Night lighting to be provided both indoors and outdoors where necessary.	Complex	4	1	3	2	4	40	3	1	3	2	3	27
							Significance						N3 - Moderate			N2 - Low		
Impact 18:	Emergencies	Causes - Fires, explosions, toxic smoke, large spills, traffic accidents, equipment/structural collapse. Inadequate emergency response to small event leads to escalation. Consequences - Injuries turn to fatalities, small losses become extended down time.	Construction	Negative	All safety measures listed above. Emergency procedures need to be practiced prior to commencement of construction. If batteries are stored at 50% charge, thermal run away can happen while in storage on site waiting for installation. In addition, if involved in an external fire thermal run away can happen even with uncharged batteries. Except during shipping, ideally the units should not be stored any closer to each other than they would be in the final installation so that propagation is prevented, i.e. laydown area needs to be considered. The company in charge of the containers at each stage in the transport process needs to be very clear so that responsibility for the integrity of the load and protection of the persons involved in transfer and coordination of emergency response on-route. E.g., if purchased from Tesla where does hand over occur to the South African contractor / owner, at the factory door in USA, at the port in RSA, at the site fence. For	Complex	4	2	3	5	4	56	4	2	3	5	2	28

ENVIRONMENTAL IMPACT ASSESSMENT REPORT: Scoping and Environmental Impact Assessment (EIA) Process for the Proposed Development of a Solar Photovoltaic (PV) Facility (Kudu Solar Facility 7) and associated infrastructure, near De Aar, Northern Cape Province

Impact number	Receptor	Description	Stage	Character	Preventative and Mitigative Measures	Ease of Mitigation	Raw Risk						Residual Risk						
							(M+	E+	R+	D)x	P=	S	(M+	E+	R+	D)x	P=	S	
					example, who will be accountable if there's thermal runaway event on a truck with a container that stops in a small town for driver refreshments.														
Significance							N3 - Moderate						N2 - Low						
Impact 19:	Investors - Legal	Causes - Battery field is evolving quickly with new guides, codes and regulations happening at the same time as evolving technology. Consequences - Unknown hazards manifest due to using "cheaper supplier or less developed technology".	Construction	Negative	Use only internationally reputable battery suppliers who comply with all known regulations/guideline at the time of purchasing. Where reasonably practicable ensure only "state of the art" battery systems are used and not old technologies prone to fires/explosions etc.	Moderate	3	1	3	3	4	40	2	1	3	3	2	18	
Significance							N3 - Moderate						N2 - Low						

The above Risk Assessment shows that provided the preventative and mitigative measures are incorporated, the construction phase of the project does not present any high risks nor any fatal flaws. The average raw risk significance is rated as moderate, and the average residual risk is rated as low.

TABLE 15.4.1.2 - OPERATIONAL PHASE (Including Commissioning – i.e. initial testing of the systems and first powerup of batteries)

From the details of accidents that have happened both with BESS installations and chemical plants in general, it is clear that many potential problems manifest during the commissioning phase when units are first powered up to test functionality. This phase is critical and all controls, procedures, mitigation measures etc that would be in place for full operation should be in place before commissioning commences.

Impact number	Receptor	Description	Stage	Character	Preventative and Mitigative Measures	Ease of Mitigation	Raw Risk						Residual Risk					
							(M+	E+	R+	D)x	P=	S	(M+	E+	R+	D)x	P=	S
Impact 1a:	Human Health - chronic exposure to toxic chemical or biological agents	Causes - Operation and maintenance materials spare parts, paints, solvents, welding fumes, transformers oils, lubricating oils and greases etc. Consequences - Occupational illness.	Operation	Negative	<p>The operation and maintenance phase will be managed according to all the requirements of the Occupational Health and Safety Act 85 of 1993. SHEQ policy in place.</p> <p>A detailed Risk Assessment of all normal operating and maintenance activities on site to be compiled, and form the basis of operating instructions, prior to commencing commissioning.</p> <p>SHE procedure in place, e.g., PPE specified, management of change, integrity monitoring. SHE appointees in place.</p> <p>Training of staff in general hazards on site.</p> <p>All necessary health controls/ practices to be in place, e.g., ventilation of confined areas, occupational health monitoring if required and reporting programs in place.</p> <p>Emergency response plan for full operation and maintenance phase to be in place prior to beginning commissioning and to include aspects such as:</p> <ul style="list-style-type: none"> - appointment of emergency controller, - emergency isolation systems for electricity, - emergency isolation and containment systems for electrolyte, - provision of PPE for hazardous materials response, - provision of emergency facilities for staff at the main office building, - provision of first aid facilities, - first responder contact numbers etc. 	Easy	2	1	3	4	5	50	1	1	3	4	2	18
							Significance						N3 - Moderate					

ENVIRONMENTAL IMPACT ASSESSMENT REPORT: Scoping and Environmental Impact Assessment (EIA) Process for the Proposed Development of a Solar Photovoltaic (PV) Facility (Kudu Solar Facility 7) and associated infrastructure, near De Aar, Northern Cape Province

Impact number	Receptor	Description	Stage	Character	Preventative and Mitigative Measures	Ease of Mitigation	Raw Risk						Residual Risk					
							(M+	E+	R+	D)x	P=	S	(M+	E+	R+	D)x	P=	S
Impact 1b:	Human Health - chronic exposure to toxic chemical or biological agents	Causes - Compromised battery compartments vapours accumulate in the containers, solids/liquids on surfaces. Maintenance of battery components, corrosive and mildly toxic liquid on surfaces. Consequences - Dermatitis, skin /eye/lung irritation.	Operation	Negative	Solid state batteries sealed, individual batteries in modules which are also sealed, pre-packed in the container. Maintenance procedures will be in place should equipment need to be opened, e.g., pumps drained and decontaminated prior to repair in workshop etc. PPE will be specified for handling battery parts and other equipment on site. Training of staff in hazards of chemicals on site. Possible detectors with local alarms if regulated occupational exposure limits are exceeded etc prior to entry for inspection of battery containers. Labelling of all equipment. Confined space entry procedures if entering tanks. There needs to be careful thought given to procedures to be adopted before entering into the BESS or a container particularly after a Battery management System (BMS) shut down where there may be flammable or toxic gases present, a fire etc. Safety Data Sheets (SDSs) to be available on site. Operating manuals to be provided including start-up, shut-down, steady state, monitoring requirements. Maintenance manuals with make safe, decontamination and repair procedures. Proposed maintenance schedules e.g., checklists for weekly, monthly, annual etc. Provided portable equipment for calibration and for testing/verification of defective equipment, e.g., volt/current meters, infrared camera	Complex	3	1	3	5	4	48	1	1	3	5	2	20
Impact 2:	Human Health - exposure to noise	Causes - Moving parts inside containers, buildings, pumps, compressors, cooling systems etc. Consequences - Adverse impact on hearing of workers. Nuisance factor at	Operation	Negative	Design to ensure continuous noise does not exceed 85dB within the facilities or at any other location on site or 61 dB at the site boundary, e.g., emergency generator, air compressor etc. Employees to be provided with hearing protection if working near equipment that exceeds the noise limits.	Easy	2	1	5	5	4	52	2	1	5	5	2	26

ENVIRONMENTAL IMPACT ASSESSMENT REPORT: Scoping and Environmental Impact Assessment (EIA) Process for the Proposed Development of a Solar Photovoltaic (PV) Facility
(Kudu Solar Facility 7) and associated infrastructure, near De Aar, Northern Cape Province

Impact number	Receptor	Description	Stage	Character	Preventative and Mitigative Measures	Ease of Mitigation	Raw Risk						Residual Risk					
							(M+	E+	R+	D)x	P=	S	(M+	E+	R+	D)x	P=	S
		near-by residences or other activities.																
						Significance	N3 - Moderate						N2 - Low					
Impact 3:	Human Health - exposure to temperature extremes and/or humidity	Causes - Heat during the day. Batteries generate heat within enclosed building / containers. Cold in winter. Night work requires lighting. Consequences - Heat stroke. Hypothermia.	Operation	Negative	Building and container facilities to comply with Occupational Health and Safety Act 85 of 1993 specifically the thermal, humidity, lighting and ventilation requirements of the Environmental Regulations for Workplaces. Ensure containers are temperature controlled as required to remain within the optimal battery operating temperature range. Lighting to be provided inside any buildings, inside the containers, possibly linked to the door opening and outdoors where necessary. Adequate potable water to be provided during all phases of the project. Suitable lighting to be provided including emergency lighting for safe building exit in the event of power failure. PPE for operations and maintenance staff to be suitable for the weather conditions.	Easy	4	2	3	1	2	20	3	2	3	1	1	9
						Significance	N2 - Low						N1 - Very Low					
Impact 4:	Human Health - exposure to psychological stress	Causes - Isolated workstation and monotonous repetitive work. Consequences - Low performance, system productivity suffers.	Operation	Negative	Staff rotation to other activities within the site may be necessary. Performance monitoring of inspections / maintenance tasks in particular will be necessary.	Easy	2	3	3	2	2	20	1	3	3	2	1	9
						Significance	N2 - Low						N1 - Very Low					

ENVIRONMENTAL IMPACT ASSESSMENT REPORT: Scoping and Environmental Impact Assessment (EIA) Process for the Proposed Development of a Solar Photovoltaic (PV) Facility (Kudu Solar Facility 7) and associated infrastructure, near De Aar, Northern Cape Province

Impact number	Receptor	Description	Stage	Character	Preventative and Mitigative Measures	Ease of Mitigation	Raw Risk						Residual Risk					
							(M+	E+	R+	D)x	P=	S	(M+	E+	R+	D)x	P=	S
Impact 5:	Human Health - exposure to ergonomic stress	Causes - Lifting heavy equipment. Awkward angles during maintenance, stretching reaching to high level and bending to low level. Working at height if equipment located on top of roofs or elevated electrical equipment (e.g., pylons). Consequences - Back and other injuries.	Operation	Negative	Training in lifting techniques. Training in working at heights. If equipment is at height (see OHS Act General Safety Regulation 6), ensure suitable safe (electrically and physically) ladders / harnesses etc. are available. Working at height procedure to be in place.	Easy	5	1	3	2	3	33	4	1	3	2	2	20
							Significance						N3 - Moderate					

ENVIRONMENTAL IMPACT ASSESSMENT REPORT: Scoping and Environmental Impact Assessment (EIA) Process for the Proposed Development of a Solar Photovoltaic (PV) Facility
(Kudu Solar Facility 7) and associated infrastructure, near De Aar, Northern Cape Province

<p>Impact 6a:</p>	<p>Human and Equipment Safety - exposure to fire radiation</p>	<p>Causes – Involvement in an external fire e.g., veld fire, maintenance vehicle fire, electrical systems fire. Manufacturing defects or damage to battery leading to shorting and heating. High humidity condensation of water or ingress of water or flooding leading to shorting. Dust accumulation on electrical parts leading to overheating. Excessive electrical loads - surges Operator abuse BMS failure or software failure. Incorrect extinguishing medium, escalate the fire. Consequences - Contaminated run off. Radiation burns unlikely to be severe as no highly flammable materials on site. Damaged equipment. Fire spreads to other units or offsite if grass/vegetation not controlled.</p>	<p>Operation</p>	<p>Negative</p>	<p>Grass cutting and fire breaks around the BESS installations to prevent veld fires. No combustible materials to be stored in or near the batteries or electrical infrastructure. Separation of site diesel tank, transformers from BESS and vice versa. Suggested minimum separation from substation is 20m.</p> <p>There are BESS design codes from the USA and standards of practice that can be used e.g., UL9540, NFPA 855 and DNV GL RP 43.</p> <p>Detailed Failure Modes and Effect Analysis (FMEA)/Hazop/Bowtie to be done during design at the component level and system levels. Safety integrity level rating of equipment (failure probably) with suitable redundancy if required. Site Acceptance Testing as part of commissioning of each unit and the overall system. Abuse tests conducted by supplier. BMS should be checking individual cell voltage as well as stack, module, container, system voltages/current etc. BMS tripping the cell and possibly the stack/building unit or module/rack/container, if variations in voltage. Diagnostics easily accessible. Diagnostics able to distinguish cell from stack or cell from module faults. Protective systems are only as good as their reliability and functionality testing is important, e.g., testing that all battery trips actually work. Fire resistant barrier between the batteries and the PCS side if in the same container, or separate containers. Suitable ingress protection level provided for electrical equipment, e.g., IP55 - 66. If air cooling into container, suitable dust filters to be provided. Smoke detectors linked to BMS & alerts in control room. Effects of battery aging to be considered. Solid state battery life starts to be impacted above 40 deg C and significant impacts above 50 deg C with thermal run away starting at 65-70 deg C. BMS trips system at 50 deg C. Temperature monitoring to be in place. Regular infrared scanning. Data needs to be stored for trend analysis.</p> <p>Data indicates an event frequency of 0.001 per installation and with up to 700 units this would mean an event once 2 years, i.e. a high probability event. Most events will be small not resulting in injuries, but this is possible if the event is not controlled.</p>	<p>Complex</p>	<p>5</p>	<p>1</p>	<p>5</p>	<p>5</p>	<p>4</p>	<p>64</p>	<p>5</p>	<p>1</p>	<p>5</p>	<p>5</p>	<p>1</p>	<p>16</p>
--------------------------	--	--	------------------	-----------------	--	----------------	----------	----------	----------	----------	----------	------------------	----------	----------	----------	----------	----------	------------------

ENVIRONMENTAL IMPACT ASSESSMENT REPORT: Scoping and Environmental Impact Assessment (EIA) Process for the Proposed Development of a Solar Photovoltaic (PV) Facility
(Kudu Solar Facility 7) and associated infrastructure, near De Aar, Northern Cape Province

Impact number	Receptor	Description	Stage	Character	Preventative and Mitigative Measures	Ease of Mitigation	Raw Risk						Residual Risk					
							(M+	E+	R+	D)x	P=	S	(M+	E+	R+	D)x	P=	S
Impact 6b:	Human and Equipment Safety - exposure to fire radiation	Causes - Power Conversion System (PCS – DC to AC) cooling failure, electrical fire. Consequences - Fire starts in PCS or another section or room and spreads to battery area.	Operation	Negative	Modern lithium container design places the PCS in another part of the container with a fire rated wall separating it from the battery. Alternately the PCS in another container altogether.	Moderate	5	2	5	5	4	68	5	2	5	5	1	17
							Significance						N4 - High					
Impact 7:	Human and Equipment Safety - exposure to explosion over pressures	Cause 1 - Transformer shorting / overheating / explosion. Cause 2 - Flammable gases generated by thermal run away reach explosive limits. Ignition on hot surfaces, static. Lithium Cobalt Oxide generates O2 during decomposition – escalation. Consequences - Potential fatalities amongst first responders. Damage to container or other nearby items, e.g., other container.	Operation	Negative	Electrical equipment will be specified to suit application. Emergency response plan and employee training referred to above is to be in place. This is only really likely to happen due to possible inappropriate emergency response, e.g., opening containers when they may be the type that should be left to burn out. Modern state of the art containers have ventilation systems for vapours. Undertake a hazardous area classification of the inside of the container to confirm the rating of electrical equipment, due to possible leaks of electrolyte or generation of flammable gases under thermal run away. Emergency response plan and employee training referred to above is critical. Suitable training of selected emergency responders who may be called out to the facilities is critical. NOTE. Refer to Appendix A for an initial approximation of worst-case possible explosion impact zones.	Moderate	5	1	5	5	2	32	5	1	5	5	1	16
							Significance						N3 - Moderate					

ENVIRONMENTAL IMPACT ASSESSMENT REPORT: Scoping and Environmental Impact Assessment (EIA) Process for the Proposed Development of a Solar Photovoltaic (PV) Facility
(Kudu Solar Facility 7) and associated infrastructure, near De Aar, Northern Cape Province

Impact number	Receptor	Description	Stage	Character	Preventative and Mitigative Measures	Ease of Mitigation	Raw Risk						Residual Risk					
							(M+)	E+	R+	D)x	P=	S	(M+)	E+	R+	D)x	P=	S
Impact 8a:	Human and Equipment Safety - exposure to acute toxic chemical and biological agents	Causes Human pathogens and diseases, sewage, food waste. Snakes, insects, wild and domesticated animals and harmful plants. Consequences - Illness and at worst without mitigation, possibly extending to fatalities. Effects can vary from discomfort to fatalities for venomous snakes or bee swarms etc	Operation	Negative	All necessary good hygiene practices to be in place, e.g., provision of sanitation facilities, eating areas, infectious disease controls. Policies and practice for dealing with known vectors of disease such as AIDS, TB, COVID 19 and others. Awareness training for persons on site, safety induction to include animal hazards. First aid and emergency response to consider the necessary anti-venom, anti-histamines, topical medicines etc. Due to isolated locations some distance from town, the ability to treat with anti-venom and extreme allergic reactions on site is critical to mitigate the impacts	Moderate	4	1	3	2	3	30	3	1	2	2	2	16
							Significance						N2 - Low			N2 - Low		
Impact 8b:	Human and Equipment Safety - exposure to acute toxic chemical and biological agents	Causes - Damaged batteries components, leak electrolyte, are completely broken exposing hazardous chemicals. Hazardous fumes released on thermal run away see fire above. Consequences - Impacts can vary from mild skin irritation from exposure to small leaks to serious corrosive burns for large exposure.	Operation	Negative	Acid resistant PPE (e.g., overalls, gloves, eyeglasses) to be specified for all operations in electrolyte areas. PPE to be increased (e.g., full-face shield, aprons, chemical suits) for operations that involve opening equipment and potential exposure, e.g., sampling, maintenance. All operators/maintenance staff trained in the hazards of chemicals on site. Batteries contained, modules contained and all inside a container that acts as bund. Refer to fire above as all the protective measures apply to prevent toxic smoke. Refer to fire above as all the measures apply to mitigate toxic smoke. 24/7 helpline response. Standard dangerous goods requirements for Hazmat labels. All operators/maintenance staff trained in the	Moderate	4	3	3	5	3	45	3	3	3	5	2	28

ENVIRONMENTAL IMPACT ASSESSMENT REPORT: Scoping and Environmental Impact Assessment (EIA) Process for the Proposed Development of a Solar Photovoltaic (PV) Facility
(Kudu Solar Facility 7) and associated infrastructure, near De Aar, Northern Cape Province

Impact number	Receptor	Description	Stage	Character	Preventative and Mitigative Measures	Ease of Mitigation	Raw Risk						Residual Risk							
							(M+	E+	R+	D)x	P=	S	(M+	E+	R+	D)x	P=	S		
		In the case of toxic fumes, serious lung damage.			hazards. NOTE Refer to Appendix A for an initial approximation of worst case possible noxious smoke impact zones.															
						Significance	N3 - Moderate						N2 - Low							
Impact 9:	Human and Equipment Safety - exposure to violent release of kinetic or potential energy	Causes - Moving equipment, pumps, heavy equipment at elevation, nip points, working at heights. Traffic accidents. Earthquake / tremor. Consequences - Injury. Fatality in unlikely worst case, e.g., traffic accidents or fall from heights. Damage to equipment, spills, environment pollution	Operation	Negative	Apart from pumps, no major moving parts during operation. Maintenance equipment to be serviced and personnel suitably trained in the use thereof. Normally just small vehicles on site, bakkies, grass cutting, cherry-pickers etc. Possibly large cranes if large equipment or elevated structure removed/replaced. Traffic signs, rules etc in place on site. All normal working at heights, hot work permits, confined space entry, cordon off unsafe areas/works etc to be in place. Emergency response plan. Civil design to take seismic activity into account.	Moderate	5	1	5	5	3	48	5	1	5	5	1	16		
							N3 - Moderate						N2 - Low							

ENVIRONMENTAL IMPACT ASSESSMENT REPORT: Scoping and Environmental Impact Assessment (EIA) Process for the Proposed Development of a Solar Photovoltaic (PV) Facility
(Kudu Solar Facility 7) and associated infrastructure, near De Aar, Northern Cape Province

Impact number	Receptor	Description	Stage	Character	Preventative and Mitigative Measures	Ease of Mitigation	Raw Risk						Residual Risk					
							(M+)	E+	R+	D)x	P=	S	(M+)	E+	R+	D)x	P=	S
Impact 10:	Human and Equipment Safety - exposure to electromagnetic waves	Causes - Use of electrical machines, generators etc. Hot dry area static generation is highly likely. Lightning strike. Consequences - Electrocution. Ignition and burns. Injury and death. Damage electrical equipment.	Operation	Negative	<p>Codes and guidelines for electrical insulation. Suitable PPE to be specified. Low voltage equipment (e.g., batteries) separated from high voltage equipment (e.g. transmission lines), minimum is 20m. Ensure trained personnel and refer to guideline – IEE 1657 – 2018. Ensure compliance with Eskom Operating Regulations for high voltage systems including access control, permit to work, safe work procedures, live work, abnormal and emergency situations, keeping records. Electromagnetic fields, impact on other equipment e.g., testing devices, mobile phones – malfunction, permanent damage. Software also need to be kept as update to date as reasonably practicable. Consider suitably located Emergency stop buttons for the facility and the other equipment on site. PPE to consider static accumulation for entering the facility, and particularly the battery containers especially after a high temperature shut down where there could possibly be flammable materials. The procedures for responding to alarm and auto shut down on containers, needs to consider that there may be a dangerous environment inside and how to protect personnel who may enter to respond.</p> <p>Lightning strike rate in proposed development area is moderate. All outside work must be stopped during thunder storms. Lighting conductors may be required for the installation, to be confirmed during design</p>	Complex	5	2	5	5	3	51	5	2	5	5	1	17
Impact 11:	Environment - emissions to air	Not expected on a normal basis. Refrigerant may be an asphyxiant if accidentally released	Operation	Negative	Especially after any warning alarms have gone off, but possibly even normally the container could be treated as entering a confined space and similar procedures could be in place, e.g., do not enter	Easy	3	1	1	1	3	18	3	1	1	1	1	6

ENVIRONMENTAL IMPACT ASSESSMENT REPORT: Scoping and Environmental Impact Assessment (EIA) Process for the Proposed Development of a Solar Photovoltaic (PV) Facility (Kudu Solar Facility 7) and associated infrastructure, near De Aar, Northern Cape Province

Impact number	Receptor	Description	Stage	Character	Preventative and Mitigative Measures	Ease of Mitigation	Raw Risk						Residual Risk							
							(M+	E+	R+	D)x	P=	S	(M+	E+	R+	D)x	P=	S		
		indoors it can accumulate and displace oxygen.			alone, gas testing prior to entering, ensure adequate ventilation.															
Significance							N2 - Low						N1 - Very Low							
Impact 12:	Environment - emissions to water	Causes - Cooling water blow-down. Laboratory waste (if included in the design). Maintenance waste, e.g., oils. Spills from batteries, coolant system, diesel trucks, transformers. Parked vehicles – oil drips. Fire water runoff control. Kitchen waste and sewage. Refrigerant release. Consequences - Pollution if not contained. Excessive disposal costs if emissions not limited.	Operation	Negative	Bunding under any outdoors tanks, curbing under truck offloading areas and sealed surfaces (e.g., concrete) under truck parking area is particularly important. Sewage and any kitchen liquids - containment and suitable treatment/disposal. Procedures for dealing with damaged/leaking equipment as well as clean-up of spills. Normal site practices for preventing and containing diesel/paint etc spills. Waste management plan to be in place e.g., liquid waste treatment or suitable removal and disposal will be provided. Spill clean-up procedures to be in place before bringing container on site, including spill kits – non-combustible materials, hazmat disposal. The National Environment Management Act (NEMA) Section 30, the DEA Guidelines have a list of hazard categories with Reportable spill Quantities, ensure compliance with this by listing all materials on site, their hazard categories and determining the spill thresholds for reporting.	Moderate	2	2	3	2	3	27	2	2	3	2	2	18		
Significance							N2 - Low						N2 - Low							
Impact 13:	Environment - emissions to earth	Causes - Mess area and other solid waste. Disposal of solid-state batteries. Consequences - Environmental damage.	Operation	Negative	Implement waste segregation (e.g., electronic equipment, chemicals, domestic) and management on the site.	Easy	2	2	3	3	3	30	2	2	3	3	1	10		

ENVIRONMENTAL IMPACT ASSESSMENT REPORT: Scoping and Environmental Impact Assessment (EIA) Process for the Proposed Development of a Solar Photovoltaic (PV) Facility
(Kudu Solar Facility 7) and associated infrastructure, near De Aar, Northern Cape Province

Impact number	Receptor	Description	Stage	Character	Preventative and Mitigative Measures	Ease of Mitigation	Raw Risk						Residual Risk											
							(M+	E+	R+	D)x	P=	S	(M+	E+	R+	D)x	P=	S						
							Significance						N2 - Low						N1 - Very Low					
Impact 14:	Environment - waste of resources e.g., water, power etc	Causes - Similar to construction phase. Disposal of batteries or components. Disposal of containers. Water usage not controlled. Consequences - Delays. Excessive costs and disposal of large volumes of hazardous waste.	Operation	Negative	Water usage to be monitored on site. Handling protocols to be provided by supplier of batteries. Water management plan and spill containment plans to be in place. Investigate end of Life plan for solid state batteries - reuse / recovery / reconditioning. Similarly, for decommissioned containers – reuse / recovery / repurpose	Easy	1	1	1	2	4	20	1	1	1	2	2	10						
							Significance						N2 - Low						N1 - Very Low					
Impact 15:	Public - Aesthetics	Causes - Bright surfaces reflecting light. Tall structures in a flat area. Consequences - Irritation.	Operation	Negative	Refer to the Visual Impact Assessment undertaken as part of the EIA.	Easy	1	2	4	4	2	22	1	2	4	4	2	22						
							Significance						N2 - Low						N2 - Low					
Impact 16:	Investors - Financial	Causes - Defective technology. Extreme project delays. Consequences - Financial loss	Operation	Negative	Operation by experienced personnel using internationally recognized and proven technology operating procedures. Operations management with deviation monitoring.	Easy	5	1	3	4	3	39	3	1	3	4	2	22						
							Significance						N3 - Moderate						N2 - Low					

ENVIRONMENTAL IMPACT ASSESSMENT REPORT: Scoping and Environmental Impact Assessment (EIA) Process for the Proposed Development of a Solar Photovoltaic (PV) Facility (Kudu Solar Facility 7) and associated infrastructure, near De Aar, Northern Cape Province

Impact number	Receptor	Description	Stage	Character	Preventative and Mitigative Measures	Ease of Mitigation	Raw Risk						Residual Risk					
							(M+	E+	R+	D)x	P=	S	(M+	E+	R+	D)x	P=	S
Impact 17a:	Employees and investors - Security	Causes - On route, potential hi-jacking of valuable but hazardous load. On site, theft of construction equipment and battery installation facilities. Civil unrest or violent strike by employees. Consequences - Theft. Injury to burglars. Damage to equipment possibly setting off thermal runaway.	Operation	Negative	Fencing around electrical infrastructure to SANS standard and Eskom Guidelines. Consider motion detection lights and CCTV. The hazardous nature of the electrical and battery equipment should be clearly indicated – e.g., Skull and Cross Bones or other signs. Isolated location both helps and hinders security. Night lighting to be provided both indoors and outdoors where necessary.	Moderate	3	1	3	2	4	36	3	1	3	2	2	18
							Significance						N3 - Moderate			N2 - Low		
Impact 17b:	Employees and investors - Security	Causes - Cyber security attacks aimed at the National Electricity Grid. Consequences - Ransom of the National Electricity Grid.	Operation	Negative	Cyber security needs monitoring. Remote access to system needs to be negotiated and controlled e.g. Password controls, levels of authority etc.to ensure protection of the National Electricity Grid from Cyber-attacks accessing through the BESS. Cyber emergency procedures – should be in place prior to commissioning.	Complex	4	4	3	1	4	48	4	4	3	1	2	24
							Significance						N3 - Moderate			N2 - Low		

ENVIRONMENTAL IMPACT ASSESSMENT REPORT: Scoping and Environmental Impact Assessment (EIA) Process for the Proposed Development of a Solar Photovoltaic (PV) Facility
(Kudu Solar Facility 7) and associated infrastructure, near De Aar, Northern Cape Province

Impact number	Receptor	Description	Stage	Character	Preventative and Mitigative Measures	Ease of Mitigation	Raw Risk						Residual Risk					
							(M+	E+	R+	D)x	P=	S	(M+	E+	R+	D)x	P=	S
Impact 18:	Emergencies	Causes - Fires, explosions, toxic smoke, large spills, traffic accidents, equipment/structural collapse. Inadequate emergency response to small event leads to escalation. Consequences - Injuries turn to fatalities, small losses become extended down time.	Operation	Negative	All safety measures listed above. Emergency procedures need to be practiced prior to commencement of operations. Escape doors should swing open outwards and not into the container. Doors should be able to be hooked open when persons are inside the container, i.e. they should not be automatically self-closing. More than one exit from buildings. Storage of spare batteries (e.g., in stores on site or elsewhere) also needs to consider possible thermal run away.	Complex	4	2	3	4	3	39	4	2	3	4	2	26
							Significance						N3 - Moderate			N2 - Low		
Impact 19:	Investors - Legal	Causes Battery field is evolving quickly with new guides, codes and regulations happening at the same time as evolving technology. Consequences - Unknown hazards manifest due to using "cheaper supplier or less developed technology".	Operation	Negative	Use only internationally reputable battery suppliers who comply with all known regulations/guideline at the time of purchasing. Where reasonably practicable ensure only "state of the art" battery systems are used and not old technologies prone to fires/explosions etc.	Moderate	3	1	3	3	4	40	3	1	3	3	2	20
							Significance						N3 - Moderate			N2 - Low		

The above Risk Assessment shows that, provided the preventative and mitigative measures are incorporated, the operational phase of the project does not present any high risks nor any fatal flaws. The average raw risk significance is rated as moderate, and the average residual risk is rated as low.

TABLE 15.4.1.3 - DECOMMISSIONING PHASE

Battery components may have a limited lifespan, there are damaged equipment etc. There could already be “waste” on the first day of commissioning and plans should be in place to deal with this. Ideally an End-of-Life plan needs to be in place before the first BESS container / equipment is brought on site.

All decommissioning activities must comply with the relevant regulations at the time. Decommissioning will ultimately need to be informed by the regulatory requirements at the time, which may be different to present requirements. The exact risk ratings are not possible to determine now given the uncertainties in mitigations applicable at that time. Except for the actual physical disposal to ground and its legal aspects the ratings for all other hazards have been left as neutral and the mitigation measures applied to the hazards during the construction and operational phases would also be applicable during de-commissioning.

Impact number	Receptor	Description	Stage	Character	Preventative and Mitigative Measures	Ease of Mitigation	Raw Risk						Residual Risk					
							(M+	E+	R+	D)x	P=	S	(M+	E+	R+	D)x	P=	S
Impact 1:	Human Health - chronic exposure to toxic chemical or biological agents	Similar to the construction and operational phases - no new hazards.	De-commission	Negative	As per construction and operational phases.	Easy												
							Significance						#N/A					
Impact 2:	Human Health - exposure to noise	Similar to the construction and operational phases - no new hazards.	De-commission	Negative	As per construction and operational phases.	Easy												
							Significance						#N/A					
Impact 3:	Human Health - exposure to temperature extremes and/or humidity	Similar to the construction and operational phases - no new hazards.	De-commission	Negative	As per construction and operational phases.	Easy												
							Significance						#N/A					
Impact 4:	Human Health - exposure to psychological stress	Similar to the construction and operational phases - no new hazards.	De-commission	Negative	As per construction and operational phases.	Easy												
							Significance						#N/A					

ENVIRONMENTAL IMPACT ASSESSMENT REPORT: Scoping and Environmental Impact Assessment (EIA) Process for the Proposed Development of a Solar Photovoltaic (PV) Facility
(Kudu Solar Facility 7) and associated infrastructure, near De Aar, Northern Cape Province

Impact number	Receptor	Description	Stage	Character	Preventative and Mitigative Measures	Ease of Mitigation	Raw Risk						Residual Risk					
							(M+	E+	R+	D)x	P=	S	(M+	E+	R+	D)x	P=	S
Impact 5:	Human Health - exposure to ergonomic stress	Similar to the construction and operational phases - no new hazards.	De-commission	Negative	As per construction and operational phases.	Easy												
							Significance						#N/A					
Impact 6:	Human and Equipment Safety - exposure to fire radiation	Similar to the construction and operational phases - no new hazards.	De-commission	Negative	As per construction and operational phases.	Easy												
							Significance						#N/A					
Impact 7:	Human and Equipment Safety - exposure to explosion over pressures	Similar to the construction and operational phases - no new hazards.	De-commission	Negative	As per construction and operational phases.	Easy												
							Significance						#N/A					
Impact 8:	Human and Equipment Safety - exposure to acute toxic chemical and biological agents	Similar to the construction and operational phases - no new hazards.	De-commission	Negative	As per construction and operational phases.	Easy												
							Significance						#N/A					
Impact 9:	Human and Equipment Safety - exposure to violent release of kinetic or potential energy	Similar to the construction and operational phases - no new hazards.	De-commission	Negative	As per construction and operational phases.	Easy												
							Significance						#N/A					

ENVIRONMENTAL IMPACT ASSESSMENT REPORT: Scoping and Environmental Impact Assessment (EIA) Process for the Proposed Development of a Solar Photovoltaic (PV) Facility
(Kudu Solar Facility 7) and associated infrastructure, near De Aar, Northern Cape Province

Impact number	Receptor	Description	Stage	Character	Preventative and Mitigative Measures	Ease of Mitigation	Raw Risk						Residual Risk					
							(M+	E+	R+	D)x	P=	S	(M+	E+	R+	D)x	P=	S
Impact 10:	Human and Equipment Safety - exposure to electromagnetic waves	Similar to the construction and operational phases - no new hazards.	De-commission	Negative	As per construction and operational phases.	Easy												
							Significance						#N/A					
Impact 11:	Environment - emissions to air	Similar to the construction and operational phases - no new hazards.	De-commission	Negative	As per construction and operational phases.	Easy												
							Significance						#N/A					
Impact 12:	Environment - emissions to water	Similar to the construction and operational phases - no new hazards.	De-commission	Negative	As per construction and operational phases.	Easy												
							Significance						#N/A					
Impact 13:	Environment - emissions to earth	Causes - Batteries / equipment reached end of life and may leak. Consequences - Environment damage from heavy metal ions.	De-commission	Negative	End of Life shutdown procedure including a Risk Assessment of the specific activities involved. Where possible re-purpose the solid-state batteries / containers and equipment with associated environmental impact considered. Disposal according to local regulations and other directives such as the European Batteries Directive, where relevant. End of life, which is affected by temperature and time, cycles etc, should be predefined and the monitoring should be in place to determine if it has been reached.	Complex	4	3	3	5	4	60	4	3	3	5	2	30
							Significance						N3 - Moderate					
Impact 14:	Environment - waste of resources e.g., water, power etc	Similar to the construction and operational phases - no new hazards.	De-commission	Negative	As per construction and operational phases.	Easy												
							Significance						#N/A					

ENVIRONMENTAL IMPACT ASSESSMENT REPORT: Scoping and Environmental Impact Assessment (EIA) Process for the Proposed Development of a Solar Photovoltaic (PV) Facility
(Kudu Solar Facility 7) and associated infrastructure, near De Aar, Northern Cape Province

Impact number	Receptor	Description	Stage	Character	Preventative and Mitigative Measures	Ease of Mitigation	(M+	E+	R+	D)x	P=	S	(M+	E+	R+	D)x	P=	S	
							Raw Risk						Residual Risk						
Impact 15:	Public - Aesthetics	Similar to the construction and operational phases - no new hazards.	De-commission	Negative	As per construction and operational phases.	Easy													
Significance						#N/A						#N/A							
Impact 16:	Investors - Financial	Similar to the construction n and operational phases - no new hazards.	De-commission	Negative	As per construction and operational phases.	Easy													
Significance						#N/A						#N/A							
Impact 17:	Employees and investors - Security	Similar to the construction and operational phases - no new hazards.	De-commission	Negative	As per construction and operational phases.	Easy													
Significance						#N/A						#N/A							
Impact 18:	Emergencies	Similar to the construction and operational phases - no new hazards.	De-commission	Negative	As per construction and operational phases.	Easy													
Significance						#N/A						#N/A							
Impact 19:	Investors - Legal	Disposal of hazardous "waste" is rife with difficulties and numerous regulations that need to be complied with.	De-commission	Negative	Applicants should seek the opinion from a waste consultant on how to correctly dispose of hazardous waste.	Complex	3	1	3	3	4	40	3	1	3	3	3	30	
Significance						N3 - Moderate						N2 - Low							

As noted above, it is not possible to provide exact ratings for most impacts predicted during the decommissioning phase based on various factors. However, from an emissions and leakage perspective, recommended mitigation measures and a preliminary significance rating has been provided, which have a raw risk rating as moderate and residual risk as low.

15.4.2 VANADIUM REDOX FLOW BATTERY ENERGY STORAGE SYSTEMS

TABLE 15.4.2.1 - CONSTRUCTION PHASE (Excluding commissioning i.e. filling the system with electrolyte, testing and initial powerup of the batteries)

Impact number	Receptor	Description	Stage	Character	Preventative and Mitigative Measures	Ease of Mitigation	Raw Risk						Residual Risk					
							(M+	E+	R+	D)x	P=	S	(M+	E+	R+	D)x	P=	S
Impact 1:	Human Health - chronic exposure to toxic chemical or biological agents	Causes - Construction materials such as cement, paints, solvents, welding fumes, truck fumes etc. Consequences - Employee / contractor illness.	Construction	Negative	The construction phase will be managed according to all the requirements of the Occupational Health and Safety Act 85 of 1993 specifically the Construction Regulations. SHEQ policy in place. A detailed construction Risk Assessment to be undertaken prior to work. SHE procedure in place. PPE to be specified. SHE appointees in place. Contractor's safety files in place and up to date. All necessary health controls/ practices to be in place, e.g., ventilation of welding and painting areas. SHE monitoring and reporting programs in place. Emergency response plan to be in place prior to beginning construction and to include aspects such as appointment of emergency controller, provision of first aid, first responder contact numbers.	Moderate	3	1	3	4	4	44	1	1	3	4	2	18
Impact 2:	Human Health - exposure to noise	Causes - Drilling, piling, generators, air compressors. Consequences - Adverse impact on hearing of workers. Possible nuisance factor in near-by areas.	Construction	Negative	OHS Act Noise Induced Hearing Loss Regulations. Health Risk Assessment to determine if equipment noise exceeds 85dB at workstation and 61dB at boundary of the site Employees to be provided with hearing protection if working near equipment that exceeds the noise limits.	Easy	3	1	5	5	4	56	2	1	5	5	2	26

ENVIRONMENTAL IMPACT ASSESSMENT REPORT: Scoping and Environmental Impact Assessment (EIA) Process for the Proposed Development of a Solar Photovoltaic (PV) Facility (Kudu Solar Facility 7) and associated infrastructure, near De Aar, Northern Cape Province

Impact number	Receptor	Description	Stage	Character	Preventative and Mitigative Measures	Ease of Mitigation	Raw Risk						Residual Risk					
							(M+	E+	R+	D)x	P=	S	(M+	E+	R+	D)x	P=	S
Impact 3:	Human Health - exposure to temperature extremes and/or humidity	Causes - Heat during the day. Cold in winter. Consequence - Heat stroke. Hypothermia.	Construction	Negative	Construction site facilities to comply with Occupational Health and Safety Act 85 of 1993, specifically the thermal, humidity, lighting and ventilation requirements of the Environmental Regulations for Workplaces. Adequate potable water for employees to be provided during all phases of the project. Bore hole, bowser and tank or small water treatment plant may be required to provide potable water for the employees during all phases of the project. Geohydrology Assessment has been conducted during the EIA Phase to assess the impact of the use of groundwater.	Easy	3	2	3	1	2	18	2	2	3	1	1	8
Impact 4:	Human Health - exposure to psychological stress	Causes - Large projects bring many contractor workers into a small, isolated community. Consequences – Lack of sufficient accommodation, entertainment etc. Increase in alcohol abuse, violence	Construction	Negative	Refer to the Socio-Economic Specialist Study undertaken as part of the EIA for this project.	Easy	2	3	3	2	2	20	2	3	3	2	2	20
Impact 5:	Human Health - exposure to ergonomic stress	Causes - Lifting heavy equipment. Awkward angles during construction. Consequences - Back and other injuries.	Construction	Negative	Training in lifting techniques. Ensure that despite the isolated location all the necessary equipment is available (and well maintained) during construction. Otherwise, employees may revert to unsafe practices. Ensure this is in place prior to project commencement Ensure first aid provision on site.	Moderate	4	1	3	2	3	30	4	1	3	2	2	20

ENVIRONMENTAL IMPACT ASSESSMENT REPORT: Scoping and Environmental Impact Assessment (EIA) Process for the Proposed Development of a Solar Photovoltaic (PV) Facility (Kudu Solar Facility 7) and associated infrastructure, near De Aar, Northern Cape Province

Impact number	Receptor	Description	Stage	Character	Preventative and Mitigative Measures	Ease of Mitigation	Raw Risk						Residual Risk					
							(M+)	E+	R+	D)x	P=	S	(M+)	E+	R+	D)x	P=	S
Impact 6:	Human and Equipment Safety - exposure to fire radiation	Causes – Involvement in an external fire. Fire involving fuels used in construction vehicles or vehicles themselves (e.g., tyre fire). Fire due to uncontrolled welding or other hot-work Consequences - Injuries due to radiation especially amongst first responders and bystanders. Fatalities unlikely from the heat radiation as not highly flammable nor massive fire.	Construction	Negative	Fuels stored on site in dedicated, demarcated and bunded areas. Suitable fire-fighting equipment on site near source of fuel, e.g., diesel tank, generators, mess, workshops etc. The company responsible for the facility at this stage is to have: 1. Emergency plan to be in place prior to commencement of construction. 2. Fuel spill containment procedures and equipment to be in place. 3. Hot-work permit and management system to be in place.	Complex	4	2	3	5	4	56	4	2	3	5	2	28
							Significance						N3 - Moderate					
Impact 7:	Human and Equipment Safety - exposure to explosion over pressures	No credible causes	Construction	Negative	None identified due to no credible causes.	N/A	1	1	1	1	1	4	1	1	1	1	1	4
						Significance						#N/A						

ENVIRONMENTAL IMPACT ASSESSMENT REPORT: Scoping and Environmental Impact Assessment (EIA) Process for the Proposed Development of a Solar Photovoltaic (PV) Facility (Kudu Solar Facility 7) and associated infrastructure, near De Aar, Northern Cape Province

Impact number	Receptor	Description	Stage	Character	Preventative and Mitigative Measures	Ease of Mitigation	Raw Risk							Residual Risk				
							(M+	E+	R+	D)x	P=	S	(M+	E+	R+	D)x	P=	S
Impact 8:	Human and Equipment Safety - exposure to acute toxic chemical and biological agents	Causes Human pathogens and diseases, sewage, food waste. Snakes, insects, wild and domesticated animals and harmful plants. Consequences - illness and at worst without mitigation, possibly extending to fatalities. Effects can vary from discomfort to fatalities for venomous snakes or bee swarms etc.	Construction	Negative	All necessary good hygiene practices to be in place, e.g., provision of sanitation facilities, eating areas, infectious disease controls. Policies and practice for dealing with known vectors of disease such as AIDS, TB, COVID 19 and others. Awareness training for persons on site, safety induction to include animal hazards. First aid and emergency response to consider the necessary anti-venom, anti-histamines, topical medicines etc. Due to isolated locations some distance from town, the ability to treat with anti-venom and extreme allergic reactions on site is critical to mitigate the impacts.	Complex	4	2	3	2	3	33	3	2	3	2	2	20

ENVIRONMENTAL IMPACT ASSESSMENT REPORT: Scoping and Environmental Impact Assessment (EIA) Process for the Proposed Development of a Solar Photovoltaic (PV) Facility (Kudu Solar Facility 7) and associated infrastructure, near De Aar, Northern Cape Province

Impact number	Receptor	Description	Stage	Character	Preventative and Mitigative Measures	Ease of Mitigation	Raw Risk						Residual Risk					
							(M+	E+	R+	D)x	P=	S	(M+	E+	R+	D)x	P=	S
Impact 9:	Human and Equipment Safety - exposure to violent release of kinetic or potential energy	Causes - Construction moving equipment, heavy loaded, elevated loads, working at heights Consequences - Injury or possibly fatality. Damage to equipment. Delays in starting the project, financial losses	Construction	Negative	<p>The construction phase will be managed according to all the requirements of the Occupational Health and Safety Act 85 of 1993 specifically the Construction Regulations. SHEQ policy in place.</p> <p>A detailed construction Risk Assessment to be undertaken prior to work. SHE procedure in place. PPE to be specified. SHE appointees in place.</p> <p>Contractors safety files in place and up to date. SHE monitoring and reporting programs in place. Standard construction site rules regarding traffic, reversing sirens, rigging controls, cordoning off excavations etc.</p> <p>Civil and building structures to comply with the National Building Regulations and building Standards Act 103 of 1977, SANS 10400 and other relevant codes.</p> <p>Other constructions such as roads, sewers etc also to comply with relevant SANS standards.</p> <p>All normal procedures for working at heights, hot work permits, confined space entry, cordon off excavations etc to be in place before construction begins.</p> <p>Emergency response plan to be in place before construction begins.</p>	Complex	5	1	5	5	4	64	5	1	5	5	1	16

ENVIRONMENTAL IMPACT ASSESSMENT REPORT: Scoping and Environmental Impact Assessment (EIA) Process for the Proposed Development of a Solar Photovoltaic (PV) Facility (Kudu Solar Facility 7) and associated infrastructure, near De Aar, Northern Cape Province

Impact number	Receptor	Description	Stage	Character	Preventative and Mitigative Measures	Ease of Mitigation	Raw Risk							Residual Risk				
							(M+	E+	R+	D)x	P=	S	(M+	E+	R+	D)x	P=	S
Impact 10:	Human and Equipment Safety - exposure to electromagnetic waves	Causes - Use of electrical machines, generators etc. Hot dry area static generation is highly likely. Lightning strike. Consequences - Electrocutation. Ignition and burns. Injury and death. Damage electrical equipment.	Construction	Negative	Standard maintenance of condition of electrical equipment and safe operating instructions. Ability to shut off power to systems in use on site. If persons are decanting fuels or dealing with other highly flammable materials care should be taken regarding possible static discharge, and installations to be suitably designed and maintained. Lightning strike rate in the study area is moderately low. Outside work must be stopped during thunderstorms. Lighting conductors may be required for the final installation, to be confirmed during design phase. Risk to and from electricity transmission pylons, suggest separation at least the pylon fall height, e.g. >10m for 10m tall pylons.	Complex	5	2	5	5	3	51	5	2	5	5	1	17
Impact 11:	Environment - emissions to air	Causes - Dust from construction and generally hot dry area. Consequences - Adverse impact on employee health.	Construction	Negative	May need to use dampening on roads etc. as per normal construction practices. May need PPE (dust masks) for specific construction workers.	Easy	3	2	1	1	4	28	2	2	1	1	2	12

ENVIRONMENTAL IMPACT ASSESSMENT REPORT: Scoping and Environmental Impact Assessment (EIA) Process for the Proposed Development of a Solar Photovoltaic (PV) Facility
(Kudu Solar Facility 7) and associated infrastructure, near De Aar, Northern Cape Province

Impact number	Receptor	Description	Stage	Character	Preventative and Mitigative Measures	Ease of Mitigation	Raw Risk							Residual Risk				
							(M+	E+	R+	D)x	P=	S	(M+	E+	R+	D)x	P=	S
Impact 12:	Environment - emissions to water	Causes - Diesel for equipment, paints and solvents. Transformer oil spills. Sewage and kitchen/mess area wastewater. Consequences - Environmental damage, particularly to the surface and underground water in the area.	Construction	Negative	Normal construction site practices for preventing and containing fuels/paint/oil etc spills. Bunding under any temporary tanks, curbing under truck offloading areas and sealed surfaces (e.g., concrete) under truck parking area is particularly important. Spill clean-up procedures to be in place before commencing construction. Sewage and any kitchen liquids - containment and suitable treatment/disposal	Moderate	2	2	3	2	3	27	2	2	3	2	2	18
							Significance							N2 - Low				
Impact 13:	Environment - emissions to earth	Causes - Mess area and other solid waste. Consequences - Environmental damage.	Construction	Negative	There will be packaging materials that will need to be disposed of after the entire system is connected and commissioned as well as after regular maintenance. There will need to be waste segregation (e.g., electronic equipment, chemicals) and management on the site.	Easy	2	2	3	3	3	30	1	2	3	3	2	18
							Significance							N2 - Low				
Impact 14:	Environment - waste of resources e.g., water, power etc	Causes - Water usage not controlled. Battery equipment damaged. Consequences - Delays.	Construction	Negative	Water usage to be monitored on site during construction. Handling protocols to be provided by battery supplier. Water management plan and spill containment plans to be in place.	Easy	1	1	1	2	4	20	1	1	1	2	2	10
							Significance							N2 - Low				
Impact 15:	Public - Aesthetics	Causes - Bright surfaces reflecting light. Tall structures in a flat area. Consequences - Irritation.	Construction	Negative	Refer to the visual impact assessment undertaken as part of the EIA.	Moderate	3	2	3	4	4	48	1	2	3	4	2	20
							Significance							N3 - Moderate				
														N2 - Low				

ENVIRONMENTAL IMPACT ASSESSMENT REPORT: Scoping and Environmental Impact Assessment (EIA) Process for the Proposed Development of a Solar Photovoltaic (PV) Facility (Kudu Solar Facility 7) and associated infrastructure, near De Aar, Northern Cape Province

Impact number	Receptor	Description	Stage	Character	Preventative and Mitigative Measures	Ease of Mitigation	Raw Risk						Residual Risk					
							(M+	E+	R+	D)x	P=	S	(M+	E+	R+	D)x	P=	S
Impact 16:	Investors - Financial	Causes - Defective technology. Extreme project delays. Consequences - Financial loss	Construction	Negative	Design by experienced contractors using internationally recognized and proven technology. Project management with deviation monitoring.	Moderate	5	1	3	4	3	39	3	1	3	4	2	22
						Significance	N3 - Moderate						N2 - Low					
Impact 17:	Employees and investors - Security	Causes - On route, potential hi-jacking of valuable but hazardous load. On site, theft of construction equipment and battery installation facilities. Civil unrest or violent strike by employees. Consequences - Theft. Injury to burglars. Damage to equipment possibly setting off thermal runaway.	Construction	Negative	Fencing around electrical infrastructure to SANS standard and Eskom Guidelines. The hazardous nature of the electrical and battery equipment should be clearly indicated – e.g., Skull and Cross Bones or other signs. Isolated location both helps and hinders security. Night lighting to be provided both indoors and outdoors where necessary.	Complex	4	1	3	2	4	40	3	1	3	2	3	27
						Significance	N3 - Moderate						N2 - Low					

ENVIRONMENTAL IMPACT ASSESSMENT REPORT: Scoping and Environmental Impact Assessment (EIA) Process for the Proposed Development of a Solar Photovoltaic (PV) Facility
(Kudu Solar Facility 7) and associated infrastructure, near De Aar, Northern Cape Province

Impact number	Receptor	Description	Stage	Character	Preventative and Mitigative Measures	Ease of Mitigation	Raw Risk						Residual Risk					
							(M+	E+	R+	D)x	P=	S	(M+	E+	R+	D)x	P=	S
Impact 18:	Emergencies	Causes - Fires, explosions, toxic smoke, large spills, traffic accidents, equipment/structural collapse. Inadequate emergency response to small event leads to escalation. Consequences - Injuries turn to fatalities, small losses become extended down time.	Construction	Negative	All safety measures listed above. Emergency procedures need to be practiced prior to commencement of construction.	Complex	4	2	3	4	3	39	4	2	3	4	2	26
							Significance						N3 - Moderate			N2 - Low		
Impact 19:	Investors - Legal	Causes Battery field is evolving quickly with new guides, codes and regulations happening at the same time as evolving technology. Consequences - Unknown hazards manifest due to using "cheaper supplier or less developed technology".	Construction	Negative	Use only internationally reputable battery suppliers who comply with all known regulations/guideline at the time of purchasing. Where reasonably practicable ensure only "state of the art" battery systems are used and not old technologies prone to fires/explosions etc.	Moderate	3	1	3	3	4	40	2	1	3	3	2	18
							Significance						N3 - Moderate			N2 - Low		

The above Risk Assessment shows that provided the preventative and mitigative measures are incorporated, the construction phase of the project does not present any high risks nor any fatal flaws. The average raw risk significance is rated as moderate, and the average residual risk is rated as low.

TABLE 15.4.2.2 - OPERATIONAL PHASE (Including Commissioning, e.g. filling the electrolyte into the tanks, testing the electrics, powering up the battery systems)

From the details of accidents that have happened both with BESS installations and chemical plants in general, it is clear that many potential problems manifest during the commissioning phase when units are first powered up to test functionality. This phase is critical and all controls, procedures, mitigation measures etc that would be in place for full operation should be in place before commissioning commences.

Impact number	Receptor	Description	Stage	Character	Preventative and Mitigative Measures	Ease of Mitigation	Raw Risk						Residual Risk					
							(M+	E+	R+	D)x	P=	S	(M+	E+	R+	D)x	P=	S
Impact 1a:	Human Health - chronic exposure to toxic chemical or biological agents	Causes - Operation and maintenance materials spare parts, paints, solvents, welding fumes, transformers oils, lubricating oils and greases etc. Consequences - Occupational illness.	Operation	Negative	<p>The operation and maintenance phase will be managed according to all the requirements of the Occupational Health and Safety Act 85 of 1993. SHEQ policy in place.</p> <p>A detailed Risk Assessment of all normal operating and maintenance activities on site to be compiled, and form the basis of operating instructions, prior to commencing commissioning.</p> <p>SHE procedure in place, e.g., PPE specified, management of change, integrity monitoring. SHE appointees in place.</p> <p>Training of staff in general hazards on site.</p> <p>All necessary health controls/ practices to be in place, e.g., ventilation of confined areas, occupational health monitoring if required and reporting programs in place.</p> <p>Emergency response plan for full operation and maintenance phase to be in place prior to beginning commissioning and to include aspects such as:</p> <ul style="list-style-type: none"> - appointment of emergency controller, - emergency isolation systems for electricity, - emergency isolation and containment systems for electrolyte, - provision of PPE for hazardous materials response, - provision of emergency facilities for staff at the main office building, - provision of first aid facilities, - first responder contact numbers etc. 	Easy	2	1	3	4	5	50	1	1	3	4	2	18
							Significance		N3 - Moderate						N2 - Low			

ENVIRONMENTAL IMPACT ASSESSMENT REPORT: Scoping and Environmental Impact Assessment (EIA) Process for the Proposed Development of a Solar Photovoltaic (PV) Facility
(Kudu Solar Facility 7) and associated infrastructure, near De Aar, Northern Cape Province

Impact number	Receptor	Description	Stage	Character	Preventative and Mitigative Measures	Ease of Mitigation	Raw Risk						Residual Risk					
							(M+)	E+	R+	D)x	P=	S	(M+)	E+	R+	D)x	P=	S
Impact 1b:	Human Health - chronic exposure to toxic chemical or biological agents	Causes - Compromised battery compartments vapours accumulate in the containers, solids/liquids on surfaces. Maintenance of battery components, corrosive and mildly toxic liquid on surfaces. Consequences - Dermatitis, skin /eye/lung irritation.	Operation	Negative	VRFB Batteries facilities normally within buildings but may be containerized. Maintenance procedures will be in place should equipment need to be opened, e.g., pumps drained and decontaminated prior to repair in workshop etc. PPE will be specified for handling battery parts and other equipment on site. Training of staff in hazards of chemicals on site. Labelling of all equipment. Confined space entry procedures if entering tanks. Safety Data Sheets (SDSs) to be available on site. Operating manuals to be provided including start-up, shut-down, steady state, monitoring requirements. Maintenance manuals with make safe, decontamination and repair procedures. Proposed maintenance schedules e.g., checklists for weekly, monthly, annual etc. Provided portable equipment for calibration and for testing/verification of defective equipment, e.g., volt/current meters, infrared camera	Complex	2	1	3	5	4	44	1	1	3	5	2	20
Impact 2:	Human Health - exposure to noise	Causes - Moving parts inside containers, buildings, pumps, compressors, cooling systems etc. Consequences - Adverse impact on hearing of workers. Nuisance factor at near -by residences or other activities.	Operation	Negative	Design to ensure continuous noise does not exceed 85dB within the facilities or at any other location on site or 61 dB at the site boundary, e.g., emergency generator, air compressor etc. Employees to be provided with hearing protection if working near equipment that exceeds the noise limits.	Easy	2	1	5	5	4	52	2	1	5	5	2	26

ENVIRONMENTAL IMPACT ASSESSMENT REPORT: Scoping and Environmental Impact Assessment (EIA) Process for the Proposed Development of a Solar Photovoltaic (PV) Facility
(Kudu Solar Facility 7) and associated infrastructure, near De Aar, Northern Cape Province

Impact number	Receptor	Description	Stage	Character	Preventative and Mitigative Measures	Ease of Mitigation	Raw Risk						Residual Risk					
							(M+	E+	R+	D)x	P=	S	(M+	E+	R+	D)x	P=	S
Impact 3:	Human Health - exposure to temperature extremes and/or humidity	Causes - Heat during the day. Batteries generate heat within enclosed building / containers. Cold in winter. Night work requires lighting. Consequences - Heat stroke. Hypothermia.	Operation	Negative	Building and container facilities to comply with Occupational Health and Safety Act 85 of 1993 specifically the thermal, humidity, lighting and ventilation requirements of the Environmental Regulations for Workplaces. Night work is likely for VRFB. Suitable lighting to be provided including emergency lighting for safe building exit in the event of power failure. Adequate potable water to be provided during all phases of the project. PPE for operations and maintenance staff to be suitable for the weather conditions.	Easy	4	2	3	1	2	20	3	2	3	1	1	9
							Significance						N2 - Low					
Impact 4:	Human Health - exposure to psychological stress	Causes - Isolated workstation and monotonous repetitive work. Consequences - Low performance, system productivity suffers.	Operation	Negative	Staff rotation to other activities within the site may be necessary. Performance monitoring of inspections / maintenance tasks in particular will be necessary.	Easy	2	3	3	2	2	20	1	3	3	2	1	9
							Significance						N2 - Low					
Impact 5:	Human Health - exposure to ergonomic stress	Causes - Lifting heavy equipment. Awkward angles during maintenance, stretching reaching to high level and bending to low level. Working to height if equipment located on top of electrolyte tanks, roofs or elevated electrical equipment (e.g., pylons). Consequences - Back and other injuries.	Operation	Negative	Training in lifting techniques. Training in working at heights. If equipment is at height (see OHS Act General Safety Regulation 6), ensure suitable safe (electrically and physically) ladders / harnesses etc. are available. Working at height procedure to be in place.	Easy	5	1	3	2	3	33	4	1	3	2	2	20
							Significance						N3 - Moderate					

ENVIRONMENTAL IMPACT ASSESSMENT REPORT: Scoping and Environmental Impact Assessment (EIA) Process for the Proposed Development of a Solar Photovoltaic (PV) Facility
(Kudu Solar Facility 7) and associated infrastructure, near De Aar, Northern Cape Province

Impact number	Receptor	Description	Stage	Character	Preventative and Mitigative Measures	Ease of Mitigation	Raw Risk						Residual Risk					
							(M+	E+	R+	D)x	P=	S	(M+	E+	R+	D)x	P=	S
Impact 6a:	Human and Equipment Safety - exposure to fire radiation	<p>Causes – Involvement in an external fire e.g., veld fire, maintenance vehicle fire, electrical systems fire. Manufacturing defects or damage to battery leading to shorting and heating. High humidity condensation of water or ingress of water or flooding leading to shorting. Dust accumulation on electrical parts leading to overheating. Excessive electrical loads - surges Operator abuse BMS failure or software failure. Incorrect extinguishing medium, escalate the fire. Consequences - Contaminated run off. Radiation burns. No affected bystanders. Damaged equipment. Fire spreads to other units or offsite if grass/vegetation not controlled.</p>	Operation	Negative	<p>Grass cutting and fire breaks around the BESS installations. No combustible materials to be stored in or near the batteries or electrical infrastructure, e.g., separation of site diesel tank and separation from substations. In this case the risk is from the substation to the BESS and not vice versa. Apply normal electrical separation distances of substation to other independent infrastructure Fire resistant barrier between the batteries and the PCS side if in the same container. Design codes from USA and standards of practice UL9540, NFPA 855 and DNV GL RP 43. Detailed Failure Mode and Effect Analysis FMEA/Hazop/Bowtie to done during design at the component level and system levels. Safety integrity level rating of equipment (failure probably) with suitable redundancy if required. Site Acceptance Testing as part of commissioning of each unit and the overall system. BMS should be checking individual cell voltage as well as stack, module, container, system voltages/current etc. BMS tripping the cell and possibly the stack/ building unit or module/rack/container, if variations in voltage. Diagnostics easily accessible. Diagnostics able to distinguish cell from stack or cell from module faults. As per SANS Standards, suitable ingress protection (IP) level provided for electrical equipment, e.g., IP55 - 66. If air cooling into container / building, suitable dust filters to be provided if needed. Smoke detectors may be needed linked to BMS and alerts in the main control room. Effects of battery aging to be considered. Temperature monitoring, regular infrared scanning. Data stored for trend analysis. Protective systems functionality testing. Prior to commencement of cold commissioning, emergency plan from transport and construction phase to extended to operational phase and to include the hazards of the electrically live system. Procedure to address suitable extinguishing media, ventilating, entering container as appropriate or not. PPE for firefighting may need to include fire retardant, chemically resistant, nitrile gloves, antistatic acid resistant boots, full face shields, BA sets. A planned fire response to prevent escalation to an environmental event is critical. Suitable fire extinguishing medium, cooling medium and adequate supply of both is critical e.g., cooling adjacent equipment and can use fogging nozzles to direct smoke. Ensure procedures in place to clean up after event Lingering toxic residues in the soil and on adjacent structures.</p>	Complex	5	1	5	5	3	48	5	1	5	5	1	16

ENVIRONMENTAL IMPACT ASSESSMENT REPORT: Scoping and Environmental Impact Assessment (EIA) Process for the Proposed Development of a Solar Photovoltaic (PV) Facility (Kudu Solar Facility 7) and associated infrastructure, near De Aar, Northern Cape Province

Impact number	Receptor	Description	Stage	Character	Preventative and Mitigative Measures	Ease of Mitigation	(M+	E+	R+	D)x	P=	S	(M+	E+	R+	D)x	P=	S
							Raw Risk						Residual Risk					
						Significance	N3 - Moderate						N2 - Low					
Impact 6b:	Human and Equipment Safety - exposure to fire radiation	Causes - Power Conversion System (PCS – DC to AC) cooling failure electrical fire. Consequences - Fire starts in PCS or another section or room and spreads to battery area.	Operation	Negative	VRFB building systems PCS in another area separating it from the batteries and other equipment	Moderate	5	2	5	5	3	51	5	2	5	5	1	17
						Significance	N3 - Moderate						N2 - Low					
Impact 7:	Human and Equipment Safety - exposure to explosion over pressures	Transformer shorting / overheating / explosion. Consequences - Potential fatalities, e.g., amongst first responders. Damage to nearby equipment.	Operation	Negative	Electrical equipment will be specified to suit application. Emergency response plan and employee training referred to above is to be in place.	Moderate	5	1	5	5	2	32	5	1	5	5	1	16
						Significance	N3 - Moderate						N2 - Low					

ENVIRONMENTAL IMPACT ASSESSMENT REPORT: Scoping and Environmental Impact Assessment (EIA) Process for the Proposed Development of a Solar Photovoltaic (PV) Facility (Kudu Solar Facility 7) and associated infrastructure, near De Aar, Northern Cape Province

Impact number	Receptor	Description	Stage	Character	Preventative and Mitigative Measures	Ease of Mitigation	Raw Risk						Residual Risk					
							(M+	E+	R+	D)x	P=	S	(M+	E+	R+	D)x	P=	S
Impact 8a:	Human and Equipment Safety - exposure to acute toxic chemical and biological agents	Causes Human pathogens and diseases, sewage, food waste. Snakes, insects, wild and domesticated animals and harmful plants. Consequences - Illness and at worst without mitigation, possibly extending to fatalities. Effects can vary from discomfort to fatalities for venomous snakes or bee swarms etc	Operation	Negative	All necessary good hygiene practices to be in place, e.g., provision of sanitation facilities, eating areas, infectious disease controls. Policies and practice for dealing with known vectors of disease such as AIDS, TB, COVID 19 and others. Awareness training for persons on site, safety induction to include animal hazards. First aid and emergency response to consider the necessary anti-venom, anti-histamines, topical medicines etc. Due to isolated locations some distance from town, the ability to treat with anti-venom and extreme allergic reactions on site is critical to mitigate the impacts	Moderate	4	1	3	2	3	30	3	1	2	2	2	16
							Significance						N2 - Low					
Impact 8b:	Human and Equipment Safety - exposure to acute toxic chemical and biological agents	Causes - Damaged batteries components, leak electrolyte, are completely broken exposing hazardous chemicals. Consequences - Impacts can vary from mild skin irritation from exposure to small leaks to serious corrosive burns for large exposure.	Operation	Negative	Corrosion resistant PPE (e.g., overalls, gloves, eyeglasses) to be specified for all operations in electrolyte areas. PPE to be increased (e.g., full-face shield, aprons, chemical suits) for operations that involve opening equipment and potential exposure, e.g., sampling, maintenance. All operators/maintenance staff trained in the hazards of chemicals on site. Electrolyte contained, modules contained inside a building that is banded. 24/7 helpline response. Standard dangerous goods requirements for Hazmat labels. All operators/maintenance staff trained in the hazards.	Moderate	4	3	3	5	3	45	3	3	3	5	2	28

ENVIRONMENTAL IMPACT ASSESSMENT REPORT: Scoping and Environmental Impact Assessment (EIA) Process for the Proposed Development of a Solar Photovoltaic (PV) Facility (Kudu Solar Facility 7) and associated infrastructure, near De Aar, Northern Cape Province

Impact number	Receptor	Description	Stage	Character	Preventative and Mitigative Measures	Ease of Mitigation	Raw Risk						Residual Risk					
							(M+	E+	R+	D)x	P=	S	(M+	E+	R+	D)x	P=	S
							Significance											
							N3 - Moderate						N2 - Low					
Impact 9:	Human and Equipment Safety - exposure to violent release of kinetic or potential energy	Causes - Moving equipment, pumps, heavy equipment at elevation, nip points, working at heights. Traffic accidents. Earthquake / tremor. Consequences - Injury. Fatality in unlikely worst case, e.g., traffic accidents or fall from heights. Damage to equipment, spills, environment pollution	Operation	Negative	Apart from pumps, no major moving parts during operation. Maintenance equipment to be serviced and personnel suitably trained in the use thereof. Normally just small vehicles on site, bakkies, grass cutting, cherry-pickers etc. Possibly large cranes if large equipment or elevated structure removed/replaced. Traffic signs, rules etc in place on site. All normal working at heights, hot work permits, confined space entry, cordon off unsafe areas/works etc to be in place. Emergency response plan. Civil design to take seismic activity into account.	Moderate	5	1	5	5	3	48	5	1	5	5	1	16
							N3 - Moderate						N2 - Low					

ENVIRONMENTAL IMPACT ASSESSMENT REPORT: Scoping and Environmental Impact Assessment (EIA) Process for the Proposed Development of a Solar Photovoltaic (PV) Facility (Kudu Solar Facility 7) and associated infrastructure, near De Aar, Northern Cape Province

Impact number	Receptor	Description	Stage	Character	Preventative and Mitigative Measures	Ease of Mitigation	Raw Risk						Residual Risk					
							(M+	E+	R+	D)x	P=	S	(M+	E+	R+	D)x	P=	S
Impact 10:	Human and Equipment Safety - exposure to electromagnetic waves	Causes - Use of electrical machines, generators etc. Hot dry area static generation is highly likely. Lightning strike. Consequences - Electrocutation. Ignition and burns. Injury and death. Damage electrical equipment.	Operation	Negative	<p>Codes and guidelines for electrical insulation. PPE to suit. Low voltage equipment (e.g., batteries) separated from high voltage (e.g., transmission to grid). Risk of pylons to BESS, suggest at least the pylon fall height, e.g. >10m for 10m tall pylons. Ensure trained personnel and refer to guideline – IEE 1657 – 2018. Ensure compliance with Eskom Operating Regulations for high voltage systems including access control, permit to work, safe work procedures, live work, abnormal and emergency situations, keeping records. Electromagnetic fields, impact on other equipment e.g., testing devices, mobile phones – malfunction, permanent damage. Software also need to be kept as update to date as reasonably practicable. Consider suitably located Emergency stop buttons for the facility and the other equipment on site. PPE to consider static accumulation for entering the facilities, and particularly the battery containers especially after a high temperature shut down where there could possibly be flammable materials. The procedures for responding to alarm and auto shut down on containers, needs to consider that there may be a dangerous environment inside and how to protect personnel who may enter to respond.</p> <p>Lightning strike rate in proposed development area is moderate. All outside work must be stopped during thunder storms. Lighting conductors may be required for the installation, to be confirmed during design</p>	Complex	5	2	5	5	3	51	5	2	5	5	1	17
Impact 11:	Environment - emissions to air	Not expected on a normal basis. Refrigerant may be an asphyxiant if	Operation	Negative	Especially after any warning alarms have gone off, but possibly even normally the container could be treated as entering a confined space and similar procedures could be in place, e.g., do not enter	Easy	3	1	1	1	3	18	3	1	1	1	1	6

ENVIRONMENTAL IMPACT ASSESSMENT REPORT: Scoping and Environmental Impact Assessment (EIA) Process for the Proposed Development of a Solar Photovoltaic (PV) Facility
(Kudu Solar Facility 7) and associated infrastructure, near De Aar, Northern Cape Province

Impact number	Receptor	Description	Stage	Character	Preventative and Mitigative Measures	Ease of Mitigation	Raw Risk						Residual Risk							
							(M+	E+	R+	D)x	P=	S	(M+	E+	R+	D)x	P=	S		
		accidentally released indoors it can accumulate and displace oxygen.			alone, gas testing prior to entering, ensure adequate ventilation															
						Significance	N2 - Low						N1 - Very Low							
Impact 12:	Environment - emissions to water	Causes - Cooling water blow-down. Laboratory waste (if included in the design). Maintenance waste, e.g., oils. Spills from batteries, coolant system, diesel trucks, transformers. Parked vehicles – oil drips. Fire water runoff control. Kitchen waste and sewage. Refrigerant release. VRFB electrolyte purging. Consequences - Pollution if not contained. Excessive disposal costs if emissions not limited.	Operation	Negative	Electrolyte areas fully bunded to 110% of largest tank, or more. Bunding under any outdoors tanks, curbing under truck offloading areas and sealed surfaces (e.g., concrete) under truck parking area is particularly important. Sewage and any kitchen liquids - containment and suitable treatment/disposal. Procedures for dealing with damaged/leaking equipment as well as clean-up of spills. Normal site practices for preventing and containing diesel/paint etc spills. Waste management plan to be in place e.g., liquid waste treatment or suitable removal and disposal will be provided. Spill clean-up procedures to be in place before bringing container on site, including spill kits – non-combustible materials, hazmat disposal. The National Environment Management Act (NEMA) Section 30, the DEA Guidelines have a list of hazard categories with Reportable spill Quantities, ensure compliance with this by listing all materials on site, their hazard categories and determining the spill thresholds for reporting. This is particularly relevant for liquid filled systems such as RFB. Process controls in place to prevent contamination and deterioration of electrolyte leading to excessive purging. Ensure proposed locations of the BESS facilities are a suitable distance from the closest water course. Relevant recommendations have been made by the Aquatic Specialist and Groundwater Specialists, and this has been factored into the layout. Refer to the	Moderate	3	2	3	2	3	30	3	2	3	2	2	2	20	

ENVIRONMENTAL IMPACT ASSESSMENT REPORT: Scoping and Environmental Impact Assessment (EIA) Process for the Proposed Development of a Solar Photovoltaic (PV) Facility (Kudu Solar Facility 7) and associated infrastructure, near De Aar, Northern Cape Province

Impact number	Receptor	Description	Stage	Character	Preventative and Mitigative Measures	Ease of Mitigation	Raw Risk						Residual Risk							
							(M+	E+	R+	D)x	P=	S	(M+	E+	R+	D)x	P=	S		
					relevant studies for additional information. In the event of a major spill if this is too close it may not allow time for mitigation to be taken. Adequate secondary and possibly tertiary containment systems may then be needed on site.															
Significance							N2 - Low						N2 - Low							
Impact 13:	Environment - emissions to earth	Causes - Mess area and other solid waste. Disposal of battery components. Consequences - Environmental damage.	Operation	Negative	Implement waste segregation (e.g., electronic equipment, chemicals, domestic) and management on the site. During commissioning there will be a need for bulk transport of electrolyte to site and transfer of electrolyte into the tanks within the containers. Suitable secondary containment of possible spills / overfills etc. during this transfer process will need to be in place.	Easy	2	2	3	3	4	40	2	2	3	3	2	20		
Significance							N3 - Moderate						N2 - Low							
Impact 14:	Environment - waste of resources e.g., water, power etc	Causes - Similar to construction phase. Disposal of batteries or components. Disposal of containers. Water usage not controlled. Excessive purging of	Operation	Negative	Water usage to be monitored on site. Handling protocols to be provided by supplier of electrolyte. Water management plan and spill containment plans to be in place. Investigate End of Life plan for electrolyte - reuse / recovery / reconditioning.	Easy	2	1	1	2	4	24	2	1	1	2	2	12		

ENVIRONMENTAL IMPACT ASSESSMENT REPORT: Scoping and Environmental Impact Assessment (EIA) Process for the Proposed Development of a Solar Photovoltaic (PV) Facility (Kudu Solar Facility 7) and associated infrastructure, near De Aar, Northern Cape Province

Impact number	Receptor	Description	Stage	Character	Preventative and Mitigative Measures	Ease of Mitigation	Raw Risk						Residual Risk							
							(M+	E+	R+	D)x	P=	S	(M+	E+	R+	D)x	P=	S		
		deteriorated or contaminated electrolyte. Consequences - Delays. Excessive costs and disposal of large volumes of hazardous waste.			Similarly, for decommissioned containers / equipment – reuse / recovery / repurpose															
							N2 - Low						N1 - Very Low							
Impact 15:	Public - Aesthetics	Causes - Bright surfaces reflecting light. Tall structures in a flat area. Consequences - Irritation.	Construction	Negative	Refer to the Visual Impact Assessment undertaken as part of the EIA.	Moderate	3	2	3	4	4	48	1	2	3	4	2	20		
Significance							N3 - Moderate						N2 - Low							
Impact 16:	Investors - Financial	Causes - Defective technology. Extreme project delays. Consequences - Financial loss	Operation	Negative	Operation by experienced personnel using internationally recognized and proven technology operating procedures. Operations management with deviation monitoring	Easy	5	1	3	4	3	39	3	1	3	4	2	22		
Significance							N3 - Moderate						N2 - Low							
Impact 17a:	Employees and investors - Security	Causes - On route, potential hi-jacking of valuable but hazardous load. On site, theft of construction equipment and battery installation facilities. Civil unrest or violent strike by employees. Consequences -	Operation	Negative	Fencing around electrical infrastructure to SANS standard and Eskom Guidelines. Consider motion detection lights and CCTV. The hazardous nature of the electrical and battery equipment should be clearly indicated – e.g., Skull and Cross Bones or other signs. Isolated location both helps and hinders security. Night lighting to be provided both indoors and outdoors where necessary.	Moderate	3	1	3	2	4	36	3	1	3	2	2	18		

ENVIRONMENTAL IMPACT ASSESSMENT REPORT: Scoping and Environmental Impact Assessment (EIA) Process for the Proposed Development of a Solar Photovoltaic (PV) Facility (Kudu Solar Facility 7) and associated infrastructure, near De Aar, Northern Cape Province

Impact number	Receptor	Description	Stage	Character	Preventative and Mitigative Measures	Ease of Mitigation	Raw Risk						Residual Risk							
							(M+	E+	R+	D)x	P=	S	(M+	E+	R+	D)x	P=	S		
		Theft. Injury to burglars. Damage to equipment possibly setting off thermal runaway.																		
Significance							N3 - Moderate						N2 - Low							
Impact 17b:	Employees and investors - Security	Causes - Cyber security attacks aimed at the National Electricity Grid. Consequences - Ransom of the National Electricity Grid.	Operation	Negative	Cyber security needs monitoring. Remote access to system needs to be negotiated and controlled e.g. password controls, levels of authority etc.to ensure protection of the National Electricity Grid from Cyber-attacks accessing through the BESS. Cyber emergency procedures – should be in place prior to commissioning	Complex	4	4	3	1	4	48	4	4	3	1	2	24		
Significance							N3 - Moderate						N2 - Low							
Impact 18:	Emergencies	Causes - Fires, explosions, toxic smoke, large spills, traffic accidents, equipment/structural collapse. Inadequate emergency response to small event leads to escalation. Consequences - Injuries turn to fatalities, small losses become extended down time.	Operation	Negative	All safety measures listed above. Emergency procedures need to be practiced prior to commencement of operations. Escape doors should swing open outwards and not into the building/container. More than one exit from buildings.	Complex	4	2	3	4	3	39	4	2	3	4	2	26		
Significance							N3 - Moderate						N2 - Low							

Impact number	Receptor	Description	Stage	Character	Preventative and Mitigative Measures	Ease of Mitigation	Raw Risk						Residual Risk					
							(M+	E+	R+	D)x	P=	S	(M+	E+	R+	D)x	P=	S
Impact 19:	Investors - Legal	Causes Battery field is evolving quickly with new guides, codes and regulations happening at the same time as evolving technology. Consequences - Unknown hazards manifest due to using "cheaper supplier or less developed technology".	Operation	Negative	Use only internationally reputable battery suppliers who comply with all known regulations/guideline at the time of purchasing. Where reasonably practicable ensure only "state of the art" battery systems are used and not old technologies prone to fires/explosions etc.	Moderate	3	1	3	3	4	40	3	1	3	3	2	20
							Significance						N3 - Moderate			N2 - Low		

The above Risk Assessment shows that, provided the preventative and mitigative measures are incorporated, the operational phase of the project does not present any high risks nor any fatal flaws. The average raw risk significance is rated as moderate, and the average residual risk is rated as low.

TABLE 15.4.2.3 - DECOMMISSIONING PHASE

Battery components may have a limited lifespan, there are damaged equipment, waste electrolyte etc. There could already be "waste" on the first day of commissioning and plans should be in place to deal with this. Ideally an End-of-Life plan needs to be in place before the first electrolyte / container / equipment is brought on site.

All decommissioning activities must comply with the relevant regulations at the time. Decommissioning will ultimately need to be informed by the regulatory requirements at the time, which may be different to present requirements. The exact risk ratings are not possible to determine now given the uncertainties in mitigations applicable at that time. Except for the actual physical disposal to ground and its legal aspects the ratings for all other hazards have been left as neutral and the mitigation measures applied to the hazards during the construction and operational phases would also be applicable during de-commissioning.

ENVIRONMENTAL IMPACT ASSESSMENT REPORT: Scoping and Environmental Impact Assessment (EIA) Process for the Proposed Development of a Solar Photovoltaic (PV) Facility
(Kudu Solar Facility 7) and associated infrastructure, near De Aar, Northern Cape Province

Impact number	Receptor	Description	Stage	Character	Preventative and Mitigative Measures	Ease of Mitigation	Raw Risk						Residual Risk					
							(M+	E+	R+	D)x	P=	S	(M+	E+	R+	D)x	P=	S
Impact 1:	Human Health - chronic exposure to toxic chemical or biological agents	Similar to the construction and operational phases - no new hazards.	De-commission	Negative	As per construction and operational phases.	Easy												
							Significance						#N/A					
Impact 2:	Human Health - exposure to noise	Similar to the construction and operational phases - no new hazards.	De-commission	Negative	As per construction and operational phases.	Easy												
							Significance						#N/A					
Impact 3:	Human Health - exposure to temperature extremes and/or humidity	Similar to the construction and operational phases - no new hazards.	De-commission	Negative	As per construction and operational phases.	Easy												
							Significance						#N/A					
Impact 4:	Human Health - exposure to psychological stress	Similar to the construction and operational phases - no new hazards.	De-commission	Negative	As per construction and operational phases.	Easy												
							Significance						#N/A					
Impact 5:	Human Health - exposure to ergonomic stress	Similar to the construction and operational phases - no new hazards.	De-commission	Negative	As per construction and operational phases.	Easy												
							Significance						#N/A					
Impact 6:	Human and Equipment Safety - exposure to fire radiation	Similar to the construction and operational phases - no new hazards.	De-commission	Negative	As per construction and operational phases.	Easy												
							Significance						#N/A					

ENVIRONMENTAL IMPACT ASSESSMENT REPORT: Scoping and Environmental Impact Assessment (EIA) Process for the Proposed Development of a Solar Photovoltaic (PV) Facility
(Kudu Solar Facility 7) and associated infrastructure, near De Aar, Northern Cape Province

Impact number	Receptor	Description	Stage	Character	Preventative and Mitigative Measures	Ease of Mitigation	Raw Risk						Residual Risk					
							(M+	E+	R+	D)x	P=	S	(M+	E+	R+	D)x	P=	S
Impact 7:	Human and Equipment Safety - exposure to explosion over pressures	Similar to the construction and operational phases - no new hazards.	De-commission	Negative	As per construction and operational phases.	Easy												
							Significance						#N/A					
Impact 8:	Human and Equipment Safety - exposure to acute toxic chemical and biological agents	Similar to the Construction and operational phases - no new hazards.	De-commission	Negative	As per construction and operational phases.	Easy												
							Significance						#N/A					
Impact 9:	Human and Equipment Safety - exposure to violent release of kinetic or potential energy	Similar to the Construction and operational phases - no new hazards.	De-commission	Negative	As per construction and operational phases.	Easy												
							Significance						#N/A					
Impact 10:	Human and Equipment Safety - exposure to electromagnetic waves	Similar to the Construction and operational phases - no new hazards.	De-commission	Negative	As per construction and operational phases.	Easy												
							Significance						#N/A					
Impact 11:	Environment - emissions to air	Similar to the Construction and operational phases - no new hazards.	De-commission	Negative	As per construction and operational phases.	Easy												
							Significance						#N/A					

ENVIRONMENTAL IMPACT ASSESSMENT REPORT: Scoping and Environmental Impact Assessment (EIA) Process for the Proposed Development of a Solar Photovoltaic (PV) Facility
(Kudu Solar Facility 7) and associated infrastructure, near De Aar, Northern Cape Province

Impact number	Receptor	Description	Stage	Character	Preventative and Mitigative Measures	Ease of Mitigation	Raw Risk						Residual Risk					
							(M+	E+	R+	D)x	P=	S	(M+	E+	R+	D)x	P=	S
Impact 12:	Environment - emissions to water	Similar to the Construction and operational phases - no new hazards.	De-commission	Negative	As per construction and operational phases.	Easy												
						Significance	#N/A						#N/A					
Impact 13:	Environment - emissions to earth	Causes - Batteries / electrolyte / equipment reached end of life and may leak. Consequences - Environment damage from heavy metal ions.	Construction	Negative	End of Life shutdown procedure including a Risk Assessment of the specific activities involved. Where possible re-purpose the solid-state batteries / containers and equipment with associated Environmental impact considered. Disposal according to local regulations and other directives such as the European Batteries Directive. End of life, which is affected by temperature and time, cycles etc, should be predefined and the monitoring should be in place to determine if it has been reached.	Complex	4	3	3	5	4	60	4	3	3	5	2	30
						Significance	N3 - Moderate						N2 - Low					
Impact 14:	Environment - waste of resources e.g., water, power etc	Similar to the Construction and operational phases - no new hazards.	De-commission	Negative	As per construction and operational phases.	Easy												
						Significance	#N/A						#N/A					
Impact 15:	Public - Aesthetics	Similar to the Construction and operational phases - no new hazards.	De-commission	Negative	As per construction and operational phases.	Easy												
						Significance	#N/A						#N/A					
Impact 16:	Investors - Financial	Similar to the Construction and operational phases - no new hazards.	De-commission	Negative	As per construction and operational phases.	Easy												
						Significance	#N/A						#N/A					
Impact 17:	Employees and investors - Security	Similar to the Construction and operational phases - no new hazards.	De-commission	Negative	As per construction and operational phases.	Easy												

ENVIRONMENTAL IMPACT ASSESSMENT REPORT: Scoping and Environmental Impact Assessment (EIA) Process for the Proposed Development of a Solar Photovoltaic (PV) Facility (Kudu Solar Facility 7) and associated infrastructure, near De Aar, Northern Cape Province

Impact number	Receptor	Description	Stage	Character	Preventative and Mitigative Measures	Ease of Mitigation	(M+	E+	R+	D)x	P=	S	(M+	E+	R+	D)x	P=	S
							Raw Risk						Residual Risk					
Significance							#N/A						#N/A					
Impact 18:	Emergencies	Similar to the Construction and operational phases - no new hazards.	De-commission	Negative	As per construction and operational phases.	Easy												
Significance							#N/A						#N/A					
Impact 19:	Investors - Legal	Disposal of hazardous "waste" is rife with difficulties and numerous regulations that need to be complied with.	De-commission	Negative	Applicants should seek the opinion from a waste consultant on how to correctly dispose of hazardous waste.	Complex	3	1	3	3	4	40	3	1	3	3	3	30
Significance							N3 - Moderate						N2 - Low					

The above Risk Assessment shows that, provided the preventative and mitigative measures are incorporated, the de-commissioning phase of the project does not present any high risks nor any fatal flaws.

15.5. CONCLUSIONS AND RECOMMENDATIONS

The tables in Section 15.4 contain all the recommended preventative and mitigative measures necessary to ensure risks are not unacceptably high.

Below are a few extracted items that are possibly of highest risks and therefore a priority.

15.5.1 CONCLUSIONS

GENERAL

- This Risk Assessment has found that with suitable preventative and mitigative measures in place, none of the identified potential risks are excessively high, i.e., from a SHE perspective no fatal flaws were found with either type of technology for the proposed BESS installation at the proposed Kudu Solar Facility near De Aar.
- At a large facility, without installation of the “state-of-the-art” battery technology that includes protective features, there can be significant risks to employees and first responders. The latest battery designs include many preventative and mitigative measures to reduce these risks to tolerable levels. (Refer to tables in section 15.4 under preventative and mitigative measures). Where reasonably practicable, state-of-the-art technology should be used, i.e., not old technology that may have been prone to fire and explosion risks.
- The design should be subject to a full Hazard and Operability Study (HAZOP) prior to commencement of procurement. A HAZOP is a detailed technical systematic study that looks at the intricacies of the design, the control system, the emergency system etc. and how these may fail under abnormal operating conditions. Additional safeguards may be suggested by the team doing the study.

LITHIUM SOLID STATE CONTAINERIZED BATTERIES

- With lithium solid-state batteries, the most significant hazard with battery units is the possibility of thermal runaway and the generation of toxic and flammable gases. There have been numerous such incidents around the world with batteries at all scales and modern technology providers include many preventative and mitigative features in their designs. This type of event also generates heat which may possibly propagate the thermal runaway event to neighbouring batteries if suitable “state of the art” technology is not employed.
- The flammable gases generated may ignite leading to a fire which accelerates the runaway process and may spread the fire to other parts of the BESS or other equipment located near-by.
- If the flammable gases accumulate within the container before they ignite, they may eventually ignite with explosive force. This type of event is unusual but has happened with an older technology container installed at McMicken in the USA in 2019.
- Due to a variety of causes, thermal runaway could happen at any point during transport of the BESS to the facility, during construction or operation / maintenance at the facility or during decommissioning and safe making for disposal.

- Due to the containerized approach as well as the usual good practice of separation between containers, which should be applied on this project, and therefore the likely restriction of events to one container at a time, the main risks are close to the containers i.e., to transport drivers, employees at the facilities and first responders to incidents.
- In terms of a worst conceivable case container fires, the significant impact zone is likely to be limited to within 10m of the container and mild impacts to 20m. Based on the current proposed layouts, impacts at the closest isolated farmhouses are not expected.
- In terms of a worst conceivable case explosion, the significant impact zone is likely to be limited to within 10m of the container and minor impacts such as debris within 50m. Based on the current proposed layouts, impacts at the closest isolated farmhouses are not expected.
- In terms of a worst reasonably conceivable toxic smoke scenario, provided the units are placed suitably far apart to prevent propagation from one unit to another and large external fires are prevented, the amount of material burning should be limited to one container at any one time. In this case, beyond the immediate vicinity of the fire, the concentrations of harmful gases within the smoke should be low. The proposed BESS installation's location should ideally be over 500m from any occupied development / farmhouse. The BESS is well over 500m from the closest facility to the east, and therefore the risks posed by BESS are acceptably low.
- Based on the above it is suggested that if the substation were over 20m from the closest BESS container there should be limited direct impacts of any fire or explosion on the substation. Fires at the substation are also not likely to lead to domino failures of the BESS.

VANADIUM REDOX FLOW BATTERY INSTALLATIONS

- The most significant hazard with VRFB units is the possibility of spills of corrosive and environmentally toxic electrolyte. Many preventative and mitigative features should be included in the design and operation, e.g., full secondary containment, level control on tanks, leak detection on equipment etc. (Refer to tables in section 15.4 under preventative and mitigative measures).
- VRFB units do not present significant fire and electrical arcing hazards provided they are correctly designed, operated, maintained and managed. Suitable Battery Management System (BMS), safety procedures, operating instructions, maintenance procedures, trips, alarms and interlocks should be in place. (Refer to tables in section 15.4 under preventative and mitigative measures).

TECHNOLOGY AND LOCATION OF BESS FACILITIES

- From a safety and health point of view, the above Risk Assessment shows that risks posed by VRFB systems may be slightly lower than those of SSL facilities, particularly with respect to fire and explosion risks. From an environmental spill and pollution point of view the VRFB systems present higher short-term risks than the SSL systems. However, the above conclusions may be due to the fact that the VRFB technology is not as mature as SSL technology and therefore there is not as much operating experience and accident information available for the VRFB. From an overall SHE RA point of view, there is no specific preference for a type of technology.

- From a SHE risk assessment point of view, where there is a choice of location that is further from public roads, water courses or isolated farmhouses/occupied developments, this would be preferred. VRFB hazards are mostly related to possible loss of containment of electrolyte and SSL batteries to fires producing toxic smoke and fire fighting which may result in contaminated firewater runoff. One would not want these liquids to enter water courses nor the smoke to pass close to houses / public traffic. The current chosen location meets these separation requirements, and the relevant specialists such as aquatic and geohydrology have provided inputs on setback distances.
- Changes to the detailed layouts post Environmental Authorisation (should such be granted) are deemed acceptable if the changes remain within the approved buildable areas / development footprints, and area assessed during this Scoping and EIA Process (with the avoidance of no-go sensitive areas) and any solid state (e.g. lithium) BESS is located over 500m from farm buildings.

15.5.2 RECOMMENDATIONS

The following recommendations have been made:

- There are numerous different battery technologies but using one consistent battery technology system for the BESS installations associated with all the Kudu developments in the De Aar area would allow for ease of training, maintenance, emergency response and could significantly reduce risks.
- Where reasonably practicable, state-of-the-art battery technology should be used with all the necessary protective features e.g., draining of cells during shutdown and standby-mode, full BMS with deviation monitoring and trips, leak detection systems.
- There are no fatal flaws associated with the proposed Kudu Solar Facility battery installation for either technology type.
- The tables in Section 4 of this report contains technical and systems suggestions for managing and reducing risks. Ensure the items listed in these tables under preventative and mitigative measures are included in the design.
- The overall design should be subject to a full HAZOP prior to finalization of the design.
- For the VRFB systems an end of life (and for possible periodic purging requirements) solution for the large quantities of hazardous electrolyte should be investigated, e.g., can it be returned to the supplier for re-conditioning.
- Prior to bringing any solid-state battery containers into the country, the contractor should ensure that:
 - An Emergency Response Plan is in place that would be applicable for the full route from the ship to the site. This plan would include details of the most appropriate emergency response to fires both while the units are in transit and once they are installed and operating.
 - An End-of-Life plan is in place for the handling, repurposing or disposal of dysfunctional, severely damaged batteries, modules and containers.
- The site layout and spacing between lithium solid-state containers should be such that it mitigates the risk of a fire or explosion event spreading from one container to another.
- Under certain weather conditions, the noxious smoke from a fire in a lithium battery container could

travel some distance from the unit. The smoke will most likely be acrid and could cause irritation, coughing, distress etc. Close to the source of the smoke, the concentration of toxic gases may be high enough to cause irreversible harmful effects. Location of the facilities needs to ensure a suitable separation distance from public facilities/residences etc. The proposed BESS location is well over 500m from isolated farmhouses/development and is therefore suitable in this context.

- In order to limit the possibility of domino failures the BESS should be separated from the substation by at least 20m.
- Where there is a choice of alternative locations for the BESS, those that are further from water courses would be preferred. VRFB hazards are mostly related to possible loss of containment of electrolyte and solid-state systems may experience fires that may result in loss of containment of liquids or the use of large amounts of fire water which could be contaminated. One would not want these run-offs to enter water courses directly. The buffer distance between water bodies and the facilities containing chemicals should be set in consultation with a water specialist and is therefore not specified in this SHE RA. It is noted that there are no tributaries of the main water courses in the area within 500m of the proposed BESS location, and therefore this is not a risk of concern.
- Finally, it is suggested once the BESS technology has been chosen and more details of the final design are available, the necessary updated Risk Assessments should be in place (prior to commencement, after environmental authorisation and other necessary approvals are granted (should such be granted)).

15.6 REFERENCES

1. "National Environmental Management Act, 1998 (Act No. 107 of 1998), as amended (NEMA) and the NEMA EIA Regulations, 2014, as amended. Government Gazette No 19519 of 27 November 1998.
2. "Environmental Impact Assessment Regulations, 2014, as amended", Government Gazette No 326 of 7 April 2017.
3. SABS, "SANS 10228 – The Identification and Classification of Dangerous Goods for Transport", Standards South Africa, Pretoria, 2012.
4. SABS, "SANS 10234 – Globally Harmonize System of classification and labelling of chemicals (GHS)", SABS, Pretoria 2008.
5. SABS, "Supplement to SANS 10234 – List of classification and labelling of chemicals in accordance with the Globally Harmonize System (GHS)", SABS, Pretoria, 2008.
6. SABS, "SANS 10160: part 4: Basis of structural design and actions for buildings and industrial structures Part 4 seismic actions and general requirements for building", SABS, Pretoria, 2011.
7. SABS, "SANS10313: Protection against lightning – physical damage to structure and life hazard", SABS, Pretoria, 2012.
8. DNV-GL, Recommended Practice – Safety, operation and performance of grid-connected energy storage systems, DNVGL-RP-0043, September 2017
9. IEC, "IEC 62619 – Secondary cells and batteries containing alkaline or other non-acid electrolytes – Safety Requirements or secondary lithium cells and batteries for use in industrial applications", Feb 2017.
10. Hare, G. "Batteries – What's the Problem", Brandz, Fire and Emergency New Zealand Research Report 174. Jan 2020.
11. DNV-GL, 'McMicken Battery Energy Storage Systems Event – Technical Analysis and Recommendations, July 2020.
12. DNV-GL, 'Quantitative risk analysis for battery energy storage sites', 17 May 2019.
13. Energy Response Solutions, "Energy Storage Systems Safety - Comparing Vanadium Redox Flow and Lithium-Ion Based Systems ", Aug 2017.
14. Wikipedia, "Vanadium redox Batteries".
15. Bushveld Minerals and Energy, "Energy Storage and Vanadium Redox Flow batteries 101", 13 November 2018.
16. Whitehead A.H, Rabbow T.J, Trampert M, Pokorny P, "Critical safety features of the vanadium redox flow battery", Volume 351, 31 May 2017, Pages 1-7.
17. ESI AFRICA, "The vanadium redox flow battery, a leading technology in energy storage", Aug 8, 2019.
18. Noak J, Roznyatovskaya N, Menictas C and Skyllas-Kazacos AM, "Redox flow batteries for renewable energy storage", 21 Jan 2020.
19. Global Sustainable Energy Solutions, "Battery Storage Systems: What are their chemical hazards?", GSES Technical Papers, 2016, www.gses.com.au.
20. University of Washington Environment Health and Safety, "Lithium Battery Safety", www.ehs.washington.edu, April 2018.
21. Hesler, P & Travers, K.A., "Lithium-ion Battery Energy Storage Systems - The risks and how to manage them", AIG, 17 July 2019.
22. Verhaegh, N., van de Burgt, J., Tiggelman, A and Mulder G. "STALLION Handbook on safety assessment for large Scale, stationary, grid-connected Lithium -ion energy Storage Systems", Arnhem, March 2015.
23. TESLA, Battery Emergency Response Guide (Lithium-ion), 17 Dec 2019.
24. Tesla, MegaPack – Datasheet Safety Overview.
25. St John, J, "SunEdison Buys Solar Grid Storage for Battery-Backed PV and Wind Power", Greentechmedia.com, 5 March 2015.
26. Energy Storage Association, "Operation Risk Management in the US Energy Storage Industry: Lithium-Ion Fire and Thermal Event Safety", Sept 2019.

APPENDIX A

Preliminary Approximations of Absolute WORST-CASE Consequence and Risk Modelling (Modelling done using DNV-GL software PHAST RISK 6.7)

PLEASE NOTE – the modelling, especially the noxious smoke modelling, is an approximation.

Approximation of WORST-CASE Radiation Levels from an Entire Container on Fire

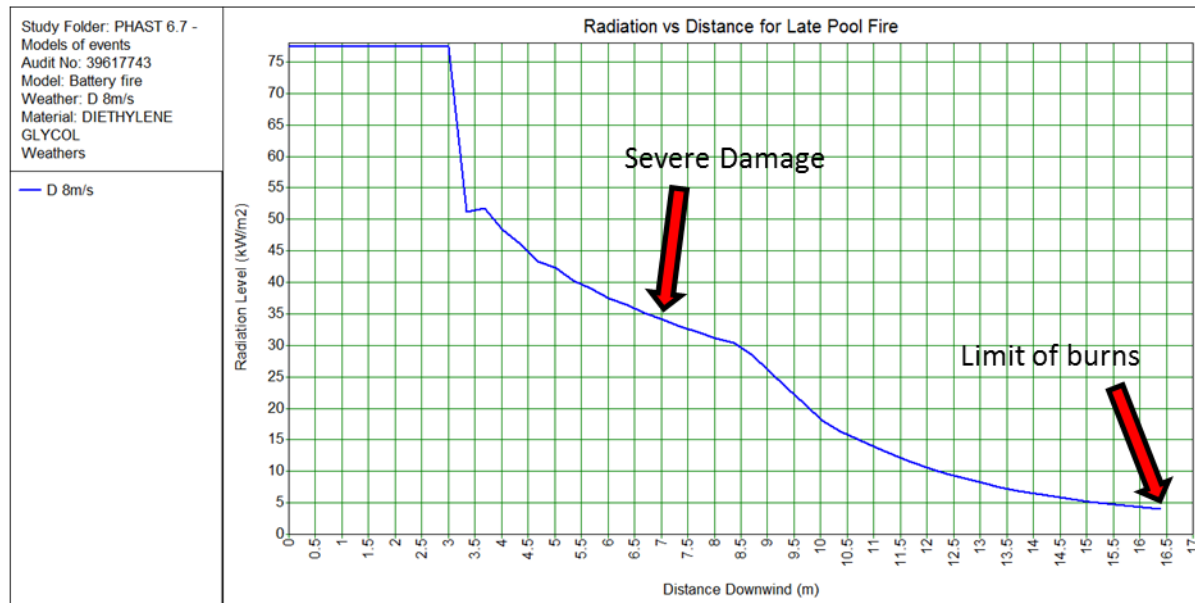

Approximation of WORST-CASE Explosion Over pressures from an Entire Container Explosion

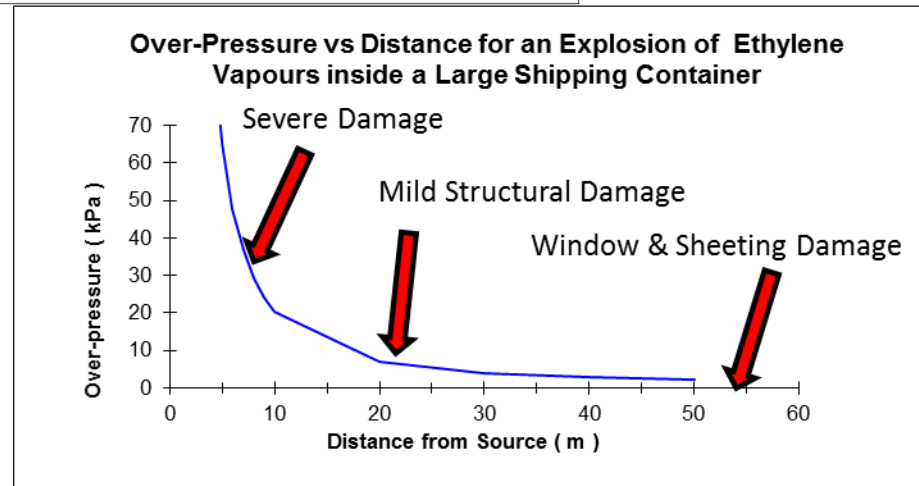
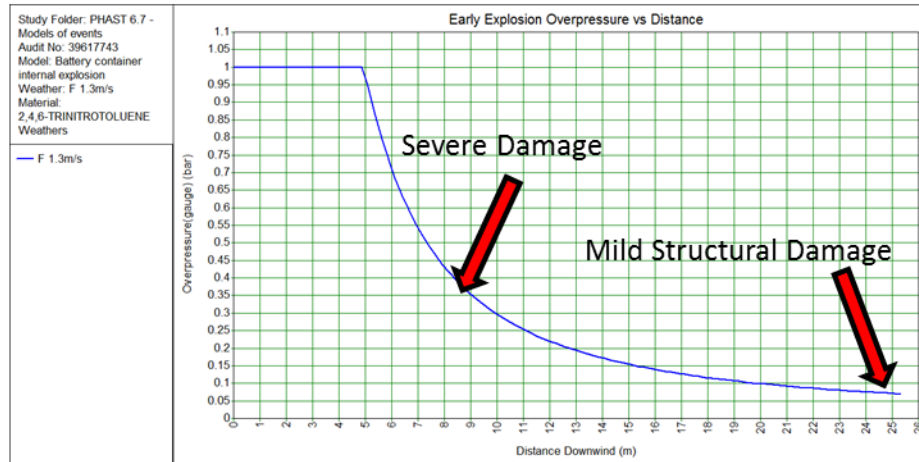

Approximation of Maximum Concentration of Carbon Monoxide in Noxious Smoke Cloud from Lithium Container Fire
200ppm is the Nuisance Level, 500ppm is potentially harmful

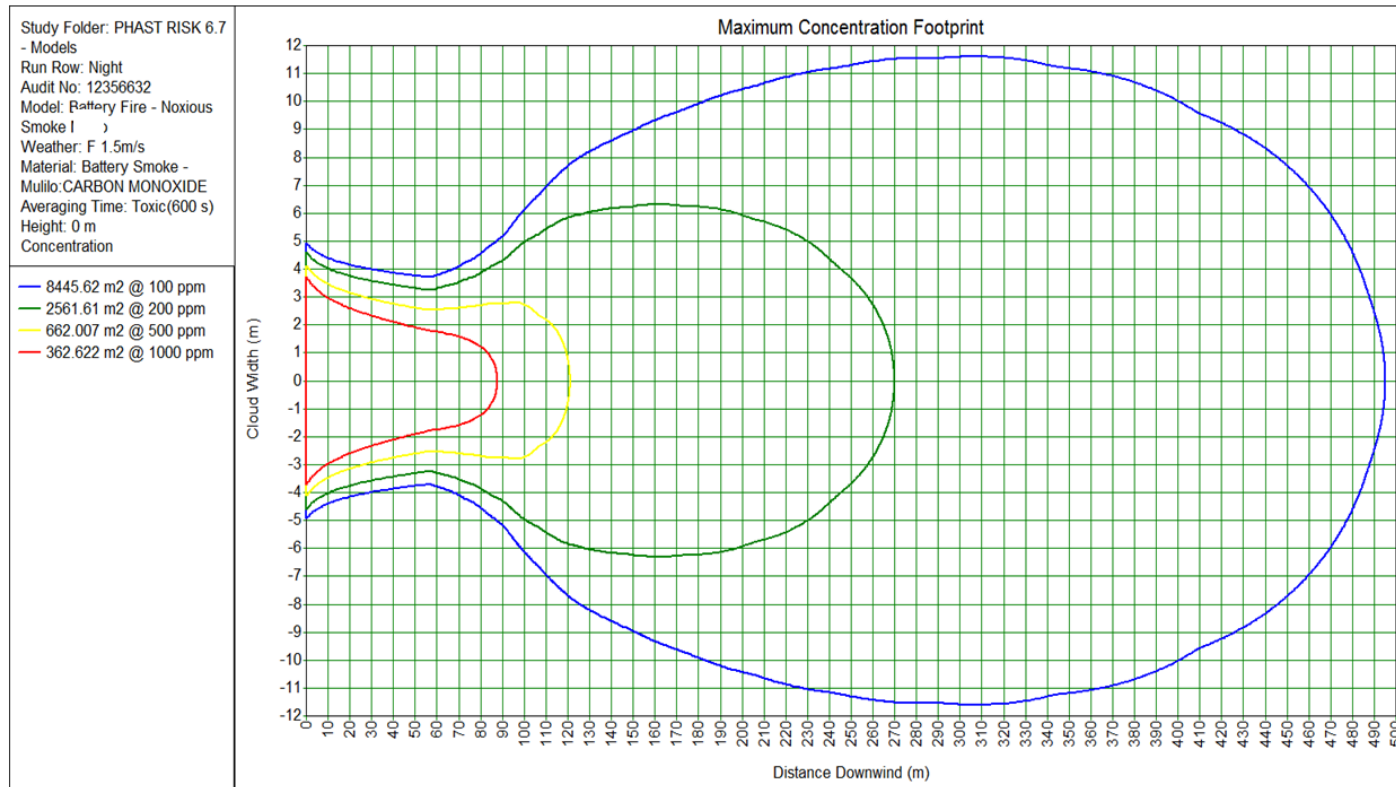

APPENDIX B: SPECIALIST STATEMENT OF INDEPENDENCE



environmental affairs

Department:
Environmental Affairs
REPUBLIC OF SOUTH AFRICA

DETAILS OF THE SPECIALIST, DECLARATION OF INTEREST AND UNDERTAKING UNDER OATH

	(For official use only)
File Reference Number:	
NEAS Reference Number:	DEA/EIA/
Date Received:	

Application for authorisation in terms of the National Environmental Management Act, Act No. 107 of 1998, as amended and the Environmental Impact Assessment (EIA) Regulations, 2014, as amended (the Regulations)

PROJECT TITLE

Scoping and Environmental Impact Assessment Processes for the Proposed Development of 12 Solar Photovoltaic (PV) Facilities and associated infrastructure (i.e. Kudu Solar Facility 1 - 12), near De Aar, Northern Cape

Kindly note the following:

1. This form must always be used for applications that must be subjected to Basic Assessment or Scoping & Environmental Impact Reporting where this Department is the Competent Authority.
2. This form is current as of 01 September 2018. It is the responsibility of the Applicant / Environmental Assessment Practitioner (EAP) to ascertain whether subsequent versions of the form have been published or produced by the Competent Authority. The latest available Departmental templates are available at <https://www.environment.gov.za/documents/forms>.
3. A copy of this form containing original signatures must be appended to all Draft and Final Reports submitted to the department for consideration.
4. All documentation delivered to the physical address contained in this form must be delivered during the official Departmental Officer Hours which is visible on the Departmental gate.
5. All EIA related documents (includes application forms, reports or any EIA related submissions) that are faxed; emailed; delivered to Security or placed in the Departmental Tender Box will not be accepted, only hardcopy submissions are accepted.

Departmental Details

Postal address:

Department of Environmental Affairs
Attention: Chief Director: Integrated Environmental Authorisations
Private Bag X447
Pretoria
0001

Physical address:

Department of Environmental Affairs
Attention: Chief Director: Integrated Environmental Authorisations
Environment House
473 Steve Biko Road
Arcadia

Queries must be directed to the Directorate: Coordination, Strategic Planning and Support at:
Email: EIAdmin@environment.gov.za

1. SPECIALIST INFORMATION

Specialist Company Name:	ISHECONcc		
B-BBEE	Contribution level (indicate 1 to 8 or non-compliant)	4	Percentage Procurement recognition
Specialist name:	Debra Catherine Mitchell		
Specialist Qualifications:	MSc Chem Eng		
Professional affiliation/registration:	ECSA Professional Engineer		
Physical address:	Building H4, Pinelands Office Park, Maxwell Drv, Moddefontein		
Postal address:	P O Box 320, Modderfontein		
Postal code:	1645	Cell:	+27 (0)82 428 8844
Telephone:	+27 (0)11 201 4783	Fax:	+27 (0)86 549 0878
E-mail:	mitchelld@isheocn.co.za		

2. DECLARATION BY THE SPECIALIST

I, DEBRA CATHERINE MITCHELL, declare that –

- I act as the independent specialist in this application;
- I will perform the work relating to the application in an objective manner, even if this results in views and findings that are not favourable to the applicant;
- I declare that there are no circumstances that may compromise my objectivity in performing such work;
- I have expertise in conducting the specialist report relevant to this application, including knowledge of the Act, Regulations and any guidelines that have relevance to the proposed activity;
- I will comply with the Act, Regulations and all other applicable legislation;
- I have no, and will not engage in, conflicting interests in the undertaking of the activity;
- I undertake to disclose to the applicant and the competent authority all material information in my possession that reasonably has or may have the potential of influencing - any decision to be taken with respect to the application by the competent authority; and - the objectivity of any report, plan or document to be prepared by myself for submission to the competent authority;
- all the particulars furnished by me in this form are true and correct; and
- I realise that a false declaration is an offence in terms of regulation 48 and is punishable in terms of section 24F of the Act.



Signature of the Specialist

ISHECONcc

Name of Company:

12 JUNE 2023

Date

Details of Specialist, Declaration and Undertaking Under Oath

3. UNDERTAKING UNDER OATH/ AFFIRMATION

I, DEBRA CATHERINE MITCHELL, swear under oath / affirm that all the information submitted or to be submitted for the purposes of this application is true and correct.



Signature of the Specialist

ISHECONcc

Name of Company

12 JUNE 2023

Date



Signature of the Commissioner of Oaths

12 JUNE 2023

Date

Dennis Richard Diamond
COMMISSIONER OF OATHS
9/1/8/2 Randburg (A15) 14 March 2001
Fish Eagle 2 Office Park
Unit 12 Kingfisher Crescent
Tel. (011) 867-4326 Fax: (011) 867-1557



CHAPTER 16: Geohydrology Assessment

GEOHYDROLOGY ASSESSMENT:

Scoping and Environmental Impact Assessment (EIA) Process for the Proposed Development of a Solar Photovoltaic Facility (Kudu Solar Facility 7) and associated infrastructure, near De Aar, Northern Cape Province

<i>Report prepared for:</i>	<i>Report prepared by:</i>
CSIR – Environmental Management Services P O Box 320 Stellenbosch 7599 South Africa	Christel van Staden; Dale Barrow; Shane Teek & Louis Jonk GEOSS South Africa (Pty) Ltd P.O. Box 12412 Die Boord, Stellenbosch 7613 South Africa Stellenbosch 7600 South Africa

Version 0: 22 March 2023

Version 1: July 2023

EXECUTIVE SUMMARY

GEOSS South Arica (Pty) Ltd was appointed to complete a geohydrology impact assessment for the proposed Kudu Solar Facilities project located approximately 60 km to the northeast of De Aar in the Northern Cape Province. This geohydrological assessment is aimed at determining the potential for groundwater to be used for construction and operational purposes, as well as the risks to nearby groundwater users which are mainly livestock and occupants on the farms.

The proposed site is directly underlain by three main lithologies (rock/soil types):

- Various shales and combinations of purple, red, green and grey, mudstone or sandstones of the Tierberg Formation (Pt) and undifferentiated sediments of the Adelaide Subgroup (predominantly horizontal layers).
- Large dolerite sill structures, which have intruded into the mudstone and sandstone layers in the area (Jd), (including associated dyke structures).
- Locally developed areas of alluvial and/or other quaternary deposits.

The Kudu Solar Facility 7 and surrounding area is underlain by two aquifers with regional groundwater electrical conductivity (EC) ranges between 70 and 300 mS/m.

- A fractured aquifer with an average borehole yield potential of 0.5 – 2.0 L/s.
- An intergranular and fractured aquifer, although there is currently no known information on this aquifer.

The water requirements for the proposed Kudu Solar Facility 7 are as follows:

- Construction phase: 18 000 m³/a (0.6 L/s)
- Operational phase: 2 000 m³/a (0.06 L/s).

The assessment identified the following main impacts along with the significance of each phase pre and post mitigation shown in the table below.

Construction Phase

- Potential impact 1: Potential lowering of the groundwater level.
- Potential impact 2: Potential impact on groundwater quality as a result of accidental oil spillages or fuel leakages.

Operational Phase

- Potential impact 3: Potential lowering of the groundwater level.
- Potential impact 4: Potential impact on groundwater quality as a result of using cleaning agents for cleaning the solar panels.

- Potential impact 5: Groundwater quality deterioration as a result of electrolyte that will be used for the Battery Energy Storage System (BESS).

Decommissioning Phase

- Potential impact 6: Potential impact on groundwater quality as a result of accidental oil spillages or fuel leakages.
- Potential impact 7: Potential lowering of the groundwater level.

Cumulative impacts identified were identical to the individual impacts of the individual Kudu Solar Facility 7, with the only changes occurring in the duration, scale, and likelihood of the impacts occurring.

Phase	Overall Impact Significance (Pre-Mitigation)	Overall Impact Significance (Post Mitigation)
Construction	Moderate to Very Low	Low-Very Low
Operational	Moderate to Very Low	Low-Very Low
Decommissioning	Very Low	Very Low
Cumulative Impacts		
Cumulative - Construction	Moderate to Very Low	Low-Very Low
Cumulative - Operational	Moderate to Very Low	Low-Very Low
Cumulative - Decommissioning	Very Low	Very Low

A summary of the main mitigation measures identified for the developments include:

- Inclusion of a borehole monitoring program
- Adherence to the safe borehole yield values
- The use of environmentally friendly cleaning agents
- Construction of BESS with a 50-meter buffer from any boreholes
- The addition of effective bunding and secondary containment around BESS facilities
- Vehicles must be regularly serviced and maintained.
- Inclusion of drip trays for long standing vehicles.
- Diesel fuel storage tanks should be above ground on an impermeable concrete surface in a bunded area.
- Construction vehicles and equipment should also be refuelled on an impermeable surface. Spillages are to be removed with correct disposal procedures.
- Proof of disposal retained on file for auditing purposes.

The distribution of boreholes across the proposed area have been assessed in relation to the farm portions with special reference to the allowable General Authorisation volumes for each of the constituent farm portions that comprise the proposed Kudu Solar Facility 7 and surrounds. Furthermore, the hydrocensus has confirmed there are several boreholes on site and/or on neighbouring properties, with HBH18, HBH19, and HBH20 representing potentially viable sources of groundwater for the development of Solar Facility 7. The use of this/these borehole/s would/will depend on the operational requirements of the facility, negotiations with the landowners and proximity to the facility.

Considering that the required peak (construction) water supply is 18 000 m³/a (0.60 L/s) for the proposed Kudu Solar Facility 7, the required water volumes should be readily available and could be supplied by the regional aquifer yield (0.5 – 2.0 L/s).

The demand for the facility could potentially be met by abstraction from Farm 2/40 even if Solar Facilities 6 and 7 are constructed simultaneously under the available GA volume of farm portion 2/40. Furthermore, the cumulative demands of construction (~4.6 L/s) for all twelve planned Kudu Solar Facilities (if developed simultaneously) exceeds the regional yield potential of the underlying aquifer (0.5 – 2.0 L/s). Therefore, groundwater exploration (including hydrocensus, lineament mapping and geophysics) on adjacent properties should be undertaken for additional supply to meet the demands. Alternatively, to source all the water from this farm portion, a Water Use License Application will be required to meet the demands of the construction period

Given the findings of this assessment, an overall significance rating post mitigation is given as **Low to Very Low** and the development of the proposed Kudu Solar Facility is authorised to continue on condition the following recommendations are adhered to:

- In the case that multiple projects are constructed simultaneously, adherence to recommended mitigation measures should be strictly followed to prevent over abstraction.
- In the event that groundwater is to be used in the project, the proposed monitoring plan should be followed with a special focus on groundwater level monitoring to ensure that the aquifer is not over abstracted and falls to levels below historic borehole depths.
- All proposed impact mitigation measures are to be implemented during the development of the project. These include the use of environmentally safe cleaning agents, the construction of BESS facilities 50m from any boreholes along with appropriate bunding and secondary containment, and the recommended precautionary approaches aimed at preventing oil spills and fuel leaks.



CONTENTS

16. GEOHYDROLOGY ASSESSMENT	16-11
16.1 Introduction	16-11
16.1.1 Scope, Purpose and Objectives of this Specialist Report	16-13
16.1.2 Details of Specialist	16-13
16.1.3 Terms of Reference	16-13
16.2 Approach and Methodology	16-15
16.2.1 Information Sources	16-15
16.2.2 Assumptions, Knowledge Gaps and Limitations	16-15
16.2.3 Consultation Processes Undertaken	16-16
16.3 Description of Project Aspects relevant to Hydrogeological Specialist Study	16-17
16.4 Baseline Environmental Description	16-18
16.4.1 Study Area Definition	16-18
16.4.2 General Description	16-18
16.4.3 Project Specific Description	16-21
16.4.3.1 Climate	16-21
16.4.3.2 Regional Geology	16-22
16.4.3.3 Regional Hydrogeology	16-22
16.4.3.4 Aquifer Vulnerability (DRASTIC)	16-23
16.4.4 Site Specific and Existing Groundwater Information	16-24
16.4.4.1 NGA Database	16-24
16.4.4.2 Hydrocensus	16-25
16.4.4.3 Groundwater Quality	16-27
16.4.4.3.1 SANS241-1:2015: Drinking water standards	16-27
16.4.4.3.2 DWA (1998): Drinking Water Assessment Guide	16-28
16.4.4.4 Water level elevation maps	16-30
16.4.5 Identification of Environmental Sensitivities	16-36
16.4.5.1 Sensitivities identified by the National Web-Based Environmental Screening Tool	16-36
16.4.5.2 Specialist Sensitivity Analysis and Verification	16-36
16.4.5.3 Sensitivity Analysis Summary Statement	16-37
16.5 Issues, Risks and Impacts	16-39
16.5.1 Identification of Potential Impacts/Risks	16-39
16.5.2 Summary of Issues identified during the Public Consultation Phase	16-40

16.6	Impact Assessment	16-48
16.6.1	Potential Impacts during the Construction Phase	16-48
16.6.1.1	Impact 1: Groundwater impact as a result of over-abstraction from construction requirements	16-48
16.6.2	Potential Impacts during the Operational Phase	16-51
16.6.2.1	Impact 1: Groundwater impact as a result of over-abstraction from operational requirements	16-51
16.6.2.2	Impact 2: Potential impact on groundwater quality as a result of using cleaning agents	16-51
16.6.2.3	Impact 3: Potential impact on groundwater quality as a result of electrolyte that will be used for the BESS	16-51
16.6.3	Potential Impacts during the Decommissioning Phase	16-54
16.6.3.1	Impact 1: Potential Impact on Groundwater Quality as a result of Accidental Oil Spillages or Fuel Leakages	16-54
16.6.3.2	Impact 2: Groundwater impact as a result of over-abstraction from decommissioning requirements	16-54
16.6.4	Potential Cumulative Impacts	16-56
16.6.4.1	Impact 1: Groundwater impact as a result of over-abstraction from construction, operation, and decommissioning requirements	16-58
16.6.4.2	Impact 2: Potential Impact on Groundwater Quality as a result of Accidental Oil Spillages or Fuel Leakages during the construction and decommissioning phases	16-59
16.6.4.3	Impact 3: Potential impact on groundwater quality as a result of using cleaning agents during the operational phase	16-60
16.6.4.4	Impact 4: Potential impact on groundwater quality as a result of electrolyte that will be used for the BESS during the operational phase	16-60
16.6.4.5	Concluding Cumulative Summary: Potential impacts during the construction, operational, and decommissioning phases of other wind and solar, and EGI projects within a 30 km radius.	16-60
16.6.4.6	Impact Summary Tables: Cumulative Impacts	16-61
16.6.5	No-go Alternatives	16-64
16.6.6	Battery Energy Storage System	16-64
16.7	Impact Assessment Summary	16-65
16.8	Legislative and Permit Requirements	16-65
16.9	Environmental Management Programme Inputs	16-68
16.9.1	Proposed Monitoring Plan:	16-69
16.9.1.1	Groundwater Level Monitoring	16-70
16.9.1.2	Groundwater Quality Monitoring	16-70
16.9.1.3	Sample Collection, Preservation and Submission	16-71
16.9.1.4	Monitoring Frequency and Parameter Analysis	16-71
16.10	Final Specialist Statement and Authorisation Recommendation	16-75
16.10.1	Statement and Reasoned Opinion	16-75
16.10.2	EA Condition Recommendations	16-76
16.11	References	16-77

APPENDICES	16-79
APPENDIX A - SPECIALIST EXPERTISE	16-79
APPENDIX B - SPECIALIST STATEMENT OF INDEPENDENCE	16-83
APPENDIX C - SITE SENSITIVITY VERIFICATION	16-83
APPENDIX D - IMPACT ASSESSMENT METHODOLOGY	16-93
APPENDIX E - COMPLIANCE WITH THE APPENDIX 6 OF THE 2014 EIA REGULATIONS (AS AMENDED)	16-98
APPENDIX F - OTHER RENEWABLE ENERGY PROJECTS WITHIN 30 KM OF THE KUDU SOLAR PV FACILITY	16-100



Table 16-1: Information sources used to assess the Groundwater for the proposed Kudu Solar Facility project.	16-15
Table 16-2: Geological formations within the study area listed in order of relative age.	16-22
Table 16-3: Summary of NGA borehole.	16-25
Table 16-4 : Summary of Boreholes in the study area.	16-25
Table 16-5: Classification table for specific limits for domestic water standards	16-27
Table 16-6: Production borehole results classified according the SANS241-1:2015	16-27
Table 16-7: Classification table for the groundwater results (DWAF, 1998)	16-28
Table 16-8: Classified production borehole results according to DWAF 1998.	16-28
Table 16-9: Table showing a summary of the main comments received from stakeholders during the Public Consultation Phase during Scoping with key responses	16-41
Table 16-10: Extent and water requirements of the Kudu Solar Facility 7	16-48
Table 16-11: Impact Summary Tables: Construction Phase	16-50
Table 16-12: Impact Summary Tables: Operational Phase	16-52
Table 16-13: Impact Summary Tables: Decommissioning Phase	16-55
Table 16-14: Summary of anticipated water requirements of solar facilities during construction and operational phases.	16-59
Table 16-15: Overall Impact Significance	16-65
Table 16-16: Farm portions affected by the proposed Kudu Solar Facilities; relevant portion highlighted in blue.	16-67
Table 16-17: General locations for proposed monitoring points.	16-69
Table 16-18: Proposed groundwater monitoring parameters and their recommended frequency.	16-72
Table 16-19: Approved renewable energy projects, located within 30 km of the proposed Kudu Solar Facility.	16-100

FIGURES

- Figure 16-1: Monthly average air temperature for the Kudu Solar Facility study area (Schulze, 2009). 16-21
 Figure 16-2: Monthly median rainfall and evaporation distribution for the Kudu Solar Facility study area (Schulze, 2009). _____ 16-21
 Figure 16-3: Correlation between surface topography and groundwater elevation. _____ 16-30
 Figure 16-4: Schematic representation of the proposed general borehole construction. _____ 16-70
 Figure 16-5: Guide to assessing risk/impact significance as a result of consequence and probability. 16-96

MAPS

- Map 16-1: Locality of the proposed Kudu Solar Facility development, near De Aar, Northern Cape. 16-12
 Map 16-2: The study area delineating the study area for the 12 Kudu Solar Facilities, property boundaries, hydrocensus boreholes and the NGA borehole on a 1:50 000 scale topocadastral map (3024AA, 3024AB, 3024AC, 3024AD, 3024BA, 3024BC). Note that this report is focused on Kudu Solar Facility 7. _____ 16-19
 Map 16-3: Aerial view delineating the study area of the 12 Kudu Solar Facilities, hydrocensus boreholes and the NGA borehole. Note that this report is focused on Kudu Solar Facility 7. _____ 16-20
 Map 16-4: Geological setting of the study area for the Kudu Solar Facilities. (CGS (1997) map: 1:250 000 scale Colesberg). Note that this report is focused on Kudu Solar Facility 7. _____ 16-31
 Map 16-5: Regional aquifer yield (DWAF, 2005) and borehole yields (L/s) in the study area for the Kudu Solar Facilities. Note that this report is focused on Kudu Solar Facility 7. _____ 16-32
 Map 16-6: Regional groundwater quality (mS/m) from DWAF (2005) and borehole groundwater quality (EC in mS/m) in the study area for the Kudu Solar Facilities. Note that this report is focused on Kudu Solar Facility 7. _____ 16-33
 Map 16-7: Vulnerability rating (DWAF, 2005) and groundwater depths (mbgl) in the study area for the Kudu Solar Facilities. Note that this report is focused on Kudu Solar Facility 7. _____ 16-34
 Map 16-8: Groundwater contour map based on the March 2022 field measurements in the study area. Note that this report is focused on Kudu Solar Facility 7. _____ 16-35
 Map 16-9: Detailed Layout of Kudu Solar Facility 7. _____ 16-38
 Map 16-10: Map showing the proposed Kudu Solar PV Facility in relation to other local authorised, in process or operational renewable projects _____ 16-57
 Map 16-11: Proposed monitoring borehole locations from an aerial view. _____ 16-74

ABBREVIATIONS

Abbreviations	
BH	Borehole
CGS	Council for Geoscience
DHSWS	Department of Human Settlements, Water and Sanitation
DWA	Department of Water Affairs (used to be Department of Water Affairs and Forestry)
DWAF	Department of Water Affairs and Forestry
DWS	Department of Water and Sanitation
EC	electrical conductivity
GIS	Geographic Information System
L/s	litres per second
m	metres
mbch	meters below collar height
mbgl	metres below ground level
mm	millimetre
mS/m	milli-Siemens per metre
NGA	National Groundwater Archive
WARMS	Water Authorisation and Registration Management System

GLOSSARY

Definitions	
Aquifer	A geological formation, which has structures or textures that hold water or permit appreciable water movement through them [from National Water Act (Act No. 36 of 1998)].
Borehole	Includes a well, excavation, or any other artificially constructed or improved groundwater cavity which can be used for the purpose of intercepting, collecting or storing water from an aquifer; observing or collecting data and information on water in an aquifer; or recharging an aquifer [from National Water Act (Act No. 36 of 1998)].
DRASTIC	An acronym for a groundwater vulnerability assessment methodology: D = depth to groundwater / R = recharge / A = aquifer media type / S = soil type / T = topography / I = impact of the unsaturated zone / C = hydraulic conductivity. The methodology uses a rating and weighting approach and was developed by the Environmental Protection Agency (USA)
Electrical Conductivity	The ability of groundwater to conduct electrical current, due to the presence of charged ionic species in solution (Freeze and Cherry, 1979).
Fractured aquifer	Fissured and fractured bedrock resulting from decompression and/or tectonic action. Groundwater occurs predominantly within fissures and fractures.
Groundwater	Water found in the subsurface in the saturated zone below the water table or piezometric surface i.e. the water table marks the upper surface of groundwater systems.
Inferred	Where a geological contact or fault is believed to exist however is not confirmed.
Intergranular aquifer	Generally unconsolidated but occasionally semi-consolidated aquifers. Groundwater occurs within intergranular interstices in porous medium. Typically occur as alluvial deposits along river terraces.
Intergranular and fractured aquifers	Largely medium to coarse grained granite, weathered to varying thicknesses, with groundwater contained in intergranular interstices in the saturated zone, and in jointed and occasionally fractured bedrock.
Vulnerability	The tendency or likelihood for contaminants to reach a specified position in the ground-water system after introduction at some location above the uppermost aquifer (National Research Council, 1993).

16. GEOHYDROLOGY ASSESSMENT

This report serves as the Groundwater Impact Assessment that was prepared as part of the Environmental Impact Assessment (EIA) Processes for the proposed development of 12 Solar Photovoltaic (PV) Facilities (Kudu Solar Facilities 1 - 12) and associated infrastructure, near De-Aar, Northern Cape Province (**Map**).

16.1 Introduction

GEOSS South Arica (Pty) Ltd was appointed to complete a geohydrology impact assessment for the proposed Kudu Solar Facilities project. This geohydrological assessment includes a review of groundwater characteristics and users in the area, with the aim of determining the potential for groundwater to be used for construction and operational purposes, as well as risk to nearby groundwater users.

The generation capacity of each proposed solar PV facility will range from 50 MWac to 350 MWac. Four PV facilities each have a capacity of more than 150 MWac but up to 350 MWac. Eight PV facilities each have an estimated capacity of up to 150 MWac. Generally, the water requirements are as follows:

For the facilities (i.e. eight) with an estimated capacity of up to 150 MWac:

- Construction Phase: The total water requirement is estimated to be 9 000 m³/a per solar facility thus a total 72 000 m³/a. The construction phase should last approximately 18 months.
- Operational Phase: The total water requirement is estimated to be 1 000 m³/a per solar facility thus a total of 8 000 m³/a for the operational phase which should last approximately 20 years.

For the facilities (i.e. four) with an estimated capacity of more than 150 MWac but up to 350 MWac:

- Construction Phase: The total water requirement is estimated to be 18 000 m³/a per solar facility thus a total 72 000 m³/a. The construction phase should last approximately 18 months.
- Operational Phase: The total water requirement is estimated to be 2 000 m³/a per solar facility thus a total of 8 000 m³/a for the operational phase which should last approximately 20 years.

For the capacity and water requirement of this facility see Table 16-10. The water requirements differ depending on the capacity of the facility, and this is elaborated upon for this specific facility in subsequent sections (Section 16.5 – 16.9).

This report outlines the work completed to assess the likelihood of using groundwater for the proposed Kudu Solar Facility development, including the potential impact the development may have on groundwater resources in the area.

Separate reports have been compiled for each PV facility. This report only covers the Kudu Solar Facility 7 and associated infrastructure (hereafter referred to as the “Kudu Solar Facility” or “proposed project”).

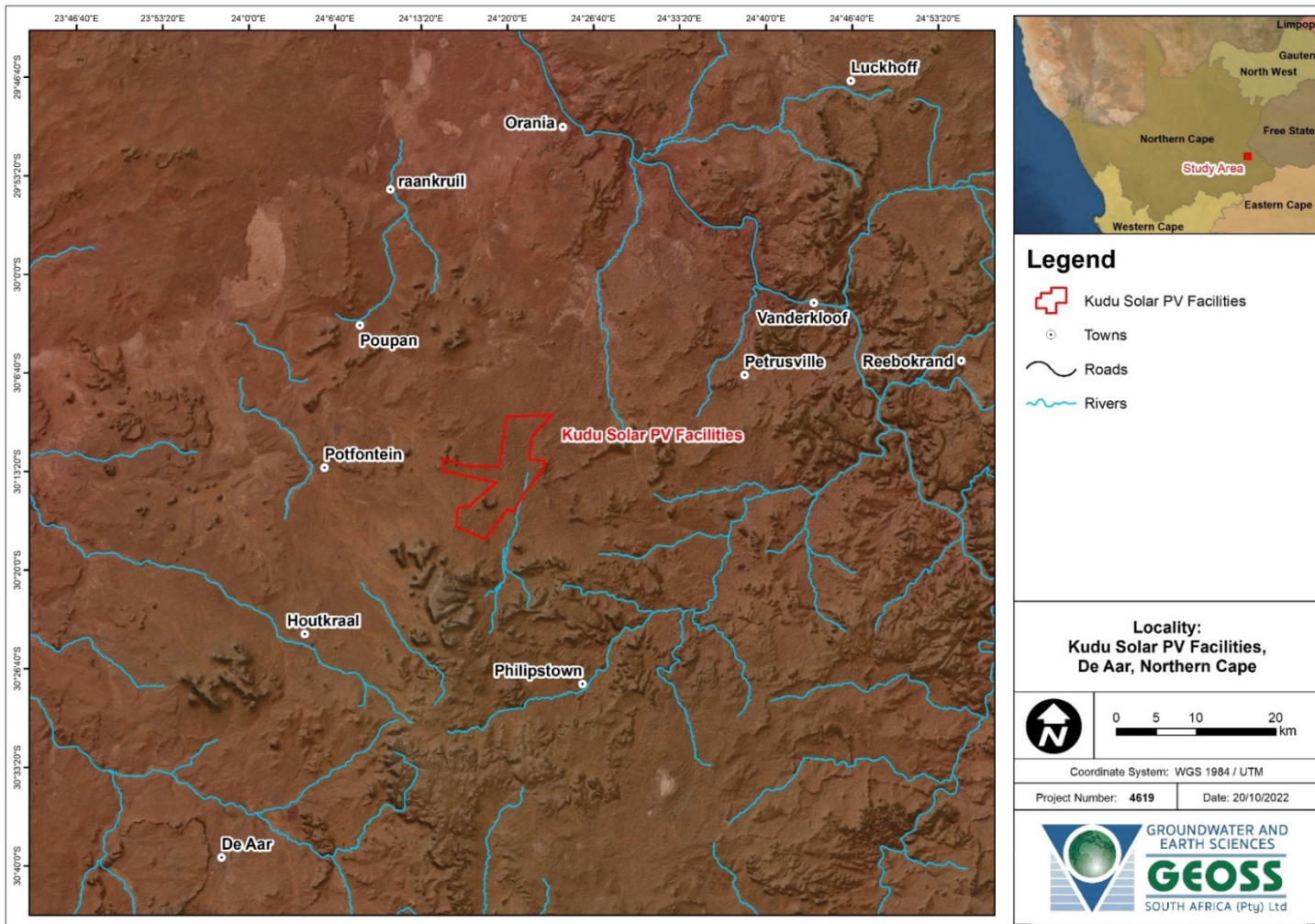

Map 16-1: Locality of the proposed Kudu Solar Facility development, near De Aar, Northern Cape.

16.1.1 Scope, Purpose and Objectives of this Specialist Report

The scope of work is to provide groundwater specialist services with regard to the tasks outlined below:

- Assessment for groundwater to be used for construction and operational purposes for the proposed project, including solar panel cleaning.
- Assessment of the impact on geohydrological resources as a result of the proposed development.
- Provide recommendations to minimize or mitigate impacts.
- Confirm what type of authorisation is required to make use of the groundwater.

The results of the investigation are presented in this report along with the data analysis and interpretation.

16.1.2 Details of Specialist

This specialist assessment has been undertaken by Dale Barrow, Christel van Staden, Shane Teek and Louis Jonk of GEOSS South Africa. Dale Barrow is registered with the South African Council for Natural and Scientific Professions (SACNASP), as a Professional Natural Scientist, with Registration Number 400289/13 in the field of Earth Sciences. Christel van Staden is registered as a candidate with the SACNASP, with Registration Number 122591. Shane Teek is registered as a candidate with the SACNASP, with Registration Number 126397. Louis Jonk is registered as a Professional Natural Scientist with the SACNASP, with Registration Number 121278. A curriculum vitae is included for all parties in Appendix A of this Specialist Assessment.

In addition, a signed specialist statement of independence is included in Appendix B of this specialist input report.

16.1.3 Terms of Reference

The procedure adopted for this Impact Assessment Level study involved an initial desktop study of all available data and databases. The study involved obtaining and reviewing all relevant data to the proposed projects. This included analysing data from the National Groundwater Archive (NGA), Water Authorisation and Registration Management System (WARMS) and GEOSS's internal database, as well as groundwater yield, groundwater chemistry and geological maps of the area. A site visit was also carried out on the 23rd and 24th of March 2022 to conduct a hydrocensus to obtain further groundwater use information. The hydrocensus data was also analysed using geohydrological and spatial analysis methods to address the project objectives. A summary of the sensitivities and high-level impacts was also included.

The following terms of reference applies to the assessment:

- Obtain data for all the PV sites (i.e. obtain data from the NGA (and associated groundwater use databases) and internal GEOSS database (which includes information relevant to the site). Obtain data from the local Department of Water and Sanitation (DWS) monitoring boreholes. Obtain relevant geological maps and geohydrological maps, as well as relevant groundwater reports.

- Undertake a site visit in order to identify the level of sensitivity relating to geohydrology, and to complete a hydrocensus.
- Analyse the hydrocensus data using geohydrological and spatial analysis methods to address the project objectives.
- Compile a Geohydrology Impact Assessment in compliance with Appendix 6 of the 2014 National Environmental Management Act (Act 107 of 1998, as amended) (NEMA) EIA Regulations (as amended) and Part A of the Assessment Protocols published in GN 320. The Specialist Assessment must also be in adherence to any additional relevant legislation and guidelines that may be deemed necessary, as applicable.
- Determination, description and mapping of the baseline environmental condition and sensitivity of the study area relating to geohydrology (including hydrogeological characterisation of aquifers (types, sensitivity, vulnerability)), and groundwater (quality, quantity, use, potential for industrial or domestic use) in the area surrounding the proposed development. Specify set-backs or buffers, and provide clear reasons for these recommendations.
- Provide review input on the preferred infrastructure layout following the sensitivity analysis and layout identification.
- Identify relevant permits that may be required and additional protocols and/or licensing requirements that are relevant to the project and the implications thereof, if any.
- A description of assumptions and limitations used.
- Identify significant features or disturbances within the proposed project study area and define any environmental risks in terms of geohydrology and the proposed project infrastructure.
- Confirm what type of authorisation or licence is required to make use of the groundwater.
- Identify and assess the potential direct, indirect and cumulative impacts of the proposed development geohydrology.
- Provide recommendations with regards to potential monitoring programmes.
- Determine mitigation and/or management measures for inclusion in the Environmental Management Programme (EMPr) which could be implemented to as far as possible reduce the effect of negative impacts and enhance the effect of positive impacts. Also identify best practice management actions, monitoring requirements, and rehabilitation guidelines for all identified impacts for inclusion in the EMPr.
- Review the Generic EMPr for Substations (GN 435) and confirm if there are any specific environmental sensitivities or attributes present on the site and any resultant site-specific impact management outcomes and actions that need to be included.
- Provide a reasoned opinion indicating the acceptability of the proposed development and a recommendation if the development should go ahead or not.

16.2 Approach and Methodology

The specialist study was completed as follows:

- Task 1: Obtain all relevant data to the proposed projects (i.e. obtain data from NGA and associated groundwater use databases, e.g. WARMS, GEOSS internal database). Obtain any data from local DWS monitoring boreholes. Obtain relevant geological maps and geohydrological maps. Obtain relevant groundwater reports. Compile a project Geographic Information System (GIS).
- Task 2: Complete a site visit and a hydrocensus (i.e. visit boreholes and land owners to obtain information such as yields and to measure the field chemistry to assess the groundwater quality (pH, Electrical Conductivity (EC) and total dissolved solids (TDS)). The representative hydrocensus extends for a radius of 1 km from the study area.
- Task 3: Analyse the data, using geohydrological methods and address the questions raised in the project objectives.
- Task 4: Document the results in a report.

16.2.1 Information Sources

The information sources used in this study are listed in **Table**

Table 16-1: Information sources used to assess the Groundwater for the proposed Kudu Solar Facility project.

Data / Information	Source	Date	Type	Description
Geological Map	Council for Geosciences	1997	Spatial	1:250 000 scale Geological Map Series of 3024 Colesberg
Climatology and Geohydrology	Cape Farm Mapper	2009	Database	SA Atlas of Climatology and Geohydrology; obtained from Western Cape Government Agriculture
Groundwater recharge and vulnerability mapping	Conrad J. and Munch Z.	2007	Spatial	A National scale approach to groundwater recharge and vulnerability mapping
Hydrogeological map series	Department of Water Affairs and Forestry	2005	Spatial	Hydrogeological map series of the republic of South Africa
NGA Database	NGA	14 April 2022	Database and Spatial	Spatial delineation of NGA registered boreholes

16.2.2 Assumptions, Knowledge Gaps and Limitations

The following assumptions and limitations apply:

- A limitation experienced during this investigation was the fact that the area received extensive rainfall prior to and during the site visit. Due to the rain the roads were extremely wet and made progress in the field slow and also difficult. Some farmers did not give GEOSS permission to drive on certain roads on their properties as it would damage the roads and there was a high risk of the

vehicle getting stuck. Despite this, the field work conducted is deemed suitable for the study and meets the objectives of the study.

- The investigation was conducted during the rainfall season of the region. The data, therefore, does not reflect conditions that prevail during the drier portion of the year. It is not expected that this would affect the outcome of the assessment.
- The geohydrological assessment is based on available literature for the study area. This includes regional scale GIS datasets based on 1: 1 000 000.
- No drill records or yield test data exists for production or wind pump boreholes to clarify yields and geological logs.
- The acquisition of accurate groundwater levels proved to be difficult, therefore data was limited to information obtained from local parties. Nonetheless these limitations have not negatively impacted the conclusions of the study.
- The NGA data is available at a local scale, although is known to sometimes contain false information.
- Since the area earmarked for the development of PV 8 falls across the Remaining Extent of the Farm Annex Wolve Kuil No. 41 and Portion 1 (Wolve Kuil West) of the Farm Annex Wolve Kuil No. 41, the water requirement for PV 8 was calculated based on a ratio of 25:75 split between the two mentioned portions.
- Since the area earmarked for the development of PV 1 falls across the Remaining Extent of the Farm Bas Berg No. 88 and Remaining Extent of Portion 3 of the Farm Bas Berg No. 88, the water requirement for PV 1 was calculated based on a ratio of 75:25 split between the two mentioned portions.
- Since the area earmarked for the development of PV 2 falls across the Remaining Extent of the Farm Bas Berg No. 88 and Remaining Extent of Portion 3 of the Farm Bas Berg No. 88, the water requirement for PV 2 was calculated based on a ratio of 50:50 split between the two mentioned portions.
- Since the area earmarked for the development of PV 11 falls across the Portion 1 (Wolve Kuil West) of the Farm Annex Wolve Kuil No. 41 and Portion 2 of the Farm Wolve Kuil No. 43, the water requirement for PV 11 was calculated based on a ratio of 75:25 split between the two mentioned portions.

The information obtained was sufficient to provide comprehensive geohydrological characterization of the regional setting.

It must be noted that there are no areas on site that should be avoided from a groundwater sensitivity perspective.

16.2.3 Consultation Processes Undertaken

During the undertaking of the geohydrological and geotechnical¹ site verification process, all landowners were contacted to ensure that GEOSS was able to locate their boreholes and inspect the landforms across their properties. This was mainly to ensure consent was granted; this was achieved telephonically by Christel Van Staden of GEOSS South Africa.

¹ Note that a separate Geotechnical Assessment is included in Chapter 17 of this EIA Report.

16.3 Description of Project Aspects relevant to Hydrogeological Specialist Study

The Project Applicant intends to source water from the existing boreholes or to drill new boreholes to source groundwater (if available and if suitable) for the construction, operational and decommissioning phases (i.e. general construction use, concrete batching, cleaning of panels, drinking water, and domestic use). As a result, water pipelines may need to be constructed to transfer groundwater from identified waterpoints. Alternatively water may be transported by trucks from the identified water points to the sites (Map 16-2) Groundwater may also need to be stored on site in suitable, closed containers or reservoir tanks during the construction and operational phases. The compliance requirements in terms of the National Water Act (Act 36 of 1998) (NWA) are also assessed in terms of groundwater use. It must be noted that in terms of water supply options, the use of existing boreholes is the third option and drilling of new boreholes is the fourth option. The first option is to source water from the local municipality and the second is to source water from a third party.

Generally, groundwater can be impacted negatively in two manners, namely:

- Over-abstraction (where groundwater abstraction exceeds recharge rates) which can result in the alteration of groundwater flow directions and gradients, as well as quality.
- Quality deterioration (i.e. from anthropogenic activities negatively impacting groundwater quality).

There is currently limited groundwater abstraction taking place in relation to the size of the study area (based on regional datasets). Groundwater use volumes are generally low, and water is mostly used for drinking and livestock watering. The low rainfall and high evapotranspiration rates within the study area are a limiting factor for the recharge of the aquifer underlying the study area.

The groundwater requirement for the project can be met by using the existing boreholes. However, agreements will have to be put in place with the current land owners for the use of groundwater. These agreements will have to be legally valid documents and the necessary endorsements will be required from the DWS.

If no such agreements can be put in place, then additional new boreholes will need to be drilled on the relevant farm portions/developments, followed by complete geohydrological testing and an assessment, including yield and water quality testing, and then authorisation from DWS to use the groundwater will be required, as well as the necessary Environmental Assessment process (if required). This will be undertaken as a separate process, once more detailed information becomes available, outside of the current Application for Environmental Authorisation for the Solar PV Facility and associated infrastructure. This Geohydrology Assessment focuses on the third option, which is the use of existing boreholes within the study area. Some information is provided on the permitting requirements for new boreholes, where possible, but this is not the focus of this assessment.

The proposed project will also entail the development of a Battery Energy Storage System (BESS) at the PV Facility. Lithium Ion and Redox Flow BESS technologies were considered during this EIA Process. With any chemical storage (e.g. for the electrolyte needed for the Redox Flow BESS) there is always a risk of contamination to soils and groundwater. Additional information is provided in the impact assessment section of this report.

16.4 Baseline Environmental Description

16.4.1 Study Area Definition

The study area for all the proposed Kudu Solar Facilities 1 to 12 is the full extent of the eight affected farm properties on which the proposed PV Facilities will be constructed. The full extent of these properties has been assessed in this study in order to identify environmental sensitivities and no-go areas. The total study area for all the Kudu Solar Facilities 1 to 12 is approximately 8 150 hectares (ha).

At the commencement of this Scoping and EIA Process, the **Original Scoping Buildable Areas** which fall within the study area were identified by the Project Developer following the completion of high-level environmental screening based on the Screening Tool.

Following the identification of sensitivities during the Scoping Phase, the Project Developer considered such sensitivities and formulated the **Revised Scoping Buildable Areas**. The **Revised Scoping Buildable Areas** were used to inform the design of the layout, and further assessed during this EIA Phase of the project in order to identify the preferred development footprint of the proposed project on the approved site as contemplated in the accepted Scoping Report. The development footprint is where the actual development will be located, i.e. the footprint containing the PV solar arrays and associated infrastructure.

16.4.2 General Description

The nearest town to the proposed project is De Aar, approximately 60 km to the southwest. The landscape in the surrounding area is arid, with transported sands occurring widely along plains with dolerite sills (generally northwest of the study area) and mudstone, shale and sandstones (generally southeast of the study area) outcropping in areas of higher elevation. It is understood that the farms in the area are mainly used for livestock farming purposes. The major impact within the area is, therefore, the abstraction of ground water for livestock-focused agriculture.

The receptors that could be impacted due to groundwater abstraction or groundwater quality deterioration are the livestock and occupants on the farms within the study area.

Acceptable levels of change in terms of geohydrology conditions would generally be characterised by small to negligible changes in water table depth up until depth of historic boreholes and small changes in chemistry such that there is no level of deterioration in groundwater quality.

Map 16-2 and Map 16-3 present existing boreholes used for livestock and drinking water on and around the study area with detailed views of the Kudu Solar Facility 7 superimposed on a 1:50 000 topo-cadastral map and aerial image respectively.

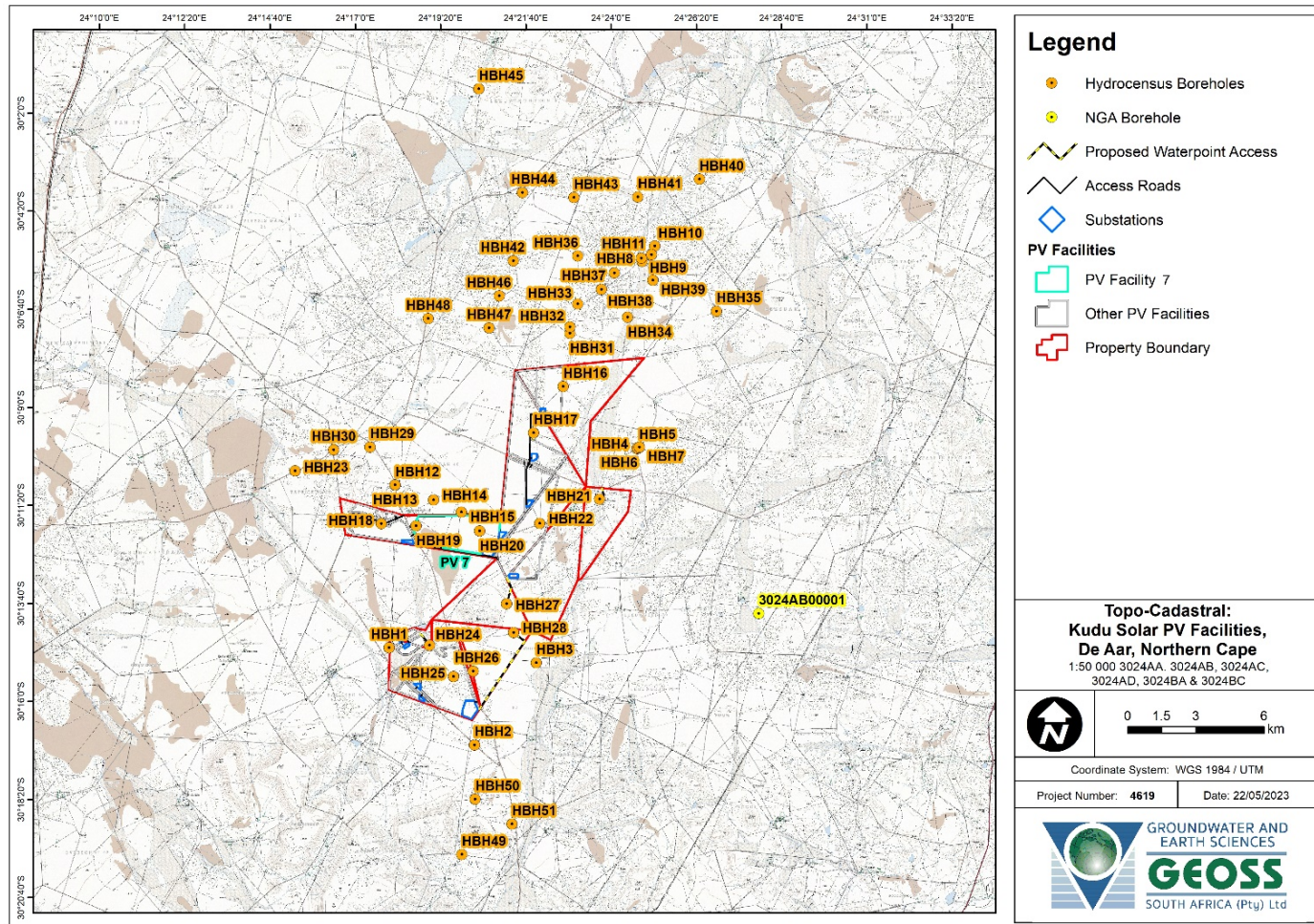

Map 16-2: The study area delineating the study area for the 12 Kudu Solar Facilities, property boundaries, hydrocensus boreholes and the NGA borehole on a 1:50 000 scale topocadastral map (3024AA, 3024AB, 3024AC, 3024AD, 3024BA, 3024BC). Note that this report is focused on Kudu Solar Facility 7.

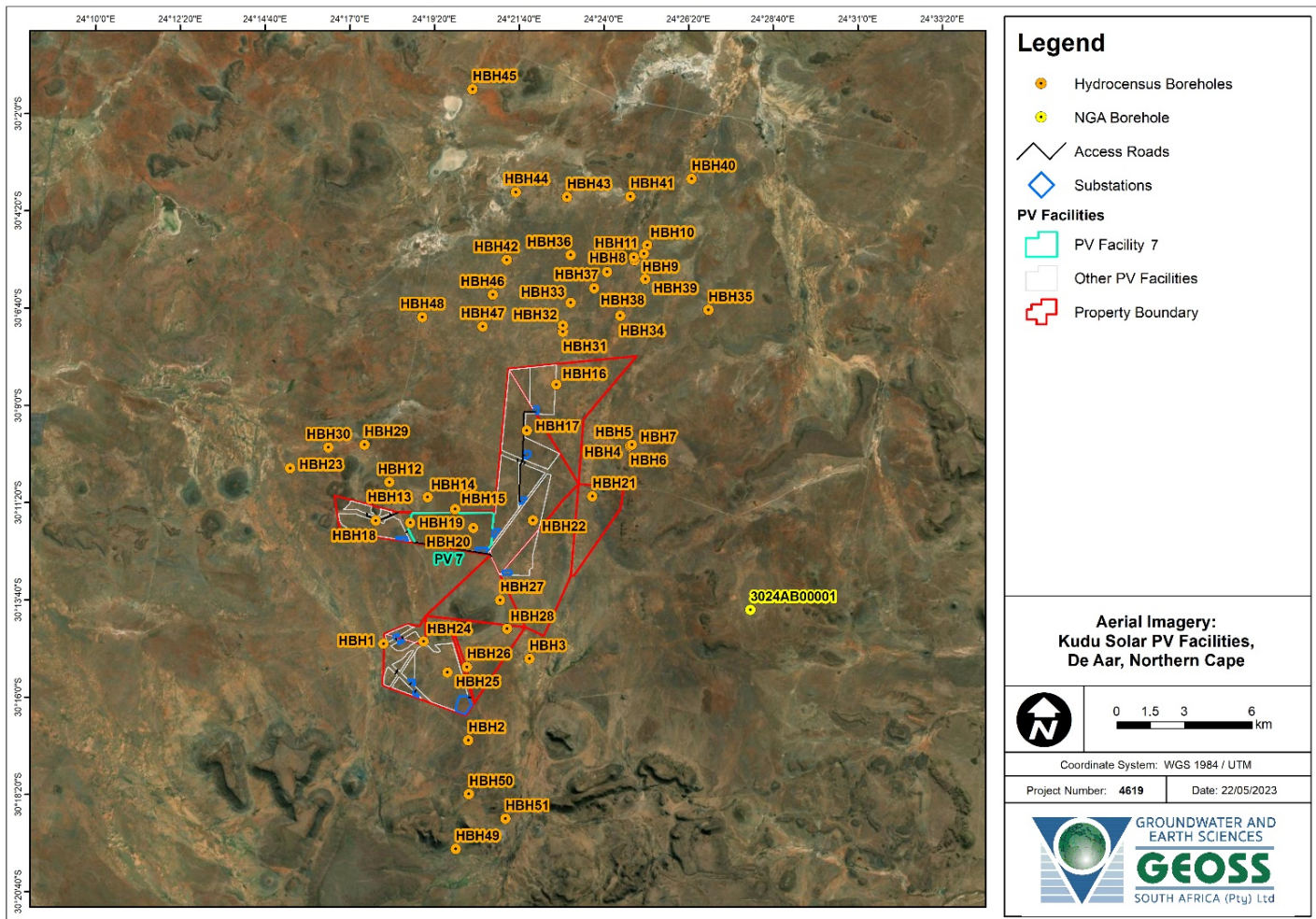

Map 16-3: Aerial view delineating the study area of the 12 Kudu Solar Facilities, hydrocensus boreholes and the NGA borehole. Note that this report is focused on Kudu Solar Facility 7.

16.4.3 Project Specific Description

16.4.3.1 Climate

The study area experiences a semi-arid climate, with most of the rainfall occurring during February to March. Figure 16-1 shows the monthly average minimum and maximum air temperature distribution and Figure 16-2 shows the monthly median rainfall and evaporation distribution for the study area (Schulze, 2009). The long term (1950 – 2000) mean annual precipitation for the study area is 281 mm/a. The rainfall does not exceed evaporation during the course of the year.

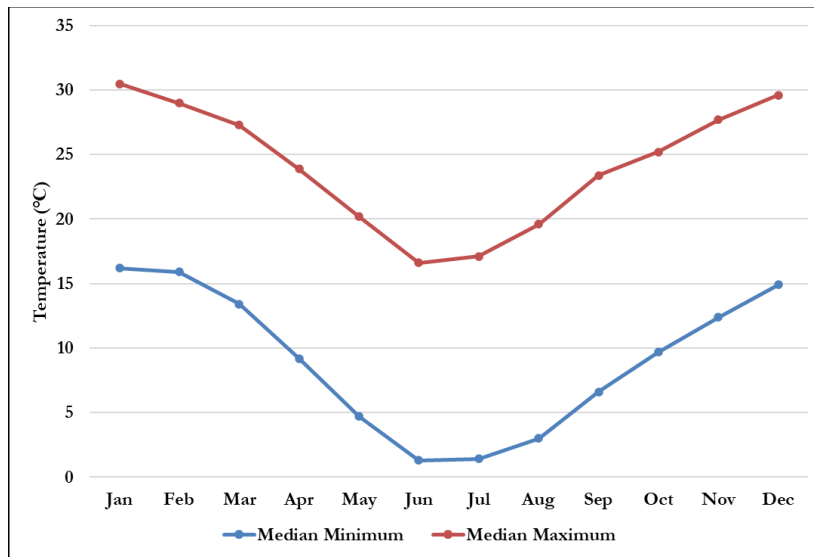

Figure 16-1: Monthly average air temperature for the Kudu Solar Facility study area (Schulze, 2009).

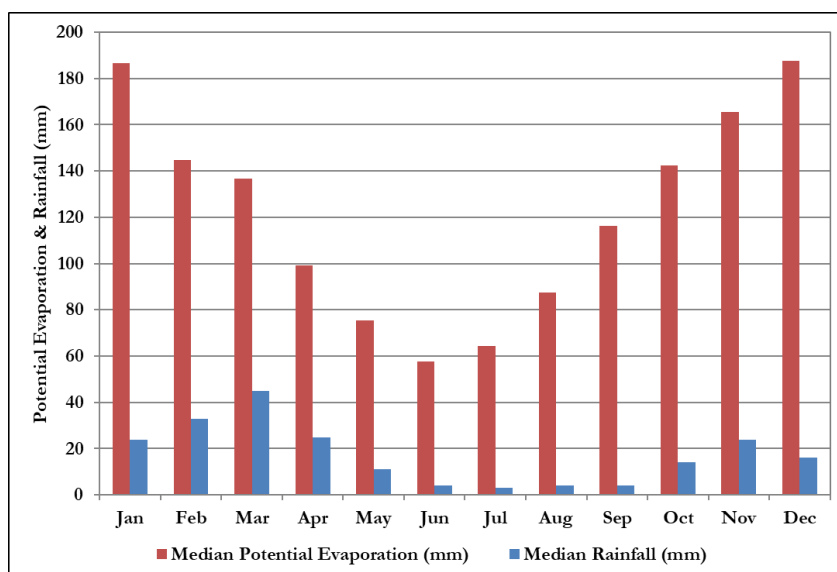



Figure 16-2: Monthly median rainfall and evaporation distribution for the Kudu Solar Facility study area (Schulze, 2009).

16.4.3.2 Regional Geology

The Geological Survey of South Africa (now the Council for Geoscience) has mapped the area at 1:250 000 scale (3024, Colesberg). The geological setting is shown in Map 16-4. The main geology of the area is listed in Table 16-2.

Table 16-2: Geological formations within the study area listed in order of relative age.

Symbol	Formation/Subgroup	Group	Lithology
	Quaternary Deposit		Alluvium / Terrace Gravel
Qc			Calcrete
Jd	Jurassic Intrusion		Dolerite
Pa	Adelaide Subgroup	Beaufort Group	Blue-grey silty mudstone, subordinate brownish-red mudstone; sandstone
Pt	Tierberg Formation	Ecca Group	Blue-grey to black shale with carbonate-rich concretions; subordinate siltstone and sandstone in upper part

The Kudu Solar Facility 7 is mainly underlain by well-developed Quaternary aged calcretes. These quaternary deposits, in turn, overly either dolerite sills and dykes, (Jd) or undifferentiated sediments of the Adelaide Subgroup (Pa) and/or Tierberg Formation (Pt). The Adelaide Subgroup (Pa) comprises interbedded mudstones, siltstones and sandstone, whilst the Tierberg Formation (Pt) consists primarily of shale and sandstone. Both of these units were deposited within a braided river to deltaic setting within the Karoo basin during the Permian Period some 268 to 247 Million years ago (Johnson et al., 2006). These sediments were subsequently intruded during the Jurassic Period by dolerite sills and dykes of the Karoo Dolerite Suite. There are no known large structural geological features in the surrounding area of the proposed project; however, the dolerite sills in the area commonly show extensive jointing as a result of cooling and exhumation (Senger et al., 2015).

16.4.3.3 Regional Hydrogeology

The regional aquifer directly underlying the proposed project study area is classified by the Department of Water Affairs and Forestry (DWAf) (DWAf, 2005) as a fractured aquifer with an average yield potential of 0.5 – 2.0 L/s (Map 16-5). A fractured aquifer describes an aquifer where groundwater only occurs in narrow fractures within the bedrock. However, based on the geological map and the site-specific information it is known that the Quaternary deposits of alluvium and calcrete form an intergranular aquifer on top of the fractured bedrock. There is no known information about this aquifer. An intergranular aquifer is a primary aquifer and is described as an aquifer in which groundwater is stored within, and flows through open pore spaces in the unconsolidated Quaternary deposits.

Based on the DWAf (2005) mapping of the regional groundwater quality, as indicated by electrical conductivity (EC), the groundwater underlying the Kudu Solar Facility and the surrounding area is in the range of 70 – 300 mS/m. This is considered to be “good to marginal” quality for water (Map 16-6) with respect to drinking water standards.

Both these classifications are based on regional datasets, and therefore only provide an indication of conditions to be expected.

According to research done by Harkness et al. (2018), there is evidence in the southern portion of the Karoo basin that there are several variable aged sources of ground water at different depths. They found that the deeper groundwater was typically more saline, older according to isotope data, and had chemical signatures indicating both ancient meteoric and marine sources. Although separated by confining fine grained units throughout, fracture and joint sets within dolerite sills and dykes potentially act as a conduit for mixing between younger freshwater, and ancient saline aquifers.

16.4.3.4 Aquifer Vulnerability (DRASTIC)

Based on the regional datasets the proposed project overlies a fractured aquifer that possesses water bearing properties due to fracturing. Several methods have been developed to classify an aquifer's vulnerability with The DRASTIC method being applied to this study.

Groundwater vulnerability can be defined as the "tendency for contaminants to reach a specified position in the groundwater system after introduction at some location" (Vrba and Zaporozec, 1994). Key physical parameters which determine groundwater vulnerability include lithology, thickness, effective porosity, groundwater flow direction, age and residence time of water. Generally, the residence time of contaminants in groundwater and the distance that it travels in the aquifer are considered important measures of vulnerability.

There are two main groups of methods for assessing groundwater vulnerability, namely:

- Index or subjective rating methods, and
- Statistical or process-based methods.

The "index or subjective rating method" is relatively easily addressed within a GIS framework. The cell-based layer approach facilitates the assignment of ratings and weights, and rapid achievement of a final result of relative groundwater vulnerability. This approach also means that the algorithm can easily be repeated as new or more detailed data sets are obtained or if ratings and weightings need to be adjusted as a result of a sensitivity analysis for example. The most well-known "index or subjective rating method" is the "DRASTIC" method (Aller et al., 1987). The DRASTIC method of Aller et al. (1987) uses the typical overlay technique often applied in subjective rating methods. The DRASTIC approach is based on four major assumptions:

- The contaminant is introduced at ground surface;
- The contaminant is flushed into the groundwater by precipitation;
- The contaminant has the mobility of water; and
- The area evaluated using DRASTIC is 40.5 ha or larger.

The implication of these assumptions is that DRASTIC should not be used for contaminants that do not have the mobility of water or for point assessment (such as storage tanks). In addition, groundwater conditions in South Africa are dominated by secondary/fracture-controlled flow conditions. The DRASTIC method does not consider local preferential flow paths of fractured aquifer systems particularly well. The DRASTIC method takes into account the following factors:

D	=	depth to groundwater	(9)
R	=	recharge	(8)
A	=	aquifer media	(8)
S	=	soil type	(4-5)
T	=	topography	(10)
I	=	impact of the vadose zone	(9)
C	=	conductivity (hydraulic)	(6)

The number indicated in parenthesis at the end of each factor description is the weighting or relative importance at that factor.

Groundwater vulnerability maps developed using the DRASTIC method have been produced in many parts of the world. In spite of the widespread use of DRASTIC, the effectiveness of the method has been met with mixed success due to hydrogeological heterogeneity and the many assumptions that need to be made in determining groundwater vulnerability. In addition, the use of a generic vulnerability map only gives a broad indication of relative vulnerability and in many instances detailed scale, contaminant specific vulnerability assessments are required.

As part of the Groundwater Resources Assessment Project (DWAF, 2005), numerous data sets were produced and this enabled the mapping of groundwater vulnerability at the national scale on a 1 km by 1 km cell (pixel) size basis (Conrad and Munch, 2007). This national scale map indicates the relative vulnerability of groundwater resources throughout the country and provides project planners a clear idea of what level of groundwater protection is required.

The groundwater vulnerability for the study area is shown in Map 16-7. The development area for the Kudu Solar Facility 7 has a **Low to Medium** groundwater vulnerability. It is assumed that the regional data maps relate to the underlying fractured aquifer and not the intergranular aquifer. The intergranular aquifer on top of the fractured aquifer has no protection and therefore any contamination that is introduced on the surface of the intergranular aquifer will infiltrate into the subsurface and can cause contamination of the intergranular aquifer. Therefore, the vulnerability specifically for the intergranular aquifer is considered to be **medium**.

16.4.4 Site Specific and Existing Groundwater Information

16.4.4.1 NGA Database

A desktop assessment was initially carried out within and around the study area to determine if there were any groundwater users in the area. The NGA database provides data on borehole positions, groundwater chemistry and yield, where available. The NGA indicated there is one borehole surrounding the study area (Map 16-2 and Map 16-3). The NGA site is summarized in Table 16-3.

Table 16-3: Summary of NGA borehole.

NGA Label	Latitude (DD, WGS84)	Longitude (DD, WGS84)	Yield (L/s)	Depth (m)	Lithology
3024AB00001	-30.23333	24.46667	0.18	0-39.93 39.93-73.46	Shale Sandstone

The NGA site indicates a borehole has a yield of 0.18 L/s, depth of 73.46 m with a lithology of shale followed by sandstone.

16.4.4.2 Hydrocensus

A representative hydrocensus was conducted on 23 and 24 March 2022 on the farm portions on which the Kudu Solar Facilities 1 - 12 are located (i.e. the study area) and the surrounding farm portions. The hydrocensus boreholes are shown on Map 16-2 and Map 16-3. These boreholes are summarised in Table 16-4. During the hydrocensus data such as borehole depth, water level (WL), pH, total dissolved solids (TDS) and EC were measured.

Table 16-4 : Summary of Boreholes in the study area.

Borehole Name	Latitude (DD, WGS84)	Longitude (DD, WGS84)	pH	EC (mS/m)	TDS (mg/L)	WL (mbgl)	Depth (m)
HBH1	-30.2463968	24.2971598	7.4	76	370	-	-
HBH2	-30.2851593	24.3358956	-	-	-	-	-
HBH3	-30.2526869	24.3643247	7.5	91	440	17.75	-
HBH4	-30.1679489	24.4109898	7.1	102	500	8.7	-
HBH5	-30.1675761	24.4118524	-	-	-	8.7	-
HBH6	-30.1676747	24.4112416	-	-	-	-	-
HBH7	-30.1673778	24.4120952	7.5	95	460	9.2	-
HBH8	-30.0936932	24.4136653	6.8	126	1260	6.4	10
HBH9	-30.092446	24.413403	7.5	104	510	8.4	-
HBH10	-30.0875905	24.4194914	7.3	80	390	-	-
HBH11	-30.091018	24.4180866	-	-	-	8.1	-
HBH12	-30.1818617	24.3003232	7.5	94	460	10.1	-
HBH13	-30.181802	24.3002685	-	-	-	-	-
HBH14	-30.1879078	24.3179014	-	-	-	-	-
HBH15	-30.1927376	24.3305225	-	-	-	-	-
HBH16	-30.1431559	24.377371	7.4	100	490	11	-
HBH17	-30.1614565	24.3636659	9.1	64	310	7.25	17
HBH18	-30.1971676	24.2939657	8.4	107	520	11.1	-
HBH19	-30.1980902	24.3098031	7.5	86	420	10.95	-
HBH20	-30.200251	24.33882	9.6	104	520	-	-
HBH21	-30.187906	24.393707	8	58	270	-	-
HBH22	-30.197459	24.366364	7.7	57	280	-	-

Borehole Name	Latitude (DD, WGS84)	Longitude (DD, WGS84)	pH	EC (mS/m)	TDS (mg/L)	WL (mbgl)	Depth (m)
*HBH23	-30.175992	24.2547534	-	-	-	-	-
*HBH24	-30.245532	24.315637	-	-	-	-	-
*HBH25	-30.258001	24.326557	-	-	-	-	-
*HBH26	-30.255856	24.335565	-	-	-	-	-
*HBH27	-30.229251	24.35097	-	-	-	-	-
*HBH28	-30.240724	24.35404	-	-	-	-	-
*HBH29	-30.166797	24.288983	-	-	-	-	-
*HBH30	-30.167743	24.272326	-	-	-	-	-
*HBH31	-30.122051	24.380559	-	-	-	-	-
*HBH32	-30.119526	24.380652	-	-	-	-	-
*HBH33	-30.110477	24.384284	-	-	-	-	-
*HBH34	-30.115827	24.406987	-	-	-	-	-
*HBH35	-30.113626	24.447559	-	-	-	-	-
*HBH36	-30.09143	24.384297	-	-	-	-	-
*HBH37	-30.098216	24.401043	-	-	-	-	-
*HBH38	-30.104676	24.395147	-	-	-	-	-
*HBH39	-30.101161	24.418577	-	-	-	-	-
*HBH40	-30.061157	24.440153	-	-	-	-	-
*HBH41	-30.068085	24.411932	-	-	-	-	-
*HBH42	-30.093241	24.354924	-	-	-	-	-
*HBH43	-30.068237	24.382791	-	-	-	-	-
*HBH44	-30.06616	24.359238	-	-	-	-	-
*HBH45	-30.024899	24.339597	-	-	-	-	-
*HBH46	-30.107118	24.348457	-	-	-	-	-
*HBH47	-30.119755	24.343665	-	-	-	-	-
*HBH48	-30.115915	24.315975	-	-	-	-	-
*HBH49	-30.328537	24.329885	-	-	-	-	-
*HBH50	-30.306722	24.336103	-	-	-	-	-
*HBH51	-30.316574	24.352879	-	-	-	-	-

* Could not gain access to borehole due to wet conditions. Farmer indicated location of borehole on a map.

- Data could not be obtained due to base plate that covered the whole borehole or the information was unavailable.

From the information obtained during the hydrocensus it is clear that the boreholes are shallow in the area as all of them were wind pumps. The water is mainly used for domestic use and livestock watering. The boreholes had an EC that ranged from 57 mS/m to 126 mS/m and all of the boreholes were only drilled into the alluvium as the farmers reported that they only drill until they intersect the “ysterklip” which can be assumed to be the shales or dolerites underlying the alluvium.

16.4.4.3 Groundwater Quality

The groundwater quality obtained during the hydrocensus was assessed to establish if it is suitable for the following uses:

- Potable water
- Domestic use which will include washing of dishes and toilet flushing
- Washing of panels
- General construction and concrete batching

16.4.4.3.1 SANS241-1:2015: Drinking water standards

The field parameters that were obtained from boreholes that were tested during the hydrocensus have been classified according to the South African National Standard (SANS) SANS241-1: 2015 standards for domestic water in (Table 16-5). Table 16-6 presents the field chemistry results, colour coded according to the SANS241-1: 2015 drinking water assessment standards.

Table 16-5: Classification table for specific limits for domestic water standards

Acute Health	Chronic Health	Aesthetic	Operational	Acceptable
---------------------	-----------------------	------------------	--------------------	-------------------

The limits and associated risks for domestic water as determined by the SANS 241:2015 are as follows, where:

- Health risks: parameters falling outside these limits may cause acute or chronic health problems in individuals.
- Aesthetic risks: parameters falling outside these limits indicate that water is visually, aromatically or palatably unacceptable.
- Operational risks: parameters falling outside these limits may indicate that operational procedures to ensure water quality standards are met may have failed.

Table 16-6: Production borehole results classified according the SANS241-1:2015

	Borehole Name	pH	EC (mS/m)	TDS (mg/L)
	HBH1	7.4	76	370
	HBH3	7.5	91	440
	HBH4	7.1	102	500
	HBH7	7.5	95	460
	HBH8	6.8	126	1260
	HBH9	7.5	104	510
	HBH10	7.3	80	390
	HBH12	7.5	94	460
	HBH16	7.4	100	490
	HBH17	9.1	64	310

	Borehole Name	pH	EC (mS/m)	TDS (mg/L)
	HBH18	8.4	107	520
	HBH19	7.5	86	420
	HBH20	9.6	104	520
	HBH21	8	58	270
	HBH22	7.7	57	280
SANS241- 1:2015		5-9.5	≤170 Aesthetic	≤1200 Aesthetic

16.4.4.3.2 DWA (1998): Drinking Water Assessment Guide

The field parameters that were obtained have also been classified according to the DWAF (1998) standards for domestic water (as they are a little easier to understand). Table 16-7 enables an evaluation of the water quality with regards to the various parameters measured (DWAF, 1998). Table 16-8 presents the water chemistry analysis results colour coded according to the DWAF drinking water assessment standards.

Table 16-7: Classification table for the groundwater results (DWAF, 1998)

Blue	(Class 0)	Ideal water quality - suitable for lifetime use.
Green	(Class I)	Good water quality - suitable for use, rare instances of negative effects.
Yellow	(Class II)	Marginal water quality - conditionally acceptable. Negative effects may occur.
Red	(Class III)	Poor water quality - unsuitable for use without treatment. Chronic effects may occur.
Purple	(Class IV)	Dangerous water quality - totally unsuitable for use. Acute effects may occur.

Table 16-8: Classified production borehole results according to DWAF 1998.

	Borehole Name	pH	EC (mS/m)	TDS (mg/L)
	HBH1	7.4	76	370
	HBH3	7.5	91	440
	HBH4	7.1	102	500
	HBH7	7.5	95	460
	HBH8	6.8	126	1260
	HBH9	7.5	104	510
	HBH10	7.3	80	390
	HBH12	7.5	94	460
	HBH16	7.4	100	490
	HBH17	9.1	64	310

	Borehole Name	pH	EC (mS/m)	TDS (mg/L)
	HBH18	8.4	107	520
	HBH19	7.5	86	420
	HBH20	9.6	104	520
	HBH21	8	58	270
	HBH22	7.7	57	280
DWAf (1998) Drinking Water Assessment Guide	Class 0	5-9.5	<70	<450
	Class I	4.5-5&9.5-10	70-150	450-1000
	Class II	4-4.5&10-10.5	150-370	1000-2400
	Class III	3-4&10.5-11	370-520	2400-3400
	Class IV	<3&>11	>520	>3400

The available chemistry results (pH, EC and TDS) have been compared SANS241-1: 2015 standards and the DWAf (1998) standards in Table 16-6 and Table 16-8. From this it is seen that the groundwater quality is generally of good quality in terms of pH, EC and TDS. It is possible that the groundwater can be used for potable and domestic purposes with only minor treatment however a full laboratory analysis will be required.

With regards to the cleaning of panels it is understood that a very clean water is required to clean the panels otherwise salts will deposit on the panels. The electric conductivity for the groundwater ranges from 57 to 126 mS/m which is considered to be good to marginal. Although this water quality is relatively good it will not be suitable for panel washing as it will result in salts precipitating on the panels. The salts could be removed from the groundwater by thermal distillation (i.e. boiling since salt has a much higher boiling point than water) or by membrane separation (commonly reverse osmosis). Both of these techniques are possible but financial viability would have to be determined before commissioning as both techniques are costly on a large scale.

In terms of using groundwater for construction purposes and mixing of concrete the SANS 51008:2006 (*Mixing water for concrete document*) was referred to. Both the composition of the water and the application of the concrete needs to be considered. Potable water is considered to be suitable for concrete batching with no testing required. Groundwater is also considered to potentially be suitable for concrete batching; however, it requires testing as some groundwater can be very saline which is not considered to be suitable. Furthermore, the SANS 51008 standards do specify maximum limits for chlorides, sulphates, alkalinity, phosphates, nitrates, lead and zinc. Most of these parameters are currently unknown and therefore it is unclear if the groundwater is suitable for construction and concrete batching.

16.4.4.4 Water level elevation maps

The water level elevations obtained during the hydrocensus were interpolated² to determine the groundwater flow direction. The data is presented in Figure 16-3, and indicates a 99.44% correlation between surface topography (elevation (mamsl)) and groundwater level elevation. Bayesian interpolation is therefore considered an acceptable interpolation technique. The water level elevation map for March 2022 is presented in Map 16-8. From this it is seen that the groundwater flow direction is in a general north westerly direction.

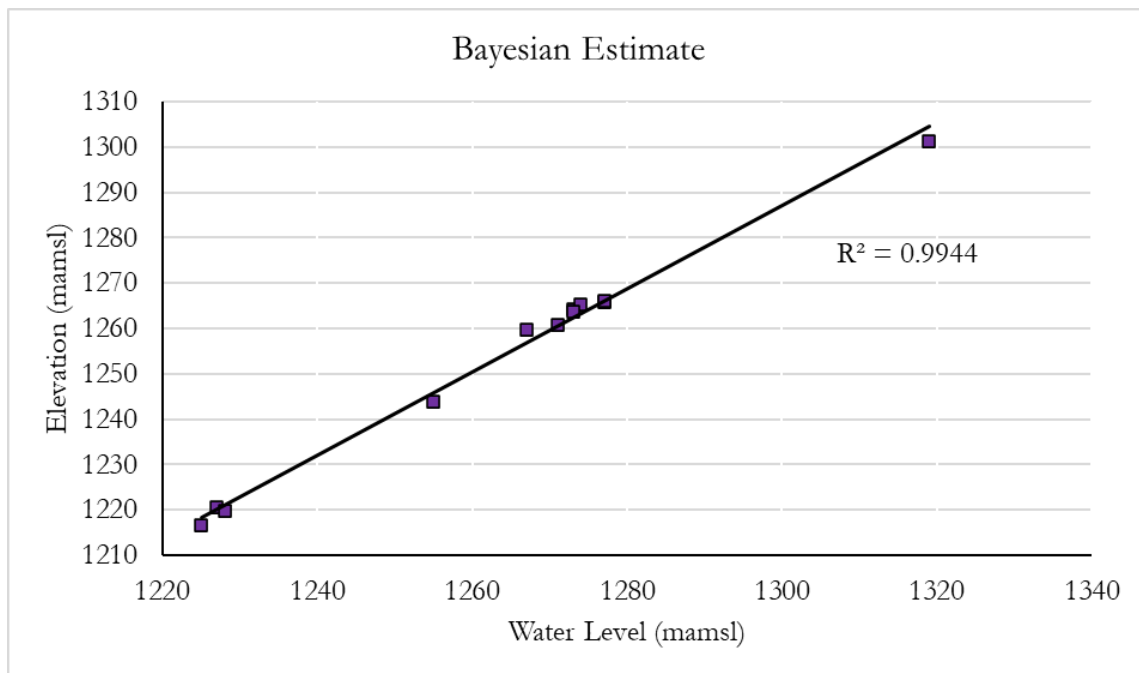
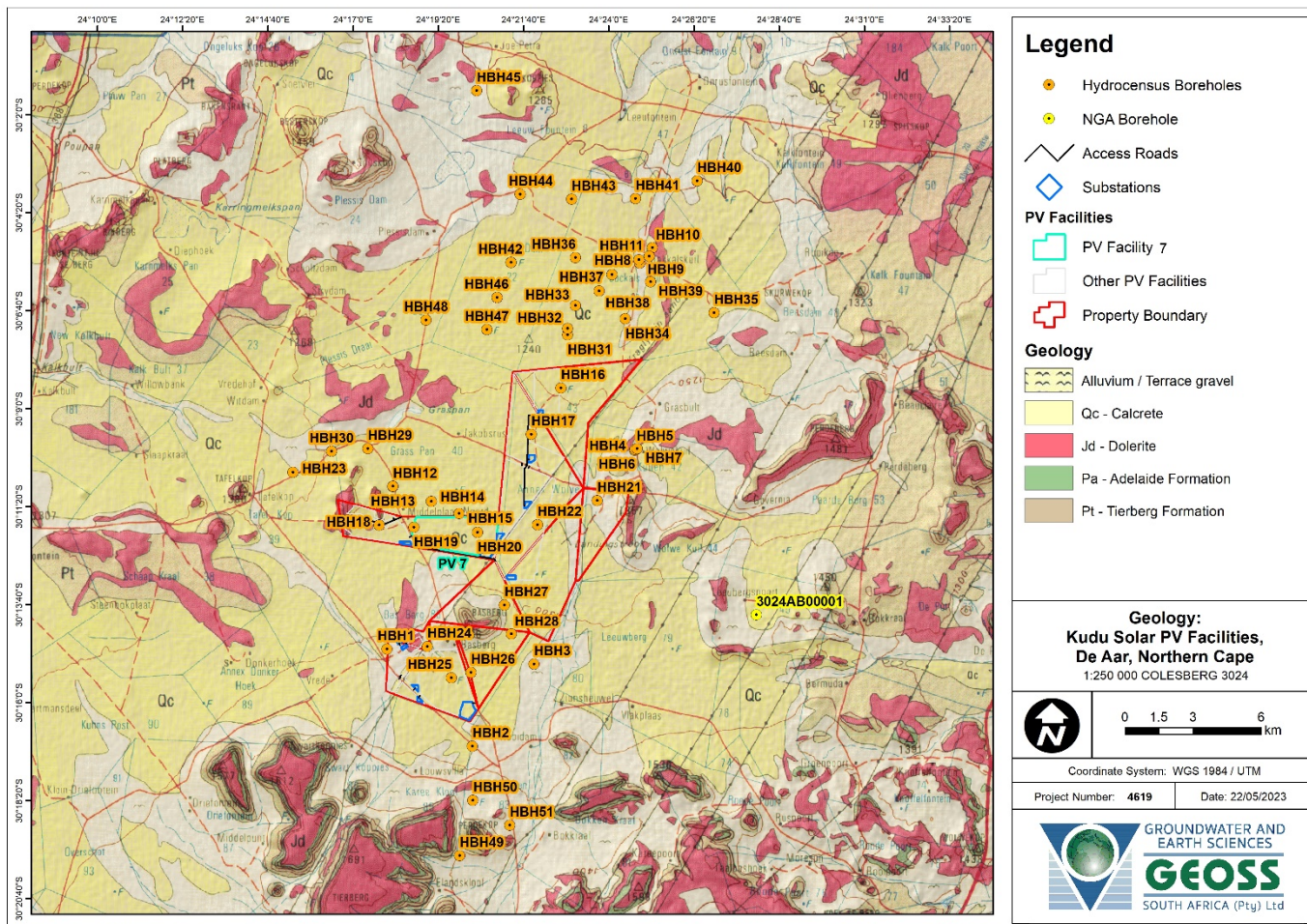
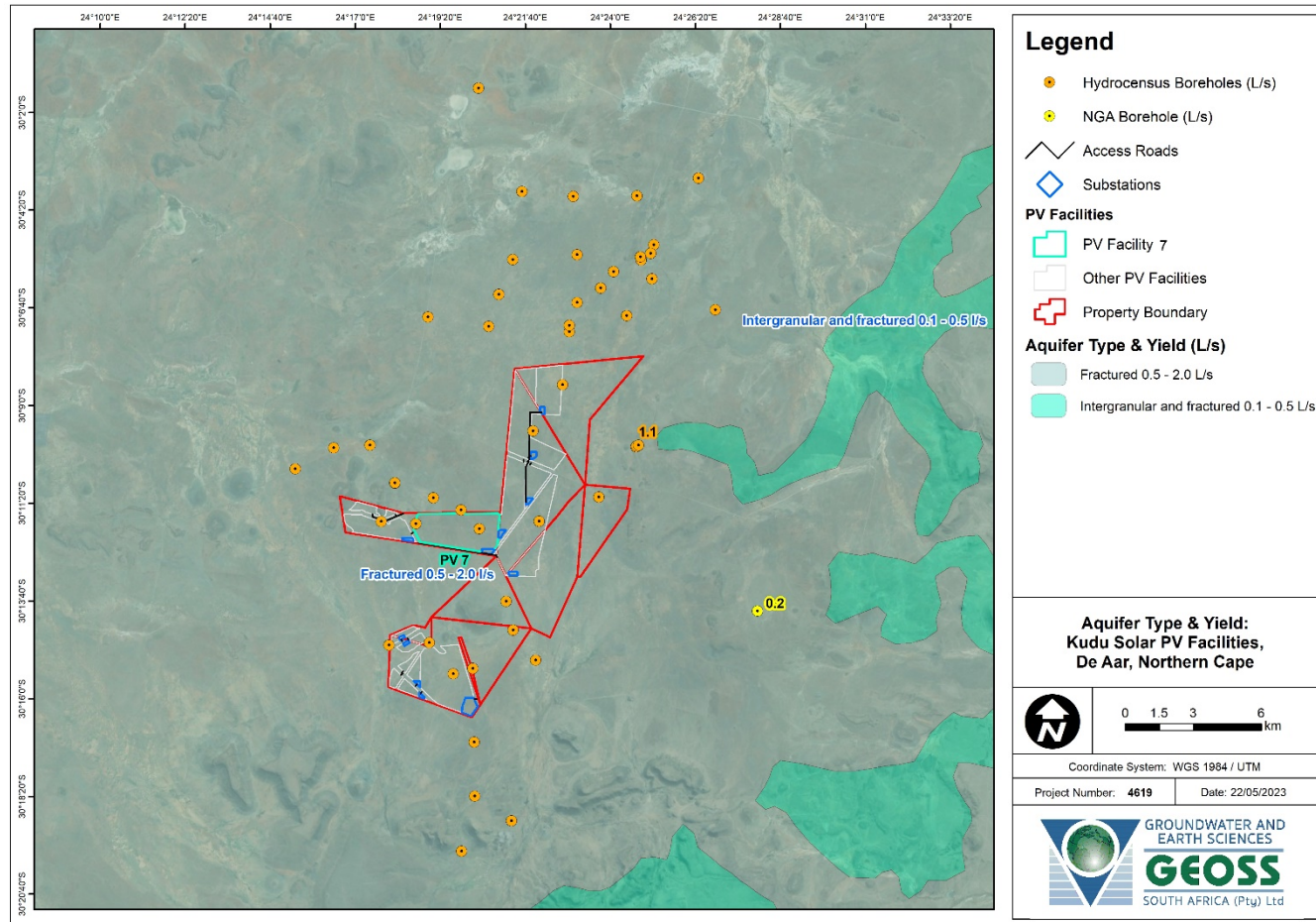

Figure 16-3: Correlation between surface topography and groundwater elevation.

² Bayesian interpolation was used and the output generated was a point grid, which was interpolated in ArcGIS software to create the groundwater elevation surface.



Map 16-4: Geological setting of the study area for the Kudu Solar Facilities. (CGS (1997) map: 1:250 000 scale Colesberg). Note that this report is focused on Kudu Solar Facility 7.



Map 16-5: Regional aquifer yield (DWAf, 2005) and borehole yields (L/s) in the study area for the Kudu Solar Facilities. Note that this report is focused on Kudu Solar Facility 7.

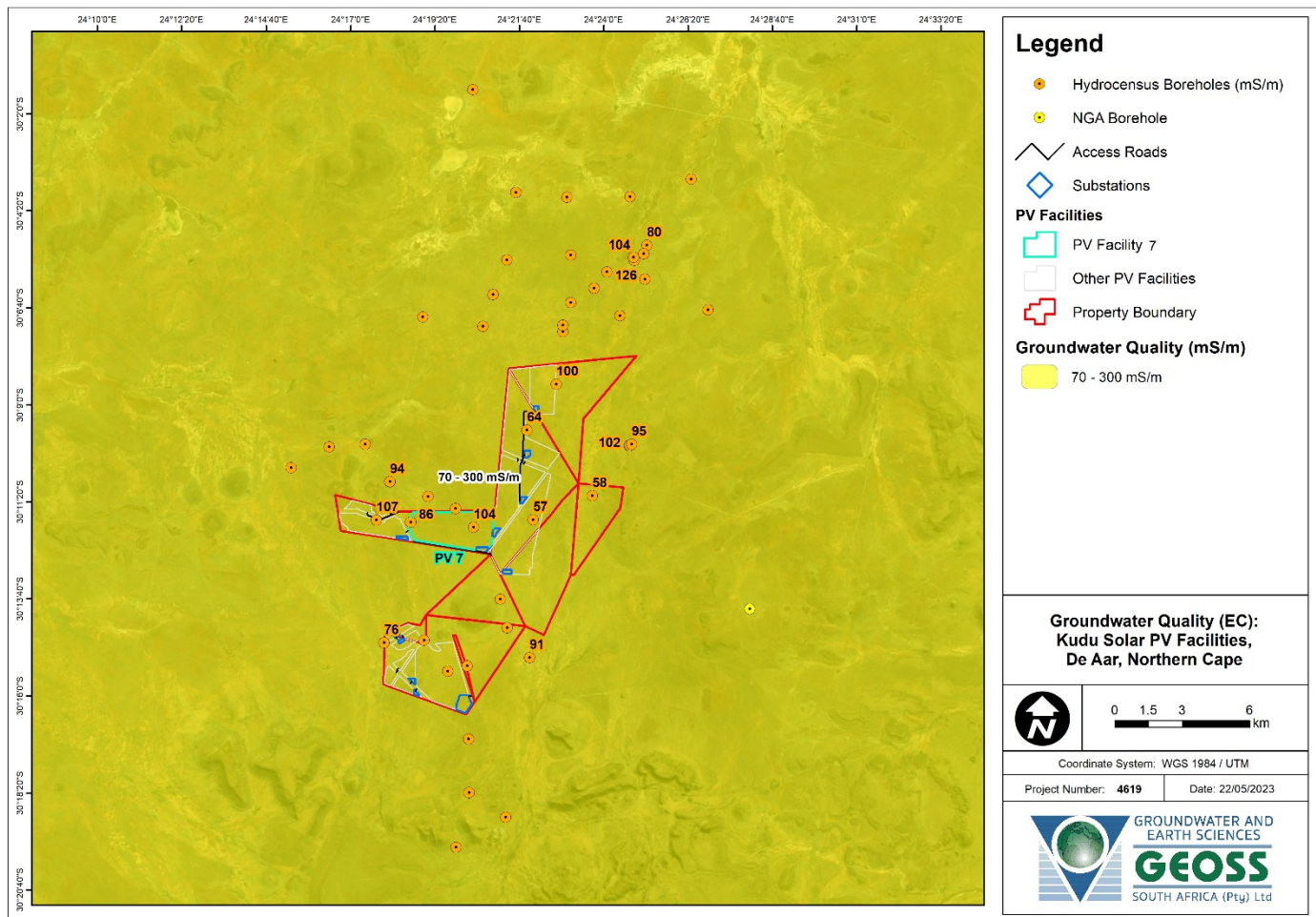

Map 16-6: Regional groundwater quality (mS/m) from DWAF (2005) and borehole groundwater quality (EC in mS/m) in the study area for the Kudu Solar Facilities. Note that this report is focused on Kudu Solar Facility 7.

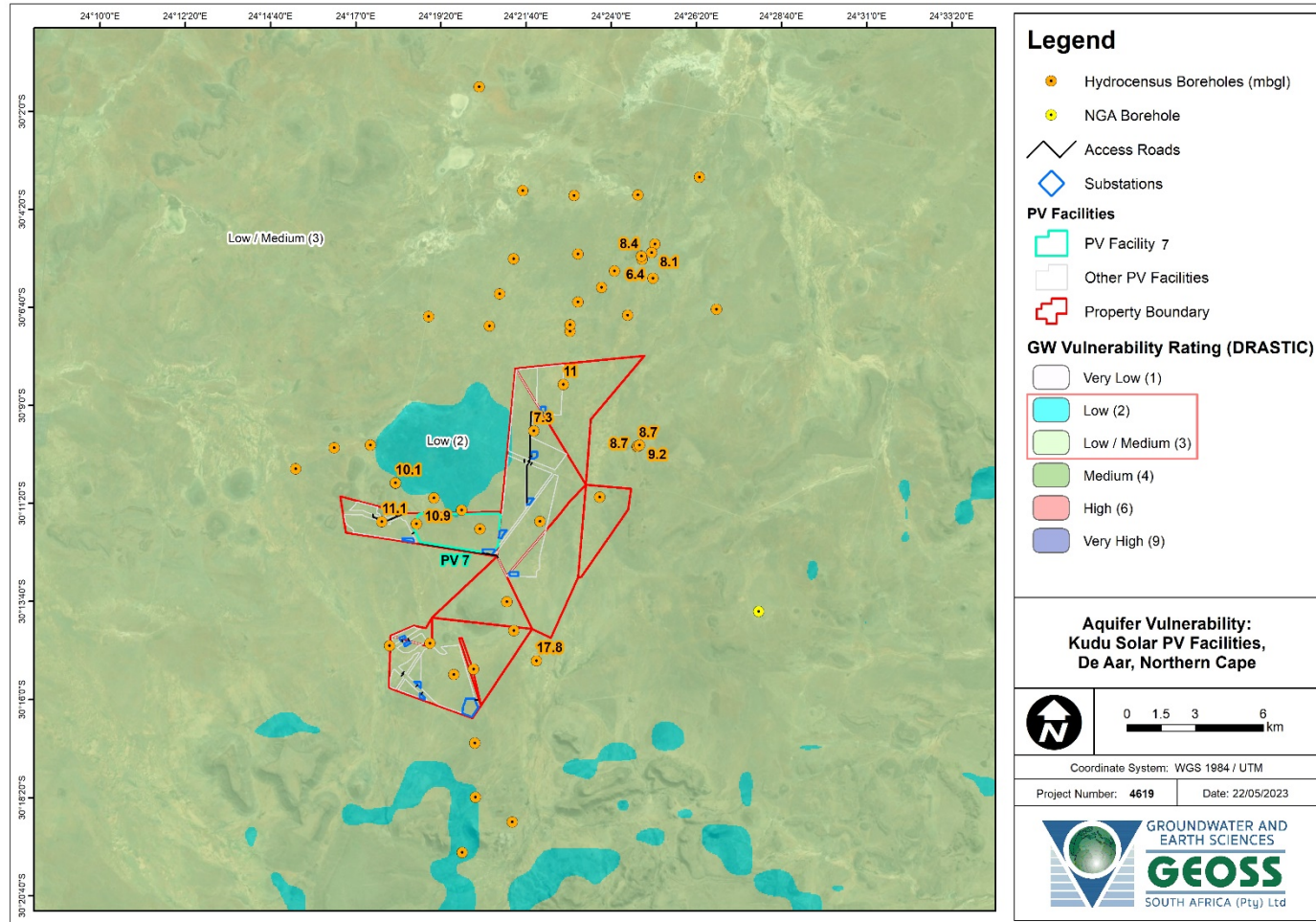

Map 16-7: Vulnerability rating (DWAf, 2005) and groundwater depths (mbgl) in the study area for the Kudu Solar Facilities. Note that this report is focused on Kudu Solar Facility 7.

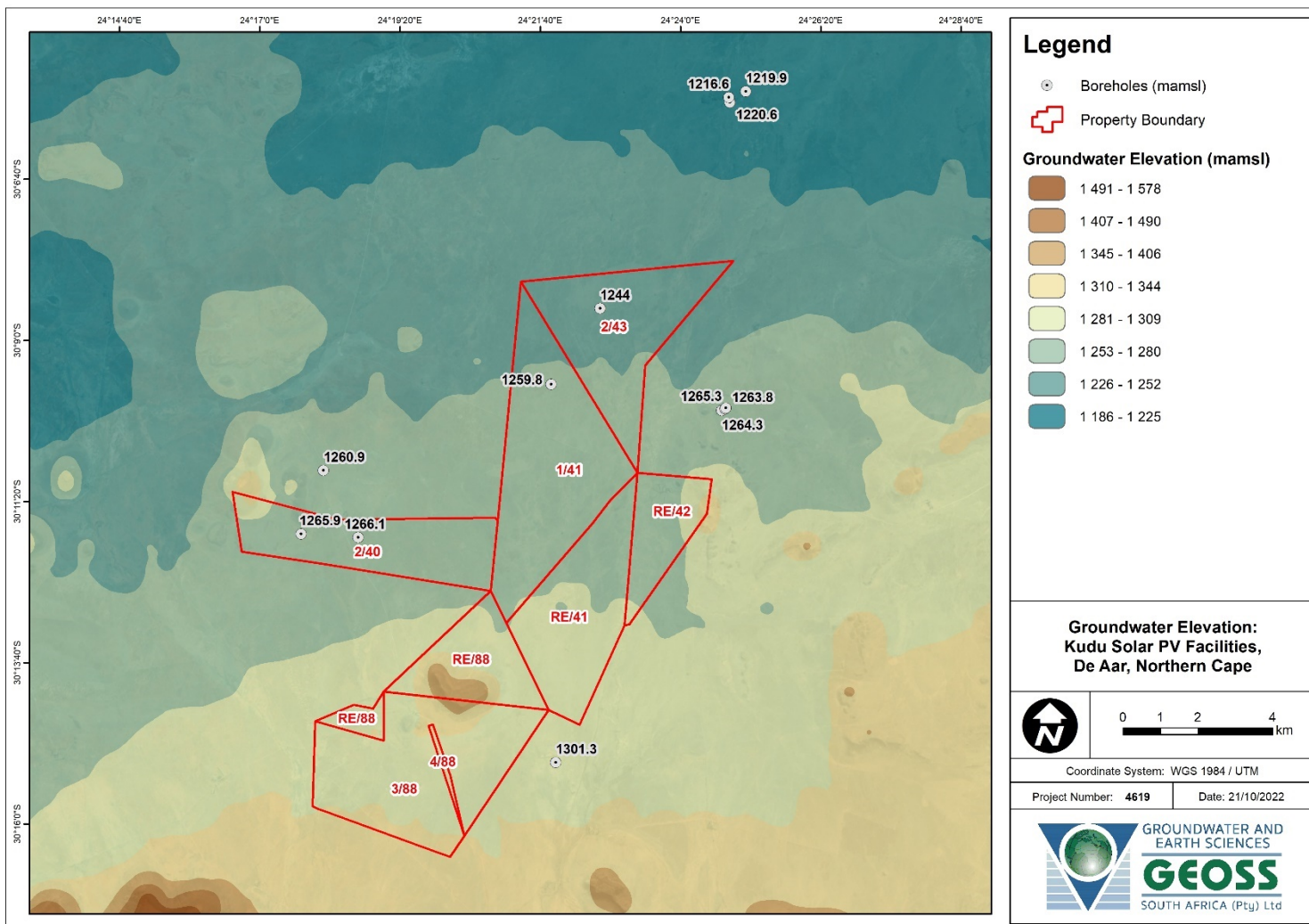

Map 16-8: Groundwater contour map based on the March 2022 field measurements in the study area. Note that this report is focused on Kudu Solar Facility 7.

16.4.5 Identification of Environmental Sensitivities

16.4.5.1 Sensitivities identified by the National Web-Based Environmental Screening Tool

Part of the terms of reference for the Kudu Solar Facility was to identify sensitivities by the National Web-Based Environmental Screening Tool. However, it is important to note that there are no dedicated Geohydrology or Groundwater themes on the National Web-based Environmental Screening Tool (Screening Tool) (as of May 2023), therefore the environmental sensitivity of the proposed project area as identified by the Screening Tool is not applicable. As such, no site sensitivity verification report is required. Furthermore, there is no dedicated assessment protocol prescribed for Geohydrology or Groundwater. Therefore, the specialist assessment has been undertaken in compliance with Appendix 6 of the NEMA EIA Regulations of 2014.

16.4.5.2 Specialist Sensitivity Analysis and Verification

As there is no sensitivity assessment protocol for Groundwater or Geohydrology, the following sensitivity analysis is based primarily on the results from the DRASTIC approach outlined in section 16.4.2. From this analysis a geospatial model was created, which shows that the entire site sits within a low/medium ground water vulnerability rating, with the overlying alluvium being tentatively given a medium vulnerability rating. Furthermore, the site is situated above a fractured aquifer with relatively low yield of 0.5 to 2.0 l/s. Overlying the fractured aquifer is an intergranular aquifer made up of Cenozoic alluvium and carbonate palaeosols. This aquifer has no protection, with the result that any contamination introduced on the surface can infiltrate into the subsurface and potentially contaminate this aquifer. However, this is coupled with a low permeability of the unsaturated layer, which allows for a significant attenuation capacity. The sensitivity across the entire development is, therefore, similarly classified as “medium” with respect to all activities associated with the proposed development. This classification as “medium” sensitivity does not represent a constraint and does not represent an area to be avoided from a groundwater sensitivity perspective. Accordingly, no buffer areas have been identified save for a 50m buffer around borehole sites with respect to BESS construction/installation. Additional information on the impacts associated with the BESS are discussed in the following sections. Currently no site alternatives have been identified as these would be located within a similarly classed sensitivity area.

The major receptors with respect to ground water within the region are limited to livestock and the occupants of the surrounding farms. The principal activity within the region is the farming of livestock, which relies almost completely on the underground water resource. Any deterioration in either groundwater quality or groundwater level will negatively impact on these receptors.

16.4.5.3 Sensitivity Analysis Summary Statement

As indicated above, following the identification of sensitivities during the Scoping Phase, the Project Developer considered such sensitivities and formulated the Revised Scoping Buildable Areas. The Revised Scoping Buildable Areas led to the identification of the development footprints and detailed layouts in the EIA Phase. The development footprint and detailed layout are considered suitable from a Geohydrological perspective, as the sensitivities identified above (i.e. BESS placement to be outside of 50 m from identified boreholes) have been taken into consideration. The development footprint and detailed layout are shown in Map 16.9. Changes to the detailed layouts are deemed acceptable if the changes remain within the approved buildable areas / development footprints and area assessed during the Scoping and EIA Process with no-go sensitive areas avoided.

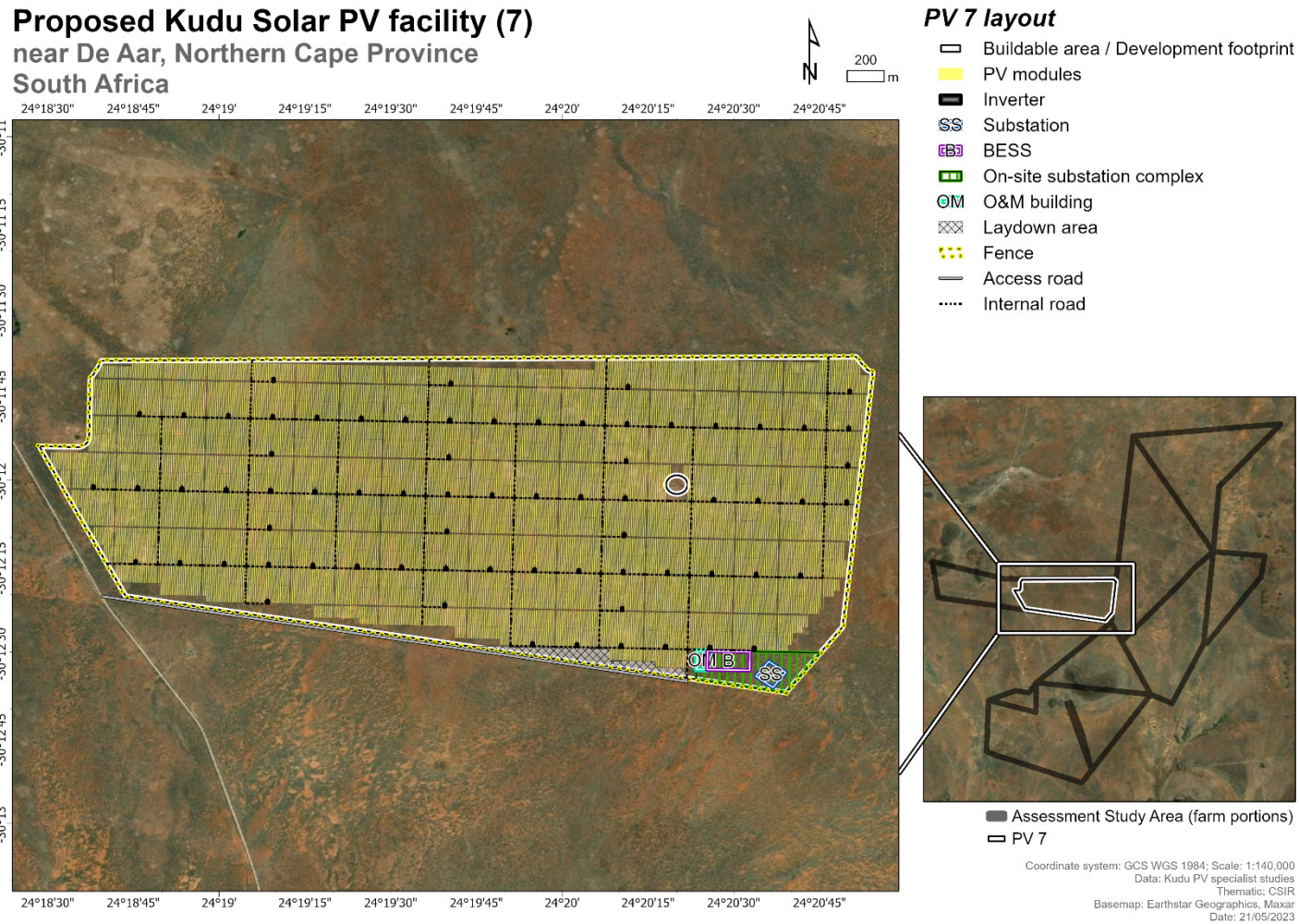

Map 16-9: Detailed Layout of Kudu Solar Facility 7.

16.5 Issues, Risks and Impacts

16.5.1 Identification of Potential Impacts/Risks

The potential impacts on groundwater due to the proposed project activities are listed below:

- Lowering of the groundwater level due to abstraction during the construction and operational phases (18 000 m³/a for the Construction Phase and 2 000 m³/a for the Operational Phase for this PV project).
- Potential impact on groundwater quality as a result of accidental oil spillages or fuel leakages during the construction and decommissioning phases.
- Potential impact on groundwater quality as a result of cleaning agents used for cleaning the solar panels during the operational phase.
- Potential impact on groundwater quality as a result of electrolyte that will be used for the BESS.

Any construction activities such as the excavation and installation of foundations and piling (narrow diameter holes for foundation purposes) will have minimal to no impact on the groundwater of the site or region, as the groundwater level is approximately >5 mbgl.

The potential impacts identified during the Scoping and EIA are:

Construction Phase

- Potential impact 1: Potential lowering of the groundwater level from construction requirements.
- Potential impact 2: Potential impact on groundwater quality as a result of accidental oil spillages or fuel leakages.

Operational Phase

- Potential impact 3: Potential lowering of the groundwater level from operational requirements.
- Potential impact 4: Potential impact on groundwater quality as a result of using cleaning agents for cleaning the solar panels.
- Potential impact 5: Groundwater quality deterioration as a result of electrolyte that will be used for the BESS.

Decommissioning Phase

- Potential impact 6: Potential impact on groundwater quality as a result of accidental oil spillages or fuel leakages.
- Potential impact 7: Potential lowering of the groundwater level from decommissioning requirements.

Although the project description does not state the anticipated water use during decommissioning phase, from previous experience on similar projects it is unlikely that water use for the decommissioning phase will exceed that of the construction phase. This impact is,

therefore, assessed according to anticipated water usages similar to that of the construction phase.

Cumulative Impacts

- Cumulative Impact 1: Potential lowering of groundwater level during the construction, operational and decommissioning phase for all 12 of the Kudu PV facilities.
- Cumulative Impact 2: Potential impact on groundwater quality as a result of accidental oil spillages or fuel leakages from the construction and the decommissioning phase for all 12 Kudu facilities.
- Cumulative Impact 3: Potential of impact on groundwater quality as a result of using cleaning agents for cleaning the solar panels during the operational phase for all the 12 Kudu facilities.
- Cumulative Impact 4: Potential impact on groundwater quality as a result of electrolyte that will be used for the BESS.
- Cumulative Impact 5: Other wind and solar, and EGI projects within a 30 km radius.

No indirect impacts are identified.

16.5.2 Summary of Issues identified during the Public Consultation Phase

The following represents a summary of the main issues identified during the Public Consultation Phase during Scoping. Many of the stakeholders shared the same concerns including:

- Increased abstraction of groundwater due to the proposed development may deplete the groundwater resources in the area.
- Increased abstraction may lower the groundwater table to depths lower than the average windpump depth of 50 to 80 meters.
- Whether the cumulative water requirements are serviceable by the aquifer and does not exceed the potential recharge.
- What the Water Use Licence Requirements are for groundwater uses related to the proposed project.

Table 16-9 shows a more detailed representation of these concerns with reference to specific comments made by stakeholders. All of these comments are addressed in the subsequent sections of this assessment.

Table 16-9: Table showing a summary of the main comments received from stakeholders during the Public Consultation Phase during Scoping with key responses

Comment	Commenter	Response
<p>Queries on the water usage of the project.</p>	<p>Adjacent and/or nearby landowners and Interested and Affected Parties (I&APs)</p>	<p>Note that each Kudu Solar Facility will require the following water volumes. <u>This specifically applies to Kudu Solar Facility 1, 2, 3, 4, 6, 9, 10, and 12.</u> Each facility listed here will require the amount of water below:</p> <ul style="list-style-type: none"> ▪ Approximately 9 000 m³ of water is estimated to be required per year for the construction phase. ▪ Approximately 1 000 m³ of water is estimated to be required per year for the operational phase. <p>The following water usage applies to <u>Kudu Solar Facilities 5, 7, 8 and 11</u> each (i.e. each facility listed here will require the amount of water below):</p> <ul style="list-style-type: none"> ▪ Approximately 18 000 m³ of water is estimated to be required per year for the construction phase. ▪ Approximately 2 000 m³ of water is estimated to be required per year for the operational phase. <p>For all the proposed Kudu Solar Facilities, water requirements during the decommissioning phase are unknown at this stage, however it is unlikely to exceed the water requirements of the construction phase.</p> <p>Water required for the construction, operational and decommissioning phases will either be sourced from the following sources (in order of priority and likelihood):</p> <ul style="list-style-type: none"> ▪ Local municipality i.e. most likely trucked in or made available for collection at the Local Municipal Water Treatment Plant via a metered standpipe; ▪ Investigation into a third-party water supplier which may include private services companies. This would most likely be trucked in; ▪ Existing boreholes on site to source groundwater (if available and if suitable); or

Comment	Commenter	Response
		<ul style="list-style-type: none"> ▪ New boreholes that will be drilled on site to source groundwater (if available and if suitable), which will be subject to complete geohydrological testing and an assessment, as well as a Water Use Licence Application process, as well as the necessary Environmental Assessment process (if required). This will be undertaken as a separate process, once more detailed information becomes available, <u>outside of the current Application for EA for the Solar PV Facility and associated infrastructure.</u> <p>Therefore the use of existing boreholes on site to source groundwater (if available and if suitable) is <u>only one of the potential water sources (and it is only the third most likely option, as noted above. Water from the municipality is the first option in terms of viability but consideration of other options is vital).</u></p> <p>A hydrocensus was undertaken as part of this Geohydrology Assessment in order to visit selected boreholes and landowners to obtain information such as yields and to measure the field chemistry to assess the groundwater quality (pH, total dissolved solids (TDS) and electrical conductivity (EC)). An analysis of the hydrocensus chemistry results was also undertaken in terms of the SANS 241-1: 2015 and the Department of Water Affairs and Forestry (DWA) (1998) Standards. Based on this, the groundwater quality in the study area is generally of good quality in terms of pH, TDS and EC. It is possible that the groundwater can be used for potable and domestic purposes with only minor treatment however a full laboratory analysis will be required. With regards to the cleaning of panels, salts could be removed from the groundwater by thermal distillation (i.e. boiling since salt has a much higher boiling point than water) or by membrane separation (commonly reverse osmosis). Both of these techniques are possible but financial viability would have to be determined before commissioning as both techniques are costly on a large scale. Water pipelines may need to be constructed to transfer groundwater from existing boreholes or they may be transported by trucks from the boreholes to the site. Groundwater may also need to be stored on site in suitable containers or reservoir tanks during the construction and operational phases. Ground water storage may trigger the need for a Water Use Licence if there is more than 2000 m³ stored on the site per year in an open container.</p>

Comment	Commenter	Response
<p>Requests for information on the measures in place to test the availability of water resources.</p>	<ul style="list-style-type: none"> ▪ Adjacent and/or nearby landowners and I&APs 	<p><u>These responses are expanded within Section 16.3 and Section 16.6 of this chapter.</u></p> <p>As noted above, a hydrocensus was conducted to confirm the quality of various existing boreholes in the region. However, no drill records or yield test data exists for production or wind pump boreholes to clarify yields and geological logs. Therefore, estimations for groundwater supply capacity for the area are based on regional datasets. For each PV Facility, the anticipated demands are less than the regional yield potential of the underlying aquifer (0.5 – 2.0 L/s). This is considered appropriate for a study undertaken as part of an EIA Process.</p> <p>The study area is located mainly within quaternary catchment D33B with small sections within quaternary catchment D62F. Both of these quaternary catchments form part of the Lower Orange Water Management Area in the Northern Cape. The groundwater General Authorisation (GA) for both of the catchments is 45 m³/ha/a (published on 2 September 2016, in GG 40243, GN 538 (i.e. Revision of GA for the taking and storing of water). If the proposed projects are timed and planned appropriately with regards to groundwater use, all the water can be obtained from groundwater, with the use being Generally Authorised.</p> <p>The impact of the proposed abstraction on groundwater is predicted to be of low significance, with effective implementation of mitigation actions (i.e. to adhere to the borehole’s safe yield and to monitor water levels and flow).</p> <p><u>These responses are expanded on in Section 16.4, Section 16.8 and Section 16.6 of this chapter.</u></p>
<p>Requests for information regarding Water Use Licence Requirements for boreholes.</p>	<p>Adjacent and/or nearby landowners and I&APs</p>	<p>As noted above, for all the proposed Kudu Solar Facilities, the potential sources of water, in order of priority and likelihood, include the: Local municipality, third-party water supplier, existing boreholes or drilled boreholes on site. Therefore, the use of existing boreholes on site to source groundwater is only one of the potential water sources (and it is only the third most likely option, as noted above. Water from the municipality is the first option in terms of viability but consideration of other options is vital).</p>

Comment	Commenter	Response
		<p>In terms of measurements, the Geohydrology Assessment undertook a hydrocensus of the existing boreholes in the area and an analysis of the data, and based on this, the groundwater quality in the study area is generally of good quality in terms of pH, TDS and EC.</p> <p>The study area is located mainly within quaternary catchment D33B with small sections within quaternary catchment D62F. Both of these quaternary catchments form part of the Lower Orange Water Management Area in the Northern Cape. The groundwater GA for both of the catchments is 45 m³/ha/a (published on 2 September 2016, in GG 40243, GN 538 (i.e. Revision of GA for the taking and storing of water)). If the proposed projects are timed and planned appropriately with regards to groundwater use, all the water can be obtained from groundwater, with the use being Generally Authorised. Registration of the usage in terms of the GA with the Department of Water and Sanitation (DWS) would be required.</p> <p><u>These responses are expanded on in Section 16.3, Section 16.4, Section 16.6, and Section 16.8 of this chapter.</u></p>
<p>Requests for information regarding the impact of the development on groundwater resources.</p>	<p>Adjacent and/or nearby landowners and I&APs and I&APs</p>	<p>This Geohydrology Assessment provides feedback on the suitability of the groundwater for usage during the construction and operational phases of the project, and also identifies various potential impacts of the proposed project on the geohydrology, as noted below:</p> <p>Construction Phase:</p> <ul style="list-style-type: none"> ○ Potential lowering of the groundwater level. ○ Potential impact on groundwater quality as a result of accidental oil spillages or fuel leakages. <p>Operational Phase</p> <ul style="list-style-type: none"> ○ Potential lowering of the groundwater level. ○ Potential impact on groundwater quality as a result of using cleaning agents for cleaning the solar panels. ○ Potential impact on groundwater quality as a result of electrolyte that will be used for the BESS.

Comment	Commenter	Response
		<p>Decommissioning Phase</p> <ul style="list-style-type: none"> ○ Potential impact on groundwater quality as a result of accidental oil spillages or fuel leakages. <p>All the impacts have been rated with a low to very low significance with the implementation of mitigation measures. All mitigation measures have been captured in the Environmental Management Programme (EMPr).</p> <p><u>These responses are expanded on in Section 16.3, Section 16.6, and Section 16.9 of this chapter.</u></p>
<p>Queries on the sustainability of groundwater withdrawal for the maintenance of the development.</p>	<p>Adjacent and/or nearby landowners and I&APs and I&APs</p>	<p>The impact of the usage of the ground water during the relevant project phases is addressed in this Geohydrology Assessment, along with the identification of various management actions to address such usage of water, which have been carried over to the EMPr, which is legally binding once approved. Any historical groundwater monitoring by the DWS should be sourced and assessed during all phases of development (once Environmental Authorisation is obtained, should it be granted), and a monitoring program should be instated (water level, chemistry and volumes abstracted). This has been included in the EMPr.</p> <p><u>These responses are expanded on in Section 16.9 of this chapter.</u></p>
<p>Queries on the effect of windpump/boreholes on the supply of drinking water to sheep, cattle, and game farm activities.</p>	<p>Adjacent and/or nearby landowners and I&APs and I&APs</p>	<p>This Geohydrology Assessment assessed the impact of the water required for the proposed development on the environment. With appropriate siting and management measures groundwater impact on existing users can be entirely mitigated. The assessment has identified the lowering of groundwater levels as a result of over-abstraction as a potential impact, of low significance, with the implementation of recommended mitigation measures (i.e. adhere to the borehole's safe yield and to monitor water levels and flow; and boreholes must be correctly yield tested according to the National Standard (SANS 10299-4:2003, Part 4 – Test pumping of water boreholes). This includes a Step Test, Constant Discharge Test and recovery monitoring). This has been included as a requirement in the EMPr.</p> <p>In addition, an appropriate monitoring program will need to be instated to ensure over abstraction of groundwater is not taking place, and/or to ensure that no contamination</p>

Comment	Commenter	Response
		<p>of groundwater is taking place. This will allow the Environmental Control Officer / Environmental Manager of the proposed project (appointed post EA should authorisation be granted, and the proposed project progresses to the commencement phase) to determine the observed effect on the groundwater resources in the area. <u>These responses are expanded on within Section 16.9 within this chapter.</u></p>
<p>Comment regarding the majority of existing windpumps and boreholes being just adequate for sheep; and the impact on water levels due to the drought season.</p>	<p>Adjacent and/or nearby landowners and I&APs</p>	<p>Testing of boreholes, that are planned to be used, will be required to determine if the yields can actually deliver the required volumes. In addition, droughts are seasonal and will occur. The more information that is collected (e.g. monitoring prior to construction) the more certainty there will be on the actual observed effect on the proposed development on the groundwater resources. Therefore, groundwater monitoring is crucial for the protection of the regional groundwater resources. <u>These responses are expanded on within Section 16.9 within this chapter.</u></p>
<p>Comment regarding the ground water being slow running.</p>	<ul style="list-style-type: none"> ▪ Adjacent and/or nearby landowners and I&APs 	<p>As noted above, this will need to be scientifically yield tested. The impact of the usage of groundwater has been assessed in this Geohydrology Assessment. <u>These responses are expanded on within Section 16.9 within this chapter.</u></p>
<p>Comments regarding groundwater moving from south to north.</p>	<ul style="list-style-type: none"> ▪ Adjacent and/or nearby landowners and I&APs 	<p>The comment is agreed with, based on the available information. Groundwater movement is driven by gravity and (generally speaking) flows from high elevations to low elevations. <u>These responses are expanded on within Section 16.4 within this chapter.</u></p>
<p>Comments regarding the depth of the water surface in this area, and its gradual sinking over time and as drought seasons approach.</p>	<ul style="list-style-type: none"> ▪ Adjacent and/or nearby landowners and I&APs 	<p>This can only be confirmed by instatement of an appropriate monitoring program. The requirements for such a program have been documented in the EMPr. <u>These responses are expanded on within Section 16.9 within this chapter.</u></p>
<p>Feedback on the depth of the borehole (and link to the dolerite bank) and the history around the boreholes.</p>	<ul style="list-style-type: none"> ▪ Adjacent and/or nearby landowners and I&APs 	<p>Anecdotal evidence suggests that many of the boreholes were drilled using 'stamper boor' apparatus. It appears this is the average depth of the boreholes (50 – 80 m) in the region. It is agreed that boreholes are typically shallow in the region. This is not to say there is absolutely no water deeper than the average depth of the boreholes in the region. Only several deep boreholes could prove this.</p>

Comment	Commenter	Response
<p>Comment regarding status of the ground water (i.e. fossil water and stored underground for many years).</p>	<ul style="list-style-type: none"> ▪ Adjacent and/or nearby landowners and I&APs 	<p><u>These responses are expanded on within Section 16.4 within this document</u></p> <p>This could be confirmed by isotopic dating of the ground water. There is evidence in the southern portion of the Karoo basin that there are several sources of ground water at variable depths, with variable ages. Deeper groundwater was typically found to be saline, and older (Harkness et al., 2018). However, this is not within the scope of the current assessment, nor is it required in order to assess the overall impacts of ground water usage associated with the proposed project.</p> <p><u>These responses are expanded on within Section 16.4 within this chapter.</u></p>
<p>Comment regarding the supplement of ground water (i.e. slow and occurs only once every few years).</p>	<ul style="list-style-type: none"> ▪ Adjacent and/or nearby landowners and I&APs 	<p>This can be confirmed by yield testing boreholes in the area and implementing monitoring to observe actual effects of groundwater removal/abstraction. The impact of the usage of groundwater has been assessed in this Geohydrology Assessment</p> <p><u>These responses are expanded on within Section 16.9 within this chapter.</u></p>

Comments related to geohydrology impacts associated with the proposed project were raised by Interested and Affected Parties during the review period of the Draft EIA Report. These comments are similar to those submitted and considered during the Scoping Phase, and therefore similar responses apply. Comments were raised in terms of recommendations for groundwater monitoring and in terms of water use licence applications and general authorisations; queries on the water use licence requirements for the project, the amount of groundwater to be used, water availability and drought related concerns, sustainability of groundwater usage, concerns around not distributing the development over a larger area thereby distributing the impact of groundwater abstraction and increasing sustainable abstraction, groundwater flow, and chemical pollution of grazing land. Responses have been provided in Appendix H.7 of the Final EIA Report.

16.6 Impact Assessment

16.6.1 Potential Impacts during the Construction Phase

The impact table for the Construction Phase is presented in Table 16-11.

16.6.1.1 Impact 1: Groundwater impact as a result of over-abstraction from construction requirements

During the construction phase the project plans to use 9 000 m³/a (0.29 L/s) (Table 16-10). This requirement is within the expected capacity of the aquifer (0.5-2.0 L/s) therefore the risk associated to this impact is considered to be low. It must be noted that the study area is known to experience extreme droughts and therefore even though the construction groundwater demand is within the yield potential of the aquifer, adherence to the mitigation measures during the construction phase is vital.

The status of this impact is rated as negative with a local spatial extent and a short-term duration (i.e. for the construction phase). The consequence and probability of the impact are respectively rated as substantial and likely. The reversibility of the impact is rated as high and the irreplaceability is rated low. The significance of the impact without the implementation of mitigation measures is rated as moderate. With effective implementation of prevention / mitigation actions (i.e. to adhere to the borehole's safe yield and to monitor water levels and flow etc.), the impact of the proposed abstraction on groundwater is predicted to be of low significance.

Table 16-10: Extent and water requirements of the Kudu Solar Facility 7

Solar Facility	Size (MWac)	Construction Requirement (m ³)	Operational Requirement (m ³)
7	350	18000	2000

Impact 2: Potential Impact on Groundwater Quality as a result of Accidental Oil Spillages or Fuel Leakages

If there is an accidental oil spill or fuel leakage during the construction phase, then the low permeability of the unsaturated zone will provide significant attenuation capacity. The status of this impact (for the construction phase) is rated as negative with a site-specific spatial extent and short-term duration. The consequence and probability of the impact are respectively rated as slight and extremely unlikely. The reversibility of the impact is rated as high and the irreplaceability is rated as low. The significance of the impact without the implementation of mitigation measures is rated as very low.

A precautionary approach must be implemented and reasonable measures must be undertaken to prevent oil spillages and fuel leakages from occurring. During the construction phase, vehicles must be regularly serviced and maintained to check and ensure there are no leakages. Any engines that stand in one place for an excessive length of time must have drip trays. Diesel fuel storage tanks, if required, should be above ground on an impermeable concrete surface in a bunded area. Construction vehicles and equipment should also be refuelled on an impermeable surface. A designated area should be established at the construction site camp for this purpose, if

off-site refuelling is not possible. If spillages occur, they should be contained and removed as rapidly as possible, with correct disposal procedures of the spilled material, and reported. Proof of disposal (waste disposal slips or waybills) should be obtained and retained on file for auditing purposes.

With effective implementation of these prevention / mitigation actions, the impact of the project on groundwater as a consequence of accidental oil spillages and fuel leakages is predicted to be of very low significance.

Table 16-11: Impact Summary Tables: Construction Phase

Impact	Impact Criteria		Significance and Ranking (Pre-Mitigation)	Potential mitigation measures	Significance and Ranking (Post-Mitigation)	Confidence Level
CONSTRUCTION PHASE						
Lowering of groundwater levels as a result of over-abstraction	Status	Negative	Moderate	<ul style="list-style-type: none"> ▪ Adhere to the borehole's safe yield and to monitor water levels and flow. ▪ Boreholes must be correctly yield tested according to the National Standard (SANS 10299-4:2003, Part 4 – Test pumping of water boreholes). This includes a Step Test, Constant Discharge Test and recovery monitoring. 	Low	High
	Spatial Extent	Local				
	Duration	Short Term				
	Consequence	Substantial				
	Probability	Likely				
	Reversibility	High				
Irreplaceability	Low					
Accidental oil spillage / fuel leakage	Status	Negative	Very Low	<ul style="list-style-type: none"> ▪ Vehicles must be regularly serviced and maintained to check and ensure there are no leakages. Any engines that stand in one place for an excessive length of time must have drip trays. Diesel fuel storage tanks, if required, should be above ground on an impermeable surface in a bunded area. Vehicles and equipment should also be refuelled on an impermeable surface. A designated area should be established at the construction site camp for this purpose, if off-site refuelling is not possible. If spillages occur, they should be contained and removed as rapidly as possible, with correct disposal procedures of the spilled material, and reported. Proof of disposal (waste disposal slips or waybills) should be obtained and retained on file for auditing purposes 	Very Low	High
	Spatial Extent	Site Specific				
	Duration	Short Term				
	Consequence	Slight				
	Probability	Extremely Unlikely				
	Reversibility	High				
Irreplaceability	Low					

16.6.2 Potential Impacts during the Operational Phase

The impact table for the Operational Phase is presented in Table 16-12.

16.6.2.1 Impact 1: Groundwater impact as a result of over-abstraction from operational requirements

During the operational phase the peak requirement is estimated to be 2 000 m³/a (0.06 L/s) for the PV Facility (Table 16-10). Therefore, the groundwater requirement for the operational phase is within the yield potential of the underlying aquifer (0.5 – 2.0 L/s). It must be noted that the study area is known to experience extreme droughts and therefore even though the operational groundwater demand is within the yield potential of the aquifer, adherence to the mitigation measures during the operational phase is vital.

The status of this impact is rated as negative with a local spatial extent and a long-term duration (i.e. for the life of the project). The consequence and probability of the impact are respectively rated as substantial and likely. The reversibility of the impact is rated as high and the irreplaceability is rated low. The significance of the impact without the implementation of mitigation measures is rated as moderate. With effective implementation of prevention / mitigation actions (i.e. to adhere to the borehole's safe yield and to monitor water levels and flow), the impact of the proposed abstraction on groundwater is predicted to be of low significance.

16.6.2.2 Impact 2: Potential impact on groundwater quality as a result of using cleaning agents

The low permeability of the unsaturated zone will provide significant attenuation capacity. The status of this impact (for the operational phase) is rated as negative with a site-specific spatial extent and long-term duration (i.e. for the life of the project). The consequence and probability of the impact are respectively rated as slight and extremely unlikely. The reversibility of the impact is rated as high and the irreplaceability is rated as low. The significance of the impact without the implementation of mitigation measures is rated as very low. Recommended mitigation measures include using environmentally safe cleaning agents that breakdown naturally and do not cause adverse effects. With adherence to the proposed mitigation measures the significance of this impact would also be rated as very low.

16.6.2.3 Impact 3: Potential impact on groundwater quality as a result of electrolyte that will be used for the BESS

The proposed development will require a BESS at the facility. There are usually electrolytes of an environmentally harmful chemical composition that are used within the BESS, especially for Redox Flow BESS (whereas Lithium Ion BESS are solid state containerized systems). With any chemical storage there is always a risk of contamination to soils and groundwater. The status of this impact (for the operational phase) is rated as negative with a site-specific spatial extent and long-term duration (i.e. for the life of the project). The consequence and probability of the impact are respectively rated as substantial and very unlikely. The reversibility of the impact is rated as high and the irreplaceability is rated as low. The significance of the impact without the implementation of mitigation measures is rated as low. It is recommended that all BESS's are placed a minimum of 50m from any borehole and include effective bunding and secondary containment structures. With adherence to the proposed mitigation measures the significance of this impact would be rated as very low.

Table 16-12: Impact Summary Tables: Operational Phase

Impact	Impact Criteria		Significance and Ranking (Pre-Mitigation)	Potential mitigation measures	Significance and Ranking (Post-Mitigation)	Confidence Level
OPERATIONAL PHASE						
Lowering of groundwater levels as a result of over- abstraction	Status	Negative	Moderate	<ul style="list-style-type: none"> Adhere to the borehole's safe yield and to monitor water levels and flow. Boreholes must be correctly yield tested according to the National Standard (SANS 10299-4:2003, Part 4 – Test pumping of water boreholes). This includes a Step Test, Constant Discharge Test and recovery monitoring. 	Low	High
	Spatial Extent	Local				
	Duration	Long Term				
	Consequence	Substantial				
	Probability	Likely				
	Reversibility	High				
	Irreplaceability	Low				
Potential impact on groundwater quality as a result of using cleaning agents	Status	Negative	Very Low	<ul style="list-style-type: none"> Use environmentally safe cleaning agents that breakdown naturally and do not cause adverse effects. 	Very Low	High
	Spatial Extent	Site Specific				
	Duration	Long Term				
	Consequence	Slight				
	Probability	Extremely Unlikely				
	Reversibility	High				
	Irreplaceability	Low				
Potential impact on groundwater quality as a result of electrolyte that will be used for the BESS	Status	Negative	Low	<ul style="list-style-type: none"> Ensure that all electrolyte or chemicals stored or used on site have secondary containment systems in place with reliable leak detection, annunciation in place. Ensure that all chemicals are handled on concrete bunded surfaces and not on bare soil. Any waste products produced from the BESS systems should be removed and disposed of appropriately. 	Very Low	High
	Spatial Extent	Site Specific				
	Duration	Long Term				
	Consequence	Substantial				
	Probability	Very Unlikely				
	Reversibility	High				
	Irreplaceability	Low				

<i>Impact</i>	<i>Impact Criteria</i>	<i>Significance and Ranking (Pre-Mitigation)</i>	<i>Potential mitigation measures</i>	<i>Significance and Ranking (Post-Mitigation)</i>	<i>Confidence Level</i>
OPERATIONAL PHASE					
			<ul style="list-style-type: none"> ▪ <i>Waste water produced by fire hydrants should not be allowed to runoff into the environment. It is recommended that all BESS's are placed a minimum of 50m from any borehole.</i> 		

16.6.3 Potential Impacts during the Decommissioning Phase

The impact table for the Decommissioning Phase is presented in Table 16-13.

16.6.3.1 Impact 1: Potential Impact on Groundwater Quality as a result of Accidental Oil Spillages or Fuel Leakages

During the decommissioning phase the main impact is linked to the potential for accidental oil spillages due to the machinery that will be used to decommission the site. The same applies as in the construction phase, therefore, if there is an accidental oil spill or fuel leakage during the decommissioning phase the low permeability of the unsaturated zone will provide significant attenuation capacity. The status of this impact (for the decommissioning phase) is rated as negative with a site-specific spatial extent and short-term duration. The consequence and probability of the impact are respectively rated as slight and extremely unlikely. The reversibility of the impact is rated as high and the irreplaceability is rated as low. The significance of the impact without the implementation of mitigation measures is rated as very low. A precautionary approach must be implemented and reasonable measures must be undertaken to prevent oil spillages and fuel leakages from occurring. During the decommissioning phase, vehicles must be regularly serviced and maintained to check and ensure there are no leakages. Any engines that stand in one place for an excessive length of time must have drip trays. Diesel fuel storage tanks, if required, should be above ground on an impermeable concrete surface in a bunded area. Vehicles and equipment should also be refuelled on an impermeable surface. A designated area should be established at the site camp for this purpose, if off-site refuelling is not possible. If spillages occur, they should be contained and removed as rapidly as possible, with correct disposal procedures of the spilled material, and reported. Proof of disposal (waste disposal slips or waybills) should be obtained and retained on file for auditing purposes. With effective implementation of these prevention / mitigation actions, the impact of the project on groundwater as a consequence of accidental oil spillages and fuel leakages is predicted to be of very low significance.

16.6.3.2 Impact 2: Groundwater impact as a result of over-abstraction from decommissioning requirements

Although water requirements during the decommissioning phase were not specificized, it is unlikely that they will exceed the water requirements of the construction phase. As such, this potential impact has been evaluated at a potential maximum requirement of 18 000 m³/a (0.6 L/s). This requirement is within the expected capacity of the aquifer (0.5-2.0 L/s) therefore the risk associated to this impact is considered to be low. It must be noted that the study area is known to experience extreme droughts and therefore even though the construction groundwater demand is within the yield potential of the aquifer, adherence to the mitigation measures during the decommissioning phase is vital.

The status of this impact is rated as negative with a local spatial extent and a short-term duration (i.e. for the decommissioning phase). The consequence and probability of the impact are respectively rated as substantial and likely. The reversibility of the impact is rated as high and the irreplaceability is rated low. The significance of the impact without the implementation of mitigation measures is rated as moderate. With effective implementation of prevention / mitigation actions (i.e. to adhere to the borehole's safe yield and to monitor water levels and flow etc.), the impact of the proposed abstraction on groundwater is predicted to be of low significance.

Table 16-13: Impact Summary Tables: Decommissioning Phase

Impact	Impact Criteria		Significance and Ranking (Pre-Mitigation)	Potential mitigation measures	Significance and Ranking (Post-Mitigation)	Confidence Level
DECOMMISSIONING PHASE						
Accidental oil spillage / fuel leakage	Status	Negative	Very Low	<ul style="list-style-type: none"> Vehicles must be regularly serviced and maintained to check and ensure there are no leakages. Any engines that stand in one place for an excessive length of time must have drip trays. Diesel fuel storage tanks, if required, should be above ground on an impermeable surface in a bunded area. Vehicles and equipment should also be refuelled on an impermeable surface. A designated area should be established at the site camp for this purpose, if off-site refuelling is not possible. If spillages occur, they should be contained and removed as rapidly as possible, with correct disposal procedures of the spilled material, and reported. Proof of disposal (waste disposal slips or waybills) should be obtained and retained on file for auditing purposes. 	Very Low	High
	Spatial Extent	Site Specific				
	Duration	Short Term				
	Consequence	Slight				
	Probability	Extremely Unlikely				
	Reversibility	High				
	Irreplaceability	Low				
Lowering of groundwater levels as a result of over-abstraction	Status	Negative	Moderate	<ul style="list-style-type: none"> Adhere to the borehole's safe yield and to monitor water levels and flow. Boreholes must be correctly yield tested according to the National Standard (SANS 10299-4:2003, Part 4 – Test pumping of water boreholes). This includes a Step Test, Constant Discharge Test and recovery monitoring. 	Low	High
	Spatial Extent	Local				
	Duration	Short Term				
	Consequence	Substantial				
	Probability	Likely				
	Reversibility	High				
	Irreplaceability	Low				

16.6.4 Potential Cumulative Impacts

The cumulative impacts of the proposed Kudu Solar Facility and other approved and in process renewable energy facilities and electricity grid infrastructure (EGI) within a 30 km radius from the study area are presented in this section. The cumulative impacts identified include the impacts related to the construction, operational and decommissioning phases across proposed Kudu Solar Facility. In general, the impacts during the different phases of the project are quite similar, therefore, their intensities increase as the project progresses resulting in a higher probability for the impact to occur.

According to information collected by the CSIR from the Renewable Energy EIA Database and the South African Heritage Resources Information System (SAHRIS) (~February 2023), 12 other renewable energy facilities and EGI have been approved, or in the process of approval in terms of the NEMA EIA Regulations, that are located with a 30 km radius from the Kudu Solar Facilities (Map 16-10). Three of these renewable energy facilities are already existing and operational. In addition, approximately 10 existing Eskom power lines fall within the 30 km radius of the proposed project, with three Eskom planned power line projects, as shown in Map 16-10. Failing to implement effective mitigation measures throughout the lifespan of projects might cause the intensity of different identified impacts to increase. Appendix F of this chapter contains Table 16-19 covering the details of approved projects within a 30 km radius of the proposed Kudu Solar Facility as provided by the CSIR.

The types of impacts of these developments are nearly identical to each other, with the main cumulative effect being an increase in impact duration and likelihood for the construction, operational, and decommissioning phase. These increases are especially exacerbated for the construction phase, in the case that construction of all the proposed developments within a 30km radius occurs simultaneously. Of special concern is the cumulative effect of the proposed Odyssey and Crossroads Green Energy Cluster projects which fall within a 10 km radius of the Kudu Project. It must be reiterated that these projects are still in their Environmental Assessment Phases. The cumulative impact of all these developments during the operational phase should be quite low as long as the proposed mitigation measures and appropriate ground water monitoring is implemented.

The cumulative impacts include all the potential impacts discussed in section 16.6.1, 16.6.2, 16.6.3 and the potential impacts of other wind and solar, and EGI projects within a 30km radius, see Map 16-10 and Appendix F of this chapter. As such, the cumulative impacts are:

- Potential lowering of groundwater level during the construction and operational phase for all 12 of the proposed Kudu Solar PV facilities, Odyssey, and Crossroads projects.
- Potential of impact on groundwater quality as a result of accidental oil spillages or fuel leakages from the construction and the decommissioning phases for the proposed 12 Kudu Solar PV facilities, Keren Energy Odyssey, and Crossroads projects.
- Potential of impact on groundwater quality as a result of using cleaning agents for cleaning the solar panels during the operational phases for all 12 proposed Kudu Solar PV facilities, Keren Energy Odyssey, and Crossroads projects
- Potential impact on groundwater quality as a result of electrolyte that will be used for the BESS).
- Other wind and solar, and EGI projects within a 30 km radius.

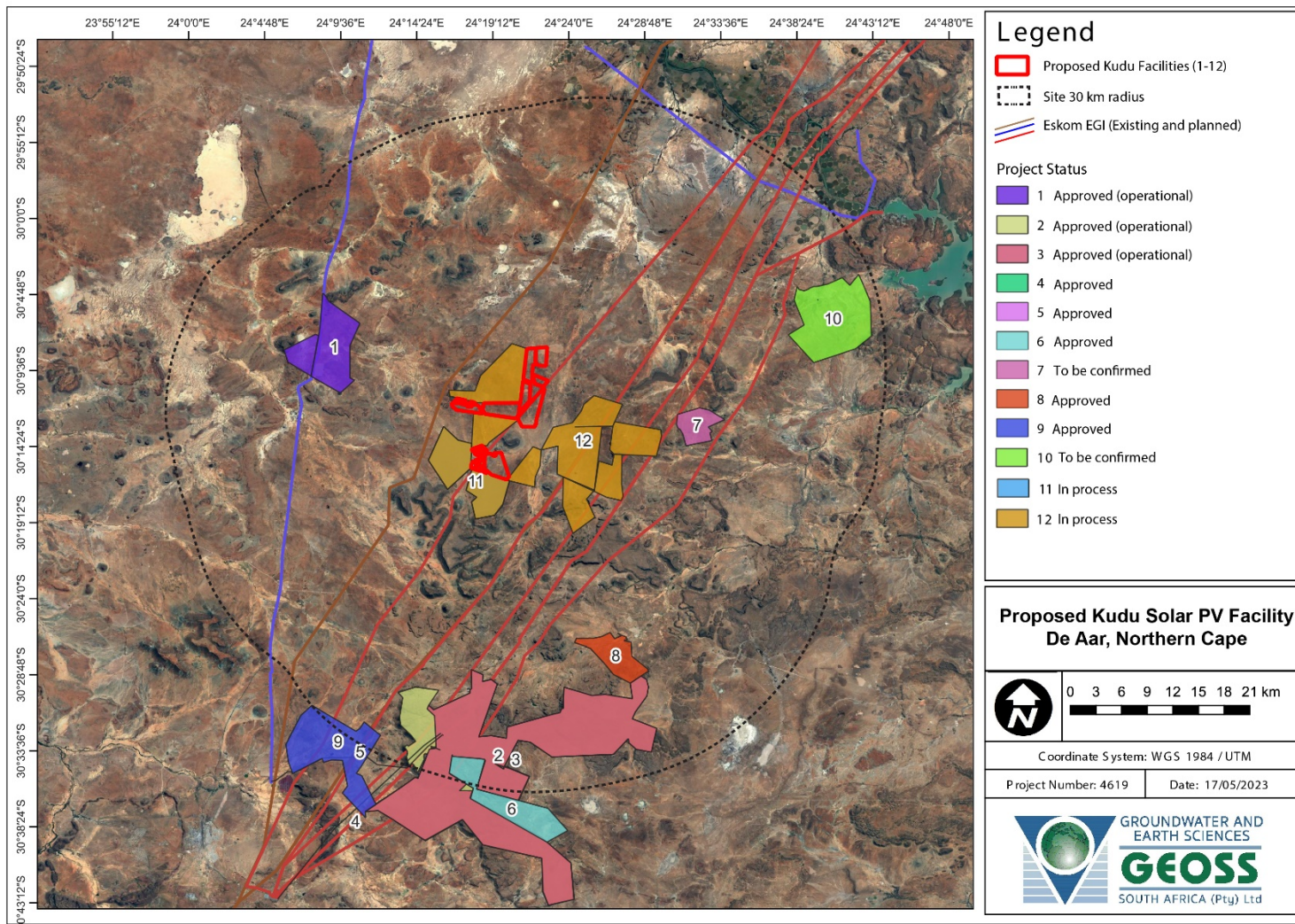

Map 16-10: Map showing the proposed Kudu Solar PV Facility in relation to other local authorised, in process or operational renewable projects

16.6.4.1 Impact 1: Groundwater impact as a result of over-abstraction from construction, operation, and decommissioning requirements

As an overview and as noted above, water requirements for individual facilities divided based on their capacities (MWac) are as follows (Table 16-14):

- Kudu Solar Facilities 1, 2, 3, 4, 6, 9, 10 and 12 (i.e. those projects up to 150 MWac):
 - Construction Phase: 9 000 m³/a/facility (~0.29 L/s/facility).
 - Operational Phase: 1 000 m³/a/facility (~0.03 L/s/facility).
- Kudu Solar Facility 5, 7, 8 and 11 (i.e. those projects with a capacity of more than 150 MWac but up to 350 MWac):
 - Construction Phase: 18 000 m³/a/facility (~0.60 L/s/facility).
 - Operational Phase: 2 000 m³/a/facility (~0.06 L/s/facility).

During the construction phase, cumulatively across all facilities (1 to 12) this equates to 144 000 m³/a (~4.6 L/s) (Table 16-14). Thus, if all facilities are developed during the same year the proposed groundwater abstraction is higher than the yield potential of the underlying aquifer (0.5 – 2.0 L/s). However, it is unlikely that all 12 facilities will be developed in the same year and additionally, the extent over which the water will be required (and likely abstracted), is expected to reduce the volume required from any single borehole. Adherence to mitigation measures during the construction phase is vital. As mentioned earlier in the report, the use of existing boreholes to source groundwater (if available and suitable) is only the third most likely water use option. Water sourced from the municipality is the first option in terms of viability, but consideration of other options is vital.

During the operational phase, cumulatively across all facilities (1 to 12) this equates to 16 000 m³/a (~0.5 L/s) (Table 16-14). Therefore, the groundwater requirement for the operational phase of all 12 projects is within the yield potential of the underlying aquifer (0.5 – 2.0 L/s). It must be noted that the study area is known to experience extreme droughts and therefore even though the operational groundwater demand is within the yield potential of the aquifer, adherence to the mitigation measures during the operational phase is vital.

Due to the large spatial extent (30 km radius), most of the other authorised facilities are more than 10 km from the Kudu Solar Facilities and will likely have little influence on the Kudu Solar Facility. This includes the associated power lines which have a low enough water requirement as to not greatly impact the geohydrological conditions of the region.

Of special concern would be the cumulative impact of the adjacent Odyssey and Crossroads Green Energy Cluster projects which, although still in the EIA phase, are within a 10 km radius of the Kudu Solar Project. Although no data on the expected water usage of the Crossroads and Odyssey projects was interrogated, generalised water requirements for Solar PV projects suggest that there is a much higher risk of over abstraction should all these projects be constructed simultaneously, as opposed to one at a time. In the event that construction of the Keren Energy Odyssey, Crossroads, and Kudu projects occurs simultaneously the cumulative impact is regarded as moderate significance without the implementation of mitigation measures. This impact has a variable duration dependent on whether the proposed sites are constructed simultaneously (short

term) or in several phases (medium term). In the event of multiple projects being constructed at the same time, the monitoring program needs to be strictly adhered to so as to prevent over abstraction. By adhering to the proposed mitigation measures the impact can be regarded as low significance.

During the operational phases the cumulative water use should still be below the regional groundwater yield; however, this interpretation is only based on generalised water requirements for Solar PV facilities.

For the operational phase, the impact is also rated as moderate significance before mitigation and low significance with mitigation, with the same mitigation measures discussed above.

Similar impact ratings have been provided for the decommissioning phase as for the operational phase.

Table 16-14: Summary of anticipated water requirements of solar facilities during construction and operational phases.

Facility	Size (MWac)	Construction (m3/a)	Operational (m3/a)	Construction (L/s)	Operational (L/s)
1	50	9000	1000	0,285	0,032
2	50	9000	1000	0,285	0,032
3	50	9000	1000	0,285	0,032
4	50	9000	1000	0,285	0,032
6	150	9000	1000	0,285	0,032
9	150	9000	1000	0,285	0,032
10	150	9000	1000	0,285	0,032
12	150	9000	1000	0,285	0,032
<i>Cumulative <150 MWac</i>		<i>72000</i>	<i>8000</i>	<i>2,283</i>	<i>0,254</i>
5	350	18000	2000	0,571	0,063
7	350	18000	2000	0,571	0,063
8	350	18000	2000	0,571	0,063
11	330	18000	2000	0,571	0,063
<i>Cumulative >150 <350 MWac</i>		<i>72000</i>	<i>8000</i>	<i>2,283</i>	<i>0,254</i>
<i>Cumulative</i>		<i>144000</i>	<i>16000</i>	<i>4,566</i>	<i>0,507</i>

16.6.4.2 Impact 2: Potential Impact on Groundwater Quality as a result of Accidental Oil Spillages or Fuel Leakages during the construction and decommissioning phases

If there is an accidental oil spill or fuel leakage during any of the project phases, then the low permeability of the unsaturated zone will provide significant attenuation capacity. This potential cumulative impact is mainly limited to the construction and decommissioning phase of the development. The status of this impact is rated as negative with a site-specific spatial extent and a variable duration dependent on whether the proposed sites are constructed and decommissioned simultaneously (short term) or in several phases (medium term). The consequence and probability of the impact are respectively rated as slight and unlikely (phased construction/decommissioning)

to likely (simultaneous construction/decommissioning). The reversibility of the impact is rated as high and the irreplaceability is rated as low. The significance of the impact without the implementation of mitigation measures is rated as very low.

The mitigation measures for this impact are the same as that discussed above for the construction and decommissioning phases.

With effective implementation of these prevention / mitigation actions, the impact of the project on groundwater as a consequence of accidental oil spillages and fuel leakages is predicted to be of very low significance.

16.6.4.3 Impact 3: Potential impact on groundwater quality as a result of using cleaning agents during the operational phase

The low permeability of the unsaturated zone will provide significant attenuation capacity. The status of this impact is limited mostly to the operational phase, and is rated as negative with a site-specific spatial extent and long-term duration (i.e. for the life of the project). The consequence and probability of the impact are respectively rated as slight and unlikely. The reversibility of the impact is rated as high and the irreplaceability is rated as low. The significance of the impact without the implementation of mitigation measures is rated as very low. Recommended mitigation includes using an environmentally safe cleaning agent that breakdown naturally and do not cause adverse effects. With adherence to the proposed mitigation measures the significance of this impact would also be rated as very low.

16.6.4.4 Impact 4: Potential impact on groundwater quality as a result of electrolyte that will be used for the BESS during the operational phase

The status of this impact is limited primarily to the operational phase, and is rated as negative with a site-specific spatial extent and long-term duration (i.e. for the life of the project). The consequence and probability of the impact are respectively rated as substantial and unlikely. The reversibility of the impact is rated as high and the irreplaceability is rated as low. The significance of the impact without the implementation of mitigation measures is rated as moderate. It is recommended that all BESS's are placed a minimum of 50m from any borehole and include effective bunding and secondary containment structures. With adherence to the proposed mitigation measures the significance of this impact would be rated as low.

16.6.4.5 Concluding Cumulative Summary: Potential impacts during the construction, operational, and decommissioning phases of other wind and solar, and EGI projects within a 30 km radius.

When including each of the Kudu PV clusters as separate entities, a total of 22 renewable power projects are either operational, proposed, or in the environmental approval phase within a 30 km radius of the Kudu Solar PV 7 (see Appendix F). Of these only the Cross Roads Green Energy Cluster and Keren Energy Odyssey Solar PV Facilities (environmental approval in process for both) are within 10 km radius of the Kudu Solar Facility (should Environmental Authorisations be granted). Accordingly, only these projects would be considered to have an appreciable cumulative impact on the underlying aquifer. Both these projects are solar PV projects and, therefore, have very similar impacts to those of the Kudu Solar Facility, namely over abstractions of groundwater, and potential aquifer contamination from oil spills, solar panel cleaning agents, and electrolytes from associated BESS infrastructure. The mitigations for each of these impacts is discussed in the subsections above.

16.6.4.6 Impact Summary Tables: Cumulative Impacts

Impact	Impact Criteria		Significance and Ranking (Pre-Mitigation)	Potential mitigation measures	Significance and Ranking (Post-Mitigation)	Confidence Level
CONSTRUCTION PHASE						
Lowering of groundwater levels as a result of over-abstraction	Status	Negative	Moderate	<ul style="list-style-type: none"> ▪ Adhere to the borehole's safe yield and to monitor water levels and flow. Boreholes must be correctly yield tested according to the National Standard (SANS 10299-4:2003, Part 4 – Test pumping of water boreholes). This includes a Step Test, Constant Discharge Test and recovery monitoring. ▪ A monitoring program needs to be adhered to so as to determine and remain below safe abstraction rates. 	Low	High
	Spatial Extent	Local				
	Duration	Short Term to Medium Term				
	Consequence	Substantial				
	Probability	Likely				
	Reversibility	High				
	Irreplaceability	Low				
Accidental oil spillage / fuel leakage	Status	Negative	Very Low	<ul style="list-style-type: none"> ▪ Vehicles must be regularly serviced and maintained to check and ensure there are no leakages. Any engines that stand in one place for an excessive length of time must have drip trays. Diesel fuel storage tanks, if required, should be above ground on an impermeable surface in a bunded area. Vehicles and equipment should also be refuelled on an impermeable surface. A designated area should be established at the construction site camp for this purpose, if off-site refuelling is not possible. If spillages occur, they should be contained and removed as rapidly as possible, with correct disposal procedures of the spilled material, and reported. Proof of disposal (waste disposal slips or waybills) should be obtained and retained on file for auditing purposes. 	Very Low	High
	Spatial Extent	Site Specific				
	Duration	Short term to Medium Term				
	Consequence	Slight				
	Probability	Unlikely to Likely				
	Reversibility	High				
	Irreplaceability	Low				

Impact	Impact Criteria		Significance and Ranking (Pre-Mitigation)	Potential mitigation measures	Significance and Ranking (Post-Mitigation)	Confidence Level
OPERATIONAL PHASE						
Lowering of groundwater levels as a result of over-abstraction	Status	Negative	Moderate	<ul style="list-style-type: none"> ▪ Adhere to the borehole's safe yield and to monitor water levels and flow. Boreholes must be correctly yield tested according to the National Standard (SANS 10299-4:2003, Part 4 – Test pumping of water boreholes). This includes a Step Test, Constant Discharge Test and recovery monitoring. ▪ A monitoring program needs to be adhered to so as to determine and remain below safe abstraction rates. 	Low	High
	Spatial Extent	Local				
	Duration	Long Term				
	Consequence	Substantial				
	Probability	Likely				
	Reversibility	High				
	Irreplaceability	Low				
Potential impact on groundwater quality as a result of using cleaning agents	Status	Negative	Very Low	<ul style="list-style-type: none"> ▪ Use environmentally safe cleaning agents that breakdown naturally and do not cause adverse effects. 	Very Low	High
	Spatial Extent	Site Specific				
	Duration	Long Term				
	Consequence	Slight				
	Probability	Unlikely				
	Reversibility	High				
	Irreplaceability	Low				
Potential impact on groundwater quality as a result of electrolyte that will be used for the BESS	Status	Negative	Moderate	<ul style="list-style-type: none"> ▪ Ensure that all electrolyte or chemicals stored or used on site have secondary containment systems in place with reliable leak detection, annunciation in place. Ensure that all chemicals are handled on concrete bunded surfaces and not on bare soil. Any waste products produced from the BESS systems should be removed and disposed of appropriately. Waste water produced by fire hydrants should not be allowed to runoff into the environment. It is recommended that all BESS's are placed a minimum of 50m from any borehole. 	Low	High
	Spatial Extent	Site Specific				
	Duration	Long Term				
	Consequence	Substantial				
	Probability	Unlikely				
	Reversibility	High				
	Irreplaceability	Low				

Impact	Impact Criteria		Significance and Ranking (Pre-Mitigation)	Potential mitigation measures	Significance and Ranking (Post-Mitigation)	Confidence Level
DECOMMISSIONING PHASE						
Accidental oil spillage / fuel leakage	Status	Negative	Very Low	<ul style="list-style-type: none"> Vehicles must be regularly serviced and maintained to check and ensure there are no leakages. Any engines that stand in one place for an excessive length of time must have drip trays. Diesel fuel storage tanks, if required, should be above ground on an impermeable surface in a bunded area. Vehicles and equipment should also be refuelled on an impermeable surface. A designated area should be established at the site camp for this purpose, if off-site refuelling is not possible. If spillages occur, they should be contained and removed as rapidly as possible, with correct disposal procedures of the spilled material, and reported. Proof of disposal (waste disposal slips or waybills) should be obtained and retained on file for auditing purposes. 	Very Low	High
	Spatial Extent	Site Specific				
	Duration	Short to Medium Term				
	Consequence	Slight				
	Probability	Unlikely to Likely				
	Reversibility	High				
	Irreplaceability	Low				
Lowering of groundwater levels as a result of over-abstraction	Status	Negative	Moderate	<ul style="list-style-type: none"> Adhere to the borehole's safe yield and to monitor water levels and flow. Boreholes must be correctly yield tested according to the National Standard (SANS 10299-4:2003, Part 4 – Test pumping of water boreholes). This includes a Step Test, Constant Discharge Test and recovery monitoring. A monitoring program needs to be adhered to so as to determine and remain below safe abstraction rates. 	Low	High
	Spatial Extent	Local				
	Duration	Short Term to Medium Term				
	Consequence	Substantial				
	Probability	Likely				
	Reversibility	High				
	Irreplaceability	Low				

16.6.5 No-go Alternatives

The potential groundwater impacts of the No-go alternative for the proposed Kudu PV Solar Facility 7 are also considered. Presently, the sites proposed for development is used mainly for agricultural purposes, i.e. open fields for grazing of various types of livestock. In the scenario that the PV facility did not go ahead it would be expected that these activities would continue and represents the baseline against which other impacts can be compared.

The farm portions where Kudu PV Solar Facility 7 is proposed does not currently utilize significant volumes of groundwater and small-scale abstraction is predominantly for domestic purposes. As such the No-go alternative does not represent a risk to groundwater or aquifer depletion.

However, as noted above, there is a low water demand in the study area and a large spatial extent; and the impacts relating to the use of ground water are not considered to be very significant, especially if the projects are planned and phased suitably.

16.6.6 Battery Energy Storage System

As noted above, Lithium-Ion BESS and Redox Flow BESS were both considered for the proposed project. For Redox Flow BESS, various chemical compositions are likely, such as Vanadium. Refer to Chapter 15 of this EIA Report for a High-Level Safety, Health and Environment Risk Assessment, which provides high level information on the safety, health and environmental risks of the BESS technologies.

Both BESS technologies have been considered in this assessment. The risks associated with each individual technology is such that, with strict adherence to the appropriate mitigation measures, both technologies will have little risk to the local hydrogeological system. Furthermore, no fatal flaws of either technology with respect to the geohydrological system have been identified. Considering this, both Lithium Ion BESS and Redox Flow BESS are considered suitable and no preference is given to either one.

16.7 Impact Assessment Summary

The overall impact significance findings, following the implementation of the proposed mitigation measures are shown in Table 16-15.

Table 16-15: Overall Impact Significance

Phase	Overall Impact Significance (Pre-Mitigation)	Overall Impact Significance (Post Mitigation)
Construction	Moderate to Very Low	Low-Very Low
Operational	Moderate to Very Low	Low-Very Low
Decommissioning	Very Low	Very Low
Nature of Impact	Overall Impact Significance (Pre-Mitigation)	Overall Impact Significance (Post Mitigation)
Cumulative - Construction	Moderate to Very Low	Low-Very Low
Cumulative - Operational	Moderate to Very Low	Low-Very Low
Cumulative - Decommissioning	Very Low	Very Low

The cumulative demands of simultaneous construction (~4.6 L/s) for all twelve planned Kudu Solar Facilities exceeds the regional yield potential of the underlying aquifer (0.5 – 2.0 L/s). This will also likely be the case should construction of the surrounding Keren Energy Odyssey Solar PV Facilities and the Crossroads Green Energy Cluster occur at the same time as construction of the Kudu Solar Facilities. In the event that construction of the above-mentioned projects occurs at the same time, adherence to the recommended mitigation measures should be strictly followed to prevent over abstraction.

The cumulative impacts on groundwater quality due to the construction and operation of the PV facilities for the Kudu Solar Facility are considered Low to Very Low, provided that responsible construction practices are adopted, and the proposed mitigation measures are utilized; for example, use of environmentally cleaning agents.

16.8 Legislative and Permit Requirements

The NWA is administered by the DWS and is the main legislation for managing water resources in South Africa. The purpose of the NWA is to provide a framework for the equitable allocation and sustainable management of water resources. Both surface and groundwater sources are redefined by the Act as national resources which cannot be owned by any individual, and rights to which are not automatically coupled to land rights, but for which prospective users must apply for authorization and register as users. The NWA also provides for measures to prevent, control and remedy the pollution of surface and groundwater sources.

The proposed project is located mainly within quaternary catchment D33B with small sections within quaternary catchment D62F. Both of these quaternary catchments form part of the Lower Orange Water Management Area in the Northern Cape. The groundwater General Authorisation (GA) for both of the catchments is 45 m³/ha/a (published on 2 September 2016, in Government Gazette 40243, Government Notice (GN) 538 (i.e. Revision of General authorisation for the taking and storing of water)). The farm portions with the associated hectares and allowable abstraction under GA is presented in Table 16-16. The allowable abstraction under the GA is capped at 40 000

m³/a per farm portion and therefore the majority of the farm portions are capped at 40 000 m³/a due to the size.

The total allowable volume of groundwater the project can abstract within the GA is 234 650 m³/a which is higher than the peak requirement during the construction phase of 144 000 m³/a for all 12 Kudu Solar Facilities (Table 16-16). Therefore, if the project is planned appropriately with regards to groundwater use, all the water can be obtained from groundwater, with the use being Generally Authorised. Registration of the usage in terms of the GA with DWS would be required. Alternatively, to source all the water from the Remaining Extent of Portion 2 (Middel Plaats) (a portion of Portion 1) of the Farm Grasspan No. 40, a Water Use License Application will be required to meet the demands of the construction period. In the case of water storage, a total of 2000 m³/a can be stored on the property in an open container.

Table 16-16: Farm portions affected by the proposed Kudu Solar Facilities; relevant portion highlighted in blue.

Farm Portion Name	Size (ha)	Kudu Solar 1	Kudu Solar 2	Kudu Solar 3	Kudu Solar 4	Kudu Solar 5	Kudu Solar 6	Kudu Solar 7	Kudu Solar 8	Kudu Solar 9	Kudu Solar 10	Kudu Solar 11	Kudu Solar 12	Allowable abstraction under GA (m ³ /a)	Anticipated requirement during construction m ³ /a
Remaining Extent of Farm Bas Berg No. 88 (Two Sections)	770	(75%) of 9000 m ³ /a	50% of 9000 m ³ /a											34 650	11 250
Remaining Extent of Portion 3 of the Farm Bas Berg No. 88	7687	25% of 9000 m ³ /a	50% of 9000 m ³ /a	100% of 9000 m ³ /a	100% of 9000 m ³ /a	100% of 18000 m ³ /a								40 000	42 750
Remaining extent of Portion 2 (Middel Plaats) (a portion of Portion 1) of the farm Grasspan No. 40	1054						100% of 9000 m ³ /a	100% of 18000 m ³ /a						40 000	27 000
Portion 1 (Wolve Kuil West) of the farm Annex Wolve Kuil No. 41	1707								75% of 18000 m ³ /a	100% of 9000 m ³ /a	100% of 9000 m ³ /a	75% of 18000 m ³ /a		40 000	45 000
Remaining extent of the farm Annex Wolve Kuil No. 41	1128								25% of 18000 m ³ /a					40 000	4 500
Portion 2 of the farm Wolve Kuil No. 43	1238											25% of 18000 m ³ /a	100% of 9000 m ³ /a	40 000	13 500
Total														234 650	144 000

16.9 Environmental Management Programme Inputs

Potential environmental impacts pertaining to local groundwater resources have been considered in this EIA. In order to ensure safe and sustainable management of the groundwater resources in the area, several management inputs will be required. These inputs are, however, not required as part of the EIA phase and will only be required once the final operational conditions of the project are confirmed post environmental authorisation. Phase 1 will be required to determine if the groundwater is of a suitable quality and quantity; and Phase 2 will only be required if the groundwater quality and quantity are confirmed suitable for use. Additional information is provided below.

Phase 1: Determining if the groundwater is of a suitable quality and quantity:

1. Undertake a full laboratory analysis to confirm that the groundwater can be used for potable and domestic purposes, and determine the treatment required. This Geohydrology Assessment has confirmed that the groundwater is generally of good quality in terms of pH, EC and TDS.
2. The water quality is not considered suitable for panel washing as it will result in salts precipitating on the panels. The salts could be removed from the groundwater by thermal distillation (i.e. boiling since salt has a much higher boiling point than water) or by membrane separation (commonly reverse osmosis). Confirm what mechanisms could be used to remove the salts from the groundwater for panel cleaning. This will entail undertaking a financial viability investigation / feasibility study.
3. Undertake necessary tests to confirm if the groundwater is suitable for construction and concrete batching.
4. Conduct scientific yield tests to determine sustainable abstraction volumes from boreholes that are to be utilised.

Phase 2: Once the groundwater quality and quantity are determined more accurately and confirmed it is suitable for use the follow steps are required for sustainable management:

1. Acquire any historical monitoring data for the region.
2. Determine the volume of groundwater abstracted by farmers annually prior to construction by flow meters.
3. Ensure water saving techniques are instated and adhered to.
4. Ensure that proper bunding and secondary containment measures are in place for BESS facilities and are designed by an appropriate competent person.
5. Ensure that environmentally safe cleaning agents that breakdown naturally and do not cause adverse effects are used.
6. In the event that the entire Kudu Solar Facility development is constructed simultaneously, adherence to the recommended mitigation measures should be strictly followed to prevent over-abstraction.
7. Instate an appropriate monitoring program including monitoring of groundwater quality, water levels (ideally by water level loggers and hand readings using a dip meter), and abstracted volumes. These data should be reported on at the least biannually.

8. Yield test all monitoring boreholes according to SANS 10299-4:2003, Part 4 – Test pumping of water boreholes. This includes a Step Test, Constant Discharge Test and recovery monitoring.

16.9.1 Proposed Monitoring Plan:

It is recommended that at least three boreholes in the vicinity of each cluster of projects be allocated for monitoring purposes. These can either be existing boreholes, or newly drilled monitoring boreholes as this will allow for monitoring of the groundwater quality and groundwater levels across the affected area. The optimum position of the monitoring boreholes should be based on availability of open space surrounding the planned buildable area; however, it is recommended that one borehole be located up-gradient of the affected area to monitor background values and the other two boreholes be down-gradient of the affected area. Three general monitoring sites are presented in Table 16-17, however these are in an idealised scenario and any existing boreholes in the vicinity of the proposed sites can be utilised for monitoring purposes. Furthermore, one or more monitoring boreholes should present within 100 meters of notable contamination points (i.e. BESS and refuelling stations) as well as near project specific groundwater abstraction points. The borehole water level (if present) and the groundwater quality should be monitored on a monthly basis during construction phase and then on a quarterly basis during operational phase, so as to determine seasonal fluctuation. The implementation of the groundwater monitoring programme will be important for assessing any impacts of the Kudu Solar Facility on groundwater and the environment.

It is recommended that groundwater monitoring be undertaken at the proposed site in accordance with guidelines set out in the publication by DWAF (1998). The various aspects of the monitoring are presented in this section, along with relevant recommendations.

Table 16-17: General locations for proposed monitoring points.

Site_ID	Latitude (DD, WGS84)	Longitude (DD, WGS84)
K1M_04	-30,200186	24,339737
K1M_05	-30,206171	24,312882
K1M_06	-30,194222	24,279089

In the case that new monitoring boreholes are drilled, the drilling should be supervised by a geohydrologist and drill samples should be collected every 1 metre and logged. Additional information should also be collected such as the depth of water strikes, associated water strike yields and groundwater quality. This is crucial information for the optimal design of the boreholes. The driller should be supervised to ensure all site requirements are met. A graphical representation of a proposed borehole construction is presented in Figure 16-4; the exact construction will, however, be unique for the borehole. It is not anticipated that multiple aquifers will be present in the bedrock. The inner diameter of the uPVC casing must not be less than 110 mm.

A gravel pack should be installed with an annulus of about 12 mm. The boreholes should be developed with compressed air for at least two hours upon completion along with an airlift test to

estimate the yield of the borehole. Each borehole must be protected with a concrete block or a protected manhole if there is traffic in the area. Each borehole also needs a permanent plate glued to the lid containing the details pertaining to the borehole. A bentonite plug of at least 500 mm needs to be installed at the top of the hole to prevent ingress of surface water.

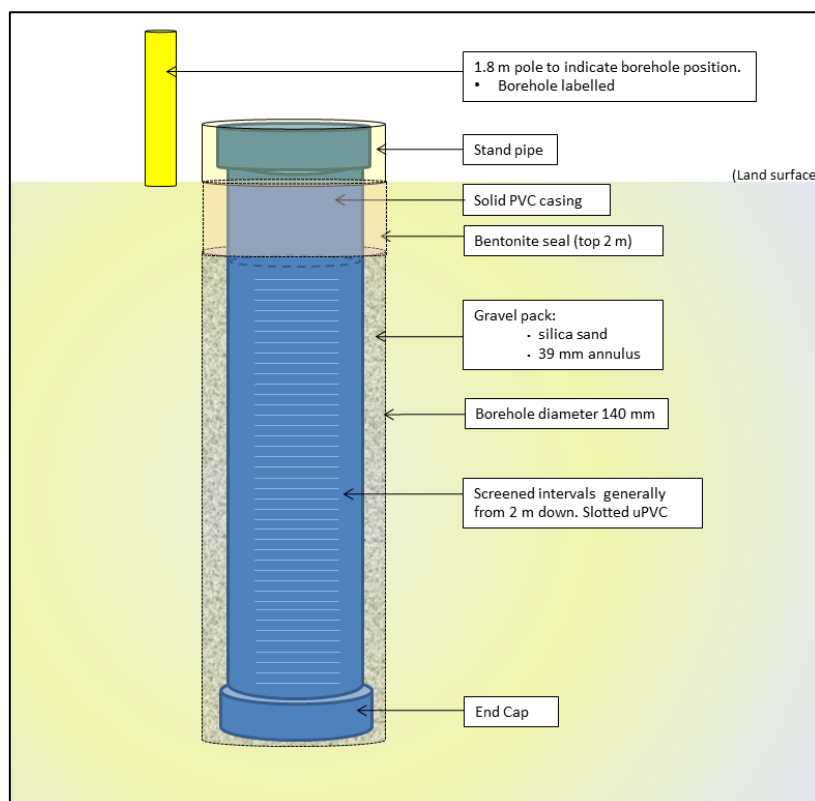

Figure 16-4: Schematic representation of the proposed general borehole construction.

16.9.1.1 Groundwater Level Monitoring

Groundwater level measurements are recommended for the monitoring boreholes at the study site. A dip meter can be used to measure the water level below the top of the borehole collar/casing height (mbch). The height of the collar/casing height must then also be measured (m). The water level (metres below ground level (mbgl)) can then be calculated by subtracting the collar/casing height from the water level (mbch). The value must be recorded along with the date and time of measurement. An interface meter can be used during monitoring to detect the presence of non-aqueous phase liquids (if present).

16.9.1.2 Groundwater Quality Monitoring

It is preferable to use a low volume sampling pump in most monitoring boreholes. Prior to sampling, the groundwater should be pumped through a flow-through cell until field chemistry parameters have stabilised.

16.9.1.3 Sample Collection, Preservation and Submission

Sample bottles must be labelled with the site name, borehole name and date. At the time of sampling, field chemistry parameters must be measured and recorded. These include electrical conductivity (EC), oxidation reduction potential (ORP), pH, temperature and dissolved oxygen (DO). During sampling, disposable nitrile gloves should be worn to minimise the transfer of any potential contaminants. Nitrile gloves should be dedicated to a sampling location and disposed of after use. Samples must be collected in an appropriate sampling container and preserved in the correct manner prior to submission to an accredited laboratory for the analysis parameters. The sample method and preservation must be discussed with the laboratory prior to sampling.

16.9.1.4 Monitoring Frequency and Parameter Analysis

In order to best understand and monitor the site, it is recommended that monthly water level measurements be taken to determine seasonal fluctuation during the construction period, after which water level measurements can be taken at quarterly intervals during the operational phase. Further to this, water quality measurements should be taken on a quarterly basis during the construction phase, after which water quality measurement can be taken on a bi-annual basis during the operational phase. The monitoring schedule can be reviewed and revised upon the start of the decommissioning phase. Table 16-18 indicates the potential parameters for the analysis.

Table 16-18: Proposed groundwater monitoring parameters and their recommended frequency.

Parameter	Frequency		
	K1M_04	K1M_05	K1M_06
Groundwater Level	Monthly (Construction Phase) Quarterly (Operational Phase)	Monthly (Construction Phase) Quarterly (Operational Phase)	Monthly (Construction Phase) Quarterly (Operational Phase)
pH	Quarterly (Construction Phase) Bi-annually (Operational Phase)	Quarterly (Construction Phase) Bi-annually (Operational Phase)	Quarterly (Construction Phase) Bi-annually (Operational Phase)
Electrical conductivity (EC)	Quarterly (Construction Phase) Bi-annually (Operational Phase)	Quarterly (Construction Phase) Bi-annually (Operational Phase)	Quarterly (Construction Phase) Bi-annually (Operational Phase)
Total Dissolved Solids (TDS)	Quarterly (Construction Phase) Bi-annually (Operational Phase)	Quarterly (Construction Phase) Bi-annually (Operational Phase)	Quarterly (Construction Phase) Bi-annually (Operational Phase)
Alkalinity	Quarterly (Construction Phase) Bi-annually (Operational Phase)	Quarterly (Construction Phase) Bi-annually (Operational Phase)	Quarterly (Construction Phase) Bi-annually (Operational Phase)
Total Organic Carbon (TOC)	Quarterly (Construction Phase) Bi-annually (Operational Phase)	Quarterly (Construction Phase) Bi-annually (Operational Phase)	Quarterly (Construction Phase) Bi-annually (Operational Phase)
Benzene	Quarterly (Construction Phase) Bi-annually (Operational Phase)	Quarterly (Construction Phase) Bi-annually (Operational Phase)	Quarterly (Construction Phase) Bi-annually (Operational Phase)
Toulene	Quarterly (Construction Phase) Bi-annually (Operational Phase)	Quarterly (Construction Phase) Bi-annually (Operational Phase)	Quarterly (Construction Phase) Bi-annually (Operational Phase)
Ethylene	Quarterly (Construction Phase) Bi-annually (Operational Phase)	Quarterly (Construction Phase) Bi-annually (Operational Phase)	Quarterly (Construction Phase) Bi-annually (Operational Phase)
Xylene	Quarterly (Construction Phase)	Quarterly (Construction Phase)	Quarterly (Construction Phase)

Parameter	Frequency		
	K1M_04	K1M_05	K1M_06
	Bi-annually (Operational Phase)	Bi-annually (Operational Phase)	Bi-annually (Operational Phase)
Gasoline Range Organics (GRO)	Quarterly (Construction Phase) Bi-annually (Operational Phase)	Quarterly (Construction Phase) Bi-annually (Operational Phase)	Quarterly (Construction Phase) Bi-annually (Operational Phase)
Extractible Petroleum Hydrocarbons (EPH)	Quarterly (Construction Phase) Bi-annually (Operational Phase)	Quarterly (Construction Phase) Bi-annually (Operational Phase)	Quarterly (Construction Phase) Bi-annually (Operational Phase)
Volatile Organic Compounds (VOC)	Quarterly (Construction Phase) Bi-annually (Operational Phase)	Quarterly (Construction Phase) Bi-annually (Operational Phase)	Quarterly (Construction Phase) Bi-annually (Operational Phase)
Cd	Quarterly (Construction Phase) Bi-annually (Operational Phase)	Quarterly (Construction Phase) Bi-annually (Operational Phase)	Quarterly (Construction Phase) Bi-annually (Operational Phase)
Cr	Quarterly (Construction Phase) Bi-annually (Operational Phase)	Quarterly (Construction Phase) Bi-annually (Operational Phase)	Quarterly (Construction Phase) Bi-annually (Operational Phase)
Cu	Quarterly (Construction Phase) Bi-annually (Operational Phase)	Quarterly (Construction Phase) Bi-annually (Operational Phase)	Quarterly (Construction Phase) Bi-annually (Operational Phase)
Fe	Quarterly (Construction Phase) Bi-annually (Operational Phase)	Quarterly (Construction Phase) Bi-annually (Operational Phase)	Quarterly (Construction Phase) Bi-annually (Operational Phase)
Ni	Quarterly (Construction Phase) Bi-annually (Operational Phase)	Quarterly (Construction Phase) Bi-annually (Operational Phase)	Quarterly (Construction Phase) Bi-annually (Operational Phase)
Zn	Quarterly (Construction Phase) Bi-annually (Operational Phase)	Quarterly (Construction Phase) Bi-annually (Operational Phase)	Quarterly (Construction Phase) Bi-annually (Operational Phase)
V	Quarterly (Construction Phase) Bi-annually (Operational Phase)	Quarterly (Construction Phase) Bi-annually (Operational Phase)	Quarterly (Construction Phase) Bi-annually (Operational Phase)

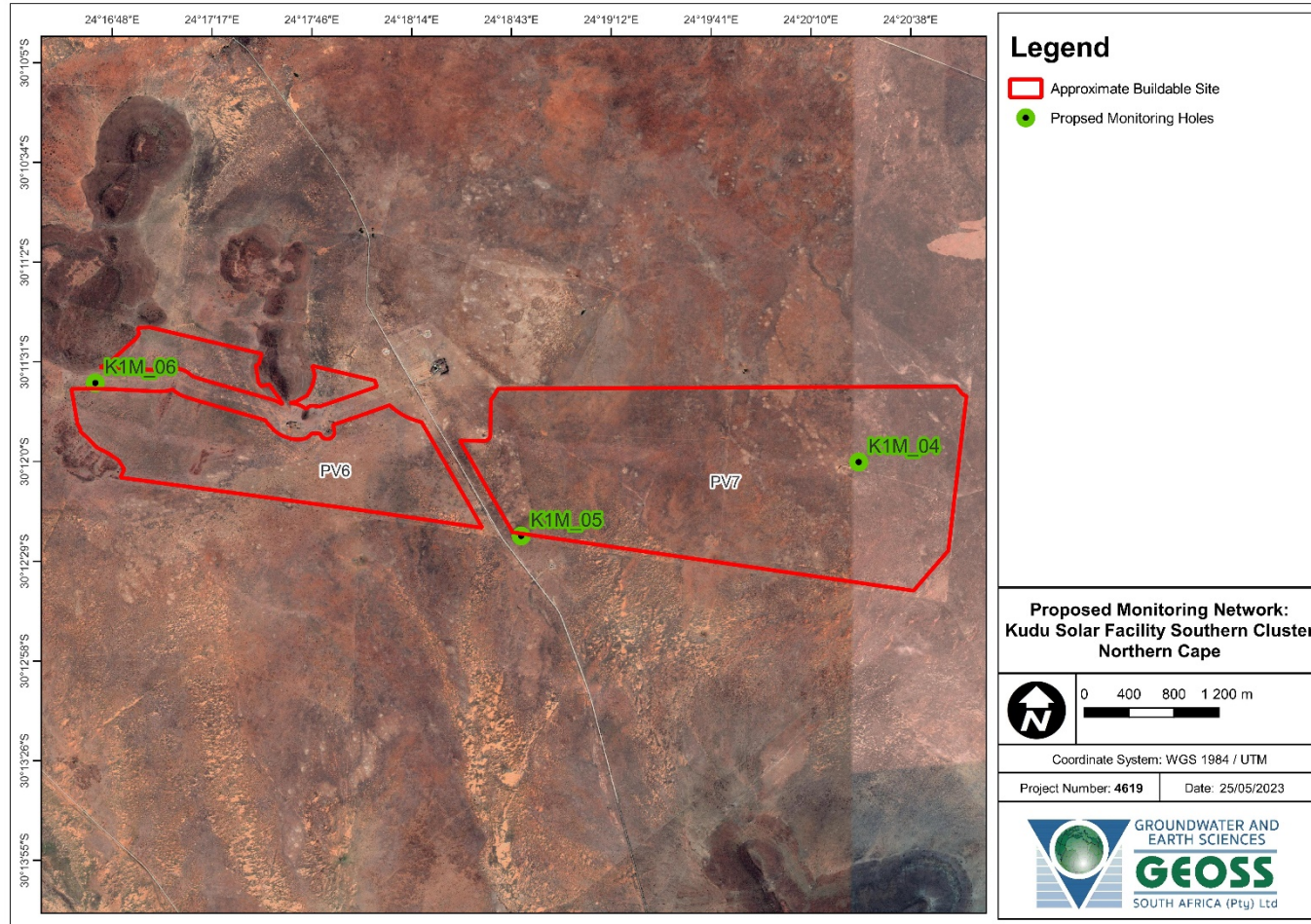

Map 16-11: Proposed monitoring borehole locations from an aerial view.

16.10 Final Specialist Statement and Authorisation Recommendation

16.10.1 Statement and Reasoned Opinion

The Geohydrology Assessment conducted for the Kudu Solar PV7 facility came to the following main conclusions:

- The anticipated demands of this facility are less than the regional yield potential of the underlying aquifer (0.5 – 2.0 L/s).
- HBH18, HBH19, and HBH20 are potentially viable sources of groundwater for the development of Solar Facility 7. The use of this/these borehole/s would/will depend on the operational requirements of the facility, negotiations with the landowners and proximity to the facility.
- The demand for the facility could potentially be met by abstraction from Remaining Extent of Portion 2 (Middle Plaats) (a portion of Portion 1) of the Farm Grasspan No. 40 under General Authorisation. This holds true even if Solar Facilities 6 and 7 are constructed simultaneously. However, if all the Kudu Soila Facilities are constructed at the same time, cumulatively, the water demands during the construction period will exceed the available GA volume of the farm portion. Therefore, groundwater exploration (including hydrocensus, lineament mapping and geophysics) on adjacent properties should be undertaken for additional supply to meet the demands. Alternatively, to source all the water from this farm portion, a Water Use License Application will be required to meet the demands of the construction period.
- The cumulative demands of construction (~4.6 L/s) for all twelve planned Kudu Solar Facilities (if developed simultaneously) exceeds the regional yield potential of the underlying aquifer (0.5 – 2.0 L/s). Since yield information was not available during the undertaking of the hydrocensus, estimations for groundwater supply capacity for the area are based on regional datasets.
- The study site has been classified as overlying low yielding aquifer with a groundwater vulnerability classification of “low/medium” to medium and a sensitivity rating of “medium” with no areas that need to be avoided.
- Both the potential individual and cumulative impacts from the construction, operation, and decommissioning phases for of the development are considered as Low to Very Low with appropriate mitigation.

Given these conclusions it is the opinion of the specialist that development of the proposed Kudu Solar Facility be authorised to proceed given that proper mitigation measures highlighted within this document are implemented during each phase of the project to suppress the intensity of identified impacts.

16.10.2 EA Condition Recommendations

From the impact assessment it is evident that the development will have a very low to low impact on the local geohydrological system as long as the recommended mitigation measures are adhered to. As such, the project is authorised to continue from a geohydrological perspective on condition of implementation of the following recommendations:

- In the case that multiple projects are constructed simultaneously, adherence to recommended mitigation measures should be strictly followed to prevent over abstraction.
- Phase two of the monitoring plan is to be discussed and evaluated in the event that groundwater is to be used in the project.
- The proposed monitoring plan should be followed with a special focus on groundwater level monitoring to ensure that the aquifer is not over abstracted and falls to levels below historic borehole depths.
- All proposed impact mitigation measures are to be implemented during the development of the project. These include the use of environmentally safe cleaning agents, the construction of BESS facilities 50m from any boreholes along with appropriate bunding and secondary containment, and the recommended precautionary approaches aimed at preventing oil spills and fuel leaks.

16.11 References

- Aller L., Bennet T., Lehr J.H. and Petty R.J. (1987). DRASTIC – A standardised system for evaluating groundwater pollution potential using hydrogeological setting. US EPA Report EPA/600/2-87/035, United States Environmental Protection Agency.
- CGS (2009). The 1:1 000 000 geological map series of South Africa. Council for Geoscience. South Africa
- Conrad J. and Munch Z., (2007). Groundwater recharge and vulnerability mapping – a national scale approach; GWD Conference Bloemfontein, 8 – 10 October 2007 pp 46 – 56.
- Department of Environment, Forestry and Fisheries, 2019. Strategic Environmental Assessment for the Expansion of Electricity Grid Infrastructure Corridors in South Africa. CSIR Report Number: CSIR/SPLA/EMS/ER/2019/0076/B. ISBN Number: ISBN 978-0-7988-5648-5. Stellenbosch and Durban
- DWAF (1998). Quality of domestic water supplies, Volume 1: Assessment guide. Department of Water Affairs and Forestry, Department of Health, Water Research Commission, 1998.
- DWAF (2002). 1:500 000 Hydrogeological map series of the republic of South Africa. Cape Town, 3318.
- DWAF (2005). Groundwater Resource Assessment – Phase II (GRAII). Department of Water Affairs and Forestry. Pretoria.
- Freeze, R.A., and Cherry, J.A., (1979), Groundwater: Englewood Cliffs, NJ, Prentice-Hall.
- GEOSS (2015). Consulting report from a neighbouring property. GEOSS Report Number: 2015/11-04. GEOSS - Geohydrological & Spatial Solutions International (Pty) Ltd. Stellenbosch, South Africa.
- Harkness, J.S., Swana, K., Eymold, W.K., Miller, J., Murray, R., Talma, S., Whyte, C.J., Moore, M.T., Maletic, E.L., Vengosh, A. and Darrah, T.H., 2018. Pre-drill groundwater geochemistry in the Karoo Basin, South Africa.
- <https://gis.elsenburg.com/apps/cfm/>. A website that provides GIS based information on climate, geology, vegetation and conservation.
- Johnson M., Van Vuuren C., Visser J., Cole D., Wickens H., Christie A., Roberts D., Brandl G. (2006) Sedimentary Rocks of the Karoo Supergroup In (Eds) Johnson, M.R., Anhaeuser, C.R. and Thomas, R.J. The Geology of South Africa. Geological Society of South Africa, Johannesburg
- National Research Council (1993). Ground water vulnerability assessment, contamination potential under conditions of uncertainty: National Academy Press, Washington, D.C., 210 p. Accessed December 2000 at URL <http://books.nap.edu/books/0309047994/html>.
- National Water Act (1998). The National Water Act, Act 36 of 1998. Department of Water Affairs and Forestry. Pretoria.
- Parsons R., and Conrad, J., (1993). South African aquifer system management classification'; WRC Report No: KV 77/95; Author: Mr. Parsons R; Date Published: 12 January 1993.

Schulze, R. E., 2009. SA Atlas of Climatology and Geohydrology; obtained from Western Cape Government Agriculture - <http://gis.elsenburg.com/apps/cfm/>: Long term median rainfall per month (1950-2000).

Senger, K., Buckley, S.J., Chevallier, L., Fagereng, Å., Galland, O., Kurz, T.H., Ogata, K., Planke, S. and Tveranger, J., 2015. Fracturing of doleritic intrusions and associated contact zones: Implications for fluid flow in volcanic basins. *Journal of African Earth Sciences*, 102, pp.70-85.

Vrba, J. and A. Zaporozec (eds.) 1994. *Guidebook on Mapping Groundwater Vulnerability*. Verlag Heinz Heise, Hannover, Germany, International Contributions to Hydrogeology, Vol. 16, 131 pp. Conrad and Munch, 2007

WRC, 2012. *A Groundwater Planning Toolkit for the Main Karoo Basin: Identifying and quantifying groundwater development options incorporating the concept of wellfield yields and aquifer firm yields*. WRC Report No. 1763/1/11, Pretoria, South Africa.

APPENDICES

APPENDIX A - SPECIALIST EXPERTISE

CURRICULUM VITAE – LOUIS JONK

GENERAL

<i>Nationality:</i>	South African
<i>Profession:</i>	Geotechnical Specialist
<i>Specialization:</i>	Soil classification for engineering purposes. Groundwater exploration and sampling.
<i>Position in firm:</i>	Geotechnical Geologist at GEOSS – South Africa (Pty) Ltd.
<i>Date commenced:</i>	09 January 2023
<i>Year of birth & ID #:</i>	1993 – 9307215060088
<i>Language skills:</i>	English (good – speaking, reading, and writing) Afrikaans (good - speaking, reading, and writing).

KEY SKILLS

- Geotechnical investigations
- Compilation of factual reports.
- Field mapping.
- Soil and rock profiling.
- Material classification and material use determination.
- Supervision of geotechnical contractors.
- ArcGIS, QGIS, Python, FLAC/SLOPE; HotPlot

EDUCATIONAL AND PROFESSIONAL STATUS

Qualifications

2018	M.Sc. (Geology – Cum Laude)	University of the Stellenbosch, South Africa
2015	B.Sc. Hons. (Earth Science)	University of the Stellenbosch, South Africa
2014	B.Sc. (Geology: Earth Science)	University of the Stellenbosch, South Africa

EMPLOYMENT RECORD

Jan 2023 to present	GEOSS South Africa (Pty) Ltd, South Africa
April 2020 to Dec 2022	Council for Geoscience South Africa
April 2018 to March 2020	Iziko Museums of South Africa

CURRICULUM VITAE – SHANE TEEK

GENERAL

Nationality: South African
Profession: Geotechnical Specialist & Hydrogeologist
Specialization: Soil classification for engineering purposes. Groundwater exploration and sampling.
Position in firm: Geotechnical Geologist & Hydrogeologist at GEOSS – South Africa (Pty) Ltd.
Date commenced: 17 July 2021
Year of birth & ID #: 1994 – 9404135162084
Language skills: English (good – speaking, reading, and writing)
Afrikaans (good - speaking, reading, and writing).

KEY SKILLS

- Geotechnical investigations
- Compilation of factual reports.
- Field mapping.
- Soil and rock profiling.
- Material classification and material use determination.
- Supervision of geotechnical contractors.
- Groundwater geophysics and conducting hydrocensus studies.
- Groundwater development - borehole drilling and test pumping supervision and analysis.
- Groundwater monitoring - development and analysis of groundwater level and quality data.
- Groundwater management - sustainable aquifer development and management.
- Groundwater contamination assessments.
- ArcGIS, QGIS, Python, FLAC/SLOPE, Midas GTS NX.

EDUCATIONAL AND PROFESSIONAL STATUS

Qualifications

2021	M.Eng. (Civil Engineering – Cum Laude)	University of the Stellenbosch, South Africa
2016	B.Sc. Hons. (Earth Science)	University of the Stellenbosch, South Africa
2015	B.Sc. (Geology: Earth Science)	University of the Stellenbosch, South Africa

Memberships

- Geological Society of South Africa – Member No. 970413
- South African Council for National Scientific Professions (SACNASP) Mem. No. 126397/20
- Founding member of the UNESCO Groundwater Youth Network (GWYN)

EMPLOYMENT RECORD

July 2021 to present	GEOSS South Africa (Pty) Ltd, South Africa
Jan 2020 to June 2021	Geotechnics Africa Western Cape, South Africa
Feb 2019 to July 2019	Polytechnique Montréal, Canada
Jan 2017 to Dec 2017	Remote Exploration Services, South Africa.

CURRICULUM VITAE – DALE BARROW

GENERAL

Nationality: South African
Profession: Hydrogeologist
Firm: GEOSS South Africa (Pty) Ltd
Position: Director and Hydrogeologist
Specialization: Groundwater exploration, development, management and monitoring including numerical modelling. Hydrogeological impact studies and assessment of groundwater – surface water interaction.
Date commenced: February 2008
Year of birth & ID #: 1985 – 851205 5227 082
Language skills: English (mother tongue), Afrikaans (average)

KEY SKILLS

- Project Management
- Hydrogeological technical input on projects
- Groundwater surface water interaction assessment
- Groundwater exploration - (aerial photo interpretation, resistivity, magnetic and EM34 geophysical surveys for borehole siting purposes, geological conceptualization)
- Groundwater development - borehole drilling and test pumping supervision and analysis.
- Groundwater monitoring –development and analysis of groundwater level and quality data.
- Groundwater management – sustainable aquifer development and management.
- Numerical modelling of groundwater flow and mass transport.
- Groundwater component of Catchment Management Strategies and other Groundwater Resource Directed Measures.
- Groundwater contamination assessments.
- GIS / WISH and GW Vistas and typical software skills.

EDUCATIONAL AND PROFESSIONAL STATUS

Qualifications

2017	MBA (Cum Laude)	University of Stellenbosch, South Africa
2010	M.Sc. (Geohydrology)	University of the Free State, South Africa
2007	B.Sc. (Hons) Structural Geology	University of Stellenbosch, South Africa
2006	B.Sc. Geology – Applied Earth Science	University of Stellenbosch, South Africa

Courses

2019	Water Governance in South Africa: IWRM, the NWA, and water use authorizations, focusing on WULAs and IWWMPs. WISA accredited. Carin Bosman (CBSS)
2016	SPRING Software Modelling Course
2015	European Management Residency in Economics and Business (Maastricht University School of Business and Economics)
2013	Aquifer Firm Yield; Wellfield Design; Wellfield costing
2010	Introduction to QGIS (GISSA)
2010	Presentation Skills (Elsabé Daneel productions cc)
2009	Introduction to Isotope Hydrology in Southern Africa (GSSA)
2009	Aquifer Mechanics (IGS-UOFS)

2009 Groundwater Chemistry (IGS-UOFS)
2009 Groundwater Geophysics (IGS-UOFS)
2009 Groundwater Modelling (IGS-UOFS)
2009 Groundwater Management (IGS-UOFS)

Memberships

- Groundwater Division of the Geological Society of South Africa
- South African Council for National Scientific Professions (SACNASP) Mem. No. 400289/13

EMPLOYMENT RECORD

1 February 2008 to present: GEOSS – Geohydrological and Spatial Solutions International (Pty) Ltd, Stellenbosch
23 July 2018 - November 2019 Design and part time lecturing of the Hydrogeology course for 3rd year students at Stellenbosch University

APPENDIX B - SPECIALIST STATEMENT OF INDEPENDENCE



environmental affairs

Department:
Environmental Affairs
REPUBLIC OF SOUTH AFRICA

DETAILS OF THE SPECIALIST, DECLARATION OF INTEREST AND UNDERTAKING UNDER OATH

File Reference Number:	(For official use only)
NEAS Reference Number:	DEA/EIA/
Date Received:	

Application for authorisation in terms of the National Environmental Management Act, Act No. 107 of 1998, as amended and the Environmental Impact Assessment (EIA) Regulations, 2014, as amended (the Regulations)

PROJECT TITLE

Scoping and Environmental Impact Assessment Processes for the Proposed Development of 12 Solar Photovoltaic (PV) Facilities and associated infrastructure (i.e. Kudu Solar Facility 1 - 12), near De Aar, Northern Cape

Kindly note the following:

1. This form must always be used for applications that must be subjected to Basic Assessment or Scoping & Environmental Impact Reporting where this Department is the Competent Authority.
2. This form is current as of 01 September 2018. It is the responsibility of the Applicant / Environmental Assessment Practitioner (EAP) to ascertain whether subsequent versions of the form have been published or produced by the Competent Authority. The latest available Departmental templates are available at <https://www.environment.gov.za/documents/forms>.
3. A copy of this form containing original signatures must be appended to all Draft and Final Reports submitted to the department for consideration.
4. All documentation delivered to the physical address contained in this form must be delivered during the official Departmental Officer Hours which is visible on the Departmental gate.
5. All EIA related documents (includes application forms, reports or any EIA related submissions) that are faxed; emailed; delivered to Security or placed in the Departmental Tender Box will not be accepted, only hardcopy submissions are accepted.

Departmental Details

Postal address:
Department of Environmental Affairs
Attention: Chief Director: Integrated Environmental Authorisations
Private Bag X447
Pretoria
0001

Physical address:
Department of Environmental Affairs
Attention: Chief Director: Integrated Environmental Authorisations
Environment House
473 Steve Biko Road
Arcadia

Queries must be directed to the Directorate: Coordination, Strategic Planning and Support at:
Email: EIAAdmin@environment.gov.za

1. SPECIALIST INFORMATION

Specialist Company Name:	GEOSS SOUTH AFRICA (PTY) LTD		
B-BBEE	Contribution level (Indicate 1 to 8 or non-compliant)	3	Percentage Procurement recognition
			110%
Specialist name:	SHANE TEEK		
Specialist Qualifications:	MEng – Civil Engineering		
Professional affiliation/registration:	SACNASP: 126397		
Physical address:	Unit 12, Techno Steil Bldg, 09 Quantum Street, Techno Park, Stellenbosch		
Postal address:	PO Bo12412, Die Boord, Stellenbosch		
Postal code:	7613	Cell:	079 183 7782
Telephone:	021 880 1079	Fax:	n/a
E-mail:			

2. DECLARATION BY THE SPECIALIST

I, **SHANE TEEK**, declare that –

- I act as the independent specialist in this application;
- I will perform the work relating to the application in an objective manner, even if this results in views and findings that are not favourable to the applicant;
- I declare that there are no circumstances that may compromise my objectivity in performing such work;
- I have expertise in conducting the specialist report relevant to this application, including knowledge of the Act, Regulations and any guidelines that have relevance to the proposed activity;
- I will comply with the Act, Regulations and all other applicable legislation;
- I have no, and will not engage in, conflicting interests in the undertaking of the activity;
- I undertake to disclose to the applicant and the competent authority all material information in my possession that reasonably has or may have the potential of influencing - any decision to be taken with respect to the application by the competent authority; and - the objectivity of any report, plan or document to be prepared by myself for submission to the competent authority;
- all the particulars furnished by me in this form are true and correct; and
- I realise that a false declaration is an offence in terms of regulation 48 and is punishable in terms of section 24F of the Act.



Signature of the Specialist

GEOSS SOUTH AFRICA (PTY) LTD

Name of Company:

28 November 2022

Date

Details of Specialist, Declaration and Undertaking Under Oath

3. UNDERTAKING UNDER OATH/ AFFIRMATION

I, SHANE TEEK, swear under oath / affirm that all the information submitted or to be submitted for the purposes of this application is true and correct.



Signature of the Specialist

GEOSS SOUTH AFRICA (PTY) LTD

Name of Company

28 November 2022

Date

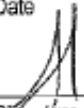

Samantha Schoeman
ACMA 1-7 Puumen
17 Schoongeleen Ste, Helderberg, 7130

Signature of the Commissioner of Oaths

29/11/2022

Date

ENVIRONMENTAL IMPACT ASSESSMENT REPORT: Scoping and Environmental Impact Assessment (EIA)
Process for the Proposed Development of a Solar Photovoltaic (PV) Facility (Kudu Solar Facility 7) and
associated infrastructure, near De Aar, Northern Cape Province



environmental affairs

Department:
Environmental Affairs
REPUBLIC OF SOUTH AFRICA

DETAILS OF THE SPECIALIST, DECLARATION OF INTEREST AND UNDERTAKING UNDER OATH

File Reference Number:	(For official use only)
NEAS Reference Number:	DEA/EIA/
Date Received:	

Application for authorisation in terms of the National Environmental Management Act, Act No. 107 of 1998, as amended and the Environmental Impact Assessment (EIA) Regulations, 2014, as amended (the Regulations)

PROJECT TITLE

Scoping and Environmental Impact Assessment Processes for the Proposed Development of 12 Solar Photovoltaic (PV) Facilities and associated infrastructure (i.e. Kudu Solar Facility 1 - 12), near De Aar, Northern Cape

Kindly note the following:

1. This form must always be used for applications that must be subjected to Basic Assessment or Scoping & Environmental Impact Reporting where this Department is the Competent Authority.
2. This form is current as of 01 September 2018. It is the responsibility of the Applicant / Environmental Assessment Practitioner (EAP) to ascertain whether subsequent versions of the form have been published or produced by the Competent Authority. The latest available Departmental templates are available at <https://www.environment.gov.za/documents/forms>.
3. A copy of this form containing original signatures must be appended to all Draft and Final Reports submitted to the department for consideration.
4. All documentation delivered to the physical address contained in this form must be delivered during the official Departmental Officer Hours which is visible on the Departmental gate.
5. All EIA related documents (includes application forms, reports or any EIA related submissions) that are faxed; emailed; delivered to Security or placed in the Departmental Tender Box will not be accepted, only hardcopy submissions are accepted.

Departmental Details

Postal address:

Department of Environmental Affairs
Attention: Chief Director: Integrated Environmental Authorisations
Private Bag X447
Pretoria
0001

Physical address:

Department of Environmental Affairs
Attention: Chief Director: Integrated Environmental Authorisations
Environment House
473 Steve Biko Road
Arcadia

Queries must be directed to the Directorate: Coordination, Strategic Planning and Support at:
Email: EIAAdmin@environment.gov.za

ENVIRONMENTAL IMPACT ASSESSMENT REPORT: Scoping and Environmental Impact Assessment (EIA)
Process for the Proposed Development of a Solar Photovoltaic (PV) Facility (Kudu Solar Facility 7) and
associated infrastructure, near De Aar, Northern Cape Province

1. SPECIALIST INFORMATION

Specialist Company Name:	GEOSS SOUTH AFRICA (PTY) LTD		
B-BBEE:	Contribution level (Indicate 1 to 8 or non-compliant)	3	Percentage Procurement recognition
			110%
Specialist name:	DALE BARROW		
Specialist Qualifications:	MSc in Hydrogeology		
Professional affiliation/registration:	SACNASP: 400289/13		
Physical address:	Unit 12, Techno Stell Bldg, 09 Quantum Street, Techno Park, Stellenbosch		
Postal address:	PO Box 12412, Die Boord, Stellenbosch		
Postal code:	7613	Cell:	074 172 2862
Telephone:	021 880 1079	Fax:	n/a
E-mail:	dbarrow@geoss.co.za		

2. DECLARATION BY THE SPECIALIST

I, Dale Barrow, declare that –

- I act as the independent specialist in this application;
- I will perform the work relating to the application in an objective manner, even if this results in views and findings that are not favourable to the applicant;
- I declare that there are no circumstances that may compromise my objectivity in performing such work;
- I have expertise in conducting the specialist report relevant to this application, including knowledge of the Act, Regulations and any guidelines that have relevance to the proposed activity;
- I will comply with the Act, Regulations and all other applicable legislation;
- I have no, and will not engage in, conflicting interests in the undertaking of the activity;
- I undertake to disclose to the applicant and the competent authority all material information in my possession that reasonably has or may have the potential of influencing - any decision to be taken with respect to the application by the competent authority; and - the objectivity of any report, plan or document to be prepared by myself for submission to the competent authority;
- all the particulars furnished by me in this form are true and correct; and
- I realise that a false declaration is an offence in terms of regulation 48 and is punishable in terms of section 24F of the Act.



Signature of the Specialist

GEOSS SOUTH AFRICA (PTY) LTD

Name of Company:

07 July 2023

Date

Details of Specialist, Declaration and Undertaking Under Oath

Page 2 of 3

3. UNDERTAKING UNDER OATH/ AFFIRMATION

I, Dale Barrow _____, swear under oath / affirm that all the information submitted or to be submitted for the purposes of this application is true and correct.



Signature of the Specialist

GEOSS SOUTH AFRICA (PTY) LTD

Name of Company

07 July 2023

Date



Signature of the Commissioner of Oaths

07 July 2023

Date

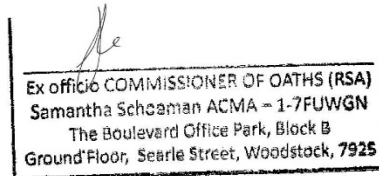



environmental affairs

Department:
Environmental Affairs
REPUBLIC OF SOUTH AFRICA

DETAILS OF THE SPECIALIST, DECLARATION OF INTEREST AND UNDERTAKING UNDER OATH

File Reference Number:	(For official use only)
NEAS Reference Number:	DEA/EIA/
Date Received:	

Application for authorisation in terms of the National Environmental Management Act, Act No. 107 of 1998, as amended and the Environmental Impact Assessment (EIA) Regulations, 2014, as amended (the Regulations)

PROJECT TITLE

Scoping and Environmental Impact Assessment Processes for the Proposed Development of 12 Solar Photovoltaic (PV) Facilities and associated infrastructure (i.e. Kudu Solar Facility 1 - 12), near De Aar, Northern Cape

Kindly note the following:

1. This form must always be used for applications that must be subjected to Basic Assessment or Scoping & Environmental Impact Reporting where this Department is the Competent Authority.
2. This form is current as of 01 September 2018. It is the responsibility of the Applicant / Environmental Assessment Practitioner (EAP) to ascertain whether subsequent versions of the form have been published or produced by the Competent Authority. The latest available Departmental templates are available at <https://www.environment.gov.za/documents/forms>.
3. A copy of this form containing original signatures must be appended to all Draft and Final Reports submitted to the department for consideration.
4. All documentation delivered to the physical address contained in this form must be delivered during the official Departmental Officer Hours which is visible on the Departmental gate.
5. All EIA related documents (includes application forms, reports or any EIA related submissions) that are faxed; emailed; delivered to Security or placed in the Departmental Tender Box will not be accepted, only hardcopy submissions are accepted.

Departmental Details

Postal address:

Department of Environmental Affairs
Attention: Chief Director: Integrated Environmental Authorisations
Private Bag X447
Pretoria
0001

Physical address:

Department of Environmental Affairs
Attention: Chief Director: Integrated Environmental Authorisations
Environment House
473 Steve Biko Road
Arcadia

Queries must be directed to the Directorate: Coordination, Strategic Planning and Support at:
Email: EIAAdmin@environment.gov.za

1. SPECIALIST INFORMATION

Specialist Company Name:	GEOSS South Africa (Pty) Ltd.		
B-BBEE	Contribution level (indicate 1 to 8 or non-compliant)	3	Percentage Procurement recognition
			110%
Specialist name:	Louis Jonk		
Specialist Qualifications:	B.Sc. (Hons) – Earth Sciences; M.Sc - Geology		
Professional affiliation/registration:	SACNASP 121278; GSSA 969970; PSSA		
Physical address:	Unit 12, Techno Stell Bldg, 09 Quantum Street, Techno Park, Stellenbosch		
Postal address:	PO Box 12412, Die Boord, Stellenbosch		
Postal code:	7613	Cell:	078 802 8447
Telephone:	021 880 1079	Fax:	n/a
E-mail:	ljonk@geoss.co.za		

2. DECLARATION BY THE SPECIALIST

I, **Louis Jonk**, declare that –

- I act as the independent specialist in this application;
- I will perform the work relating to the application in an objective manner, even if this results in views and findings that are not favourable to the applicant;
- I declare that there are no circumstances that may compromise my objectivity in performing such work;
- I have expertise in conducting the specialist report relevant to this application, including knowledge of the Act, Regulations and any guidelines that have relevance to the proposed activity;
- I will comply with the Act, Regulations and all other applicable legislation;
- I have no, and will not engage in, conflicting interests in the undertaking of the activity;
- I undertake to disclose to the applicant and the competent authority all material information in my possession that reasonably has or may have the potential of influencing - any decision to be taken with respect to the application by the competent authority; and - the objectivity of any report, plan or document to be prepared by myself for submission to the competent authority;
- all the particulars furnished by me in this form are true and correct; and
- I realise that a false declaration is an offence in terms of regulation 48 and is punishable in terms of section 24F of the Act.

 Signature of the Specialist

GEOSS SOUTH AFRICA (PTY) LTD
 Name of Company:

07 July 2023

Date

Details of Specialist, Declaration and Undertaking Under Oath

3. UNDERTAKING UNDER OATH/ AFFIRMATION

I, Louis Jonk, swear under oath / affirm that all the information submitted or to be submitted for the purposes of this application is true and correct.

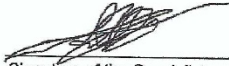

Signature of the Specialist

GEOSS SOUTH AFRICA (PTY) LTD

Name of Company

07 July 2023

Date



Signature of the Commissioner of Oaths

07 July 2023

Date

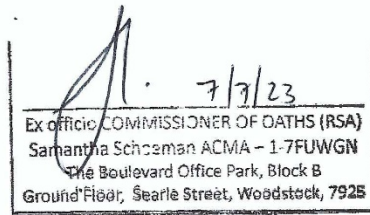

APPENDIX C - SITE SENSITIVITY VERIFICATION

Geohydrology themes do not exist on the National Web-based Environmental Screening Tool (Screening Tool) (as of May 2023); therefore, the environmental sensitivity of the proposed project area as identified by the Screening Tool is not applicable. For this reason, no site sensitivity verification report is required. Furthermore, there is no dedicated assessment protocol prescribed for conducting a Geohydrological Assessment. Therefore, this specialist assessment has been undertaken in compliance with Appendix 6 of the National Environmental Management Act (Act 107 of 1998, as amended) (NEMA) Environmental Impact Assessment (EIA) Regulations of 2014. Details of the site visit are indicated below:

Date of Site Visit	23-24 March 2022
Specialist Name	Christel van Staden and Dale Barrow
Professional Registration Number	Cand.Sci.Nat: 122591 and Pr.Sci.Nat: 400289/13
Specialist Affiliation / Company	GEOSS

All relevant desktop information, consultation with landowners, and previous assessments undertaken by the author in the study area have been taken into consideration during the undertaking of this specialist assessment.

The site sensitivity verification was undertaken using the following means:

- (a) desk top analysis, using satellite imagery; geological maps and hydrogeological and geotechnical reports and databases where possible and applicable.
- (b) preliminary on-site inspection; and drive over.
- (c) collected water samples, field chemistry and water levels where possible and relevant; assessed site conditions to determine whether literature information is generally confirmed.

APPENDIX D - IMPACT ASSESSMENT METHODOLOGY

The impact assessment includes:

- *the nature, status, significance and consequences of the impact and risk;*
- *the extent and duration of the impact and risk;*
- *the probability of the impact and risk occurring;*
- *the degree to which impacts and risks can be mitigated;*
- *the degree to which the impacts and risks can be reversed; and*
- *the degree to which the impacts and risks can cause loss of irreplaceable resources.*

Terminology used in impact assessment can overlap. To avoid ambiguity, please note the following clarifications (that are based on NEMA and the EIA Regulations):

- *The term environment is understood to have a broad interpretation that includes both the natural (biophysical) environment and the socio-economic environment. The term socio-ecological system is also used to describe the natural and socio-economic environment and the interactions amongst these components.*
- *Significance = Consequence x Probability, which means that significance is equivalent to risk.*
- *The impact can have a positive or negative status. The significance of a negative impact may be called a risk, and the significance of a positive impact may be called an opportunity.*

The following principles are to underpin the application of this methodology:

- *Transparent and repeatable process - specialists are to describe the thresholds and limits they apply in their assessment, wherever possible.*
- *Adapt parameters to context (where justified) – the methodology proposes some thresholds (e.g. for spatial extent, in Step 3 below), however, if the nature of the impact requires a different definition of the categories of spatial extent, then this can be provided and described.*
- *Combination of a quantitative and qualitative assessment – where possible, specialists are to provide quantitative assessments (e.g. areas of habitat affected, decibels of noise, number of jobs), however, it is recognised that not all impacts can be quantified, and then qualitative assessments are to be provided.*

As per the DFFE Guideline 5: Assessment of Alternatives and Impacts, the following methodology is applied to the prediction and assessment of impacts and risks. Potential impacts and risks have been rated in terms of the direct, indirect and cumulative:

- *Direct impacts are impacts that are caused directly by the activity and generally occur at the same time and at the place of the activity. These impacts are usually associated with the construction, operation or maintenance of an activity and are generally obvious and quantifiable.*
- *Indirect impacts of an activity are indirect or induced changes that may occur as a result of the activity. These types of impacts include all the potential impacts that do not manifest immediately when the activity is undertaken or which occur at a different place as a result of the activity.*
- *Cumulative impacts are impacts that result from the incremental impact of the proposed activity on a common resource when added to the impacts of other past, present or reasonably foreseeable future activities. Cumulative impacts can occur from the collective*

impacts of individual minor actions over a period of time and can include both direct and indirect impacts.

The impact assessment methodology includes the aspects described below.

- **Step 1: Nature of impact/risk** - *The type of effect that a proposed activity will have on the environment.*
- **Step 2: Status** - *Whether the impact/risk on the overall environment will be:*
 - *Positive - environment overall will benefit from the impact/risk;*
 - *Negative - environment overall will be adversely affected by the impact/risk; or*
 - *Neutral - environment overall not be affected.*
- **Step 3: Qualitatively determine the consequence of the impact/risk by identifying the a) SPATIAL EXTENT; b) DURATION; c) REVERSIBILITY; AND d) IRREPLACEABILITY.**
 - **A) Spatial extent** – *The size of the area that will be affected by the impact/risk:*
 - *Site specific;*
 - *Local (<10 km from site);*
 - *Regional (<100 km of site);*
 - *National; or*
 - *International (e.g. Greenhouse Gas emissions or migrant birds).*
 - **B) Duration** – *The timeframe during which the impact/risk will be experienced:*
 - *Very short term (instantaneous);*
 - *Short term (less than 1 year);*
 - *Medium term (1 to 10 years);*
 - *Long term (the impact will cease after the operational life of the activity (i.e. the impact or risk will occur for the project duration)); or*
 - *Permanent (mitigation will not occur in such a way or in such a time span that the impact can be considered transient (i.e. the impact will occur beyond the project decommissioning)).*
 - **C) Reversibility of the Impacts** - *the extent to which the impacts/risks are reversible assuming that the project has reached the end of its life cycle (decommissioning phase):*
 - *High reversibility of impacts (impact is highly reversible at end of project life i.e. this is the most favourable assessment for the environment);*
 - *Moderate reversibility of impacts;*
 - *Low reversibility of impacts; or*
 - *Impacts are non-reversible (impact is permanent, i.e. this is the least favourable assessment for the environment).*
 - **D) Irreplaceability of Receiving Environment/Resource Loss** caused by impacts/risks – *the degree to which the impact causes irreplaceable loss of resources assuming that the project has reached the end of its life cycle (decommissioning phase):*

- *High irreplaceability of resources (project will destroy unique resources that cannot be replaced, i.e. this is the least favourable assessment for the environment);*
- *Moderate irreplaceability of resources;*
- *Low irreplaceability of resources; or*
- *Resources are replaceable (the affected resource is easy to replace/rehabilitate, i.e. this is the most favourable assessment for the environment).*

Some of the criteria are quantitative (e.g. spatial extent and duration) and some may be described in a quantitative or qualitative manner (e.g. reversibility and irreplaceability). The specialist then combines these criteria in a qualitative manner to determine the **consequence**.

The consequence terms ranging from slight to extreme must be calibrated per Specialist Study so that there is transparency and consistency in the way a risk/impact is measured. For example, from a biodiversity and ecology perspective, the consequence ratings could be defined according to a reduction in population or occupied area in relation to Species of Conservation Concern (SCC) status, ranging from slight consequence for defined areas of Least Concern, to extreme consequence for defined areas that are Critically Endangered. For example, from a social perspective, a slight consequence could refer to small and manageable impacts, or impacts on small sections of the community; a moderate consequence could refer to impacts which affect the bulk of the local population negatively or may produce a net negative impact on the community; and an extreme consequence could refer to impacts which could result in social or political violence or institutional collapse.

- **Consequence** – The anticipated consequence of the risk/impact is generally defined as follows:
 - *Extreme (extreme alteration of natural or socio-economic systems, patterns or processes, i.e. where environmental or socio-economic functions and processes are altered such that they permanently cease);*
 - *Severe (severe alteration of natural or socio-economic systems, patterns or processes, i.e. where environmental or socio-economic functions and processes are altered such that they temporarily or permanently cease);*
 - *Substantial (substantial alteration of natural or socio-economic systems, patterns or processes, i.e. where environmental or socio-economic functions and processes are altered such that they temporarily or permanently cease);*
 - *Moderate (notable alteration of natural or socio-economic systems, patterns or processes, i.e. where the natural or socio-economic environment continues to function but in a modified manner; or*
 - *Slight (negligible and transient alteration of natural or socio-economic systems, patterns or processes, i.e. where natural systems/environmental or socio-economic functions, patterns, or processes are not affected in a measurable manner, or if affected, that effect is transient and the system recovers).*
- **Step 4:** Rate the **probability** of the impact/risk using the criteria below:
 - **Probability** – The probability of the impact/risk occurring:
 - *Extremely unlikely (little to no chance of occurring);*
 - *Very unlikely (<30% chance of occurring);*

- *Unlikely (30-50% chance of occurring)*
 - *Likely (51 – 90% chance of occurring); or*
 - *Very Likely (>90% chance of occurring regardless of prevention measures).*
- **Step 5:** Use both the **consequence** and **probability** to determine the **significance** of the identified impact/risk (qualitatively as shown in Figure 16.5). Significance definitions and rankings are provided below:

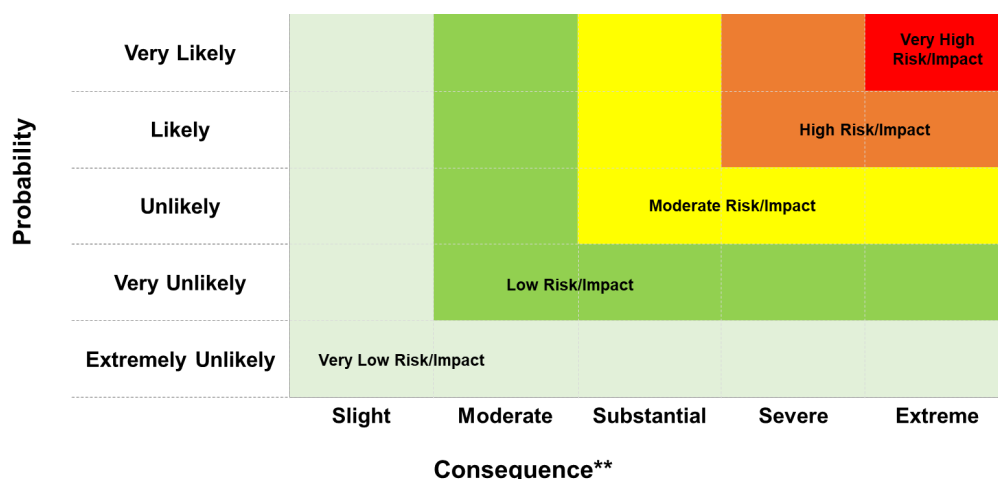

**[Qualitatively determined based on Spatial Extent, Duration, Reversibility and Irreplaceability]

Figure 16-5: Guide to assessing risk/impact significance as a result of consequence and probability.

- **Significance** – Will the impact cause a notable alteration of the environment?
 - *Very low (the risk/impact may result in very minor alterations of the environment and can be easily avoided by implementing appropriate mitigation measures, and will not have an influence on decision-making);*
 - *Low (the risk/impact may result in minor alterations of the environment and can be easily avoided by implementing appropriate mitigation measures, and will not have an influence on decision-making);*
 - *Moderate (the risk/impact will result in moderate alteration of the environment and can be reduced or avoided by implementing the appropriate mitigation measures, and will only have an influence on the decision-making if not mitigated);*
 - *High (the risk/impact will result in major alteration to the environment even with the implementation on the appropriate mitigation measures and will have an influence on decision-making); and*
 - *Very high (the risk/impact will result in very major alteration to the environment even with the implementation on the appropriate mitigation measures and will have an influence on decision-making (i.e. the project cannot be authorised unless major changes to the engineering design are carried out to reduce the significance rating)).*

With the implementation of mitigation measures, the residual impacts/risks are ranked as follows in terms of significance:

- *Very low = 5;*
- *Low = 4;*
- *Moderate = 3;*
- *High = 2; and*
- *Very high = 1.*

The specialists must provide a written supporting motivation of the assessment ratings provided.

- **Step 6:** *Determine the **Confidence Level** – The degree of confidence in predictions based on available information and specialist knowledge:*
 - *Low;*
 - *Medium; or*
 - *High.*

**APPENDIX E - COMPLIANCE WITH THE APPENDIX 6 OF THE 2014 EIA
 REGULATIONS (AS AMENDED)**

Requirements of Appendix 6 (Specialist Reports) of Government Notice R326 (Environmental Impact Assessment (EIA) Regulations of 2014, as amended)	Section where this has been addressed in the Specialist Report
1. (1) A specialist report prepared in terms of these Regulations must contain - a) details of - i. the specialist who prepared the report; and ii. the expertise of that specialist to compile a specialist report including a curriculum vitae;	Appendix A.
b) a declaration that the specialist is independent in a form as may be specified by the competent authority;	Appendix B
c) an indication of the scope of, and the purpose for which, the report was prepared;	Section 16.1.1
(cA) an indication of the quality and age of base data used for the specialist report;	Sections 16.2.1 and 16.2.2
(cB) a description of existing impacts on the site, cumulative impacts of the proposed development and levels of acceptable change;	Section 16.4 and Section 16.6.4
d) the duration, date and season of the site investigation and the relevance of the season to the outcome of the assessment;	Section 16.2.2
e) a description of the methodology adopted in preparing the report or carrying out the specialised process inclusive of equipment and modelling used;	Section 16.2
f) details of an assessment of the specific identified sensitivity of the site related to the proposed activity or activities and its associated structures and infrastructure, inclusive of a site plan identifying site alternatives;	Section 16.4.3 and Section 16.4.6
g) an identification of any areas to be avoided, including buffers;	Section 16.4.6
h) a map superimposing the activity including the associated structures and infrastructure on the environmental sensitivities of the site including areas to be avoided, including buffers;	Section 16.4.6
i) a description of any assumptions made and any uncertainties or gaps in knowledge;	Section 16.2.2
j) a description of the findings and potential implications of such findings on the impact of the proposed activity or activities;	Section 16,4 and 16,5
k) any mitigation measures for inclusion in the EMPr;	Section 16.9
l) any conditions for inclusion in the environmental authorisation;	Section 16.10.2
m) any monitoring requirements for inclusion in the EMPr or environmental authorisation;	Section 16.10.2
n) a reasoned opinion- i. whether the proposed activity, activities or portions thereof should be authorised; (iA) regarding the acceptability of the proposed activity or activities; and ii. if the opinion is that the proposed activity, activities or portions thereof should be authorised, any avoidance, management and mitigation measures that should be included in the EMPr, and where applicable, the closure plan;	Section 16.10.1
o) a description of any consultation process that was undertaken during the course of preparing the specialist report;	Section 16.2.3
p) a summary and copies of any comments received during any consultation process and where applicable all responses thereto; and	Section 16.5.2
q) any other information requested by the competent authority.	

Requirements of Appendix 6 (Specialist Reports) of Government Notice R326 (Environmental Impact Assessment (EIA) Regulations of 2014, as amended)	Section where this has been addressed in the Specialist Report
<p>(2) Where a government notice by the Minister provides for any protocol or minimum information requirement to be applied to a specialist report, the requirements as indicated in such notice will apply.</p>	<p>Note: Part A of the Assessment Protocols published in GN 320 on 20 March 2020 are not applicable as there are no dedicated Geohydrology or Groundwater themes on the National Web-based Environmental Screening Tool (Screening Tool) (as at May 2023). Section 16.4.5 and Appendix C</p>

APPENDIX F - OTHER RENEWABLE ENERGY PROJECTS WITHIN 30 KM OF THE KUDU SOLAR PV FACILITY

Table 16-19: Approved renewable energy projects, located within 30 km of the proposed Kudu Solar Facility.

CSIR No.	DFFE REFERENCE	TECHNOLOGY	MW/KV	STATUS	PROJECT TITLE	EIA REGULATIONS	ASSESSMENT PROCESS	APPLICANT	EAP
1	<ul style="list-style-type: none"> 12/12/20/2258 12/12/20/2258/1 	Solar PV	75	Approved and Preferred Bidder (Operational)	<ul style="list-style-type: none"> The Proposed Establishment of Photovoltaic (Solar Power) Farms in the Northern Cape Province - Kalkbult 	2010	Scoping and EIA	Scatec Solar SA Pty Ltd	Sustainable Development Projects cc
2	<ul style="list-style-type: none"> 12/12/20/2463/1 12/12/20/2463/1/2 12/12/20/2463/1/A2 12/12/20/2463/1/AM3 12/12/20/2463/1/AM4 12/12/20/2463/1/AM5 	Onshore Wind	140	Approved and Preferred Bidder (Operational)	<ul style="list-style-type: none"> Longyuan Mulilo De Aar 2 North Wind Energy Facility Longyuan Mulilo De Aar Maanhaarberg Wind Energy Facility The Wind Energy Facility (North and South) situated on the Plateau Near De Aar, Northern Cape Province 	2010 and 2014	Scoping and EIA and Amendment	Longyuan Mulilo De Aar 2 South (Pty)	Aurecon South Africa (Pty) Ltd and Holland and Associates Environmental Consultants
3	<ul style="list-style-type: none"> 12/12/20/2463/2 12/12/20/2463/2/AM2 	Onshore Wind	100	Approved and Preferred Bidder (Operational)	<ul style="list-style-type: none"> Longyuan Mulilo De Aar Maanhaarberg Wind Energy Facility The Wind Energy Facility (North and South) Situated On The Plateau Near De Aar, Northern Cape Province 	2010 and 2014	Scoping and EIA and Amendment	Mulilo Renewable Energy (Pty) Ltd	Aurecon South Africa (Pty) Ltd
4	<ul style="list-style-type: none"> 14/12/16/3/3/1/1166 14/12/16/3/3/1/1166/AM3 14/12/16/3/3/1/1166/AM4 	Transmission line	132	Approved	<ul style="list-style-type: none"> Basic Assessment for the proposed construction of a 132 kV transmission line 	2010 and 2014	Basic Assessment	Longyuan Mulilo De Aar 2 North (Pty) Ltd	Aurecon South Africa (Pty) Ltd

ENVIRONMENTAL IMPACT ASSESSMENT REPORT: Scoping and Environmental Impact Assessment (EIA) Process for the Proposed Development of a Solar Photovoltaic (PV) Facility (Kudu Solar Facility 7) and associated infrastructure, near De Aar, Northern Cape Province

CSIR No.	DFFE REFERENCE	TECHNOLOGY	MW/KV	STATUS	PROJECT TITLE	EIA REGULATIONS	ASSESSMENT PROCESS	APPLICANT	EAP
					corridor adjacent to the existing Eskom transmission line from Longyuan Mulilo De Aar 2 North Wind Energy Facility (WEF) to the Hydra Substation in De Aar, Northern Cape				
5	<ul style="list-style-type: none"> 14/12/16/3/3/1/785 	Transmission line	132	Approved	<ul style="list-style-type: none"> Proposed construction of two 132kV transmission lines from the South & North Wind Energy Facilities on the Eastern Plateau (De Aar 2) near De Aar, Northern Cape. 	2010	Basic Assessment	Mulilo Renewable Energy (Pty) Ltd	Aurecon South Africa (Pty) Ltd
6	<ul style="list-style-type: none"> 14/12/16/3/3/2/278 14/12/16/3/3/2/278/1 14/12/16/3/3/2/278/2 	Onshore Wind	118	Approved	<ul style="list-style-type: none"> Proposed Castle Wind Energy Facility Project, located near De Aar, Northern Cape 	2010 and 2014	Scoping and EIA	Castle Wind Farm (Pty) Ltd	Aurecon South Africa (Pty) Ltd; and Savannah Environmental Consultants (Pty) Ltd
7	<ul style="list-style-type: none"> 14/12/16/3/3/2/564 14/12/16/3/3/2/564/AM1 14/12/16/3/3/2/564/AM2 	Solar PV	75	To be confirmed	<ul style="list-style-type: none"> Proposed Swartwater 75MW solar PV power facility in Petrusville within Renosterburg Local Municipality, Northern Cape 	2010 and 2014	Scoping and EIA and Amendment	AE-AMD Renewable Energy (Pty) Ltd	USK Environmental and Waste Engineering (Pty) Ltd
8	<ul style="list-style-type: none"> 14/12/16/3/3/2/740 	Solar PV	300	Approved	<ul style="list-style-type: none"> Proposed 300MW Solar Power Plant in Phillipstown area in Renosterberg Local Municipality 	2010	Scoping and EIA	To be confirmed	Tshikovha Environmental and Communication Consultants

ENVIRONMENTAL IMPACT ASSESSMENT REPORT: Scoping and Environmental Impact Assessment (EIA) Process for the Proposed Development of a Solar Photovoltaic (PV) Facility (Kudu Solar Facility 7) and associated infrastructure, near De Aar, Northern Cape Province

CSIR No.	DFFE REFERENCE	TECHNOLOGY	MW/ KV	STATUS	PROJECT TITLE	EIA REGULATIONS	ASSESSMENT PROCESS	APPLICANT	EAP
9	<ul style="list-style-type: none"> 14/12/16/3/3/2/744 	Solar PV	0	Approved	<ul style="list-style-type: none"> Proposed PV facility on farm Jakhalsfontein near De Aar 	2010	Scoping and EIA	Solar Capital (Pty) Ltd	Eco Compliance (Pty) Ltd
10	<ul style="list-style-type: none"> 14/12/16/3/3/2/739 	Solar PV	70 - 100	To be confirmed	<ul style="list-style-type: none"> Proposed 70 - 100 MW Solar Power Plant in Petrusville 	2010	Scoping and EIA	To be confirmed	Tshikovha Environmental and Communication Consultants
11	<ul style="list-style-type: none"> Not issued yet (it is understood that the project is still within the pre-application stage) 	Solar PV	800 (Maximum)	Pre-Application	<ul style="list-style-type: none"> The Proposed Keren Energy Odyssey Solar PV Facilities (Odyssey Solar 1, Odyssey Solar 2, Odyssey Solar 3, Odyssey Solar 4, Odyssey Solar 5, Odyssey Solar 6, Odyssey Solar 7 And Odyssey Solar 8) 	2014	Scoping and EIA	Keren Energy Group Holdings	EnviroAfrica cc
12	<ul style="list-style-type: none"> To be confirmed 	Solar PV	3050	Scoping	<ul style="list-style-type: none"> The Proposed Development of the Crossroads (formally referred to as the Hydra B) Green Energy Cluster of Renewable Energy Facilities and Grid Connection Infrastructure, Pixley Ka Seme District Municipality, Northern Cape Province. The Cluster entails the development of up to 21 solar energy facilities, with the Scoping and EIA Processes consisting of three phases. Phases 1, 2 and 3 consist of 	2014	Scoping and EIA	Akuo Energy Afrique	Savannah Environmental Consultants (Pty) Ltd

ENVIRONMENTAL IMPACT ASSESSMENT REPORT: Scoping and Environmental Impact Assessment (EIA) Process for the Proposed Development of a Solar Photovoltaic (PV) Facility (Kudu Solar Facility 7) and associated infrastructure, near De Aar, Northern Cape Province

CSIR No.	DFFE REFERENCE	TECHNOLOGY	MW/KV	STATUS	PROJECT TITLE	EIA REGULATIONS	ASSESSMENT PROCESS	APPLICANT	EAP
					9, 6 and 6 solar facilities, respectively. The Phase 1 Scoping and EIA Processes were launched in January 2023.				
Study area shown on map	<ul style="list-style-type: none"> • 14/12/16/3/3/2/2244 • 14/12/16/3/3/2/2245 • 14/12/16/3/3/2/2246 • 14/12/16/3/3/2/2247 • 14/12/16/3/3/2/2248 • 14/12/16/3/3/2/2249 • 14/12/16/3/3/2/2250 • 14/12/16/3/3/2/2251 • 14/12/16/3/3/2/2252 • 14/12/16/3/3/2/2253 • 14/12/16/3/3/2/2254 • 14/12/16/3/3/2/2255 	Solar PV	2180	Scoping and EIA Process underway	<ul style="list-style-type: none"> • Proposed Development of 12 Solar Photovoltaic (PV) Facilities (Kudu Solar Facility 1 to 12) and associated infrastructure, near De Aar, Northern Cape Province 	2014	Scoping and EIA	Kudu Solar Facility 1 (Pty) Ltd to Kudu Solar Facility 12 (Pty) Ltd	CSIR
Shown on map as Existing HV Lines	<ul style="list-style-type: none"> • N/A 	Transmission Line	220	Existing Power Line	<ul style="list-style-type: none"> • HYDRA ROODEKUIL 2 	-	-	-	-
Shown on map as Existing HV Lines	<ul style="list-style-type: none"> • N/A 	Transmission Line	132	Existing Power Line	<ul style="list-style-type: none"> • HYDRA ROODEKUIL 1 	-	-	-	-
Shown on map as	<ul style="list-style-type: none"> • N/A 	Transmission Line	765	Existing Power Line	<ul style="list-style-type: none"> • BETA HYDRA 2 	-	-	-	-

CSIR No.	DFFE REFERENCE	TECHNOLOGY	MW/KV	STATUS	PROJECT TITLE	EIA REGULATIONS	ASSESSMENT PROCESS	APPLICANT	EAP
Existing HV Lines									
Shown on map as Existing HV Lines	<ul style="list-style-type: none"> N/A 	Transmission Line	400	Existing Power Line	<ul style="list-style-type: none"> HYDRA PERSEUS 3 	-	-	-	-
Shown on map as Existing HV Lines	<ul style="list-style-type: none"> N/A 	Transmission Line	220	Existing Power Line	<ul style="list-style-type: none"> VAN DER KLOOF ROODEKUIL 2 	-	-	-	-
Shown on map as Existing HV Lines	<ul style="list-style-type: none"> N/A 	Transmission Line	220	Existing Power Line	<ul style="list-style-type: none"> VAN DER KLOOF ROODEKUIL 1 	-	-	-	-
Shown on map as Existing HV Lines	<ul style="list-style-type: none"> N/A 	Transmission Line	400	Existing Power Line	<ul style="list-style-type: none"> BETA HYDRA 1 	-	-	-	-
Shown on map as Existing HV Lines	<ul style="list-style-type: none"> N/A 	Transmission Line	400	Existing Power Line	<ul style="list-style-type: none"> HYDRA PERSEUS 2 	-	-	-	-
Shown on map as	<ul style="list-style-type: none"> N/A 	Transmission Line	132	Existing Power Line	<ul style="list-style-type: none"> KALKBULT/KAREEBOSCH PAN 1 	-	-	-	-

CSIR No.	DFFE REFERENCE	TECHNOLOGY	MW/KV	STATUS	PROJECT TITLE	EIA REGULATIONS	ASSESSMENT PROCESS	APPLICANT	EAP
Existing HV Lines									
Shown on map as Existing HV Lines	<ul style="list-style-type: none"> N/A 	Transmission Line	132	Existing Power Line	<ul style="list-style-type: none"> ROODEKUIL/ORANIA 1 	-	-	-	-
Shown on map as Planned HV Lines	<ul style="list-style-type: none"> N/A 	Transmission Line	765	Planned Power Line	<ul style="list-style-type: none"> Perseus to Gamma 2nd 765 kV line Cape Corridor Phase 4: 2nd Zeus-Per-Gam-Ome 765kV Line 	-	-	-	-
Shown on map as Planned HV Lines	<ul style="list-style-type: none"> N/A 	Transmission Line	765	Planned Power Line	<ul style="list-style-type: none"> Relocate Beta-Hydra 765kV line to form Perseus-Hydra 1st 765kV line Cape Corridor Phase 2: Zeus - Hydra 765kV Integration 	-	-	-	-
Shown on map as Planned HV Lines	<ul style="list-style-type: none"> N/A 	Transmission Line	765	Planned Power Line	<ul style="list-style-type: none"> Perseus to Gamma 2nd 765 kV line Cape Corridor Phase 4: 2nd Zeus-Per-Gam-Ome 765kV Line 	-	-	-	-



CHAPTER 17: Geotechnical Assessment



GEOTECHNICAL ASSESSMENT:

Scoping and Environmental Impact Assessment (EIA) Process for the Proposed Development of a Solar Photovoltaic Facility (Kudu Solar Facility 7) and associated infrastructure, near De Aar, Northern Cape Province

<i>Report prepared for:</i>	<i>Report prepared by:</i>
CSIR – Environmental Management Services P O Box 320 Stellenbosch 7599 South Africa	Hardy Luttig, Shane Teek & Dale Barrow GEOSS South Africa (Pty) Ltd P.O. Box 12412 Die Boord, Stellenbosch 7613 Stellenbosch, South Africa 7600

Version 0: 13 April 2023

EXECUTIVE SUMMARY

This report summarises the results from a desktop specialist study which aimed to project a high-level overview of envisaged risks from a geotechnical standpoint, and provide broad recommendations for high-level designs. The following conclusions can be drawn from the investigation:

1. Based on the findings of this geotechnical desktop study, development should proceed provided the mitigation measures are implemented.
2. Increased soil erosion and contamination may transpire as an impact of the proposed development, and this may persist for the life of the project. However, the impact of this is expected to be very low to low significance during all phases of the development (i.e., construction, operation and decommissioning).
3. Published data for the area, e.g., geological map, is generally confirmed by fieldwork undertaken by GEOSS in the area. However, variable soil and rock conditions will exist across the site, broadly these have been divided as follows:
 - a. Zone A – Karoo Sandstones and mudstones
 - b. Zone B – Karoo dolerite
 - c. Zone C – Areas of thicker soil cover (generally within drainage channels)
4. It is anticipated that conventional foundations can be employed for all structures. Karoo mudrock and sandstone should be avoided when selecting aggregates for concrete mixes.
5. The footprint of each proposed structure would have to be investigated prior to compilation of final design.
6. Owing to the variable geologic and soil conditions across the proposed development area, the subgrade conditions will vary across the site. Dolerite has been proven to perform well as an aggregate for wearing courses in other areas of the Karoo. Dolerite has also been incorporated as an aggregate in concrete mixes.
7. The excavatability of the stratum on site are anticipated to be variable, based on material composition and texture, the degree of weathering, and the nature of discontinuities within the rock and/or soil mass.
8. The seismicity in the region should be considered during design.
9. Road cuttings and drainage systems should be designed by an appropriately qualified professional.
10. Detailed geotechnical investigations will need to be undertaken prior to construction. Such investigations would not be required to fulfil the requirements of the EIA process. However, it would be necessary prior to construction.

11. GEOSS has endeavoured to highlight and characterise all potential geotechnical risks that are presented by the site that has been proposed for development. However, due to the anisotropic (variable) nature of earth materials, each point on the site will present results that differ. For this reason, it is considered of the utmost importance that the foundation excavations be inspected prior to casting to ensure that soil with an adequate bearing capacity is obtained beneath each footing, and/or piling conditions be assessed. These works should be carried out by an appropriately qualified individual, during construction of the facility.



CONTENTS

17. GEOTECHNICAL ASSESSMENT	17-11
17.1 Introduction	17-11
17.1.1 Scope, Purpose and Objectives of this Specialist Report	17-11
17.1.2 Details of Specialist	17-11
17.1.3 Terms of Reference	17-11
17.1.4 Proposed Development	17-12
17.2 Approach and Methodology	17-14
17.2.1 Information Sources	17-14
17.2.2 Assumptions, Knowledge Gaps and Limitations	17-15
17.2.3 Consultation Processes Undertaken	17-16
17.3 Description of Project Aspects relevant to this Geotechnical Specialist Assessment	17-16
17.4 Baseline Environmental Description	17-16
17.4.1 Study Area Definition	17-16
17.4.2 General Description	17-17
17.4.3 Project Specific Description	17-19
17.4.3.1 Climate	17-19
17.4.3.2 Weinert 'N' Value	17-20
17.4.3.3 Regional Geology	17-20
17.4.3.4 Geotechnical Properties and Engineering Geology	17-21
17.4.4 Identification of Environmental Sensitivities	17-27
17.4.4.1 Sensitivities identified by the National Web-Based Environmental Screening Tool	17-27
17.4.4.2 Specialist Sensitivity Analysis and Verification	17-27
17.4.4.3 Sensitivity Analysis Summary Statement	17-27
17.5 Issues, Risks and Impacts	17-29
17.5.1 Identification of Potential Impacts/Risks	17-29
17.5.2 Summary of Issues identified during the Public Consultation Phase	17-29
17.6 Impact Assessment	17-30
17.6.1 Potential Impacts during the Construction Phase	17-30
17.6.1.1 Impact 1: Displacement of Geologic Material: Removal of rocks and other geologic materials for site levelling and grading, resulting in loss of	

	geologic materials, e.g., topsoil removal/loss, and potentially the destruction of habitats of endemic species. _____	17-30
17.6.1.2	Impact 2: Contamination of geologic materials as a consequence of the construction activities by earthworks machinery and other apparatus. 17-	31
17.6.1.3	Impact Summary Tables: Construction Phase _____	17-31
17.6.2	Potential Impacts during the Operational Phase _____	17-35
17.6.2.1	Impact 1: Increased unnatural hard surfaces yielding increased runoff, potentially increasing erosion. _____	17-35
17.6.2.2	Impact 2: Contamination of geologic materials as a consequence of typical maintenance activities, as example, washing of solar panels, or spillages associated with battery energy storage facilities. _____	17-35
17.6.2.3	Impact Summary Tables: Operational Phase _____	17-35
17.6.3	Potential Impacts during the Decommissioning Phase _____	17-38
17.6.3.1	Impact 1: Increased unnatural hard surfaces yielding increased runoff, potentially increasing erosion. _____	17-38
17.6.3.2	Impact 2: Contamination and disturbance of geologic materials as a consequence of typical decommissioning activities. _____	17-38
17.6.3.3	Impact Summary Tables: Decommissioning Phase _____	17-38
17.6.4	Cumulative Impacts _____	17-40
17.6.5	Potential Cumulative Impacts during the Construction Phase _____	17-41
17.6.5.1	Impact 1: Displacement of Geologic Material: Removal of rocks and other geologic materials for site levelling and grading, resulting in loss of geologic materials, e.g., topsoil removal/loss, and potentially the destruction of habitats of endemic species. _____	17-41
17.6.5.2	Impact 2: Contamination of geologic materials as a consequence of the construction activities by earthworks machinery and other apparatus. _____	17-41
17.6.6	Potential Impacts during the Operational Phase _____	17-41
17.6.6.1	Impact 1: Increased unnatural hard surfaces yielding increased runoff, potentially increasing erosion. _____	17-41
17.6.6.2	Impact 2: Contamination of geologic materials as a consequence of typical maintenance activities, as example, washing of solar panels, or spillages associated with battery energy storage facilities. _____	17-41
17.6.7	Potential Impacts during the Decommissioning Phase _____	17-42
17.6.7.1	Impact 1: Increased unnatural hard surfaces yielding increased runoff, potentially increasing erosion. _____	17-42
17.6.7.2	Impact 2: Contamination and disturbance of geologic materials as a consequence of typical decommissioning activities. _____	17-42
17.6.7.3	Impact Summary Tables: Cumulative Impacts _____	17-42
17.6.8	No-go Alternatives _____	17-50
17.6.9	Battery Energy Storage System _____	17-50
17.7	Impact Assessment Summary _____	17-50
17.8	Legislative and Permit Requirements _____	17-51
17.8.1	Loss of geologic materials (soil erosion) _____	17-51
17.8.2	Contamination of geologic materials _____	17-51
17.9	Environmental Management Programme Inputs _____	17-52

17.10 Final Specialist Statement and Authorisation Recommendation	17-53
17.10.1 Statement and Reasoned Opinion	17-53
17.10.2 EA Condition Recommendations	17-55
17.11 References	17-56
APPENDICES	17-57
APPENDIX A - SPECIALIST EXPERTISE	17-57
APPENDIX B - SPECIALIST STATEMENT OF INDEPENDENCE	17-61
APPENDIX C - SITE SENSITIVITY VERIFICATION	17-70
APPENDIX D - IMPACT ASSESSMENT METHODOLOGY	17-71
APPENDIX E - COMPLIANCE WITH THE APPENDIX 6 OF THE 2014 EIA REGULATIONS (AS AMENDED)	17-76
APPENDIX F - APPROVED RENEWABLE ENERGY PROJECTS	17-78
APPENDIX G - RELEVANT GEOTECHNICAL LITERATURE & INFORMATION	17-83



TABLES

Table 17-1: Information sources used to assess the Geotechnical conditions for the proposed Kudu Solar Facility. _____	17-14
Table 17-2: Geological formation within the study area. _____	17-20
Table 17-3: Impact Summary Tables: Construction Phase _____	17-32
Table 17-4: Impact Summary Tables: Operational Phase _____	17-36
Table 17-5: Impact Summary Tables: Decommissioning Phase _____	17-39
Table 17-6: Cumulative Impact Summary Tables: Construction Phase _____	17-43
Table 17-7: Cumulative Impact Summary Tables: Operational Phase _____	17-46
Table 17-8: Cumulative Impact Summary Tables: Decommissioning Phase _____	17-48
Table 17-9: Overall Impact Significance (Post Mitigation) _____	17-50
Table 17-10: Approved renewable energy projects, located within 30 km of the proposed Kudu Solar Facility. _____	17-78
Table 17-11: Strength and deformation characteristics of some Karoo Sandstones (Brink, 1983). _____	17-83
Table 17-12: Geotechnical properties of Ecca Group sandstone at Matimba Power Station (Brink, 1983). _____	17-84
Table 17-13: Drying and shrinkage determinations on some sandstones of the Beaufort Group (Brink, 1983). _____	17-84
Table 17-14: Road construction characteristics of some Karoo sandstones (Brink, 1983). _____	17-85
Table 17-15: Changes in engineering properties of Adelaide Subgroup sandstone aggregates under traffic (Brink, 1983). _____	17-86
Table 17-16: Engineering properties of very hard rock dolerite from various locations (Brink, 1983). _____	17-87
Table 17-17: Strength properties of fresh dolerite from various locations (Brink, 1983). _____	17-88
Table 17-18: Weathering classes and characteristics of dolerite in South Africa (Brink, 1983). _____	17-90
Table 17-19: Influence of climate on selected physical properties of weathering classes of dolerites (Brink, 1983). _____	17-91
Table 17-20: Concrete making properties of dolerite (Brink, 1983). _____	17-92
Table 17-21: Deformation characteristics (expressed in MPa) for different weathering classes of dolerite from South Africa as determined by a GB Menard pressure meter and jacking tests (Brink, 1983). _____	17-92

FIGURES

Figure 17-1:	Monthly average air temperature distribution for the Kudu Solar Facility study area (Schulze, 2009)	17-19
Figure 17-2:	Monthly average rainfall and potential evaporation distribution for the Kudu Solar Facility study area (Schulze, 2009).	17-19
Figure 17-3:	Climatic 'N' value = 5 plotted for southern Africa (after Weinert, 1967).	17-20
Figure 17-4:	Elements of typical Karoo hillslopes and anticipated soil profiles (Brink, 1982)	17-22
Figure 17-5:	Zones in South Africa with nominal peak ground acceleration (NPGA) of more than 0.1 g for 10% in 50 years probability showing approximate position of the Kudu Solar Facility (after Retief and Dunaiski, 2009).	17-23
Figure 17-6:	Guide to assessing risk/impact significance as a result of consequence and probability.	17-74
Figure 17-7:	Relation between shrinkage and surface area for a variety of rocks including Karoo sandstone (Brink, 1983).	17-85
Figure 17-8:	Variations of the shear strength to unconfined compressive strength ratio with the Unconfined Compressive Strength (UCS) for dolerite compared with other rock types (Brink, 1983).	17-89
Figure 17-9:	Relation between tensile strength and Unconfined Compressive Strength (UCS) of fresh dolerite specimen from South Africa (Brink, 1983).	17-89

MAPS

Map 17-1:	Locality map showing the location of the proposed Kudu Solar Facility and surrounds.	17-13
Map 17-2:	Aerial view delineating the study area of the 12 Kudu Solar Facilities (Google, 2022). Note that this report is focused on Kudu Solar Facility 7.	17-18
Map 17-3:	Geological setting of the study area for the 12 Kudu Solar Facilities. Note that this report is focused on Kudu Solar Facility 7.	17-24
Map 17-4:	Broad geotechnical zones across the study area. Note that this report is focused on Kudu Solar Facility 7.	17-25
Map 17-5:	Regional slope classification based on Stiff et al. (1996). Note that this report is focused on Kudu Solar Facility 7.	17-26
Map 17-6:	Detailed layout of Kudu Solar Facility 7.	17-28
Map 17-7:	Approved renewable energy projects within a 30 km radius from the proposed Kudu Solar Facility.	17-49

ABBREVIATIONS

Abbreviations	
AASHTO	American Association of State Highway and Transportation Officials
BH	Borehole
CBR	California bearing ratio
CGS	Council for Geoscience
CSIR	Council for Scientific and Industrial Research
DWS	Department of Water Affairs and Sanitation
EAM	Engineering and Asset Management
EC	electrical conductivity
EOH	End of Hole
g	Gravity
L/s	litres per second
LL	Liquid Limit
LS	Linear Shrinkage
LSSG	Lower selected sub-grade
m	metres
MCCSSO	Moisture content, colour, consistency, structure, soil type, and origin.
MDD	Maximum Dry Density
mm	millimetre
MOD	Modified AASHTO
mS/m	milli-Siemens per metre
NGA	National Groundwater Archive
NHBRC	National Home Builders Registration Council
OMC	Optimum moisture content
PI	Plasticity Index
TLB	Tractor loader backhoe
UFST	Underground Fuel Storage Tanks
USSG	Upper selected sub-grade



GLOSSARY

Definitions	
Aquifer	a geological formation, which has structures or textures that hold water or permit appreciable water movement through them [from National Water Act (Act No. 36 of 1998)]
Electrical conductivity	the ability of groundwater to conduct electrical current due to the presence of charged ionic species in solution (Freeze and Cherry, 1979)
Fractured aquifer	Describes an aquifer where groundwater only occurs in narrow fractures within the bedrock
Geologic materials	Primarily rock and soil (synonymous with Geological)
Geotechnical zone	Region where similar geotechnical conditions are anticipated.
Groundwater	Water found in the subsurface in the saturated zone below the water table or piezometric surface, i.e., the water table marks the upper surface of groundwater systems.
Intergranular aquifer (or primary aquifer)	An aquifer in which groundwater is stored within and flows through open pore spaces in the unconsolidated granular Quaternary deposits
Lithology/lithologies	A specific rock type, e.g., sandstone, shale or granite etc.
Pedocrete	Superficial deposits, not of sedimentary origin, which have formed through either weathering residues, or cementation or replacement of existing soils (by precipitates derived from soil-water and or groundwater), or a combination of such processes. Several chemical agents replace or cement, e.g., calcium carbonates (calcrete) and/or iron oxides (ferricrete)

17. GEOTECHNICAL ASSESSMENT

This chapter includes the Geotechnical Specialist Assessment that was prepared by GEOSS South Africa, as part of the Scoping and Environmental Impact Assessment (EIA) Process for the proposed development of the Kudu Solar Facility 7 and associated infrastructure, near De-Aar, Northern Cape Province (Map 17-1). Kudu Solar Facility 7 forms part of a cluster of 12 Solar Photovoltaic (PV) projects proposed by the Project Developer.

17.1 Introduction

17.1.1 Scope, Purpose and Objectives of this Specialist Report

The primary objective of the desktop assessment is to summarise the area's geology, including the likely distribution of potential geotechnical challenges related to the underlying geology. Provide geotechnical impact assessment of the proposed development on the receiving environment, e.g., providing mitigation measures to limit impacts of concentrated runoff generated by hard surfaces resulting in increased soil erosion.

This chapter only addresses Kudu Solar Facility 7 (hereafter referred to as the "Kudu Solar Facility" or "proposed project").

17.1.2 Details of Specialist

This specialist assessment has been undertaken by Hardy Luttig, Shane Teek, and Dale Barrow of GEOSS South Africa. Hardy Luttig obtained a Bachelor degree in Earth Science and a Masters in Geotechnical Engineering at the University of Stellenbosch. Shane Teek is registered as a candidate with the SACNASP, with Registration Number 126397. Dale Barrow is registered as a professional with the SACNASP, with Registration Number 400829/13. A curriculum vitae is included for all parties in Appendix A of this Specialist Assessment.

In addition, a signed specialist statement of independence is included in Appendix B of this Specialist Assessment.

17.1.3 Terms of Reference

The Terms of Reference for the geotechnical desktop specialist study are as follows:

- Compile and review available geological and geotechnical information for the region, including the anticipated soil conditions.
- Determine whether problem soils are likely to be encountered within the study area.
- A general discussion of possible and likely engineering characteristics of the respective geological materials.
- Identify possible development constraints that may be present across the study area, e.g., topographical constraints, major discontinuities, or shallow groundwater conditions (permanent or non-permanent).

- An evaluation of the seismic potential of the area based on available published literature.
- Provide commentary on any potentially sensitive areas across the site, such as ridges, outcrops and exposures.
- Provide broad recommendations that may be used to guide the geotechnical design and plan future investigations within the study area.
- Specification of set-backs or buffers (if any), and provide clear reasons for these recommendations.
- Provide review input on the preferred infrastructure layout following the sensitivity analysis and layout identification.
- Summarise, classify and categorise geotechnical risks that may arise due to the development and provide relevant mitigation measures to manage said risks.
- Provide spatial mapping of geotechnical zones where similar environmental conditions are expected.
- Provide spatial mapping of slope classification, where development is most to least favourable, based on Stiff et al. (1996).
- Identify and assess the potential direct, indirect and cumulative impacts of the proposed development on the receiving environment from a geotechnical perspective.
- A description of assumptions and limitations used.
- Identification of additional protocols, licensing and/or permitting requirements that are relevant to the project and the implications thereof, if any.
- Provide recommendations with regards to potential monitoring programmes.
- Determine mitigation and/or management measures, which could be implemented to as far as possible, reduce the effect of negative impacts and enhance the effect of positive impacts. Also, identify best practice management actions, monitoring requirements, and rehabilitation guidelines for all identified impacts, for inclusion in the Environmental Management Programme (EMPr).
- Review the Generic EMPr for Substations (GN 435) and confirm if there are any specific environmental sensitivities or attributes present on the site and any resultant site-specific impact management outcomes and actions that need to be included.
- Provide a reasoned opinion indicating the acceptability of the proposed development and a recommendation if the development should go ahead or not.

17.1.4 Proposed Development

The proposed development includes all components of the Kudu Solar Facility, e.g., the erection of PV tables for the generation of solar power, associated electrical infrastructure (above and/or below the surface), ancillary structures for site security and/or transformers, battery energy storage system(s) (BESS), as well as access tracks/roads and boundary fences.