

KITCHEN & TOILET - PLAN  
Scale 1:20

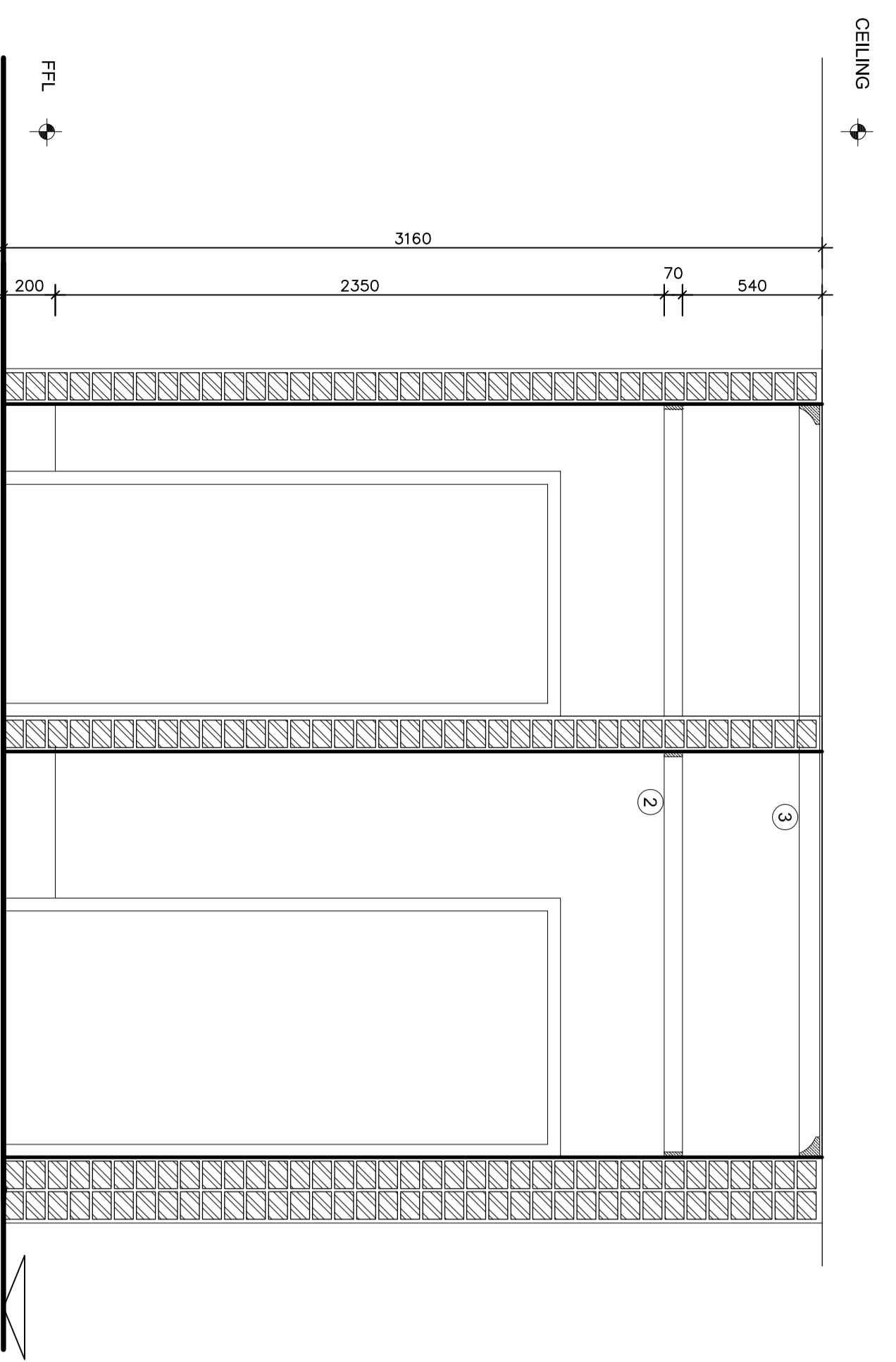

KITCHEN & TOILET - ELEVATION 1  
Scale 1:20

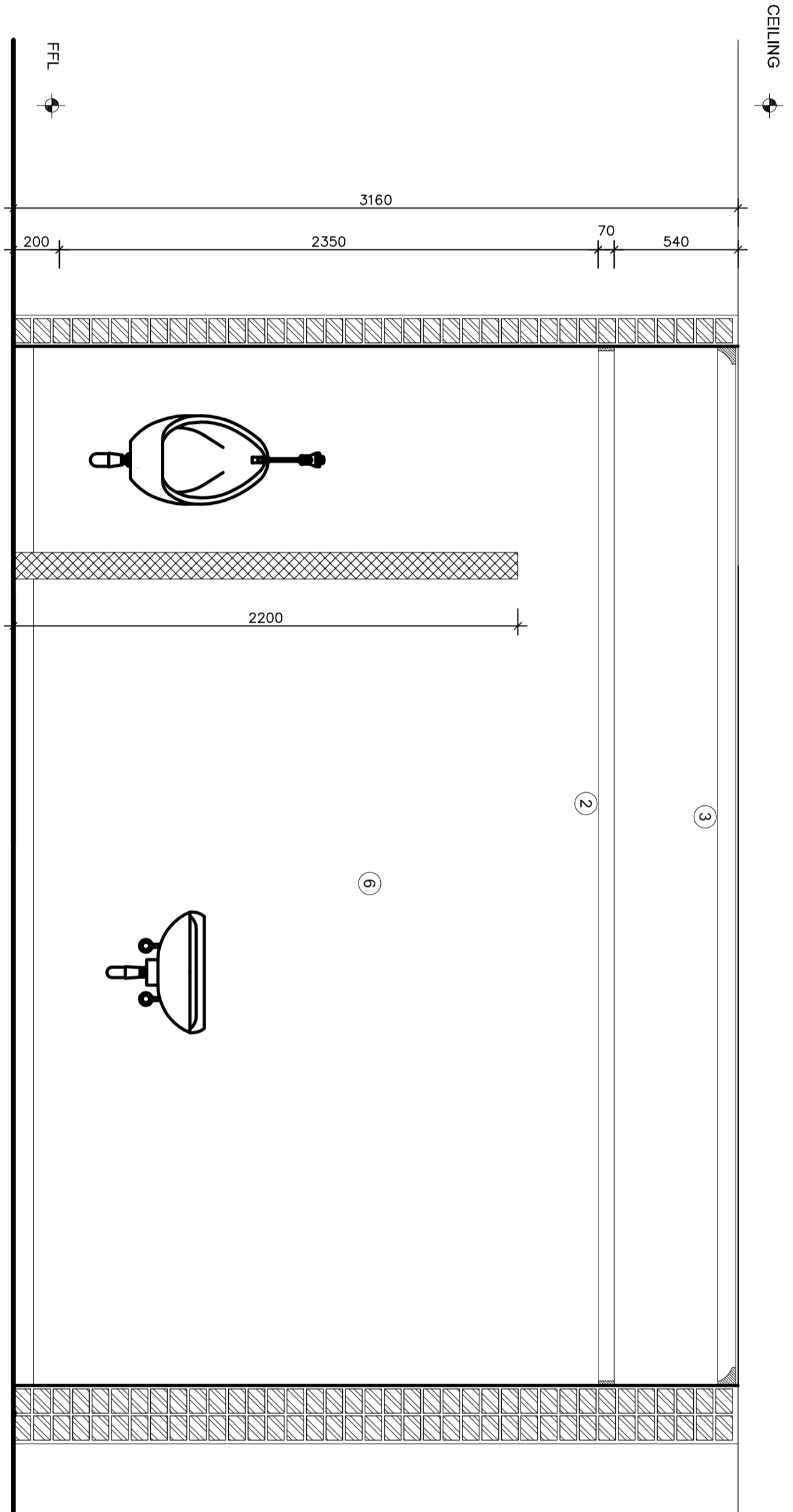

KITCHEN & TOILET - ELEVATION 2  
Scale 1:20

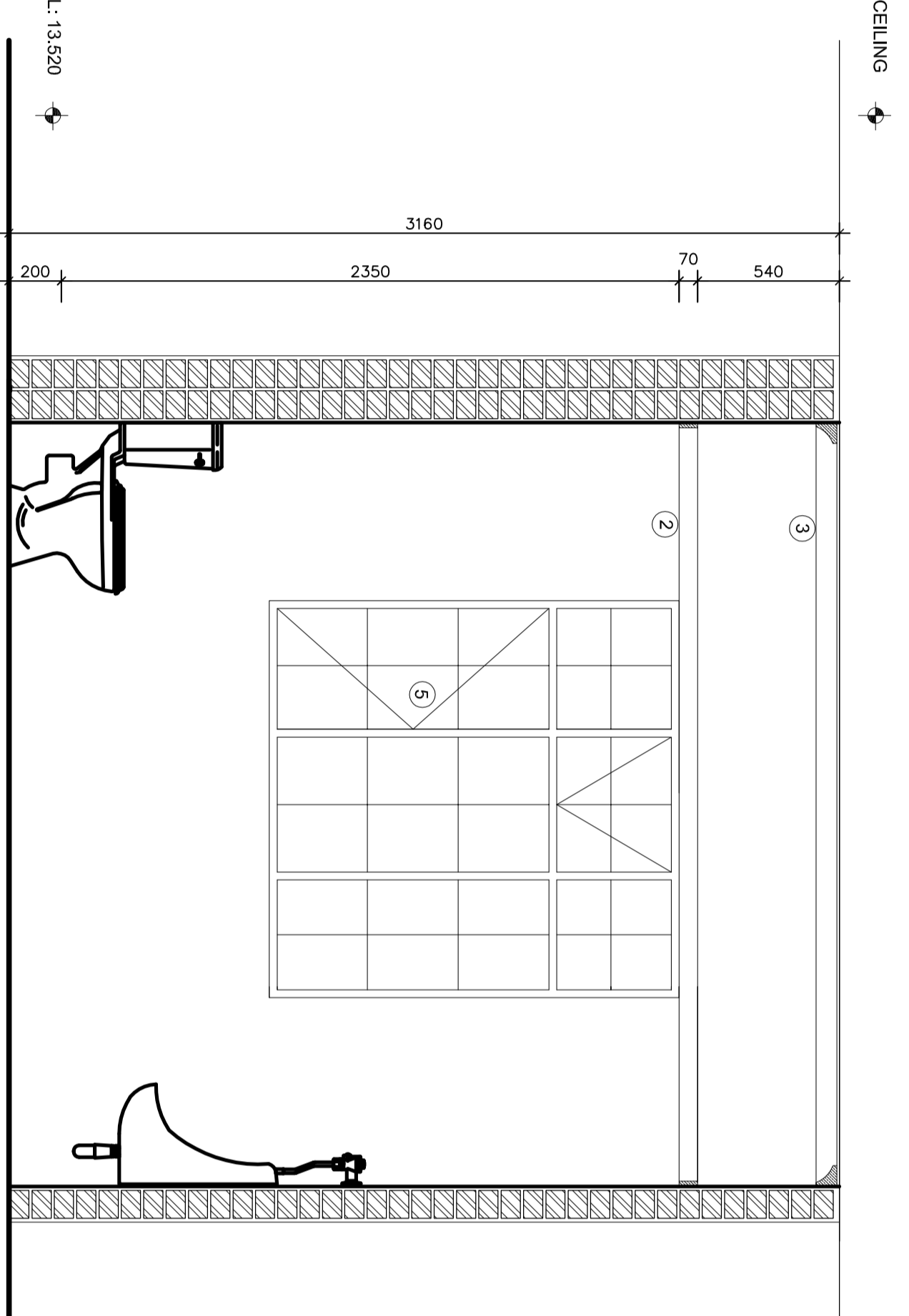

KITCHEN & TOILET - ELEVATION 3  
Scale 1:20

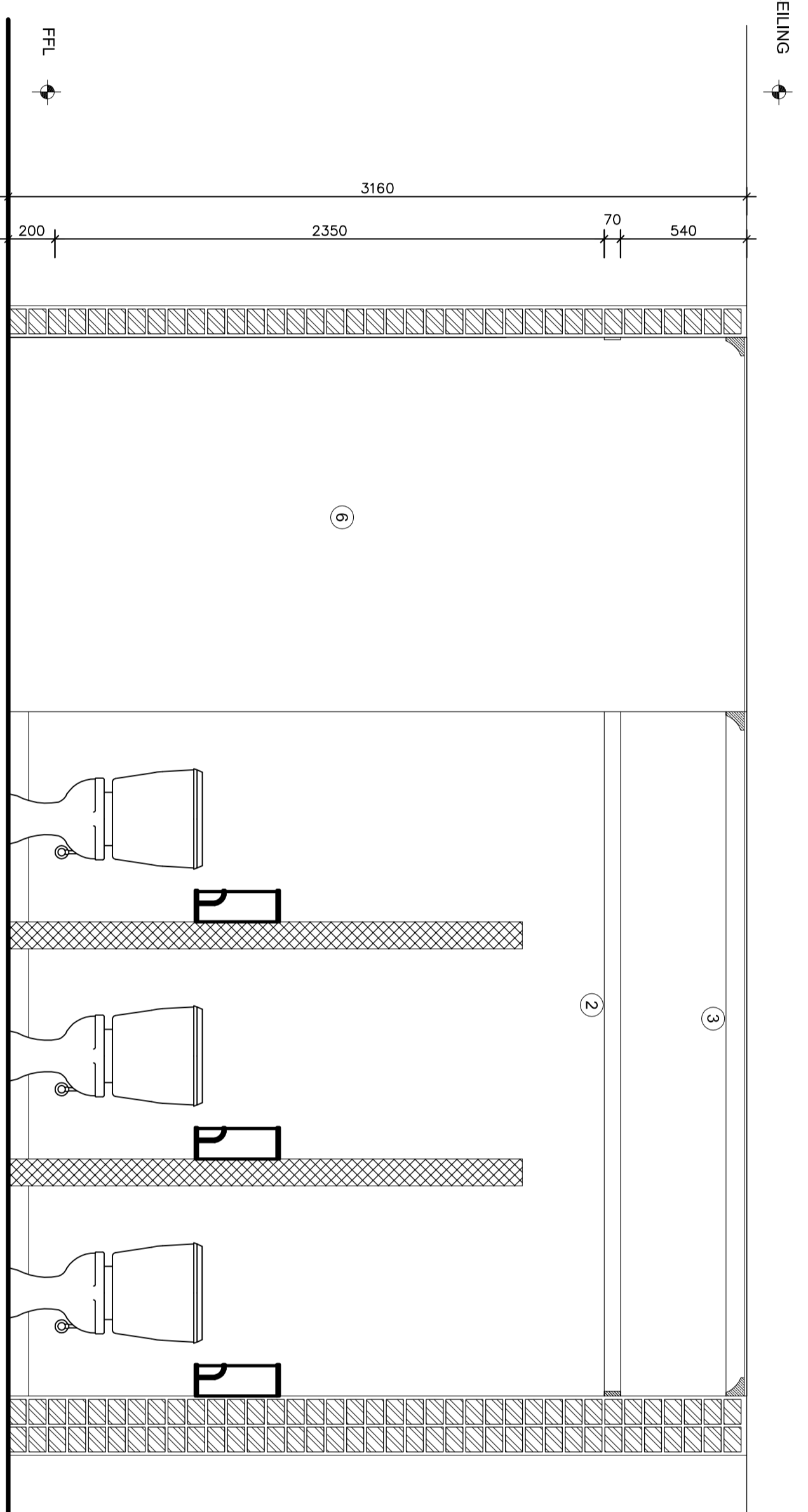

KITCHEN & TOILET - ELEVATION 4  
Scale 1:20

- SPECIFICATION NOTES.**
1. 100 x 20mm timber door set at 800mm above F.F.L.
  2. 100 x 20mm timber architrave set at 800mm above F.F.L.
  3. 170 x 150mm moulded cornice 450mm above F.F.L.
  4. 200 x 20mm timber architrave set at 800mm above F.F.L.
  5. 200 x 20mm timber architrave set at 800mm above F.F.L.
  6. Plaster & paint to match existing.
  7. 200 x 20mm timber architrave set at 800mm above F.F.L.
  8. 200 x 20mm timber architrave set at 800mm above F.F.L.
  9. Drywall partition to US slab.
  10. 400mm wide timber skirting on metal wall frame.
  11. 400mm wide timber skirting on metal wall frame.
  12. 200 x 20mm timber skirting to detail.
  13. 200 x 20mm timber skirting to detail.
  14. Chasing to be reconstructed to match existing.
  15. 20mm half round frosted timber frame.
  16. 20mm half round frosted timber frame.
  17. New ceiling to match existing.
  18. New doors to be provided to windows to replace existing.

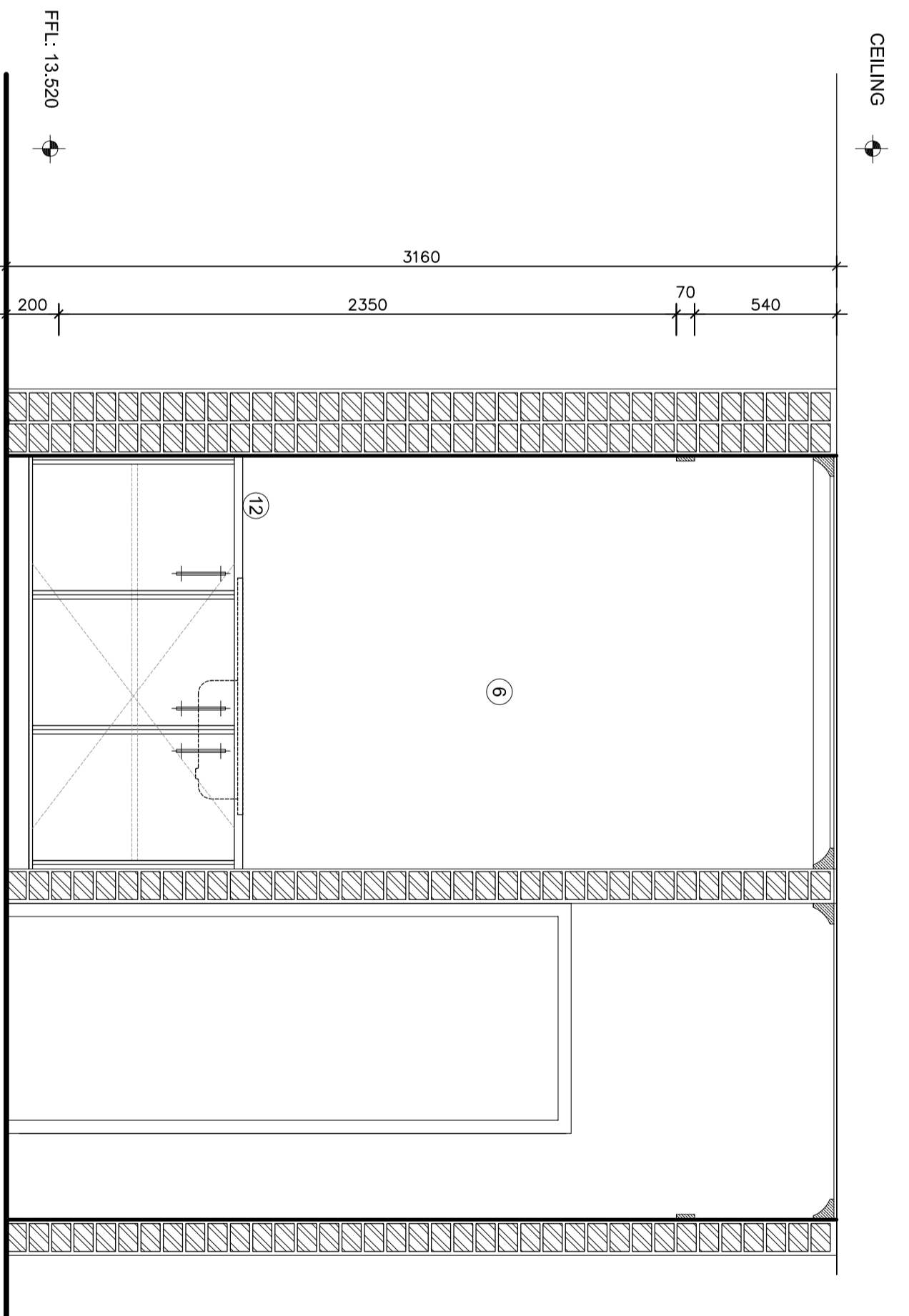

KITCHEN & TOILET - ELEVATION 3 (A)  
Scale 1:20

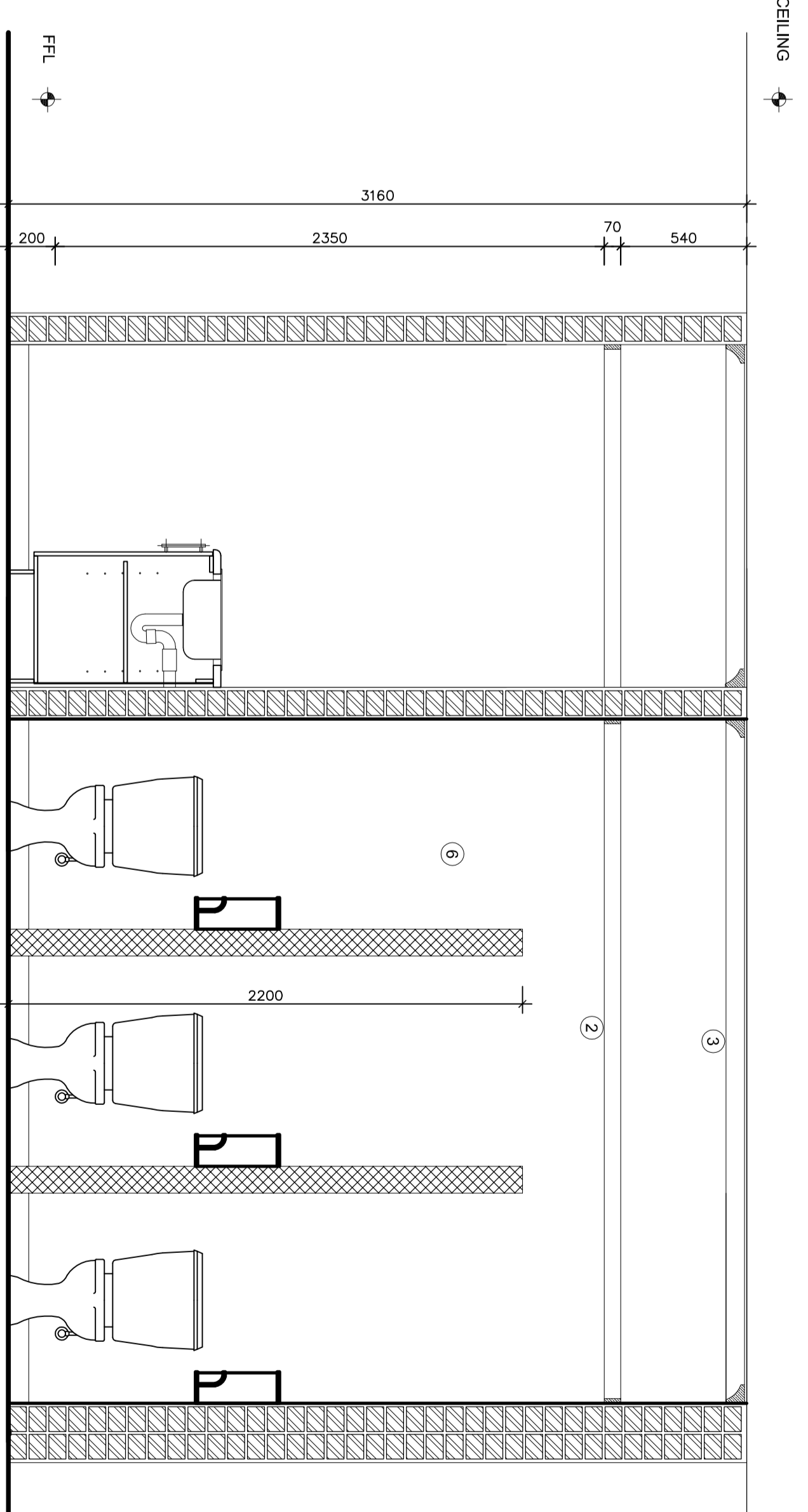

KITCHEN & TOILET - ELEVATION 4 (A)  
Scale 1:20

LOCATION PLAN

NO.	DATE	REVISIONS
1		ISSUE FOR TENDER / TENDERS
2		AMENDMENTS BEFORE CONTRACT COMMENCED
3		AMENDMENTS AFTER CONTRACT COMMENCED

**PROVINCE OF KWA-ZULU NATAL**  
**DEPARTMENT OF WORKS**  
 PRIVATE BAG X9041  
 PIETERMARITZBURG  
 3200



**L & R architects**  
 9 Wally Hayward Drive  
 Ashburton  
 Pietermaritzburg  
 3201  
 Tel: (+27) 33 326 1425  
 Fax: (+27) 86 670 8694  
 eMail: resen@lrvweb.co.za  
 eMail: admin@lrvweb.co.za

**PROJECT**  
 DEPARTMENT OF PUBLIC WORKS  
 KZN LEGISLATURE  
 REHABILITATION & RESTORATION  
 OF KZN LEGISLATURES LAW  
 SOCIETY BUILDING  
 WIMS 057929

**DRAWING DESCRIPTION**  
 KITCHEN & UPPER TOILET LAYOUT  
 INTERNAL ELEVATIONS

DRAWING NO.	REV
057929-L01-215	A
SCALE	1 : 20
DATE	25-01-2016
DRAWN	N.M.
CHECKED	
CLIENT	
WIMS 057929	