LICHTENBURG 2, NORTH WEST PROVINCE

ENVIRONMENTAL MANAGEMENT PROGRAMME:

Revision 1

November 2020

Prepared for

ABO Wind Lichtenburg 2 PV (Pty) Ltd
Unit B1 Mayfair Square
Century Way
Century City
7441

Prepared by:

Savannah Environmental (Pty) Ltd

First Floor, Block 2, 5 Woodlands Drive Office Park
Woodmead
Johannesburg, 2191
Tel: +27 (0)11 656 3237
Fax: +27 (0)86 684 0547
E-mail: info@savannahsa.com
www.savannahsa.com

savannah
environmental

PROJECT DETAILS

Title : Environmental Impact Assessment Process
Environmental Management Programme: Lichtenburg 2 PV
Facility, North West Province

DEA Ref. : 14/12/16/3/3/2/1092

Authors : Savannah Environmental
Lisa Opperman
Jo-Anne Thomas

Revised by: Reuben Maroga

Specialists : Nkurenkuru Ecology & Biodiversity
Pachnoda Consulting
Terra Africa Environmental Consultants
CTS Heritage
LOGIS
Savannah Environmental
Dr. Neville Bews and Associates
Knight Piésold

Applicant : ABO Wind Lichtenburg 2 PV (Pty) Ltd

Report Status : Environmental Management Programme Revision 1 as part of the
Part 2 Amendment Process undertaken for Lichtenburg 2
submitted to the competent authority for decision-making.

Date : November 2020

When used as a reference this report should be cited as: Savannah Environmental (2020). Environmental Management Programme – Revision 1: Lichtenburg 2 PV Facility, North West Province

COPYRIGHT RESERVED

This technical report has been produced for ABO Wind Lichtenburg 2 PV (Pty) Ltd. The intellectual property contained in this report remains vested in Savannah Environmental and ABO Wind Lichtenburg 2 PV (Pty) Ltd. No part of the report may be reproduced in any manner without written permission from ABO Wind Lichtenburg 2 PV (Pty) Ltd or Savannah Environmental (Pty) Ltd.

DEFINITIONS AND TERMINOLOGY

The following definitions and terminology may be applicable to this project and may occur in the report below:

Alien species: A species that is not indigenous to the area or out of its natural distribution range.

Alternatives: Alternatives are different means of meeting the general purpose and need of a proposed activity. Alternatives may include location or site alternatives, activity alternatives, process or technology alternatives, temporal alternatives or the 'do nothing' alternative.

Ambient sound level: The reading on an integrating impulse sound level meter taken at a measuring point in the absence of any alleged disturbing noise at the end of a total period of at least 10 minutes after such meter was put into operation.

Assessment: The process of collecting, organising, analysing, interpreting and communicating information which is relevant.

Biological diversity: The variables among living organisms from all sources including, terrestrial, marine and other aquatic ecosystems and the ecological complexes they belong to.

Commence: The start of any physical activity, including site preparation and any other activity on site furtherance of a listed activity or specified activity, but does not include any activity required for the purposes of an investigation or feasibility study as long as such investigation or feasibility study does not constitute a listed activity or specified activity.

Construction: Construction means the building, erection or establishment of a facility, structure or infrastructure that is necessary for the undertaking of a listed or specified activity as per the EIA Regulations. Construction begins with any activity which requires Environmental Authorisation.

Cumulative impacts: The impact of an activity that in itself may not be significant, but may become significant when added to the existing and potential impacts eventuating from similar or diverse activities or undertakings in the area.

Decommissioning: To take out of active service permanently or dismantle partly or wholly, or closure of a facility to the extent that it cannot be readily re-commissioned. This usually occurs at the end of the life of a facility.

Direct impacts: Impacts that are caused directly by the activity and generally occur at the same time and at the place of the activity (e.g. noise generated by blasting operations on the site of the activity). These impacts are usually associated with the construction, operation, or maintenance of an activity and are generally obvious and quantifiable.

Disturbing noise: A noise level that exceeds the ambient sound level measured continuously at the same measuring point by 7 dB or more.

'Do nothing' alternative: The 'do nothing' alternative is the option of not undertaking the proposed activity or any of its alternatives. The 'do nothing' alternative also provides the baseline against which the impacts of other alternatives should be compared.

Ecosystem: A dynamic system of plant, animal and micro-organism communities and their non-living environment interacting as a functional unit.

Endangered species: Taxa in danger of extinction and whose survival is unlikely if the causal factors continue operating. Included here are taxa whose numbers of individuals have been reduced to a critical level or whose habitats have been so drastically reduced that they are deemed to be in immediate danger of extinction.

Endemic: An "endemic" is a species that grows in a particular area (is endemic to that region) and has a restricted distribution. It is only found in a particular place. Whether something is endemic or not depends on the geographical boundaries of the area in question and the area can be defined at different scales.

Environment: the surroundings within which humans exist and that is made up of:

- i. The land, water and atmosphere of the earth;
- ii. Micro-organisms, plant and animal life;
- iii. Any part or combination of (i) and (ii) and the interrelationships among and between them; and
- iv. The physical, chemical, aesthetic and cultural properties and conditions of the foregoing that influence human health and well-being.

Environmental Authorisation (EA): means the authorisation issued by a competent authority (Department of Environmental Affairs) of a listed activity or specified activity in terms of the National Environmental Management Act (No 107 of 1998) and the EIA Regulations promulgated under the Act.

Environmental assessment practitioner (EAP): An individual responsible for the planning, management and coordinating of environmental management plan or any other appropriate environmental instruments introduced by legislation.

Environmental Control Officer (ECO): An individual appointed by the Owner prior to the commencement of any authorised activities, responsible for monitoring, reviewing and verifying compliance by the EPC Contractor with the environmental specifications of the EMPr and the conditions of the Environmental Authorisation

Environmental impact: An action or series of actions that have an effect on the environment.

Environmental impact assessment: Environmental Impact Assessment, as defined in the NEMA EIA Regulations, is a systematic process of identifying, assessing and reporting environmental impacts associated with an activity.

Environmental management: Ensuring that environmental concerns are included in all stages of development, so that development is sustainable and does not exceed the carrying capacity of the environment.

Environmental management programme: A plan that organises and co-ordinates mitigation, rehabilitation and monitoring measures in order to guide the implementation of a project or facility and its ongoing maintenance after implementation.

Habitat: The place in which a species or ecological community occurs naturally.

Hazardous waste: Any waste that contains organic or inorganic elements or compounds that may, owing to the inherent physical, chemical or toxicological characteristics of that waste, have a detrimental impact on health and the environment.

Indigenous: All biological organisms that occurred naturally within the study area prior to 1800.

Incident: An unplanned occurrence that has caused, or has the potential to cause, environmental damage.

Indirect impacts: Indirect or induced changes that may occur because of the activity (e.g. the reduction of water in a stream that supply water to a reservoir that supply water to the activity). These types of impacts include all the potential impacts that do not manifest immediately when the activity is undertaken or which occur at a different place because of the activity.

Interested and affected party: Individuals or groups concerned with or affected by an activity and its consequences. These include the authorities, local communities, investors, work force, consumers, environmental interest groups, and the public.

Method Statement: a written submission by the Contractor in response to the environmental specification or a request by the Site Manager, setting out the plant, materials, labour and method the Contractor proposes using to conduct an activity, in such detail that the Site Manager is able to assess whether the Contractor's proposal is in accordance with the Specifications and/or will produce results in accordance with the Specifications.

Photovoltaic effect: Electricity can be generated using photovoltaic panels (semiconductors) which are comprised of individual photovoltaic cells that absorb solar energy to produce electricity. The absorbed solar radiation excites the electrons inside the cells and produces what is referred to as the Photovoltaic Effect.

Pre-construction: The period prior to the commencement of construction, which may include activities which do not require Environmental Authorisation (e.g. geotechnical surveys).

Pollution: A change in the environment caused by substances (radio-active or other waves, noise, odours, dust or heat emitted from any activity, including the storage or treatment or waste or substances.

Rare species: Taxa with small world populations that are not at present Endangered or Vulnerable, but are at risk as some unexpected threat could easily cause a critical decline. These taxa are usually localised within restricted geographical areas or habitats or are thinly scattered over a more extensive range. This category was termed Critically Rare by Hall and Veldhuis (1985) to distinguish it from the more generally used word "rare."

Red Data Species: Species listed in terms of the International Union for Conservation of Nature and Natural Resources (IUCN) Red List of Threatened Species, and/or in terms of the South African Red Data list. In terms of the South African Red Data list, species are classified as being extinct, endangered, vulnerable, rare, indeterminate, insufficiently known or not threatened (see other definitions within this glossary).

Significant impact: An impact that by its magnitude, duration, intensity, or probability of occurrence may have a notable effect on one or more aspects of the environment.

Vulnerable species: A taxon is Vulnerable when it is not Critically Endangered or Endangered but is facing a high risk of extinction in the wild in the medium-term future.

Waste: as per the NEM: Waste Amendment Act, 2014 (Act No. 26 of 2014)

(a) any substance, material or object, that is unwanted, rejected, abandoned, discarded or disposed of, or that is intended or required to be discarded or disposed of, by the holder of that substance, material or object, whether or not such substance, material or object can be re-used, recycled or recovered and includes all wastes as defined in Schedule 3.

(b) any other substance, material or object that is not included in Schedule 3 that may be defined as waste by the Minister by notice in the Gazette,

but any waste or portion of waste, referred to in paragraph (a) and (b), ceases to be a waste –

(i) once an application for its re-use, recycling or recovery has been approved or, after such approval, once it is, or has been re-used, recycled or recovered;

(ii) where approval is not required, once a waste is, or has been re-used, recycled or recovered;

(iii) where the Minister has, in terms of section 74, exempted any waste or a portion of waste generated by a particular process from the definition of waste; or

where the Minister has, in the prescribed manner, excluded any waste stream or a portion of a waste stream from the definition of waste.

ABBREVIATIONS

The following abbreviations may be applicable to this project and may occur in the report below:

AIA	Archaeological Impact Assessment
BGIS	Biodiversity Geographic Information System
CDSM	Chief Directorate Surveys and Mapping
CEMP	Construction Environmental Management Plan
DBAR	Draft Basic Assessment Report
DEA	Department of Environmental Affairs
<u>DEFF</u>	<u>Department of Environment, Forestry and Fisheries</u>
<u>DMRE</u>	<u>Department of Mineral Resources and Energy</u>
DME	Department of Minerals and Energy
EAP	Environmental Impact Practitioner
EHS	Environmental, Health and Safety
EIA	Environmental Impact Assessment
EIR	Environmental Impact Report
EMPr	Environmental Management Programme
GPS	Global Positioning System
GWh	Giga Watt hour
HIA	Heritage Impact Assessment
I&APs	Interested and Affected Parties
IDP	Integrated Development Plan
IFC	International Finance Corporation
IPP	Independent Power Producer
KNP	Karoo National Park
KOP	Key Observation Point
kV	Kilo Volt
LAeq,T	Time interval to which an equivalent continuous A-weighted sound level
LLRC	Low Level River Crossing
LUDS	Land Use Decision Support
LUPO	Land Use Planning Ordinance
MW	Mega Watt
NEMA	National Environmental Management Act
NEMAA	National Environmental Management Amendment Act
NEMBA	National Environmental Management: Biodiversity Act
NERSA	National Energy Regulator of South Africa
NHRA	National Heritage Resources Act
NID	Notice of Intent to Develop
NSBA	National Spatial Biodiversity Assessment
NWA	National Water Act
PIA	Paleontological Impact Assessment
PM	Post Meridiem; "Afternoon"
SACAA	South African Civil Aviation Authority
SAHRA	South African National Heritage Resources Agency
SANBI	South Africa National Biodiversity Institute

SANS	South Africa National Standards
SDF	Spatial Development Framework
SMME	Small, Medium and Micro Enterprise
SAPD	South Africa Police Department

TABLE OF CONTENTS

	PAGE
PROJECT DETAILS	i
DEFINITIONS AND TERMINOLOGY	ii
TABLE OF CONTENTS	viii
CHAPTER 1: INTRODUCTION	1
CHAPTER 2: PROJECT DETAILS	3
2.1 Project Site.....	3
2.2 Project Description	4
2.3 Activities and Components Associated with the PV Facility	7
2.3.1 Design and Pre-Construction Phase	7
2.3.2 Construction Phase	7
2.3.3 Operation Phase	9
2.3.4 Decommissioning Phase	9
2.4 Findings of the Environmental Impact Assessment (EIA)	10
2.4.1 Impacts on Ecology and Hydrology	10
2.4.2 Impacts on Avifauna	11
2.4.3 Impacts on Land Use, Soil and Agricultural Potential	11
2.4.4 Impacts on Heritage Resources	12
2.4.5 Visual Impacts	12
2.4.6 Social Impacts	13
2.4.7 Impacts on Traffic	14
2.5 Environmental Sensitivity.....	14
2.6 Contents of this Environmental Management Programme (EMPr).....	18
2.7 Project Team	20
2.7.1 Details and Expertise of the Environmental Assessment Practitioner (EAP)	21
2.7.2 Details of the Specialist Consultants	22
CHAPTER 3 : PURPOSE AND OBJECTIVES OF THE EMPr	23
CHAPTER 4: STRUCTURE OF THIS EMPr	25
CHAPTER 5: PLANNING AND DESIGN MANAGEMENT PROGRAMME	27
5.1 Objectives	27
OBJECTIVE 1: Ensure the facility design responds to identified environmental constraints and opportunities	27
OBJECTIVE 2: Ensure the selection of the best environmental option for the alignment of the power line and underground cabling	32
OBJECTIVE 3: Minimise stormwater runoff.....	34
OBJECTIVE 4: To ensure effective communication mechanisms	34
OBJECTIVE 5: Ensure that all relevant personnel and staff are familiar with the provisions of the EMPr, as well as the conditions of the Environmental Authorisation and requirement for environmental preservation	35
CHAPTER 6: MANAGEMENT PROGRAMME: CONSTRUCTION	37
6.1 Institutional Arrangements: Roles and Responsibilities for the Construction Phase.....	37
OBJECTIVE 1: Establish clear reporting, communication, and responsibilities in relation to the overall implementation of the EMPr	37
6.2 Objectives	41
OBJECTIVE 2: Minimise impacts related to inappropriate site establishment	41

OBJECTIVE 3: Appropriate management of the construction site and construction workers	43
OBJECTIVE 4: Maximise local employment and business opportunities associated with the construction phase	46
OBJECTIVE 5: Maximise capacity building and skills training, and address economic inequities within the study area	47
OBJECTIVE 6: Minimise the impact of the inflow of an outside workforce and job seekers into the study area.....	49
OBJECTIVE 7: Minimise impacts related to traffic management and transportation of equipment and materials to site	50
OBJECTIVE 8: Minimise the potential impact on health, safety and security	52
OBJECTIVE 9: Minimise the potential impact on the daily living and movement patterns.....	53
OBJECTIVE 10: Minimisation of the development footprint and disturbance of topsoil.....	56
OBJECTIVE 11: Minimise soil degradation and erosion and loss of land capability	58
OBJECTIVE 12: Minimise the impacts on and loss of indigenous vegetation	60
OBJECTIVE 13: Minimise the establishment and spread of alien invasive plants	61
OBJECTIVE 14: Minimise the impacts on fauna	63
OBJECTIVE 15: Appropriate Stormwater Management	65
OBJECTIVE 16: Protection of heritage resources	66
OBJECTIVE 17: Appropriate handling and management of waste.....	68
OBJECTIVE 18: Appropriate handling and storage of chemicals, hazardous substances	70
OBJECTIVE 19: Limit direct and indirect terrestrial faunal and avifaunal impacts	73
OBJECTIVE 20: Effective management of concrete batching plants	74
OBJECTIVE 21: Enhancement of positive social impacts and mitigation of negative social impacts	76
6.3 <i>Detailing Method Statements</i>	78
OBJECTIVE 22: Ensure all construction activities are undertaken with the appropriate level of environmental awareness to minimise environmental risk	78
6.4 <i>Awareness and Competence: Construction Phase</i>	80
OBJECTIVE 23: To ensure all construction personnel have the appropriate level of environmental awareness and competence to ensure continued environmental due diligence and on-going minimisation of environmental harm	80
6.4.1 <i>Environmental Awareness and Induction Training</i>	81
6.4.2 <i>Toolbox Talks</i>	82
6.5 <i>Monitoring Programme: Construction Phase</i>	82
OBJECTIVE 24: To monitor the performance of the control strategies employed against environmental objectives and standards.....	82
6.5.1. <i>Non-Conformance Reports</i>	83
6.5.2. <i>Monitoring Reports</i>	83
6.5.3. <i>Audit Reports</i>	83
6.5.4. <i>Final Audit Report</i>	83
CHAPTER 7: MANAGEMENT PROGRAMME: REHABILITATION	84
7.1. <i>Objectives</i>	84
OBJECTIVE 1: Ensure appropriate rehabilitation of disturbed areas such that residual environmental impacts are remediated or curtailed	84
CHAPTER 8: OPERATION MANAGEMENT PROGRAMME	87
8.1. <i>Objectives</i>	87
OBJECTIVE 1: Establish clear reporting, communication, and responsibilities in relation to overall implementation of the EMPr during operation	87

OBJECTIVE 2: Protection of indigenous natural vegetation, fauna and maintenance of rehabilitation.. 88

OBJECTIVE 3: Protection of avifauna from collision and electrocution..... 90

OBJECTIVE 4: Minimise soil degradation, erosion and alien plant invasion 92

OBJECTIVE 5: Minimise dust and air emissions..... 93

OBJECTIVE 6: Ensure the implementation of an appropriate fire management plan and general management measures during the operation phase..... 95

OBJECTIVE 7: Minimise the potential impact on farming activities and on the surrounding landowners.. 97

OBJECTIVE 8: Appropriate handling and management of hazardous substances, waste and dangerous goods 98

OBJECTIVE 9: Enhancement of positive social impacts and mitigation of negative social impacts 100

CHAPTER 9: MANAGEMENT PROGRAMME: DECOMMISSIONING 102

9.1. Objectives 102

9.2. Approach to the Decommissioning Phase 103

9.2.1. Identification of structures for post-closure use 104

9.2.2. Removal of infrastructure 104

9.2.3. Soil rehabilitation 104

9.2.4. Establishment of vegetation 104

9.2.5. Maintenance 104

9.2.6. Monitoring 104

APPENDICES

Appendix A:	Layout and Sensitivity Maps
Appendix B:	Grievance Mechanism for Public Complaints and Issues
Appendix C:	Open Space Management Plan
Appendix D:	Re-vegetation and Rehabilitation Plan
Appendix E:	Plant Rescue and Protection Plan
Appendix F:	Traffic Management Plan
Appendix G:	Stormwater and Erosion Management Plan
Appendix H:	Waste Management Plan
Appendix I:	Emergency Preparedness, Response and Fire Management Plan
Appendix J:	Curriculum Vitae
Appendix K:	Key Legislation

CHAPTER 1: INTRODUCTION

This Environmental Management Programme has been compiled for the Lichtenburg 2 PV Facility. The project site identified for Lichtenburg 2 comprises a single privately-owned agricultural property (i.e. Portion 23 of the Farm Houthaalboomen No. 31). The project site is located approximately 10km north of Lichtenburg and 7.5km south of Bakerville, and falls within Ward 16 of the Ditsobotla LM, of the Ngaka Modiri Molema DM, in the North West Province. Access to the site is obtained directly via the R505 regional road, which traverses the eastern half of the project site in a north-west to south-east direction. Lichtenburg 2 will be designed to have a contracted capacity of up to 100MW, and will make use of photovoltaic (PV) solar technology.

This EMPr has been developed and updated on the basis of the findings of the Environmental Impact Assessment (EIA) as well as the Part 2 Amendment Process undertaken to include the construction and operation of a Battery Energy Storage System (BESS) within the authorised laydown area of Lichtenburg 2. Changes made to this EMPr have been underlined for ease of reference. The general purpose and utilisation of the BESS is to save and store excess electrical output as it is generated, allowing for a timed release when the capacity is required. In addition, the BESS will also provide grid strengthening and quality improvement, frequency control and voltage stabilisation. BESS systems therefore provide flexibility in the efficient operation of the electricity grid through decoupling of the energy supply and demand. The BESS is envisaged to become an integral component of the authorised solar energy facility, allowing for the storage of energy and extension of the generation period of the solar energy facility.

This EMPr has been developed on the basis of the findings of the Environmental Impact Assessment (EIA), and must be implemented to protect sensitive on-site and off-site features through controlling construction, operation and decommissioning activities that could have a detrimental effect on the environment, and through avoiding or minimising potential impacts. This EMPr is applicable to all ABO Wind Lichtenburg 2 PV (Pty) Ltd employees and contractors working on the pre-construction, construction, and operation and maintenance phases of Lichtenburg 2 (including the BESS). The document must be adhered to and updated as relevant throughout the project life cycle. This document fulfils the requirement of the EIA Regulations, 2014 (as amended) and forms part of the EIA Report and the Motivation Report of the project.

Due to the demand in the utilisation of battery energy storage systems for renewable energy projects, as well as to ensure an adequate supply of electricity to the national grid, ABO Wind Lichtenburg 2 PV (Pty) Ltd has proposed the construction and operation of a BESS with a capacity of up to 500MW/500MWh. Therefore, the EMPr includes an updated layout in response to construction and operation of the BESS within the authorised footprint of Lichtenburg 2 and to minimise impacts on the environment. The updated layout was informed by the findings of the specialists into the Part 2 Amendment process as well as the technical considerations for the project. The updated layout includes the BESS development footprint within the authorised laydown area of Lichtenburg 2. The extent of the BESS development footprint is no more than 5ha.

In terms of the Duty of Care provision in S28(1) the project proponent must ensure that reasonable measures are taken throughout the life cycle of this project to ensure that any pollution or degradation of the environment associated with this project is avoided, halted or minimised. In terms of NEMA, it has become the legal duty of a project proponent to consider a project holistically, and to consider the cumulative effect

of a variety of impacts. While no permitting or licensing requirements arise directly by virtue of Lichtenburg 2, this section will be applicable throughout the life cycle of the project.

CHAPTER 2: PROJECT DETAILS

ABO Wind Lichtenburg 2 PV (Pty) Ltd, a Special Purpose Vehicle (SPV) established by ABO Wind Renewable Energies (Pty) Ltd, proposes the development of Lichtenburg 2, a PV facility (including a BESS) and associated infrastructure on a site near Lichtenburg, in the North West Province. Lichtenburg 2 comprises a commercial solar energy facility and is intended to form part of the Risk Mitigation Independent Power Producer (IPP) Procurement Programme and/or Renewable Energy Independent Power Producer Procurement Programme (REIPPPP) of the Department of Mineral Resources and Energy (DMRE) and/or any future relevant procurement programme. The REIPPPP Programme aims to secure 14 725MW¹ of new generation capacity from Renewable Energy (RE) sources (in accordance with South Africa's Integrated Resource Plan for Electricity (IRP) 2010 – 2030), while simultaneously diversifying South Africa's electricity mix, and positively contributing towards socio-economic, and environmentally sustainable growth. Lichtenburg 2 will be designed to have a contracted capacity of up to 100MW, and will make use of photovoltaic (PV) solar technology.

2.1 Project Site

Lichtenburg 2 is proposed on Portion 23 of the Farm Houthaalboomen No. 31, which is located approximately 10km north of Lichtenburg and 7.5km south of Bakerville. The project site identified for Lichtenburg 2 comprises a single privately-owned agricultural property, and falls within Ward 16 of the Ditsobotla Local Municipality, of the Ngaka Modiri Molema District Municipality, in the North West Province. Access to the site is obtained directly via the R505 regional road, which traverses the eastern half of the project site in a north-west to south-east direction.

Table 2.1 provides information regarding the proposed project site identified for Lichtenburg 2 and the associated infrastructure

Table 2.1: A description of the project site identified for Lichtenburg 2

Province	North West Province
District Municipality	Ngaka Modiri Molema District Municipality
Local Municipality	Ditsobotla Local Municipality
Ward Number(s)	Ward 16
Nearest Town(s)	<ul style="list-style-type: none"> » Lichtenburg (approximately 10km south of the project site) » Bakerville (approximately 7.5km north of the project site)
Farm Portion(s), Name(s) and Number(s)	<p>Lichtenburg 2:</p> <ul style="list-style-type: none"> » Portion 23 of the Farm Houthaalboomen No. 31 <p>Preferred Power Line Corridor:</p> <ul style="list-style-type: none"> » Portion 23 of the Farm Houthaalboomen No. 31 » Remaining Extent of Portion 02 of the Farm Zamenkomst No. 04
SG 21 Digit Code (s)	<p>Lichtenburg 2:</p> <ul style="list-style-type: none"> » TOIP00000000003100023 <p>Preferred Power Line Corridor:</p> <ul style="list-style-type: none"> » TOIP00000000003100023 » TOIP0000000000400002

¹ Source: <https://www.ipp-renewables.co.za/>

Current Zoning	Agriculture
Current land use	Agriculture
Site Extent (affected property size)	Lichtenburg 2: » 496ha Preferred Power Line Corridor: » 496ha » 429ha

2.2 Project Description

The proposed project will have a contracted capacity of up to 100MW, and will make use of PV solar technology for the generation of electricity. The project will comprise the following key infrastructure and components:

- » Arrays of PV solar panels with a contracted capacity of up to 100MW.
- » Mounting structures to support the PV panels (utilising either fixed-tilt / static, single-axis tracking, or double-axis tracking systems).
- » On-site inverters to convert power from Direct Current (DC) to Alternating Current (AC), and a 88/132kV on-site substation to facilitate the connection between the solar facility and the Eskom grid connection point.
- » A new 88/132kV power line between the on-site substation and the Eskom grid connection point. A Loop-in / Loop-out to the existing Mmabatho/ Watershed DS 2 88kV power line traversing east of the project site is preferred from an environmental perspective.
- » Electrochemical battery energy storage systems (BESS) (including either Lead Acid and Advanced Lead Acid, NiCd, NiMh-based batteries, Temperature (NaS, Na-NiCl₂, Mg/Pb-Sb) batteries or Flow batteries or Flow batteries (VRFB, Zn-Fe, Zn-Br)) with a maximum height of 3.5m and a capacity of up to 500MW/500MWh;
- » Multi-core, 33kV underground cables to follow internal access roads of the PV facility, to connect the battery energy storage system to the on-site facility substation;
- » Cabling between the project's components, to be laid underground where practical.
- » Auxiliary buildings such as offices and workshop areas for maintenance and storage.
- » Temporary laydown areas required during construction.
- » Internal access roads and perimeter security fencing around the development area.

A summary of the associated infrastructure proposed as part of Lichtenburg 2 is provided in **Table 2.2**, and described in more detail under the sub-headings below.

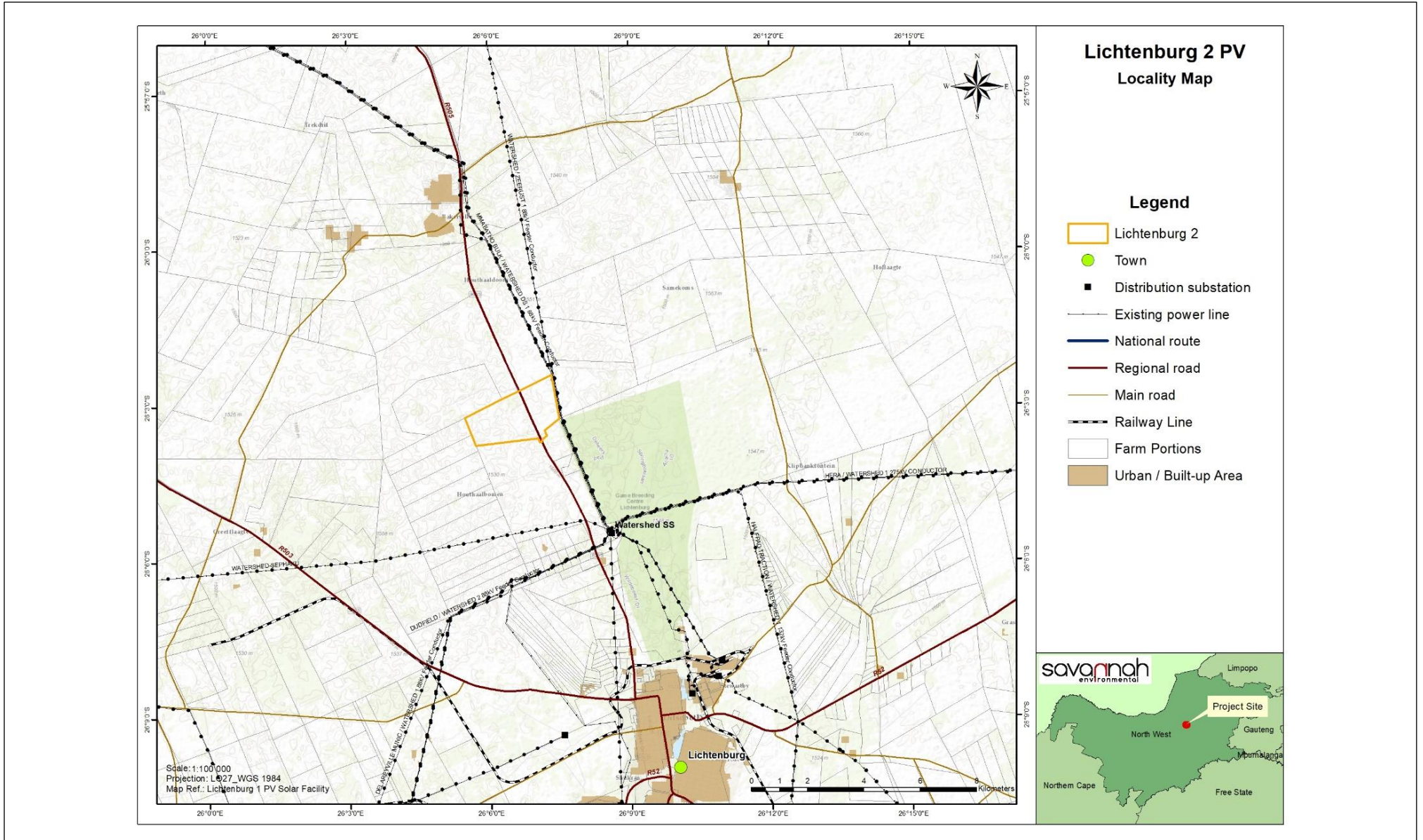

Figure 2.1: Locality map illustrating the location of the project site proposed for the establishment of Lichtenburg 2

Table 2.2: Planned infrastructure proposed as part of Lichtenburg 2

Infrastructure	Dimensions/ Details
Solar Facility	<ul style="list-style-type: none"> » PV technology. » Solar panels approximately 3.5m in height. » Centralised inverter stations approximately 3m in height, or string inverters mounted approximately 0.3m above ground. » Fixed-tilt, single-axis tracking, or double-axis tracking systems. » PV structures / modules approximately 170ha in extent for Alternative 1 (preferred) or approximately 255ha in extent for Alternative 2.
Supporting Infrastructure	<ul style="list-style-type: none"> » Gate house and security building of ~6m x6m. » Control Centre of ~31m x 8m. » Office Building of ~22m x 11m. » 2 x Warehouses of ~50m x 20m each. » Canteen and Visitors Centre of ~30m x 10m. » Rainwater tanks with a capacity of 10 000l. » Perimeter fencing.
<u>Battery Energy Storage System (BESS)</u>	<ul style="list-style-type: none"> » <u>Electrochemical battery energy storage systems (including either Lead Acid and Advanced Lead Acid, NiCd, NiMh-based batteries; Temperature (NaS, Na-NiCl₂, Mg/Pb-Sb) batteries or Flow batteries (VRFB, Zn-Fe, Zn-Br)) with a maximum height of 3.5m; and</u> » <u>Multi-core, 33kV underground cables, to follow internal access roads of the PV facility, to connect the battery storage system to the on-site facility substation.</u>
On-site substation	<ul style="list-style-type: none"> » On-site substation with a 88/132kV capacity. » Will occupy an area up to 1ha in extent.
Grid Connection	<ul style="list-style-type: none"> » A single 88/132kV power line is required for grid connection. » The power line servitude will be up to 36m in width (i.e. up to 18m on either side of the centre line of the power line). » The PV facility will be connected to the existing Mmabatho/Watershed DS 2 88kV power line traversing east of the project property. A Loop-in / Loop-out connection will be established. » Towers required to support the power line will be approximately 24m in height and will comprise monopole or lattice structures.
Access road	<ul style="list-style-type: none"> » Access to the proposed site will be via the R505 regional road which traverses the eastern half of the project site in a north-west to south-east direction. » Permanent access roads will be constructed as follows: <ul style="list-style-type: none"> * Main access road – 10m wide (to be tarred if necessary). * Internal access road – 5m wide and up to 1km in length (to be gravel, unless where / if specific sections required to be tarred). * Internal access roads will occupy approximately 10ha.
Water Supply	<ul style="list-style-type: none"> » Approximately 10 000m³ of water per year is required during construction (18 months). » Approximately 5 000m³ of water per year is required for operation (20 years). » The following water supply options are currently being considered (in order of preference): <ul style="list-style-type: none"> * Sourcing water from the Ditsobotla Local Municipality. * Sourcing water from another third-party water supplier. * Sourcing water from a borehole drilled on site. * All of the above supplemented by rainwater collection on site.

2.3 Activities and Components Associated with the PV Facility

A series of activities are proposed as part of the design, pre-construction, construction, operation, and decommissioning phases associated with the development of Lichtenburg 2. These are discussed in more detail under the respective sub-headings below.

2.3.1 Design and Pre-Construction Phase

Pre-planning

Several post-authorisation factors are expected to influence the final design of the facility and could result in small-scale modifications of the PV array or associated infrastructure. While an objective of the EPC Contractor, who will be responsible for the overall construction of the project, will be to comply with the approved facility design as far as possible, it should be understood that the construction process is dynamic and that unforeseen changes to the project specifications may take place. The EIA Report and the Motivation Report therefore describe the project in terms of the best available knowledge at the time. The final facility design is required to be approved by the DEFF². Importantly, should there be any substantive changes or deviations from the original scope or layout of the project, the DEFF will need to be notified and where relevant, approval obtained.

Conduct Surveys

Prior to initiating construction, a number of surveys will be required including, but not limited to confirmation of the micro-siting footprint (i.e. the precise location of the PV panels, BESS, substation and the associated infrastructure) and a geotechnical survey. Geotechnical surveys are executed by geotechnical engineers and geologists to acquire information regarding the physical characteristics of soil and rocks underlying a proposed project site. The purpose is to design earthworks and foundations for structures and to execute earthwork repairs necessitated due to changes in the subsurface environment.

2.3.2 Construction Phase

The construction phase will take approximately 18 months to complete, and will entail a series of activities including:

Procurement and employment

At the peak of construction the proposed project is likely to create a maximum of 400 employment opportunities. These employment opportunities will be temporary, and will last for a period of approximately 18 months (i.e. the length of construction). Employment opportunities generated during the construction phase will include low skilled, semi-skilled, and skilled opportunities. Solar PV projects make use of large numbers of unskilled and semi-skilled labour so there will be good opportunity to use local labour. Employment opportunities for the proposed solar energy facility will peak during the construction phase and significantly decline during the operation phase. The injection of income into the area in the form of wages will represent an opportunity for the local economy and businesses in the area.

The majority of the labour force is expected to be sourced from the surrounding towns, and no labour will be accommodated on-site during the construction period.

² Previously known as the Department of Environmental Affairs (DEA)

Establishment of an Access Road to the Site

Access to the project site will be established for the construction of the facility. Access to the project site is possible through the use of existing unsurfaced farm roads, which can be accessed from the R505 regional road. The most appropriate access route will be utilised for the solar facility. Within the facility development footprint itself, access will be required from new / existing roads for construction purposes (and limited access for maintenance during operation). The final layout will be determined following the identification of site related sensitivities.

Undertake Site Preparation

Site preparation activities will include clearance of vegetation. These activities will require the stripping of topsoil which will need to be stockpiled, backfilled and / or spread on site.

Transport of Components and Equipment to Site

The national, regional, secondary and proposed internal access roads will be used to transport all components and equipment required during the construction phase of the solar facility. Some of the components (i.e. substation transformer) may be defined as abnormal loads in terms of the National Road Traffic Act (No. 93 of 1996) (NRTA)³ by virtue of the dimensional limitations. Typical civil engineering construction equipment will need to be brought to the site (e.g. excavators, trucks, graders, compaction equipment, cement trucks, etc.) as well as components required for the mounting of the PV support structures, construction of the substation and site preparation.

Establishment of Laydown Areas on Site

Laydown and storage areas will be required for typical construction equipment. Once the required equipment has been transported to site, a dedicated equipment construction camp and laydown area will need to be established adjacent to the workshop area. The equipment construction camp serves to confine activities and storage of equipment to one designated area to limit the potential ecological impacts associated with this phase of the development. The laydown area will be used for the assembly of the PV panels and the general placement / storage of construction equipment. A temporary laydown area approximately 5ha in extent is required during construction. The temporary laydown area will be included within the development footprint of the facility. The BESS components will be assembled off-site and delivered to the project site for installation. The BESS will be developed within the laydown area of the solar energy facility.

Erect PV Cells and Construct Substation and Invertors

The construction phase involves installation of the PV solar panels and structural and electrical infrastructure required for the operation of the facility. In addition, preparation of the soil and improvement of the access roads is likely to continue for most of the construction phase. For array installations, vertical support posts are driven into the ground. Depending on the results of the geotechnical report, a different foundation method, such as screw pile, helical pile, micropile or drilled post / pile could be used. The posts will hold the support structures (tables) on which the PV modules would be mounted. Brackets attach the PV modules to the tables. Trenches are dug for the underground AC and DC cabling and the foundations of the inverter enclosures and transformers are prepared. While cables are being laid and combiner boxes are being installed, the PV tables are erected. Wire harnesses connect the PV modules to the electrical collection

³ A permit will be required in accordance with Section 81 of the NRTA which pertains to vehicles and loads which may be exempted from provisions of the Act.

systems. Underground cables and overhead circuits connect the Power Conversion Stations (PCS) to the on-site AC electrical infrastructure and ultimately the solar facility's on-site substation.

The construction of the substation will require a survey of the site, site clearing and levelling and construction of access road(s) (where applicable), construction of a level terrace and foundations, assembly, erection, installation and connection of equipment, and rehabilitation of any disturbed areas, and protection of erosion sensitive areas. Following the completion of the construction of the substation, the BESS will be placed and connected to the substation by underground cables to follow internal access roads.

Establishment of Ancillary Infrastructure

Ancillary infrastructure will include a power line for connection to the Eskom national grid, workshop, storage and laydown areas, gatehouse and security complex, as well as a temporary contractor's equipment camp.

The establishment of the ancillary infrastructure and support buildings will require the clearing of vegetation and levelling of the development site, and the excavation of foundations prior to construction. Laydown areas for building materials and equipment associated with these buildings will also be required.

Construction of the power line

A power line is constructed by surveying the power line route, constructing foundations for the towers, installing the towers, stringing the conductors, and finally rehabilitating disturbed areas and protecting erosion sensitive areas.

Undertake Site Rehabilitation

Once construction is completed and all construction equipment has been removed, the site will be rehabilitated where practical and reasonable. In addition, on full commissioning of the solar facility, any access points which are not required during operation must be closed and rehabilitated accordingly.

2.3.3 Operation Phase

The proposed solar facility is expected to operate for a minimum of 20 years. The facility will operate continuously, 7 days a week, during daylight hours. While the solar facility will be largely self-sufficient, monitoring and periodic maintenance activities will be required. Key elements of the Operation and Maintenance (O&M) plan include monitoring and reporting the performance of the solar facility, conducting preventative and corrective maintenance, receiving visitors, and maintaining security.

2.3.4 Decommissioning Phase

Depending on the continued economic viability of the solar farm following the initial 20-year operational lifespan, the operation phase will be extended or the facility will either be decommissioned. If it is deemed financially viable to extend the operation phase, existing components would either continue to operate, or be disassembled and replaced with new, more efficient technology / infrastructure available at the time. If the decision is made to decommission the solar facility, the following decommissioning activities will take place:

Site Preparation

Site preparation activities include confirming the integrity of the access to the site to accommodate the required decommissioning equipment.

Disassembly and Removal of Existing Components

When the solar facility is ultimately decommissioned, the equipment to be removed will depend on the land use proposed for the site at the time. All above ground facilities that are not intended for future use at the site will be removed. Much of the above ground wire, steel, and PV panels of which the system is comprised, are recyclable materials and would be recycled to the extent feasible. The components of the solar facility would be deconstructed and recycled, or disposed of in accordance with applicable regulatory requirements. The site will be rehabilitated and can be returned to agriculture or another beneficial land-use.

Future plans for the site and infrastructure after decommissioning

The generation capacity of the facility would have degraded by approximately 15% over the 20-year operations lifespan. The solar facility will potentially have the opportunity to generate power for a Merchant Market operation (i.e. the client would sell power on a bid basis to the market). Another option for the site after decommissioning is for agricultural activities to resume.

2.4 Findings of the Environmental Impact Assessment (EIA)

No environmental fatal flaws were identified in the detailed specialist studies conducted, provided that the recommended mitigation measures are implemented. These measures include, amongst others, the avoidance of sensitive features within the development footprint and the undertaking of monitoring, as specified by the specialists.

The potential environmental impacts associated with Lichtenburg 2 that were identified and assessed through the EIA process include:

- » Impacts on ecology, flora, fauna and hydrological features.
- » Impacts on avifauna.
- » Impacts to soils, land-use and agricultural potential.
- » Impacts on heritage resources, including archaeology and palaeontology.
- » Visual impacts on the area imposed by the components of the facility.
- » Positive and negative socio- economic impacts.
- » Traffic impacts.

2.4.1 Impacts on Ecology and Hydrology

The Ecological and Hydrological Impact Assessment assessed the impact of Lichtenburg 2 on the sensitive ecological and hydrological⁴ features present within the project site for the life-cycle of the project. The assessment identified impacts within the construction and operation phases of the project.

⁴ It must be noted that no sensitive hydrological features have been identified and confirmed within the Lichtenburg 2 project site by the specialist.

During the construction phase, the impacts expected to occur include impacts on vegetation and listed protected plant species, faunal impacts, an increased erosion risk and increased alien plant invasion. The significance of the construction phase impacts ranges from medium to low, following the implementation of the recommended mitigation measures by the specialist. No impacts of a high significance were identified prior to the implementation of mitigation.

During the operation phase, the anticipated impacts include altered runoff patterns due to rainfall interception by the PV panel infrastructure and compacted areas resulting in high levels of erosion, increased alien plant invasion, an increased erosion risk and faunal impacts. The significance of the impacts for the operation phase ranges from medium to low, following the implementation of the recommended mitigation measures by the specialist. No impacts of a high significance were identified for the project.

From the findings of the Ecological and Hydrological Impact Assessment (**Appendix D** of the EIA Report) it can be concluded that no impacts of high ecological or hydrological significance were identified which would hinder the development of Lichtenburg 2 and its associated infrastructure within the project site. The proposed development is considered to be appropriate and acceptable from an ecological and surface hydrological perspective and will not result in detrimental impacts to ecosystems and habitat features present within the project site and within the surrounding properties. The specialist has therefore indicated that the development may be authorised, constructed and operated, subject to the implementation of the recommended mitigation measures.

2.4.2 Impacts on Avifauna

The Avifauna Impact Assessment (**Appendix E** of the EIA Report) is based on the findings of point count sampling techniques applied during two site visits undertaken in July 2018 and October 2018 (i.e. wet and dry season site visits). The avifauna impacts identified to be associated with Lichtenburg 2 will be negative and local to regional in extent. The duration of the impacts will be medium to long-term, for the lifetime of the PV facility.

During the construction phase of Lichtenburg 2, a loss of habitat due to clearance of vegetation is expected to occur. The significance of this impact can be reduced to low with the implementation of the recommended mitigation measures provided by the specialist.

Majority of the avifauna impacts associated with the development of Lichtenburg 2 will occur during the operation phase. These impacts include the creation of "new" avian habitat which refers to the creation of novel habitat for commensal or superior competitive bird species, the electrocution of birds due to the associated power line and collision with the PV panels and power line. The significance of the impacts will be low to medium, with the exception of a high significance for the impact of avian collision with the power line.

From the results of the avifauna assessment, it can be concluded that no fatal-flaws will be associated with the development of Lichtenburg 2 from an avifaunal perspective.

2.4.3 Impacts on Land Use, Soil and Agricultural Potential

The proposed Lichtenburg 2 project infrastructure is located on shallow, rocky soils with low to moderate-low land capability. The construction and operation of a PV facility on the project site is considered acceptable

from a soils perspective as it will supplement and stabilise the landowner's income in an area where farming is susceptible to periodic droughts. Centre pivot irrigation areas, where good crop yields are obtained, have been avoided by the development infrastructure associated with Lichtenburg 2.

Impacts have been identified for both the construction and operation phases for Lichtenburg 2 (**Appendix F** of the EIA Report). The impacts associated with land use, soil and agricultural potential include an increased risk of soil erosion, potential chemical pollution and loss of land capability. The significance of the impacts ranges from low to medium with the implementation of the mitigation measures recommended by the specialist.

2.4.4 Impacts on Heritage Resources

The project site has been disturbed and transformed by agricultural activities which has led to the presence of pre-existing agricultural plough fields, grazing areas and farm buildings. Furthermore, throughout the agricultural areas within the project site, several heaps of rocks that have been removed from the agricultural fields were identified. No archaeological resources, graves or burial grounds were identified within the project site. In addition, no structures of heritage importance were recorded.

Considering the palaeontology of the project site, it was identified that the area in question is located within the Malmani Group which contains a number of stromatolitic dolomites. The geological structures of the project site suggest that the rocks are much too old to contain fossils other than blue-green algae. Taking account of the defined criteria, the potential impact to fossil heritage resources is negligible to extremely low.

The Heritage Impact Assessment (**Appendix H** of the EIA Report) identified impacts associated with the construction and operation of Lichtenburg 2. The impact on heritage resources include the archaeology and palaeontology of the project site.

Impacts on palaeontological and archaeological resources are expected to occur during the construction phase of Lichtenburg 2. The impacts relate to the excavations required for the construction of the facility and will occur only in the event that an archaeological or palaeontological resource is present. The significance of the impact will be low and no mitigation has been recommended by the specialist due to the lack of heritage resources within the area. The requirement for the development and implementation of a chance find procedure in the event of a heritage find has been included.

2.4.5 Visual Impacts

The Visual Impact Assessment (**Appendix H** of the EIA Report) identified negative impacts on visual receptors during the undertaking of construction activities and the operation phase of Lichtenburg 2.

During the construction phase the undertaking of construction activities will impact on sensitive visual receptors in close proximity to Lichtenburg 2. The construction phase will result in a noticeable increase in heavy vehicles utilising the roads which may cause a visual nuisance to other road users and landowners in the area. The construction phase visual impacts will have a low significance following the implementation of the recommended mitigation measures.

Visual impacts expected to occur during the operation phase includes impact on sensitive visual receptors in close proximity (i.e. within 3km) to the facility, visual impact on sensitive visual receptors within the broader region (i.e. within 3-6km), lighting impacts, solar glint and glare impacts, visual impact of the ancillary infrastructure, the visual impact on sensitive visual receptors located within a 500m radius of the associated power line infrastructure, and a visual impact of Lichtenburg 2 on the sense of place in the region. The significance of the visual impacts range from low to moderate with the implementation of the recommended mitigation measures. Visual impacts on sensitive visual receptors in close proximity to the PV facility are not considered to be a fatal flaw for the development. No mitigation is possible for the visual impact on sensitive visual receptors within 500m of the power line infrastructure, therefore only best practise measures can be implemented and have been recommended by the specialist. The specialist has indicated support for the development of Lichtenburg 2 from a visual perspective.

2.4.6 Social Impacts

The specialist study identified vulnerable communities within the broader area that may be affected by the development of Lichtenburg 2 and its associated infrastructure. Traditionally, the construction phase of a PV solar development is associated with the majority of social impacts. Many of the social impacts are unavoidable and will take place to some extent, but can be managed through the careful planning and implementation of appropriate mitigation measures. A number of potential positive and negative social impacts have been identified for the project, however an assessment of the potential social impacts indicated that there are no perceived negative impacts that are sufficiently significant to allow them to be classified as fatal flaws.

The Social Impact Assessment (**Appendix I** of the EIA Report) identified positive and negative impacts that are expected to occur during the construction and operation phases of Lichtenburg 2. The assessment identified that the expected benefits associated with the project, which include generation of electricity from renewable sources and local economic and social development, outweigh the perceived impacts associated with the project.

During the construction phase, the positive impacts expected to occur include direct and indirect employment opportunities and skills development and economic multiplier effects. The significance of these impacts are medium with the implementation of the recommended enhancement measures. The negative social impacts expected to occur during the construction phase include an influx of jobseekers and change in population, safety and security impacts, impacts on daily living and moving patterns, nuisance impacts (i.e. noise and dust) and visual impacts. The significance of the negative construction phase impacts will be low to medium with the implementation of the recommended mitigation measures

During the operation phase the positive impacts expected to occur include direct and indirect employment opportunities and skills development, development of non-polluting, renewable energy infrastructure, and a contribution to Local Economic Development (LED) and social upliftment. The significance of the positive operation impacts will be medium to high with the implementation of the recommended enhancement measures. The negative impacts expected during the operation phase include a visual and sense of place impact and impacts associated with the loss of agricultural land. The significance of the negative operation impacts will be low to medium with the implementation of the recommended mitigation measures.

2.4.7 Impacts on Traffic

The Traffic Impact Assessment Report (**Appendix J** of the EIA Report) considered the impacts that the development of Lichtenburg 2 will have on the road network within the surrounding area.

During the construction phase imported elements associated with the development of Lichtenburg 2 will be shipped to and transported from the nearest and most practical port. It is estimated that the total number of heavy vehicle trips would vary between 4500 and 6000 during the construction phase. The calculated number of daily trips would be between 15 and 25. The impact of this on the road network would be negligible, as the additional peak hourly traffic would at most be 2 trips. The low construction and post construction traffic would have no significant impact on the existing traffic levels.

During the operation phase the total number of trips to be generated by the permanent workforce during the AM and PM peak period is 18 vehicles per hour. No other trips are expected to be generated during the operation phase and therefore the additional traffic is not considered to have a significant effect on the internal roads or the access roads and surrounding areas. The significance of the traffic impacts during the operation phase will be low with the implementation of the recommended mitigation measures.

2.5 Environmental Sensitivity

From the specialist investigations undertaken for Lichtenburg 2, the following sensitive areas/environmental features have been identified and demarcated within the project site and avoided by the development footprint (where necessary):

- » **Ecology** – The entire Lichtenburg 2 project site has been identified as being of a medium ecological sensitivity based on the presence of Savanna Grassland throughout the majority of the project site and power line corridor alternatives. Other areas of medium sensitivity are also present throughout the project site and the power line corridor alternatives which relates to the presence of Palaeo-Drainage Grassland. All three on-site substation alternatives are located within the Savanna Grassland. The only area considered to be sensitive from an ecological perspective is a cluster of *Vachelia (Acacia) erioloba* trees located along the northern boundary of the project site. This cluster is avoided by the proposed PV facility.
- » **Bird Habitat and Sensitive Areas** – Areas of moderately high avifauna sensitivity are located within the eastern and western sections of the project site, which relates to the presence of Open Dolomite Grassland or Bush Clump Mosaics. These represent habitat or areas where a high number of bird species were recorded, but also include direct observations of collision-prone bird species. These areas also form part of the home ranges of the Northern Black Korhaan (*Afrotis afraoides*). Other features present within the project site considered to be of a moderately high avifauna sensitivity include artificial watering points located in the eastern portion of the project site. These watering points attract large numbers of granivore passerine and non-passerine bird species due to the availability of water. Development within the moderately high avifauna sensitivity areas is permissible, and these areas are not considered to be restricted in terms of the placement of infrastructure associated with Lichtenburg 2. Areas of moderately high sensitivity are also located within the power line corridor alternatives. Areas of medium avifauna sensitivity are areas related to the presence of Open Dolomite Grasslands or Bush Clump Mosaics, power line servitudes and wet grasslands. These habitat types provide suitable foraging habitat for certain threatened and near threatened bird species, including large terrestrial bird species (e.g. Northern Black

Korhaan) with the potential to interact (e.g. collide) with the proposed electrical infrastructure. However, reporting rates at the site for threatened and near threatened bird species was relatively low, thereby suggesting a medium sensitivity within these areas, even though the majority of the habitat is natural.

- » **Heritage:** Palaeontological observations were made within the project site; however these are not considered to carry any heritage value and are therefore not considered to be sensitive to the development of Lichtenburg 2. These palaeontological observations include piles of rock, rock fragments (with some possibly stromatolitic) and loose boulders with no fossils present. No archaeological features were identified.

A comparative assessment of the layout and design alternatives was undertaken from an environmental perspective and all alternatives were assessed at the same level by all specialists. The preferred alternatives from an environmental perspective have been nominated and included in **Figure 2.2** below; this is also the final preferred layout map of the preferred development footprint for Lichtenburg 2. An environmental sensitivity map overlain with the preferred layout map is included as **Figure 2.3**.

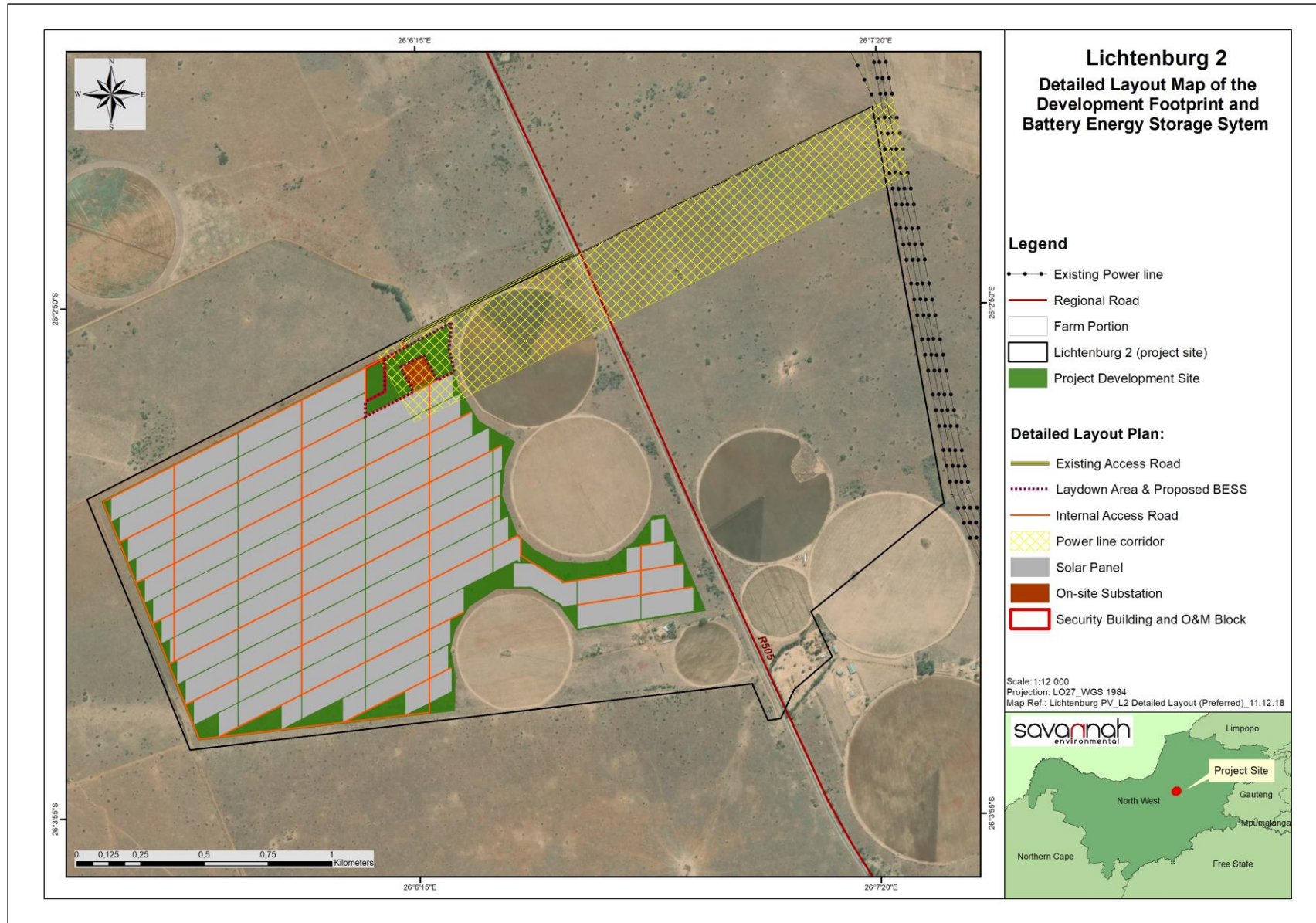

Figure 2.2: Updated preferred layout map of the preferred development footprint for Lichtenburg 2

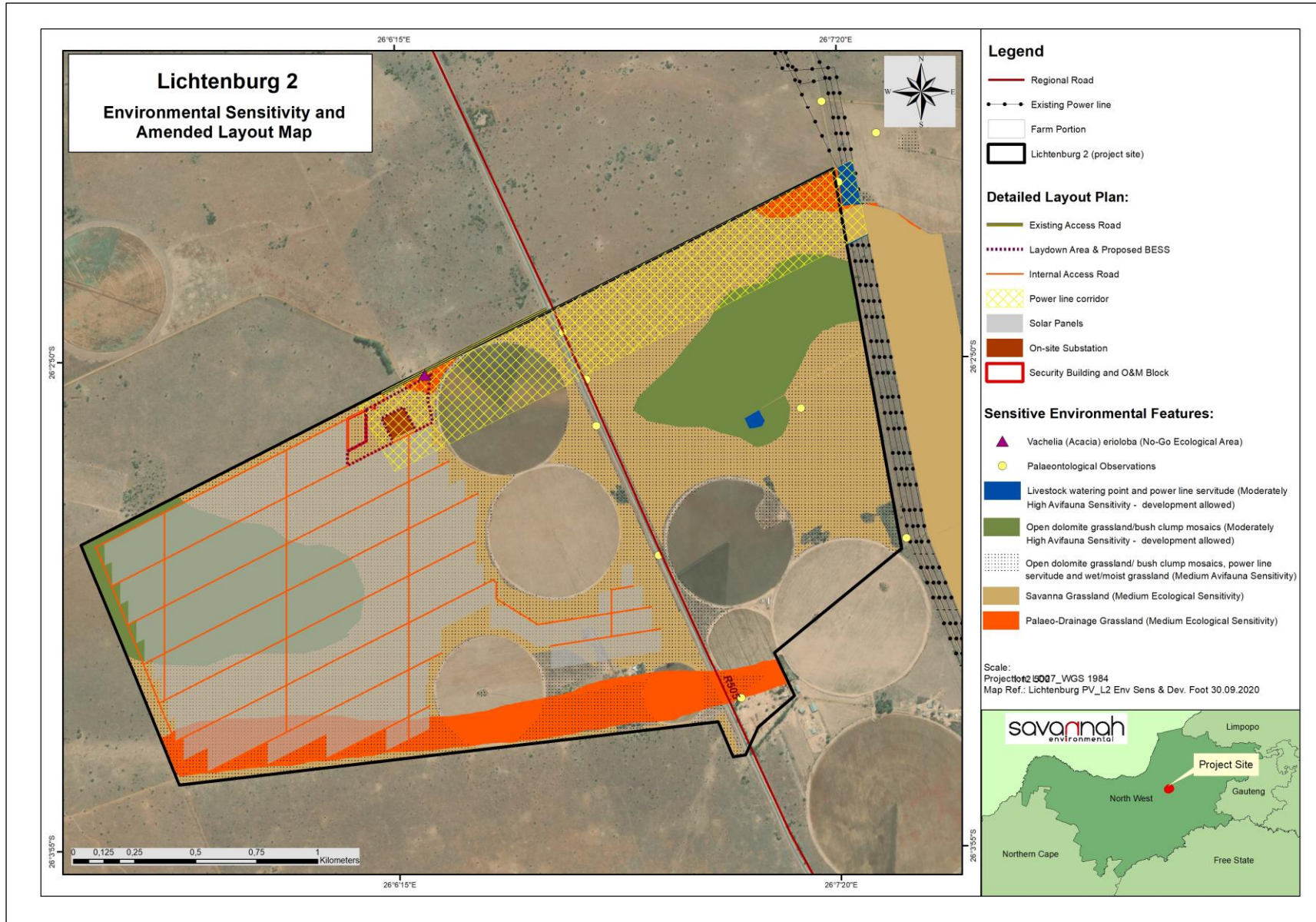

Figure 2.3: Updated preferred layout map of the preferred development footprint for Lichtenburg 2 overlain with the environmental sensitivities

2.6 Contents of this Environmental Management Programme (EMPr)

This Environmental Management Programme (EMPr) has been prepared as part of the EIA process being conducted in support of the application for Environmental Authorisation (EA) for Lichtenburg 2. This EMPr has been prepared in accordance with DEFF's requirements as contained in the Acceptance of Scoping received on 09 November 2018, and Appendix 4 of the 2014 EIA Regulations (GNR 326). It provides recommended management and mitigation measures with which to minimise impacts and enhance benefits associated with the project.

An overview of the contents of this EMPr, as prescribed by Appendix 4 of the 2014 EIA Regulations (GNR 326), and where the corresponding information can be found within this EMPr is provided in **Table 2.3**.

Table 2.3: Summary of where the requirements of Appendix 4 of the 2014 NEMA EIA Regulations (GNR 326) are provided in this EMPr.

Requirement	Location in this EMPr
(1) An EMPr must comply with section 24N of the Act and include –	
(a) Details of –	Chapter 2 Appendix J
(i) The EAP who prepared the EMPr.	
(ii) The expertise of that EAP to prepare an EMPr, including a curriculum vitae.	
(b) A detailed description of the aspects of the activity that are covered by the EMPr as identified by the project description.	Chapter 2
(c) A map at an appropriate scale which superimposes the proposed activity, its associated structures, and infrastructure on the environmental sensitivities of the preferred site, indicating any areas that should be avoided, including buffers.	Chapter 2 Figure 2.3 Appendix A
(d) A description of the impact management outcomes, including management statements, identifying the impacts and risks that need to be avoided, managed and mitigated as identified through the environmental impact assessment process for all phases of the development including –	
(i) Planning and design.	Chapter 5
(ii) Pre-construction activities.	Chapter 5
(iii) Construction activities.	Chapter 6
(iv) Rehabilitation of the environment after construction and where applicable post closure.	Chapter 7
(v) Where relevant, operation activities.	Chapter 8
(f) A description of proposed impact management actions, identifying the manner in which the impact management outcomes contemplated in paragraph (d) will be achieved, and must, where applicable, include actions to –	
(i) Avoid, modify, remedy, control or stop any action, activity or process which causes pollution or environmental degradation.	
(ii) Comply with any prescribed environmental management standards or practices.	Chapters 5 - 8
(iii) Comply with any applicable provisions of the Act regarding closure, where applicable.	
(iv) Comply with any provisions of the Act regarding financial provision for rehabilitation, where applicable.	
(g) The method of monitoring the implementation of the impact management actions contemplated in paragraph (f).	Chapters 5 - 8

Requirement	Location in this EMPr
(h) The frequency of monitoring the implementation of the impact management actions contemplated in paragraph (f).	Chapters 5 - 8
(i) An indication of the persons who will be responsible for the implementation of the impact management actions.	Chapters 5 - 8
(j) The time periods within which the impact management actions contemplated in paragraph (f) must be implemented.	Chapters 5 - 8
(k) The mechanism for monitoring compliance with the impact management actions contemplated in paragraph (f).	Chapters 5 - 8
(l) A program for reporting on compliance, taking into account the requirements as prescribed by the Regulations.	Chapters 6
(m) An environmental awareness plan describing the manner in which – (i) The applicant intends to inform his or her employees of any environmental risk which may result from their work. (ii) Risks must be dealt with in order to avoid pollution or the degradation of the environment.	Chapter 6
(n) Any specific information that may be required by the competent authority.	Table 2.4
(2) Where a government notice gazetted by the Minister provides for a generic EMPr, such generic EMPr as indicated in such notice will apply.	N/A

An overview of the contents of this EMPr, as prescribed by DEFF's Acceptance of Scoping received on 09 November 2018, and where the corresponding information can be found within this EMPr is provided in **Table 2.4**.

Table 2.4: Summary of where the requirements prescribed by DEFF's Acceptance of Scoping are provided in the EMPr.

DEFF requirement for EIA	Response / Location in this EMPr
The Environmental Management Programme (EMPr) to be submitted as part of the EIAR must include the following:	
i. All recommendations and mitigation measures recorded in the EIAR and the specialist studies conducted.	Chapters 5 - 8
ii. The final site layout map.	Chapter 2 Figure 2.2
iii. Measures as dictated by the final site layout map and micro-siting.	Chapters 5 - 8
iv. An environmental sensitivity map indicating environmental sensitive areas and features identified during the EIA process.	Chapter 2 Figure 2.3
v. A map combining the final layout map superimposed (overlain) on the environmental sensitivity map.	Chapter 2 Figure 2.3
vi. An alien invasive management plan to be implemented during construction and operation of the facility. The plan must include mitigation measures to reduce the invasion of alien species and ensure that the continuous monitoring and removal of alien species is undertaken.	Chapter 6 Objective 13
vii. A plant rescue and protection plan which allows for the maximum transplant of conservation important species from areas to be transformed. This plan must be compiled by a vegetation specialist familiar with the site and be implemented prior to commencement of the construction phase.	Appendix E

DEFF requirement for EIA	Response / Location in this EMPr
viii. A re-vegetation and habitat rehabilitation plan to be implemented during the construction and operation of the facility. Restoration must be undertaken as soon as possible after completion of construction activities to reduce the amount of habitat converted at any one time and to speed up the recovery to natural habitats.	Appendix D
ix. An open space management plan to be implemented during the construction and operation of the facility.	Appendix C
x. A traffic management plan for the site access roads to ensure that no hazards would result from the increased truck traffic and that traffic flow would not be adversely impacted. This plan must include measures to minimize impacts on local commuters e.g. limiting construction vehicles travelling on public roadways during the morning and late afternoon commute time and avoid using roads through densely populated built-up areas so as not to disturb existing retail and commercial operations.	Appendix F
xi. A storm water management plan to be implemented during the construction and operation of the facility. The plan must ensure compliance with applicable regulations and prevent off-site migration of contaminated storm water or increased soil erosion. The plan must include the construction of appropriate design measures that allow surface and subsurface movement of water along drainage lines so as not to impede natural surface and subsurface flows. Drainage measures must promote the dissipation of storm water run-off.	Appendix G
xii. A fire management plan to be implemented during the construction and operation of the facility.	Appendix I
xiii. An erosion management plan for monitoring and rehabilitating erosion events associated with the facility. Appropriate erosion mitigation must form part of this plan to prevent and reduce the risk of any potential erosion.	Appendix G
xiv. An effective monitoring system to detect any leakage or spillage of all hazardous substances during their transportation, handling, use and storage. This must include precautionary measures to limit the possibility of oil and other toxic liquids from entering the soil or storm water systems.	Effective mitigation measures for the handling and storage of hazardous substances are included in Chapter 6 Objective 20 and Chapter 8 Objective 8
xv. Measures to protect hydrological features such as streams, rivers, pans, wetlands, dams and their catchments, and other environmental sensitive areas from construction impacts including the direct or indirect spillage of pollutants.	No hydrological features are present within the Lichtenburg 2 project site and as such no measures for the protection of hydrological features have been included in the EMPr. Measures to protect other environmental sensitive areas have been identified and are included in Chapters 5 - 8

2.7 Project Team

In accordance with Regulation 12 of the 2014 EIA Regulations (GNR 326) the applicant appointed Savannah Environmental (Pty) Ltd as the independent environmental consultants responsible for managing the application for EA and the supporting Scoping and EIA process. The application for EA, and Scoping and

EIA process, is being managed in accordance with the requirements of NEMA, the 2014 EIA Regulations (GNR 326), and all other relevant applicable legislation.

2.7.1 Details and Expertise of the Environmental Assessment Practitioner (EAP)

Savannah Environmental is a leading provider of integrated environmental and social consulting, advisory and management services with considerable experience in the fields of environmental assessment and management. The company is wholly woman-owned (51% black woman-owned), and is rated as a Level 2 Broad-based Black Economic Empowerment (B-BBEE) Contributor. Savannah Environmental's team have been actively involved in undertaking environmental studies over the past 12 years, for a wide variety of projects throughout South Africa, including those associated with electricity generation and infrastructure development.

Jo-Anne Thomas and Lisa Opperman are the EAPs responsible for preparing this EMPr. An overview of their expertise to prepare the EMPr is provided below, and copies of their Curricula Vitae (CVs) detailing the Savannah Environmental team's expertise and relevant experience are provided in **Appendix J** to this EMPr.

- » **Jo-Anne Thomas** is a Director at Savannah Environmental (Pty) Ltd and the registered EAP for the EIA for this project. Jo-Anne holds a Master of Science Degree in Botany (M.Sc. Botany) from the University of the Witwatersrand, and is registered as a Professional Natural Scientist (400024/2000) with the South African Council for Natural Scientific Professions (SACNASP). She has over 20 years of experience in the field of environmental assessment and management, and the management of large environmental assessment and management projects. During this time she has managed and coordinated a multitude of large-scale infrastructure EIAs, and is also well versed in the management and leadership of teams of specialist consultants, and dynamic stakeholders. Jo-Anne has been responsible for providing technical input for projects in the environmental management field, specialising in Strategic Environmental Advice, EIA studies, environmental permitting, public participation, EMPs and EMPs, environmental policy, strategy and guideline formulation, and integrated environmental management (IEM). Her responsibilities for environmental studies include project management, review and integration of specialist studies, identification and assessment of potential negative environmental impacts and benefits, and the identification of mitigation measures, and compilation of reports in accordance with applicable environmental legislation.
- » **Lisa Opperman** is an Environmental and GIS Consultant at Savannah Environmental. Lisa has a Bachelor of Science Honours Degree in Environmental Management (B.Sc. Honours) and 3 years of experience in the environmental field. Her key focus is on environmental impact assessments, public participation, environmental management plans and programmes, as well as mapping using ArcGIS for a variety of environmental projects. She is currently involved in several EIAs for energy generation projects across South Africa.

Savannah Environmental's team have been actively involved in undertaking environmental studies over the past 12 years, for a wide variety of projects throughout South Africa, including those associated with electricity generation and infrastructure development, and therefore have extensive knowledge and experience in EIAs and environmental management, having managed and drafted EMPs for numerous other power generation projects throughout South Africa.

2.7.2 Details of the Specialist Consultants

A team of specialist consultants have been appointed as part of the EIA project team in order to adequately identify and assess potential impacts associated with the project, and have also provided input into this EMPr (refer to **Table 2.5**).

Table 2.5: Specialist Consultants which provided input into this EMPr.

Specialist Study	Specialist Company	Specialist Name
Ecology and Wetlands	Nkurenkuru Ecology & Biodiversity	Gerhard Botha
Avifauna	Pachnoda Consulting	Lukas Niemand
Soils, Land Use, Land Capability and Agricultural Potential	Terra Africa Environmental Consultants	Mariné Pienaar
Heritage (Archaeology and Palaeontology)	CTS Heritage	Jenna Lavin
Visual	LOGIS	Lourens du Plessis
Social	Savannah Environmental	Sarah Watson
Social (External peer review)	Dr. Neville Bews and Associates	Dr. Neville Bews
Traffic	Knight Piésold	Amory Le Roux-Arries

CHAPTER 3 : PURPOSE AND OBJECTIVES OF THE EMPr

An Environmental Management Programme (EMPr) is defined as “an environmental management tool used to ensure that undue or reasonably avoidable adverse impacts of the construction, operation and decommissioning of a project are prevented or mitigated, and that the positive benefits of the projects are enhanced”. The objective of this EMPr is to provide consistent information and guidance for implementing the management and monitoring measures established in the permitting process and help achieve environmental policy goals. The purpose of an EMPr is to help ensure continuous improvement of environmental performance, reducing negative impacts and enhancing positive effects during the construction and operation of the facility. An effective EMPr is concerned with both the immediate outcome as well as the long-term impacts of the project.

The EMPr provides specific environmental guidance for the construction and operation phases of a project, and is intended to manage and mitigate construction and operation activities so that unnecessary or preventable environmental impacts do not result. These impacts range from those incurred during start up (site clearing and site establishment) through to those incurred during the construction activities themselves (erosion, noise, dust) to those incurred during site rehabilitation (soil stabilisation, re-vegetation) and operation. The EMPr also defines monitoring requirements in order to ensure that the specified objectives are met.

This EMPr is applicable to all employees and contractors working on the pre-construction, construction, and operation and maintenance phases of Lichtenburg 2. The document will be adhered to and updated as relevant throughout the project life cycle.

This EMPr has been compiled in accordance with Appendix 4 of the EIA Regulations, 2014 (as amended) (refer to **Table 2.3**). This is a dynamic document and will be further developed in terms of specific requirements listed in any authorisations issued for Lichtenburg 2 and/or as the project develops. The EMPr has been developed as a set of environmental specifications (i.e. principles of environmental management), which are appropriately contextualised to provide clear guidance in terms of the on-site implementation of these specifications (i.e. on-site contextualisation is provided through the inclusion of various monitoring and implementation tools).

The EMPr has the following objectives:

- » Outline mitigation measures and environmental specifications which are required to be implemented for the planning, construction, rehabilitation and operation phases of the project in order to minimise the extent of environmental impacts, and to manage environmental impacts associated with Lichtenburg 2.
- » Ensure that the construction and operation phases do not result in undue or reasonably avoidable adverse environmental impacts, and ensure that any potential environmental benefits are enhanced.
- » Identify entities who will be responsible for the implementation of the measures and outline functions and responsibilities.
- » Propose mechanisms and frequency for monitoring compliance, and prevent long-term or permanent environmental degradation.
- » Facilitate appropriate and proactive responses to unforeseen events or changes in project implementation that were not considered in the EIA process.

The mitigation measures identified within the EIA process are systematically addressed in the EMPr, ensuring the minimisation of adverse environmental impacts to an acceptable level.

ABO Wind Lichtenburg 2 PV (Pty) Ltd must ensure that the implementation of the project complies with the requirements of all environmental authorisations, permits, and obligations emanating from relevant environmental legislation. This obligation is partly met through the development and the implementation of this EMPr, and through its integration into the relevant contract documentation provided to parties responsible for construction and/or operation activities on the site. The adequacy and efficacy of implementation is to be monitored by an independent Environmental Control Officer (ECO). Since this EMPr is part of the EIA process for Lichtenburg 2, it is important that this document be read in conjunction with the EIA Report compiled for this project. This will contextualise the EMPr and enable a thorough understanding of its role and purpose in the integrated environmental management process. Should there be a conflict of interpretation between this EMPr and the Environmental Authorisation, the stipulations in the Environmental Authorisation shall prevail over that of the EMPr, unless otherwise agreed by the authorities in writing. Similarly, any provisions in legislation overrule any provisions or interpretations within this EMPr.

This EMPr shall be binding on all the parties involved in the planning, construction and operational phases of the project, and shall be enforceable at all levels of contract and operational management within the project. The document must be adhered to and updated as relevant throughout the project life cycle.

CHAPTER 4: STRUCTURE OF THIS EMPR

The preceding chapters provide background to the EMPr and the proposed project, while the chapters which follow consider the following:

- » Planning and design activities;
- » Construction activities;
- » Operation activities; and
- » Decommissioning activities.

These chapters set out the procedures necessary for the project owner to minimise environmental impacts and achieve environmental compliance. For each of the phases of implementation for the PV facility project, an over-arching environmental **goal** is stated. In order to meet this goal, a number of **objectives** are listed. The management programme has been structured in table format in order to show the links between the goals for each phase and their associated objectives, activities/risk sources, mitigation actions, monitoring requirements and performance indicators. A specific EMPr table has been established for each environmental objective. The information provided within the EMPr table for each objective is illustrated below:

OBJECTIVE: Description of the objective, which is necessary to meet the overall goals; which take into account the findings of the EIA specialist studies

Project Component/s	List of project components affecting the objective, i.e.: <ul style="list-style-type: none"> » PV Panels » <u>BESS</u> » Access roads; and » Associated infrastructure.
Potential Impact	Brief description of potential environmental impact if objective is not met.
Activity/Risk Source	Description of activities which could affect achieving the objective.
Mitigation: Target/Objective	Description of the target and/or desired outcomes of mitigation.

Mitigation: Action/Control	Responsibility	Timeframe
List specific action(s) required to meet the mitigation target/objective described above.	Who is responsible for the measures	Time periods for implementation of measures

Performance Indicator	Description of key indicator(s) that track progress/indicate the effectiveness of the management programme.
Monitoring	Mechanisms for monitoring compliance; the key monitoring actions required to check whether the objectives are being achieved, taking into consideration responsibility, frequency, methods, and reporting.

The objectives and EMPr tables are required to be reviewed and possibly modified whenever changes, such as the following, occur:

- » Planned activities change (i.e. in terms of the components and/or layout of the facility);
- » Modification to or addition to environmental objectives and targets;
- » Additional or unforeseen environmental impacts are identified and additional measures are required to be included in the EMPr to prevent deterioration or further deterioration of the environment.
- » Relevant legal or other requirements are changed or introduced; and
- » Significant progress has been made on achieving an objective or target such that it should be re-examined to determine if it is still relevant, should be modified, etc.

CHAPTER 5: PLANNING AND DESIGN MANAGEMENT PROGRAMME

Overall Goal: undertake the pre-construction activities (planning and design phase) in a way that:

- » Ensures that the preferred design and layout of the PV panels, on-site substation, BESS and associated infrastructure responds to the identified environmental constraints and opportunities.
- » Ensures that pre-construction activities are undertaken in accordance with all relevant legislative requirements.
- » Ensures that adequate regard has been taken of any landowner and community concerns and that these are appropriately addressed through design and planning (where appropriate).
- » Ensures that the best environmental options are selected for the linear components (underground cable network, short distribution powerline), including the access roads.
- » Enables the construction activities to be undertaken without significant disruption to other land uses and activities in the area.

In order to meet this goal, the following objectives have been identified, together with necessary actions and monitoring requirements.

5.1 Objectives

OBJECTIVE 1: Ensure the facility design responds to identified environmental constraints and opportunities

Only one no-go area has been identified within the project site. This area is considered to be sensitive from an ecological perspective due to the presence of a cluster of *Vachelia (Acacia) erioloba* trees located along the northern boundary of the project site. This cluster is avoided by the proposed PV facility. Negative impacts on this tree cluster will be avoided if all construction activities are strictly confined to the development footprint with no uncontrolled movement outside of this area (coordinates of *Vachelia (Acacia) erioloba*: -26.047774°; 26.105356°).

Project Component/s	<ul style="list-style-type: none"> » PV Panels » <u>BESS</u> » Access roads » Power line » On-site substation » Inverter stations » Transformer » Underground cabling » Associated buildings (i.e. workshop, ablution facilities, control room, storage).
Potential Impact	<ul style="list-style-type: none"> » Impact on identified sensitive areas. » Negative visual impact associated with the planning of the PV facility. » Increased risk of veld fire and damage to property as a result.
Activities/Risk Sources	<ul style="list-style-type: none"> » Positioning of all the facilities components and the viewing of the project components by observers » Construction of the underground cabling

	<ul style="list-style-type: none"> » Connection to the on-site substation » Access road construction
Mitigation: Target/Objective	<ul style="list-style-type: none"> » The design of the power line and on-site substation responds to the identified environmental constraints and opportunities. » Optimal planning of infrastructure to minimise visual impact. » Site sensitivities are taken into consideration and avoided as far as possible, thereby mitigating potential impacts.

Mitigation: Action/Control	Responsibility	Timeframe
Plan and conduct pre-construction activities in an environmentally acceptable manner.	Developer Contractor	Pre-construction
Undertake a detailed geotechnical pre-construction survey.	Developer Geotechnical specialist	Pre-construction
Plan the placement of lay-down areas and temporary construction equipment camps in order to minimise vegetation clearing (i.e. in already disturbed areas) wherever possible.	Developer	Pre-construction
An ecological pre-construction walk-through of the final development footprint <u>(including the footprint of the BESS)</u> for species of conservation concern that would be affected and that can be translocated must be undertaken prior to the commencement of the construction phase.	Developer Specialist	Pre-construction
Before construction commences individuals of listed species (specifically geophytes and succulents) within the development footprint that would be affected, must be counted and marked and translocated, where deemed necessary by the ecologist conducting the pre-construction walk-through survey, and according to the recommended rations (as specified within the pre-construction walk-through report). Permits from the relevant provincial authorities, i.e. the North-West Department of Rural, Environment and Agricultural Development, must be obtained before the individuals are disturbed.	Developer Specialist	Pre-construction
At least one additional avifauna pre-construction survey is recommended, each consisting of a minimum of 1-2 days which is necessary to inform the operation management plan. The survey should coincide with the peak wet season when most of the drainage lines and wetland features in the wider study region are inundated. This will enable the observer to obtain quantified data on waterbird richness and potential flyways, which will contribute towards the understanding of impacts related to collision trauma with the panels.	Avifauna specialist	Pre-construction
The Endangered Wildlife Trust (EWT) must be consulted to identify an appropriate pylon design for the associated power line. The pylon design must incorporate the following design parameters: <ul style="list-style-type: none"> » The clearances between the live components must be as wide as possible within the design limitations / capabilities of the power line. » The height of the tower must allow for unrestricted movement of terrestrial birds between successive pylons. 	Developer	Pre-construction

Mitigation: Action/Control	Responsibility	Timeframe
<ul style="list-style-type: none"> » The live components must be “bundled” to increase the visibility for approaching birds. » “Bird streamers” must be eliminated by discouraging birds from perching above the conductors. In addition, conductors must be strung below the pole to avoid bridging the air gap by perching birds of prey. 		
<u>The electrochemical battery energy storage system should be contained or covered (to prevent access to the batteries).</u>	<u>Developer</u>	<u>Project Planning</u>
<u>Any above-ground cables connecting to the BESS with the on-site facility substation should be covered with insulating material to prevent the risk of potential electrocutions should any large bird species interact in any manner with the BESS.</u>	<u>Developer</u>	<u>Project Planning</u>
Obtain any additional environmental permits required (e.g. water use license, and protected plant permits, etc.). Copies of permits/licenses must be submitted to the Director: Environmental Impact Evaluation at the <u>DEFF</u> .	Developer	Project planning
A suitably qualified Invasive Alien Plant expert must map and quantify the Invasive Alien Plant (IAP) and weeds on the site. This must be undertaken with the aim of developing a suitable IAP and Weed Management plan as per <u>DEFF</u> and NEMBA requirements.	Developer Specialist	Pre-construction
An IAP consultant with registered Pest Control Operator (PCO) in the field of Noxious weed management must develop a management plan for the site. The IAP management plan needs to address the legality, according to NEMBA, of moving plant propagules across the site	Developer Specialist	Pre-construction
Retain and maintain natural and / or cultivated vegetation immediately adjacent to the development footprint/servitude. Plan all roads, ancillary buildings and ancillary infrastructure in such a way that clearing of vegetation is minimised. Consolidate infrastructure and make use of already disturbed sites rather than undisturbed areas.	Developer	Project planning
A designated access to the site must be created and clearly marked to ensure safe entry and exit.	Developer Contractor	Design
Internal access roads must be carefully planned to maximise road user safety and limit any intrusion on the neighbouring property owners and road users.	Developer Contractor	Design
Roads must be designed so that changes to surface water runoff are avoided and erosion is not initiated.	Developer Contractor	Design
Make use of existing roads wherever possible and plan the layout and construction of roads and infrastructure with due cognisance of the topography to limit cut and fill requirements.	Developer Contractor	Design
The road network to access the panel arrays should be established first and then all vehicular movement must be restricted to within this road network. This will minimise the impact of construction traffic.	Developer Contractor	Design and Planning
Construction vehicles carrying materials to the site must avoid using roads through densely populated built-up areas so as to not disturb existing retail and commercial operations.	Developer Contractor	Design and Planning

Mitigation: Action/Control	Responsibility	Timeframe
Contractors and construction workers must be clearly informed of the no-go areas.	Developer Contractor	Prior to the commencement of construction
Demarcation of no-go areas must reflect the exact footprint of the construction area, including panel foundations and all roads and infrastructure which are to be surveyed and pegged before any physical construction commences on site.	Developer Contractor	Prior to the commencement of construction
Compile a comprehensive stormwater management plan for hard surfaces as part of the final design of the project. This must include appropriate means for the handling of stormwater within the site, as well as appropriate drainage around the site (Appendix G) .	Developer Contractor	Design
Plan and placement of light fixtures for the plant and the ancillary infrastructure in such a manner so as to minimise glare and impacts on the surrounding area.	Developer Contractor	Planning.
Reduce the construction period as far as possible through careful planning and productive implementation of resources.	Developer Contractor	Pre-construction
Plan the placement of laydown areas and construction equipment camps in order to minimise vegetation clearing and impacts on identified sensitive areas.	Developer	Pre-construction
No temporary site camps must be allowed outside the development footprint of the project.	Developer	Design and planning
An experienced independent Environmental Control Officer (ECO) must be appointed for the construction phase. The Environmental Officer (EO) will have the responsibility to ensure that the mitigation/rehabilitation measures and recommendations included in the Environmental Authorisation are implemented to ensure compliance.	Developer	Pre-construction
The terms of this EMPr and the Environmental Authorisation must be included in all tender documentation and Contractors contracts.	Developer Contractor	Pre-construction
<u>All layout components of Lichtenburg 2 must be finalised and the final layout must be submitted to DEFF for approval prior to the commencement of the construction phase.</u>	<u>Developer</u>	<u>Pre-construction</u>
All areas to be cleared should be clearly demarcated. Sensitive areas as demarcated on the sensitivity map should be avoided, and where such areas occur within or near the development area, they should be clearly demarcated as no-go areas. Only those individuals of protected plant species directly within the development footprint should be cleared.	Developer	Design review phase
Areas outside of the footprint, including sensitive areas, must be clearly demarcated (using fencing and appropriate signage) before construction commences and must be regarded as no-go areas.	Developer Contractor	Pre-construction
Underground cables and internal access roads must be aligned as much as possible along existing infrastructure to limit damage to vegetation.	Developer Contractor	Design Pre-construction

Mitigation: Action/Control	Responsibility	Timeframe
<p>Consult a lighting engineer in the design and planning of lighting to ensure the correct specification and placement of lighting and light fixtures for the PV facility and the ancillary infrastructure. The following is recommended:</p> <ul style="list-style-type: none"> » Shield the sources of light by physical barriers (walls, vegetation, or the structure itself). » Limit mounting heights of fixtures, or use foot-lights or bollard lights. » Make use of minimum lumen or wattage in fixtures. » Making use of down-lighters or shielded fixtures. » Make use of Low Pressure Sodium lighting or other low impact lighting. » Make use of motion detectors on security lighting, so allowing the site to remain in darkness until lighting is required for security or maintenance purposes. 	<p>Developer Contractor</p>	<p>Design Pre-construction</p>
<p>Training and skills development programmes to be initiated prior to the commencement of the construction phase.</p>	<p>Developer Contractor</p>	<p>Pre-construction</p>
<p>A local procurement policy must be adopted to maximise the benefit to the local economy.</p>	<p>Developer</p>	<p>Pre-construction</p>
<p>Develop a database of local companies, specifically Historically Disadvantaged (HD) which qualify as potential service providers (e.g. construction companies, security companies, catering companies, waste collection companies, transportation companies etc.) prior to the tender process and invite them to bid for project-related work where applicable.</p>	<p>Developer</p>	<p>Pre-construction</p>
<p>Where applicable, any tender documentation which may be prepared for the project is to stipulate the use of local labour as far as possible.</p>	<p>Developer Contractor</p>	<p>Pre-Construction</p>
<p>Inform local community members of the construction schedule and exact size of workforce (e.g. Ward Councillor, surrounding landowners).</p>	<p>Developer Contractor</p>	<p>Pre-Construction</p>
<p>Recruitment of temporary workers onsite is not to be permitted. A recruitment office with a Community Liaison Officer should be established to deal with jobseekers.</p>	<p>Developer Contractor</p>	<p>Pre-Construction</p>
<p>Set up a labour desk in a secure and suitable area to discourage the gathering of people at the construction site.</p>	<p>Developer Contractor</p>	<p>Pre-Construction</p>
<p>Have clear rules and regulations for access to the proposed site.</p>	<p>Developer Contractor</p>	<p>Pre-Construction</p>
<p>Local community organisations and policing forums must be informed of construction times and the duration of the construction phase. Also procedures for the control and removal of loiters at the construction site should be established.</p>	<p>Developer Contractor</p>	<p>Pre-Construction</p>
<p>Security company to be appointed and appropriate security procedures to be implemented.</p>	<p>Developer Contractor</p>	<p>Pre-Construction</p>
<p>Contractor must provide adequate firefighting equipment on site and provide firefighting training to selected construction staff.</p>	<p>Contractor</p>	<p>Pre-construction</p>

Mitigation: Action/Control	Responsibility	Timeframe
A comprehensive employee induction programme must be developed and utilised to cover land access protocols, fire management and road safety.	Contractor	Pre-construction
Have a personnel trained in first aid on site to deal with smaller incidents that require medical attention.	Contractor	Pre-construction
Prepare a Fire Management Plan (FMP) (Appendix I) in collaboration with surrounding landowners.	Developer	Pre-construction
Communicate the FMP to surrounding landowners and maintain records thereof.	Developer	Pre-construction Construction
Prepare a Method Statement pertaining to the clearance of vegetation under solar panels in accordance with the FMP.	Developer Contractor	Pre-construction
All Eskom requirements must be complied with for work in or near Eskom servitudes.	Developer Contractor	Planning and pre-construction
Where sensitive visual receptors are likely to be affected (i.e. residents of homesteads and settlements in close proximity), the developer must enter into negotiations regarding the potential screening of visual impacts at the receptor site. this may entail the planting of vegetation, trees or the construction of screens. Visual screening is most effective when placed at the receptor itself.	Developer Contractor	Planning and pre-construction

Performance Indicator	<ul style="list-style-type: none"> » The design meets the objectives and does not degrade the environment. » Demarcated sensitive areas are avoided at all times. » Design and layouts respond to the mitigation measures and recommendations in the EIA Report. » Minimal exposure of ancillary infrastructure and lighting at night to observers on or near the site (i.e. within 3km) and within the region. » Employment and business policy document that sets out local employment and targets completed before the construction phase commences. » Training and skills development programme undertaken prior to the commencement of construction phase. » Employee induction programme, covering land access protocols, fire management and road safety. » Ensure a security company is appointed and appropriate security procedures and measures are implemented. » A local procurement policy is adopted.
Monitoring	<ul style="list-style-type: none"> » Review of the design by the Project Manager and the Environmental Control Officer (ECO) prior to the commencement of construction. » Monitor ongoing compliance with the FMP and method statements.

OBJECTIVE 2: Ensure the selection of the best environmental option for the alignment of the power line and underground cabling

Underground cables will be laid between the PV panels, the BESS, the transformers and the switchgear. This will require the excavation of trenches within which they can then be laid. A new 88/132kV power line linking

the proposed on-site substation to the national grid via a Loop-in / Loop-out connection to the existing Mmabatho/ Watershed DS 2 88kV power line traversing east of the project site is preferred. The BESS will require 33kV multi-core underground cables, to follow internal access roads, to be connected to the on-site substation in order for a connection to be established between the solar energy facility and the BESS. Existing access roads will be used for the facility where possible.

Only one *Vachelia (Acacia) erioloba* cluster (3 tree specimens) was observed within the project site and could potentially be affected by the power line due to the location of the cluster within the assessed power line corridor. This cluster should be cordoned off during construction (excluded from the development footprint) and any impacts on this cluster should be avoided (Coordinates of *Vachelia (Acacia) erioloba*: -26.047774°S; 26.105356°E).

Project Component/s	<ul style="list-style-type: none"> » Underground cabling. » Power line. » Temporary internal access roads.
Potential Impact	<ul style="list-style-type: none"> » Routes that degrade the environment unnecessarily, particularly with respect to loss of indigenous flora, and erosion. » Impact on the power line on sensitive features.
Activities/Risk Sources	<ul style="list-style-type: none"> » Alignment of underground cabling. » Alignment of power line. » Alignment of new access roads.
Mitigation: Target/Objective	<ul style="list-style-type: none"> » Ensure selection of best environmental option for alignment of the linear infrastructure. » Environmental sensitivities are taken into consideration and avoided as far as possible, thereby mitigating potential impacts.

Mitigation: Action/Control	Responsibility	Timeframe
Select an alignment for the underground cabling, power line and any new access roads that curtails environmental impacts and enhances environmental benefits.	Developer Contractor	Prior to submission of the final construction layout plan
This <i>Vachelia (Acacia) erioloba</i> cluster (3 tree specimens) should be cordoned off during construction (excluded from the development footprint) and any impacts on this cluster should be avoided.	Developer Contractor	Design and construction phase
Consider design level mitigation measures recommended by the specialists as detailed within the EIA Report and relevant appendices regarding the associated infrastructure.	Contractor	Design
<u>Any above-ground cables connecting the BESS with the on-site facility substation should be covered with insulating material to prevent the risk of potential electrocutions should any large bird species interact in any manner with the BESS.</u>	<u>Contractor</u>	<u>Design</u>

Performance Indicator	<ul style="list-style-type: none"> » Underground cabling, power line and new access road alignments meet environmental objectives. » Selected linear alignments that minimise any negative environmental impacts and maximise any benefits.
Monitoring	<ul style="list-style-type: none"> » Ensure that the design implemented meets the objectives and mitigation measures in the EIA Report through review of the design by the Project Manager, and the ECO prior to the commencement of construction.

OBJECTIVE 3: Minimise stormwater runoff

Project Component/s	<ul style="list-style-type: none"> » Stormwater management components. » All hard engineered surfaces (i.e. new access roads).
Potential Impact	<ul style="list-style-type: none"> » Poor stormwater management and alteration of the hydrological regime outside of the project site.
Activities/Risk Sources	<ul style="list-style-type: none"> » Construction of the facility (i.e. placement of hard engineered surfaces).
Mitigation: Target/Objective	<ul style="list-style-type: none"> » Appropriate management of stormwater to minimise impacts on the environment.

Mitigation: Action/Control	Responsibility	Timeframe
Appropriately plan hard-engineered erosion protection structures.	Developer Contractor	Planning and design
Design an appropriate stormwater management plan for implementation during construction and operation (Appendix G). This plan must ensure the suitable handling of stormwater within the site.	Developer Contractor	Planning and design
Construction must include appropriate design measures that allow surface and sub-surface movement of water. Drainage measures must promote the dissipation of stormwater runoff.	Developer Contractor	Planning and design

Performance Indicator	<ul style="list-style-type: none"> » Appropriate stormwater management plan developed for implementation prior to commencement of construction.
Monitoring	<ul style="list-style-type: none"> » Minimal erosion.

OBJECTIVE 4: To ensure effective communication mechanisms

On-going communication with affected and surrounding landowners is important to maintain during the construction and operation phases of the development. Any issues and concerns raised should be addressed as far as possible in as short a timeframe as possible.

Project component/s	<ul style="list-style-type: none"> » PV Panels » <u>BESS</u> » Access roads » Power line » Underground cabling » Laydown area » Associated buildings and associated infrastructure (workshop, storage facility, ablution facility, substation, inverters, transformers etc).
Potential Impact	<ul style="list-style-type: none"> » Impacts on affected and surrounding landowners and land uses
Activity/risk source	<ul style="list-style-type: none"> » Activities associated with the PV facility (<u>including the BESS</u>) construction » Activities associated with the PV facility (<u>including the BESS</u>) operation

Mitigation: Target/Objective	<ul style="list-style-type: none"> » Effective communication with affected and surrounding landowners » Addressing of any issues and concerns raised as far as possible in as short a timeframe as possible
---	---

Mitigation: Action/control	Responsibility	Timeframe
Compile and implement a grievance mechanism procedure for the public (following the guidelines of the grievance mechanism in Appendix B) to be implemented during both the construction and operation phases of the facility. This procedure should include details of the contact person who will be receiving issues raised by interested and affected parties, and the process that will be followed to address issues.	Developer Contractor O&M Contractor	Pre-construction (construction procedure) Pre-operation (operation procedure)
Develop and implement a grievance mechanism for the construction, operation and closure phases of the project for all employees, contractors, subcontractors and site personnel. This procedure should be in line with the South African Labour Law.	Developer Contractor O&M Contractor	Pre-construction (construction procedure) Pre-operation (operation procedure)
Liaison with landowners must be undertaken prior to the commencement of construction in order to provide sufficient time for them to plan agricultural activities.	Developer Contractor	Pre-construction
Before construction commences, representatives from the local municipality, community leaders, community-based organisations and the surrounding property owners (of the larger area), must be informed of the details of the contractors, size of the workforce and construction schedules.	Developer Contractor	Pre-construction and construction

Performance Indicator	» Effective communication procedures in place.
Monitoring	<ul style="list-style-type: none"> » A Public Complaints register must be maintained, by the Contractor and monitored by the ECO, to record all complaints and queries relating to the project and the action taken to resolve the issue. » All correspondence should be in writing. » The developer and contractor must keep a record of local recruitments and information on local labour to be shared with the ECO for reporting purposes.

OBJECTIVE 5: Ensure that all relevant personnel and staff are familiar with the provisions of the EMPr, as well as the conditions of the Environmental Authorisation and requirement for environmental preservation

It is recommended that a pre-construction environmental compliance workshop be undertaken before any construction commences on site. This workshop can be combined with a site handover meeting, but must take place before any activities take place on site and before any equipment is moved onto site. Furthermore, all construction workers should receive an induction presentation, as well as on-going environmental education, awareness and training on the importance and implications of the EMPr and the environmental requirements it prescribes. The presentation must be conducted, as far as is possible, in the employees' language of choice. The contractor should provide a translator from their staff for the purpose of translating should this be necessary.

Project Component/s	<ul style="list-style-type: none"> » All components and activity impacts mentioned in the EMPr » All components and activity impacts mentioned in the EIA Report
Potential Impact	<ul style="list-style-type: none"> » Positive impact on creating project awareness » Skills improvement » Project compliance
Activities/Risk Sources	<ul style="list-style-type: none"> » Compliance workshop » Slide presentations » On-going environmental education and awareness training
Mitigation: Target/Objective	<ul style="list-style-type: none"> » Environmental sensitivities are taken into consideration and avoided as far as possible, thereby mitigating potential impacts.

Mitigation: Action/Control	Responsibility	Timeframe
Provision should be made in contract and tender documentation to attend a workshop.	<ul style="list-style-type: none"> » The Main Civil Contractor (including contract manager, site agent and foreman) » The Electrical Contractor (including contract manager, site agent and foreman) » The Consulting Engineers (electrical, civil and structural, whichever applicable) » Project Management 	Pre-construction
Induction training must ensure that construction workers/staff understand that no form of wildlife poaching, collecting or other form of disturbance will be permitted on the construction site or the adjacent areas.	EO	Pre-construction

Performance Indicator	<ul style="list-style-type: none"> » Staff Performance » Staff adherence » Staff attendance » Staff turn over » Ensure that the design implemented meets the objectives and mitigation measures in the EIA Report » The contractor must keep records of all environmental training sessions, including names, dates and the information presented. Details of the environmental induction must be included in the environmental control reports.
Monitoring	<p>As a minimum, ongoing training should include:</p> <ul style="list-style-type: none"> » Explanation of the importance of complying with the EMPr; » Explanation of the importance of complying with the Environmental Authorisation; » Discussion of the potential environmental impacts of construction activities; » Employees' roles and responsibilities, including emergency preparedness (this should be combined with this induction, but presented by the contractors Health and Safety Representative); » Explanation of the mitigation measures that must be implemented when carrying out activities; and » Explanation of the specifics of this EMPr and its specification (no-go areas, etc.).

CHAPTER 6: MANAGEMENT PROGRAMME: CONSTRUCTION

Overall Goal: Undertake the construction phase in a way that:

- » Ensures that construction activities are appropriately managed in respect of environmental aspects and impacts.
- » Enables construction activities to be undertaken without significant disruption to other land uses and activities in the area, in particular concerning noise impacts, farming practices, traffic and road use, and effects on local residents.
- » Minimises the impact on the indigenous natural vegetation, and habitats of ecological value.
- » Minimises impacts on fauna (including birds) in the study area.
- » Minimises the impact on heritage sites should they be uncovered.
- » Establish an environmental baseline during construction activities on the site, where possible.

6.1 Institutional Arrangements: Roles and Responsibilities for the Construction Phase

As the proponent, the Developer must ensure that the project complies with the requirements of all environmental authorisations and permits, and obligations emanating from other relevant environmental legislation. This obligation is partly met through the development of the EMPr, and the implementation of the EMPr through its integration into the contract documentation. The Developer will retain various key roles and responsibilities during the construction phase.

OBJECTIVE 1: Establish clear reporting, communication, and responsibilities in relation to the overall implementation of the EMPr

Formal responsibilities are necessary to ensure that key procedures are executed. Specific responsibilities of the Technical Director/Manager, Site Manager, Internal Environmental Officer, Safety and Health Representative, Independent Environmental Control Officer (ECO) and Contractor for the construction phase of this project are as detailed below. Formal responsibilities are necessary to ensure that key procedures are executed. **Figure 6.1** provides an organogram indicating the organisational structure for the implementation of the EMPr.

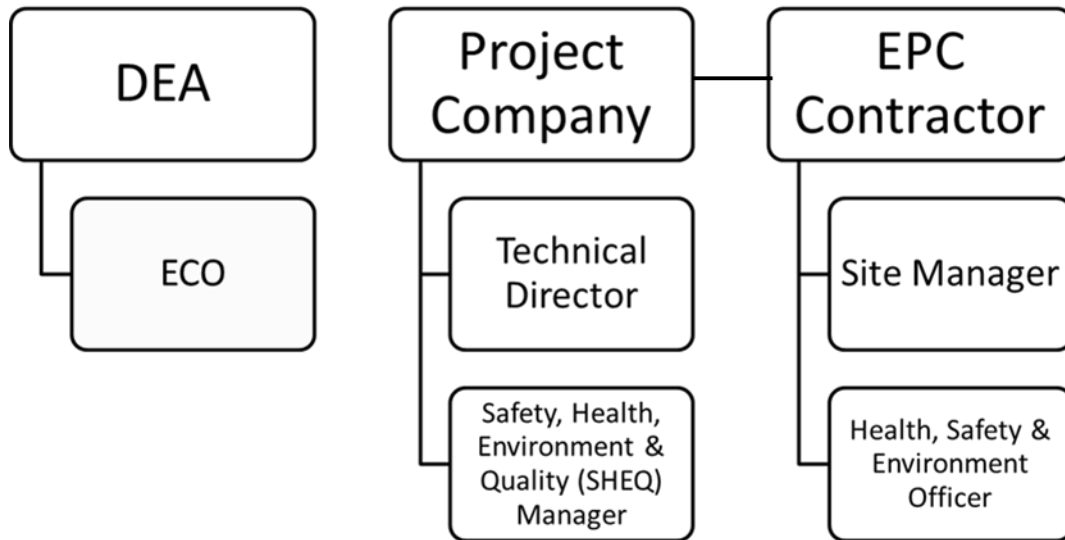

Figure 6.4: Organisational structure for the implementation of the EMPr

Construction Manager will:

- » Ensure all specifications and legal constraints specifically with regards to the environment are highlighted to the Contractor(s) so that they are aware of these.
- » Ensure that the Developer and its Contractor(s) are made aware of all stipulations within the EMPr.
- » Ensure that the EMPr is correctly implemented throughout the project by means of site inspections and meetings. This will be documented as part of the site meeting minutes through input from the independent ECO.
- » Be fully conversant with the EIA for the project, the EMPr, the conditions of the Environmental Authorisation, and all relevant environmental legislation.
- » Be fully knowledgeable with the contents of all relevant licences and permits.

Site Manager (The Contractors' on-site Representative) will:

- » Be fully knowledgeable with the contents of the EIA.
- » Be fully knowledgeable with the contents and conditions of the Environmental Authorisation.
- » Be fully knowledgeable with the contents of the EMPr.
- » Be fully knowledgeable with the contents of all relevant environmental legislation, and ensure compliance with these.
- » Have overall responsibility of the EMPr and its implementation.
- » Conduct audits to ensure compliance to the EMPr.
- » Ensure there is communication with the Technical Director, the ECO, the Internal Environmental Officer and relevant discipline engineers on matters concerning the environment.
- » Be fully knowledgeable with the contents of all relevant licences and permits.
- » Ensure that no actions are taken which will harm or may indirectly cause harm to the environment, and take steps to prevent pollution on the site.
- » Confine activities to the demarcated construction site.

An independent **Environmental Control Officer (ECO)** must be appointed by the project proponent prior to the commencement of any authorised activities and will be responsible for monitoring, reviewing and verifying compliance by the Contractor with the environmental specifications of the EMPr and the conditions of the Environmental Authorisation. Accordingly, the ECO will:

- » Be fully knowledgeable with the contents of the EIA.
- » Be fully knowledgeable with the contents and the conditions of the Environmental Authorisation.
- » Be fully knowledgeable, maintain, update and review the EMPr.
- » Be fully knowledgeable of all the licences and permits issued for the site.
- » Be fully knowledgeable with the contents of all relevant environmental legislation, and ensure compliance with them.
- » Provide environmental induction training to contractors on site prior to commencing of construction activities (this can also be undertaken by the EO).
- » Ensure that the contents of this document are communicated to the Contractor site staff and that the Site Manager and Contractor are constantly made aware of the contents through discussion.
- » Ensure that the compliance of the EMPr, EA and the legislation is monitored through regular and comprehensive inspection of the site and surrounding areas.
- » Compilation of the Environmental Audit Report or Environmental Completion Statement, six months after completion of construction or at a frequency in compliance with the Environmental Authorisation. Reports should be submitted to the relevant authority and the Project Proponent.
- » Monitoring and verification must be implemented to ensure that environmental impacts are kept to a minimum, as far as possible.
- » Ensure that the Site Manager has input into the review and acceptance of construction methods and method statements.
- » Keep record of all activities on site, problems identified, transgressions noted and a task schedule of tasks undertaken by the ECO. Reports should be submitted to the relevant authority on a monthly basis.
- » Ensure that the compilation of progress reports for submission to the Technical Director, with input from the Site Manager, takes place on a regular basis, including a final post-construction audit.
- » Ensure that there is communication with the Site Manager regarding the monitoring of the site.
- » Attendance of contractors site meetings.
- » ECO site inspections to be undertaken once a month to ensure compliance with the EMPr. The duration of these visits may be increased or decreased at the discretion of the ECO in consultation with the Engineers Representative.
- » Submit independent reports to the DEFF and other regulating authorities regarding compliance with the requirements of the EMPr, EA and other environmental permits.
- » The ECO must keep record of all activities on site, problems identified, transgressions noted and a schedule of tasks undertaken by the ECO (daily diary).

As a general mitigation strategy, the Environmental Control Officer (ECO) should be present for the site preparation and initial clearing activities to ensure the correct demarcation of no-go areas, facilitate environmental induction with construction staff and supervise any flora relocation and faunal rescue activities that may need to take place during the site clearing (i.e. during site establishment, and excavation of foundations). Thereafter, weekly site compliance inspections would probably be sufficient, which must be increased if required. However, in the absence of the ECO there should be a designated owner's environmental officer present to deal with any environmental issues that may arise such as fuel or oil spills. The ECO shall remain employed until all rehabilitation measures, as required for implementation due to construction damage, are completed and the site handed over for operation.

Contractors and Service Providers: It is important that Contractors are aware of the responsibilities in terms of the relevant environmental legislation and the contents of this EMPr. The Contractor will appoint an Internal Environmental Officer (EO) who will be responsible for informing contractor employees and sub-contractors of their environmental obligations in terms of the environmental specifications, and for ensuring that employees are adequately experienced and properly trained in order to execute the works in a manner that will minimise environmental impacts. The Internal Environmental Officer and Contractor's obligations in this regard include the following:

- » Must be fully knowledgeable on all environmental features of the construction site and the surrounding environment.
- » Be fully knowledgeable with the contents and the conditions of the Environmental Authorisation.
- » Be fully knowledgeable with the contents with the EMPr.
- » Be fully knowledgeable of all the licences and permits issued for the site.
- » Ensure a copy of the Environmental Authorisation and EMPr is easily accessible to all on-site staff members.
- » Ensure contractor employees are familiar with the requirements of this EMPr and the environmental specifications as they apply to the construction of the proposed facility.
- » Ensure that prior to commencing any site works, all contractor employees and sub-contractors must have attended environmental awareness training included in the induction training which must provide staff with an appreciation of the project's environmental requirements, and how they are to be implemented.
- » Ensure that any complaints received from the public are duly recorded and forwarded to the Site Manager and Contractor.
- » Manage the day-to-day on-site implementation of this EMPr, and the compilation of regular (usually weekly) Monitoring Reports.
- » Keep record of all activities on site, problems identified, transgressions noted and a task schedule of tasks undertaken, including those of the Independent ECO.
- » Inform staff of the environmental issues as deemed necessary by the Independent ECO.

All contractors (including sub-contractors and staff) and service providers are ultimately responsible for:

- » Ensuring adherence to the environmental management specifications.
- » Ensuring that Method Statements are submitted to the Site Manager (and ECO) for approval before any work is undertaken.
- » Ensuring that any instructions issued by the Site Manager on the advice of the ECO are adhered to.
- » Ensuring that a report is tabled at each site meeting, which will document all incidents that have occurred during the period before the site meeting.
- » Ensuring that a register is kept in the site office, which lists all transgressions issued by the ECO.
- » Ensuring that a register of all public complaints is maintained.
- » Ensuring that all employees, including those of sub-contractors, receive training before the commencement of construction in order for the sub-contractors to constructively contribute towards the successful implementation of the EMPr (i.e. ensure their staff are appropriately trained on the environmental obligations).

6.2 Objectives

In order to meet the overall goal for construction, the following objectives, actions, and monitoring requirements have been identified.

OBJECTIVE 2: Minimise impacts related to inappropriate site establishment

The Contractor must take all reasonable measures to ensure the safety of the public in the surrounding area. Where the public could be exposed to danger by any of the works or site activities, the contractor must, as appropriate, provide suitable flagmen, barriers and/or warning signs in English, Afrikaans and any other relevant local languages, all to the approval of the Site Manager.

All unattended open excavations shall be adequately demarcated and/or fenced. Adequate protective measures must be implemented to prevent unauthorised access to the working area and the internal access/haul routes.

Project Component/s	<ul style="list-style-type: none"> » Area infrastructure (i.e. PV panels, substation, <u>BESS (footprint as well as the battery units)</u> inverters, transformers, switchgear and ancillary buildings). » Linear infrastructure (i.e. underground cabling, power line and internal access roads and fencing).
Potential Impact	<ul style="list-style-type: none"> » Hazards to landowners and the public. » Damage to indigenous natural vegetation, due largely to ignorance of where such areas are located. » Loss of threatened plant species. » Visual impact of general construction activities, and the potential scarring of the landscape due to vegetation clearing and resulting erosion.
Activities/Risk Sources	<ul style="list-style-type: none"> » Any unintended or intended open excavations (foundations and cable trenches). » Movement of construction vehicles in the area and on-site. » The viewing of the construction of the PV facilities by visually sensitive observers.
Mitigation: Target/Objective	<ul style="list-style-type: none"> » To secure the site against unauthorised entry. » To protect members of the public/landowners/residents. » No loss of or damage to sensitive vegetation in areas outside the immediate development footprint. » Minimal visual intrusion by construction activities and intact vegetation cover outside of the immediate construction work areas.

Mitigation: Action/Control	Responsibility	Timeframe
Secure site, working areas and excavations in an appropriate manner.	Contractor	Site establishment, and duration of construction
Ensure that vegetation is not unnecessarily cleared or removed during the construction phase.	Contractor	Site establishment, and duration of construction
Reduce the construction phase through careful logistical planning and productive implementation of resources.	Contractor	Construction

Mitigation: Action/Control	Responsibility	Timeframe
Restrict the activities and movement of construction workers and vehicles to the immediate construction site and existing access roads.	Contractor	Construction
<u>Ensure battery transport and installation is undertaken by accredited service providers as well as personnel.</u>	<u>Contractor</u>	<u>Construction</u>
Ensure that rubble, litter, and disused construction materials are appropriately stored (if not removed daily) and then disposed regularly at licensed waste facilities.	Contractor	Construction
Reduce and control construction dust through the use of approved dust suppression techniques as and when required (i.e. whenever dust becomes apparent).	Contractor	Construction
Restrict construction activities to daylight hours in order to negate or reduce the visual impacts associated with lighting.	Contractor	Construction
Rehabilitate all disturbed areas, construction areas, servitudes, etc. immediately after the completion of construction works. If necessary, an ecologist should be consulted to assist or give input into rehabilitation specifications.	Contractor	Construction
Adequate protective measures must be implemented to prevent unauthorised access to the working area and the internal access routes. The development (including the development footprint and contractor's equipment camp) must also be secured and fenced and clearly demarcated.	Contractor	Site establishment, and duration of construction
The electrical fencing should be constructed in a manner which allows for the passage of small and medium sized mammals and small avifauna. Steel palisade fencing (20 cm gaps min) is a good option in this regard as it allows most medium-sized mammals to pass between the bars, but remains an effective obstacle for humans. Alternatively, the lowest strand or bottom of the fence should be elevated to 30cm above the ground which should be sufficient to allow smaller animals, reptiles and tortoises to pass through (tortoises retreat into their shells when electrocuted and eventually succumb from repeated shocks), but still remain effective as a security barrier.	Contractor	Site establishment
The construction camp used to house equipment must be located in a disturbed area and must be screened off as far as practical during the entire construction phase.	Contractor	Erection: during site establishment Maintenance: for duration of Contract
Establish appropriately bunded areas for storage of hazardous materials (i.e. fuel to be required during construction).	Contractor	Site establishment
Visual impacts must be reduced during construction through minimising areas of surface disturbance, controlling erosion, using dust suppression techniques, and restoring exposed soil as closely as possible to their original contour and vegetation.	Contractor	Site establishment, and duration of construction
Cleared alien vegetation must not be dumped on adjacent intact vegetation during clearing but must be temporarily stored in a demarcated area.	Contractor	Site establishment, and duration of construction
Establish the necessary ablution facilities with chemical toilets and provide adequate sanitation facilities and ablutions for construction workers so that the surrounding environment is not	Contractor	Site establishment, and duration of construction

Mitigation: Action/Control	Responsibility	Timeframe
polluted (at least one sanitary facility for each sex and for every 30 workers as per the 2014 Construction Regulations; Section 30(1) (b)) at appropriate locations on site). The facilities must be placed within the construction area and along the road.		
Ablution or sanitation facilities must not be located within 100m from a watercourse or within the 1:100 year flood.	Contractor	Site establishment, and duration of construction
Supply adequate weather and vermin proof waste collection bins and skips (covered at minimum with secured netting or shade cloth) at the site where construction is being undertaken. Separate bins should be provided for general and hazardous waste. Provision should be made for separation of waste for recycling.	Contractor	Site establishment, and duration of construction
Foundations and trenches must be backfilled to originally excavated materials as much as possible. Excess excavation materials must be disposed of only in approved areas, or, if suitable, stockpiled for use in reclamation activities.	Contractor	Site establishment, and duration of construction and rehabilitation

Performance Indicator	<ul style="list-style-type: none"> » Site is secure and there is no unauthorised entry. » No members of the public/ landowners injured. » Appropriate and adequate waste management and sanitation facilities provided at construction site. » Vegetation cover on and in the vicinity of the site is intact (i.e. full cover as per natural vegetation within the environment) with no evidence of degradation or erosion.
Monitoring	<ul style="list-style-type: none"> » An incident reporting system is used to record non-conformances to the EMP. » ECO to monitor all construction areas on a continuous basis until all construction is completed. Non-conformances will be immediately reported to the site manager. » Monitoring of vegetation clearing during construction (by contractor as part of construction contract). » Monitoring of rehabilitated areas quarterly for at least a year following the end of construction (by contractor as part of construction contract).

OBJECTIVE 3: Appropriate management of the construction site and construction workers

At the peak of construction the proposed project is likely to create a maximum of 400 employment opportunities. These employment opportunities will be temporary, and will last for a period of approximately 18 months (i.e. the length of construction). Employment opportunities generated during the construction phase will include low skilled, semi-skilled, and skilled opportunities. Solar PV projects make use of large numbers of unskilled and semi-skilled labour so there will be good opportunity to use local labour from the surrounding towns.

Security personnel will be deployed on a shift basis. Contractors and their employees are expected to be accommodated at existing accommodation facilities in the study area and surrounding towns. Construction equipment will need to be stored at appropriate locations on site.

In order to minimise impacts on the surrounding environment, contractors must be required to adopt a certain Code of Conduct and commit to restricting construction activities to areas within the development footprint. Contractors and their sub-contractors must be familiar with the conditions of the Environmental Authorisation, the EIA Report, and this EMPr, as well as the requirements of all relevant environmental legislation.

Project Component/s	<ul style="list-style-type: none"> » PV facility. » <u>BESS</u>. » Contractors' camp. » Laydown areas. » Access roads » Power line. » On-site substation. » Ancillary buildings.
Potential Impact	<ul style="list-style-type: none"> » Damage to indigenous natural vegetation and sensitive areas. » Damage to and/or loss of topsoil (i.e. pollution, compaction etc.). » Impacts on the surrounding environment due to inadequate sanitation and waste removal facilities. » Pollution/contamination of the environment.
Activities/Risk Sources	<ul style="list-style-type: none"> » Vegetation clearing and levelling of equipment storage area/s. » Access to and from the equipment storage area/s. » Ablution facilities. » Contractors not aware of the requirements of the EMPr, leading to unnecessary impacts on the surrounding environment.
Mitigation: Target/Objective	<ul style="list-style-type: none"> » Limit equipment storage within demarcated designated areas. » Ensure adequate sanitation facilities and waste management practices. » Ensure appropriate management of actions by on-site personnel in order to minimise impacts to the surrounding environment.

Mitigation: Action/Control	Responsibility	Timeframe
All construction vehicles must adhere to clearly defined and demarcated roads. No driving outside of the development boundary must be permitted.	Contractor	Construction
The siting of the construction equipment camp/s must take cognisance of any sensitive areas identified in the EIA Report. The location of this construction equipment camp/s must be approved by the project EO.	Contractor	Pre-construction
As far as possible, minimise vegetation clearing and levelling for equipment storage areas.	Contractor	Site establishment, and during construction
Practical phased development and vegetation clearing must be practiced so that cleared areas are not left un-vegetated and vulnerable to erosion for extended periods of time.	Contractor	Site establishment, and during construction
Road borders must be regularly maintained to ensure that vegetation remains short to serve as an effective firebreak. An emergency fire plan (refer to Appendix I) must be developed with emergency procedures in the event of a fire.	Contractor	Erection: during site establishment Maintenance: duration of contract
Rehabilitate all disturbed areas at the construction equipment camp as soon as construction is complete within an area.	Contractor	Duration of Contract

Mitigation: Action/Control	Responsibility	Timeframe
Ensure waste storage facilities are maintained and emptied on a regular basis.	Contractor	Site establishment, and duration of construction
No liquid waste, including grey water, may be discharged into any water body or drainage line. All sewage disposal to take place at a registered and operational wastewater treatment works. Proof of disposal to be retained as proof of responsible disposal.	Contractor	Maintenance: duration of contract within a particular area
Ensure that all personnel have the appropriate level of environmental awareness and competence to ensure continued environmental due diligence and on-going minimisation of environmental harm. This can be achieved through the provision of appropriate environmental awareness training to all personnel. Records of all training undertaken must be kept.	Contractor	Duration of construction
Ensure compliance with all national, regional and local legislation with regard to the storage, handling and disposal of hydrocarbons, chemicals, solvents and any other harmful and hazardous substances and materials.	Contractor	During construction.
Ensure ablution facilities are appropriately maintained. Ablutions must be cleaned regularly and associated waste disposed of at a registered/permitted waste disposal site. Ablutions must be removed from site when construction is completed.	Contractor and sub-contractor/s	Duration of contract
Cooking and eating of meals must take place in a designated area. No fires are allowed on site. No firewood or kindling may be gathered from the site or surrounds.	Contractor and sub-contractor/s	Duration of contract
All litter must be deposited in a clearly marked, closed, animal-proof disposal bin in the construction area. Particular attention needs to be paid to food waste.	Contractor and sub-contractor/s	Duration of contract
Keep a record of all hazardous substances stored on site. Clearly label all the containers storing hazardous waste.	Contractor	Duration of contract
A Method Statement should be compiled for the management of pests and vermin within the site, specifically relating to the canteen area if applicable.	Contractor	Construction
No disturbance of flora or fauna must be undertaken outside of the demarcated construction area/s.	Contractor and sub-contractor/s	Duration of contract
Fire-fighting equipment and training must be provided before the construction phase commences.	Contractor and sub-contractor/s	Duration of contract
Workers must be aware of the importance of not polluting rivers or wetlands (especially those located outside of the project site) and the significance of not undertaking activities that could result in such pollution, and this awareness must be promoted throughout the construction phase.	Contractor and EO	Pre-construction Construction
Contractors must ensure that all workers are informed at the outset of the construction phase of the conditions contained on the Code of Conduct, specifically consequences of stock theft and trespassing on adjacent farms.	Contractor and sub-contractor/s	Pre-construction

Mitigation: Action/Control	Responsibility	Timeframe
On completion of the construction phase, all construction workers must leave the site within one week of their contract ending.	Contractor and sub-contractor/s	Construction

Performance Indicator	<ul style="list-style-type: none"> » The construction camps have avoided sensitive areas. » Ablution and waste removal facilities are in a good working order and do not pollute the environment due to mismanagement. » All areas are rehabilitated promptly after construction in an area is complete. » Excess vegetation clearing and levelling is not undertaken. » No complaints regarding contractor behaviour or habits. » Appropriate training of all staff is undertaken prior to them commencing work on the construction site. » Code of Conduct drafted before commencement of the construction phase.
Monitoring	<ul style="list-style-type: none"> » Regular audits of the construction camps and areas of construction on site by the EO. » Proof of disposal of sewage at an appropriate licensed wastewater treatment works. » Proof of disposal of waste at an appropriate licensed waste disposal facility. » An incident reporting system should be used to record non-conformances to the EMPr. » Observation and supervision of Contractor practices throughout the construction phase by the EO. » Complaints will be investigated and, if appropriate, acted upon.

OBJECTIVE 4: Maximise local employment and business opportunities associated with the construction phase

Limited employment opportunities will be created during the construction phase, specifically for semi-skilled and unskilled workers. Employment of locals and the involvement of local SMMEs would enhance the social benefits associated with the project, even if the opportunities are only temporary. The procurement of local goods could furthermore result in positive economic spin-offs.

Project Component/s	» Construction activities associated with the establishment of the PV facility(<u>including the BESS</u>).
Potential Impact	» The opportunities and benefits associated with the creation of local employment and business should be maximised.
Activities/Risk Sources	<ul style="list-style-type: none"> » Contractors who make use of their own labour for unskilled tasks, thereby reducing the employment and business opportunities for locals. » The inflow of various specialists from outside the study area and even abroad. » Sourcing of individuals with skills similar to the local labour pool outside the municipal area.
Enhancement: Target/Objective	» The developer should aim to employ as many low-skilled and semi-skilled workers from the local area as possible. This should also be made a requirement for all contractors.

Mitigation: Action/Control	Responsibility	Timeframe
Employment of local community members (i.e. source labour from within the municipal area focused on the communities in closest proximity to the site) should be undertaken where possible.	Developer, Local Municipality, and Contractor	Duration of construction

Mitigation: Action/Control	Responsibility	Timeframe
A broad-based approach should be followed to identify and involve relevant organisations which could assist the main contractor and developer in identifying people whose skills may correspond with the required job specifications.	Developer, Local Municipality, and Contractor	Pre-construction
An equitable process should be promoted whereby locals and previously disadvantaged individuals (including women) are considered for employment opportunities.	Developer, and Local Municipality	Duration of construction
Create conditions that are conducive for the involvement of entrepreneurs, small businesses, and SMMEs during the construction process.	Developer, Local Municipality, and Contractor	Pre-construction
Identify potential opportunities for local businesses.	Developer	Pre-construction
Tender documentation (if any are required) should contain guidelines for the involvement of labour, entrepreneurs, businesses, and SMMEs from the local sector.	Developer Contractor	Pre-construction
A local labour desk should be set-up (if not already established) in the beneficiary communities to co-ordinate the process of involving local labour.	Developer Contractor	Pre-construction
Skills training and capacity building should be embarked upon from the onset of the construction phase and even prior to the construction phase if possible (as mentioned above)	Developer Contractor	Pre-construction and construction
Communication efforts concerning job creation opportunities should refrain from creating unrealistic expectations.	Developer	Pre-construction and construction

Performance Indicator	<ul style="list-style-type: none"> » Job opportunities, especially of low to semi-skilled positions, are primarily awarded to members of local communities as appropriate. » Locals and previously disadvantaged individuals (including women) are considered during the hiring process. » Labour, entrepreneurs, businesses, and SMMEs from the local sector are awarded jobs, where possible, based on requirements in the tender documentation. » The involvement of local labour is promoted. » Reports are not made from members of the local communities regarding unrealistic employment opportunities or that only outsiders were employed. » Employment and business policy document that sets out local employment and targets is completed before the construction phase commences.
Monitoring	<ul style="list-style-type: none"> » Monitor indicators listed above to ensure that they have been met for the construction phase. » The developer and EPC contractor must keep a record of local recruitments and information on local labour to be shared with the ECO for reporting purposes.

OBJECTIVE 5: Maximise capacity building and skills training, and address economic inequities within the study area

As the construction phase would involve unskilled, semi-skilled, and skilled workers, it is likely that locals could be sourced for the unskilled and semi-skilled positions. Due to the unemployment figures in the study area, it is clear that there would be various unemployed persons in search of employment, even if they can only secure temporary positions. For the lower level skilled positions, outsiders would therefore not have to be

externally sourced. Even though all that would be employed might not have the necessary applicable skills, this issue could be addressed through proper focussed skills training and capacity building initiatives after locals have been sourced, but prior to the commencement of construction activities.

Project Component/s	» Availability of required skills in the local communities for the undertaking of the construction activities.
Potential Impact	» The opportunities and benefits associated with the creation of local employment and business could be maximised.
Activities/Risk Sources	» Unavailability of locals with the required skills resulting in locals not being employed and labour being sourced from outside the municipal area. » Higher skilled positions might be sourced internationally, where required.
Mitigation: Target/Objective	» Employment of a maximum number of the low-skilled and/or semi-skilled workers from the local area where possible. » Appropriate skills training and capacity building

Mitigation: Action/Control	Responsibility	Timeframe
The developer, in discussions with the local municipality, should aim to employ a maximum number of the low-skilled and/or semi-skilled workers from the local area where possible.	The developer, Contractor, and Local Municipality	Duration of construction
A broad-based approach should be followed to identify and involve relevant organisations in identifying people whose skills may correspond with the job specifications.	Contractor, and Local Municipality	Pre-construction
In cases for the semi-skilled jobs, where the relevant skills do not exist, training should be provided to willing local community members to enable them to fill the positions.	The developer, Contractor, and Local Municipality	Duration of construction
A proactive consultative skills-audit should be undertaken in the local communities where job creation is currently a significant need.	The developer, and Local Municipality	Pre-construction, and construction
Appropriate training should be provided as per a decided upon skills development plan to narrow the gap between skills and demand. It is preferable that training be of such a nature that the skills thereby acquired are transferable and of real benefit in other employment contexts.	The developer, and Local Municipality	Pre-construction, and construction

Performance Indicator	» A skills development plan is developed. » Job opportunities, especially of lower skilled positions, are primarily awarded to members of local communities. » Skills training and capacity building initiatives are developed and implemented. » Local SMMEs and/or entrepreneurs awarded the opportunity to become involved in the tender process.
Monitoring	» Developer and or appointed ECO must monitor the indicators listed above to ensure that they have been implemented.

OBJECTIVE 6: Minimise the impact of the inflow of an outside workforce and job seekers into the study area

The inflow of jobseekers to the proposed site would be the greatest during the peak construction period of the PV facility, but also when the construction activities of the other large construction projects are becoming less intensive. Other possible negative impacts due to the workforce's presence in the area and especially when jobseekers come to the area would include misconduct of workers, trespassing of workers on privately owned farms, the possible increase in crime, littering, increase in traffic, increase in noise, the development of informal vending stations, and poaching of livestock.

Project Component/s	» Inflow of an outside workforce and jobseekers.
Potential Impact	» The inflow of outsiders and jobseekers could result in negative impacts on the surrounding property owners and local communities, and could lead to conflict between the locals and these outsiders.
Activities/Risk Sources	» Outside workforce and jobseekers come into conflict with the locals, and their presence leads to environmental pollution and the possibility of them remaining in the area (without proper housing facilities) after construction has ceased. This would put additional pressure on the existing infrastructure and services. » Locals are not employed, which would increase the probability of conflict occurring.
Mitigation: Target/Objective	» A limited number of outsiders employed. » Pro-active measures in place to deal with possible jobseekers.

Mitigation: Action/Control	Responsibility	Timeframe
Implement a transparent approach and open consultation with adjacent property owners, prior and throughout the construction period in order to provide a platform where grievances or requests can be addressed before issues become contentious.	Contractor	Pre-construction, construction
Local labourers should remain at their existing residences.	Contractor	Construction
On-site security should be active prior to the construction phase.	The developer	Pre- construction
Construction workers should be easily identifiable by wearing uniforms and even identity tags.	Contractor	Construction
Sufficient water and sanitation facilities should be provided for the workers on site during the construction phase.	Contractor	Construction
The construction site should be properly managed to avoid any environmental pollution (due to inadequate water, sanitation and waste infrastructure and services) and littering.	Contractor	Construction
The applicant, local leaders, and the Local Municipality should jointly develop a strategy to minimise the influx of jobseekers to the area.	The developer, local leaders and Local Municipality	Pre-construction, construction
Informal vending stations should not be allowed on or near the construction site.	Contractor	Construction
Develop a transparent communication and recruitment process to minimise the influx of jobseekers to the area.	The developer, and Contractor	Pre-construction
The recruitment process and the use of contractors should be clearly communicated to the local communities.	The developer	Pre-construction

Performance Indicator	<ul style="list-style-type: none"> » Locals are employed where possible. » Reports are not made from members of the local communities regarding unrealistic employment opportunities and/or negative intrusions or even possible increase in crime. » Sound environmental management of the construction site. » No conflict between outsiders, jobseekers, and local community members.
Monitoring	<ul style="list-style-type: none"> » Appointed ECO must monitor indicators listed above to ensure that they have been implemented.

OBJECTIVE 7: Minimise impacts related to traffic management and transportation of equipment and materials to site

It is estimated that the total number of heavy vehicle trips for a 100MW PV facility would vary between 4500 and 6000. These trips would be more over the 12-18 month construction period, which could result in 15 to 25 daily trips to the site. The impact of the trip generation would however be negligible as the additional peak hourly traffic would be up to 2 trips which would have no significant impact on the existing traffic service levels.

Project Component/s	<ul style="list-style-type: none"> » Delivery of any component required for the construction phase of the PV facility.
Potential Impact	<ul style="list-style-type: none"> » Impact of heavy construction vehicles on road surfaces, and possible increased risk in accidents involving people and animals. » Traffic congestion, particularly on narrow roads or on road passes where overtaking is not permitted. » Deterioration of road pavement conditions (both surfaced and gravel road) due to abnormal loads.
Activities/Risk Sources	<ul style="list-style-type: none"> » Construction vehicle movement. » Speeding on local roads. » Degradation of local road conditions. » Site preparation and earthworks. » Foundations or plant equipment installation. » Transportation of ready-mix concrete to the site. » Mobile construction equipment movement on-site.
Mitigation: Target/Objective	<ul style="list-style-type: none"> » Minimise impact of traffic associated with the construction of the facility on local traffic volumes, existing infrastructure, property owners, animals, and road users. » To minimise potential for negative interaction between pedestrians or sensitive users and traffic associated with the facility construction. » To ensure all vehicles are roadworthy and all materials/equipment are transported appropriately and within any imposed permit/licence conditions

Mitigation: Action/Control	Responsibility	Timeframe
Compile and implement a construction period traffic management plan for the site access roads to ensure that no hazards would result from the increased truck traffic and that traffic flow would not be adversely impacted (refer to Appendix F).	The developer and EO	Pre-construction
Gravel roads should be sprayed with water to limit dust creation if feasible and reasonable from an environmental perspective	Contractor and EO	Construction

Mitigation: Action/Control	Responsibility	Timeframe
(water scarce area), or an appropriate dust suppressant should be used.		
Access roads and entrances to the site should be carefully planned to limit any intrusion on the neighbouring property owners and road users.	The developer and EO	Planning and design
Construction vehicles and those transporting materials and goods should be inspected by the contractor or a sub-contractor to ensure that these are in good working order and not overloaded.	Contractor	Construction
Strict vehicle safety standards should be implemented and monitored.	The developer, Contractor and EO	Construction
A designated access to the proposed site must be used to ensure safe entry and exit.	Contractor	Pre-construction
No deviation from approved transportation routes must be allowed, unless roads are closed for whatever reason outside the control of the contractor.	Contractor	Duration of contract
Appropriate road management strategies must be implemented on external and internal roads with all employees and contractors required to abide by standard road and safety procedures.	Contractor (or appointed transportation contractor)	Pre-construction
Any traffic delays because of construction traffic must be co-ordinated with the appropriate authorities.	Contractor	Duration of contract
Signage must be established at appropriate points warning of turning traffic and the construction site (all signage to be in accordance with prescribed standards).	Contractor	Duration of contract
Appropriate maintenance of all vehicles of the contractor must be ensured.	Contractor	Duration of contract
All vehicles of the contractor travelling on public roads must adhere to the specified speed limits and all drivers must be in possession of an appropriate valid driver's license.	Contractor	Duration of contract
Keep any new hard road surfaces as narrow as possible.	Contractor	Duration of contract
All construction vehicles must remain on properly demarcated roads. No construction vehicles must be allowed to drive over the vegetation except where no clear roads are available. In such cases a single track must be used and multiple paths must not be formed.	Contractor	Duration of contract
Stagger infrastructure delivery to the site.	Contractor	Duration of contract
Staff and general trips must occur outside of peak traffic periods.	Contractor	Duration of contract
Construction materials to be sourced from local suppliers as much as possible to limit the impact on the regional road network	Contractor	Duration of contract

Performance Indicator	<ul style="list-style-type: none"> » Vehicles keeping to the speed limits. » Vehicles are in good working order and safety standards are implemented. » Local residents and road users are aware of vehicle movements and schedules. » No construction traffic related accidents are experienced. » Local road conditions and road surfaces are up to standard.
------------------------------	--

	» Complaints of residents are not received (e.g. concerning the speeding of heavy vehicles).
Monitoring	» Developer and or appointed EO must monitor indicators listed above to ensure that they have been implemented.

OBJECTIVE 8: Minimise the potential impact on health, safety and security

An inflow of workers could, as a worst case scenario and irrespective of the size of the workforce, pose some security risks. Criminals could also use the opportunity due to “outsiders” being in the area to undertake their criminal activities. Employing local community members could minimise the potential for criminal activity or perceived perception of an increase in criminal activity due to the presence of an outside workforce.

The actual safety of construction workers is also of concern. Further health and safety issues associated with the actual construction site include unauthorised entry to the site and construction areas, the usage of large equipment on site, the risks associated with the storage of equipment and material on site, as well as the increased risk of accidents due to the increased movement of construction vehicles on the local roads.

Other concerns relate to littering, unwanted behaviour of construction workers, transmission of Sexually Transmitted Diseases (STDs), environmental pollution, an increased risk etc. Although such perceptions cannot be substantiated or be changed it should be sensitively dealt with. It is therefore clear that even though the construction phase, when these impacts could occur, is only of a short duration the effects of the impacts could remain.

Project Component/s	» PV panels. » <u>BESS</u> . » Contractors' camps. » Access roads. » Laydown areas. » Power line.
Potential Impact	» Workers not from the local areas are involved in criminal activities and/or fires occur. » Inflow of workers could result in increased safety and security risks.
Activities/Risk Sources	» Theft of construction material. » On-site accidents. » Spread of sexually transmitted diseases. » Littering and environmental pollution.
Mitigation: Target/Objective	» Employment of local labour should be maximised and strict security measures should be implemented at the construction site.

Mitigation: Action/Control	Responsibility	Timeframe
Employing local community members could minimise the potential for criminal activity or perceived perception of an increase in criminal activity due to the presence of an outside workforce.	Contractor	Pre-construction
Screening of applicants could lessen perceived negative perceptions about the outside workforce.	Contractor	Pre- construction

Mitigation: Action/Control	Responsibility	Timeframe
All staff should undergo a general Health and Safety induction and simplified environmental awareness training session	Contractor (and sub-contractor/s)	Duration of contract
Safety representatives, managers and workers must be trained in workplace safety. The construction process must be compliant with all safety and health measures as prescribed by the relevant act.	Contractor (and sub-contractor/s)	Duration of contract
Local community members and property owners should be informed of the presence of the outside workforce, the construction schedule, and movement of workers.	Developer and Contractor	Construction
Procedures and measures to prevent, and in worst cases, attend to fires, must be developed in consultation with the surrounding property owners and the Local Municipality	Developer, Local Municipality, and local communities	Pre- construction and when required
Contact details of emergency services should be prominently displayed on site.	Contractor	Construction
Appropriate fire-fighting equipment must be present on site and members of the workforce should be appropriately trained in using this equipment in the fighting of veld fires.	Contractor	Construction
The construction site should be properly managed to avoid any environmental pollution (due to inadequate water, sanitation and waste infrastructure and services) and littering.	Contractor	Construction
Construction activities should not interfere with the activities on surrounding properties.	Contractor	Construction

Performance Indicator	<ul style="list-style-type: none"> » No criminal activities and theft of livestock attributable to the construction workforce are reported. » Limited intrusions on surrounding property owners. » No reports from property owners regarding problems with construction activities and workforce. » No fires or on-site accidents occur.
Monitoring	<ul style="list-style-type: none"> » The Developer and appointed ECO must monitor indicators listed above to ensure that they have been implemented.

OBJECTIVE 9: Minimise the potential impact on the daily living and movement patterns

Changes or disruptions in the daily living and working activities of residents, especially the landowner, are most likely to occur during the construction phase and are likely to include the following:

- » *Noise and dust pollution* - During the construction phase, limited gaseous or particulate emissions are anticipated from exhaust emissions from construction vehicles and equipment on-site, as well as vehicle entrained dust from the movement of vehicles on the site as well as main and internal access roads. The intensity of the negative impacts, would, however depend on the wind direction and timing of construction activities.
- » *Transportation routes* - The number of vehicles resulting from the proposed project.

Project Component/s	<ul style="list-style-type: none"> » Construction activities associated with the PV facility, <u>the BESS</u> and linear infrastructure. » Vegetation clearing. » Delivery of any component required within the construction phase.
Potential Impact	<ul style="list-style-type: none"> » Impact of heavy construction vehicles on road surfaces, and possible increased risk in accidents involving people and animals. » Traffic congestion, particularly on narrow roads or on road passes where overtaking is not permitted. » Deterioration of road pavement conditions (both surfaced and gravel road) due to abnormal loads. » Possible increase in dust, noise, and general intrusion.
Activities/Risk Sources	<ul style="list-style-type: none"> » Clearing of vegetation and topsoil. » Excavation, grading, scraping, levelling, digging, drilling. » Transport of materials, equipment, and components on internal access roads. » Re-entrainment of deposited dust by vehicle movements. » Wind erosion from topsoil and spoil stockpiles and unsealed roads and surfaces. » Fuel burning vehicle and construction engines.
Mitigation: Target/Objective	<ul style="list-style-type: none"> » Limit any negative impacts on the surrounding property owners' daily living and movement patterns. » Minimise impact of traffic associated with the construction of the facility on local traffic volume, existing infrastructure, property owners, animals, and road users. » Minimise nuisance to the community from dust emissions and to comply with workplace health and safety requirements for the duration of the construction phase

Mitigation: Action/Control	Responsibility	Timeframe
Adequate parking for all employees, contractors and sub-contractors must be made available and should not impact negatively on neighbouring farmers.	Contractor	Pre-construction and construction
Local labourers should be used during the construction phase to limit the inflow of outsiders to the area.	Contractor	Construction
Compile and implement a traffic management plan (Refer to Appendix F) for the site access roads to ensure that no hazards would result from the increased truck traffic and that traffic flow would not be adversely impacted.	Contractor	Pre-construction
Strict vehicle safety standards should be implemented and monitored.	Developer	Construction
Should abnormal loads have to be transported by road to the site, a permit must be obtained from the relevant Provincial Government.	Contractor (or appointed transportation contractor)	Pre-construction
No deviation from approved transportation routes must be allowed, unless roads are closed for whatever reason outside the control of the contractor.	Contractor	Duration of contract
Appropriate road management strategies must be implemented on external and internal roads with all employees and contractors required to abide by standard road and safety procedures.	Contractor (or appointed transportation contractor)	Pre-construction
Signs must be placed along construction roads to identify speed limits, travel restrictions, and other standard traffic control information. To minimise impacts on local commuters consideration must be given to limiting construction vehicles	Contractor	Duration of contract

Mitigation: Action/Control	Responsibility	Timeframe
travelling on public roadways during the morning and late afternoon commute time.		
Ensure that any damage to internal roads because of construction activities is repaired before completion of the construction phase.	Contractor	Duration of contract
Haul vehicles moving outside the construction site carrying material that can be wind-blown must be covered with suitable material.	Contractor	Duration of contract
Speed of construction vehicles must be restricted, as defined by the contractor.	Contractor	Duration of contract
Dust-generating activities or earthworks may need to be rescheduled or the frequency of application of dust control/suppressant increased during periods of high winds if visible dust is blowing toward nearby residences outside the site.	Contractor	Duration of contract
Dust suppression techniques must be implemented on all exposed surfaces during periods of high wind. Such measures may include wet suppression, chemical stabilisation, the use of a wind fence, covering surfaces with straw chippings and re-vegetation of open areas.	Contractor	Duration of contract

Performance Indicator	<ul style="list-style-type: none"> » No complaints from affected residents or the community regarding dust or vehicle emissions. » Dust does not cause health (inhaling, eye irritation) and safety risks (low visibility). » Dust suppression measures implemented for all areas that require such measures during the construction phase commences. » Drivers made aware of the potential safety issues and enforcement of strict speed limits when they are employed. » All heavy vehicles equipped with speed monitors before they are used in the construction phase in accordance with South African vehicle legislation. » Road worthy certificates in place for all heavy vehicles at the outset of construction phase and up-dated on a monthly basis. » A complaints register must be maintained, in which any complaints from neighbouring farmers will be logged, and thereafter complaints will be investigated and, where appropriate, acted upon.
Monitoring	<p>Monitoring must be undertaken to ensure emissions are not exceeding the prescribed levels via the following methods:</p> <ul style="list-style-type: none"> » Immediate reporting to the Site Manager by personnel of any potential or actual issues with nuisance, dust or emissions. » A complaints register must be maintained, in which any complaints from residents/the community will be logged, and thereafter complaints will be investigated and, where appropriate, acted upon. » An incident and non-conformance register must be used to record incidents and non-conformances to the EMPr.

OBJECTIVE 10: Minimisation of the development footprint and disturbance of topsoil

Project Component/s	<ul style="list-style-type: none"> » PV Panels » Underground cabling » Ancillary buildings » Access roads » On-site substation » Power line
Potential Impact	<ul style="list-style-type: none"> » Impacts on natural vegetation. » Loss of indigenous natural vegetation due to construction activities. » Impacts on soil. » Loss of topsoil
Activity/Risk Source	<ul style="list-style-type: none"> » Vegetation clearing » Site preparation and earthworks. » Excavation of foundations. » Construction of the internal access road. » Construction of underground cabling. » Construction of power line and on-site substation. » Site preparation (e.g. compaction). » Foundations or PV panel equipment installation. » Stockpiling of topsoil, subsoil and spoil material.
Mitigation: Target/Objective	<ul style="list-style-type: none"> » To retain natural vegetation, where possible. » To minimise footprints of disturbance of vegetation/habitats on-site » Remove and store all topsoil on areas that are to be excavated; and use this topsoil in subsequent rehabilitation of disturbed areas. » Minimise loss of topsoil. » Minimise spoil material.

Mitigation: Action/Control	Responsibility	Timeframe
In order to minimise impacts on flora, fauna, and ecological processes, the development footprint should be limited.	EO and Contractor	Site establishment and duration of contract
Land clearance must only be undertaken immediately prior to construction activities and unnecessary land clearance must be avoided.	Contractor	Construction
In terms of best practice and for rehabilitation purposes, it is essential that a 150mm layer of topsoil from the building footprints (i.e. the on-site substation and contractor's site camp) be stripped and stockpiled prior to the commencement of construction activities in each area.	EO and Contractor	Site establishment and duration of contract
The extent of clearing and disturbance to the natural vegetation must be kept to a minimum so that impact on flora and fauna is restricted.	Contractor	Site establishment and duration of contract
Areas to be cleared must be clearly marked on-site to eliminate the potential for unnecessary clearing. No vegetation removal must be allowed outside the designated project development footprint.	Contractors in consultation with the EO	Duration of Construction

Mitigation: Action/Control	Responsibility	Timeframe
Mitigation measures must be implemented to reduce the risk of erosion and the invasion of alien species.	EO and Contractor	Site establishment and duration of contract
No-Go areas are to be demarcated with tape and warning signs prohibiting access erected. Plant and vehicle operators must be instructed by the EO on where these No-Go sites are.	EO and Contractor	Construction
Topsoil must be removed and stored separately and must be reapplied where appropriate as soon as possible in order to encourage and facilitate rapid regeneration of the natural vegetation on cleared areas.	EO and Contractor	Construction
All fill material must be sourced from a commercial off-site suitable/permitted and authorised source, quarry or borrow pit. Where possible, material from foundation excavations must be used as fill on-site. Permits must be kept on site.	EO and Contractor	Duration of contract
Top soil and subsoil must be stockpiled separately and replaced according to the correct profile, i.e. topsoil replaced last. Stockpiles must not be situated such that they obstruct natural water pathways and drainage channels.	Contractor	Site establishment and duration of contract
Top soil stockpiles must not exceed 2m in height.	Contractor	Site establishment and duration of contract
Soil stockpiles must be dampened with dust suppressant or equivalent to prevent erosion by wind.	Contractor	Construction
Excavated topsoil must be stockpiled in designated areas separate from base material and covered until replaced during rehabilitation. As far as possible, topsoil must not be stored for longer than 3 months. Stockpiles older than 6 months must be enriched before they can be used to ensure the effectiveness of the topsoil.	Contractor	Site establishment and duration of contract
All graded or disturbed areas which will not be covered by permanent infrastructure such as paving, buildings or roads must be stabilised with erosion control mats (geo-textiles) and revegetated.	Contractor	Construction
Ridges and areas which include protected and red data species must be avoided at all costs during construction, unless the necessary permits are obtained.	EO	Pre-construction; Site establishment
Topsoil must not be stripped or stockpiled when it is raining or when the soil is wet as compaction will occur.	Contractor	Site establishment Maintenance: for duration of contract
Topsoil must be stockpiled and managed in terms of the erosion management plan (refer to Appendix G).	Contractor	Duration of contract
A site rehabilitation programme must be developed and implemented.	EO and Contractor in consultation with Ecologist	Duration of contract
Topsoil used for rehabilitation purposes should be reused to mitigate disturbed areas and should not be mixed with sub-soils.	EO and Contractor	Rehabilitation; Post-construction

Performance Indicator

- » Zero disturbance outside of designated work areas.
- » Minimise clearing of existing vegetation.
- » Topsoil appropriately stored.

Monitoring	<ul style="list-style-type: none"> » Observation of vegetation clearing activities by EO throughout construction phase. » Supervision of all clearing and earthworks. » An incident reporting system will be used to record non-conformances to the EMPr.
-------------------	--

OBJECTIVE 11: Minimise soil degradation and erosion and loss of land capability

The soil on site may be impacted in terms of:

- » Uncontrolled run-off relating to construction activity (excessive wetting, uncontrolled discharge, etc.) which will also lead to accelerated erosion;
- » Incorrect storage of topsoil;
- » Accidental spillages;
- » Poor rehabilitation;
- » Erosion from rainwater;
- » Soil degradation including erosion (by wind and water) and subsequent deposition elsewhere; and
- » Degradation of the natural soil profile due to excavation, stockpiling, compaction, pollution and other construction activities which will affect soil forming processes and associated ecosystems. Degradation of parent rock is considered low as there are no deep excavations envisaged.

Project Component/s	<ul style="list-style-type: none"> » PV Panels. » <u>BESS</u>. » Underground cabling. » Ancillary buildings. » Construction of the internal access roads. » Power line. » On-site substation.
Potential Impact	<ul style="list-style-type: none"> » Soil and rock degradation. » Soil erosion. » Increased deposition of soil into drainage systems. » Increased run-off over the site.
Activities/Risk Sources	<ul style="list-style-type: none"> » Removal of vegetation, excavation, stockpiling, compaction, and pollution of soil. » Creation of impenetrable surfaces. » Bare soils surfaces due to the removal of vegetation. » Earthworks which destroy the natural layers of the soil profiles. » The construction of access roads and PV panels and associated infrastructure which will cover soil surfaces. » Rainfall - water erosion of disturbed areas. » Wind erosion of disturbed areas. » High velocity discharge of water from construction activities.
Mitigation: Target/Objective	<ul style="list-style-type: none"> » Minimise extent of disturbed areas. » Minimise activity within disturbed areas. » Minimise soil degradation (mixing, wetting, compaction, etc.). » Minimise soil erosion. » Minimise instability of embankments/excavations. » Revegetate, maintain and monitor the site. » Keep the project footprint as small as possible.

Mitigation: Action/Control	Responsibility	Timeframe
Identify disturbed areas and restrict construction activity to these areas.	EO and Contractor	Before and during construction
Any erosion problems observed must be rectified immediately and monitored thereafter to ensure that they do not re-occur.	EO and Contractor	Construction Operation
All bare areas, affected by the development, must be re-vegetated with locally occurring species, to bind the soil and limit erosion potential.	EO and Contractor	Construction Rehabilitation
Re-instate as much of the eroded area to its pre-disturbed, "natural" geometry (no change in elevation).	EO and Contractor	Construction Rehabilitation
Roads and other disturbed areas must be regularly monitored for erosion problems and problem areas must receive follow-up monitoring by the EO to assess the success of the remediation.	EO and Contractor	Construction Rehabilitation
A method statement must be developed and submitted to the engineer to deal with erosion issues prior to bulk earthworks operations commencing	EO and Contractor	Before and during construction
During construction the contractor shall protect areas susceptible to erosion by installing necessary temporary and permanent drainage works as soon as possible and by taking other measures necessary to prevent the surface water from being concentrated in streams and from scouring the slopes, banks or other areas	EO and Contractor	During construction
Access roads to be carefully planned and constructed to minimise the impacted area and prevent unnecessary excavation, placement, and compaction of soil.	EO and Contractor	Design and construction
Minimise removal of vegetation which adds stability to soil.	EO and Contractor	Construction
Protective measures must be installed where there are possibilities of surface water sheet flow causing erosion.	EO and Contractor	Erection: Before construction Maintenance: Duration of contract
Stabilisation of cleared areas to prevent and control erosion must be actively managed. This includes: Brush cut packing, mulch or chip cover, straw stabilising, watering, planting/sodding, hand seed-sowing of locally-occurring indigenous species, hydroseeding of locally-occurring indigenous species, soil binders and anti-erosion compounds, gabion bolsters and mattresses for flow attenuation, geofabric, hessian cover and log/ pole fencing	EO and Contractor	Erection: Before construction Maintenance: Duration of contract
Erosion control measures: Run-off attenuation on slopes (sand bags, logs), silt fences, storm water catch-pits, shade nets, gabions or temporary mulching over denuded area as required.	EO and Contractor	Erection: Before construction Maintenance: Duration of contract
No soil is to be stripped from areas within the site that the contractor does not require for construction works.	EO and Contractor	Construction
Anti-erosion measures such as silt fences must be installed in disturbed areas.	Contractor	Construction
Erosion control measures to be regularly maintained.	EO and Contractor	Construction
Regular monitoring for erosion must take place to ensure that no erosion problems are occurring at the site as a result of the roads	EO and Contractor	Construction and operation

Mitigation: Action/Control	Responsibility	Timeframe
and other infrastructure. All erosion problems observed should be rectified as soon as possible as outlined in the erosion management plan (Appendix G).		
Performance Indicator	<ul style="list-style-type: none"> » No activity outside demarcated disturbance areas. » Limited soil erosion around site. » No activity in restricted areas. 	
Monitoring	<ul style="list-style-type: none"> » Limited level of soil erosion around the site. » Acceptable state of excavations, as determined by the EO. » Monthly inspections of sediment control devices by the EO. » Monthly inspections of surroundings, including washes (outside the development area) by the EO. » An incident reporting system will record non-conformances. » On-going visual assessment of compliance with erosion prevention by Contractor and ECO. » Monitor visual signs of erosion such as the formation of gullies after rainstorms and the presence of dust emissions during wind storms. » Any signs of soil erosion on site should be documented (including photographic evidence and coordinates of the problem areas) and submitted to the management team of the project. » Monitor compliance of construction workers to restrict construction work to the clearly defined limits of the construction site to keep footprint as small as possible. Monitoring to be undertaken by the ECO. 	

OBJECTIVE 12: Minimise the impacts on and loss of indigenous vegetation

Project Component/s	» Any infrastructure or activity that will result in disturbance to natural areas.
Potential Impact	» Loss of indigenous natural vegetation due to construction activities, or poor behaviour on the part of the construction team.
Activity/Risk Source	<ul style="list-style-type: none"> » Vegetation clearing. » Construction of the internal access roads. » Construction of the power line and on-site substation. » Chemical contamination of the soil by vehicles and machinery. » Operation of construction camps. » Storage of materials required for construction.
Mitigation: Target/Objective	<ul style="list-style-type: none"> » Minimise footprints of disturbance of vegetation/habitats. » Minimise loss of protected and indigenous vegetation. » Minimise loss of species of conservation concern.

Mitigation: Action/Control	Responsibility	Timeframe
Areas to be cleared must be clearly marked in the field to eliminate unnecessary clearing.	Contractor	Construction
Vegetation clearing must be limited to the required footprint for actual construction works and operational activities. No unnecessary vegetation must be cleared. Mitigation measures	Contractor	Construction

Mitigation: Action/Control	Responsibility	Timeframe
must be implemented to reduce the risk of erosion and the invasion of alien species.		
Limit unnecessary impacts on surrounding natural vegetation, e.g. driving around in the veld, use access roads only.	Contractor	Construction
Search and Rescue (S&R) of all protected plants that will be affected by the development (Appendix E), especially species occurring in long term and permanent, hard surface development footprints (i.e. all buildings, new roads and tracks, laydown areas, and panel positions), should take place. The necessary permits must be in place.	Contractor	Duration of construction
Monitor and control declared weeds and invader species. Continually monitor the re-emergence of these species and manage according to the invasive species management plan.	Contractor	Duration of construction

Performance Indicator	<ul style="list-style-type: none"> » No disturbance outside of designated work areas. » Minimised clearing of existing/natural vegetation. » Limited impacts on areas of identified and demarcated sensitive habitats/vegetation. » Ecosystem fragmentation is kept to a minimum. » Ecosystem functionality is retained and any degradation prevented. » Re-establishment of rescued species.
Monitoring	<ul style="list-style-type: none"> » Observation of vegetation clearing activities by ECO throughout construction phase. » Monitoring of vegetation clearing activities in terms of permit conditions. » Supervision of all clearing and earthworks. » An incident reporting system will be used to record non-conformances to the EMPr. » Where vegetation is not re-establishing itself in areas where surface disturbance occurred, soil samples must be collected, analysed for pH levels, electrical conductivity (EC) and major plant nutrient levels (calcium, magnesium, potassium) and sodium. » When vegetation re-establishment still remains unsatisfactory, the bulk density of the soil should be measured with a penetrometer to determine whether compaction is an issue. » The results must be submitted to a professional soil or agricultural scientist for recommendations on the amendment of the issue to ensure that the vegetation cover is established and erosion prevented.

OBJECTIVE 13: Minimise the establishment and spread of alien invasive plants

Major factors contributing to invasion by alien invader plants include high disturbance activities and negative grazing practices. Consequences of this may include:

- » Loss of indigenous vegetation;
- » Change in vegetation structure leading to change in various habitat characteristics;
- » Change in plant species composition;
- » Change in soil chemical properties;
- » Loss of sensitive habitats;
- » Loss or disturbance to individuals of rare, endangered, endemic, and/or protected species;
- » Fragmentation of sensitive habitats;
- » Change in flammability of vegetation, depending on alien species; and

» Hydrological impacts due to increased transpiration and runoff.

Project Component/s	<ul style="list-style-type: none"> » Solar facility. » Subcontractor's camps. » Power line. » On-site substation. » <u>BESS</u>. » Laydown areas. » Temporary access roads.
Potential Impact	<ul style="list-style-type: none"> » Invasion of natural vegetation surrounding the site by declared weeds or invasive alien species. » Impacts on soil. » Impact on faunal habitats. » Degradation and loss of agricultural potential.
Activities/Risk Sources	<ul style="list-style-type: none"> » Transport of construction materials to site » Movement of construction machinery and personnel » Site preparation and earthworks causing disturbance to indigenous vegetation » Construction of site access roads » Stockpiling of topsoil, subsoil and spoil material » Routine maintenance work – especially vehicle movement
Mitigation: Target/Objective	<ul style="list-style-type: none"> » To significantly reduce the presence of weeds and eradicate alien invasive species » To avoid the introduction of additional alien invasive plants to the site » To avoid further distribution and thickening of existing alien plants in the site » To complement existing alien plant eradication programs in gradually causing a significant reduction of alien plant species throughout the site

Mitigation: Action/Control	Responsibility	Timeframe
Avoid creating conditions in which alien plants may become established: <ul style="list-style-type: none"> » Keep disturbance of indigenous vegetation to a minimum. » Rehabilitate disturbed areas as quickly as possible. » Do not import soil from areas with alien plants. 	Contractor	Construction and operation
A suitably qualified contractor must be appointed to implement the Invasive Alien Plant (IAP) plan. PCO to appoint and supervise (on site) a qualified clearing team to implement the IAP management plan.	Contractor PCO	Construction
The IAP management plan must discuss the best practises for managing IAP and Weeds. EO will use this to monitor progress and methods used.	PCO EO	Construction
When alien plants are detected, these must be controlled and cleared using the recommended control measures for each species to ensure that the problem is not exacerbated or does not re-occur.	Contractor	Construction and operation
No plant propagules (seeds or otherwise) are to be introduced onto the site. Any soil to be introduced to the site must be from sites assessed by the IAP practitioner.	Contractor Specialist	Construction and operation
No herbicides must be recommended by anyone other than a registered PCO.	PCO	Construction and operation

Mitigation: Action/Control	Responsibility	Timeframe
Clearing methods must themselves aim to keep disturbance to a minimum.	Contractor	Construction
Establish an ongoing monitoring programme to detect and quantify any alien species that may become established and identify the problem species (as per Conservation of Agricultural Resources Act and Biodiversity Act)	Contractor	Construction and operation
Immediately control any alien plants that become established using registered control methods.	Contractor	Construction and operation

Performance Indicator	» For each alien species: number of plants and aerial cover of plants within the site and immediate surroundings.
Monitoring	<ul style="list-style-type: none"> » On-going monitoring of area by EO during construction. » On-going monitoring of area by environmental manager during operation. » Annual audit of development footprint and immediate surroundings by qualified botanist. » If any alien invasive species are detected then the distribution of these should be mapped (GPS co-ordinates of plants or concentrations of plants), number of individuals (whole site or per unit area), age and/or size classes of plants and aerial cover of plants. » The results should be interpreted in terms of the risk posed to sensitive habitats within and surrounding the site. » The environmental manager/site agent should be responsible for driving this process. » Reporting frequency depends on legal compliance framework.

OBJECTIVE 14: Minimise the impacts on fauna

Faunal species are indirectly affected by the overall loss of habitat as direct construction impacts can often limit the movement of individuals from the path of construction.

With respect to any threatened species, the loss of individuals or localised populations is unlikely to lead to a change in the conservation status of the species, unless they are classified as threatened. In the case of threatened animal species, the loss of a population or individual could lead to a direct change in its conservation status. This may arise if the proposed infrastructure is located where it will affect such individuals or populations or the habitat that they depend on. Consequences may include fragmentation of populations of affected species, reduction in area of occupancy of affected species, and loss of genetic variation within the affected species.

Project Component/s	<ul style="list-style-type: none"> » PV facility. » Power line. » On-site substation. » Contractor's camp and laydown area.
Potential Impact	<ul style="list-style-type: none"> » Loss or displacement of fauna. » Vegetation clearance and associated impacts on faunal habitats. » Traffic to and from site.
Activity/Risk Source	<ul style="list-style-type: none"> » Site preparation and earthworks. » Construction-related traffic.

	<ul style="list-style-type: none"> » Foundations or PV equipment installation. » Mobile construction equipment. » Underground cabling and road construction activities.
Mitigation: Target/Objective	<ul style="list-style-type: none"> » To minimise footprints of habitat destruction » To minimise disturbance to (and death of) resident and visitor faunal and avifaunal species

Mitigation: Action/Control	Responsibility	Timeframe
The extent of clearing and disturbance to the natural vegetation must be kept to a minimum so that impact on fauna and their habitats is restricted.	Contractor	Site establishment and duration of contract
Any fauna directly threatened by the construction activities must be removed to a safe location by a suitably qualified person.	Suitably qualified person	Construction
The collection, hunting or harvesting of any plants or animals at the site must be strictly forbidden. Personnel must not be allowed to wander off of the demarcated construction site.	Contractor	Construction
All construction vehicles must adhere to a low speed limit (30km/h) to avoid collisions with susceptible species such as snakes and tortoises.	Contractor	Construction Operation
A firebreak must be maintained around the development boundary to avoid potential fires occurring within the facility from spreading into the surrounding grasslands, subsequently posing a threat to faunal species occurring within the surrounding environment.	Contractor	Construction Operation
All hazardous materials must be stored in the appropriate manner to prevent contamination of the site. Any accidental chemical, fuel and oil spills that occur at the site must be cleaned up in the appropriate manner as related to the nature of the spill.	Contractor	Construction Operation
The intentional harming or killing of animals will be prohibited through on-site supervision and worksite rules.	Contractor	Construction Operation
Implement a faunal removal plan/ rescue plan with designated/ trained personnel and contact numbers.	Contractor	Duration of contract
<p>All cable trenches, excavations, etc., through sensitive areas should be excavated carefully in order to minimise damage to surrounding areas and biodiversity.</p> <ul style="list-style-type: none"> » The trenches must be checked on a daily basis for the presence of trapped animals. » Any animals found must be removed by a suitably qualified person in a safe manner, unharmed, and placed in an area where the animal will be comfortable. » All mammal, large reptiles and avifauna species found injured during construction must be taken to a suitably qualified veterinarian or rehabilitation centre to either be euthanized in a humane manner or cared for until it can be released again. 	Contractor	Duration of construction

Performance Indicator	<ul style="list-style-type: none"> » No disturbance outside of designated work areas » Minimised clearing of existing/natural vegetation and habitats for fauna » Limited impacts on faunal species (i.e. noted/recorded fatalities)
------------------------------	---

Monitoring	<ul style="list-style-type: none"> » Observation of vegetation clearing activities by EO throughout construction phase. » Supervision of all clearing and earthworks. » Recording faunal fatalities to monitor success of relocation efforts. » An incident reporting system will be used to record non-conformances to the EMPr.
-------------------	---

OBJECTIVE 15: Appropriate Stormwater Management

The stormwater management is covered under the Pre-construction and construction phase management, but aspects thereof will also continue into the Operation Phase. It is important that the engineers and contractors responsible for the detailed design of the Stormwater Systems take into account the requirements of this EMPr, as well as the recommendations by the participating specialists.

A Stormwater Management Plan is attached as **Appendix G**.

Project Component/s	» Alteration of natural areas into hard surfaces impacting on the local hydrological regime of the area.
Potential Impact	» Poor stormwater management and alteration of the hydrological regime.
Activities/Risk Sources	» Placement of hard engineered surfaces.
Mitigation: Target/Objective	» Reduce the potential increase in surface flow velocities and the impact on dry riverbeds and the localised drainage systems.

Mitigation: Action/Control	Responsibility	Timeframe
Any stormwater within the site must be handled in a suitable manner, i.e. clean and dirty water streams around the plant and install stilling basins to capture large volumes of run-off, shade nets, or gabions trapping sediments and reduce flow velocities.	Contractor/ Operator and Engineers	Planning, design and operation
Stormwater structures should as far as possible not concentrate runoff by piped systems or similar.	Contractor	Design Construction
All roads and other hardened surfaces must have runoff control features which redirect water flow and dissipate any energy in the water which may pose an erosion risk	Contractor	Design Construction
Stormwater control systems must be implemented to reduce erosion on the project site.	Contractor	Design Construction
New access roads within the site are to be constructed according to design and contract specifications. The access routes must have suitable stormwater management plans and erosion control measures.	Contractor	Design Construction
Drainage measures must promote the dissipation of storm water run-off.	Contractor/Operator Developer	Design Construction
All stormwater mitigation measures must be implemented according to the Stormwater Management Plan (Appendix G).	Contractor	Construction

Performance Indicator	<ul style="list-style-type: none"> » No impacts due to runoff » Minimise erosion as far as possible
Monitoring	» Appropriate stormwater management system in place

OBJECTIVE 16: Protection of heritage resources

The project site has been disturbed and transformed by agricultural activities which has led to the presence of pre-existing agricultural plough fields, grazing areas and farm buildings. Furthermore, throughout the agricultural areas within the project site, several heaps of rocks that have been removed from the agricultural fields were identified. No archaeological resources, graves⁵ or burial grounds were identified within the project site. In addition, no structures of heritage importance were recorded.

Considering the palaeontology of the project site, it was identified that the area in question is located within the Malmani Group which contains a number of stromatolitic dolomites. These were formed in warm shallow sea and are the accumulation of layer upon layer of minerals deposited by blue-green algae (also known as cyanobacteria) and rarely some filamentous algae. Minerals deposited by the algae include calcium carbonate, calcium sulphate and magnesium carbonate. Very rarely are the algal cells preserved in the stromatolites and these are microscopic. Stromatolites are essentially trace fossils and these ones are 2650 to 2750 million years old and very abundant. Based on the nature of the proposed development, construction activities may impact on fossil heritage should these features be preserved within the development footprint. The geological structures of the project site suggest that the rocks are much too old to contain fossils other than blue-green algae. Taking account of the defined criteria, the potential impact to fossil heritage resources is negligible to extremely low.

Project Component/s	<ul style="list-style-type: none"> » PV Panels. » <u>BESS</u>. » Transformers and switchgear etc. » Underground cabling. » Ancillary buildings. » Access roads. » Power line. » On-site substation.
Potential Impact	» Heritage objects or artefacts found on site are inappropriately managed or destroyed.
Activity/Risk Source	<ul style="list-style-type: none"> » Site preparation and earthworks » Foundations or plant equipment installation » Mobile construction equipment movement on site » Power line construction activities.
Mitigation: Target/Objective	» To ensure that any heritage objects found on site are treated appropriately and in accordance with the relevant legislation

Mitigation: Action/control	Responsibility	Timeframe
Areas required to be cleared during construction must be clearly marked in the field to avoid unnecessary disturbance of adjacent areas.	Contractor in consultation with Heritage Specialist	Pre-construction
A chance find procedure must be developed and implemented in the event that archaeological or palaeontological resources are found. In the case where the proposed development	Contractor ECO Heritage specialist	Pre-construction Construction

⁵ Graves are subterranean in nature and might not have been identified during the initial site visit undertaken by the specialist.

Mitigation: Action/control	Responsibility	Timeframe
activities bring these materials to the surface, work must cease and SAHRA must be contacted immediately.		
Contractors must be informed before construction starts on the possible types of heritage sites and cultural material they may encounter and the procedures to follow if they find sites. All staff should also be familiarised with procedures for dealing with heritage objects/sites.	Contractor, ESA and heritage specialist	Duration of contract, particularly during excavations
Familiarise all staff and contractors with procedures for dealing with heritage objects/sites.	Heritage Specialist	Pre-construction
Project employees and any contract staff must maintain, at all times, a high level of awareness of the possibility of discovering heritage sites.	Contractor	Duration of contract
In the event that fossils resources are discovered during excavations, immediately stop excavation in the vicinity of the potential material. Mark (flag) the position and also spoil that may contain fossils. Inform the site foreman and the EO. EO to inform the developer, the developer contacts the standby archaeologist and/or palaeontologist. EO to describe the occurrence and provide images by email.	Contractor and EO	Construction
If any evidence of archaeological sites or remains (e.g. remnants of stone-made structures, indigenous ceramics, bones, stone artefacts, ostrich eggshell fragments, charcoal and ash concentrations), fossils or other categories of heritage resources are found during the proposed development, SAHRA APM Unit (Natasha Higgitt/Phillip Hine 021 462 540) must be alerted. If unmarked human burials are uncovered, the SAHRA Burial Grounds and Graves (BGG) Unit (Thingahangwi Tshivhase/Mimi Seetelo 012 320 8490), must be alerted immediately as per section 35(3) and 36(6) of the NHRA. A professional archaeologist or paleontologist, depending on the nature of the finds, must be contracted as soon as possible to inspect the findings. If the newly discovered heritage resources prove to be of archaeological or paleontological significance, a Phase 2 rescue operation may be required subject to permits issued by SAHRA.	Contractor and ECO Heritage Specialist	Construction

Performance Indicator	<ul style="list-style-type: none"> » No disturbance outside of designated work areas » All heritage items located are dealt with as per the legislative guidelines
Monitoring	<ul style="list-style-type: none"> » Observation of excavation activities by the EO throughout construction phase » Supervision of all clearing and earthworks » Due care taken during earthworks and disturbance of land by all staff and any heritage objects found reported. » Appropriate permits obtained from SAHRA prior to the disturbance or destruction of heritage sites (if required). » An incident reporting system will be used to record non-conformances to the EMPr.

OBJECTIVE 17: Appropriate handling and management of waste

The construction of the PV facility, as well as the BESS, will involve the generation of various wastes. In order to manage the wastes effectively, guidelines for the assessment, classification, and management of wastes, along with industry principles for minimising construction wastes must be implemented. The main wastes expected to be generated by the construction of the PV facility will include:

- » general solid waste
- » hazardous waste
- » inert waste (rock and soil)
- » liquid waste (including grey water and sewage)

An integrated Waste Management Plan is attached as **Appendix H**.

Project Component/s	<ul style="list-style-type: none"> » PV Facility. » <u>BESS</u>. » Underground cabling. » Ancillary buildings. » Access roads. » Power line. » On-site substation.
Potential Impact	<ul style="list-style-type: none"> » Inefficient use of resources resulting in excessive waste generation. » Litter or contamination of the site or water through poor waste management practices.
Activity/Risk Source	<ul style="list-style-type: none"> » Packaging » Other construction wastes » Hydrocarbon use and storage » Spoil material from excavation, earthworks and site preparation
Mitigation: Target/Objective	<ul style="list-style-type: none"> » To comply with waste management legislation » To minimise production of waste » To ensure appropriate waste storage and disposal » To avoid environmental harm from waste disposal » A waste manifests should be developed for the ablutions showing proof of disposal of sewage at appropriate water treatment works.

Mitigation: Action/Control	Responsibility	Timeframe
Construction method and materials should be carefully considered in view of waste reduction, re-use, and recycling opportunities.	Contractor	Duration of contract
Construction contractors must provide specific detailed waste management plans to deal with all waste streams.	Contractor	Duration of contract
Waste disposal at the construction site must be avoided by separating and trucking out of waste.	Contractor	Construction
Specific areas must be designated on-site for the temporary management of various waste streams, i.e. general refuse, construction waste (wood and metal scrap), and contaminated waste as required. Location of such areas must seek to minimise	Contractor	Duration of contract

Mitigation: Action/Control	Responsibility	Timeframe
the potential for impact on the surrounding environment, including prevention of contaminated runoff, seepage, and vermin control.		
Where practically possible, construction and general wastes on-site must be reused or recycled. Bins and skips must be available on-site for collection, separation, and storage of waste streams (such as wood, metals, general refuse etc.).	Contractor	Duration of contract
Disposal of waste must be in accordance with relevant legislative requirements, including the use of licensed contractors.	Contractor	Duration of contract
<u>Damaged and used batteries should be removed from site by the supplier or accredited service provider for recycling or appropriate disposal.</u>	<u>Contractor</u>	<u>Duration of contract</u>
Uncontaminated waste must be removed at least weekly for disposal, if feasible; other wastes must be removed for recycling/ disposal at an appropriate frequency.	Contractor	Duration of contract
Hydrocarbon waste must be contained and stored in sealed containers within an appropriately bunded area and clearly labelled.	Contractor	Duration of contract
Waste must be kept to a minimum and must be transported by approved waste transporters to sites designated for their disposal.	Contractor	Duration of contract
No liquid waste, including grey water, may be discharged into any water body or drainage line. All sewage disposal to take place at a registered and operational wastewater treatment works. Slips of disposal to be retained as proof of responsible disposal.	Contractor	Maintenance: duration of contract within a particular area
Ensure compliance with all national, regional and local legislation with regard to the storage, handling and disposal of hydrocarbons, chemicals, solvents and any other harmful and hazardous substances and materials. The onus is on the Contractor to identify and interpret the applicable legislation. Hazardous waste to be disposed of at a registered landfill site.	Contractor	During and post construction.
Documentation (waste manifest) must be maintained detailing the quantity, nature, and fate of any regulated waste. Waste disposal records must be available for review at any time.	Contractor	Duration of contract
SABS approved spill kits to be available and easily accessible.	Contractor	Duration of contract
Regularly serviced chemical toilet facilities and/or septic tank must be used to ensure appropriate control of sewage.	Contractor	Duration of contract
Daily inspection of all chemical toilets and septic tanks must be performed by environmental representatives on site.	Contractor	Duration of contract
In the event where sewage is discharged into the environment, all contaminated vegetation/ rock and soil must be removed immediately and treated as hazardous waste.	Contractor	Duration of construction
Ensure that the below ground storage of the septic tank can withstand the external forces of the surrounding pressure. The area above the tank must be demarcated to prevent any vehicles or heavy machinery from driving around the tank.	Contractor	Duration of construction
Under no circumstances may waste be burnt on site.	Contractor	Duration of construction

Mitigation: Action/Control	Responsibility	Timeframe
Where a registered waste site is not available close to the construction site, provide a method statement with regard to waste management.	Contractor	Duration of construction
Waste manifests must be provided for all waste streams generated on site, and must be kept on site.	Contractor	Duration of construction
Implement an integrated waste management approach that is based on waste minimisation and incorporates reduction, recycling, re-use and disposal where appropriate. Where solid waste is disposed of, such disposal shall only occur at a landfill licensed in terms of section 20(b) of the National Environmental Management Waste Act, 2008 (Act 59 of 2008).	Contractor	Duration of construction
Upon the completion of construction, the area must be cleared of potentially polluting materials. Spoil stockpiles must also be removed and appropriately disposed of or the materials re-used for an appropriate purpose.	Contractor	Completion of construction
Upon the completion of construction, all sanitation facilities (including chemical toilets) must be removed, as well as the associated waste to be disposed of at a registered waste disposal site.	Contractor	Completion of construction

Performance Indicator	<ul style="list-style-type: none"> » No complaints received regarding waste on site or indiscriminate dumping. » Internal site audits ensuring that waste segregation, recycling and reuse is occurring appropriately. » Provision of all appropriate waste manifests for all waste streams. » <u>Used and/or damaged batteries are recycled or appropriately disposed of.</u>
Monitoring	<ul style="list-style-type: none"> » Observation and supervision of waste management practices throughout construction phase. » Waste collection will be monitored on a regular basis. » Waste documentation completed. » Proof of disposal of sewage at an appropriate wastewater treatment works. » A complaints register will be maintained, in which any complaints from the community will be logged. Complaints will be investigated and, if appropriate, acted upon. » An incident reporting system will be used to record non-conformances to the EMPr.

OBJECTIVE 18: Appropriate handling and storage of chemicals, hazardous substances

The construction phase may involve the storage and handling of a variety of chemicals including adhesives, abrasives, oils and lubricants, paints and solvents.

Project Component/s	<ul style="list-style-type: none"> » Laydown areas. » <u>BESS.</u> » Subcontractors' camps. » Temporary hydrocarbon and chemical storage areas.
Potential Impact	<ul style="list-style-type: none"> » Release of contaminated water from contact with spilled chemicals. » Generation of contaminated wastes from used chemical containers. » Soil pollution.

Activity/Risk Source	<ul style="list-style-type: none"> » Vehicles associated with site preparation and earthworks. » Construction activities of area and linear infrastructure. » Hydrocarbon spills by vehicles and machinery during levelling, vegetation clearance and transport of workers, materials and equipment and fuel storage tanks. » Accidental spills of hazardous chemicals. » Polluted water from wash bays and workshops. » Pollution from concrete mixing and damaged PV panels.
Mitigation: Target/Objective	<ul style="list-style-type: none"> » To ensure that the storage and handling of chemicals and hydrocarbons on-site does not cause pollution to the environment or harm to persons. » To ensure that the storage and maintenance of machinery on-site does not cause pollution of the environment or harm to persons. » Prevent and contain hydrocarbon leaks. » Undertake proper waste management. » Store hazardous chemicals safely in a bunded area.

Mitigation: Action/Control	Responsibility	Timeframe
Any liquids stored on site, including admixtures, fuels and lubricants, should be stored in accordance with applicable legislation.	Contractor	Pre-construction and implement for duration of Contract
Spill kits must be made available on-site for the clean-up of spills and leaks of contaminants.	Contractor	Duration of contract
Losses of fuel and lubricants from the oil sumps and steering racks of vehicles and equipment must be contained using a drip tray with plastic sheeting filled with absorbent material when not parked on hard standing.	Contractor	Construction Operation
Establish an appropriate Hazardous Stores which is in accordance with the Hazardous Substance Amendment Act, No. 53 of 1992. This should include but not be limited to: <ul style="list-style-type: none"> » Designated area; » All applicable safety signage; » Firefighting equipment; » Enclosed by an impermeable bund; » Protected from the elements, » Lockable; » Ventilated; and » Has adequate capacity to contain 110% of the largest container contents. 	Contractor	Pre-construction and implement for duration of Contract
Corrective action must be undertaken immediately if a complaint is made, or potential/actual leak or spill of polluting substance identified. This includes stopping the contaminant from further escaping, cleaning up the affected environment as much as practically possible and implementing preventive measures. Where required, a NEMA Section 30 report must be submitted to <u>DEFF</u> within 14 days of the incident.	Contractor	Duration of contract
In the event of a major spill or leak of contaminants, the relevant administering authority must be immediately notified as per the notification of emergencies/incidents.	Contractor	Duration of contract
Spilled concrete must be cleaned up as soon as possible and disposed of at a suitably licensed waste disposal site.	Contractor	Duration of contract

Mitigation: Action/Control	Responsibility	Timeframe
Accidental spillage of potentially contaminating liquids and solids must be cleaned up immediately in line with procedures by trained staff with the appropriate equipment.		
Any contaminated/polluted soil removed from the site must be disposed of at a licensed hazardous waste disposal facility.	Contractor	Duration of contract
Routine servicing and maintenance of vehicles must not to take place on-site (except for emergencies). If repairs of vehicles must take place, an appropriate drip tray must be used to contain any fuel or oils.	Contractor	Duration of contract
All stored fuels to be maintained within a bund and on a sealed surface as per the requirements of SABS 089:1999 Part 1.	Contractor	Duration of contract
Fuel storage areas must be inspected regularly to ensure bund stability, integrity, and function.	Contractor	Duration of contract
Construction machinery must be stored in an appropriately sealed area.	Contractor	Duration of contract
Oily water from bunds at the substation must be removed from site by licensed contractors.	Contractor	Duration of contract
Fuel storage areas must be inspected regularly to ensure bund stability, integrity, and function.	Contractor	Duration of contract
The storage of flammable and combustible liquids such as oils will be in designated areas which are appropriately banded, and stored in compliance with Material Safety Data Sheets (MSDS) files.	Contractor	Duration of contract
Any storage and disposal permits/approvals which may be required must be obtained, and the conditions attached to such permits and approvals will be compiled with.	Contractor	Duration of contract
Transport of all hazardous substances must be in accordance with the relevant legislation and regulations.	Contractor	Duration of contract
The sediment control and water quality structures used on-site must be monitored and maintained in an operational state at all times.	Contractor	Duration of contract
An effective monitoring system must be put in place to detect any leakage or spillage of all hazardous substances during their transportation, handling, installation and storage.	Contractor	Construction
Precautions must be in place to limit the possibility of oil and other toxic liquids from entering the soil or clean stormwater system.	Contractor	Construction

Performance Indicator	<ul style="list-style-type: none"> » No chemical spills outside of designated storage areas. » No water or soil contamination by spills. » No complaints received regarding waste on site or indiscriminate dumping. » Safe storage of hazardous chemicals. » Proper waste management.
Monitoring	<ul style="list-style-type: none"> » Observation and supervision of chemical storage and handling practices and vehicle maintenance throughout construction phase. » A complaints register must be maintained, in which any complaints from the community will be logged. » An incident reporting system will be used to record non-conformances to the EMPr.

	<ul style="list-style-type: none"> » On-going visual assessment to detect polluted areas and the application of clean-up and preventative procedures. » Monitor hydrocarbon spills from vehicles and machinery during construction continuously and record volume and nature of spill, location and clean-up actions. » Monitor maintenance of drains and intercept drains weekly. » Analyse soil samples for pollution in areas of known spills or where a breach of containment is evident when it occurs. » Records of accidental spills and clean-up procedures and the results thereof must be audited on an annual basis by the ECO. » Records of all incidents that caused chemical pollution must be kept and a summary of the results must be reported to management annually.
--	---

OBJECTIVE 19: Limit direct and indirect terrestrial faunal and avifaunal impacts

Project component/s	Construction activities and human presence.
Potential Impact	Disturbance of faunal communities due to construction as well as poaching and hunting risk from construction staff.
Activity/risk source	Habitat transformation during construction, site fencing, and the presence of construction and operation personnel.
Mitigation: Target/Objective	Low faunal impact during construction and operation.

Mitigation: Action/control	Responsibility	Timeframe
Environmental induction must be given to all staff regarding the impacts on fauna and avifauna.	Contractor	Construction and Operation
Apply systematic reflective/dynamic markers to the boundary fence to increase the visibility of the fence for approaching birds (e.g. korhaan taxa) and to avoid potential bird collisions with the fence structure.	Contractor	Construction
Concentrate all surface infrastructure on habitat of medium to low avifaunal sensitivity.	Contractor	Construction
All internal electrical reticulation should be placed underground, while the alignment of the power line and substation should be placed parallel to existing lines, as far as possible.	Contractor	Construction
<u>Where required, above-ground cables connecting to the BESS with the on-site facility substation should be covered with insulating material to prevent the risk of potential electrocutions should any large bird species interact in any manner with the BESS.</u>	Contractor	Construction
Where possible, retain a dense bush clump habitat as part of an open space system to provide refugia and perching platforms for "bushveld" bird species.	Contractor	Construction
EO to monitor and enforce ban on hunting, collecting or harvesting etc. of all plants and animals or their products.	EO	Construction and Operation

Mitigation: Action/control	Responsibility	Timeframe
All construction vehicles must adhere to a low speed limit to avoid collisions with susceptible species such as snakes and tortoises.	Contractor	Construction
Apply bird deterrent devices at selective areas (for example at the corners and middle part of the facility) to the PV panels to discourage birds from colonising the infrastructure or to discourage birds from constructing nests. These could include visual or bio-acoustic deterrents such as highly reflective rotating devices, anti-perching devices such as bird guards, scaring or chasing activities involving the use of trained dogs or raptors and/or netting.	Contractor	Construction
All new power lines should be fitted with bird flight diverters.	Contractor	Construction
Insulate live components at support structures.	Contractor	Construction

Performance Indicator	<ul style="list-style-type: none"> » Minimum disturbance outside of designated work areas. » Minimised clearing of existing/natural vegetation and habitats for fauna and avifauna. » Limited impacts on faunal species (i.e. noted/recorded fatalities), especially those of conservation concern.
Monitoring	» Monitoring for compliance during the construction phase. All incidents to be noted.

OBJECTIVE 20: Effective management of concrete batching plants

A considerable amount of concrete is required during the construction of the PV facility. In this regard there could be a need to establish a batching plant within the site. Turbid and highly alkaline wastewater, dust emissions and noise are the key potential impacts associated with concrete batching plants. Concrete batching plants, cement, sand and aggregates can produce dust. Potential pollutants in batching plant wastewater and stormwater include cement, sand, aggregates, chemical additive mixtures, fuels and lubricants.

Project component/s	<ul style="list-style-type: none"> » Batching plant. » Stormwater system.
Potential Impact	<ul style="list-style-type: none"> » Dust emissions » Release of contaminated water » Generation of contaminated wastes from used chemical containers » Inefficient use of resources resulting in excessive waste generation
Activity/risk source	<ul style="list-style-type: none"> » Operation of the batching plant » Packaging and other construction wastes » Hydrocarbon use and storage
Mitigation: Target/Objective	» To ensure that the operation of the batching plant does not cause pollution to the environment or harm to persons

Mitigation: Action/control	Responsibility	Timeframe
Concrete batching plants should be sited such that impacts on the environment or the amenity of the local community from noise, odour or polluting emissions are minimised.	Contractor	Construction phase

Mitigation: Action/control	Responsibility	Timeframe
Where there is a regular movement of vehicles, access and exit routes for heavy transport vehicles should be planned to minimise noise and dust impacts on the environment.	Contractor	Construction phase
Good maintenance practices must be implemented, including regular sweeping to prevent dust build-up	Contractor	Construction phase
The prevailing wind direction should be considered to ensure that bunkers and conveyors are sited in a sheltered position to minimise the effects of the wind.	Contractor	Construction phase
Aggregate material should be delivered in a damp condition, and water sprays or a dust suppression agent should be correctly applied to reduce dust emissions and reduce water usage.	Contractor	Construction phase
Process wastewater collected from the entire batching plant area should be diverted to an impervious settling tank or pond. Water should be reused in the concrete batching process, where possible.	Contractor	Construction phase
A contaminated stormwater system must be specifically designed for the batching plant to ensure effective control of contaminated stormwater originating from the batching plant and prevent contamination to the surrounding environment.	Contractor	Construction phase
Where possible, waste concrete should be used for construction purposes at the batching plant or project site.	Contractor	Construction phase
Artificial wind barriers must be installed around the batching plant to minimise air, land and water pollution. Wind barriers must enclose the entire batching plant and not allow fly ash and other dusts from moving through the barrier. The artificial barrier must be maintained daily for any defects and corrected when necessary.	Contractor	Pre-construction/ construction
The concrete wash bay structure must be constructed in a double brick arrangement or be reinforced to maintain its integrity throughout operation.	Contractor	Construction phase

Performance Indicator	<ul style="list-style-type: none"> » No complaints regarding dust » No water or soil contamination by chemical spills » No complaints received regarding waste on site or indiscriminate dumping
Monitoring	<ul style="list-style-type: none"> » Observation and supervision of chemical storage and handling practices and vehicle maintenance throughout construction phase. » A complaints register will be maintained, in which any complaints from the community will be logged. Complaints will be investigated and, if appropriate, acted upon. » An incident and non-conformance register will be used to record incidents and non-conformances to the EMP. » The appointed ECO must monitor indicators listed above to ensure that they have been met for the construction phase

OBJECTIVE 21: Enhancement of positive social impacts and mitigation of negative social impacts

During the construction phase of Lichtenburg 2, both positive and negative impacts are expected to occur. Positive impacts can be enhanced through the application of enhancement measures and negative impacts can be mitigated and the significance reduced through the application of mitigation measures.

Project component/s	» Construction of Lichtenburg 2 and the associated infrastructure
Potential Impact	<ul style="list-style-type: none"> » Opportunities and benefits associated with the creation of local employment and skills development to be maximised. » Potential local economic benefits. » Population changes resulting in additional pressure on resources, service delivery, infrastructure maintenance and social dynamics during the construction phase as a result of an influx of construction workers into the area. » Decline on local economic and social infrastructure and services as well as a rise in social conflicts from an influx of jobseekers. » Increase in traffic disruptions, safety hazards, and impacts on movement patterns of local community as well as impact on private property due to the upgrade of the existing road and heavy vehicle traffic in the local area. » Intrusion impacts could impact the area's "sense of place". » Heavy vehicles and construction activities can generate noise and dust impacts. » Increase in crime due to influx of non-local workforce and jobseekers into the area.
Activity/risk source	<ul style="list-style-type: none"> » Construction activities. » Construction procurement practice employed by the EPC Contractor. » Developers investment and procurement plans. » Influx of construction workers and jobseekers. » Construction activities affecting daily living and movement patterns. » Safety and security risks associated with construction activities.
Mitigation: Target/Objective	<ul style="list-style-type: none"> » The developer should aim to fill as many of the low-skilled and semi-skilled positions from the local area as possible. This should also be made a requirement for all contractors. » Increase in the procurement of goods and services, especially within the local economy. » To avoid or minimise the potential impact on local infrastructure, services and local communities and their livelihoods. » To avoid and minimise the potential noise and dust impacts associated with construction activities.

Mitigation: Action/control	Responsibility	Timeframe
Employ local contractors that are compliant with Broad Based Black Economic Empowerment (B-BBEE) criteria, as much as possible.	Developer Contractor	Construction
Adopt a local employment policy to maximise the opportunities made available to the local labour force.	Developer Contractor	Construction
In the recruitment selection process, a minimum percentage of women must be employed	Developer Contractor	Pre-construction Construction
Set realistic local recruitment targets for the construction phase.	Developer Contractor	Construction

Mitigation: Action/control	Responsibility	Timeframe
Source as much goods and services as possible from the local area. Engage with local authorities and business organisations to investigate the possibility of procurement of construction materials, goods and products from local suppliers where feasible.	Developer Contractor	Construction
Implement a grievance and communication system for community issues and appoint a Community Liaison Officer (CLO) for implementing the grievance mechanism. A method of communication should be implemented whereby procedures to lodge complaints are set out in order for the local community and landowners to express any complaints or grievances with the construction process.	Contractor	Construction
A 'locals first' policy should be utilised for employment opportunities, especially for semi and low-skilled job categories.	Contractor	Construction
Working hours must be kept during daylight hours as far as possible during the construction phase, and / or as any deviation that is approved by the relevant authorities.	Contractor	Construction
Implement penalties for drivers of heavy vehicles for reckless driving or speeding as a way to enforce compliance with traffic rules.	Contractor	Construction
Infrastructure such as fencing and gates along access routes must be maintained in the present condition or repaired if disturbed due to construction activities.	Contractor	Construction
Ensure roads utilised are either maintained in the present condition or restored if disturbed from construction activities.	Contractor	Construction
Limit noise generating activities to normal daylight working hours and avoid undertaken construction activities on weekends and public holidays.	Contractor	Construction
The movement of heavy vehicles associated with the construction phase should be timed to avoid weekends, public holidays and holiday periods where feasible.	Contractor	Construction
Dust suppression measures must be implemented for heavy vehicles such as wetting of gravel roads on a regular basis and ensuring that vehicles used to transport building materials are fitted with tarpaulins or covers.	Contractor	Construction
Communication, complaints and grievance channels must be implemented and contact details of the CLO are to be provided to the local community.	Contractor	Construction

Performance Indicator	<ul style="list-style-type: none"> » Employ as much local semi and unskilled labour as possible given the number of positions available. » Local goods and services are purchased from local suppliers where feasible. » Community Liaison Officer is appointed. » Ensure no recruitment takes place on site. » Control/removal of loiters. » Vehicles are roadworthy, inspected regularly and speed limits are adhered to. » Ensure that there are traffic warning signs along access roads, and ensure that these are well illuminated (especially at night).
------------------------------	--

	<ul style="list-style-type: none">» Roads and electric fencing are maintained or improved upon if disturbed from project activities.» Limit noise generating activities.» Dust suppression measures implemented for all heavy vehicles that require such measures during the construction phase.» Enforcement of strict speeding limits.» CLO available for community grievances and communication channel.» The construction site is appropriately secured with a controlled access system.
Monitoring	<ul style="list-style-type: none">» The Developer and Contractor must keep a record of local recruitments and information on local labour to be shared with the Environmental Control Officer (ECO) for reporting purposes.

6.3 Detailing Method Statements

OBJECTIVE 22: Ensure all construction activities are undertaken with the appropriate level of environmental awareness to minimise environmental risk

The environmental specifications are required to be underpinned by a series of Method Statements, within which the Contractors and Service Providers are required to outline how any identified environmental risks will practically be mitigated and managed for the duration of the contract, and how specifications within this EMPr will be met. That is, the Contractor will be required to describe how specified requirements will be achieved through the submission of written Method Statements to the Site Manager and ECO.

A Method Statement is defined as “a written submission by the Contractor in response to the environmental specification or a request by the Site Manager, setting out the plant, materials, labour and method the Contractor proposes using to conduct an activity, in such detail that the Site Manager is able to assess whether the Contractor’s proposal is in accordance with the Specifications and/or will produce results in accordance with the Specifications”. The Method Statement must cover applicable details with regard to:

- » Responsible person/s;
- » Construction procedures;
- » Materials and equipment to be used;
- » Getting the equipment to and from site;
- » How the equipment/material will be moved while on-site;
- » How and where material will be stored;
- » The containment (or action to be taken if containment is not possible) of leaks or spills of any liquid or material that may occur;
- » Timing and location of activities;
- » Compliance/non-compliance with the Specifications; and
- » Any other information deemed necessary by the Site Manager.

Method Statements must be compiled for all activities which affect any aspect of the environment and should be applied consistently to all activities. Specific areas to be addressed in the method statement: pre, during and post construction include:

- » Site establishment (which explains all activities from induction training to offloading, construction sequence for site establishment and the different amenities and to be established etc. Including a site camp plan indicating all of these).
- » Preparation of the site (i.e. clearing vegetation, compacting soils and removing existing infrastructure and waste).
- » Soil management/stockpiling and erosion control.
- » Excavations and backfilling procedure.
- » Stipulate norms and standards for water supply and usage (i.e.: comply strictly to licence and legislation requirements and restrictions).
- » Stormwater method statement.
- » Ablution facilities (placement, maintenance, management and servicing).
- » Solid Waste Management:
 - * Description of the waste storage facilities (on site and accumulative).
 - * Placement of waste stored (on site and accumulative).
 - * Management and collection of waste process.
 - * Recycle, re-use and removal process and procedure.
- » Liquid waste management.
- » Design, establish, maintain and operate suitable pollution control facilities necessary to prevent discharge of water containing polluting matter or visible suspended materials into the surrounding environment. Should grey water (i.e. water from basins, showers, baths, kitchen sinks etc.) need to be disposed of, link into an existing facility where possible. Where no facilities are available, grey water runoff must be controlled to ensure no seepage into the surrounding environment occurs.
- » Dust and noise pollution:
 - * Describe the necessary measures to ensure that noise from construction activities is maintained within lawfully acceptable levels.
 - * Procedure to control dust at all times on the site, access roads and spoil sites (dust control shall be sufficient so as not to have significant impacts in terms of the biophysical and social environments). These impacts include visual pollution, decreased safety due to reduced visibility, negative effects on human health and the ecology due to dust particle accumulation.
- » Hazardous substance storage (ensure compliance with all national, regional and local legislation with regard to the storage of oils, fuels, lubricants, solvents, wood treatments, bitumen, cement, pesticides and any other harmful and hazardous substances and materials. South African National Standards apply).
 - * Lists of all potentially hazardous substances to be used.
 - * Appropriate handling, storage and disposal procedures.
 - * Prevention protocol of accidental contamination of soil at storage and handling areas.
 - * All storage areas, (i.e. for harmful substances appropriately bunded with a suitable collection point for accidental spills must be implemented and drip trays underneath dispensing mechanisms including leaking engines/machinery).
- » Fire prevention and management measures on site.
- » Installation of the Battery Energy System.
- » Fauna and flora protection process on and off site (i.e. removal to reintroduction or replanting, if necessary).
 - * Rehabilitation, re-vegetation process and bush clearing.
- » Incident and accident reporting protocol.
- » General administration
- » Designate access road and the protocols while roads are in use.

- » Requirements on gate control protocols.

The Contractor may not commence the activity covered by the Method Statement until it has been approved by the Site Manager (with input from the ECO), except in the case of emergency activities and then only with the consent of the Site Manager. Approval of the Method Statement will not absolve the Contractor from their obligations or responsibilities in terms of their contract. Failure to submit a method statement may result in suspension of the activity concerned until such time as a method statement has been submitted and approved.

6.4 Awareness and Competence: Construction Phase

OBJECTIVE 23: To ensure all construction personnel have the appropriate level of environmental awareness and competence to ensure continued environmental due diligence and on-going minimisation of environmental harm

To achieve effective environmental management, it is important that all personnel involved in the project are aware of the responsibilities in terms of the relevant environmental legislation and the contents of this EMPr. The ECO is responsible for monitoring compliance pre, during and post construction. The contractor is responsible for informing employees and sub-contractors of their environmental obligations in terms of the environmental specifications, and for ensuring that employees are adequately experienced and properly trained in order to execute the works in a manner that will minimise environmental impacts.

The Contractors obligations in this regard include the following:

- » All Employees must have a basic understanding of the key environmental features of the construction site and the surrounding environment. This includes the discussion/explanation of site environmental matters during toolbox talks.
- » The content and requirements of Method Statements are to be clearly explained to all plant operators and general workers. All staff acting in a supervisory capacity are to have copies of the relevant Method Statements and be aware of the contents thereof.
- » Ensuring that a copy of the EMPr is readily available on-site, and that all senior site staff are aware of the location and have access to the document. Senior site staff will be familiar with the requirements of the EMPr and the environmental specifications as they apply to the construction of the facility.
- » Ensuring that, prior to commencing any site works, all employees and sub-contractors have attended an Environmental Awareness Training session. The training session must provide the site staff with an appreciation of the project's environmental requirements, and how they are to be implemented.
 - * Records must be kept of those that have completed the relevant training.
 - * Training should be done either in a written or verbal format but must be appropriate for the receiving audience.
 - * Refresher sessions must be held to ensure the contractor staff are aware of their environmental obligations as practically possible.
- » All sub-contractors must have a copy of the EMPr and sign a declaration/ acknowledgement that they are aware and familiar with the contents and requirements of the EMPr and that they will conduct work in such a manner as to ensure compliance with the requirements of the EMPr.
- » Contractors and main sub-contractors should have a basic training in the identification of archaeological sites/objects, and protected flora and fauna that may be encountered on the site.

- » Awareness of any other environmental matters, which are deemed to be necessary by the ECO.
- » Ensuring that employee information posters, outlining the environmental "do's" and "don'ts" (as per the environmental awareness training course) are erected at prominent locations throughout the site.

Therefore, prior to the commencement of construction activities on site and before any person commences with work on site thereafter, adequate environmental awareness and responsibility are to be appropriately presented to all staff present onsite, clearly describing their obligations towards environmental controls and methodologies in terms of this EMPr. This training and awareness will be achieved in the following ways:

6.4.1 Environmental Awareness and Induction Training

The EO, in consultation with the contractor, shall ensure that all construction workers receive an induction presentation, as well as on-going environmental education and awareness, on the importance and implications of the EMPr and the environmental requirements it prescribes. The presentation shall be conducted, as far as is possible, in the employees' language of choice. The contractor should provide a translator from their staff for the purpose of translating should this be necessary.

As a minimum, induction training should include:

- » Explanation of the importance of complying with the EMPr;
- » Explanation of the importance of complying with the Environmental Authorisation;
- » Discussion of the potential environmental impacts of construction activities;
- » Awareness regarding sensitivities on the site, including sensitive plant species (including the use of visual aids and on-site identification);
- » The benefits of improved personal performance;
- » Employees' roles and responsibilities, including emergency preparedness (this should be combined with this induction, but presented by the contractor's Health and Safety Representative);
- » Explanation of the mitigation measures that must be implemented when carrying out their activities; and
- » Explanation of the specifics of this EMPr and its specification (no-go areas, etc.).

Environmental Awareness Training must take the form of an on-site talk and demonstration by the EO/ECO before the commencement of site establishment and construction on site. The education/awareness programme should be aimed at all levels of management and construction workers within the contractor team. A record of attendance of this training must be maintained by the EO/ECO on site. Proof of awareness training should be kept on record. Environmental induction training must be presented to all persons who are to work on the site – be it for short or long durations; Contractor's or Engineer's staff; administrative or site staff; sub-contractors or visitors to site.

This induction training should be undertaken by the Contractor's Environmental Officer and should include discussing the developer's environmental policy and values, the function of the EMPr and Contract Specifications and the importance and reasons for compliance to these. The induction training must highlight overall do's and don'ts on site and clarify the repercussions of not complying with these. The non-conformance reporting system must be explained during the induction as well. Opportunity for questions and clarifications must form part of this training. A record of attendance of this training must be maintained by the EO/ECO on site.

6.4.2 Toolbox Talks

Toolbox talks should be held on a scheduled and regular basis (at least twice a month) where foremen, environmental and safety representatives of different components of the works and sub-consultants hold talks relating to environmental practices and safety awareness on site. These talks should also include discussions on possible common incidents occurring on site and ones recommended by the on site EO and the prevention of reoccurrence thereof. Records of attendance and the awareness talk subject must be kept on file.

6.5 Monitoring Programme: Construction Phase

OBJECTIVE 24: To monitor the performance of the control strategies employed against environmental objectives and standards

A monitoring programme must be in place not only to ensure conformance with the EMPr, but also to monitor any environmental issues and impacts which have not been accounted for in the EMPr that are, or could result in significant environmental impacts for which corrective action is required. The period and frequency of monitoring will be stipulated by the Environmental Authorisation (once issued). Where this is not clearly dictated, the Developer will determine and stipulate the period and frequency of monitoring required in consultation with relevant stakeholders and authorities. The Technical Director/ Project Manager will ensure that the monitoring is conducted and reported.

The aim of the monitoring and auditing process would be to monitor the implementation of the specified environmental specifications, in order to:

- » Monitor and audit compliance with the prescriptive and procedural terms of the environmental specifications
- » Ensure adequate and appropriate interventions to address non-compliance
- » Ensure adequate and appropriate interventions to address environmental degradation
- » Provide a mechanism for the lodging and resolution of public complaints
- » Ensure appropriate and adequate record keeping related to environmental compliance
- » Determine the effectiveness of the environmental specifications and recommend the requisite changes and updates based on audit outcomes, in order to enhance the efficacy of environmental management on site
- » Aid in communication and feedback to authorities and stakeholders

All documentation e.g. audit/monitoring/compliance reports and notifications, required to be submitted to the DEFF in terms of the Environmental Authorisation, must be submitted to the Director: Compliance Monitoring of the Department.

Records relating to monitoring and auditing must be kept on site and made available for inspection to any relevant and competent authority in respect of this development.

6.5.1. Non-Conformance Reports

All supervisory staff including Foremen, Engineers, and the ECO must be provided the means to be able to submit non-conformance reports to the Site Manager. Non-conformance reports will describe, in detail, the cause, nature and effects of any environmental non-conformance by the Contractor.

The non-conformance report will be updated on completion of the corrective measures indicated on the finding sheet. The report must indicate that the remediation measures have been implemented timeously and that the non-conformance can be closed-out to the satisfaction of the Site Manager and ECO.

6.5.2. Monitoring Reports

A monitoring report will be compiled by the ECO on a monthly basis and must be submitted to the Director: Compliance Monitoring at DEFF for their records. This report should include details of the activities undertaken in the reporting period, any non-conformances or incidents recorded, corrective action required, and details of those non-conformances or incidents which have been closed out. The contractor must ensure that all waste manifests are provided to the ECO on a monthly basis in order to inform and update the DEFF regarding waste related activities.

6.5.3. Audit Reports

The holder of the Environmental Authorisation must, for the period during which the Environmental Authorisation and EMPr remain valid, ensure that project compliance with the conditions of the Environmental Authorisation and the EMPr are audited, and that the audit reports are submitted to the Director: Compliance Monitoring of the DEA.

An environmental internal audit must be conducted and submitted every 3 months and an external audit must be conducted once a year. An annual audit report must be compiled and submitted to DEFF until the completion of the construction and rehabilitation. This report must be compiled in accordance with Appendix 7 of the EIA Regulations, 2014, as amended, and indicate the date of the audit, the name of the auditor and the outcome of the audit in terms of compliance with the environmental authorisation conditions and the requirements of the EMPr.

6.5.4. Final Audit Report

A final environmental audit report must be compiled by an independent auditor and be submitted to DEFF upon completion of the construction and rehabilitation activities, within 30 days of completion of rehabilitation activities. This report must indicate the date of the audit, the name of the auditor and the outcome of the audit in terms of compliance with the environmental authorisation conditions and the requirements of the EMPr.

CHAPTER 7: MANAGEMENT PROGRAMME: REHABILITATION

Overall Goal: Undertake the rehabilitation measures in a way that:

- » Ensures rehabilitation of disturbed areas following the execution of the works, such that residual environmental impacts are remediated or curtailed.

7.1. Objectives

In order to meet this goal, the following objective, actions and monitoring requirements are relevant:

OBJECTIVE 1: Ensure appropriate rehabilitation of disturbed areas such that residual environmental impacts are remediated or curtailed

Areas requiring rehabilitation will include all areas disturbed during the construction phase and that are not required for regular operation and maintenance operations. Rehabilitation should be undertaken in an area as soon as possible after the completion of construction activities within that area.

Project Component/s	<ul style="list-style-type: none"> » Construction camps. » Laydown areas. » Access roads. » Ancillary buildings. » Power line. » On-site substation. » <u>BESS</u>.
Potential Impact	» Environmental integrity of the site undermined resulting in reduced visual aesthetics, erosion and increased runoff, and the requirement for on-going management intervention.
Activity/Risk Source	<ul style="list-style-type: none"> » Temporary construction areas » Temporary access roads/tracks » Other disturbed areas/footprints
Mitigation: Target/Objective	<ul style="list-style-type: none"> » Ensure and encourage site rehabilitation of disturbed areas. » Ensure that the site is appropriately rehabilitated following the execution of the works, such that residual environmental impacts (including erosion) are remediated or curtailed.

Mitigation: Action/Control	Responsibility	Timeframe
Implement revegetation and rehabilitation plan (refer to Appendix D).	Contractor	Following execution of the works
All temporary facilities, equipment, and waste materials must be removed from site as soon as construction is completed.	Contractor	Following execution of the works
All temporary fencing and danger tape must be removed once the construction phase has been completed.	Contractor	Following completion of construction activities in an area
The area that previously housed the construction equipment camp is to be checked for spills of substances such as oil, paint, etc. and these must be cleaned up.	Contractor	Following completion of construction activities in an area

Mitigation: Action/Control	Responsibility	Timeframe
No planting or importing any listed invasive alien plant species (all Category 1a, 1b and 2 invasive species) to the site for landscaping, rehabilitation or any other purpose must be undertaken.	Contractor	Following completion of construction activities in an area
All hardened surfaces within the construction equipment camp area should be ripped, all imported materials removed, and the area shall be top soiled and re-vegetated.	Contractor	Following completion of construction activities in an area
Temporary roads must be closed and access across these blocked. The temporary access roads must be rehabilitated.	Contractor	Following completion of construction activities in an area
Necessary drainage works and anti-erosion measures must be installed, where required, to minimise loss of topsoil and control erosion.	Contractor	Following completion of construction activities in an area
All areas of disturbed soil must be reclaimed using only indigenous grass and shrubs.	Contractor	Following completion of construction activities in an area
Topsoil from all excavations and construction activities must be salvaged and reapplied during reclamation.	Contractor	Following completion of construction activities in an area
Disturbed areas must be rehabilitated as soon as possible after construction and local indigenous plants must be used to enhance the conservation of the existing natural vegetation on site.	Contractor	Following completion of construction activities in an area
Where disturbed areas are not to be used during the operation of the proposed power line and on-site substation, these areas must be rehabilitated/re-vegetated with appropriate natural indigenous vegetation and/or local seed mix. Re-use of native/indigenous plant species removed from disturbance areas in the rehabilitation phase to be determined by a botanist, as applicable. No exotic plants must be used for rehabilitation purposes.	Contractor in consultation with rehabilitation specialist	Following completion of construction activities in an area
Disturbed areas containing no infrastructure and hard surfaces must be rehabilitated with natural vegetation as soon as possible to avoid the potential of erosion and invasion with alien plants. The area should be monitored (responsibility of EO) on a weekly basis throughout the construction phase and on a monthly basis thereafter and to the point where the area has rehabilitated to a satisfactory level.	Contractor in consultation with rehabilitation specialist	Following completion of construction activities in an area
Re-vegetated areas may need to be protected from wind erosion and maintained until an acceptable plant cover has been achieved.	Proponent in consultation with rehabilitation specialist	Post-rehabilitation
Erosion control measures should be used in sensitive areas such as areas with steep slopes.	Proponent in consultation with EO and rehabilitation specialist (if required)	Post-rehabilitation
On-going alien plant monitoring and removal must be undertaken on all areas of natural vegetation on an annual basis.	Proponent	Post-rehabilitation
Weeding:	Contractor/ Developer	Construction/ Operation

Mitigation: Action/Control	Responsibility		Timeframe
It can be anticipated that invasive species and weeds will germinate on rehabilitated soils; these need to be hand-pulled before they are fully established and/or reaching a mature stage where they can regenerate. Where invasive shrubs re-grow, they will have to be eradicated according to the Working for Water specifications			
A site rehabilitation programme should be implemented and this will be developed in collaboration with specialists following completion of construction	Contractor consultation Specialist	in with	Duration of contract

Performance Indicator	<ul style="list-style-type: none"> » All portions of the site, including construction equipment camp and working areas, cleared of equipment and temporary facilities. » Topsoil replaced on all areas and stabilised where practicable or required after construction and temporally utilised areas. » Disturbed areas rehabilitated and acceptable plant cover achieved on rehabilitated sites. » Completed site free of erosion and alien invasive plants.
Monitoring	<ul style="list-style-type: none"> » On-going inspection of rehabilitated areas in order to determine effectiveness of rehabilitation measures implemented during the operational lifespan of the facility. » On-going alien plant monitoring and removal should be undertaken on an annual basis.

CHAPTER 8: OPERATION MANAGEMENT PROGRAMME

Overall Goal: To ensure that the operation of the PV facility does not have unforeseen impacts on the environment and to ensure that all impacts are monitored and the necessary corrective action taken in all cases. In order to address this goal, it is necessary to operate the facility in a way that:

- » Ensures that operation activities are properly managed in respect of environmental aspects and impacts.
- » Enables the operation activities to be undertaken without significant disruption to other land uses in the area, in particular with regard to farming practices, traffic and road use, and effects on local residents.
- » Minimises impacts on fauna using the site.
- » Establish an environmental baseline for solar energy sites in South Africa.

An environmental manager must be appointed during operation whose duty it will be to ensure the implementation of the operational EMPr.

8.1. Objectives

In order to meet this goal, the following objectives have been identified, together with necessary actions and monitoring requirements.

OBJECTIVE 1: Establish clear reporting, communication, and responsibilities in relation to overall implementation of the EMPr during operation

Formal responsibilities are necessary to ensure that key procedures are executed. Specific responsibilities of the Operations Manager, and Environmental Manager for the operation phase of this project are detailed below.

The **Operations Manager** will:

- » Ensure that adequate resources (human, financial, technology) are made available and appropriately managed for the successful implementation of the operational EMPr.
- » Conduct annual basis reviews of the EMPr to evaluate its effectiveness.
- » Take appropriate action as a result of findings and recommendations in management reviews and audits.
- » Provide forums to communicate matters regarding environmental management.

The **Technical/SHEQ Manager** will:

- » Develop and Implement an Environmental Management System (EMS) for the PV facility and associated infrastructure.
- » Manage and report on the facility's environmental performance.
- » Maintain a register of all known environmental impacts and manage the monitoring thereof.
- » Conduct internal environmental audits and co-ordinate external environmental audits.
- » Liaise with statutory bodies such as the National and Provincial Department of Environment, Forestry and Fisheries (DEFF) on environmental performance and other issues.

- » Conduct environmental training and awareness for the employees who operate and maintain the PV facility.
- » Compile environmental policies and procedures.
- » Liaise with interested and affected parties on environmental issues of common concern.
- » Track and control the lodging of any complaints regarding environmental matters.

The Technical/SHEQ Manager must provide fourteen (14) days written notification to the DEFF that the operation phase will commence.

OBJECTIVE 2: Protection of indigenous natural vegetation, fauna and maintenance of rehabilitation

Indirect impacts on vegetation and terrestrial fauna during operation could result from maintenance activities and the movement of people and vehicles on site. In order to ensure the long-term environmental integrity of the site following construction, maintenance of the areas rehabilitated post-construction must be undertaken until these areas have successfully re-established.

It may be necessary to routinely trim vegetation growing between the PV panel rows and/or the plant screens planted along the development site fencing. This is to avoid shading of the panels and reduce fire risks.

Project Component/s	<ul style="list-style-type: none"> » Rehabilitated areas. » Areas along the perimeter fence. » Areas between PV panels. » Topsoil stockpile areas. » Power line. » <u>BESS</u>.
Potential Impact	<ul style="list-style-type: none"> » Disturbance to or loss of vegetation and/or habitat. » Environmental integrity of the site undermined resulting in reduced visual aesthetics, erosion, compromised land capability and the requirement for on-going management intervention.
Activities/Risk Sources	<ul style="list-style-type: none"> » Movement of employee vehicles within and around the site.
Mitigation: Target/Objective	<ul style="list-style-type: none"> » Maintain minimised footprints of disturbance of vegetation/habitats on-site. » Ensure and encourage plant regrowth in non-operational areas of post-construction rehabilitation.

Mitigation: Action/Control	Responsibility	Timeframe
Rehabilitate disturbed areas should the previous attempt be unsuccessful.	O&M Contractor	Operation
Any vegetation clearing that needs to take place as part of the maintenance activities must be done in an environmentally friendly manner, including avoiding the use of herbicides and using manual clearing methods wherever possible.	Contractor	Operation and maintenance
Vehicle movements must be restricted to designated access roads.	O&M Contractor	Operation

Mitigation: Action/Control	Responsibility	Timeframe
Existing roads must be maintained to ensure limited erosion and impact on areas adjacent to roadways.	O&M Contractor	Operation
Maintain erosion control measures implemented during the construction phase (i.e. run-off attenuation on slopes (bags, logs), silt fences, storm water catch-pits, and shade nets).	O&M Contractor	Operation
Develop and implement an appropriate stormwater management plan for the operation phase of the power line and on-site substation.	O&M Contractor	Operation
Site access should be controlled and only authorised staff and contractors should be allowed on-site.	O&M Contractor	Operation
Notice boards stating that fauna and flora may not be collected, harvested etc. should be placed at the entrances to the site.	O&M Contractor	Operation
Any maintenance activities should avoid listed plant species and strive to keep the footprint as low as possible.	O&M Contractor	Operation
No herbicides should be used and if vegetation clearing needs to take place, this should be done by hand.	O&M Contractor	Operation
An on-going alien plant monitoring and eradication programme must be implemented, where necessary.	O&M Contractor	Operation
The collection, hunting or harvesting of any plants or animals at the site should be strictly forbidden.	O&M Contractor	Operation
A botanist and/or ecologist familiar with the vegetation of the area should monitor the rehabilitation success and alien plant removal on an annual basis. The monitoring should be undertaken until the rehabilitation is considered adequate and sufficient.	The developer and Specialist	Annual monitoring until successful re-establishment of vegetation in an area
All hazardous materials should be stored in the appropriate manner to prevent contamination of the site. Any accidental chemical, fuel and oil spills that occur at the site should be cleaned up in the appropriate manner as related to the nature of the spill.	O&M Contractor	Operation
Spill kits must be kept on-site.	O&M Contractor	Operation
A botanist familiar with the vegetation of the area should monitor the rehabilitation success and alien plant removal on an annual basis.	Developer in consultation with Specialist	Annual monitoring until successful re-establishment of vegetation in an area
A faunal/ avifauna incident register must be maintained on site.	O&M Contractor SHEQ Manager	Operation
Implement an animal removal plan to ensure safety of workers and fauna.	O&M Contractor	Operation
Regular monitoring for erosion post-construction to ensure that no erosion problems have developed as a result of the past disturbance.	O&M Contractor	Operation
All declared alien species must be identified and managed in accordance with the Conservation of Agricultural Resources Act, 1983 (Act No. 43 of 1983). There must be an alien species monitoring and eradication program to prevent encroachment of these problem plants for the duration of the	O&M Contractor	Operation

Mitigation: Action/Control	Responsibility	Timeframe
operation. The eradication and monitoring program must aim to address alien plant problems within the whole site, not just the development footprint.		
A rehabilitation strategy for alien plant species must be implemented after construction is completed until the desired outcome is reached.	O&M Contractor	Operation
Regular monitoring must be undertaken for alien plant invasion, which is likely to occur in previously disturbed areas or in areas receiving runoff from the hardened surfaces of the infrastructure.	O&M Contractor	Operation
The washing of panels during maintenance must be done with biodegradable soaps to avoid soil contamination and the poisoning of small animals.	O&M Contractor	Operation
Any potentially dangerous fauna such as snakes or fauna threatened by the maintenance and operational activities must be removed to a safe location.	O&M Contractor	Operation

Performance Indicator	<ul style="list-style-type: none"> » Acceptable level of soil erosion around site, as determined by the site manager. » Acceptable level of increased siltation in washes, as determined by the site manager. » No further disturbance to vegetation or terrestrial faunal habitats. » Continued improvement of rehabilitation efforts.
Monitoring	<ul style="list-style-type: none"> » Observation of vegetation on-site by the facility manager and environmental manager. » Regular inspections to monitor plant regrowth/performance of rehabilitation efforts and weed infestation compared to natural/undisturbed areas. » Inspections of the site on a bi-annual basis. » Water management plan.

OBJECTIVE 3: Protection of avifauna from collision and electrocution

During the operation, the threat of collision with the existing Eskom power lines, as well as proposed 88/132kV power line, is the biggest potential threat to avifauna, particularly sensitive, collision prone species that may occur in the study area. The threat of electrocution while perching on the power line and associated infrastructure serves as a threat to certain sensitive species, depending on the power line structures implemented.

Project Component/s	<ul style="list-style-type: none"> » Power line. » <u>BESS and associated cabling.</u>
Potential Impact	» Collision and electrocution events with the power line.
Activities/Risk Sources	» Operation of the power line without appropriate mitigation measures.
Mitigation: Target/Objective	» Maintain a low number of collision, and electrocution events.

Mitigation: Action/Control	Responsibility	Timeframe
Post-construction surveys during operation with a minimum of 2 surveys of 3 days in extent during a six month period (including	Avifauna Specialist	Operation

Mitigation: Action/Control	Responsibility	Timeframe
the peak wet season) must be undertaken. The surveys aim to obtain mortality data from birds colliding with the panels to advise on appropriate mitigation measures to be implemented to reduce potential bird mortalities. The surveys should be conducted in a regular and systematic manner by means of direct observations and carcass searches. A management programme must be compiled to assess the efficacy of applied mitigation measures and consult or change measures to reduce on-going mortalities when detected. Additional mitigation measures must be tested or applied, especially if mortalities include birds of prey and species of conservation concern.		
The post-construction monitoring must quantify mortalities (especially vulture mortalities) caused by the power line network. The information could then be used to inform the electrical infrastructure mortality incident register. Monitoring must be implemented once a month for at least one year. All searches should be done on foot. A management programme must be compiled to assess the efficacy of applied mitigation measures and consult or change measures to reduce on-going mortalities when detected. Additional mitigation measures must be tested or applied, especially if mortalities include birds of prey and species of conservation concern.	Avifauna Specialist	Operation
Any electrocution and collision events that occur should be recorded, including the species affected and the date. If repeated collisions occur within the same area, then further mitigation and avoidance measures may need to be implemented.	O&M Contractor	Operation
Bird nests must be removed when nest-building attempts are noticed.	O&M Contractor	Operation
Reduce or minimise the use of outdoor lighting to avoid attracting birds to the lights or to reduce potential disorientation to migrating birds.	O&M Contractor	Operation
Report avifauna mortalities (number locality and species) to the Electrical Energy Mortality Register at the Endangered Wildlife Trust.	O&M Contractor	Operation
<u>Any above-ground cables connecting the BESS with the on-site facility substation should be covered with insulation throughout the operation phase to prevent the risk of potential electrocutions should any large bird species interact in any manner with the BESS.</u>	<u>O&M Contractor</u>	<u>Operation</u>

Performance Indicator	<ul style="list-style-type: none"> » Minimal collision, or electrocution events. » Reduced statistical detection/observation of bird mortalities.
Monitoring	<ul style="list-style-type: none"> » Observation of electrocution or collision events with the power line. » Monitor power line servitude for mortalities.

OBJECTIVE 4: Minimise soil degradation, erosion and alien plant invasion

The soil on site may be impacted in terms of:

- » *Soil degradation including erosion* - by wind and water and subsequent deposition elsewhere is of a concern across the entire site.
- » *Uncontrolled run-off* - relating to construction activity (excessive wetting, uncontrolled discharge, etc.) will also lead to accelerated erosion and possible sedimentation of drainage systems outside of the project site during operation.
- » *Degradation* - of the natural soil profile due to pollution.

Project Component/s	<ul style="list-style-type: none"> » Underground cabling. » Ancillary buildings. » Access roads. » Power line. » <u>BESS and associated cabling.</u>
Potential Impact	<ul style="list-style-type: none"> » Soil degradation. » Soil erosion. » Increased deposition of soil into drainage systems. » Increased run-off over the site.
Activities/Risk Sources	<ul style="list-style-type: none"> » Poor rehabilitation of cleared areas. » Rainfall - water erosion of disturbed areas. » Wind erosion of disturbed areas. » Concentrated discharge of water from construction activity.
Mitigation: Target/Objective	<ul style="list-style-type: none"> » Ensure rehabilitation of disturbed areas is maintained. » Minimise soil degradation (i.e. wetting). » Minimise soil erosion. » Ensure continued stability of embankments/excavations.

Mitigation: Action/Control	Responsibility	Timeframe
Ensure dust control on site through wetting of denuded areas or the use of an appropriate dust suppression measure.	O&M Contractor	Operation
Maintain erosion control measures implemented during the construction phase (i.e. run-off attenuation on slopes (sand bags, logs), silt fences, storm water catch-pits, and shade nets).	O&M Contractor	Operation
Control depth of excavations and stability of cut faces/sidewalls.	O&M Contractor	Operation
Regular monitoring by the operation and maintenance team for alien plants at the site should occur and could be conducted simultaneously with erosion monitoring.	O&M Contractor	Operation

Performance Indicator	<ul style="list-style-type: none"> » Acceptable level of soil erosion around the site, as determined by the site manager. » Minimal issues related to alien plant invasion
Monitoring	<ul style="list-style-type: none"> » Inspections of the site on a bi-annual basis. » Water management plan developed and implemented.

OBJECTIVE 5: Minimise dust and air emissions

During the operation phase, limited gaseous or particulate emissions are anticipated from exhaust emissions (i.e. from operational vehicles). Windy conditions and the movement of vehicles on site may lead to dust creation.

Project Component/s	<ul style="list-style-type: none"> » Hard engineered surfaces. » On-site vehicles.
Potential Impact	<ul style="list-style-type: none"> » Dust and particulates from vehicle movement to and on-site. » Release of minor amounts of air pollutants (for example NO₂, CO and SO₂) from vehicles.
Activities/Risk Sources	<ul style="list-style-type: none"> » Re-entrainment of deposited dust by vehicle movements. » Wind erosion from unsealed roads and surfaces. » Fuel burning vehicle and construction engines.
Mitigation: Target/Objective	<ul style="list-style-type: none"> » To ensure emissions from all vehicles are minimised, where possible. » To minimise nuisance to the community from dust emissions and to comply with workplace health and safety requirements.

Mitigation: Action/Control	Responsibility	Timeframe
Roads must be maintained that will ensure that nuisance to the community from dust is not visibly excessive.	O&M Contractor	Operation
Appropriate dust suppression must be applied to the roads as required to minimise/control airborne dust.	O&M Contractor	Operation
Speed of vehicles must be restricted on site, as defined by the Environmental Manager.	O&M Contractor	Operation
Vehicles and equipment must be maintained in a road-worthy condition at all times.	O&M Contractor	Operation

Performance Indicator	<ul style="list-style-type: none"> » No complaints from affected residents or community regarding dust or vehicle emissions. » Dust suppression measures implemented where required. » Drivers made aware of the potential safety issues and enforcement of strict speed limits when they are employed.
Monitoring	<ul style="list-style-type: none"> » Immediate reporting by personnel of any potential or actual issues with nuisance, dust or emissions to the Site Manager. » A complaints register must be maintained, in which any complaints from residents/the community will be logged, and thereafter complaints will be investigated and, where appropriate, acted upon. » An incident reporting system must be used to record non-conformances to the EMPr.

OBJECTIVE 6: Ensure appropriate operation and maintenance of the battery energy storage system

<u>Project Component/s</u>	» <u>Battery Energy Storage System.</u>
<u>Potential Impact</u>	» <u>Fire and safety risks</u> » <u>Leakages and impacts on soils and water resources.</u>
<u>Activities/Risk Sources</u>	» <u>Inappropriate operation and maintenance of BESS.</u>
<u>Mitigation: Target/Objective</u>	» <u>To avoid and or minimise the potential risk of associated with the operation and maintenance of the BESS.</u>

<u>Mitigation: Action/Control</u>	<u>Responsibility</u>	<u>Timeframe</u>
<u>Compile (and adhere to) a procedure for the safe handling of battery cells.</u>	<u>O&M Contractor</u>	<u>Operation</u>
<u>Ensure that battery supplier user guides, safety specifications and MSDS are filed on site at all times.</u>	<u>O&M Contractor</u>	<u>Operation</u>
<u>Operate, maintain and monitor the BESS as per supplier specifications.</u>	<u>O&M Contractor</u>	<u>Operation</u>
<u>Compile method statements for approval by the Technical/SHEQ Manager for battery cell, electrolyte and battery cell/ container replacement. Maintain method statements on site.</u>	<u>O&M Contractor</u>	<u>Operation</u>
<u>Ensure that all maintenance contractors/ staff are familiar with the supplier's specifications.</u>	<u>O&M Contractor</u>	<u>Operation</u>
<u>Provide signage on site specifying the types of batteries in use and the risk of exposure to hazardous material and electric shock.</u>	<u>O&M Contractor</u>	<u>Operation</u>
<u>Provide signage on site specifying how electrical and chemical fires should be dealt with by first responders, and the potential risks to first responders (e.g. toxic fumes). Provide suitable firefighting equipment on site.</u>	<u>O&M Contractor</u>	<u>Operation</u>
<u>Maintain strict access control to the battery storage area.</u>	<u>O&M Contractor</u>	<u>Operation</u>
<u>Undertake regular visual checks on BESS equipment to identify signs of damage or leaks.</u>	<u>O&M Contractor</u>	<u>Operation</u>
<u>Provide environmental awareness training to all personnel on site. Training should include discussion of:</u> <ul style="list-style-type: none"> o <u>Potential impact of electrolyte spills on groundwater;</u> o <u>Suitable disposal of waste and effluent;</u> o <u>Key measures in the EMP relevant to worker's activities;</u> o <u>How incidents and suggestions for improvement can be reported.</u> <u>Ensure that all attendees remain for the duration of the training and on completion sign an attendance register that clearly indicates participants' names.</u>	<u>O&M Contractor</u>	<u>Operation</u>
<u>Batteries must strictly be maintained by the supplier or suitably qualified persons for the duration of the project life cycle. No unauthorised personnel should be allowed to maintain the BESS.</u>	<u>O&M Contractor</u>	<u>Operation</u>

Mitigation: Action/Control	Responsibility	Timeframe
<u>Damaged and used batteries must be removed from site by the supplier or any other suitably qualified professional for recycling or appropriate disposal.</u>	O&M Contractor	Operation

Performance Indicator	<ul style="list-style-type: none"> » <u>BESS operated and maintained in accordance with supplier specifications.</u> » <u>Appropriate signage on site.</u> » <u>Employees appropriately trained.</u> » <u>Required documentation available on site.</u> » <u>Firefighting equipment and training provided before the operation phase commences.</u> » <u>Damaged and used batteries are removed from site by the supplier or any other suitably qualified professional for recycling or appropriate disposal. Records of batteries taken from site are kept on file by the personnel on site.</u>
Monitoring	<ul style="list-style-type: none"> » <u>The O&M contractor must monitor indicators listed above to ensure that they have been met.</u>

OBJECTIVE 7: Ensure the implementation of an appropriate fire management plan and general management measures during the operation phase

The following recommendations below must be considered with regards to fire protection on site:

- » Alien Invasive species should be completely eradicated in order to decrease the fire risk associated with the site.
- » Cigarette butts may not be thrown in the veld, but must be disposed of correctly. Designated smoking areas must be established with suitable receptacles for disposal.
- » In case of a fire outbreak, contact details of the local fire and emergency services must be readily available.
- » Contractors must ensure that basic firefighting equipment is available on site as per the specifications defined by the health and safety representative / consultant.
- » The fire risk on site is a point of discussion that must take place as part of the environmental induction training prior to commencement of construction.
- » The contractor must also comply with the requirements of the Occupational Health and Safety Act with regards to fire protection.

The following below can be used as a guide for appropriate fire management (also refer to **Appendix I**):

Project Component/s	» Operation and maintenance of the PV facility and associated infrastructure, <u>including the BESS.</u>
Potential Impact	» Veld fires can pose a personal safety risk to local farmers and communities, and their homes, crops, livestock and farm infrastructure, such as gates and fences. In addition, fire can pose a risk to the PV facility infrastructure <u>and BESS infrastructure.</u>
Activities/Risk Sources	» The presence of operation and maintenance personnel and their activities on the site can increase the risk of veld fires.
Mitigation: Target/Objective	» To avoid and or minimise the potential risk of veld fires on local communities and their livelihoods.

Mitigation: Action/Control	Responsibility	Timeframe
Provide adequate firefighting equipment on site and establish a fire-fighting management plan during operation (refer to Appendix I).	O&M Contractor	Operation
Provide fire-fighting training to selected operation and maintenance staff.	O&M Contractor	Operation
Ensure that appropriate communication channels are established to be implemented in the event of a fire.	O&M Contractor	Operation
Fire breaks should be established where and when required. Cognisance must be taken of the relevant legislation when planning and burning firebreaks (in terms of timing, etc.).	Contractor	Operation
Upon completion of the construction phase, an emergency evacuation plan must be drawn up to ensure the safety of the staff and surrounding land users in the case of an emergency.	O&M Contractor	Operation
Contact details of emergency services should be prominently displayed on site.	O&M Contractor	Operation
Road borders must be regularly maintained to ensure that vegetation remains short and that they therefore serve as an effective firebreak.	O&M Contractor	Operation
Staff and general trips to the site should occur outside of peak traffic periods.	O&M Contractor	Operation
Should panels be required to be replaced, the following will apply: <ul style="list-style-type: none"> » Materials and panels are to be stored within the previously disturbed construction laydown area. No disturbance of areas outside of these areas should occur. » Full clean-up of all materials must be undertaken after the removal and replacement of the solar panel arrays and associated infrastructure is complete, and disturbed areas appropriately rehabilitated. » Most of the materials used for solar panel systems can be recycled. The majority of the glass and semiconductor materials can be recovered and re-used or recycled. Recyclable materials must be transported off-site by truck and managed at appropriate facilities in accordance with relevant waste management regulations. No waste materials may be left on-site. » Waste material which cannot be recycled shall be disposed of at an appropriately licensed waste disposal site or as required by the relevant legislation. 	O&M Contractor	Operation

Performance Indicator	<ul style="list-style-type: none"> » Firefighting equipment and training provided before the operation phase commences. » Appropriate fire breaks in place.
Monitoring	<ul style="list-style-type: none"> » The O&M operator must monitor indicators listed above to ensure that they have been met.

OBJECTIVE 8: Minimise the potential impact on farming activities and on the surrounding landowners

Once operational, the impact on the daily living and movement patterns of neighbouring residents is expected to be minimal and intermittent (i.e. the increase in traffic to and from site, possible dust creation of vehicle movement on gravel roads on site and possible increase in criminal activities). The number of workers on site is anticipated to have minimal negative social impacts in this regard.

The operations at the PV facility is not anticipated to have severe negative impacts on the neighbouring farmers' living and movement patterns, apart from a limited increase in the movement of people to and from the site, as well as the presence of these employees on-site on a permanent basis.

Vehicle movement to and from the site (e.g. transportation of workers and goods) could influence road users' daily movement patterns, although it is anticipated that this impact would only materialise intermittently.

Project Component/s	<ul style="list-style-type: none"> » Possible negative impacts of activities undertaken on site on the activities of surrounding property owners. » Impact on farming activities on site.
Potential Impact	<ul style="list-style-type: none"> » Possible limited intrusion impact on surrounding landowners. » Visual impact of facility degradation and vegetation rehabilitation failure.
Activities/Risk Sources	<ul style="list-style-type: none"> » Traffic to and from site could affect daily living and movement patterns of surrounding residents. » Viewing of the facility by observers in a negative light due to degradation and rehabilitation failure.
Mitigation: Target/Objective	<ul style="list-style-type: none"> » Effective management of the facility. » Mitigation of intrusion impacts on property owners. » Mitigation of impact on farming activities. » Well maintained and neat facility.

Mitigation: Action/Control	Responsibility	Timeframe
Effective management of the facility to avoid any environmental pollution focusing on water, waste and sanitation infrastructure and services.	Contractor and Security Contractor	Operation
Vehicle movement to and from the site should be minimised as far as possible.	Contractor and Security Contractor	Operation
Infrastructure such as fencing and/or gates must be maintained in the present condition or repaired if disturbed due to project activities.	O&M Contractor	Operation
Maintain the general appearance of the facility as a whole, including the PV panels, servitudes and the ancillary structures.	O&M Contractor	Operation
Maintain roads and servitudes to forego erosion and to suppress dust.	O&M Contractor	Operation
Monitor rehabilitated areas, and implement remedial action as and when required.	O&M Contractor	Operation

Performance Indicator	<ul style="list-style-type: none"> » No environmental pollution occurs (i.e. waste, water, and sanitation). » No intrusion on private properties and on the activities undertaken on the surrounding properties. » Continuation of farming activities in surrounding areas. » Well maintained and neat facility with intact vegetation on and in the vicinity of the facility.
Monitoring	<ul style="list-style-type: none"> » The O&M operator should be able to demonstrate that the facility is well managed without environmental pollution and that the above requirements have been met. » Monitoring of the entire site on an ongoing basis (by the O&M operator)

OBJECTIVE 9: Appropriate handling and management of hazardous substances, waste and dangerous goods

The operation of the PV facility and the BESS will involve the storage of chemicals and hazardous substances, as well as the generation of limited waste products. The main wastes expected to be generated by the operation activities includes general solid waste, hazardous waste, spent battery components and sewage waste, all of which must be appropriately managed.

Project Component/s	<ul style="list-style-type: none"> » On-site substation. » <u>BESS.</u> » PV facility. » Operation and maintenance staff. » Workshop / control room.
Potential Impact	<ul style="list-style-type: none"> » Inefficient use of resources resulting in excessive waste generation. » Litter or contamination of the site or water through poor waste management practices. » Contamination of water or soil because of poor materials management.
Activity/Risk Source	<ul style="list-style-type: none"> » Substation, transformers, switchgear and supporting equipment. » Workshop / control room.
Mitigation: Target/Objective	<ul style="list-style-type: none"> » Comply with waste management legislation. » Minimise production of waste. » Ensure appropriate waste disposal. » Avoid environmental harm from waste disposal. » Ensure appropriate storage of chemicals and hazardous substances.

Mitigation: Action/Control	Responsibility	Timeframe
<u>Develop a waste management plan, detailing:</u> <ul style="list-style-type: none"> » <u>Expected type and amount of waste;</u> » <u>Measures to reduce waste;</u> » <u>Type of storage for different waste types;</u> » <u>Waste contractors that will collect waste; and</u> » <u>Monitoring procedures to ensure the waste management plan is implemented.</u> 	<u>O&M Contractor</u>	<u>Operation and maintenance</u>
Hazardous substances (such as used/new transformer oils, etc.) must be stored in sealed containers within a clearly demarcated designated area.	O&M Contractor	Operation
Storage areas for hazardous substances must be appropriately sealed and banded.	O&M Contractor	Operation

Mitigation: Action/Control	Responsibility	Timeframe
All structures and/or components replaced during maintenance activities must be appropriately disposed of at an appropriately licensed waste disposal site or sold to a recycling merchant for recycling.	O&M Contractor	Operation
Care must be taken to ensure that spillage of oils and other hazardous substances are limited during maintenance. Handling of these materials should take place within an appropriately sealed and banded area. Should any accidental spillage take place, it must be cleaned up according to specified standards regarding bioremediation.	O&M Contractor	Operation and maintenance
Disposal of waste must be in accordance with relevant legislative requirements, including the use of licensed contractors.	Contractor, The developer / waste management contractor	Operation
Waste handling, collection, and disposal operations must be managed and controlled by a waste management contractor.	Contractor, waste management contractor	Operation
Used oils and chemicals: » Appropriate disposal must be arranged with a licensed facility in consultation with the administering authority » Waste must be stored and handled according to the relevant legislation and regulations	O&M Contractor	Operation
General waste must be recycled where possible or disposed of at an appropriately licensed landfill.	O&M Contractor	Operation
Hazardous waste (including hydrocarbons) and general waste must be stored and disposed of separately.	O&M Contractor	Operation
<u>Develop and adhere to a procedure for the safe handling of battery cells during the undertaking of maintenance activities.</u>	<u>O&M Contractor</u>	<u>Operation</u>
<u>Ensure that service providers dispose of used batteries properly by requesting and retaining receipts for disposal/refurbishment.</u>	<u>O&M Contractor</u>	<u>Operation and maintenance</u>
<u>Ensure signage on all hazardous storage areas indicating as a minimum:</u> » <u>The type (and chemical name/s).</u> » <u>Who to contact (immediately) if a spill or leak is detected.</u> » <u>MSDS sheets (alternatively ensure that these are available on site).</u>	<u>O&M Contractor</u>	<u>Operation and maintenance</u>
<u>Storage areas for hazardous substances must be appropriately sealed and banded.</u>	<u>O&M Contractor</u>	<u>Operation</u>
<u>Spill kits must be made available on-site for the clean-up of spills and leaks of contaminants.</u>	<u>O&M Contractor</u>	<u>Operation and maintenance</u>
<u>All hazardous materials must be stored in the appropriate manner (stored in sealed containers within a clearly demarcated designated area) to prevent contamination of the site. Any accidental chemical, fuel and oil spills that occur at the site should be cleaned up in the appropriate manner as related to the nature of the spill.</u>	<u>O&M Contractor</u>	<u>Operation</u>

Mitigation: Action/Control	Responsibility	Timeframe
<u>Immediately report significant spillages and initiate an environmental site assessment for risk assessment and remediation if necessary.</u>	O&M Contractor	Operation
<u>Emergency response arrangements and systems such as foam pourers, fire-fighting systems and cooperation with emergency responders must be implemented. Preventive measures could include maintenance procedures to prevent the occurrence of a catastrophic loss of containment, as well as strict control of ignition sources and other measures which may be required according to standards such as those prescribed by the South African National Standards system.</u>	O&M Contractor	Operation

Performance Indicator	<ul style="list-style-type: none"> » No complaints received regarding waste on site or indiscriminate dumping. » <u>No complaints received regarding storage of hazardous and dangerous goods on site.</u> » Internal site audits identifying that waste segregation recycling and reuse is occurring appropriately. » Provision of all appropriate waste manifests. » No contamination of soil or water. » <u>Procedure for the safe handling of the batteries during the undertaking of maintenance activities is in place.</u>
Monitoring	<ul style="list-style-type: none"> » Waste collection must be monitored on a regular basis. » Waste documentation must be completed and available for inspection. » <u>Records of accidental spills and clean-up procedures and the results thereof must be audited by the EO & Environmental Manager during the operation phase.</u> » An incidents/complaints register must be maintained, in which any complaints from the community must be logged. » Complaints must be investigated and, if appropriate, acted upon. » Regular reports on exact quantities of all waste streams exiting the site must be compiled by the waste management contractor and monitored by the O&M operator. » All appropriate waste disposal certificates accompany the monthly reports.

OBJECTIVE 10: Enhancement of positive social impacts and mitigation of negative social impacts

During the operation phase of Lichtenburg 2, both positive and negative impacts are expected to occur. Positive impacts can be enhanced through the application of enhancement measures and negative impacts can be mitigated and the significance reduced through the application of mitigation measures.

Project Component/s	» Operational PV facility
Potential Impact	» Loss of opportunities to stimulate production and employment of the local economy
Activity/Risk Source	» Labour practices employed during operation
Mitigation: Target/Objective	» Maximise local community employment benefits in the local economy

Mitigation: Action/Control	Responsibility	Timeframe
Adopt a local employment policy to maximise the opportunities made available to the local labour force.	O&M operator	Operation
Establish vocational training programs for the local labour force to promote the development of skills	O&M operator	Operation

Performance Indicator	<ul style="list-style-type: none"> » Percentage of workers that were employed from local communities » Number of people attending vocational training on an annual basis
Monitoring	<ul style="list-style-type: none"> » The O&M operator must keep a record of local recruitments and information on local labour for reporting purposes

CHAPTER 9: MANAGEMENT PROGRAMME: DECOMMISSIONING

The PV facility is expected to have a lifespan of 25 - 30 years (i.e. with routine maintenance). The infrastructure would only be decommissioned and rehabilitated once it has reached the end of its economic life. It is most likely that decommissioning activities of the infrastructure of the PV facility considered in the EIA process would comprise the disassembly and replacement of the individual components with more appropriate technology/infrastructure available at that time.

The relevant mitigation measures contained under the construction section should be applied during decommissioning and therefore are not repeated in this section.

» **Site Preparation**

Site preparation activities will include confirming the integrity of the access to the site to accommodate required equipment, preparation of the site (e.g. lay down areas, construction platform) and the mobilisation of construction equipment.

» **Disassemble and Remove Infrastructure**

Disassembled components will be reused, recycled, or disposed of in accordance with regulatory requirements.

9.1. Objectives

Within a period of at least 12 months prior to the decommissioning of the site, a Decommissioning Method Statement must be prepared and submitted to the Local Planning Authority, as well as the Provincial and National Environmental Authority. This method statement must cover site restoration, soil replacement, landscaping, conservation, and a timeframe for implementation. Furthermore, this decommissioning must comply with all relevant legal requirements administered by any relevant and competent authority at that time.

The objectives of the decommissioning phase of the proposed project are to:

- » Follow a process of decommissioning that is progressive and integrated into the short- and long-term project plans that will assess the closure impacts proactively at regular intervals throughout project life.
- » Implement progressive rehabilitation measures, beginning during the construction phase.
- » Leave a safe and stable environment for both humans and animals and make their condition sustainable.
- » Return rehabilitated land-use to a standard that can be useful to the post-project land user.
- » Where applicable, prevent any further soil and surface water contamination by maintaining suitable storm water management systems.
- » Maintain and monitor all rehabilitated areas following re-vegetation, and if monitoring shows that the objectives have been met, apply for closure.

9.2. Approach to the Decommissioning Phase

It is recommended that planning of the decommissioning of the project and rehabilitation of the site should take place well in advance (at least two years) of the planned decommissioning activities. Important factors that need to be taken into consideration are detailed below.

Two possible scenarios for this decommissioning phase are detailed below:

SCENARIO 1: TOTAL DECOMMISSIONING OF PV FACILITY.

If the decision is taken at the end of the project lifespan to totally decommission the facility, i.e. make the land available for an alternative land use, the following should take place:

- » All concrete and imported foreign material must be removed from the PV facility i.e. panels, support structures, battery units etc.;
- » The holes where the panel support structures are removed must be levelled and covered with subsoil and topsoil;
- » Infrastructure not required for the post-decommissioning use of the site must be removed;
- » Access roads and servitudes not required for the post-decommissioning use of the site must be rehabilitated. If necessary, an ecologist should be consulted to give input into rehabilitation specifications;
- » Tracks that are to be utilised for the future land use operations should be left *in-situ*. The remainder of the tracks to be removed (ripped) and topsoil replaced;
- » All ancillary buildings and access points are to be removed unless they can be used for the future land use;
- » The underground electric cables are to be removed if they cannot be used in the future land use;
- » All material (cables, PV Panels etc.) must be re-used or recycled wherever possible;
- » Battery units must be removed from site by the supplier or accredited service provider for recycling or appropriate disposal.
- » The competent authority may grant approval to the owner not to remove the landscaping and underground foundations;
- » The site must be seeded with locally sourced indigenous vegetation to allow revegetation of the site; and
- » Monitor rehabilitated areas quarterly for at least a year following decommissioning, and implement remedial action as and when required.

SCENARIO 2: PARTIAL DECOMMISSIONING OF ENERGY FACILITY.

Should more advanced technology become available it may be decided to continue to use the site as a PV facility. Much of the existing infrastructure is likely to be re-used in the upgraded facility. In this case, all infrastructure that will no longer be required for the upgraded facility must be removed as described for scenario 1. The remainder of the infrastructure should remain in place or upgraded depending on the requirements of the new facility. Any upgrades to the facility at this stage must comply with relevant legislation.

9.2.1. Identification of structures for post-closure use

Access roads should be assessed in conjunction with the future land users to determine if these could be used. Where not required, these access roads should be decommissioned and rehabilitated.

9.2.2. Removal of infrastructure

All infrastructure must be dismantled and removed. Inert material must be removed from site and disposed of at a suitably registered landfill site. The PV facility and BESS components must be removed and recycled where possible or disposed of at a suitably registered landfill site. All foundations must be removed to a depth of 1m. Hard surfaces must be ripped to a depth of 1m and vegetated.

9.2.3. Soil rehabilitation

The steps that should be taken during the rehabilitation of soils are as follows:

- » The deposited soils must be ripped to ensure reduced compaction;
- » An acceptable seed bed should be produced by surface tillage;
- » Restore soil fertility;
- » Incorporate the immobile fertilisers in to the plant rooting zone before ripping; and
- » Apply maintenance dressing of fertilisers on an annual basis until the soil fertility cycle has been restored.

9.2.4. Establishment of vegetation

The objective is to restore the project site to a self-sustaining cycle, i.e. to realise the re-establishment of the natural nutrient cycle with ecological succession initiated.

The objectives for the re-vegetation of reshaped and top-soiled land are to:

- » Prevent erosion;
- » Restore the land to the agreed land capability;
- » Re-establish eco-system processes to ensure that a sustainable land use can be established without requiring fertilizer additions; and
- » Restore the biodiversity of the area as far as possible.

9.2.5. Maintenance

Established vegetation requires regular maintenance. If the growth medium consists of low-fertility soils, then regular maintenance will be required until the natural fertility cycle has been restored.

9.2.6. Monitoring

The purpose of monitoring is to ensure that the objectives of rehabilitation are met and that the rehabilitation process is followed. The physical aspects of rehabilitation should be carefully monitored during the progress of establishment of desired final ecosystems.

The following items should be monitored continuously:

- » Erosion status;
- » Vegetation species diversity; and
- » Faunal re-colonisation.

**Appendix A:
Layout and Sensitivity Maps**

26°6'15"E

26°7'20"E

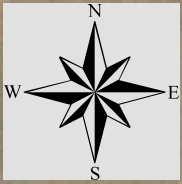

26°2'50"S

26°2'50"S

26°3'55"S

26°3'55"S

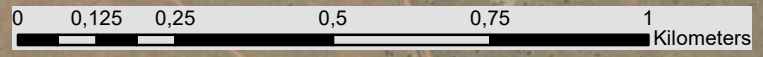

26°6'15"E

26°7'20"E

Lichtenburg 2

Detailed Layout Map of the Development Footprint and Battery Energy Storage System

Legend

- Existing Power line
- Regional Road
- Farm Portion
- Lichtenburg 2 (project site)
- Project Development Site

Detailed Layout Plan:

- Existing Access Road
- ⋯ Laydown Area & Proposed BESS
- Internal Access Road
- ▨ Power line corridor
- Solar Panel
- On-site Substation
- Security Building and O&M Block

Scale: 1:12 000
 Projection: LO27_WGS 1984
 Map Ref.: Lichtenburg PV_L2 Detailed Layout (Preferred)_11.12.18



Lichtenburg 2

Environmental Sensitivity and Amended Layout Map

26°6'15"E

26°7'20"E



26°2'50"S

26°2'50"S

26°3'55"S

26°3'55"S

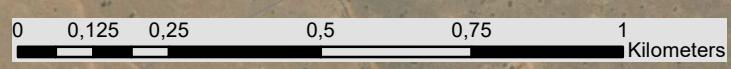

26°6'15"E

26°7'20"E

Legend

- Regional Road
- Existing Power line
- Farm Portion
- Lichtenburg 2 (project site)

Detailed Layout Plan:

- Existing Access Road
- Laydown Area & Proposed BESS
- Internal Access Road
- Power line corridor
- Solar Panels
- On-site Substation
- Security Building and O&M Block

Sensitive Environmental Features:

- Vachelia (Acacia) erioloba (No-Go Ecological Area)
- Palaeontological Observations
- Livestock watering point and power line servitude (Moderately High Avifauna Sensitivity - development allowed)
- Open dolomite grassland/bush clump mosaics (Moderately High Avifauna Sensitivity - development allowed)
- Open dolomite grassland/ bush clump mosaics, power line servitude and wet/moist grassland (Medium Avifauna Sensitivity)
- Savanna Grassland (Medium Ecological Sensitivity)
- Palaeo-Drainage Grassland (Medium Ecological Sensitivity)

Scale:
 Projection: 215007_WGS 1984
 Map Ref.: Lichtenburg PV_L2 Env Sens & Dev. Foot 30.09.2020



Appendix B:
Grievance Mechanism for Public Complaints and Issues

GRIEVANCE MECHANISM / PROCESS

PURPOSE

This Grievance Mechanism has been developed to receive and facilitate the resolution of concerns and grievances regarding the project's environmental and social performance¹. The aim of the grievance mechanism is to ensure that grievances or concerns are raised by stakeholders and to ensure such grievances are addressed in a manner that:

- » Provides a predictable, accessible, transparent, and credible process to all parties, resulting in outcomes that are fair and equitable, accountable and efficient.
- » Promotes trust as an integral component of broader community relations activities.
- » Enables more systematic identification of emerging issues and trends, facilitating corrective action and pre-emptive engagement.

The aim of this Grievance Mechanism is to address grievances in a manner that does not require a potentially costly and time-consuming legal process.

PROCEDURE FOR RECEIVING AND RESOLVING GRIEVANCES

The following proposed grievance procedures are to be complied with throughout the construction, operation and decommissioning phases of the project:

- » Local landowners, communities and authorities must be informed in writing by the Developer of the grievance mechanism and the process by which grievances can be brought to the attention of the Developer through its designated representative. This must be undertaken with the commencement of the construction phase.
- » A company representative must be appointed as the contact person in order for grievances to be addressed. The name and contact details of the contact person must be provided to local landowners, communities and authorities when requested.
- » Project related grievances relating to the construction, operation and or decommissioning phases must be addressed in writing to the contact person. The contact person should assist local landowners and or communities who may lack resources to submit/prepare written grievances, by recording grievances and completing written grievance notices where applicable, translating requests or concerns or by facilitating contact with the nominated contact person. The following information should be obtained, as far as possible, regarding each written grievance, which may act as both acknowledgement of receipt as well as record of grievance received:
 - a. The name and contact details of the complainant;
 - b. The nature of the grievance;
 - c. Date raised, received, and for which the meeting was arranged;
 - d. Persons elected to attend the meeting (which will depend on the grievance); and
 - e. A clear statement that the grievance procedure is, in itself, not a legal process. Should such avenues be desired, they must be conducted in a separate process and do not form part of this grievance mechanism.

¹ This grievance mechanism is a guideline of the requirements that must be implemented, but is subject to amendment prior to the start of the construction phase.

- » The grievance must be registered with the contact person who, within 2 working days of receipt of the grievance, must contact the Complainant to discuss the grievance and, if required, agree on suitable date and venue for a meeting in order to discuss the grievances raised. Unless otherwise agreed, the meeting should be held within 2 weeks of receipt of the grievance.
- » The contact person must draft a letter to be sent to the Complainant acknowledging receipt of the grievance, the name and contact details of Complainant, the nature of the grievance, the date that the grievance was raised, and the date and venue for the meeting (once agreed and only if required).
- » A grievance register must be kept on site (in electronic format, so as to facilitate editing and updating), and shall be made available to all parties wishing to gain access thereto.
- » Prior to the meeting being held the contact person must contact the Complainant to discuss and agree on the parties who should attend the meeting, as well as a suitable venue. The people who will be required to attend the meeting will depend on the nature of the grievance. While the Complainant and or Developer are entitled to invite their legal representatives to attend the meeting/s, it should be made clear to all the parties involved in the process that the grievance mechanism process is not a legal process, and that if the Complainant invites legal representatives, the cost will be their responsibility. It is therefore recommended that the involvement of legal representatives be limited as far as possible, as a matter of last resort, and that this process be primarily aimed at stakeholder relationship management as opposed to an arbitration or litigation mechanism
- » The meeting should be chaired by the Developer's representative appointed to address grievances. The Developer must supply and nominate a representative to capture minutes and record the meeting/s.
- » Draft copies of the minutes must be made available to the Complainant and the Developer within 5 working days of the meeting being held. Unless otherwise agreed, comments on the Draft Minutes must be forwarded to the company representative appointed to manage the grievance mechanism within 5 working days of receipt of the draft minutes.
- » The meeting agenda must be primarily the discussion of the grievance, avoidance and mitigation measures available and proposed by all parties, as well as a clear indication of the future actions and responsibilities, in order to put into effect the proposed measures and interventions to successfully resolve the grievance.
- » In the event of the grievance being resolved to the satisfaction of all the parties concerned, the outcome must be recorded and signed off by the relevant parties. The record should provide details of the date of the meeting/s, the names of the people that attended the meeting/s, the outcome of the meeting/s, and where relevant, the measures identified to address the grievance, the party responsible for implementing the required measures, and the agreed upon timeframes for the measures to be implemented.
- » In the event of a dispute between the Complainant and the Developer regarding the grievance, the option of appointing an independent mediator to assist with resolving the issue should be discussed. The record of the meeting/s must note that a dispute has arisen and that the grievance has not been resolved to the satisfaction of all the parties concerned.
- » In the event that the parties agree to appoint a mediator, the Developer will be required to identify three (3) mediators and forward the names and CVs to the Complainant within 2 weeks of the dispute being declared. The Complainant, in consultation with the Developer, must identify the preferred mediator and agree on a date for the next meeting. The cost of the mediator must be borne by the Developer. The Developer must supply and nominate a representative to capture minutes and record the meeting/s.
- » In the event of the grievance, with the assistance of the mediator, being resolved to the satisfaction of all the parties concerned, the outcome must be recorded and signed off by the relevant parties,

including the mediator. The record should provide details on the date of the meeting/s, the names of the people that attended the meeting/s, the outcome of the meeting/s, and where relevant, the measures identified to address the grievance, the party responsible for implementing the required measures, and the agreed upon timeframes for the measures to be implemented.

- » In the event of the dispute not being resolved, the mediator must prepare a draft report that summaries the nature of the grievance and the dispute. The report should include a recommendation by the mediator on the proposed way forward with regard to the addressing the grievance.
- » The draft report must be made available to the Complainant and the Developer for comment before being finalised and signed by all parties, which signature may not be unreasonably withheld by either party. Unless otherwise agreed, comments on the draft report must be forwarded to the company representative appointed to manage the grievance mechanism within 5 working days. The way forward will be informed by the recommendations of the mediator and the nature of the grievance.

A Complaint is closed out when no further action is required, or indeed possible. Closure status must be classified and captured following mediation or successful resolution in the Complaints Register as follows:

- » Resolved. Complaints where a resolution has been agreed and implemented and the Complainant has signed the Confirmation Form.
- » Unresolved. Complaints where it has not been possible to reach an agreed resolution despite mediation.
- » Abandoned. Complaints where the Complainant is not contactable after one month following receipt of a Complaint and efforts to trace his or her whereabouts have been unsuccessful.

The grievance mechanism does not replace the right of an individual, community, group or organization to take legal action should they so wish. In the event of the grievance not being resolved to the satisfaction of Complainant and or the Developer, either party may be entitled to legal action if an appropriate option, however, this grievance mechanisms aims to avoid such interactions by addressing the grievances within a short timeframe, and to mutual satisfaction, where possible.

**Appendix C:
Open Space Management Plan**

OPEN SPACE MANAGEMENT PLAN

1. PURPOSE

The purpose of this Open Space Management Plan is to provide a framework for the integrated management of the natural and semi-natural areas during the construction and operation of Lichtenburg 2. The broad objectives of the plan include the following:

- » Managing and maintaining the ecosystem in a near-natural state and restoring and/or rehabilitating the ecosystems to such a state.
- » Developing and implementing a monitoring and eradication programme for alien and invasive plant species.
- » Promoting the natural re-establishment and/or planting of indigenous species in order to retard erosion and alien plant establishment.

1.1. Access control

- » Access to the facility should be strictly controlled.
- » All visitors and contractors should be required to sign-in.
- » Signage at the entrance should indicate that disturbance to fauna and flora is strictly prohibited.
- » Induction and/or training material used for new staff and visitors must include a map and discussion regarding the footprint of the facility, and which areas are deemed off-limits.

1.2. Prohibited activities

The following activities should not be permitted by anyone except the landowner or his representatives:

- » No fires within the site.
- » No hunting, collecting, trading or disturbing of fauna and flora, except where required for the safe construction and operation of the PV facility and only by the Environmental Control Officer on duty with the appropriate permits and landowner permission.
- » No unnecessary driving off of demarcated roads.
- » No interfering with livestock.
- » No use of any natural water resource for swimming or washing of clothes or machinery located.
- » No marking / painting on any natural features (e.g. rock formations).
- » No disturbance, defacing, destruction or removal of plants or natural features outside of the construction area, whether fenced or not, for the duration of the Contractor's presence on site.
- » The Contractor will be held liable for the replacement of any plant or feature under the protection of these specifications that is removed or damaged by the Contractor's negligence or mismanagement.

1.3. Fire risk management¹

Fires are not a regular occurrence at the site. However, fires may occasionally occur under the right circumstances. Ignition risk sources in the immediate area include:

- » Lightning strikes;
- » Activities associated with personnel within the facility; and
- » Infrastructure, such as the substation.

In accordance with EMPr, the following must be undertaken or available:

- » Basic fire-fighting equipment must be available on site at all times.
- » All necessary precautions are taken to minimise the risk of fire on the site.
- » No on-site burning of any waste materials, vegetation, litter or refuse is undertaken.
- » Any fires that occur must be immediately reported to the relevant person(s).
- » Employees are made aware of the procedure to follow in the event of a fire.
- » No open fires must be allowed on site.
- » Take immediate steps to extinguish any fire, which may break out on the construction site.
- » Include a fire resistant separation layer between storage, machinery and raw materials areas where possible.
- » Only handle flammable liquids at safe distances from sources of ignition.
- » Keep all electrical equipment used on site in working order, ensuring no fire hazard by their operation.
- » The Contractor will be held liable for any damage to property adjoining the site as a result of any fire caused by one of his employees or sub-contractors.
- » Display emergency fire incident contact numbers on site.
- » A designated fire escape route must be established and communicated to all construction site staff, as well as the neighbouring helicopter operators (if available), to ensure a safe and efficient escape route from site in the event of an emergency.
- » Smoking shall only be allowed in designated smoking areas where the relevant measures, e.g. easily accessible fire extinguisher, are in place.
- » Smoking must not be permitted in those areas where there is a fire hazard. These areas may include workshops and fuel storage areas and any areas where the vegetation or other material is such as to support the rapid spread of an initial flame.

Further mitigations are included in Appendix I of the EMPr.

1.4. Alien Plant Control

Alien invasive plants should be controlled as outlined and as per the mitigations included in the EMPr.

1.5. Erosion Management

All erosion problems should be rectified according to the Erosion Management Plan (refer to **Appendix G** of the EMPr).

¹ This needs to be undertaken through consultation with the affected landowners.

**Appendix D:
Re-vegetation and Rehabilitation Plan**

RE-VEGETATION AND REHABILITATION PLAN

1. PURPOSE

The purpose of the rehabilitation plan is to ensure that areas cleared or impacted during construction activities on Lichtenburg 2 are rehabilitated to its original state before the operation phase commences, and that the risk of erosion from these areas is reduced. The purpose of the rehabilitation plan for the site can be summarised as follows:

- » Achieve long-term stabilisation of all disturbed areas.
- » Minimise visual impact of disturbed areas.
- » Ensure that disturbed areas are rehabilitated to a condition similar to that found prior to disturbance.

This Rehabilitation Plan should be read in conjunction with other site-specific plans, including the Erosion Management Plan, Soil Management Plan, Alien Invasive Plant Management Plan, and Plant Rescue and Protection Plan. Prior to the commencement of construction, a detailed Rehabilitation Plan and Method Statement for the site should be compiled with the aid of a suitably qualified, professionally registered specialist (with a botanical or equivalent qualification).

2. RELEVANT ASPECTS OF THE SITE

The Lichtenburg 2 project site is situated in the Grassland biome and Dry Highveld Grassland Bioregion. The vegetation in and surrounding the project site is Carletonville Dolomite Grassland (Gh 15). During the Ecological survey conducted by Botha (2018), two vegetation associations (habitats) were identified within the solar and power line development footprint:

- » Association 1: *Elionurus muticus* – *Helichrysum callicamum* Savanna Grassland (both the solar footprint and the powerline corridor). This savannah type comprises a dominant open grassland with some scattered shrubs and trees (mainly *Searsia pyroides*, *S. Lancea*, *Celtis illosa* 1a and *Grewia flava*). Taller trees are relatively scarce and usually clumped together. Such clumps were, as mentioned, scarce within the project site and typically comprise of *Searsia lanceae*, *S. pyroides*, *Ziziphus ilosaa*, *Celtis ilosaa*, *Gymnosporia buxifolia* and *Asparagus laricinus*. Species of conservation importance that were observed within the unit were occasional *Boophone disticha* plants. Other conservation important plants much less frequently observed include *Ammocharis coranica* and a singular cluster of *Vachelia (Acacia) erioloba* trees was recorded just outside of the development footprint. This *V. erioloba* tree cluster is however located within the corridor area of the proposed power line Alternative 1.
- » Association 2: *Hyparrhenia hirta* – *Elionurus muticus* Palaeo-drainage Grassland. Both palaeo-valleys run in a west to east direction. One along the southern portion of the project site and the northern valley/channel infringing only very slightly into the northern most corner of the project site. The palaeo-channel is mostly flat or very gradual sloping. These palaeo-channels are relicts of historically wetter periods and merely exhibit characteristics (edaphic) of wetter periods but have lost all of their hydrological functions. Although there are still very slight incisions of the channels, it is mostly filled with a moderately to thin layer of sand and/ or silt and clay covering bedrock and stones of dolomite and chert. These palaeo-drainage lines are characterised by a plant species composition different from the surrounding drier areas and are almost entirely covered with graminoids with some forbs. Shrubs and

trees are almost absent from this channel with only occasionally the presence of *Grewia flava* and *Searsia lancea*. The grass layer is moderately tall (1m – 1.7m) and overwhelmingly dominates this plant community, typically comprising of *Themeda triandra*, *Cymbopogon caesius*, *Hyparrhenia hirta*, *Aristida congesta*, *A. junciformis*, *Eragrostis rigidior*, *E. curvula*, *E. chloromelas*, *E. plana*, *Cynodon dactylon* and *Diheteropogon amplexans*. Trampled and severely overgrazed areas are typically covered by *Aristida congesta*, *Eragrostis plana*, *Gomphrena celosioides*, *Bidens ilosa*, *Seriphium plumosum*, *Argemone ochroleuca*, *Verbena bonariensis* as well as *Schkuria pinnata*. Regarding conservation important species, only one conservation important species was observed within this palaeo-drainage grassland namely *Ammocharis coranica* and was only observed occasionally and occurring as a singular species.

The open grassland and shrublands within the project site are most likely being used for livestock farming (cattle), with a relatively low presence of game. Agricultural infrastructure and associated developments are also prominent within the project site and include large cultivated areas (mostly under irrigation and some limited dryland), cattle feedlot, buildings, artificial watering points, cement dams, cattle feeding points, the R505 Road and numerous dirt roads (twin tracks). Some mining/prospecting pits (alluvial diamonds) are also present within the project site. A little more than one third of the project site has been transformed and disturbed due to the above-mentioned agricultural activities.

3. REHABILITATION METHODS AND PRACTISES

- » Clearing of invaded areas should be conducted as per the Alien Management Plan, included in the EMPr.
- » No harvesting of vegetation may be done outside the area to be disturbed by construction activities.
- » Indigenous plant material must be kept separate from alien material.
- » Indigenous seeds may be harvested for purposes of revegetation in areas that are free of alien invasive vegetation, either at the site prior to clearance or from suitable neighbouring sites.
- » Topsoil should be reserved wherever possible on site, to be utilised during rehabilitation.
- » Sods used for revegetation should be obtained directly from the site, but not from the sensitive areas. Sods should contain at least a 50 mm topsoil layer and be minimally disturbed, in particular to existing root systems. Sods must ideally be obtained from areas as close as possible to the region that is to be rehabilitated.
- » Water used for the irrigation of re-vegetated areas should be free of chlorine and other pollutants that might have a detrimental effect on the plants.
- » All seeded, planted or sodded grass areas and all shrubs or trees planted are to be irrigated at regular intervals.
- » On steep slopes and areas where seed and organic matter retention is low, it is recommended that soil savers are used to stabilise the soil surface. Soil savers are man-made materials, usually constructed of organic material such as hemp or jute and are usually applied in areas where traditional rehabilitation techniques are not likely to succeed.
- » In areas where soil saver is used, it should be pegged down to ensure that it captures soil and organic matter flowing over the surface.
- » The final rehabilitated area should resemble the current composition and structure of the soil as far as practicably possible.
- » Progressive rehabilitation is an important element of the rehabilitation strategy and should be implemented where feasible.
- » No construction equipment, vehicles or unauthorised personnel should be allowed onto areas that have been rehabilitated.

- » Where rehabilitation sites are located within actively grazed areas, they should be fenced off; this must be undertaken in consultation with the landowner.
- » Any runnels, erosion channels or wash-aways developing after revegetation should be backfilled and consolidated and the areas restored to a proper stable condition.
- » Re-vegetated areas should be monitored frequently and prepared and revegetated from scratch should inadequate signs of surface coverage or growth be evident after two growth seasons. Adequate recovery must be assessed by a qualified botanist or rehabilitation specialist.
- » The stockpiled vegetation from the clearing operations should be reduced to mulch where possible, and retained along with topsoil to encourage seedbank regrowth and soil fertility.
- » Mulches must be collected in such a manner as to restrict the loss of seed.
- » Much must be stored for as short a period as possible.
- » Mulch is to be harvested from areas that are to be denuded of vegetation during construction activities, provided that they are free of seed-bearing alien invasive plants.
- » Where herbicides are used to clear vegetation, species-specific chemicals should be applied to individual plants only. General spraying should be strictly prohibited, and only the correct herbicide type should be applied.
- » Once rehabilitated, areas should be protected to prevent trampling and erosion.
- » Fencing should be removed once a sound vegetative cover has been achieved.

4. MONITORING AND FOLLOW-UP ACTION

Throughout the lifecycle of the development, regular monitoring and adaptive management must be in place to detect any new degradation of rehabilitated areas. During the construction phase, the Environmental Officer (EO) and EPC Contractor will be responsible for initiating and maintaining a suitable monitoring system. Once the development is operational, the Developer will need to identify a suitable entity that will be able to take over and maintain the monitoring cycle and initiate adaptive management as soon as it is required. Monitoring personnel must be adequately trained.

The following are the minimum criteria that should be monitored:

- » Associated nature and stability of surface soils.
- » Re-emergence of alien and invasive plant species. If noted, remedial action must be taken immediately, as per the alien management plan and mitigation measures contained within the EMPr.

Rehabilitation success, monitoring and follow-up actions are important to achieve the desired cover and soil protection. The following monitoring protocol is recommended:

- » Rehabilitation areas should be monitored every 4 months for the first 12 months following construction, or as per the recommendations of the relevant specialist.
- » Ensure that steep slopes are not de-vegetated unnecessarily and subsequently become hydrophobic (i.e. have increased runoff and a decreased infiltration rate) increasing the erosion potential.
- » Soil loss is related to the length of time that soils are exposed prior to rehabilitation or stabilisation. Therefore the timeframe between construction activities and rehabilitation should be minimised. Phased construction and progressive rehabilitation, where practically possible, are therefore important elements of the erosion control and rehabilitation strategy.
- » Any areas showing erosion, should be adaptively managed with particular erosion control measures, depending on the situation.

If the current state of the environment prior to construction (which will be disturbed during the construction phase) is not achieved post impact, within the specified rehabilitation period, maintenance of these areas must continue until an acceptable state is achieved (excluding alien plant species or weeds). Additional rehabilitation methods may be necessary to achieve the current state before construction commences.

Monitoring of the rehabilitation success, as well as follow-up adaptive management, combined with the clearing of emerging alien plant species should all continue for as long as is considered necessary, depending on regrowth rates.

Appendix E:
Plant Rescue and Protection Plan



Nkurenkuru

ECOLOGY & BIODIVERSITY

SACNASP REG: 400502/14

PLANT RESCUE AND **PROTECTION PLAN**

*PROPOSED LICHTENBURG 2 100MW
SOLAR PV FACILITY, LICHTENBURG,
NORTH-WEST PROVINCE*

November 2020

Prepared by:

NKURENKURU ECOLOGY & BIODIVERSITY (PTY) LTD.

Gerhard Botha (Pri Sci Nat: Ecology & Botany)

PO Box 12500, Brandhof, 9324

Cell: 084 2073454

Email: gabotha11@gmail.com

TABLE OF CONTENTS

1	PURPOSE	5
2	SCOPE.....	5
3	LEGISLATION AND STANDARDS.....	6
4	GENERAL SITE DESCRIPTION.....	6
5	EFFECT OF REMOVING INDIVIDUALS OF SPECIES OF CONSERVATION CONCERN	9
6	ANIMAL SEARCH AND RESCUE.....	10
7	PRINCIPLES OF SEARCH AND RESCUE.....	11
8	REFERENCES.....	Error! Bookmark not defined.
9	APPENDIX: PHOTOGRAPHIC GUIDE TO PROTECTED SPECIES.....	14

LIST OF ABBREVIATIONS

CARA:	Conservation of Agricultural Resources Act 43 of 1983
DEA:	Department of Environmental Affairs
EA:	Environmental Authorisation
ECO:	Environmental Control Officer
EMP:	Environmental Management Plan
NEMA:	National Environmental Management Act 107 of 1998
LFA:	Landscape Functional Analysis (Tongway and Hindley 2004)
IP:	Invasive Plant (indigenous or alien)

LIST OF DEFINITIONS:

Accelerated soil erosion: Soil erosion induced by human activities.

Acceptable cover: An acceptable cover shall mean that not less than 40% (in regions receiving less than 400 mm rain per annum), of the area rehabilitated and/or planted shall be covered with grass and other species and that there shall be no bare patches of more than 500 cm in maximum dimension.

Alien: originating from another country or continent and originally different environment, commonly used to describe plants that are not indigenous to South Africa and have become problematic (spreading rapidly, threatening existing biodiversity)

Allelopathic components: one or more biochemical compound produced by a plant and released through leaf litter or roots that suppresses the growth, survival, and reproduction of other surrounding vegetation

Bare soil: Un-vegetated soil surface, unaltered by humans

Bush encroachment: means stands of plants of the kinds specified in CARA Table 4, where individual plants are closer to each other than three times the mean crown diameter

Compacted soil surface: A soil surface that has been hardened by an outside source, causing the soil to be more compacted than the surrounding area.

Container plants: Container plants include all vegetation which are bought or supplied in acceptable containers from nurseries or vegetation lifted out of their natural position and placed in containers.

Desirable end state: the future condition or target on which the rehabilitation is designed and that will serve later as a basis for rehabilitation success evaluation. This can be based on a reference site or modelled according to available information on historic vegetation

Ecological rehabilitation: The process of assisting the recovery of a degraded or damaged ecosystem in a trajectory that renders the ecosystem fully

functional, stable, and able to develop further, but not necessarily returning to the original historic state.

Ecological restoration: The process of assisting the recovery of an ecosystem that has been degraded damaged or destroyed, in a trajectory that ultimately returns the ecosystem to its natural successional stage.

Ecosystem: The combination of biota within a given area, together with a suitable environment that sustains the biota and the interactions between biota. It can have a spatial unit of any size, but shows some degree homogeneity as far as structure, function and species composition is concerned. Small-scale ecosystems typically link up to larger scale ecosystems and all contribute to the ecosystem function and services at the landscape-scale.

Establishment of grass: All procedures necessary to produce an acceptable cover of grass on an area.

Establishment Period: The Establishment Period is defined as the period beginning from the actual planting or placing of vegetation until three months thereafter, unless otherwise specified or unless grass cover is unacceptable or unless plants have not taken.

Extinction debt: is a concept that describes the future extinction of species due to events in the past. Extinction debt occurs because of time delays between impacts on a species, such as destruction of habitat or reduction of population size, and the species' ultimate disappearance.

Geophytic: resprouting during the growing season from an underground storage organ such as bulbs, corms, tubers or rhizomes, and dying back completely during unfavourable seasons

Indigenous: refers to a plant or animal that occurs naturally in the place in which it is currently found

Invasive plant: a kind of plant which has under section 2 (3) of CARA been declared an invader plant, and includes the seed of such plant and any vegetative part of such plant which reproduces itself asexually

Landscape: Consists of a mosaic of two or more ecosystems that exchange organisms, energy, water, and nutrients.

Nursery conditions: These are the necessary conditions to maintain healthy growth of rescued and/or container plants. This includes protection of such plants against wind, frost, direct sunlight, pests, rodents, diseases, and drought. It also includes the provision of suitable water, fertilizer and any other measures required to maintain the container plants.

Period of Maintaining: The Period of Maintaining is defined as the period following directly after the Establishment Period until the end of the Period of Maintenance for the whole Contract as defined in the General Conditions of Contract, unless otherwise specified.

Revegetation: The process of establishing a vegetative cover on exposed soils, regardless of species composition or structure, as long as the species are

non-invasive and their presence will not impede the gradual process of ecological rehabilitation or –restoration.

Soil Erosion: is a natural process whereby the ground level is lowered by wind or water action and may occur as a result of inter alia chemical processes and or physical transport on the land surface.

Scarifying: To roughen the surface of soil as a preparation for seeding or topsoil addition.

Trimming: To neatly round off the levels of existing or previously shaped earthworks to blend in with the levels of other earthworks, constructed works, or natural landforms.

Transformation: The conversion of an ecosystem to a different ecosystem or land use type.

Topsoil: uppermost layer of soil, in natural vegetation maximally 30 cm, in cultivated landscapes the total depth of cultivation, containing the layer with humus, seeds and nutrients. Topsoils that are applied to landscapes to be rehabilitated must be free of refuse, large roots and branches, stones, alien weeds and/or any other agents that would adversely affect the topsoils suitability for re-vegetation.

Weed: a plant that grows where it is not wanted, and can therefore be an indigenous or alien species. An unwanted plant growing in a garden is just called a weed, but the 198 listed IPs are called “declared weeds and invaders”.

(Coetzee 2005, Clewell et al. 2005, SER 2004)

**LICHTENBURG 2 PV FACILITY, NEAR LICHTENBURG, NORTH WEST PROVINCE
PLANT RESCUE AND PROTECTION PLAN**

1 PURPOSE

The purpose of the plant rescue and protection plan is to implement avoidance and mitigation measures to reduce the impact of the development of Lichtenburg 2 on listed and protected plant species and their habitats, and to provide guidance on search and rescue of species of conservation concern.

2 SCOPE

This document is to be applied by all contractors on Lichtenburg 2.

This plan, as a requirement of the authorisation, is a legal document that must be implemented. However, the management plan is an evolving guideline that needs to be updated or adapted as progress is made with the management of species of conservation concern recorded on site.

The objective of rescuing animals and plants, rehabilitation and revegetation within the development footprint and immediate adjacent areas is:

- » Preventing the loss of species either directly or through future extinction debts and minimising impacts of development on population dynamics of species of conservation concern
- » Preserving the natural configuration of habitats as part of ecosystems, therefore ensuring a diverse but stable substrate and general environment for species to be able to become established and persist
- » Where the natural configuration of habitats has been significantly altered but will not be permanently transformed, re-create as near-natural habitats as practical to re-establish ecosystem functionality to those habitats
- » Preserving or re-creating the structural integrity of natural plant communities
- » Actively aid the improvement of indigenous biodiversity according to a desirable end state according to a previously recorded reference state
 - This reference state, if healthy, will be dynamic and able to recover after occasional disturbances without returning to a degraded state
- » Improving the ecosystem function of natural landscapes and their associated vegetation

3 LEGISLATION AND STANDARDS

Relevant legislation:

- » Conservation of Agricultural Resources Act 43 of 1983
- » Environmental Conservation Act 73 of 1989
- » National Forestry Act 84 of 1998
- » National Environmental Management Act 107 of 1998
- » National Environmental Management Act: Biodiversity Act / NEMA:BA (Act No. 10 of 2004)
- » The Transvaal Nature Conservation Ordinance (No. 12 of 1983)
- » The Bophuthatswana Nature Conservation Act (Act 3 of 1973)

4 GENERAL SITE DESCRIPTION

The development footprint is located on Portion 23 of the Farm Houthaalboomen 31, situated approximately 10 km to the north of the town of Lichtenburg. The proposed site falls under the jurisdiction of the Ditsobotla Local Municipality and within the greater Ngaka Modiri Molema District Municipality in the North West Province. The study site falls within the 2626AA quarter degree square (QDGS).

The site can be described as largely flat to slightly undulating with an average slope of 0.1% and a maximum slope of 0.6%. The typography of the project site itself can be described as follows;

- » the northern half of the project site is slightly more undulating and sloping (situated higher than the southern half of the project site). This is true for most of the northern half with the exception of the northern most tip (north-western corner) of the project site, which contains the lowest point within the project site. This low point correlates with a palaeo-drainage line (fossil river or run), which runs mostly in an east to west direction just north and mostly outside, apart from a very small section, of the project site.
- » The central portion of the project site contains a very gentle gradient (gentle southerly slope) with some micro-topographical variation.
- » The southern half of the project site, on the other hand, is located in a low lying (subsidence), mostly flat palaeo-river valley (fossil river or run), running in an east to west direction.
- » Other micro-topographical variations may be due to small "sinkhole" structures within the dolomitic areas and also likely due to the presence of termitaria. Chert outcroppings and ridges appear to be absent from the project site.

The open grassland and shrublands, within the project site, are most likely being used for livestock farming (cattle), with a relatively low presence of game. Agricultural infrastructure and associated developments are also prominent within the project site and include large cultivated areas (mostly under irrigation and some limited dryland), cattle feedlot, buildings, artificial watering points, cement dams, cattle feeding points, the R505 Road and numerous dirt roads (twin tracks). Some mining/prospecting pits (alluvial diamonds) are also present within the project site. A little more than one third of the project site has been transformed and disturbed due to the above-mentioned agricultural activities.

The project site is situated in the Grassland biome and Dry Highveld Grassland Bioregion. The vegetation in and surrounding the project site is Carletonville Dolomite Grassland (Gh 15). During the Ecological survey conducted by Botha (2018), two vegetation associations (habitats) were identified within the solar and power line development footprint:

- » Association 1: *Elionurus muticus* – *Helichrysum callicamum* Savanna Grassland (both the solar footprint and the powerline corridor). This savannah type comprises a dominant open grassland with some scattered shrubs and trees (mainly *Searsia pyroides*, *S. Lancea*, *Celtis 7ilosa7a* and *Grewia flava*). Taller trees are relatively scarce and usually clumped together. Such clumps were, as mentioned, scarce within the project site and typically comprise of *Searsia lanceae*, *S. pyroides*, *Ziziphus ilosaa*, *Celtis ilosaa*, *Gymnosporia buxifolia* and *Asparagus laricinus*. Species of conservation importance that were observed within the unit were occasional *Boophone disticha* plants. Other conservation important plants much less frequently observed include *Ammocharis coranica* and a singular cluster of *Vachelia (Acacia) erioloba* trees was recorded just outside of the development footprint. This *V. erioloba* tree cluster is however located within the corridor area of the proposed power line Alternative 1.
- » Association 2: *Hyparrhenia hirta* – *Elionurus muticus* Palaeo-drainage Grassland. Both palaeo-valleys run in a west to east direction. One along the southern portion of the project site and the northern valley/channel infringing only very slightly into the northern most corner of the project site. The palaeo-channel is mostly flat or very gradual sloping. These palaeo-channels are relicts of historically wetter periods and merely exhibit characteristics (edaphic) of wetter periods but have lost all of its hydrological functions. Although there are still very slight incisions of the channels, it is mostly filled with a moderately to thin layer of sand and/ or silt and clay covering bedrock and stones of dolomite and chert. These palaeo-drainage lines are characterised by a plant species composition different from the surrounding dryer areas and is almost entirely covered with graminoids with some forbs. Shrubs and trees are almost absent from this channel with only occasionally the presence of *Grewia flava* and *Searsia lancea*. The grass layer is moderately tall (1m – 1.7m) and overwhelmingly dominates this plant community, typically comprising of *Themeda triandra*, *Cymbopogon caesius*, *Hyparrhenia hirta*,

Aristida congesta, *A. junciformis*, *Eragrostis rigidior*, *E. curvula*, *E. chloromelas*, *E. plana*, *Cynodon dactylon* and *Diheteropogon amplexans*. Trampled and severely overgrazed areas are typically covered by *Aristida congesta*, *Eragrostis plana*, *Gomphrena celosioides*, *Bidens ilosa*, *Seriphium plumosum*, *Argemone ochroleuca*, *Verbena bonariensis* as well as *Schkuria pinnata*. Regarding conservation important species, only one conservation important species was observed within this palaeo-drainage grassland namely *Ammocharis coranica* and was only observed occasionally and occurring as a singular species.

Conservation important species found during the ecological survey (accompanied with general information regarding search and rescue targets and methods) include:

» *Vachelia (Acacia) erioloba*:

- Protected within the relevant Provincial Conservation Acts and National Forest Act
- Red Data: Declining
- A single isolated population of three species (cluster) was observed within the power line corridor (just outside of the PV facility's development footprint)
- These tree species are medium sized (average height of 3.5m and stem diameter of 0.9m)
- No relocation possible
- Disturbance and destruction can be avoided through a slight amendment of the proposed power line route around this cluster and is the recommended mitigation measure (as recommended within the Ecological Impact Assessment Report)

» *Boophone disticha*:

- Red Data: Declining
- Deciduous bulbous plant with thick covering of dry scale above the ground
- Dry grassland and on rocky slopes
- Can be relocated – may be difficult to locate once the species are in their dormant phase – look out for protruding bulb scales
- Protect from poaching (harvested and sold for medicinal purposes)
- Sap of leaves and especially sap of inside bulb extremely toxic
- Aim to rescue at least 80%, preferably 100%

» *Ammocharis coranica*

- Protected within the relevant Provincial Conservation Acts
- Deciduous bulb covered in thinly layered tunics
- Easy to relocate and replant, aim to rescue at least 80%, preferably 100%.

Species that were not found during the ecological survey but may likely occur (according to BODATSA) within the project site (species that might have been dormant during the time of the ecological survey) include the following:

Table 1: Species listed as conservation worthy within the South African Red List, National Forest Act (NFA), Transvaal Nature conservation Ordination (TNCO) and Bophuthatswana Nature Conservation Act (BNCA).

Species	Status
<i>Gladiolus elliotii</i>	TNCO & BNCA
<i>Gladiolus permeabilis</i>	TNCO & BNCA
<i>Crinum graminicola</i>	TNCO & BNCA
<i>Crinum macowanii</i>	TNCO, BNCA & Declining
<i>Brachystelma foetidum</i>	TNCO & BNCA
<i>Brachystelma incanum</i>	TNCO, BNCA & Vulnerable
<i>Pelargonium dolomiticum</i>	TNCO, BNCA
<i>Pelargonium sidoides</i>	TNCO & BNCA & Declining
<i>Habenaria epipactidea</i>	TNCO & BNCA
<i>Cleome conrathii</i>	Near Threatened
<i>Hypoxis hemerocallidea</i>	TNCO, BNCA & Declining

A pre-construction walk-through of the final development footprint for species of conservation concern prior to the commencement of the construction phase was recommended within the Ecological Assessment Report and following such a survey this Plant Rescue and Protection Plan should be updated accordingly.

5 EFFECT OF REMOVING INDIVIDUALS OF SPECIES OF CONSERVATION CONCERN

Species of conservation concern are declining either due to overexploitation, their natural re-establishment rates after destruction are extremely low, or because their range of occupancy is limited and further infringed on by development. Most plant populations require a certain minimum number of individuals within a population or metapopulation to allow for sufficient genetic transfer between individuals. This prevents genetic erosion and hence weakening of the ability of individuals to persist in their environments. Similarly, where the distance between metapopulations is significantly increased due to fragmentation and the resultant loss of some populations, populations may suffer genetic decline due to restricted movement of pollen. Pollinators or other species that depend on a particular plant species for a specific microhabitat or food source may be equally affected because of the reduction of available resources. Therefore, the aim of plant rescue actions is always to maintain as many individuals of a plant population in as close proximity to the original habitat as possible to minimise loss of individuals and fragmentation of populations to prevent the creation of future extinction debts of the development.

6 ANIMAL SEARCH AND RESCUE

Several active animal burrows, as well as sightings of animals were made during the fieldwork undertaken for the Ecological Impact Assessment. Hares, most rodents and larger mammals will be able to move away rapidly from construction activities if vehicles adhere to speed limits set on access roads (60 km/h) and within the construction site (30 km/h). However, smaller burrowing animals and slower-moving reptiles such as tortoises will have to be moved outside of the construction area if and where necessary.

During induction, staff must be made aware of and requested to always be on the lookout for animals, active burrows, tortoises or nests, and report such sightings on the construction site immediately to the EO and ECO for action. The EO will also be responsible to inspect all surfaces just ahead of construction to detect active burrows and nests, for which professional contractors will have to be brought in to extract the animals and release them outside of the footprint area.

Trenches, while open, must also be inspected on a daily basis, especially before being closed, for the presence of fauna that may have become trapped. Deep trenches (deeper than 1.5 meters) left open overnight should be visibly barricaded as an effort to prevent larger animals from falling into the trenches. Any animals found must be removed in a safe manner, unharmed, and placed in an area where the animal will be safe. If the ECO or contractor is unable to assist in the movement of a fauna species, ensure a member of the conservation authorities assists with the translocation.

No snake species found within trenches or the rest of the development footprint may be handled by the ECO, contractor or any other staff member. If noted, the conservation authorities should be contacted for assistance or must recommend a qualified snake handler. These drier habitats provide preferable habitat for poisonous species such as puff adder (*Bitis arietans*) and cape cobra (*Naja nivea*). Some non-poisonous species such as for example, mole snakes (*Pseudaspis cana*) tend to have colour variations similar to that of poisonous snakes such as cape cobra and rinkhals (*Hemachatus haemachatus*), whilst the Rhombic Egg Eater (*Dasypeltis scabra*) can sometimes easily be mistaken for a Common Night Adder (*Causus rhombeatus*) or a juvenile puff adder. Therefore, accurate identification might be difficult and therefore the reason for recommending that only a qualified snake handler removes these species.

All mammal, large reptiles and avifauna species found injured during construction will be taken to a suitably qualified veterinarian or rehabilitation centre to either be put down in a humane manner or cared for until it can be released again.

7 PRINCIPLES OF SEARCH AND RESCUE

Successful plant rescue can only be achieved if:

- » Species can be removed from their original habitat with minimal damage to the plant, especially the roots.
- » All plants removed are safely stored and treated according to their specific requirements prior to being transplanted again.
- » They are relocated into a suitable habitat and protected from further damage and all disturbances to aid their re-establishment.
- » Timing of planting activities is planned with the onset of the growing season.
- » Steps are taken where necessary to aid the initial establishment of vegetation, including occasional watering.

The following principles apply in terms of plant rescue and protection:

- » Prior to construction, a walk-through of the final development footprint should be undertaken by a suitably qualified botanist/ecologist to locate and identify all listed and protected species which fall within the development footprint, as well as to identify species suitable for search and rescue.
- » A permit (obtained from North West Department of Rural, Environment and Agricultural Development (READ)) is required to translocate or destroy any listed and protected species even if the plants are not moved outside of the property boundaries. This permit should be obtained prior to any search and rescue operations being undertaken.
- » Where suitable species are identified, a search and rescue operation of these species should be undertaken within the development footprint prior to the commencement of construction.
- » The identified *V. erioloba* patch should be demarcated during the construction phase and any disturbance of this area (during construction as well as operation phase) must be avoided.
- » As far as possible, timing of search and rescue activities should be planned with the onset of the growing season.
- » Affected individuals should be translocated to a similar habitat outside of the development footprint and marked for monitoring purposes. For each individual plant that is rescued, the plant must be photographed before removal, tagged with a unique number or code and a latitude longitude position recorded using a hand-held GPS device.
- » The EO must be informed and present where ground works are initiated on virgin soils and where large bulbs or plants with large tubers become exposed and uprooted during initial ground works, these species should be extracted from the topsoil and be stored as recommended on-site until they can be replanted.

- » The rescued plants must be planted into a container to be housed within a temporary nursery on site or immediately planted into the target habitat.
- » Rescued plants, if re-planted, should be placed as close as possible to where they were originally removed. Re-planting must cause as little disturbance as possible to existing natural ecosystems. The position of the rescued individual/s must be recorded to aid in future monitoring of that plant.
- » During construction, the ECO must monitor vegetation clearing at the site. Any deviations from the plans that may be required should first be checked for listed species by the ECO or EO and any listed species present which are able to survive translocation should be translocated to a safe site.
- » Any listed species suitable for translocation observed within the development footprint that were not previously observed must be translocated to a safe site.
- » The collecting of plants or their parts should be strictly forbidden. Appropriate signage in this regard should be placed at the entrance gates to the site. Staff should be informed of the legal and conservation aspects of harvesting plants from the wild as part of the environmental induction training.
- » Sensitive habitats and areas outside project development should be clearly demarcated as no go areas during the construction and operation phases to avoid accidental impacts.



8 REFERENCES

- Clewell, A., Rieger, J. and Munro, J. (2005). *Guidelines for Developing and Managing Ecological Restoration Projects, 2 Edition*. www.ser.org and Tucson: Society for Ecological Restoration International.
- Coetsee, K. (2005). *Caring for Natural Rangelands*. Scottsville: University of KwaZulu-Natal Press.
- Dekker, S. C., M. Rietkerk, et al. 2007. Coupling microscale vegetation-soil water and macroscale vegetation-precipitation feedbacks in semiarid ecosystems. *Global Change Biology* 13: 671-678.
- Department of Environmental Affairs,(1983). *Conservation of Agricultural Resources Act 43 of 1983*. Pretoria: Department of Environmental Affairs.
- Esler, K.J., Milton, S.J., Dean, W.R.J. (eds). 2006. *Karoo Veld Ecology and Management*. Briza
- Holmes, P.M. and Richardson, D.M. (1999). *Protocols for restoration based on recruitment dynamics, community structure, and ecosystem function: Perspectives from South African Fynbos*. *Restoration Ecology* 7(3): 215-230
- Paton, I. (2011). *Geological Impact Assessment Report*. George: Outenique Geotechnical services Civil Laboratories.

- Society for Ecological Restoration International Science & Policy Working Group. 2004. *The SER International Primer on Ecological Restoration*. www.ser.org & Tucson: Society for Ecological Restoration International.
- Tongway, D.J. and Hindley, N.L. (2004) *Landscape Function Analysis: Procedures for Monitoring and Assessing Landscapes*, CSIRO Sustainable Ecosystems, CANBERRA, AUSTRALIA
- Tongway, D.J., Freudenberger, D.O., Noble, J.C., and Hodgkinson, K.C. (Eds). (2003). *Landscape Ecology, Function and Management*. CSIRO Sustainable Ecosystems, CANBERRA, AUSTRALIA

9 APPENDIX: PHOTOGRAPHIC GUIDE TO PROTECTED SPECIES

PLANT SPECIES FOUND DURING WALK-THROUGH SURVEY

	<p><i>Boophone disticha</i></p> <p>Protected: Red Data List (Declining)</p> <ul style="list-style-type: none">○ Deciduous bulbous plant with thick covering of dry scale above the ground○ Dry grassland and on rocky slopes○ Can be relocated – may be difficult to locate once died back (dormant phase) – look out for protruding bulb scales○ Protect from poaching (harvested and sold for medicinal purposes)○ Sap of leaves and especially sap of inside bulb extremely toxic○ Aim to rescue at least 80%, preferably 100%
	<p><i>Vachelia (Acacia) erioloba</i></p> <p>Protected: Relevant Provincial Conservation Act, National Forest Act and Red Data List (Declining)</p> <ul style="list-style-type: none">○ A single isolated population of three species (cluster) was observed within the power line corridor (just outside of the PV facility's development footprint)○ These tree species are medium sized (average height of 3.5m and stem diameter of 0.9m)○ No relocation possible○ Disturbance and destruction can be avoided through a slight amendment of the proposed power line route around this cluster and is the recommended mitigation measure (as recommended within the Ecological Impact Assessment Report)
	<p><i>Ammocharis coranica</i></p> <p>Protected: Relevant Provincial Conservation Act</p> <ul style="list-style-type: none">○ Deciduous bulb covered in thinly layered tunics○ Dry grassland and on rocky slopes○ Can be relocated – may be difficult to locate once died back (dormant phase) – look out for protruding bulb scales○ Sap of leaves and especially sap of inside bulb extremely toxic○ Aim to rescue at least 80%, preferably 100%

**Appendix F:
Traffic Management Plan**

PRINCIPLES FOR TRAFFIC MANAGEMENT

1. PURPOSE

The purpose of this Traffic Management Plan (TMP) is to address regulatory compliance, traffic management practices, and protection measures to help reduce impacts related to transportation and the construction of temporary and long-term access within the vicinity of the Lichtenburg 2 project site. The objectives of this plan include the following:

- » To ensure compliance with all legislation regulating traffic and transportation within South Africa (National, Provincial, Local & associated guidelines).
- » To avoid incidents and accidents while vehicles are being driven and while transporting personnel, materials, and equipment to and from the project site.
- » To raise greater safety awareness in each driver and to ensure the compliance of all safe driving provisions for all the vehicles.
- » To raise awareness to ensure drivers respect and follow traffic regulations.
- » To avoid the deterioration of access roads and the pollution that can be created due to noise and emissions produced by equipment, machinery, and vehicles.

2. RELEVANT ASPECTS OF THE PROJECT

The road network within the area is operating at an acceptable level of service. There are no congestion problems, queue delays and delays in the surrounding road network. The routes leading to the site are Provincial and National Roads.

A formal gravel access road currently provides access from the Regional Road (R505), to the project site. The gravel road then becomes a gravel track, leading up to a gate used to access the Lichtenburg 2 project site. This is a SANRAL approved access.

During the construction phase imported elements associated with the development of Lichtenburg 2 will be shipped to and transported from the nearest and most practical port. It is estimated that the total number of heavy vehicle trips would vary between 4500 and 6000 during the construction phase. The calculated number of daily trips would be between 15 and 25. The impact of this on the road network would be negligible, as the additional peak hourly traffic would at most be 2 trips. The low construction and post construction traffic would have no significant impact on the existing traffic levels.

During the operation phase the total number of trips to be generated by the permanent workforce during the AM and PM peak period is 18 vehicles per hour. No other trips are expected to be generated during the operation phase and therefore the additional traffic is not considered to have a significant effect on the internal roads or the access roads and surrounding areas. The significance of the traffic impacts during the operation phase will be low with the implementation of the recommended mitigation measures.

3. TRAFFIC AND TRANSPORTATION MANAGEMENT PRINCIPLES

- » Prior to the commencement of construction the contractor must develop their own detailed Transport Management Plan (TMP) based on traffic volumes and road carry capacity outlines.

- » The transport contractor must ensure that all required permits for the transportation of abnormal loads are in place prior to the transportation of equipment and project components to the project site. Specific abnormal load routes must be developed with environmental factors taken into consideration.
- » Before construction commences, authorised access routes must be clearly marked in the field with signs or flagging.
 - * Traffic signs used must conform to the National Road Traffic Act and South African National Standards.
 - * Appropriate signs must be installed at locations as deemed necessary.
 - * Signage must be placed at intersections, speed limit alterations, severe changes in road grading, where road hazards are located and where usual traffic flow changes abruptly.
 - * All traffic signs must be obeyed by all staff and visitors on site, without exception.
- » The EPC Contractor must review the location of the designated access and will be responsible for ensuring construction travel is limited to designated routes.
- » All employees must attend an environmental training program (e.g. toolbox talks) by the Environmental Officer (EO). Through this program, employees will be instructed to use only approved access roads, drive within the delineated road limits, and obey jurisdictional and posted speed limits to minimise potential impacts to the environment and other road users.
- » The contractor will be responsible for making sure that their suppliers, vendors, and subcontractors strictly comply with the principles of this TMP and the contractor's TMP.
- » Adjacent landowners must be notified of the construction schedule.
- » Access roads and entrances to the site should be carefully planned to limit any intrusion on the neighbouring property owners and road users.
- » Signs must be posted in the surrounding area to notify landowners and others of the construction activity.
- » Flagging must be provided at access points to the project site and must be maintained until construction is completed on the site.
- » Speed limits must be established prior to commencement of construction and enforced for all construction traffic. The following limits are suggested for internal roads:
 - * 60 km/hour where sign posted.
 - * 40 km/hour where sign posted.
 - * 20km/hour around workshop areas, in all car parks and yards.
 - * A warning system, penalties or fines must be put in place where speed limits are not adhered to.
- » Speed controls and the implementation of appropriate dust suppression measures must be enforced to minimise dust pollution.
- » Throughout construction the contractor will be responsible for monitoring the condition of roads used by project traffic and for ensuring that roads are maintained in a condition that is comparable to the condition they were in before the construction began.
- » Inspect traffic/road signs regularly for cleanliness, condition and appropriateness. Take immediate action to rectify any problems with signage.
- » Drivers must have an appropriate valid driver's license and other operation licences required by applicable legislation.
- » All vehicles must be maintained in good mechanical, electrical, and electronic condition, including but not limited to the brake systems, steering, tires, windshield wipers, side mirrors and rear view mirror, safety belts, signal indicators, and lenses.
- » Any traffic delays attributable to construction traffic must be co-ordinated with the appropriate authorities.
- » No deviation from approved transportation routes must be allowed, unless roads are closed for reasons outside the control of the contractor.

- » Impacts on local communities must be minimised. Consideration should be given to limiting construction vehicles travelling on public roadways during the morning and late afternoon peak commute time.
- » A driver must not use the vehicle's horn except on the grounds of safety.
- » Drivers of vehicles must always keep to the left and must be observant of other road users.
- » Drivers must follow communication procedures and shall where applicable be trained in the correct use of two-way radios.
- » Ensure all staff are trained upon entering the site regarding the meaning and correct response to each traffic sign utilised on site.
- » All light vehicles must be fitted with a flashing amber strobe or revolving light.
- » Persons authorised to operate on site must have a legal valid appropriate code provincial driver's license and competency certificate where applicable.
- » No passengers are allowed in any construction vehicles. If an assistant is required, they must obtain permission.
- » Vehicles must be maintained at approved intervals and must be inspected daily before use to ensure safe operation.
- » All vehicles must only be used within the design specifications and limits set by the manufacturer.
- » All construction vehicles will be used according to the Health and Safety Plan and related Method Statements and/or Risk Assessments.
- » Weather and road conditions must be sufficient to allow safe vehicle operation to proceed. Head lights must be turned on at all times.
- » No vehicle will be driven with any defect that may impact on the safe operation of that vehicle.
- » Two-way radios shall only be used for official/work related matters.
- » The use of mobile phones while driving a vehicle is prohibited.
- » All vehicles shall carry a fire extinguisher (Dry Powder); 2.5kg for light vehicles, 4.5kg for haul trucks and 9kg for machinery.

4. MONITORING

- » The principal contractor must ensure that all vehicles adhere to the speed limits.
- » A speeding register must be kept with details of the offending driver.
- » Repeat offenders must be penalised.

Appendix G:
Stormwater and Erosion Management Plan

LICHTENBURG 2 PHOTOVOLTAIC FACILITY AND ASSOCIATED INFRASTRUCTURE



CONCEPTUAL STORMWATER MANAGEMENT PLAN

NOVEMBER 2018



P O Box 381
Century City
7441
Tel. +27 21 555 0400

Rev	Description	Date
0	Issued in Draft	October 2018
1	For Submission	November 2018

This report was prepared and reviewed by the undersigned.

Prepared:

Sonet Gerber,
Civil Technologist

Reviewed:

Waseemah Isaacs
Principal Civil Technologist

This report was prepared by Knight Piésold Ltd. for the account of ABO Wind Lichtenburg 2 PV (Pty). Report content reflects Knight Piésold's best judgement based on the information available at the time of preparation. Any use a third party makes of this report, or any reliance on or decisions made based on it is the responsibility of such third parties. Knight Piésold Ltd. accepts no responsibility for damages, if any, suffered by any third party as a result of decisions made or actions based on this report. Any reproductions of this report are uncontrolled and might not be the most recent revision.

Table of Contents

1. INTRODUCTION	1
2. DEFINITIONS AND ASSUMPTIONS	1
3. EXISTING SITE CONDITIONS	2
3.1. Location	2
3.2. Topography, Geomorphology and Vegetation (Drainage Characteristics).....	2
3.3. Geology and Soils.....	4
3.4. Climate and Hydrology.....	5
4. STORMWATER CALCULATIONS.....	6
4.1. Runoff Coefficient	6
4.2. Time of Concentration.....	8
4.3. Point Intensity	8
4.4. Runoff	8
5. PROPOSALS FOR STORMWATER MANAGEMENT.....	11
5.1. Side Drains	12
5.2. Berms.....	12
5.3. Outlets.....	12
6. EROSION PROTECTION MEASURES	13
7. WASTE WATER MANAGEMENT	15
8. CONCLUSIONS AND RECOMMENDATIONS.....	16
9. REFERENCES	16
10. ANNEXURES	17

List of Figures

Figure 3.1: Locality Plan.....	2
Figure 3.2: Drainage Pattern of Existing Site.....	3
Figure 3.3: Catchment Areas	4
Figure 3.4: Monthly Rainfall for Lichtenburg	5
Figure 3.5: Average Monthly Temperatures for Lichtenburg	6
Figure 4.1: Conceptual Layout of PV Panels	9
Figure 4.2: Drainage pattern for conceptual layout of PV panels	9
Figure 4.3: Access Roads	11
Figure 5.1: Typical Berm Detail.....	12
Figure 6.1: Typical Stone Pitched Side Drain	13
Figure 6.2: Typical Concrete Lined Side Drain	13
Figure 6.3: Typical inlet erosion protection measures	14
Figure 6.4: Typical outlet erosion protection measures	14

List of Tables

Table 4.1: Pre-development Runoff Coefficient Percentages.....	7
Table 4.2: Post-development Runoff Coefficient Percentages	7

1. INTRODUCTION

Knight Piésold Consulting was appointed by Atlantic Energy on behalf of ABO Wind Lichtenburg 2 PV (Pty) Ltd to investigate and compile a conceptual Stormwater Management Plan for the proposal of a photovoltaic (PV) energy facility and associated infrastructure. Portion 23 of the Farm Houthaalbomen No.31 has been identified as the preferred site suitable for the development of a commercial PV facility, which is capable of generating 100MW. The total area of the project site is approximately 496ha.

This report should be viewed as a localised high-level study and not as a detailed design report. The objective is purely to demonstrate that stormwater from the new development could be managed and controlled in an optimised and non-destructive manner. The purpose of this study is to prepare a conceptual Stormwater Management Plan (SMP) to support the Environmental Impact Assessment Process of the proposed Lichtenburg 2 PV facility.

The SMP includes the following:

- Determining the catchment area of the project site;
- Defining the topography, slope gradients and rainfall intensities;
- Estimating expected floods for the catchment;
- Confirming of existing drainage patterns and streams;
- Proposing drainage elements such as side drains, outlets and other mitigation measures to accommodate the resultant stormwater flows.

2. DEFINITIONS AND ASSUMPTIONS

The following assumptions are made on stormwater calculations and are deemed to be adequate for a conceptual investigative report:

- The Rational Method is used for flood calculations, which is widely accepted to be very accurate for areas of this size and
- The recurrence period applied is a 1:50 year design flood.
- There are no watercourses that will affect planning and the design of the solar facility.

3. EXISTING SITE CONDITIONS

3.1. Location

The site is situated approximately 10km to the north of the town of Lichtenburg, and 7km south-east of Bakerville, situated in the North West Province of South Africa, see *Figure 3.1*. The site falls within ward 16 of the Ditsobotla Local Municipality. A formal gravel access road currently provides access from the regional road (R505) to the property. This gravel road then becomes a formal 2-wheel track, leading up to a gate used to access the project site.

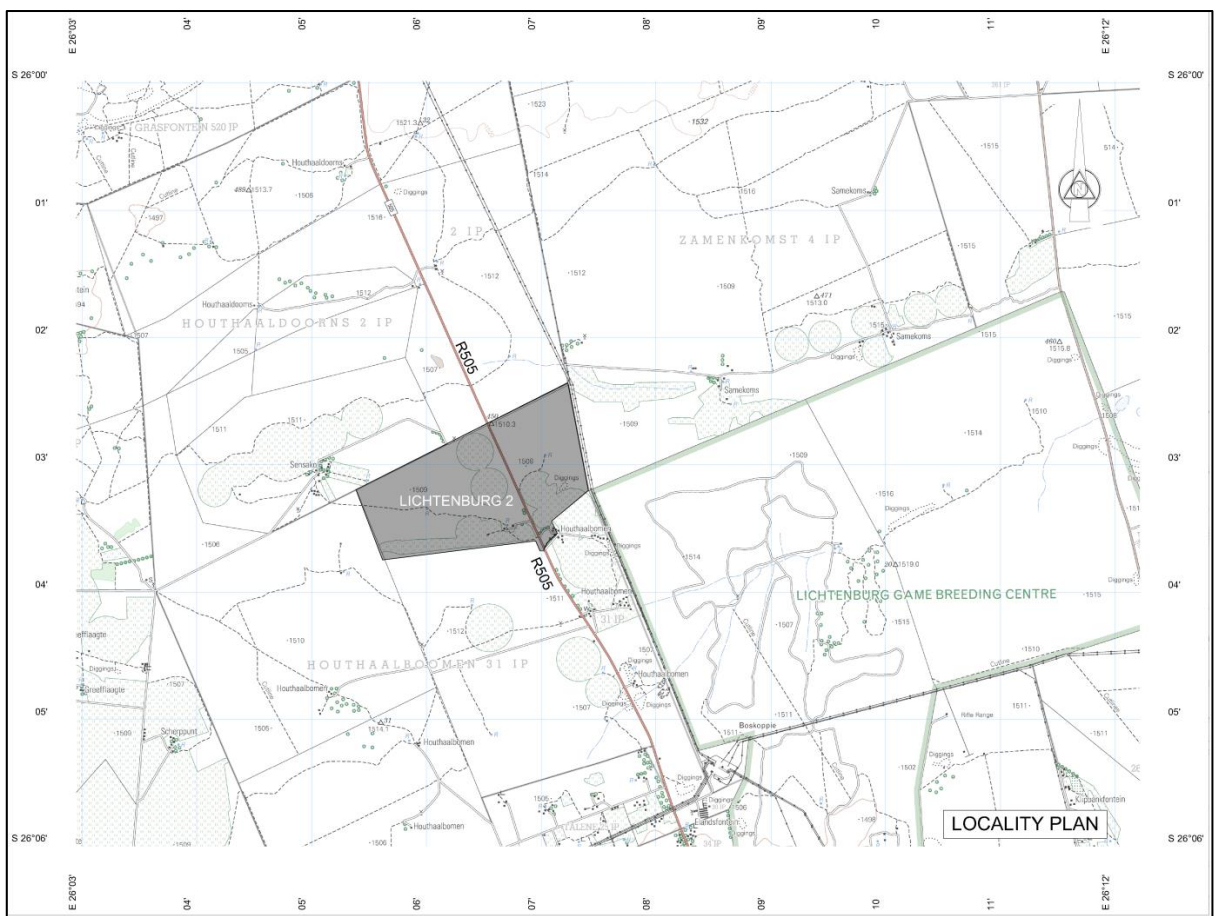

Figure 3.1: Locality Plan

3.2. Topography, Geomorphology and Vegetation (Drainage Characteristics)

The North West Province is situated in the central-northern extent of South Africa and is characterised by altitudes ranging between 900 and 1 800m above mean sea level (AMSL). This makes it one of the provinces with the most gradual slopes within the country. Lichtenburg 2 is situated at elevations of between 1 507m AMSL and 1 517m AMSL, the elevation gain/loss being

a mere 10m. The project site can therefore be described as being flat with an average slope of 0.3% and a maximum slope of 1.4%. The project site itself can be described as a plain with a slight southern inclination. The property is characterised by open grassland and shrub lands and is being used for crop farming.

3.2.1. Drainage Patterns and Runoff Characteristics

The approximate total drainage area of the site is around 496 hectares. The northern half of the project site is slightly more undulating and sloping, and mostly situated at a higher elevation than the southern half. The northern portion of the site (north-west corner) correlates with a geological structure, fault line or dyke. The central portion of the project site contains a very gentle gradient, in a southerly direction, with some micro-topographical variations. The southern part of the project site is located in a low lying, mostly flat palaeo-river valley (fossil river or ancient river), which runs in an east-to-west direction. Other micro-topographical variations may possibly be due to small sinkhole structures within the dolomitic areas. The slope gradient for the longest drainage path length within the catchment area is 0.15%. The existing drainage patterns are depicted in *Figure 3.2* below.

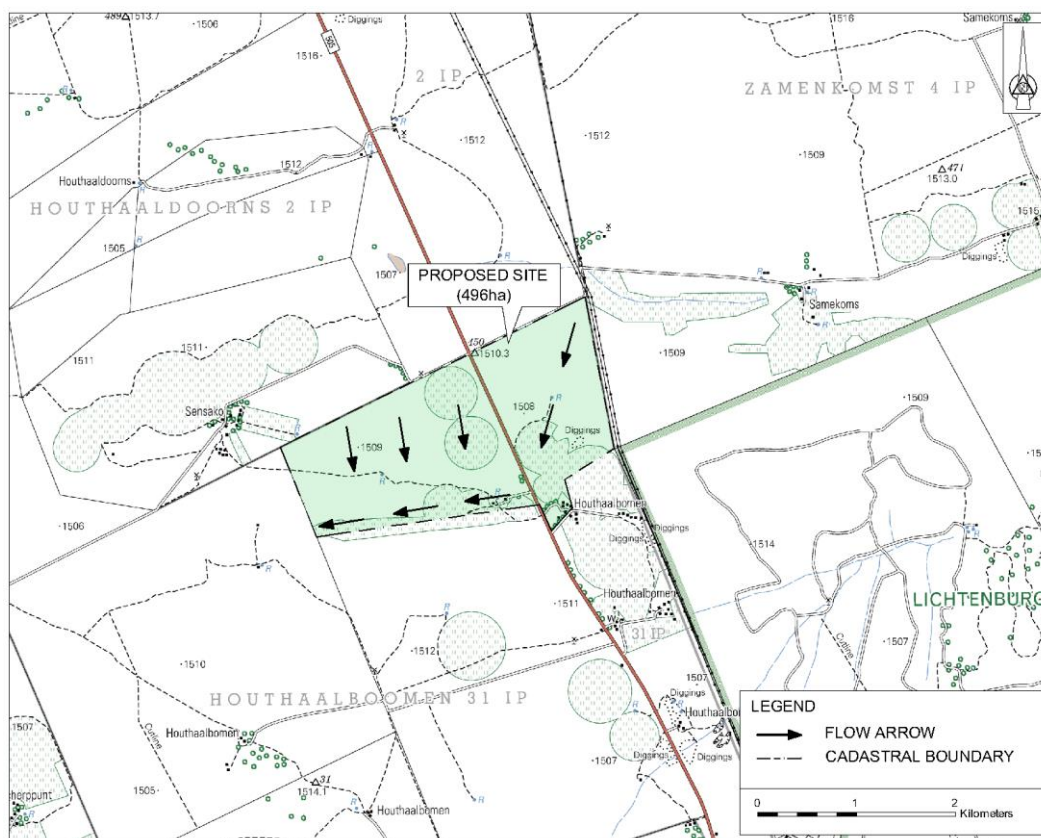

Figure 3.2: Drainage Pattern of Existing Site

It should be noted that, in the absence of detailed topographical survey information, 1:10 000 orthographical maps together with spot height data taken on site were used to establish the drainage patterns. The greater catchment area is 1 005ha, see *Figure 3.3* below. The sparse vegetation, together with the flat gradient and semi-permeable soils yield low runoff coefficients.



Figure 3.3: Catchment Areas

3.3. Geology and Soils

The site overlies dolomites and associated marine sedimentary rocks and comprises mainly dolomite and chert. The dominant soil forming processes have been rock weathering and the formation of orthic topsoil horizons, as well as common clay illuviation, all giving rise to lithocutanic horizons. The soil forms that represent these processes are Glenrosa and Mispah, which tend to be reddish-brown in colour, and are weakly structured soils. Surface rock may be present, and hillcrest areas within this land type are characterised by rock, Mispah soils and occasionally shallow Hutton form soils. The site is generally viewed as permeable and the ingress of rainwater into the soils happens relatively quickly.

3.4. Climate and Hydrology

Lichtenburg 2 is located within the Lower Vaal Water Management Area (WMA). Minimal usable surface runoff is generated within the WMA as a result of the low rainfall, flat topography, and sandy soil conditions.

Lichtenburg is typically hot in summer and mild-to-cold in winter. It experiences summer rainfall in the form of thunderstorms with a mean annual average precipitation of 601 mm; see *Figure 3.4* for a graph indicating the average monthly rainfall figures. At an average temperature of 21.7°C, January is the hottest month of the year, and June the coldest at 9.9°C; see *Figure 3.5* for average monthly temperatures. The information was gathered from the weather station at the Lichtenburg Municipality.

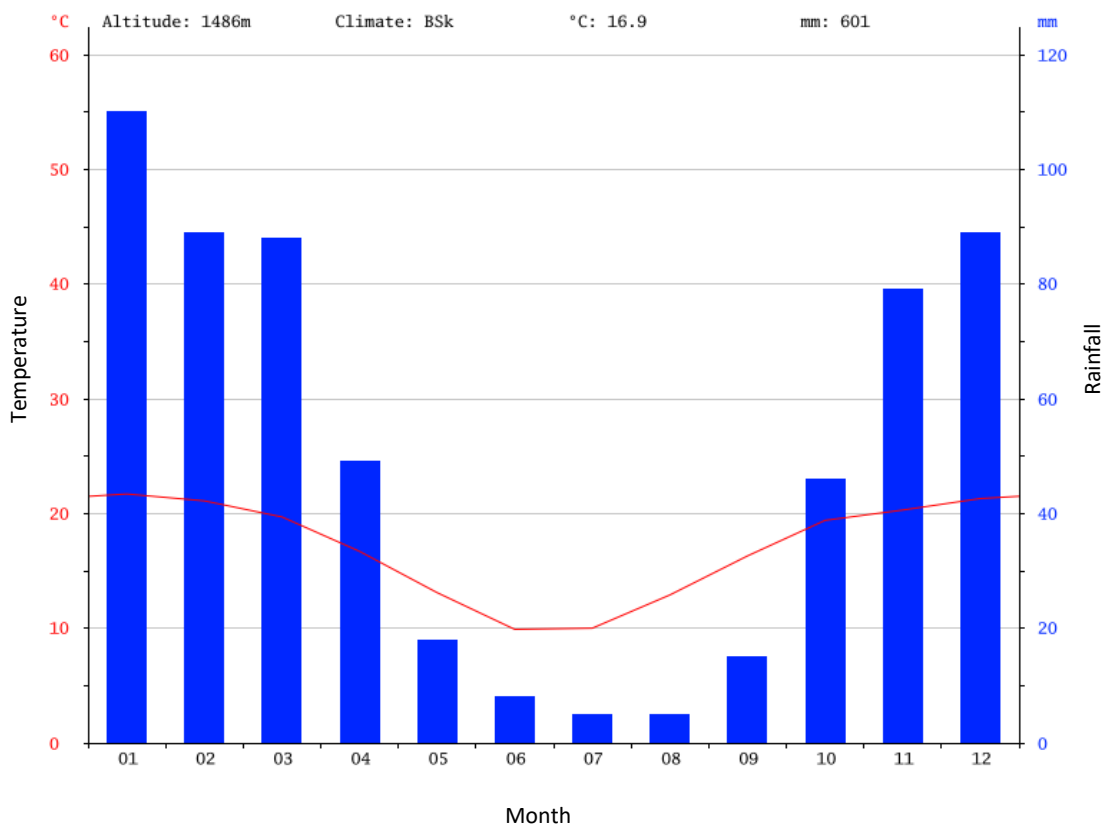

Figure 3.4: Monthly Rainfall for Lichtenburg

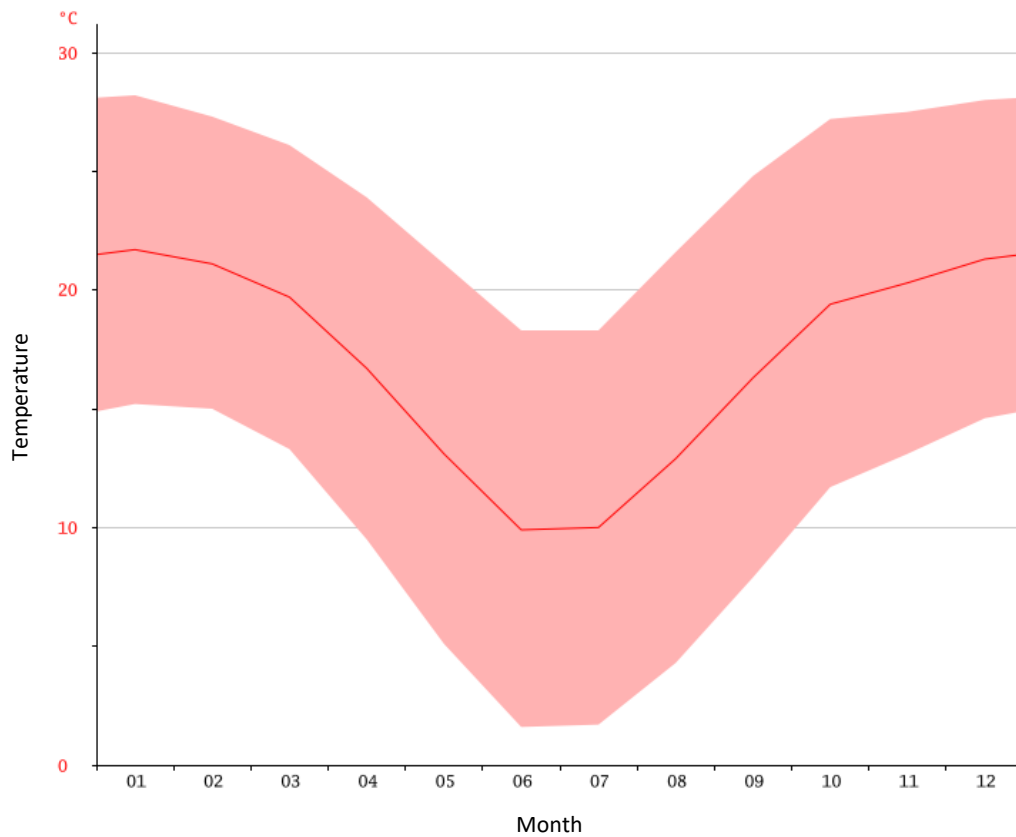

Figure 3.5: Average Monthly Temperatures for Lichtenburg

4. STORMWATER CALCULATIONS

As mentioned before, the calculations to determine the run off volumes and intensities of the site are based on the Rational Method with a return period of 1:50 years.

4.1. Runoff Coefficient

4.1.1. Pre-development

The pre-development runoff coefficient was calculated by making allowance for the rock outcrop observed on site during the visual inspection, and hence 5% was therefore allowed for impermeable soil. The site also mainly consists of grasslands with a portion of the site consisting of light bush and cultivated land, see run-off coefficient percentages listed in *Table 4.1* below.

Table 4.1: Pre-development Runoff Coefficient Percentages

Permeability	% Applied	Vegetation	% Applied
Very	0	Thick bush & Forest	0
Permeable	50	Light Bush & Cultivated Land	30
Semi-Permeable	45	Grasslands	70
Impermeable	5	Bare	0
<i>TOTAL</i>	<i>100</i>	<i>TOTAL</i>	<i>100</i>

The calculated runoff coefficient based on the above for the pre-development phase is 0.307; refer *Annexure A* for further detailed calculations in this regard.

4.1.2. Post-development

The post-development runoff coefficient took the installation of the panels into account as well as the vegetation alterations that may occur post construction. An area of 280ha (approximately 56% of the total project site) is required for the development of Lichtenburg 2 PV. Even though the PV panels are impermeable, they will be mounted on bases that only cover a small surface area. A small percentage of the run-off coefficient was thus allowed for hardened surface.

During the construction phase, vegetation will be lost, and this may not fully recover due to the shade that will be created by the panels post construction. A further allowance was made by amending the vegetation area when calculating the post-development peak runoff flows by allowing for 20% bare areas or no vegetation. These percentage figures are reflected in *Table 4.2* below.

Table 4.2: Post-development Runoff Coefficient Percentages

Permeability	% Applied	Vegetation	% Applied
Very	0	Thick bush & Forest	0
Permeable	45	Light Bush & Cultivated Land	30
Semi-Permeable	45	Grasslands	50
Impermeable	10	Bare	20
<i>TOTAL</i>	<i>100</i>	<i>TOTAL</i>	<i>100</i>

The calculated runoff coefficient based on the above for post-development phase is 0.332; refer *Annexure B* for further detail calculations in this regard.

4.2. Time of Concentration

The following formula was used to calculate the time of concentration, which is the time it takes for surface water at the furthest point on the site to reach the lowest area:

$$T_c = \left(\frac{0.87 \times L^2}{1000 \cdot S} \right)^{0.385}$$

Where T_c = Time of Concentration (hours), L = Length of waterway (km), S = average slope.

4.3. Point Intensity

Point Intensity is based on standard time of concentration, and information was extracted from rain fall intensity depth graphs for the area.

4.4. Runoff

4.4.1. PV Area

The runoff distribution of the respective catchment areas will be dictated by the layout of the larger PV area, as well as the internal roads and channels. Each PV area which is a combination of smaller blocks should preferably be orientated in such a way to minimise the impact on natural drainage patterns. A typical PV panel configuration (subject to the final site development plan) is indicated in the *Figure 4.1*, with the resultant drainage pattern in *Figure 4.2* as follows:

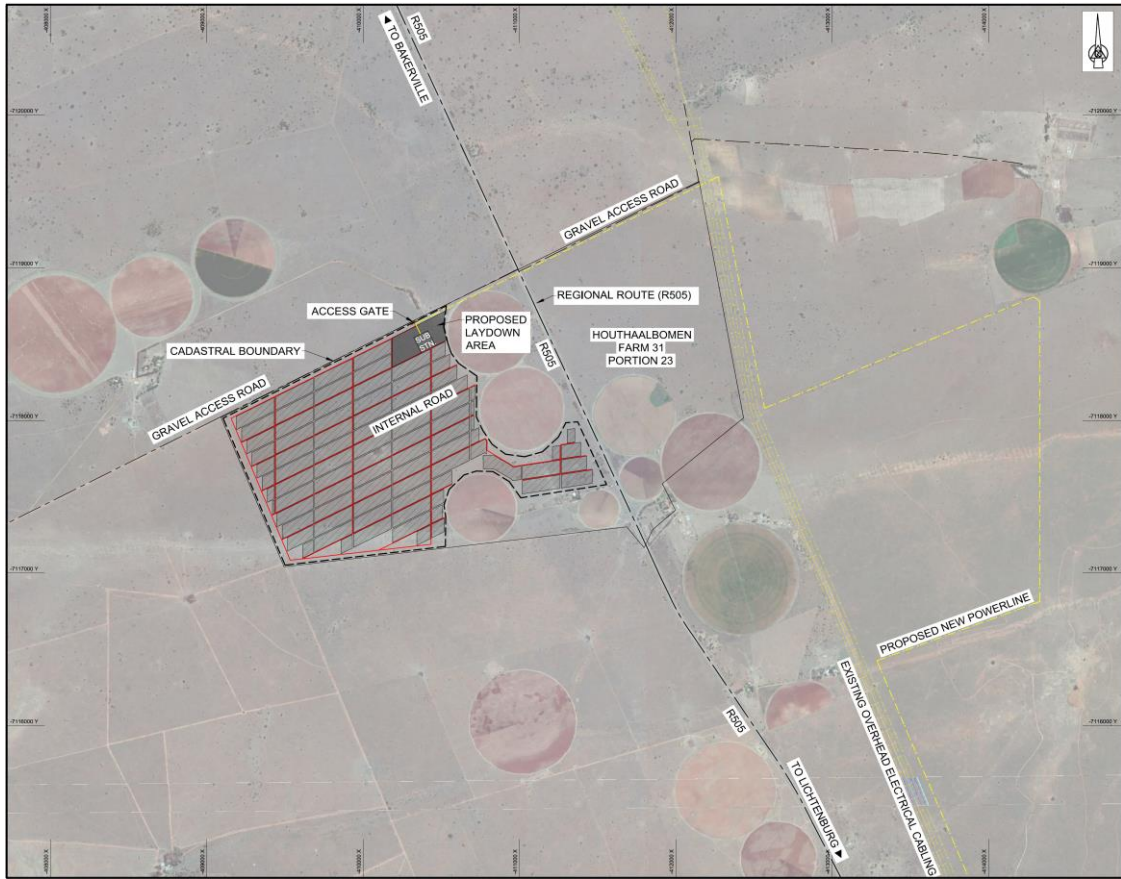

Figure 4.1: Conceptual Layout of PV Panels

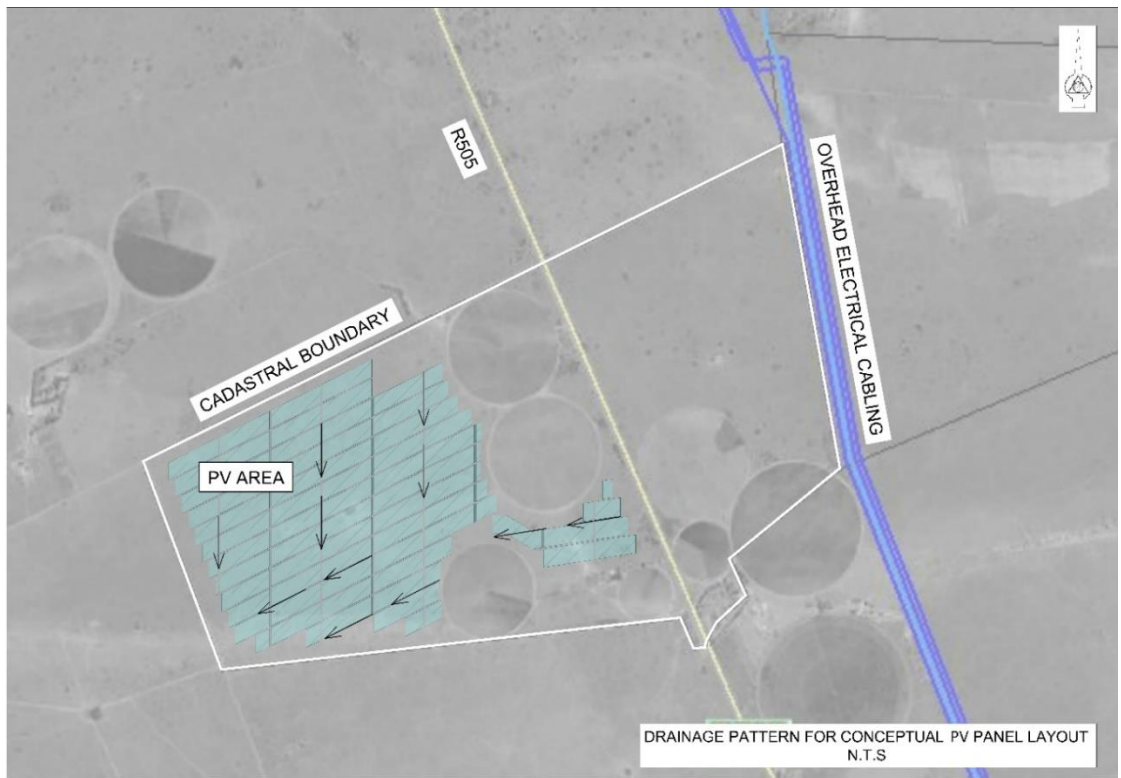

Figure 4.2: Drainage pattern for conceptual layout of PV panels

No waterbodies or places of ponding are visible on the proposed site. There are however the palaeo-river areas, parallel to the southern boundary, within the layout (see Figure 3.3) where water could possibly pond during extended heavy periods of rain and this should be considered during the final detailed design.

The 1:50 year flood occurrence for pre and post-development runoff for the catchment area is shown below:

Catchment Area = 10.06 km²

Pre-Development C = 0.307

Post-Development C = 0.332

TC = 1.79 hours

Intensity = 50.3 mm/hr

$$\text{Rational Method Pre-Development } Q = \frac{CIA}{3.6} = \mathbf{34.58 \text{ m}^3/\text{s}}$$

$$\text{Rational Method Post-Development } Q = \frac{CIA}{3.6} = \mathbf{37.46 \text{ m}^3/\text{s}}$$

4.4.2. Access Roads

As mentioned before, the access road intersects with the R505 (see Figure 4.3) and this road does have sufficient drainage. It is recommended that the first 200m of the access road be upgraded to a hardened (bitumen) surface, to prevent damage to the road edge. This upgrade should allow for sufficient drainage; however, the remainder of the access road will remain gravel and provision must be made for drainage thereof.

The run-off across the gravel road is viewed to be very limited. The flow velocity and depth at the various outlets will have to be confirmed during the detailed design stage. The average velocity is in the order of 1.0 m/s for the gentle slopes on this site (0.3% to 1.4% max). Such flows will not cause any serious erosion, but appropriate measures should be implemented at outlets and points of concentration caused by drainage channels. This will reduce the risk of erosion damage. Frequent nominal drainage measures, typically piped culverts and/or mitre drains cut by a grader,

must be provided at intervals between 200m to 300m as dictated by the site conditions and must be taken care of in the detail design. These could also be in-situ formed drifts where the road alignment is close to the natural ground level.

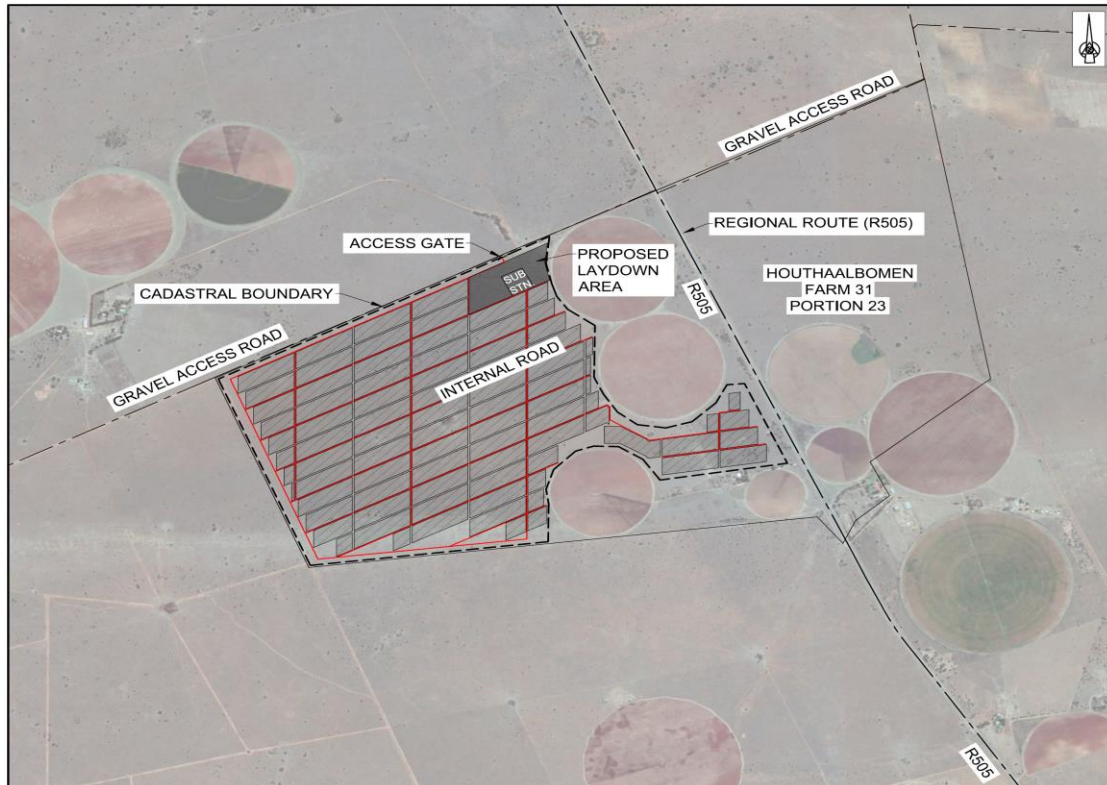

Figure 4.3: Access Roads

5. PROPOSALS FOR STORMWATER MANAGEMENT

The existing drainage patterns and characteristics should be preserved as far as possible. It is therefore suggested that the existing contours and vegetation be retained and that the internal roads are designed and constructed to minimum standards. The runoff calculations indicate that an additional 2.9 m³/s or roughly a 8% increase in peak runoff will have to be accommodated when designing the stormwater management measures.

Drainage structures would include smaller diameter pipes (encased in concrete because of the low fill anticipated) or preferably gravel or concrete drifts. These drifts should have cut-off walls on the down-stream side as a minimum requirement.

5.1. Side Drains

Open drains will be provided along the proposed internal roads or between PV panels. These drains would be gravel drains with concrete or edge beam protection at road crossings where required.

5.2. Berms

Berms are proposed to prevent external stormwater from entering the PV area and for directing flow to suitable areas of release, see *Figure 5.1* for typical berm details. Cut off drains are proposed on the northern property boundary to reduce runoff from the larger catchment area (see Fig 3.3).

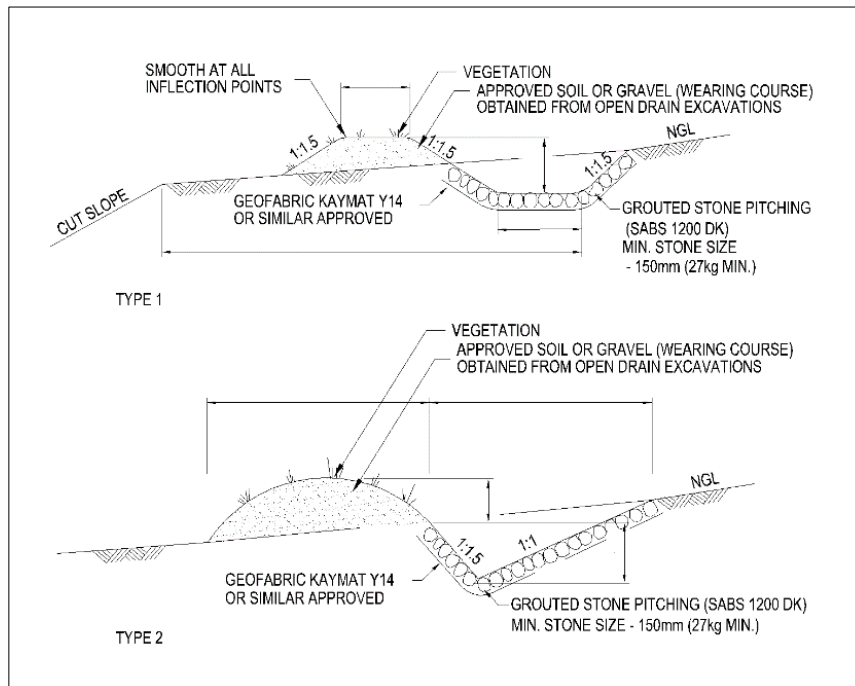

Figure 5.1: Typical Berm Detail

5.3. Outlets

All culverts on the access roads must be provided with concrete outlets with erosion protection. Side drain outlets should be terminated with suitable erosion protection to reduce the velocity and the flow depth.

6. EROSION PROTECTION MEASURES

The volume and velocity of the stormwater runoff must be thoroughly evaluated during the detailed design phase. The following erosion protection measures should be considered:

- Side drains, see *Figure 6.1 and 6.2*
- Inlet and outlet structures, see *Figure 6.3 and 6.4*

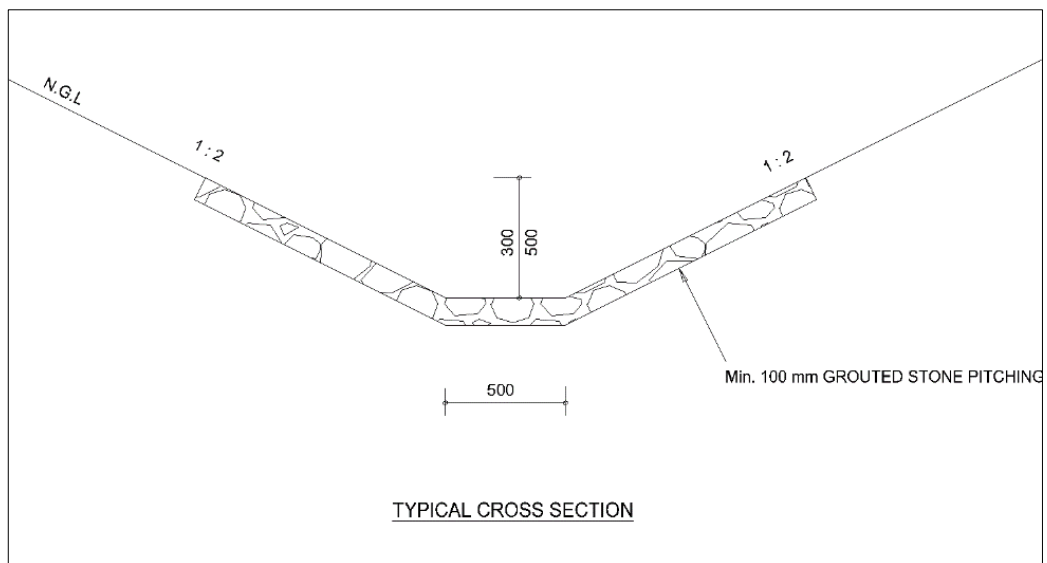

Figure 6.1: Typical Stone Pitched Side Drain

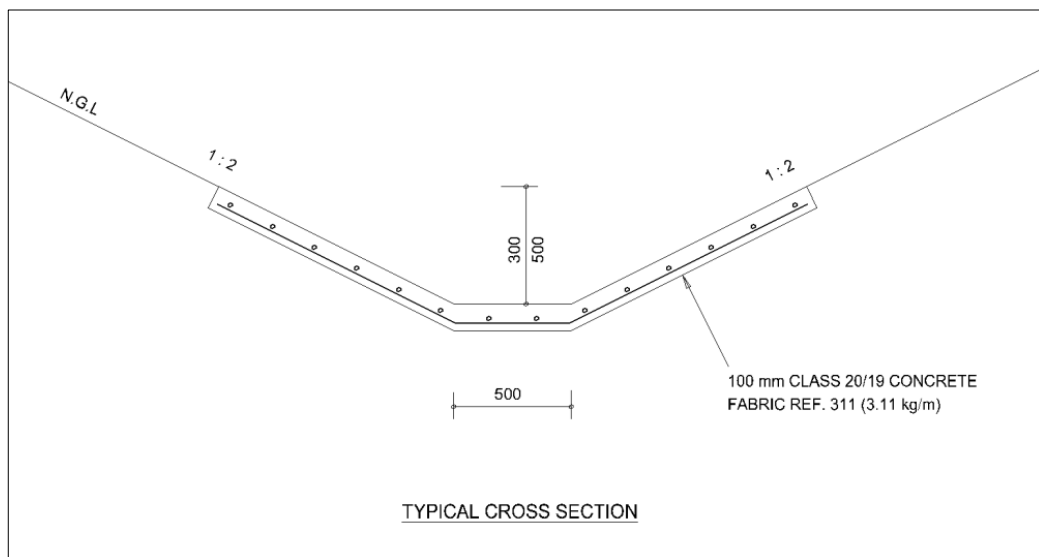

Figure 6.2: Typical Concrete Lined Side Drain

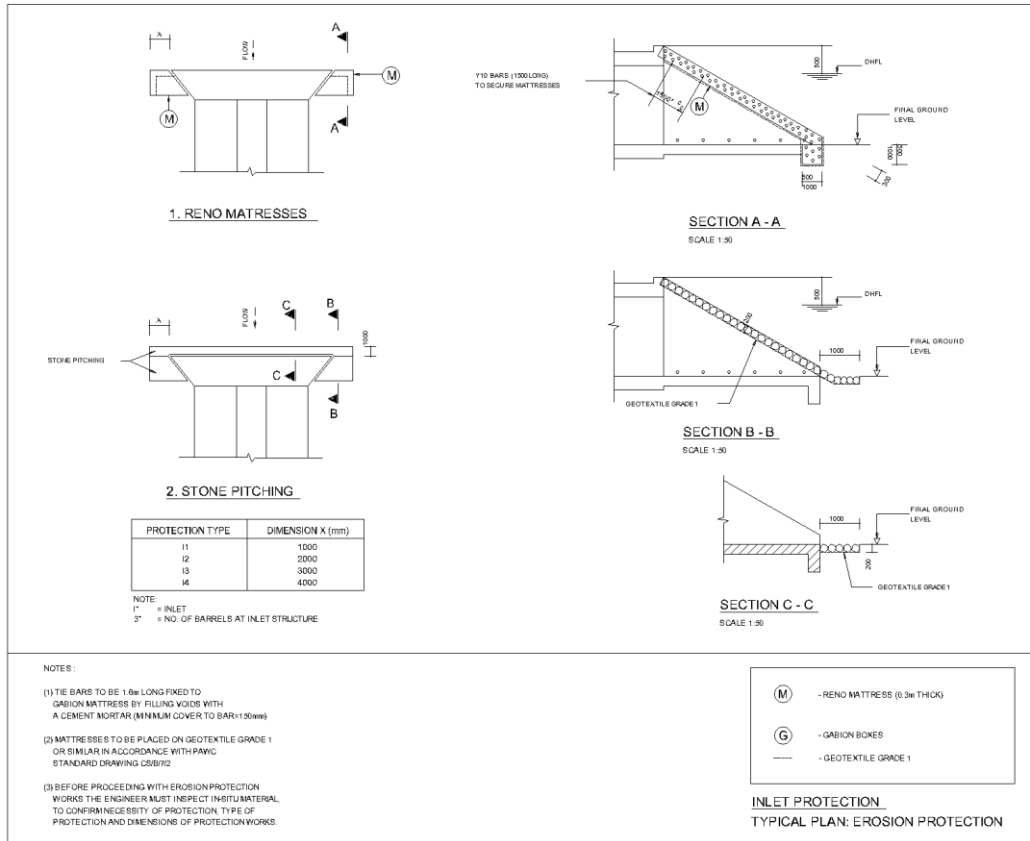

Figure 6.3: Typical inlet erosion protection measures

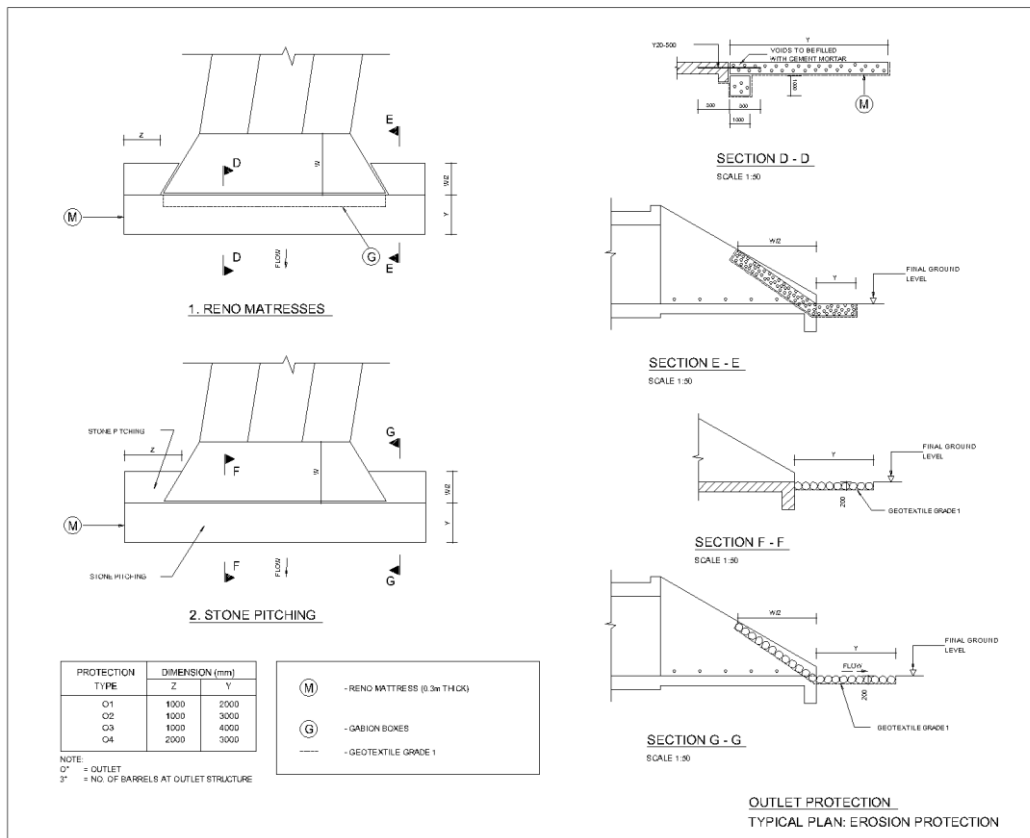

Figure 6.4: Typical outlet erosion protection measures

It is envisaged that in combination with the above the following are also likely to be required:

- Stone masonry walls to reduce the flow velocity in steeper areas;
- Side Drain Outlets with stone pitching to prevent erosion; and
- Temporary berms and straw bales during construction in the vicinity of identified streams to reduce flow and sediment transport during this phase.

During the construction phase special attention must be given to stormwater so that construction activities do not result in any water ponding, especially in the vicinity of the roads and structures.

7. WASTE WATER MANAGEMENT

After the installation of the panels, the cleaning (washing) of the solar panels is likely to cause small amounts of additional runoff. This process is estimated to occur twice a year and add approximately 3l/m² of additional runoff to the site, over a period of approximately 2 weeks. This runoff would however be spread throughout the site, and due to the low localised water volumes would cause minimal, if any, erosion on the site and may even help as a form of dust control. The methods used for washing the panels determine the mitigation measures to be applied. This could be in the form of phasing the washing of panels or optimising the methods used. The overall effect on the site is expected to be very low, provided the cleaning water is free from detergents and includes only approved bio-degradable substances.

Rain will also aid in keeping the PV panels clean. The solar module surfaces are installed at a relatively large incline with gaps between modules. This does not allow significant water build-up on the modules while also reducing the energy generated by the falling rain droplets.

On large structures or buildings appropriate guttering could be used around the building to avoid water erosion where roof water would be flowing off the roof. Wherever practically possible, stormwater run-off from the gutter/roofs will be captured and stored in rainwater tanks. If this water cannot be captured, water will be channelled into energy dissipating structures to spread the water and slow it down to reduce risk of erosion. Such a structure could be constructed from precast concrete or loosely packed rock or perforated bags filled with stone. There is a large amount of loose rock available on site that can be used for this purpose.

8. CONCLUSIONS AND RECOMMENDATIONS

The additional stormwater runoff generated from the new facility post-development is almost negligible compared to pre-development. It is therefore envisaged to do limited stormwater management to reduce the impact of the proposed development on the environment.

By implementing earth drains, lined drains and limited erosion protection structures, the stormwater on the site, between the PV panels and for the adjacent access roads could easily be accommodated safely and in a non-destructive way. The development of the site will also be done in accordance with the existing slopes. The contours will be followed closely in order to minimise impacts on the existing drainage patterns.

9. REFERENCES

- Various Municipal Management of Urban Stormwater Impacts Policies
- The Georgia Stormwater Management Manual
- The South African National Roads Agency Limited. (2006). Drainage Manual Fully Revised 5th Edition
- Adamson P.T. (1983). Technical Report TR 102. Southern African Storm Rainfall
- Savannah environmental: Lichtenburg 2, North West Province, Scoping report, August 2018

10. ANNEXURES

Annexure A: Pre-Development Runoff Calculations

Flood Frequency Analysis: Rational Method

Project = LICHTENBURG PV2
 Analysed by = RdV
 Name of river = N/A
 Description of site = PORTION 23 OF THE FARM HOUTHAAALBOOMEN NO. 31 : PRE-DEVELOPED
 Date = 2018/10/03
 Area of catchment = 10.058 km²
 Dolomitic area = 20.0 %
 Mean annual rainfall (MAR) = 586.00 mm
 Length of longest watercourse = 3.967 km
 Flow of water = Overland flow
 Height difference = 6.0 m
 Value of r for over land flow = Clean soil (r=0,1)
 Rainfall region = Inland
 Area distribution = Rural: 100 %, Urban: 0 %, Lakes: 0 %

Catchment description - Urban area (%)

Lawns		Residential and industry	Business	
Sandy, flat (<2%)	0	Houses	City centre	0
Sandy, steep (>7%)	0	Flats	Suburban	0
Heavy soil, flat (<2%)	0	Light industry	Streets	0
Heavy soil, steep (>7%)	0	Heavy industry	Maximum flood	0

Catchment description - Rural area (%)

Surface slopes		Permeability	Vegetation	
Lakes and pans	0	Very permeable	Thick bush & forests	0
Flat area	80	Permeable	Light bush & cultivated land	30
Hilly	20	Semi-permeable	Grasslands	70
Steep areas	0	Impermeable	Bare	0

Average slope = 0.00151 m/m
 Time of concentration = 1.79 h
 Run-off factor
 Rural - C1 = 0.307
 Urban - C2 = 0.000
 Lakes - C3 = 0.000
 Combined - C = 0.259

Rural run-off coefficient C1 above includes dolomitic factors where applicable.

The HRU, Report 2/78, Depth-Duration-Frequency diagram was used to determine the point rainfall.

Return Period (years)	Time of concentration (hours)	Point rainfall (mm)	ARF (%)	Average intensity (mm/h)	Factor Ft	Runoff coefficient (%)	Peak flow (m ³ /s)
1:20	1.79	70.0	98.9	38.8	0.90	23.3	25.29
1:50	1.79	91.1	98.6	50.3	0.95	24.6	34.58
1:100	1.79	112.1	98.3	61.6	1.00	25.9	44.66

Run-off coefficient percentage includes adjustment saturation factors (Ft) for steep and impermeable catchments

Calculated using Utility Programs for Drainage 1.1.0

Annexure B: Post-Development Runoff Calculations

Flood Frequency Analysis: Rational Method

Project = LICHTENBURG PV2
 Analysed by = RdV
 Name of river = N/A
 Description of site = PORTION 23 OF THE FARM HOUTHAALBOOMEN NO. 31 : POST-DEVELOPED
 Date = 2018/10/03
 Area of catchment = 10.058 km²
 Dolomitic area = 20.0 %
 Mean annual rainfall (MAR) = 586.00 mm
 Length of longest watercourse = 3.967 km
 Flow of water = Overland flow
 Height difference = 6.0 m
 Value of r for over land flow = Clean soil (r=0,1)
 Rainfall region = Inland
 Area distribution = Rural: 100 %, Urban: 0 %, Lakes: 0 %

Catchment description - Urban area (%)

Lawns	Residential and industry	Business
Sandy, flat (<2%) 0	Houses 0	City centre 0
Sandy, steep (>7%) 0	Flats 0	Suburban 0
Heavy soil, flat (<2%) 0	Light industry 0	Streets 0
Heavy soil, steep (>7%) 0	Heavy industry 0	Maximum flood 0

Catchment description - Rural area (%)

Surface slopes	Permeability	Vegetation
Lakes and pans 0	Very permeable 0	Thick bush & forests 0
Flat area 80	Permeable 45	Light bush & cultivated land 30
Hilly 20	Semi-permeable 45	Grasslands 50
Steep areas 0	Impermeable 10	Bare 20

Average slope = 0.00151 m/m

Time of concentration = 1.79 h

Run-off factor

Rural - C1 = 0.332

Urban - C2 = 0.000

Lakes - C3 = 0.000

Combined - C = 0.281

Rural run-off coefficient C1 above includes dolomitic factors where applicable.

The HRU, Report 2/78, Depth-Duration-Frequency diagram was used to determine the point rainfall.

Return Period (years)	Time of concentration (hours)	Point rainfall (mm)	ARF (%)	Average intensity (mm/h)	Factor Ft	Runoff coefficient (%)	Peak flow (m ³ /s)
1:20	1.79	70.0	98.9	38.8	0.90	25.3	27.39
1:50	1.79	91.1	98.6	50.3	0.95	26.7	37.46
1:100	1.79	112.1	98.3	61.6	1.00	28.1	48.37

Run-off coefficient percentage includes adjustment saturation factors (Ft) for steep and impermeable catchments

Calculated using Utility Programs for Drainage 1.1.0

**Appendix H:
Waste Management Plan**

WASTE MANAGEMENT PLAN

1. PURPOSE

A Waste Management Plan (WMP) plays a key role in achieving sustainable waste management throughout all phases of the project. The plan prescribes measures for the collection, temporary storage and safe disposal of the various waste streams associated with the project and includes provisions for the recovery, re-use and recycling of waste. The purpose of this plan is therefore to ensure that effective procedures are implemented for the handling, storage, transportation and disposal of waste generated from the project activities on site.

This WMP has been compiled as part of the project EMPr and is based on waste stream information available at the time of compilation. Construction and operation activities must be assessed on an ongoing basis in order to determine the efficacy of the plan and whether further revision of the plan is required. This plan should be updated should further detail regarding waste quantities and categorisation become available, during the construction and/or operation stages.

2. RELEVANT ASPECTS OF THE SITE

It is expected that the development of Lichtenburg 2 will generate construction solid waste, general waste and hazardous waste during the lifetime of the PV facility.

Waste generated on site, originates from various sources, including but not limited to:

- » Concrete waste generated from spoil and excess concrete.
- » Contaminated water, soil, rocks and vegetation due to hydrocarbon spills.
- » Hazardous waste from vehicle, equipment and machinery parts and servicing, fluorescent tubes, used hydrocarbon containers, and waste ink cartridges.
- » Recyclable waste in the form of paper, glass, steel, aluminium, wood/ wood pallets, plastic (PET bottles, PVC, LDPE) and cardboard.
- » Organic waste from food waste as well as alien and endemic vegetation removal.
- » Sewage from portable toilets and septic tanks.
- » Inert waste from spoil material from site clearance and trenching works.

3. LEGISLATIVE REQUIREMENTS

Waste in South Africa is currently governed by several regulations, including:

- » National Environmental Management: Waste Act (NEM:WA), 2008 (Act 59 of 2008);
- » National Environmental Management: Waste Amendment Act, 2014 (Act 26 of 2014);
- » The South African Constitution (Act 108 of 1996);
- » Hazardous Substances Act (Act 5 of 1973);
- » Health Act (Act 63 of 1977);
- » Environment Conservation Act (Act 73 of 1989);
- » Occupational Health and Safety Act (Act 85 of 1993);
- » National Water Act (Act 36 of 1998);
- » The National Environmental Management Act (Act 107 of 1998) (as amended);

- » Municipal Structures Act (Act 117 of 1998);
- » Municipal Systems Act (Act 32 of 2000);
- » Mineral and Petroleum Resources Development Act (Act 28 of 2002); and
- » Air Quality Act (Act 39 of 2004).

Storage of waste must be conducted in accordance with the National Norms and Standards for the Storage of Waste, published in GNR 926.

4. WASTE MANAGEMENT PRINCIPLES

An integrated approach to waste management is needed on site. Such an approach is illustrated in **Figure 1**.

It is important to ensure that waste is managed with the following objectives in mind during all phases of the project:

- » Reducing volumes of waste is the greatest priority;
- » If reduction is not feasible, the maximum amount of waste is to be recycled; and
- » Waste that cannot be recycled is to be disposed of in the most environmentally responsible manner.

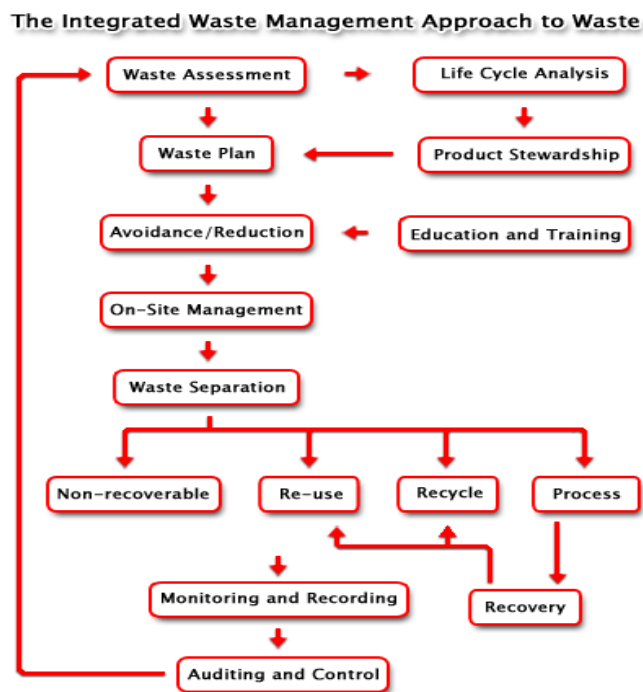

Figure 1: Integrated Waste Management Flow Diagram

(Source: <http://www.enviroserv.co.za/pages/content.asp?SectionId=496>)

4.1. Construction phase

A plan for the management of waste during the construction phase is detailed below. A Method Statement detailing specific waste management practices during construction should be prepared by the Contractor prior to the commencement of construction, for approval by the Resident Engineer and/or ECO.

4.1.1. Waste Assessment / Inventory

- » The Environmental Officer (EO), or designated staff member, must develop, implement and maintain a waste inventory reflecting all waste generated during construction for both general and hazardous waste streams.
- » Construction methods and materials should be carefully considered in view of waste reduction, re-use, and recycling opportunities, to be pro-actively implemented.
- » Once a waste inventory has been established, targets for the recovery of waste (minimisation, re-use, recycling) should be set.
- » The EO must conduct waste classification and rating in terms of SANS 10288 and Government Notice 634 published under the NEM: WA.

4.1.2. Waste collection, handling and storage

- » It is the responsibility of the EO to ensure that each subcontractor implements their own waste recycling system, i.e. separate bins for food waste, plastics, paper, wood, glass, cardboard, metals, etc. Such practises must be made contractually binding upon appointment of the subcontractors.
- » Waste manifests and waste acceptance approvals (i.e. receipts) from designated waste facilities must be kept on file at the site office, in order to record and prove continual compliance for future auditing.
- » Septic tanks and portable toilets must be monitored by the EO or responsible subcontractor and maintained regularly. Below ground storage of septic tanks must withstand the external forces of the surrounding environment. The area above the tank must be demarcated to prevent any vehicles or heavy machinery from moving around in the surrounding area.
- » Waste collection bins and hazardous waste containers must be provided by the principal contractor and subcontractors and placed at strategic locations around the site for the storage of organic, recyclable and hazardous waste.
- » A dedicated waste area must be established on site for the storage of all waste streams before removal from site. The storage period must not trigger listed waste activities as per the NEMWA, GN 921 of November 2013.
- » Signage/ colour coding must be used to differentiate disposal areas for the various waste streams (i.e. paper, cardboard, metals, food waste, glass etc.).
- » Hazardous waste must be stored within a bunded area constructed according to SABS requirements, and must ensure complete containment of the spilled material in the event of a breach. As such, appropriate bunding material, design, capacity and type must be utilised to ensure that no contamination of the surrounding environment will occur despite a containment breach. The net capacity of a bunded compound in a storage facility should be at least 120% of the net capacity of the largest tank.
- » Take into consideration the capacity displaced by other tanks within the same bunded area and any foundations.

- » Treat interconnected tanks as a single tank of equivalent total volume for the purposes of the bund design criteria.
- » The location of all temporary waste storage areas must aim to minimise the potential for impact on the surrounding environment, including prevention of contaminated runoff, seepage, and vermin control, while being reasonably placed in terms of centrality and accessibility on site. Where required, an additional temporary waste storage area may be designated, provided identical controls are exercised for these locations.
- » Waste storage shall be in accordance with all Regulations and best-practice guidelines and under no circumstances may waste be burnt on site.
- » A dedicated waste management team must be appointed by the principal contractors' SHE Officer, who will be responsible for ensuring the continuous sorting of waste and maintenance of the area. The waste management team must be trained in all areas of waste management and monitored by the SHE Officer.
- » All waste removed from site must be done by a registered/ licensed subcontractor, who must supply information regarding how waste recycling/ disposal will be achieved. The registered subcontractor must provide waste manifests for all removals at least once a month or for every disposal made, records of which must be kept on file at the site camp for the duration of the construction period.

4.1.3. Management of waste storage areas

- » The position of all waste storage areas must be located so as to ensure minimal degradation to the environment. The main waste storage area must have a suitable stormwater system separating clean and contaminated stormwater.
- » Collection bins placed around the site and at subcontractors' camps (if at a different location than the main site camp) must be maintained and emptied on a regular basis by the principal contractor to avoid overflowing receptacles.
- » Inspections and maintenance of the main waste storage area must be undertaken daily. Skips and storage containers must be clearly marked or colour coded and well-maintained. Monitor for rodents and take corrective action if they become a problem.
- » Waste must be stored in designated containers and not on the ground.
- » Inspections and maintenance of bunds must be undertaken regularly. Bunds must be inspected for leaks or cracks in the foundation and walls.
- » It is assumed that any rainwater collected inside the bund is contaminated and must be treated by oil/water separation (or similar method) prior to dewatering, or removed and stored as hazardous waste, and not released into the environment.
- » If any leaks occur in the bund, these must be amended immediately.
- » Bund systems must be designed to avoid dewatering of contaminated water, but to rather separate oil and hydrocarbons from water prior to dewatering.
- » Following rainfall events bunds must always be dewatered in order to maintain a sufficient storage capacity in the event of a breach.
- » No mixing of hazardous and general waste is allowed.

4.1.4. Disposal

- » Waste generated on site must be removed on a regular basis. This frequency may change during construction depending on waste volumes generated at different stages of the construction process,

however removal must occur prior to the storage capacity being reached to avoid overflow of containers and poor waste storage.

- » Waste must be removed by a suitably qualified contractor and disposed of at an appropriately licensed landfill site. Proof of appropriate disposal must be provided by the contractor to the EO and ECO.

4.1.5. Record keeping

The success of the Waste Management Plan is determined by measuring criteria such as waste volumes, cost recovery from recycling and cost of disposal. Recorded data can indicate the effect of training and education, or the need for education. It will provide trends and benchmarks for setting goals and standards. It will provide clear evidence of the success or otherwise of the plan.

- » Documentation (waste manifest, certificate of issue or safe disposal) must be kept detailing the quantity, nature, and fate of any regulated waste for audit purposes.
- » Waste management must form part of the monthly reporting requirements in terms of volumes generated, types, storage and final disposal.

4.1.6. Training

Training and awareness regarding waste management shall be provided to all employees and contractors as part of the toolbox talks or on-site awareness sessions with the EO and at the frequency as set out by the ECO.

4.2. Operation phase

It is expected that the operation phase will result in the production of limited amounts of general waste consisting mostly of cardboard, paper, plastic, tins, metals and a variety of synthetic compounds. Hazardous wastes (including grease, oils) will also be generated. All waste generated will be required to be temporarily stored at the facility in appropriate sealed containers prior to disposal at a permitted landfill site or other facilities.

The following waste management principles apply during the operation phase:

- » The SHE Manager must develop, implement and maintain a waste inventory reflecting all waste generated during operation for both general and hazardous waste streams.
- » Adequate waste collection bins at site must be supplied. Separate bins should be provided for general and hazardous waste.
- » Recyclable waste must be removed from the waste stream and stored separately.
- » All waste must be stored in appropriate temporary storage containers (separated between different operation wastes, and contaminated or wet waste).
- » Waste storage shall be in accordance with all best-practice guidelines and under no circumstances may waste be burnt on site.
- » Waste generated on site must be removed on a regular basis throughout the operation phase.
- » Waste must be removed by a suitably qualified contractor and disposed of at an appropriately licensed landfill site. Proof of appropriate disposal must be provided by the contractor and kept on site.

5. Monitoring of Waste Management Activities

Records must be kept of the volumes/ mass of the different waste streams that are collected from the site throughout the life of the project. The appointed waste contractor is to provide monthly reports to the operator containing the following information:

- » Monthly volumes/ mass of the different waste streams collected;
- » Monthly volumes/ mass of the waste that is disposed of at a landfill site;
- » Monthly volumes/ mass of the waste that is recycled;
- » Data illustrating progress compared to previous months.

This report will aid in monitoring the progress and relevance of the waste management procedures that are in place. If it is found that the implemented procedures are not as effective as required, this WMP is to be reviewed and amended accordingly. This report must form part of the EO's reports to the ECO on a monthly basis.

Appendix I:
Emergency Preparedness, Response and Fire Management Plan

EMERGENCY PREPAREDNESS, RESPONSE AND FIRE MANAGEMENT PLAN

1. PURPOSE

The purpose of the Emergency Preparedness and Response Plan is:

- » To assist contractor personnel to prepare for and respond quickly and safely to emergency incidents, and to establish a state of readiness which will enable prompt and effective responses to possible events.
- » To control or limit any effect that an emergency or potential emergency may have on site or on neighbouring areas.
- » To facilitate emergency responses and to provide such assistance on the site as is appropriate to the occasion.
- » To ensure communication of all vital information as soon as possible.
- » To facilitate the reorganisation and reconstruction activities so that normal operations can be resumed.
- » To provide for training so that a high level of preparedness can be continually maintained.

This plan outlines response actions for potential incidents of any size. It details response procedures that will minimise potential health and safety hazards, environmental damage, and clean-up efforts. The plan has been prepared to ensure quick access to all the information required in responding to an emergency event. The plan will enable an effective, comprehensive response to prevent injury or damage to the construction personnel, public, and environment during the project. Contractors are expected to comply with all procedures described in this document. A Method Statement should be prepared at the commencement of the construction phase detailing how this plan is to be implemented as well as details of relevant responsible parties for the implementation. The method statement must also reflect conditions of the IFC Performance Standard 1 and include the following:

- » Identification of areas where accidents and emergency situations may occur;
- » Communities and individuals that may be impacted;
- » Response procedure;
- » Provisions of equipment and resources;
- » Designation of responsibilities;
- » Communication; and
- » Periodic training to ensure effective response to potentially affected communities.

2. PROJECT-SPECIFIC DETAILS

ABO Wind Lichtenburg 2 PV (Pty) Ltd proposes the development of Lichtenburg 2, a PV facility and associated infrastructure on a site near Lichtenburg, in the North West Province. Lichtenburg 2 will be designed to have a contracted capacity of up to 100MW, and will make use of photovoltaic (PV) solar technology. The project will comprise the following key infrastructure and components:

- » Arrays of PV solar panels with a contracted capacity of up to 100MW.
- » Mounting structures to support the PV panels (utilising either fixed-tilt / static, single-axis tracking, or double-axis tracking systems).

- » On-site inverters to convert power from Direct Current (DC) to Alternating Current (AC), and a 132kV on-site substation to facilitate the connection between the solar facility and the Eskom grid connection point.
- » A new 132kV power line between the on-site substation and the Eskom grid connection point.
- » Cabling between the project's components, to be laid underground where practical.
- » Auxiliary buildings such as offices and workshop areas for maintenance and storage.
- » Temporary laydown areas required during construction.
- » Internal access roads and perimeter security fencing around the development area.

Due to the scale and nature of this development, it is anticipated that the following risks could potentially arise during the construction and operation phases:

- » Fires;
- » Leakage of hazardous substances;
- » Storage of flammable materials and substances;
- » Flood events;
- » Accidents; and
- » Natural disasters.

3. EMERGENCY RESPONSE PLAN

There are three levels of emergency as follows:

- » Local Emergency: An alert confined to a specific locality.
- » Site Emergency: An alert that cannot be localised and which presents danger to other areas within the site boundary or outside the site boundary.
- » Evacuation: An alert when all personnel are required to leave the affected area and assemble in a safe location.

If there is any doubt as to whether any hazardous situation constitutes an emergency, then it must be treated as an Evacuation.

Every effort must be made to control, reduce or stop the cause of any emergency provided it is safe to do so. For example, in the event of a fire, isolate the fuel supply and limit the propagation of the fire by cooling the adjacent areas. Then confine and extinguish the fire (where appropriate) making sure that re-ignition cannot occur.

3.1. Emergency Scenario Contingency Planning

3.1.1. Scenario: Spill which would result in the contamination of land, surface or groundwater

i. Spill Prevention Measures

Preventing spills must be the top priority at all operations which have the potential of endangering the environment. The responsibility to effectively prevent and mitigate any scenario lies with the Contractor and the ECO. In order to reduce the risk of spills and associated contamination, the following principles should be considered during construction and operation activities:

- » All equipment refuelling, servicing and maintenance activities should only be undertaken within appropriately sealed/contained or bunded designated areas.
- » All maintenance materials, oils, grease, lubricants, etc. should be stored in a designated area in an appropriate storage container.
- » No refuelling, storage, servicing, or maintenance of equipment should take place within sensitive environmental resources in order to reduce the risk of contamination by spills.
- » No refuelling or servicing should be undertaken without absorbent material or drip pans properly placed to contain spilled fuel.
- » Any fluids drained from the machinery during servicing should be collected in leak-proof containers and taken to an appropriate disposal or recycling facility.
- » If these activities result in damage or accumulation of product on the soil, the contaminated soil must be disposed of as hazardous waste. Under no circumstances shall contaminated soil be added to a spoils pile and transported to a regular disposal site.
- » Chemical toilets used during construction must be regularly cleaned. Chemicals used in toilets are also hazardous to the environment and must be controlled. Portable chemical toilets could overflow if not pumped regularly or they could spill if dropped or overturned during moving. Care and due diligence should be taken at all times.
- » Contact details of emergency services and HazMat Response Contractors are to be clearly displayed on the site. All staff are to be made aware of these details and must be familiar with the procedures for notification in the event of an emergency.

ii. Procedures

The following action plan is proposed in the event of a spill:

1. Spill or release identified.
2. Assess person safety, safety of others and environment.
3. Stop the spill if safely possible.
4. Contain the spill to limit entering surrounding areas.
5. Identify the substance spilled.
6. Quantify the spill (under or over guideline/threshold levels).
7. Notify the Site Manager and emergency response crew and authorities (in the event of major spill).
8. Inform users (and downstream users) of the potential risk.
9. Clean up of the spill using spill kit or by HazMat team.
10. Record of the spill incident on company database.

a) **Procedures for containing and controlling the spill (i.e. on land or in water)**

Measures can be taken to prepare for quick and effective containment of any potential spills. Each contractor must keep sufficient supplies of spill containment equipment at the construction sites, at all times during and after the construction phase. These should include specialised spill kits or spill containment equipment. Other spill containment measures include using drip pans underneath vehicles and equipment every time refuelling, servicing, or maintenance activities are undertaken.

Specific spill containment methods for land and water contamination are outlined below.

Containment of Spills on Land

Spills on land include spills on rock, gravel, soil and/or vegetation. It is important to note that soil is a natural sorbent, and therefore spills on soil are generally less serious than spills on water as contaminated soil can be more easily recovered. It is important that all measures be undertaken to avoid spills reaching open water bodies located outside of the project site. The following methods could be used:

- » *Dykes* - Dykes can be created using soil surrounding a spill on land. These dykes are constructed around the perimeter or down slope of the spilled substance. A dyke needs to be built up to a size that will ensure containment of the maximum quantity of contaminant that may reach it. A plastic tarp can be placed on and at the base of the dyke such that the contaminant can pool up and subsequently be removed with sorbent materials or by pump into barrels or bags. If the spill is migrating very slowly, a dyke may not be necessary and sorbents can be used to soak up contaminants before they migrate away from the source of the spill.
- » *Trenches* - Trenches can be dug out to contain spills. Spades, pick axes or a front-end loader can be used depending on the size of the trench required. Spilled substances can then be recovered using a pump or sorbent materials.

b) Procedures for transferring, storing, and managing spill related wastes

Used sorbent materials are to be placed in plastic bags for future disposal. All materials mentioned in this section are to be available in the spill kits. Following clean up, any tools or equipment used must be properly washed and decontaminated, or replaced if this is not possible.

Spilled substances and materials used for containment must be placed into empty waste oil containers and sealed for proper disposal at an approved disposal facility.

c) Procedures for restoring affected areas

Criteria that may be considered include natural biodegradation of oil, replacement of soil and revegetation. Once a spill of reportable size has been contained, the ECO and the relevant Authority must be consulted to confirm that the appropriate clean up levels are met.

3.1.2. Scenario: Fire (and fire water handling)

i. Action Plan

The following action plan is proposed in the event of a fire:

1. Quantify risk.
2. Assess person safety, safety of others and environment.
3. If safe – attempt to extinguish the fire using appropriate equipment.
4. If not safe to extinguish, contain fire.
5. Notify the Site Manager and emergency response crew and authorities.
6. Inform users of the potential risk of fire.
7. Record the incident on the company database or filing register.

ii. Procedures

Because large scale fires may spread very fast it is most advisable that the employee/contractor not put his/her life in danger in the case of an uncontrolled fire.

Portable firefighting equipment must be provided at strategic locations throughout the site, in line with the Building Code of South Africa and the relevant provincial building code. All emergency equipment including portable fire extinguishers, hose reels and hydrants must be maintained and inspected by a qualified contractor in accordance with the relevant legislation and national standards.

Current evacuation signs and diagrams for the building or site that are compliant to relevant state legislation must be provided in a conspicuous position, on each evacuation route. Contact details for the relevant emergency services should be clearly displayed on site and all employees should be aware of procedures to follow in the case of an emergency.

a) Procedures for initial actions

Persons should not fight the fire if any of the following conditions exist:

- » They have not been trained or instructed in the use of a fire extinguisher.
- » They do not know what is burning.
- » The fire is spreading rapidly.
- » They do not have the proper equipment.
- » They cannot do so without a means of escape.
- » They may inhale toxic smoke.

b) Reporting procedures

In terms of the requirements of NEMA, the responsible person must, within 14 days of the incident, report to the Director General, provincial head of department and municipality.

- » Report fire immediately to the site manager, who will determine if it is to be reported to the relevant emergency services and authorities.
- » The site manager must have copies of the Report form to be completed.

SUMMARY: RESPONSE PROCEDURE

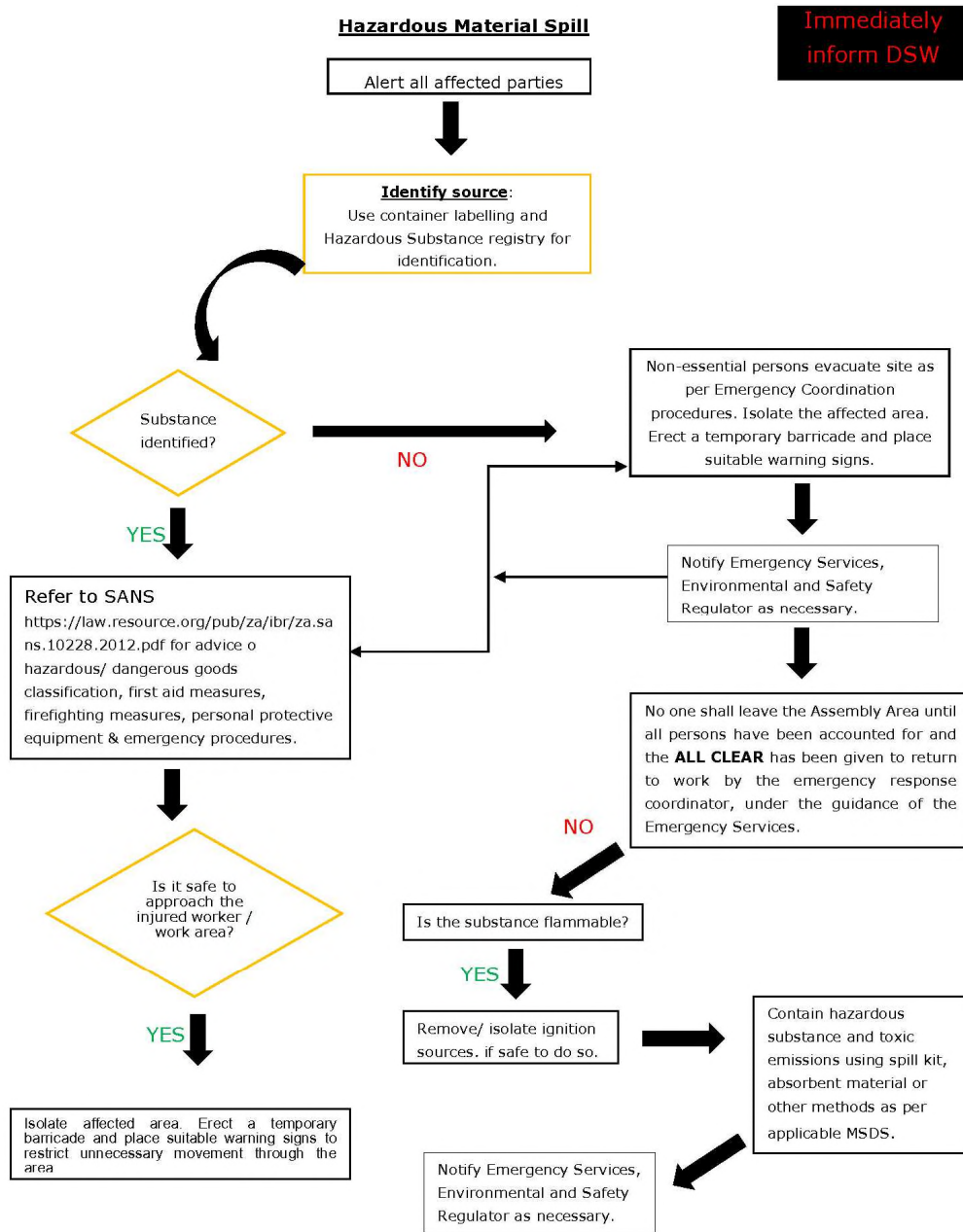

Figure 1: Hazardous Material Spill

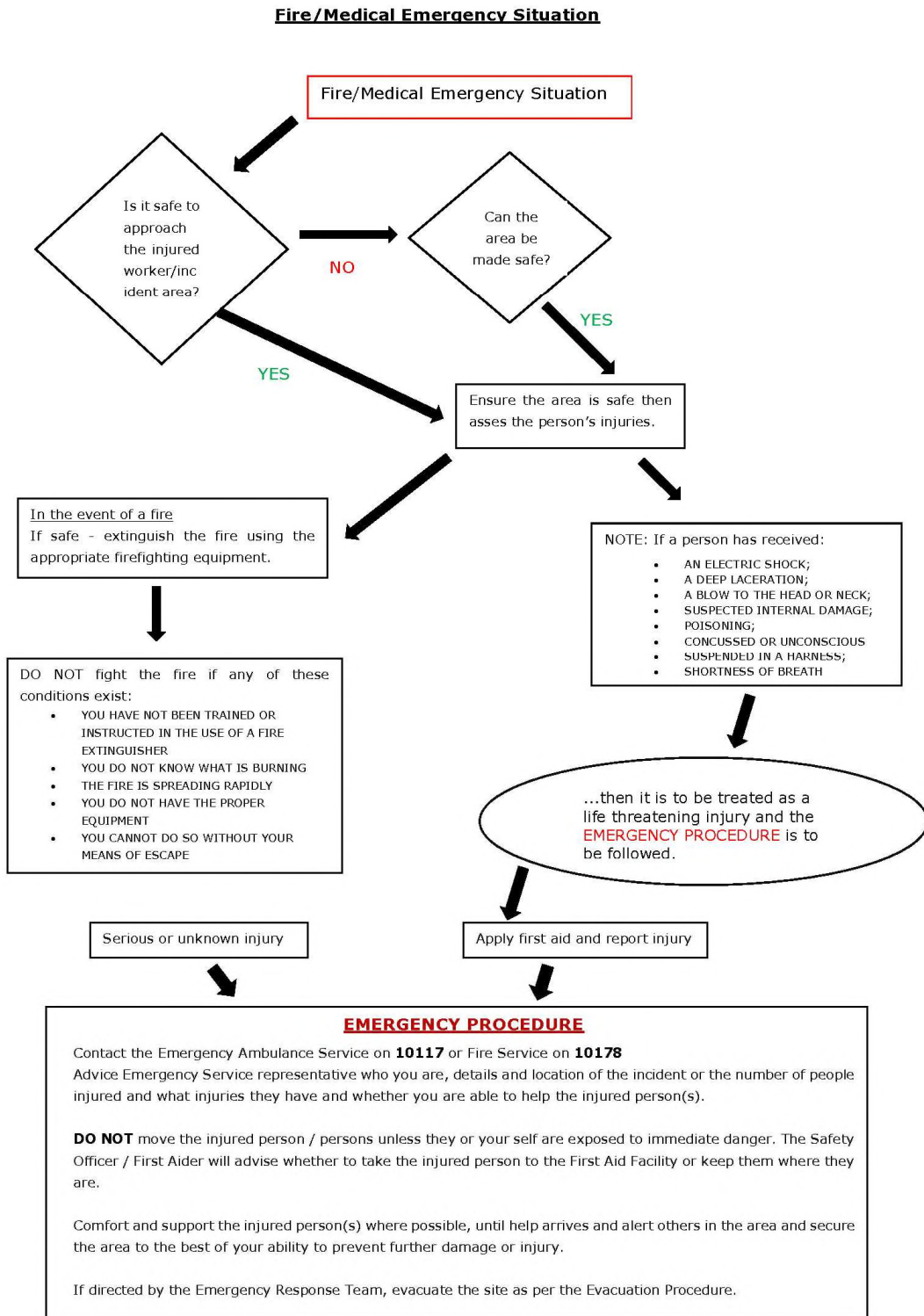

Figure 2: Emergency Fire/Medical

4. PROCEDURE RESPONSIBILITY

The Contractor's Safety, Health and Environment (SHE) Representative, employed by the Contractor, is responsible for managing the day-to-day on-site implementation of this Plan, and for the compilation of regular (usually weekly) Monitoring Reports. In addition, the SHE must act as liaison and advisor on all environmental and related issues.

The local authorities will provide their assistance when deemed necessary, or when it has been requested and/or indicated in Section 30 (8) of NEMA. The provincial authority will provide assistance and guidance where required and conduct awareness programmes.

**Appendix J:
Curriculum Vitae**

CURRICULUM VITAE OF KHOMOTJO REUBEN MAROGA

Profession :	Environmental Consultant
Specialisation:	Environmental Impact Assessments, Basic Assessments, Site Visits, Compilation of Environmental Management Programmes and Liaison with authorities
Work Experience:	3 years of experience in the environmental management field

VOCATIONAL EXPERIENCE

Khomotjo Reuben Maroga has two years of experience in the environmental field. He has worked on a mining infrastructure project in compiling environmental control officer's reports and conducting air and groundwater monitoring using the DustTrak DRX Aerosol Monitor and a Bailer as apparatuses. Additionally, he has provided assistance to Eco-Elementum & Engineering on WUL applications and EIAs.

SKILLS BASE AND CORE COMPETENCIES

- Environmental Impact Assessments
- Compliance Monitoring
- Project Management

EDUCATION AND PROFESSIONAL STATUS

Degrees:

- B.Sc. (Hons) Geology, University of Johannesburg, 2016
- B.Sc. Geology and Environmental Management, University of Johannesburg, 2015

Courses:

- Business Communication, ProEarth Learning Academy (Pty) in Middelburg (2018)
- Describe the functions of a Health and Safety representative, Elite Training (Pty) Ltd in Middelburg (2017)
- Basic Fire Fighting, Elite Training (Pty) Ltd in Middelburg (2017)
- Combined OSHAS 18001: 2007 and ISO 14001: 2015 Introduction, NOSA in eMalahleni (2017)
- Combined OSHAS 18001: 2007 and ISO 14001: 2015 Implementation (2017), NOSA in eMalahleni (2017)
- Emotional Intelligence, LearnMe (Pty) Ltd in Middelburg (2017)

EMPLOYMENT

Date	Company	Roles and Responsibilities
October 2018 - current	Savannah Environmental (Pty) Ltd	<p>Environmental Consultant</p> <p><i>Tasks include:</i> Applying applicable legislation, research of related environmental policy documentation required for EIAs, efficient and quality report writing, liaison with relevant environmental authorities, site visits, compilation of application forms, environmental management programmes (EMPrs) and public participation include documentation. Other related tasks include undertaking water use license applications, environmental auditing (Environmental Control Officer – ECO work) and any other related authorisation, permitting and licensing tasks (on an as and when required basis).</p>
September 2016 - October 2018	Yoctolux Collieries (Pty) Ltd	<p>Environmental Management Intern</p> <p><i>Tasks included:</i> Drafting monthly ECO reports, conducting monthly environmental monitoring, providing assistance on WULAs and EIAs to Eco-Elementum & Engineering (Pty) Ltd and providing oversight on IAPs eradication and management programme.</p>
January – September 2016	University of Johannesburg Auckland Park, Kingsway Campus	<p>Second-year Practical Demonstrator</p> <p><i>Tasks included:</i> Marking of practical's, attending to any ad-hoc administrative duties and liaising with designated lecturers.</p>

PROJECT EXPERIENCE

Mining Projects: Coal Mining

Water Use Licence Application

Project Name & Location	Client Name	Role
Compiling a water use licence report for an underground coal mining development (Tala Bethal Coal) in Hendrina, Mpumalanga.	Diepsoils Investments (Pty) Ltd Vernon Siemelink: 072 196 9928	Assistant

Basic Assessments

Wastewater Treatment Projects

Project Name & Location	Client Name	Role
Kriel Power Station Lime Plant Upgrade, Kriel, Mpumalanga	Eskom Holdings SOC Limited Khuliso Rasimphi : 017 615 2634	Junior EAP
Matla Power Station Reverse Osmosis Plant, Mpumalanga	Eskom Holdings SOC Limited Refilwe Mokobodi, 017 612 6263 / 072 997 8780	EAP

Renewable Energy

Basic Assessments

Project Name & Location	Client Name	Role
Basic Assessment Process for Sirius 2x 100MW Solar Photovoltaic facilities, Upington, Northern Cape	SOLA Future Energy (Pty) Ltd Tseliso Mahao: 076 067 8221	EAP
Basic Assessment Process for Aggeneys 2x 100MW Solar Photovoltaic facilities and associated grid connection infrastructure, Aggeneys, Northern Cape.	Atlantic Energy Partners (Pty) Ltd and ABO Wind Aggeneys PV 1 and 2 (Pty) Ltd Sonia Miszczak: 021 418 2596	Junior EAP
Basic Assessment Process for Khunab 4x 75MW Solar Photovoltaic facilities near Upington, Northern Cape.	Atlantic Energy Partners (Pty) Ltd Peter Smith: 021 418 2596	EAP
Basic Assessment Process for the Naledi & Ngwedi 100MW Solar Photovoltaic facilities near Upington, Northern Cape.	Atlantic Energy Partners (Pty) Ltd Peter Smith: 021 418 2596	EAP
Basic Assessment Process for the Geelstert Solar Photovoltaic facilities and Grid Connection Solution near Aggeneys, Northern Cape.	Atlantic Energy Partners (Pty) Ltd Michael Johnson: 021 418 2596	EAP

Section 53 Applications

Project Name & Location	Client Name	Role
Section 53 applications for the Veld PV North and PV South, Northern Cape.	Veld Renewables (Pty) Ltd Jason Cope: 021 020 1044/ 082 598 1123	EAP

Part 1 Amendments

Project Name & Location	Client Name	Role
20MW Konkoonsies Solar Photovoltaic Facility, Pofadder, Northern Cape.	Biotherm Energy (Pty) Ltd Michael Barnes: 011 367 4600	Junior EAP
10MW Aries Solar PV Photovoltaic Facility, near Kenhardt, Northern Cape.	Biotherm Energy (Pty) Ltd Michael Barnes: 011 367 4600	Junior EAP
27MW Klipheuwel/Dassiefontein Wind Energy Facility near Calendon, Western Cape.	Biotherm Energy (Pty) Ltd Michael Barnes: 011 367 4600	Junior EAP
Matzikama Solar PV Photovoltaic Facility, near Vredendal, Western Cape.	SolaireDirect (Pty) Ltd Reggie Niemand: 082 674 1233	EAP
Grootspruit Solar PV Photovoltaic Facility, near Welkom, Free State.	SolaireDirect (Pty) Ltd	EAP

	Reggie Niemand: 082 674 1233	
Reddersburg Solar PV Photovoltaic Facility, near Reddersburg, Free State.	SolaireDirect (Pty) Ltd Reggie Niemand: 082 674 1233	EAP
Graspan Solar PV Photovoltaic Facility, near Hopetown, Northern Cape	SolaireDirect (Pty) Ltd Reggie Niemand: 082 674 1233	EAP

Infrastructure Development

Basic Assessments

Project Name & Location	Client Name	Role
Basic Assessment Process for the Wilmar Vegetable Oil Pipeline, Richards Bay, Kwa-Zulu Natal.	Wilmar Processing (Pty) Ltd Aidan Dowdle: 082 872 3628	Junior EAP
Basic Assessment Process for the Olifantshoek 132kV Power Line, Olifantshoek, Northern Cape	MVM Consulting Engineers (Pty) Ltd Pierre Van Rhyn: 012 348 2785	EAP

Waste Management

Basic Assessments

Project Name & Location	Client Name	Role
Decommissioning of the Asbestos landfill at the Kriel Power Station, Mpumalanga. .	Eskom Holdings SOC Limited Khuliso Rasimphi : 017 615 2634	EAP

Compliance Monitoring

Project Name & Location	Client Name	Role
Witsieshoek-Sorata 132kV Power Line, Free State Province	Eskom Holdings SOC Limited Mahlatse Moeng: 051 404 2287/079 199 0679	ECO
Genoegsaam Solar Photovoltaic Facilities S54 Audit, Eastern Cape Province	SolaireDirect (Pty) Ltd Reggie Niemand: 082 674 1233	Auditor
Valleydora Solar Photovoltaic Facility S54 Audit, Free State Province	SolaireDirect (Pty) Ltd Reggie Niemand: 082 674 1233	Auditor
Sannaspos Solar Photovoltaic Facility S54 Audit, Free State Province	SolaireDirect (Pty) Ltd Reggie Niemand: 082 674 1233	Auditor
Drennan Solar Photovoltaic Facility S54 Audit, Free State Province	SolaireDirect (Pty) Ltd Reggie Niemand: 082 674 1233	Auditor
Graspan Solar Photovoltaic Facility S54 Audit, Northern Cape Province	SolaireDirect (Pty) Ltd Reggie Niemand: 082 674 1233	Auditor
Grootspruit Solar Photovoltaic Facility S54 Audit, Free State Province	SolaireDirect (Pty) Ltd Reggie Niemand: 082 674 1233	Auditor

CURRICULUM VITAE OF JO-ANNE THOMAS

Profession:	Environmental Management and Compliance Consultant; Environmental Assessment Practitioner
Specialisation:	Environmental Management; Strategic environmental advice; Environmental compliance advice & monitoring; Environmental Impact Assessments; Policy, strategy & guideline formulation; Project Management; General Ecology
Work experience:	Twenty one (21) years in the environmental field

VOCATIONAL EXPERIENCE

Provide technical input for projects in the environmental management field, specialising in Strategic Environmental Advice, Environmental Impact Assessment studies, environmental auditing and monitoring, environmental permitting, public participation, Environmental Management Plans and Programmes, environmental policy, strategy and guideline formulation, and integrated environmental management. Key focus on integration of the specialist environmental studies and findings into larger engineering-based projects, strategic assessment, and providing practical and achievable environmental management solutions and mitigation measures. Responsibilities for environmental studies include project management (including client and authority liaison and management of specialist teams); review and manipulation of data; identification and assessment of potential negative environmental impacts and benefits; review of specialist studies; and the identification of mitigation measures. Compilation of the reports for environmental studies is in accordance with all relevant environmental legislation.

Undertaking of numerous environmental management studies has resulted in a good working knowledge of environmental legislation and policy requirements. Recent projects have been undertaken for both the public- and private-sector, including compliance advice and monitoring, electricity generation and transmission projects, various types of linear developments (such as National Road, local roads and power lines), waste management projects (landfills), mining rights and permits, policy, strategy and guideline development, as well as general environmental planning, development and management.

SKILLS BASE AND CORE COMPETENCIES

- Project management for a range of projects
- Identification and assessment of potential negative environmental impacts and benefits through the review and manipulation of data and specialist studies
- Identification of practical and achievable mitigation and management measures and the development of appropriate management plans
- Compilation of environmental reports in accordance with relevant environmental legislative requirements
- External and peer review of environmental reports & compliance advice and monitoring
- Formulation of environmental policies, strategies and guidelines
- Strategic and regional assessments; pre-feasibility & site selection
- Public participation processes for a variety of projects
- Strategic environmental advice to a wide variety of clients both in the public and private sectors
- Working knowledge of environmental planning processes, policies, regulatory frameworks and legislation

EDUCATION AND PROFESSIONAL STATUS

Degrees:

- B.Sc Earth Sciences, University of the Witwatersrand, Johannesburg (1993)
- B.Sc Honours in Botany, University of the Witwatersrand, Johannesburg (1994)
- M.Sc in Botany, University of the Witwatersrand, Johannesburg (1996)

Short Courses:

- Environmental Impact Assessment, Potchefstroom University (1998)
- Environmental Law, Morgan University (2001)
- Environmental Legislation, IMBEWU (2017)
- Mining Legislation, Cameron Cross & Associates (2013)
- Environmental and Social Risk Management (ESRM), International Finance Corporation (2018)

Professional Society Affiliations:

- Registered with the South African Council for Natural Scientific Professions as a Professional Natural Scientist: Environmental Scientist (400024/00)
- Registered with the International Association for Impact Assessment South Africa (IAIASa): 5601
- Member of the South African Wind Energy Association (SAWEA)

EMPLOYMENT

Date	Company	Roles and Responsibilities
January 2006 - Current	Savannah Environmental (Pty) Ltd	Director Project manager Independent specialist environmental consultant, Environmental Assessment Practitioner (EAP) and advisor.
1997 – 2005	Bohlweki Environmental (Pty) Ltd	Senior Environmental Scientist at. Environmental Management and Project Management
January – July 1997	Sutherland High School, Pretoria	Junior Science Teacher

PROJECT EXPERIENCE

Project experience includes large infrastructure projects, including electricity generation and transmission, wastewater treatment facilities, mining and prospecting activities, property development, and national roads, as well as strategy and guidelines development.

RENEWABLE POWER GENERATION PROJECTS: PHOTOVOLTAIC SOLAR ENERGY FACILITIES

Environmental Impact Assessments and Environmental Management Programmes

Project Name & Location	Client Name	Role
Christiana PV 2 SEF, North West	Solar Reserve South Africa	Project Manager & EAP
De Aar PV facility, Northern Cape	iNca Energy	Project Manager & EAP
Everest SEF near Hennenman, Free State	FRV Energy South Africa	Project Manager & EAP
Graafwater PV SEF, Western Cape	iNca Energy	Project Manager & EAP
Grootkop SEF near Allanridge, Free State	FRV Energy South Africa	Project Manager & EAP
Hertzogville PV 2 SEF with 2 phases, Free State	SunCorp / Solar Reserve	Project Manager & EAP
Karoshhoek CPV facility on site 2 as part of the larger Karoshhoek Solar Valley Development East of Upington, Northern Cape	FG Emvelo	Project Manager & EAP

Project Name & Location	Client Name	Role
Kgabalatsane SEF North-East for Brits, North West	Built Environment African Energy Services	Project Manager & EAP
Kleinbegin PV SEF West of Groblershoop, Northern Cape	MedEnergy Global	Project Manager & EAP
Lethabo Power Station PV Installation, Free State	Eskom Holdings SoC Limited	Project Manager & EAP
Majuba Power Station PV Installation, Mpumalanga	Eskom Holdings SoC Limited	Project Manager & EAP
Merapi PV SEF Phase 1 – 4 South-East of Excelsior, Free State	SolaireDirect Southern Africa	Project Manager & EAP
Sannaspos Solar Park, Free State	SolaireDirect Southern Africa	Project Manager & EAP
Ofir-Zx PV Plant near Keimoes, Northern Cape	S28 Degrees Energy	Project Manager & EAP
Oryx SEF near Virginia, Free State	FRV Energy South Africa	Project Manager & EAP
Project Blue SEF North of Kleinsee, Northern Cape	WWK Development	Project Manager & EAP
S-Kol PV Plant near Keimoes, Northern Cape	S28 Degrees Energy	Project Manager & EAP
Sonnenberg PV Plant near Keimoes, Northern Cape	S28 Degrees Energy	Project Manager & EAP
Tutuka Power Station PV Installation, Mpumalanga	Eskom Transmission	Project Manager & EAP
Two PV sites within the Northern Cape	MedEnergy Global	Project Manager & EAP
Two PV sites within the Western & Northern Cape	iNca Energy	Project Manager & EAP
Upington PV SEF, Northern Cape	MedEnergy Global	Project Manager & EAP
Vredendal PV facility, Western Cape	iNca Energy	Project Manager & EAP
Waterberg PV plant, Limpopo	Thupela Energy	Project Manager & EAP
Watershed Phase I & II SEF near Litchtenburg, North West	FRV Energy South Africa	Project Manager & EAP
Alldays PV & CPV SEF Phase 1, Limpopo	BioTherm Energy	Project Manager & EAP
Hyperion PV Solar Development 1, 2, 3, 4, 5 & 6	Building Energy	Project Manager & EAP

Basic Assessments

Project Name & Location	Client Name	Role
Aberdeen PV SEF, Eastern Cape	BioTherm Energy	Project Manager & EAP
Christiana PV 1 SEF on Hartebeestpan Farm, North-West	Solar Reserve South Africa	Project Manager & EAP
Heuningspruit PV1 & PV 2 facilities near Koppies, Free State	Sun Mechanics	Project Manager & EAP
Kakamas PV Facility, Northern Cape	iNca Energy	Project Manager & EAP
Kakamas II PV Facility, Northern Cape	iNca Energy	Project Manager & EAP
Machadodorp 1 PV SEF, Mpumalanga	Solar To Benefit Africa	Project Manager & EAP
PV site within the Northern Cape	iNca Energy	Project Manager & EAP
PV sites within 4 ACSA airports within South Africa, National	Airports Company South Africa (ACSA)	Project Manager & EAP
RustMo1 PV Plant near Buffelspoort, North West	Momentous Energy	Project Manager & EAP
RustMo2 PV Plant near Buffelspoort, North West	Momentous Energy	Project Manager & EAP
RustMo3 PV Plant near Buffelspoort, North West	Momentous Energy	Project Manager & EAP
RustMo4 PV Plant near Buffelspoort, North West	Momentous Energy	Project Manager & EAP
Sannaspos PV SEF Phase 2 near Bloemfontein, Free State	SolaireDirect Southern Africa	Project Manager & EAP
Solar Park Expansion within the Rooiwal Power Station, Gauteng	AFRKO Energy	Project Manager & EAP
Steynsrus SEF, Free State	SunCorp	Project Manager & EAP

Project Name & Location	Client Name	Role
Sirius Solar PV Project Three and Sirius Solar PV Project Four (BA in terms of REDZ regulations), Northern Cape	SOLA Future Energy	Project Manager & EAP

Screening Studies

Project Name & Location	Client Name	Role
Allemans Fontein SEF near Noupoot, Northern Cape	Fusion Energy	Project Manager & EAP
Amandel SEF near Thabazimbi, Limpopo	iNca Energy	Project Manager & EAP
Arola/Doornplaat SEF near Ventersdorp, North West	FRV & iNca Energy	Project Manager & EAP
Bloemfontein Airport PV Installation, Free State	The Power Company	Project Manager & EAP
Brakspruit SEF near Klerksorp, North West	FRV & iNca Energy	Project Manager & EAP
Carolus Poort SEF near Noupoot, Northern Cape	Fusion Energy	Project Manager & EAP
Damfontein SEF near Noupoot, Northern Cape	Fusion Energy	Project Manager & EAP
Everest SEF near Welkom, Free State	FRV & iNca Energy	Project Manager & EAP
Gillmer SEF near Noupoot, Northern Cape	Fusion Energy	Project Manager & EAP
Grootkop SEF near Allansridge, Free State	FRV & iNca Energy	Project Manager & EAP
Heuningspruit PV1 & PV 2 near Koppies, Free State	Cronimat	Project Manager & EAP
Kimberley Airport PV Installation, Northern Cape	The Power Company	Project Manager & EAP
Kolonnade Mall Rooftop PV Installation in Tshwane, Gauteng	Momentous Energy	Project Manager & EAP
Loskop SEF near Groblersdal, Limpopo	S&P Power Unit	Project Manager & EAP
Marble SEF near Marble Hall, Limpopo	S&P Power Unit	Project Manager & EAP
Morgenson PV1 SEF South-West of Windsorton, Northern Cape	Solar Reserve South Africa	Project Manager & EAP
OR Tambo Airport PV Installation, Gauteng	The Power Company	Project Manager & EAP
Oryx SEF near Virginia, Free State	FRV & iNca Energy	Project Manager & EAP
Rhino SEF near Vaalwater, Limpopo	S&P Power Unit	Project Manager & EAP
Rustmo2 PV Plant near Buffelspoort, North West	Momentous Energy	Project Manager & EAP
Spitskop SEF near Northam, Limpopo	FRV & iNca Energy	Project Manager & EAP
Steynsrus PV, Free State	Suncorp	Project Manager & EAP
Tabor SEF near Polokwane, Limpopo	FRV & iNca Energy	Project Manager & EAP
Upington Airport PV Installation, Northern Cape	The Power Company	Project Manager & EAP
Valeria SEF near Hartebeestpoort Dam, North West	Solar to Benefit Africa	Project Manager & EAP
Watershed SEF near Lichtenburg, North West	FRV & iNca Energy	Project Manager & EAP
Witkop SEF near Polokwane, Limpopo	FRV & iNca Energy	Project Manager & EAP
Woodmead Retail Park Rooftop PV Installation, Gauteng	Momentous Energy	Project Manager & EAP

Environmental Compliance, Auditing and ECO

Project Name & Location	Client Name	Role
ECO and bi-monthly auditing for the construction of the Adams Solar PV Project Two South of Hotazel, Northern Cape	Enel Green Power	Project Manager
ECO for the construction of the Kathu PV Facility, Northern Cape	REISA	Project Manager
ECO and bi-monthly auditing for the construction of the Pulida PV Facility, Free State	Enel Green Power	Project Manager
ECO for the construction of the RustMo1 SEF, North West	Momentous Energy	Project Manager
ECO for the construction of the Sishen SEF, Northern	Windfall 59 Properties	Project Manager

Project Name & Location	Client Name	Role
Cape		
ECO for the construction of the Upington Airport PV Facility, Northern Cape	Sublunary Trading	Project Manager
Quarterly compliance monitoring of compliance with all environmental licenses for the operation activities at the Kathu PV facility, Northern Cape	REISA	Project Manager
ECO for the construction of the Konkoonies II PV SEF and associated infrastructure, Northern Cape	BioTherm Energy	Project Manager
ECO for the construction of the Aggeneys PV SEF and associated infrastructure, Northern Cape	BioTherm Energy	Project Manager

Compliance Advice and ESAP Reporting

Project Name & Location	Client Name	Role
Aggeneys Solar Farm, Northern Cape	BioTherm Energy	Environmental Advisor
Airies II PV Facility SW of Kenhardt, Northern Cape	BioTherm Energy	Environmental Advisor
Kalahari SEF Phase II in Kathu, Northern Cape	Engie	Environmental Advisor
Kathu PV Facility, Northern Cape	Building Energy	Environmental Advisor
Kenhardt PV Facility, Northern Cape	BioTherm Energy	Environmental Advisor
Kleinbegin PV SEF West of Groblershoop, Northern Cape	MedEnergy	Environmental Advisor
Konkoonies II SEF near Pofadder, Northern Cape	BioTherm Energy	Environmental Advisor
Konkoonies Solar Farm, Northern Cape	BioTherm Energy	Environmental Advisor
Lephalale SEF, Limpopo	Exxaro	Environmental Advisor
Pixley ka Seme PV Park, South-East of De Aar, Northern Cape	African Clean Energy Developments (ACED)	Environmental Advisor
RustMo1 PV Plant near Buffelspoort, North West	Momentous Energy	Environmental Advisor
Scuitdrift 1 SEF & Scuitdrift 2 SEF, Limpopo	Building Energy	Environmental Advisor
Sirius PV Plants, Northern Cape	Aurora Power Solutions	Environmental Advisor
Upington Airport PV Power Project, Northern Cape	Sublunary Trading	Environmental Advisor
Upington SEF, Northern Cape	Abengoa Solar	Environmental Advisor
Ofir-ZX PV SEF near Keimoes, Northern Cape	Networx S28 Energy	Environmental Advisor
Steynsrus PV1 & PV2 SEF's, Northern Cape	Cronimet Power Solutions	Environmental Advisor
Heuningspruit PV SEF, Northern Cape	Cronimet Power Solutions	Environmental Advisor

Due Diligence Reporting

Project Name & Location	Client Name	Role
5 PV SEF projects in Lephalale, Limpopo	iNca Energy	Environmental Advisor
Prieska PV Plant, Northern Cape	SunEdison Energy India	Environmental Advisor
Sirius Phase One PV Facility near Upington, Northern Cape	Aurora Power Solutions	Environmental Advisor

Environmental Permitting, S53, Water Use Licence (WUL), Waste Management Licence (WML) & Other Applications

Project Name & Location	Client Name	Role
Biodiversity Permit & WULA for the Aggeneys SEF near Aggeneys, Northern Cape	BioTherm Energy	Project Manager & EAP
Biodiversity Permit for the Konkoonies II SEF near Pofadder, Northern Cape	BioTherm Energy	Project Manager & EAP
Biodiversity Permitting for the Lephalale SEF, Limpopo	Exxaro Resources	Project Manager & EAP

Project Name & Location	Client Name	Role
Environmental Permitting for the Kleinbegin PV SEF West of Groblershoop, Northern Cape	MedEnergy	Project Manager & EAP
Environmental Permitting for the Upington SEF, Northern Cape	Abengoa Solar	Project Manager & EAP
Environmental Permitting for the Kathu PV Facility, Northern Cape	Building Energy	Project Manager & EAP
Environmental Permitting for the Konkoonsies Solar Farm, Northern Cape	BioTherm Energy	Project Manager & EAP
Environmental Permitting for the Lephalale SEF, Limpopo	Exxaro Resources	Project Manager & EAP
Environmental Permitting for the Scuitdrift 1 SEF & Scuitdrift 2 SEF, Limpopo	Building Energy	Project Manager & EAP
Environmental Permitting for the Sirius PV Plant, Northern Cape	Aurora Power Solutions	Project Manager & EAP
Environmental Permitting for the Steynsrus PV1 & PV2 SEF's, Northern Cape	Cronimet Power Solutions	Project Manager & EAP
Environmental Permitting for the Heuningspruit PV SEF, Northern Cape	Cronimet Power Solutions	Project Manager & EAP
Permits for the Kleinbegin and UAP PV Plants, Northern Cape	MedEnergy Global	Project Manager & EAP
S53 Application for Arriesfontein Solar Park Phase 1 – 3 near Danielskuil, Northern Cape	Solar Reserve / SunCorp	Project Manager & EAP
S53 Application for Hertzogville PV1 & PV 2 SEFs, Free State	Solar Reserve / SunCorp	Project Manager & EAP
S53 Application for the Bloemfontein Airport PV Facility, Free State	Sublunary Trading	Project Manager & EAP
S53 Application for the Kimberley Airport PV Facility, Northern Cape	Sublunary Trading	Project Manager & EAP
S53 Application for the Project Blue SEF, Northern Cape	WWK Developments	Project Manager & EAP
S53 Application for the Upington Airport PV Facility, Free State	Sublunary Trading	Project Manager & EAP
WULA for the Kalahari SEF Phase II in Kathu, Northern Cape	Engie	Project Manager & EAP
Environmental Permitting for the Steynsrus PV1 & PV2 SEF's, Northern Cape	Cronimet Power Solutions	Project Manager & EAP
Environmental Permitting for the Heuningspruit PV SEF, Northern Cape	Cronimet Power Solutions	Project Manager & EAP

RENEWABLE POWER GENERATION PROJECTS: CONCENTRATED SOLAR FACILITIES (CSP)

Environmental Impact Assessments and Environmental Management Programmes

Project Name & Location	Client Name	Role
Ilanga CSP 2, 3, 4, 5, 7 & 9 Facilities near Upington, Northern Cape	Emvelo Holdings	Project Manager & EAP
Ilanga CSP near Upington, Northern Cape	Ilangethu Energy	Project Manager & EAP
Ilanga Tower 1 Facility near Upington, Northern Cape	Emvelo Holdings	Project Manager & EAP

Project Name & Location	Client Name	Role
Karoshhoek CPVPD 1-4 facilities on site 2 as part of the larger Karoshhoek Solar Valley Development East of Upington, Northern Cape	FG Emvelo	Project Manager & EAP
Karoshhoek CSP facilities on sites 1.4; 4 & 5 as part of the larger Karoshhoek Solar Valley Development East of Upington, Northern Cape	FG Emvelo	Project Manager & EAP
Karoshhoek Linear Fresnel 1 Facility on site 1.1 as part of the larger Karoshhoek Solar Valley Development East of Upington, Northern Cape	FG Emvelo	Project Manager & EAP

Environmental Compliance, Auditing and ECO

Project Name & Location	Client Name	Role
ECO for the construction of the !Khi CSP Facility, Northern Cape	Abengoa Solar	Project Manager
ECO for the construction of the Ilanga CSP 1 Facility near Upington, Northern Cape	Karoshhoek Solar One	Project Manager
ECO for the construction of the Solar Park, Northern Cape	Kathu Solar	Project Manager
ECO for the construction of the KaXu! CSP Facility, Northern Cape	Abengoa Solar	Project Manager
Internal audit of compliance with the conditions of the IWUL issued to the Karoshhoek Solar One CSP Facility, Northern Cape	Karoshhoek Solar One	Project Manager

Screening Studies

Project Name & Location	Client Name	Role
Upington CSP (Tower) Plant near Kanoneiland, Northern Cape	iNca Energy and FRV	Project Manager & EAP

Compliance Advice and ESAP reporting

Project Name & Location	Client Name	Role
Ilanga CSP Facility near Upington, Northern Cape	Ilangethu Energy	Environmental Advisor
Ilangaletu CSP 2, Northern Cape	FG Emvelo	Environmental Advisor
Kathu CSP Facility, Northern Cape	GDF Suez	Environmental Advisor
Lephalale SEF, Limpopo	Cennergi	Environmental Advisor
Solis I CSP Facility, Northern Cape	Brightsource	Environmental Advisor

Environmental Permitting, S53, Water Use Licence (WUL), Waste Management Licence (WML) & Other Applications

Project Name & Location	Client Name	Role
Environmental Permitting for the Ilanga CSP Facility near Upington, Northern Cape	Ilangethu Energy	Project Manager & EAP
Environmental Permitting for the Kathu CSP, Northern Cape	GDF Suez	Project Manager & EAP
WULA for the Solis I CSP Facility, Northern Cape	Brightsource	Project Manager & EAP

RENEWABLE POWER GENERATION PROJECTS: WIND ENERGY FACILITIES

Environmental Impact Assessments and Environmental Management Programmes

Project Name & Location	Client Name	Role
Sere WEF, Western Cape	Eskom Holdings SoC Limited	EAP

Project Name & Location	Client Name	Role
Aberdeen WEF, Eastern Cape	Eskom Holdings SoC Limited	Project Manager & EAP
Amakhala Emoyeni WEF, Eastern Cape	Windlab Developments	Project Manager & EAP
EXXARO West Coast WEF, Western Cape	EXXARO Resources	Project Manager & EAP
Goereesoe Wind Farm near Swellendam, Western Cape	iNca Energy	Project Manager & EAP
Hartneest WEF, Western Cape	Juwi Renewable Energies	Project Manager & EAP
Hopefield WEF, Western Cape	Umoya Energy	EAP
Kleinsee WEF, Northern Cape	Eskom Holdings SoC Limited	Project Manager & EAP
Klipheuwel/Dassiesfontein WEF within the Overberg area, Western Cape	BioTherm Energy	Project Manager & EAP
Moorreesburg WEF, Western Cape	iNca Energy	Project Manager & EAP
Oyster Bay WEF, Eastern Cape	Renewable Energy Resources Southern Africa	Project Manager & EAP
Project Blue WEF, Northern Cape	Windy World	Project Manager & EAP
Rheboksfontein WEF, Western Cape	Moyeng Energy	Project Manager & EAP
Spitskop East WEF near Riebeeck East, Eastern Cape	Renewable Energy Resources Southern Africa	Project Manager & EAP
Suurplaat WEF, Western Cape	Moyeng Energy	Project Manager & EAP
Swellendam WEF, Western Cape	IE Swellendam	Project Manager & EAP
Tsitsikamma WEF, Eastern Cape	Exxarro	Project Manager & EAP
West Coast One WEF, Western Cape	Moyeng Energy	Project Manager & EAP

Basic Assessments

Project Name & Location	Client Name	Role
Amakhala Emoyeni Wind Monitoring Masts, Eastern Cape	Windlab Developments	Project Manager & EAP
Beaufort West Wind Monitoring Masts, Western Cape	Umoya Energy	Project Manager & EAP
Hopefield Community Wind Farm near Hopefield, Western Cape	Umoya Energy	Project Manager & EAP
Koekenaap Wind Monitoring Masts, Western Cape	EXXARO Resources	Project Manager & EAP
Koingnaas WEF, Northern Cape	Just Palm Tree Power	Project Manager & EAP
Laingsburg Area Wind Monitoring Masts, Western Cape	Umoya Energy	Project Manager & EAP
Overberg Area Wind Monitoring Masts, Western Cape	BioTherm Energy	Project Manager & EAP
Oyster Bay Wind Monitoring Masts, Eastern Cape	Renewable Energy Systems Southern Africa (RES)	Project Manager & EAP

Screening Studies

Project Name & Location	Client Name	Role
Albertinia WEF, Western Cape	BioTherm Energy	Project Manager & EAP
Koingnaas WEF, Northern Cape	Just Pal Tree Power	Project Manager & EAP
Napier Region WEF Developments, Western Cape	BioTherm Energy	Project Manager & EAP
Tsitsikamma WEF, Eastern Cape	Exxarro Resources	Project Manager & EAP
Various WEFs within an identified area in the Overberg area, Western Cape	BioTherm Energy	Project Manager & EAP
Various WEFs within an identified area on the West Coast, Western Cape	Investec Bank Limited	Project Manager & EAP
Various WEFs within an identified area on the West Coast, Western Cape	Eskom Holdings Limited	Project Manager & EAP

Project Name & Location	Client Name	Role
Various WEFs within the Western Cape	Western Cape Department of Environmental Affairs and Development Planning	Project Manager & EAP
Velddrift WEF, Western Cape	VentuSA Energy	Project Manager & EAP
Wind 1000 Project	Thabo Consulting on behalf of Eskom Holdings	Project Manager & EAP
Wittekleibosch, Snylip & Doriskraal WEFs, Eastern Cape	Exxarro Resources	Project Manager & EAP

Environmental Compliance, Auditing and ECO

Project Name & Location	Client Name	Role
ECO for the construction of the West Coast One WEF, Western Cape	Aurora Wind Power	Project Manager
ECO for the construction of the Gouda WEF, Western Cape	Blue Falcon	Project Manager
EO for the Dassiesklip Wind Energy Facility, Western Cape	Group 5	Project Manager
Quarterly compliance monitoring of compliance with all environmental licenses for the operation activities at the Gouda Wind Energy facility near Gouda, Western Cape	Blue Falcon	Project Manager
Annual auditing of compliance with all environmental licenses for the operation activities at the West Coast One Wind Energy facility near Vredenburg, Western Cape	Aurora Wind Power	Project Manager
External environmental and social audit for the Amakhala Wind Farm, Eastern Cape	Cennergi	Project Manager
External environmental and social audit for the Tsitsikamma Wind Farm, Eastern Cape	Cennergi	Project Manager
ECO for the construction of the Excelsior Wind Farm and associated infrastructure, Northern Cape	BioTherm Energy	Project Manager
External compliance audit of the Dassiesklip Wind Energy Facility, Western Cape	BioTherm Energy	Project Manager

Compliance Advice

Project Name & Location	Client Name	Role
Amakhala Phase 1 WEF, Eastern Cape	Cennergi	Environmental Advisor
Dassiesfontein WEF within the Overberg area, Western Cape	BioTherm Energy	Environmental Advisor
Excelsior Wind Farm, Western Cape	BioTherm Energy	Environmental Advisor
Great Karoo Wind Farm, Northern Cape	African Clean Energy Developments (ACED)	Environmental Advisor
Hopefield Community WEF, Western Cape	African Clean Energy Developments (ACED)	Environmental Advisor
Rheboksfontein WEF, Western Cape	Moyeng Energy	Environmental Advisor
Tiqua WEF, Western Cape	Cennergi	Environmental Advisor
Tsitsikamma WEF, Eastern Cape	Cennergi	Environmental Advisor
West Coast One WEF, Western Cape	Moyeng Energy	Environmental Advisor

Due Diligence Reporting

Project Name & Location	Client Name	Role
Witteberg WEF, Western Cape	EDPR Renewables	Environmental Advisor
IPD Vredenburg WEF within the Saldanha Bay area, Western Cape	IL&FS Energy Development Company	Environmental Advisor

Environmental Permitting, S53, Water Use Licence (WUL), Waste Management Licence (WML) & Other Applications

Project Name & Location	Client Name	Role
Biodiversity Permitting for the Power Line between the Tsitikamma Community WEF & the Diep River Substation, Eastern Cape	Cennergi	Project Manager & EAP
Biodiversity Permitting for the West Coast One WEF, Western Cape	Aurora Wind Power	Project Manager & EAP
Environmental Permitting for the Excelsior WEF, Western Cape	BioTherm Energy	Project Manager & EAP
Plant Permits & WULA for the Tsitikamma Community WEF, Eastern Cape	Cennergi	Project Manager & EAP
S24G and WULA for the Rectification for the commencement of unlawful activities on Ruimsig AH in Honeydew, Gauteng	Hossam Soror	Project Manager & EAP
S24G Application for the Rhebokfontein WEF, Western Cape	Ormonde - Theo Basson	Project Manager & EAP
S53 Application & WULA for Suurplaat and Gemini WEFs, Northern Cape	Engie	Project Manager & EAP
S53 Application for the Hopefield Community Wind Farm near Hopefield, Western Cape	Umoya Energy	Project Manager & EAP
S53 Application for the Project Blue WEF, Northern Cape	WWK Developments	Project Manager & EAP
S53 for the Oyster Bay WEF, Eastern Cape	RES	Project Manager & EAP
WULA for the Great Karoo Wind Farm, Northern Cape	African Clean Energy Developments (ACED)	Project Manager & EAP

CONVENTIONAL POWER GENERATION PROJECTS (COAL)

Environmental Impact Assessments and Environmental Management Programmes

Project Name & Location	Client Name	Role
Mutsho Power Station near Makhado, Limpopo	Mutsho Consortium	Project Manager & EAP
Coal-fired Power Station near Ogies, Mpumalanga	Ruukki SA	Project Manager & EAP
Thabametsi IPP Coal-fired Power Station, near Lephallale, Limpopo	Axia	Project Manager & EAP
Transalloys Coal-fired Power Station, Mpumalanga	Transalloys	Project Manager & EAP
Tshivasho IPP Coal-fired Power Station (with WML), near Lephallale, Limpopo	Cennergi	Project Manager & EAP
Umbani Coal-fired Power Station, near Kriel, Mpumalanga	ISS Global Mining	Project Manager & EAP
Waterberg IPP Coal-Fired Power Station near Lephallale, Limpopo	Exxaro Resources	Project Manager & EAP

Basic Assessments

Project Name & Location	Client Name	Role
Coal Stockyard on Medupi Ash Dump Site, Limpopo	Eskom Holdings	Project Manager & EAP

Project Name & Location	Client Name	Role
Biomass Co-Firing Demonstration Facility at Arnot Power Station East of Middleburg, Mpumlanaga	Eskom Holdings	Project Manager & EAP

Screening Studies

Project Name & Location	Client Name	Role
Baseload Power Station near Lephallale, Limpopo	Cennergi	Project Manager & EAP
Coal-Fired Power Plant near Delmas, Mpumalanga	Exxaro Resources	Project Manager & EAP
Makhado Power Station, Limpopo	Mutsho Consortium, Limpopo	Project Manager & EAP

Environmental Compliance, Auditing and ECO

Project Name & Location	Client Name	Role
ECO for the Camden Power Station, Mpumalanga	Eskom Holdings	Project Manager

Compliance Advice

Project Name & Location	Client Name	Role
Thabametsi IPP Coal-fired Power Station, near Lephallale, Limpopo	Axia	Environmental Advisor

Environmental Permitting, S53, Water Use Licence (WUL), Waste Management Licence (WML) & Other Applications

Project Name & Location	Client Name	Role
Permit application for the Thabametsi Bulk Water Pipeline, near Lephallale, Limpopo	Axia	Project Manager & EAP
S53 & WULA for the Waterberg IPP Coal-Fired Power Station near Lephallale, Limpopo	Exxaro Resources	Project Manager & EAP
S53 Application for the Tshivasho Coal-fired Power Station near Lephallale, Limpopo	Cennergi	Project Manager & EAP

CONVENTIONAL POWER GENERATION PROJECTS (GAS)

Environmental Impact Assessments and Environmental Management Programmes

Project Name & Location	Client Name	Role
Ankerlig OCGT to CCGT Conversion project & 400 kV transmission power line between Ankerlig and the Omega Substation, Western Cape	Eskom Holdings SoC Limited	Project Manager & EAP
Gourikwa OCGT to CCGT Conversion project & 400 kV transmission power line between Gourikwa & Proteus Substation, Western Cape	Eskom Holdings SoC Limited	Project Manager & EAP
Richards Bay Gas to Power Combined Cycle Power Station, KwaZulu-Natal	Eskom Holdings SoC Limited	Project Manager & EAP
Richards Bay Gas to Power Plant, KwaZulu-Natal	Richards Bay Gas	Project Manager & EAP
Decommissioning & Recommissioning of 3 Gas Turbine Units at Acacia Power Station & 1 Gas Turbine Unit at Port Rex Power Station to the existing Ankerlig Power Station in Atlantis Industria, Western Cape	Eskom Holdings	Project Manager & EAP
Two 132kV Chickadee Lines to the new Zonnebloem Switching Station, Mpumalanga	Eskom Holdings	Project Manager & EAP

Screening Studies

Project Name & Location	Client Name	Role
Fatal Flaw Analysis for 3 area identified for the establishment of a 500MW CCGT Power Station	Globeleq Advisors Limited	Project Manager & EAP
Richards Bay Gas to Power Combined Cycle Power Station, KwaZulu-Natal	Eskom Holdings SoC Limited	Project Manager & EAP

GRID INFRASTRUCTURE PROJECTS

Environmental Impact Assessments and Environmental Management Programmes

Project Name & Location	Client Name	Role
Aggeneis-Oranjemond Transmission Line & Substation Upgrade, Northern Cape	Eskom Transmission	Project Manager & EAP
Ankerlig-Omega Transmission Power Lines, Western Cape	Eskom Transmission	Project Manager & EAP
Karoshhoek Grid Integration project as part of the Karoshhoek Solar Valley Development East of Upington, Northern Cape	FG Emvelo	Project Manager & EAP
Koeberg-Omega Transmission Power Lines,, Western Cape	Eskom Transmission	Project Manager & EAP
Koeberg-Stikland Transmission Power Lines, Western Cape	Eskom Transmission	Project Manager & EAP
Kyalami Strengthening Project, Gauteng	Eskom Transmission	Project Manager & EAP
Mokopane Integration Project, Limpopo	Eskom Transmission	Project Manager & EAP
Saldanha Bay Strengthening Project, Western Cape	Eskom Transmission	Project Manager & EAP
Steelpoort Integration Project, Limpopo	Eskom Transmission	Project Manager & EAP
Transmission Lines from the Koeberg-2 Nuclear Power Station site, Western Cape	Eskom Transmission	Project Manager & EAP
Tshwane Strengthening Project, Phase 1, Gauteng	Eskom Transmission	Project Manager & EAP

Basic Assessments

Project Name & Location	Client Name	Role
Dassenberg-Koeberg Power Line Deviation from the Koeberg to the Ankerlig Power Station, Western Cape	Eskom Holdings	Project Manager & EAP
Golden Valley II WEF Power Line & Substation near Cookhouse, Eastern Cape	BioTherm Energy	Project Manager & EAP
Golden Valley WEF Power Line near Cookhouse, Eastern Cape	BioTherm Energy	Project Manager & EAP
Karoshhoek Grid Integration project as part of the Karoshhoek Solar Valley Development East of Upington, Northern Cape	FG Emvelo	Project Manager & EAP
Konkoonsies II PV SEF Power Line to the Paulputs Substation near Pofadder, Northern Cape	BioTherm Energy	Project Manager & EAP
Perdekraal West WEF Powerline to the Eskom Kappa Substation, Western Cape	BioTherm Energy	Project Manager & EAP
Rheboksfontein WEF Powerline to the Aurora Substation, Western Cape	Moyeng Energy	Project Manager & EAP
Soetwater Switching Station near Sutherland, Northern Cape	African Clean Energy Developments (ACED)	Project Manager & EAP

Solis Power I Power Line & Switchyard Station near Upington, Northern Cape	Brightsource	Project Manager & EAP
Stormwater Canal System for the Ilanga CSP near Upington, Northern Cape	Karoshhoek Solar One	Project Manager & EAP
Tsitsikamma Community WEF Powerline to the Diep River Substation, Eastern Cape	Eskom Holdings	Project Manager & EAP

Environmental Compliance, Auditing and ECO

Project Name & Location	Client Name	Role
ECO for the construction of the Ferrum-Mookodi Transmission Line, Northern Cape and North West	Trans-Africa Projects on behalf of Eskom	Project Manager
EO for the construction of the Gamma-Kappa Section A Transmission Line, Western Cape	Trans-Africa Projects on behalf of Eskom	Project Manager
EO for the construction of the Gamma-Kappa Section B Transmission Line, Western Cape	Trans-Africa Projects on behalf of Eskom	Project Manager
EO for the construction of the Hydra IPP Integration project, Northern Cape	Trans-Africa Projects on behalf of Eskom	Project Manager
EO for the construction of the Kappa-Sterrekus Section C Transmission Line, Western Cape	Trans-Africa Projects on behalf of Eskom	Project Manager
EO for the construction of the Namaqualand Strengthening project in Port Nolloth, Western Cape	Trans-Africa Projects on behalf of Eskom	Project Manager
ECO for the construction of the Neptune Substation Soil Erosion Mitigation Project, Eastern Cape	Eskom	Project Manager
ECO for the construction of the Ilanga-Gordonia 132kV power line, Northern Cape	Karoshhoek Solar One	Project Manager

Environmental Permitting, S53, Water Use Licence (WUL), Waste Management Licence (WML) & Other Applications

Project Name & Location	Client Name	Role
Environmental Permitting and WULA for the Rockdale B Substation & Loop in Power Lines,	Eskom Holdings	Project Manager & EAP
Environmental Permitting and WULA for the Steelpoort Integration project, Limpopo	Eskom Holdings	Project Manager & EAP
Environmental Permitting for Solis CSP near Upington, Northern Cape	Brightsource	Project Manager & EAP

MINING SECTOR PROJECTS

Environmental Impact Assessments and Environmental Management Programmes

Project Name & Location	Client Name	Role
Elitheni Coal Mine near Indwe, Eastern Cape	Elitheni Coal	Project Manager & EAP
Groot Letaba River Development Project Borrow Pits	Iiso	Project Manager & EAP
Grootegeluk Coal Mine for coal transportation infrastructure between the mine and Medupi Power Station (EMPr amendment) , Limpopo	Eskom Holdings	Project Manager & EAP
Waterberg Coal Mine (EMPr amendment), Limpopo	Sesoko Resources	Project Manager & EAP
Aluminium Plant WML & AEL, Gauteng	GfE-MIR Alloys & Minerals	Project Manager & EAP

Basic Assessments

Project Name & Location	Client Name	Role
Rare Earth Separation Plant in Vredendal, Western Cape	Rareco	Project Manager & EAP

Decommissioning and Demolition of Kilns 5 & 6 at the Slurry Plant, Kwa-Zulu Natal	PPC	Project Manager & EAP
---	-----	-----------------------

Environmental Compliance, Auditing and ECO

Project Name & Location	Client Name	Role
ECO for the construction of the Duhva Mine Water Recovery Project, Mpumalanga	Eskom Holdings SoC Limited	Project Manager
External compliance audit of Palesa Coal Mine's Integrated Water Use License (IWUL), near KwaMhlanga, Mpumalanga	HCI Coal	Project Manager
External compliance audit of Palesa Coal Mine's Waste Management License (WML) and EMP, near KwaMhlanga, Mpumalanga	HCI Coal	Project Manager
External compliance audit of Mbali Coal Mine's Integrated Water Use License (IWUL), near Ogies, Mpumalanga	HCI Coal	Project Manager
Independent External Compliance Audit of Water Use License (WUL) for the Tronox Namakwa Sands (TNS) Mining Operations (Brand se Baai), Western Cape	Tronox Namakwa Sands	Project Manager
Independent External Compliance Audit of Water Use License (WUL) for the Tronox Namakwa Sands (TNS) Mineral Separation Plant (MSP), Western Cape	Tronox Namakwa Sands	Project Manager
Independent External Compliance Audit of Water Use License (WUL) for the Tronox Namakwa Sands (TNS) Smelter Operations (Saldanha), Western Cape	Tronox Namakwa Sands	Project Manager
Compliance Auditing of the Waste Management Licence for the PetroSA Landfill Site at the GTL Refinery, Western Cape	PetroSA	Project Manager

Environmental Permitting, S53, Water Use Licence (WUL), Waste Management Licence (WML) & Other Applications

Project Name & Location	Client Name	Role
Waste Licence Application for the Rare Earth Separation Plant in Vredendal, Western Cape	Rareco	Project Manager & EAP
WULA for the Expansion of the Landfill site at Exxaro's Namakwa Sands Mineral Separation Plant, Western Cape	Exxaro Resources	Project Manager & EAP
S24G & WML for an Aluminium Plant, Gauteng	GfE-MIR Alloys & Minerals	Project Manager & EAP

INFRASTRUCTURE DEVELOPMENT PROJECTS (BRIDGES, PIPELINES, ROADS, WATER RESOURCES, STORAGE, ETC)

Environmental Impact Assessments and Environmental Management Programmes

Project Name & Location	Client Name	Role
Bridge across the Ngotwane River, on the border of South Africa and Botswana	Eskom Holdings	Project Manager & EAP
Chemical Storage Tanks, Metallurgical Plant Upgrade & Backfill Plant upgrade at South Deep Gold Mine, near Westonaria, Gauteng	Goldfields	Project Manager & EAP
Expansion of the existing Welgedacht Water Care Works, Gauteng	ERWAT	Project Manager & EAP

Project Name & Location	Client Name	Role
Golden Valley WEF Access Road near Cookhouse, Eastern Cape	BioTherm Energy	Project Manager & EAP
Great Fish River Wind Farm Access Roads and Watercourse Crossings near Cookhouse, Eastern Cape	African Clean Energy Developments (ACED)	Project Manager & EAP
Ilanga CSP Facility Watercourse Crossings near Upington, Northern Cape	Karoshok Solar one	Project Manager & EAP
Modification of the existing Hartebeestfontein Water Care Works, Gauteng	ERWAT	Project Manager & EAP
N10 Road Realignment for the Ilanga CSP Facility, East of Upington, Northern Cape	SANRAL	Project Manager & EAP
Nxuba (Bedford) Wind Farm Watercourse Crossings near Cookhouse, Eastern Cape	African Clean Energy Developments (ACED)	Project Manager & EAP
Pollution Control Dams at the Medupi Power Station Ash Dump & Coal Stockyard, Limpopo	Eskom	Project Manager & EAP
Qoboshane borrow pits (EMPr only), Eastern Cape	Emalahleni Local Municipality	Project Manager & EAP
Tsitsikamma Community WEF Watercourse Crossings, Eastern Cape	Cennergi	Project Manager & EAP
Clayville Central Steam Plant, Gauteng	Bellmall Energy	Project Manager & EAP
Msenge Emoyeni Wind Farm Watercourse Crossings and Roads, Eastern Cape	Windlab	Project Manager & EAP

Basic Assessments

Project Name & Location	Client Name	Role
Harmony Gold WWTW at Doornkop Mine, Gauteng	Harmony Doornkop Plant	Project Manager & EAP
Ofir-ZX Watercourse Crossing for the Solar PV Facility, near Keimoes, Northern Cape	Networx S28 Energy	Project Manager & EAP
Qoboshane bridge & access roads, Eastern Cape	Emalahleni Local Municipality	Project Manager & EAP
Relocation of the Assay Laboratory near Carletonville, Gauteng	Sibanye Gold	Project Manager & EAP
Richards Bay Harbour Staging Area, KwaZulu-Natal	Eskom Holdings	Project Manager & EAP
S-Kol Watercourse Crossing for the Solar PV Facility, East of Keimoes, Northern Cape	Networx S28 Energy	Project Manager & EAP
Sonnenberg Watercourse Crossing for the Solar PV Facility, West Keimoes, Northern Cape	Networx S28 Energy	Project Manager & EAP
Kruisvallei Hydroelectric Power Generation Scheme, Free State	Building Energy	Project Manager & EAP
Masetjaba Water Reservoir, Pump Station and Bulk Supply Pipeline near Nigel, Gauteng	Naidu Consulting Engineers	Project Manager & EAP
Access Road for the Dwarsug Wind Farm, Northern Cape Province	South Africa Mainsteam Renewable Power	Project Manager & EAP
Upgrade of the Cooling Water Treatment Facility at the Kriel Power Station, Mpumalanga	Eskom	Project Manager & EAP

Screening Studies

Project Name & Location	Client Name	Role
Roodepoort Open Space Optimisation Programme (OSOP) Precinct, Gauteng	TIMAC Engineering Projects	Project Manager & EAP
Vegetable Oil Plant and Associated Pipeline, Kwa-Zulu Natal	Wilmar Oils and Fats Africa	Project Manager & EAP

Environmental Compliance, Auditing and ECO

Project Name & Location	Client Name	Role
ECO and bi-monthly auditing for the construction of the Olifants River Water Resources Development Project (ORWRDP) Phase 2A: De Hoop Dam, R555 realignment and housing infrastructure	Department of Water and Sanitation	Project Manager Auditor
ECO for the Rehabilitation of the Blaaupan & Storm Water Channel, Gauteng	Airports Company of South Africa (ACSA)	Project Manager
Due Diligence reporting for the Better Fuel Pyrolysis Facility, Gauteng	Better Fuels	Project Manager
ECO for the Construction of the Water Pipeline from Kendal Power Station to Kendal Pump Station, Mpumalanga	Transnet	Project Manager
ECO for the Replacement of Low-Level Bridge, Demolition and Removal of Artificial Pong, and Reinforcement the Banks of the Crocodile River at the Construction at Walter Sisulu National Botanical Gardens, Gauteng Province	South African National Biodiversity Institute (SANBI)	Project Manager
External Compliance Audit of the Air Emission Licence (AEL) for a depot in Bloemfontein, Free State Province and in Tzaneen, Mpumalanga Province	PetroSA	Project Manager

Environmental Permitting, S53, Water Use Licence (WUL), Waste Management Licence (WML) & Other Applications

Project Name & Location	Client Name	Role
WULA for the Izubulo Private Nature Reserve, Limpopo	Kjell Bismeyer, Jann Bader, Laurence Saad	Project Manager & EAP
WULA for the Masodini Private Game Lode, Limpopo	Masodini Private Game Lodge	Environmental Advisor
WULA for the Ezulwini Private Nature Reserve, Limpopo	Ezulwini Investments	Project Manager & EAP
WULA for the Masodini Private Game Lode, Limpopo	Masodini Private Game Lodge	Project Manager & EAP
WULA for the N10 Realignment at the Ilanga SEF, Northern Cape	Karoshhoek Solar One	Project Manager & EAP
WULA for the Kruisvallei Hydroelectric Power Generation Scheme, Free State	Building Energy	Project Manager & EAP
S24G and WULA for the illegal construction of structures within a watercourse on EFF 24 Ruimsig Agricultural Holdings, Gauteng	Sorrow Language Services	Project Manager & EAP

HOUSING AND URBAN PROJECTS

Basic Assessments

Project Name & Location	Client Name	Role
Postmasburg Housing Development, Northern Cape	Transnet	Project Manager & EAP

Compliance Advice and reporting

Project Name & Location	Client Name	Role
Kampi ya Thude at the Olifants West Game Reserve, Limpopo	Nick Elliot	Environmental Advisor

Project Name & Location	Client Name	Role
External Compliance Audit of WUL for the Johannesburg Country Club, Gauteng	Johannesburg Country Club	Project Manager

Environmental Compliance, Auditing and ECO

Project Name & Location	Client Name	Role
Due Diligence Audit for the Due Diligence Audit Report, Gauteng	Delta BEC (on behalf of Johannesburg Development Agency (JDA))	Project Manager

ENVIRONMENTAL MANAGEMENT TOOLS

Project Name & Location	Client Name	Role
Development of the 3rd Edition Environmental Implementation Plan (EIP)	Gauteng Department of Agriculture and Rural Development (GDARD)	Project Manager & EAP
Development of Provincial Guidelines on 4x4 routes, Western Cape	Western Cape Department of Environmental Affairs and Development Planning	EAP
Compilation of Construction and Operation EMP for the Braamhoek Transmission Integration Project, Kwazulu-Natal	Eskom Holdings	Project Manager & EAP
Compilation of EMP for the Wholesale Trade of Petroleum Products, Gauteng	Munaca Technologies	Project Manager & EAP
Operational Environmental Management Programme (OEMP) for Medupi Power Station, Limpopo	Eskom Holdings	Project Manager & EAP
Operational Environmental Management Programme (OEMP) for the Dube TradePort Site Wide Precinct	Dube TradePort Corporation	Project Manager & EAP
Operational Environmental Management Programme (OEMP) for the Kusile Power Station, Mpumalanga	Eskom Holdings	Project Manager & EAP
Review of Basic Assessment Process for the Wittekleibosch Wind Monitoring Mast, Eastern Cape	Exxaro Resources	Project Manager & EAP
Revision of the EMPr for the Sirius Solar PV	Aurora Power Solutions	Project Manager & EAP
State of the Environment (SoE) for Emalahleni Local Municipality, Mpumalanga	Simo Consulting on behalf of Emalahleni Local Municipality	Project Manager & EAP
Aspects and Impacts Register for Salberg Concrete Products operations	Salberg Concrete Products	EAP
First State of Waste Report for South Africa	Golder on behalf of the Department of Environmental Affairs	Project Manager & EAP
Responsibilities Matrix and Gap Analysis for the Kruisvallei Hydroelectric Power Generation Scheme, Free State Province	Building Energy	Project Manager
Responsibilities Matrix and Gap Analysis for the Roggeveld Wind Farm, Northern & Western Cape Provinces	Building Energy	Project Manager

PROJECTS OUTSIDE OF SOUTH AFRICA

Project Name & Location	Client Name	Role
Advisory Services for the Zizabona Transmission Project, Zambia, Zimbabwe, Botswana & Namibia	PHD Capital	Advisor
EIA for the Semonkong WEF, Lesotho	MOSCET	Project Manager & EAP
EMP for the Kuvaninga Energia Gas Fired Power Project, Mozambique	ADC (Pty) Ltd	Project Manager & EAP
Environmental Screening Report for the SEF near Thabana Morena, Lesotho	Building Energy	EAP
EPBs for the Kawambwa, Mansa, Mwense and Nchelenge SEFs in Luapula Province, Zambia	Building Energy	Project Manager & EAP
ESG Due Diligence for the Hilton Garden Inn Development in Windhoek, Namibia	Vatange Capital	Project Manager
Mandahill Mall Rooftop PV SEF EPB, Lusaka, Zambia	Building Energy	Project Manager & EAP
Monthly ECO for the PV Power Plant for the Mocuba Power Station	Scatec	Project Manager

CURRICULUM VITAE OF LISA OPPERMAN

Profession :	Environmental Assessment Practitioner and GIS Consultant
Specialisation:	Environmental Impact Assessments, Basic Assessments, Site Screening and Site Selection reporting, compilation of maps through the use of ArcGIS
Work Experience:	4 years of experience in the environmental management and GIS field

VOCATIONAL EXPERIENCE

Lisa Opperman has four years of experience in the environmental field. She has worked on a variety of EIA processes including renewable energy projects, as well as industrial developments. She has also been involved in the undertaking of public participation for projects located in South Africa which has included the undertaking of public meetings, focus group meetings and key stakeholder meetings in both Afrikaans and English. She also has experience in working with ArcGIS 10 for the compilation of maps, the manipulation of data and screening for environmental sensitivities within areas with the potential for development.

SKILLS BASE AND CORE COMPETENCIES

- GIS Mapping
- EIA Report Writing
- Conducting of public involvement processes
- Administrative tasks
- Analysis and manipulation of geographical information and technical experience with the use of ArcGIS

EDUCATION AND PROFESSIONAL STATUS

Degrees:

- B.Sc. (Hons) Environmental Management (2014), North-West University, Potchefstroom
- B.A Psychology, Geography and Environmental Studies (2013), North-West University, Potchefstroom

Courses:

- Environmental Legal Compliance and Auditing (2017), Janice Tooley at the Protea Hotel OR Tambo, Johannesburg

EMPLOYMENT

Date	Company	Roles and Responsibilities
February 2015 – current	Savannah Environmental (Pty) Ltd	Environmental Assessment Practitioner and GIS Consultant <i>Tasks include: Compilation of Environmental Scoping Reports, Plan of Study, Environmental Impact Assessment Reports, Basic Assessments and Environmental management programmes; Environmental Screening Reports; Specialist management; project proposals and tenders; Client liaison and Marketing; Process EIA Applications, GIS Mapping and data analysis and manipulation</i>

PROJECT EXPERIENCE**Renewable Power Generation Projects: Solar Energy Facilities****Screening Studies**

Project Name & Location	Client Name	Role
<i>Pre-feasibility Desktop Screening and Fatal Flaw Scan for a Solar PV Project near Lichtenburg, North West Province</i>	ABO Wind AG	<i>EAP and GIS Consultant</i>
<i>Pre-feasibility Desktop Screening and Fatal Flaw Scan for a Solar PV Project neat Aggeneys, Northern Cape Province</i>	ABO Wind AG	<i>EAP and GIS Consultant</i>

Environmental Impact Assessments and Environmental Management Programmes

Project Name & Location	Client Name	Role
<i>Buffels PV 1 & Buffels PV 2 Solar Energy Facilities near Orkney, North West</i>	<i>Kabi Solar</i>	<i>EAP and GIS Consultant</i>
<i>Woodhouse Solar 1 & Woodhouse Solar 2 PV Facilities near Vryburg, North West</i>	<i>Genesis Eco-Energy Developments</i>	<i>EAP and GIS Consultant</i>
<i>Orkney Solar Farm, North West</i>	<i>Genesis Eco-Energy Developments</i>	<i>EAP and GIS Consultant</i>
<i>Tewa Isitha Solar 1 & Tewa Isitha Solar 2 PV facilities near Upington, Northern Cape</i>	<i>AfriCoast Energy</i>	<i>EAP and GIS Consultant</i>
<i>Lichtenburg 1, Lichtenburg 2 and Lichtenburg 3 PV Facilities, near Lichtenburg, North West Province (EIA Phase)</i>	ABO Wind AG	<i>EAP and GIS Consultant</i>

Basic Assessments

Project Name & Location	Client Name	Role
<i>Harmony Gold 3x PV Facilities, Welkom, Free State</i>	BBEntropie	<i>EAP and GIS Consultant</i>

Renewable power generation projects: Wind Energy Facilities

Screening Studies

Project Name & Location	Client Name	Role
<i>Juno Wind Farm Screening Assessment Report near Lamberts Bay, Western Cape Province</i>	<i>AMDA Developments</i>	<i>EAP and GIS Consultant</i>
<i>Lamberts Bay Wind Farm Screening Assessment Report near Lamberts Bay, Western Cape Province</i>	<i>Windy World</i>	<i>EAP and GIS Consultant</i>
<i>Pre-feasibility Desktop Screening and Fatal Flaw Scan for the Kudusberg and Rondekop Wind Energy Facilities, Northern Cape and Western Cape Provinces</i>	<i>ABO Wind AG</i>	<i>EAP and GIS Consultant</i>
<i>Pre-feasibility Desktop Screening and Fatal Flaw Scan for Wind Projects near Touws River, Western Cape Province</i>	<i>ABO Wind AG</i>	<i>EAP and GIS Consultant</i>

Environmental Impact Assessments and Environmental Management Programmes

Project Name & Location	Client Name	Role
<i>Boulders Wind Farm, Western Cape Province</i>	<i>Vredenburg Windfarm</i>	<i>EAP and GIS Consultant</i>
<i>Namas Wind Farm, Northern Cape Province</i>	<i>Genesis Namas Wind (Pty) Ltd</i>	<i>EAP and GIS Consultant</i>
<i>Zonnequa Wind Farm, Northern Cape Province</i>	<i>Genesis Zonnequa Wind (Pty) Ltd</i>	<i>EAP and GIS Consultant</i>

Grid Infrastructure Projects

Basic Assessments

Project Name & Location	Client Name	Role
<i>132/11kV Olifantshoek Substation and Power Line, Northern Cape</i>	<i>Eskom</i>	<i>EAP and GIS Consultant</i>
<i>Grid connection infrastructure for the Namas Wind Farm, Northern Cape Province</i>	<i>Genesis Namas Wind (Pty) Ltd</i>	<i>EAP and GIS Consultant</i>
<i>Grid connection infrastructure for the Zonnequa Wind Farm, Northern Cape Province</i>	<i>Genesis Zonnequa Wind (Pty) Ltd</i>	<i>EAP and GIS Consultant</i>

Gas Projects

Environmental Impact Assessments and Environmental Management Programmes

Project Name & Location	Client Name	Role
<i>Richards Bay Combined Cycle Power Plant (CCPP) power plant, KwaZulu-Natal (Scoping Phase)</i>	<i>Eskom</i>	<i>EAP (assistance) and GIS Consultant</i>

Basic Assessments

Project Name & Location	Client Name	Role
<i>Neopak Combined Heat and Power (CHP) Plant, Rosslyn, Gauteng</i>	<i>Neopak</i>	<i>EAP, Public Participation and GIS Consultant</i>

Screening Studies

Project Name & Location	Client Name	Role
<i>Richards Bay Combined Cycle Power Plant (CCPP) power plant, near Richards Bay, KwaZulu-Natal</i>	<i>Eskom</i>	<i>EAP and GIS Consultant</i>

Infrastructure Development Projects (bridges, pipelines, roads, etc)

Basic Assessments

Project Name & Location	Client Name	Role
Water Treatment Plant at the Neopak Facility, Rosslyn, Gauteng	Neopak	EAP, Public Participation and GIS Consultant

Housing and Urban Projects

Environmental Impact Assessments and Environmental Management Programmes

Project Name & Location	Client Name	Role
Metals Industrial Cluster near Kuruman, Northern Cape	Northern Cape Department of Economic Development and Tourism	EAP and GIS Consultant

Environmental Management Tools

Environmental Management Programmes

Project Name & Location	Client Name	Role
Environmental Management Programme (EMPr) for the Nxuba Wind Farm, Eastern Cape	ACED	EAP
Operation Environmental Management Programme (EMPr) for Phase 1 of the Amakhala Emoyeni Wind Energy Facility, Eastern Cape	Cennergi	EAP
Operation Environmental Management Programme (EMPr) for the Tsitsikamma Community Wind Energy Facility, Eastern Cape Province	Cennergi	EAP
Environmental Management Programme (EMPr) for the Skuitdrift 1 Solar PV Energy Facility near Augrabies, Northern Cape Province	Building Energy South Africa	EAP and GIS Consultant
Environmental Management Programme (EMPr) for the Skuitdrift 2 Solar PV Energy Facility near Augrabies, Northern Cape Province	Building Energy South Africa	EAP and GIS Consultant

Environmental and Social Management System (ESMS)

Project Name & Location	Client Name	Role
Preparation of Policies and Plans for the Roggeveld Wind Farm, Western Cape Province	Building Energy South Africa	EAP assistance
Preparation of Policies and Plans for the Kruisvallei Hydro Scheme, Free State Province	Building Energy South Africa	EAP assistance

**Appendix K:
Key Legislation**

APPLICABLE LEGISLATION

Table 1: Applicable Legislation, Policies and/or Guidelines associated with the development of Lichtenburg 2

Legislation	Applicable Requirements	Relevant Authority	Compliance Requirements
National Legislation			
Constitution of the Republic of South Africa (No. 108 of 1996)	<p>In terms of Section 24, the State has an obligation to give effect to the environmental right. The environmental right states that:</p> <p><i>"Everyone has the right –</i></p> <ul style="list-style-type: none"> » <i>To an environment that is not harmful to their health or well-being; and</i> » <i>To have the environment protected, for the benefit of present and future generations, through reasonable legislative and other measures that:</i> <ul style="list-style-type: none"> * <i>Prevent pollution and ecological degradation;</i> * <i>Promote conservation; and</i> * <i>Secure ecologically sustainable development and use of natural resources while promoting justifiable economic and social development."</i> 	Applicable to all authorities	There are no permitting requirements associated with this Act. The application of the Environmental Right however implies that environmental impacts associated with proposed developments are considered separately and cumulatively. It is also important to note that the "right to an environment clause" includes the notion that justifiable economic and social development should be promoted, through the use of natural resources and ecologically sustainable development.
National Environmental Management Act (No 107 of 1998) (NEMA)	<p>The 2014 EIA Regulations have been promulgated in terms of Chapter 5 of NEMA. Listed activities which may not commence without EA are identified within the Listing Notices (GNR 327, GNR 325 and GNR 324) which form part of these Regulations (GNR 326).</p> <p>In terms of Section 24(1) of NEMA, the potential impact on the environment associated with these listed activities must be assessed and reported on to the competent authority charged by NEMA with granting of the relevant environmental authorisation.</p>	<p>DEA – Competent Authority</p> <p>North West READ – Commenting Authority</p>	The listed activities triggered by the proposed project have been identified and are being assessed as part of the EIA process currently underway for the project. The Scoping and EIA process will culminate in the submission of a Final EIA Report to the competent and commenting authority in support of the application for EA.

Legislation	Applicable Requirements	Relevant Authority	Compliance Requirements
	<p>In terms of the Listing Notices (GNR 327, GNR 325 and GNR 324), a full Scoping and EIA Process is required to be undertaken for the proposed project.</p>		
<p>National Environmental Management Act (No 107 of 1998) (NEMA)</p>	<p>In terms of the "Duty of Care and Remediation of Environmental Damage" provision in Section 28(1) of NEMA every person who causes, has caused or may cause significant pollution or degradation of the environment must take reasonable measures to prevent such pollution or degradation from occurring, continuing or recurring, or, in so far as such harm to the environment is authorised by law or cannot reasonably be avoided or stopped, to minimise and rectify such pollution or degradation of the environment.</p> <p>In terms of NEMA, it is the legal duty of a project proponent to consider a project holistically, and to consider the cumulative effect of a variety of impacts.</p>	<p>DEA North West READ</p>	<p>While no permitting or licensing requirements arise directly by virtue of the proposed project, this section finds application during the EIA Phase through the consideration of potential cumulative, direct, and indirect impacts. It will continue to apply throughout the life cycle of the project.</p>
<p>Environment Conservation Act (No. 73 of 1989) (ECA)</p>	<p>The Noise Control Regulations in terms of Section 25 of the ECA contain regulations applicable for the control of noise in the Provinces of Limpopo, North West, Mpumalanga, Northern Cape, Eastern Cape, and KwaZulu-Natal Provinces.</p> <p>The Noise Control Regulations cover the powers of a local authority, general prohibitions, prohibitions of disturbing noise, prohibitions of noise nuisance, use of measuring instruments, exemptions, attachments, and penalties.</p> <p>In terms of the Noise Control Regulations, no person shall make, produce or cause a disturbing noise, or allow it to be made, produced or caused by any person, machine,</p>	<p>DEA North West READ Ditsobotla LM</p>	<p>Noise impacts are expected to be associated with the construction phase of the project. Provided that appropriate mitigation measures are implemented, construction noise is likely to present a significant intrusion to the local community. There is therefore no requirement for a noise permit in terms of the legislation.</p>

Legislation	Applicable Requirements	Relevant Authority	Compliance Requirements
	device or apparatus or any combination thereof (Regulation 04).		
National Water Act (No. 36 of 1998) (NWA)	<p>A water use listed under Section 21 of the NWA must be licensed with the Regional DWS, unless it is listed in Schedule 1 of the NWA (i.e. is an existing lawful use), is permissible under a GA, or if a responsible authority waives the need for a licence.</p> <p>Water use is defined broadly, and includes consumptive and non-consumptive water uses. taking and storing water, activities which reduce stream flow, waste discharges and disposals, controlled activities (activities which impact detrimentally on a water resource), altering a watercourse, removing water found underground for certain purposes, and recreation.</p> <p>Consumptive water uses may include taking water from a water resource (Section 21(a)), and storing water (Section 21(b)).</p> <p>Non-consumptive water uses may include impeding or diverting of flow in a water course (Section 21(c)); and altering of bed, banks or characteristics of a watercourse (Section 21(i)).</p>	Regional DWS	In the event that water required for the project is sourced from a borehole drilled on site Section 21(a) of the NWA would be triggered, and the project proponent would need to apply for or WUL or register a GA with the DWS.
Minerals and Petroleum Resources Development Act (No. 28 of 2002) (MPRDA)	In accordance with the provisions of the MPRDA a mining permit is required in accordance with Section 27(6) of the Act where a mineral in question is to be mined, including the mining of materials from a borrow pit.	DMR	Any person who wishes to apply for a mining permit in accordance with Section 27(6) must simultaneously apply for an Environmental Authorisation. No borrow pits are expected to be required for the construction of the project, and as a result a mining permit is not required to be obtained.

Legislation	Applicable Requirements	Relevant Authority	Compliance Requirements
	<p>Section 53 of the MPRDA states that any person who intends to use the surface of any land in any way which may be contrary to any object of the Act, or which is likely to impede any such object must apply to the Minister for approval in the prescribed manner.</p>		<p>In terms of Section 53 of the MPRDA approval is required from the Minister of Mineral Resources to ensure that the proposed development does not sterilise a mineral resource that might occur on site.</p>
<p>National Environmental Management: Air Quality Act (No. 39 of 2004) (NEM:AQA)</p>	<p>The National Dust Control Regulations (GNR 827) published under Section 32 of NEM:AQA prescribe the general measures for the control of dust in all areas; and provide a standard for acceptable dustfall rates for residential and non-residential areas.</p> <p>In accordance with the Regulations (GNR 827) any person who conducts any activity in such a way as to give rise to dust in quantities and concentrations that may exceed the dustfall standard set out in Regulation 03 must, upon receipt of a notice from the air quality officer, implement a dustfall monitoring programme.</p> <p>Any person who has exceeded the dustfall standard set out in Regulation 03 must, within three months after submission of the dustfall monitoring report, develop and submit a dust management plan to the air quality officer for approval.</p>	<p>North West READ / Ngaka Modiri Molema DM</p>	<p>In the event that the project results in the generation of excessive levels of dust the possibility could exist that a dustfall monitoring programme would be required for the project, in which case dustfall monitoring results from the dustfall monitoring programme would need to be included in a dust monitoring report, and a dust management plan would need to be developed. However granted that appropriate mitigation measures are implemented, the proposed project is not anticipated to result in significant dust generation.</p>
<p>National Heritage Resources Act (No. 25 of 1999) (NHRA)</p>	<p>Section 07 of the NHRA stipulates assessment criteria and categories of heritage resources according to their significance.</p> <p>Section 35 of the NHRA provides for the protection of all archaeological and palaeontological sites, and meteorites.</p>	<p>SAHRA North West Provincial Heritage Resources Authority</p>	<p>A full HIA (with field work) has been undertaken as part of the EIA Phase (refer to Appendix G of the EIA Report). The HIA determined that no archaeological resources, graves or burial grounds were identified in the project area. However, graves are subterranean in nature and might not have been identified during the initial site visit and survey. Based on the nature of the project,</p>

Legislation	Applicable Requirements	Relevant Authority	Compliance Requirements
	<p>Section 36 of the NHRA provides for the conservation and care of cemeteries and graves by SAHRA where this is not the responsibility of any other authority.</p> <p>Section 38 of the NHRA lists activities which require developers or any person who intends to undertake a listed activity to notify the responsible heritage resources authority and furnish it with details regarding the location, nature, and extent of the proposed development.</p> <p>Section 44 of the NHRA requires the compilation of a Conservation Management Plan as well as a permit from SAHRA for the presentation of archaeological sites as part of tourism attraction.</p>		<p>surface activities may impact upon the fossil heritage if preserved in the development footprint. The geological structures suggest that rocks are too old to contain fossils other than blue-green algae. Taking account of the defined criteria, the potential to impact fossil heritage resources is negligible to extremely low. It also recommends appropriate mitigation measures for implementation to avoid, minimise, or mitigate impacts to heritage resources.</p> <p>Should a heritage resource of significance be impacted upon, a permit may be required from SAHRA or the North West Provincial Heritage Resources Authority in accordance with of Section 48 of the NHRA, and the SAHRA Permit Regulations (GNR 668). This will be determined once the final location of the project and its associated infrastructure within the project site has been determined.</p>
<p>National Environmental Management: Biodiversity Act (No. 10 of 2004) (NEM:BA)</p>	<p>Section 53 of NEM:BA provides for the MEC / Minister to identify any process or activity in such a listed ecosystem as a threatening process.</p> <p>Three government notices have been published in terms of Section 56(1) of NEM:BA as follows:</p> <ul style="list-style-type: none"> » Commencement of TOPS Regulations, 2007 (GNR 150). » Lists of critically endangered, vulnerable and protected species (GNR 151). » TOPS Regulations (GNR 152). 	<p>DEA North West READ</p>	<p>Under NEM:BA; a permit would be required for any activity which is of a nature that may negatively impact on the survival of a listed protected species. The Ecological Impact Assessment (Appendix D of the EIA Report) undertaken identified TOPS species which may be present within the project site. The species include species listed as protected, namely the South African Hedgehog, Spotted Hyena, Brown Hyena, Serval, Black-footed cat, Leopard, Honey Badger, Cape Fox, Cape</p>

Legislation	Applicable Requirements	Relevant Authority	Compliance Requirements
	<p>It provides for listing threatened or protected ecosystems, in one of four categories: critically endangered (CR), endangered (EN), and vulnerable (VU) or protected. The first national list of threatened terrestrial ecosystems has been gazetted, together with supporting information on the listing process including the purpose and rationale for listing ecosystems, the criteria used to identify listed ecosystems, the implications of listing ecosystems, and summary statistics and national maps of listed ecosystems (NEM:BA: National list of ecosystems that are threatened and in need of protection, (Government Gazette 37596, GNR 324), 29 April 2014).</p>		<p>Clawless Otter, Spotted-necked Otter, Black Wildebeest and Southern Reedbuck. Only one species listed as Vulnerable as part of TOPS was identified, known as the Ground Pangolin.</p>
<p>National Environmental Management: Biodiversity Act (No. 10 of 2004) (NEM:BA)</p>	<p>Chapter 5 of NEM:BA pertains to alien and invasive species; and states that a person may not carry out a restricted activity involving a specimen of an alien species without a permit issued in terms of Chapter 7 of NEM:BA; and that a permit may only be issued after a prescribed assessment of risks and potential impacts on biodiversity is carried out.</p> <p>Applicable, and exempted alien and invasive species are contained within the Alien and Invasive Species List (GNR 864).</p>	<p>DEA North West READ</p>	<p>Restricted Activities and the respective requirements applicable to persons in control of different categories of listed invasive species are contained within the Alien and Invasive Species Regulations (GNR 598) published under NEM:BA; together with the requirements of the Risk Assessment to be undertaken.</p>
<p>Conservation of Agricultural Resources Act (No. 43 of 1983) (CARA)</p>	<p>Section 05 of CARA provides for the prohibition of the spreading of weeds.</p> <p>Regulation 15 of GNR 1048 published under CARA provides for the classification of categories of weeds and invader plants, and restrictions in terms of where these species may occur.</p>	<p>DAFF</p>	<p>CARA will find application throughout the life cycle of the project. In this regard, soil erosion prevention and soil conservation strategies need to be developed and implemented. In addition, a weed control and management plan must be implemented.</p> <p>The permission of DAFF will be required if the Project requires the draining of vleis, marshes</p>

Legislation	Applicable Requirements	Relevant Authority	Compliance Requirements
	<p>Regulation 15E of GNR 1048 published under CARA provides requirement and methods to implement control measures for different categories of alien and invasive plant species.</p>		<p>or water sponges on land outside urban areas. However this is not anticipated to be required for the project.</p> <p>In terms of Regulation 15E (GNR 1048) where Category 1, 2, or 3 plants occur a land user is required to control such plants by means of one or more of the following methods:</p> <ul style="list-style-type: none"> » Uprooting, felling, cutting or burning. » Treatment with a weed killer that is registered for use in connection with such plants in accordance with the directions for the use of such a weed killer. » Biological control carried out in accordance with the stipulations of the Agricultural Pests Act (No. 36 of 1983), the ECA and any other applicable legislation. » Any other method of treatment recognised by the executive officer that has as its object the control of plants concerned, subject to the provisions of sub-regulation (4). » A combination of one or more of the methods prescribed, save that biological control reserves and areas where biological control agents are effective shall not be disturbed by other control methods to the extent that the agents are destroyed or become ineffective.

Legislation	Applicable Requirements	Relevant Authority	Compliance Requirements
National Forests Act (No. 84 of 1998) (NFA)	<p>According to this Act, the Minister may declare a tree, group of trees, woodland or a species of trees as protected.</p> <p>The prohibitions provide that “no person may cut, damage, disturb, destroy or remove any protected tree, or collect, remove, transport, export, purchase, sell, donate or in any other manner acquire or dispose of any protected tree, except under a licence granted by the Minister”.</p>	DAFF	<p>A licence is required for the removal of protected trees. It is therefore necessary to conduct a survey that will determine the number and relevant details pertaining to protected tree species present on the project site for the submission of relevant permits to authorities prior to the disturbance of these individuals.</p> <p>The ecological specialist study undertaken as part of the EIA Phase included a site visit which allowed for the identification of any protected tree species which may require a license in terms of the NFA within the project site (refer to Appendix D of the EIA Report). Only one species was recorded that is protected according to the NFA, namely <i>Acacia erioloba</i>.</p>
National Veld and Forest Fire Act (No. 101 of 1998) (NVFFA)	<p>Chapter 4 of the NVFFA places a duty on owners to prepare and maintain firebreaks, the procedure in this regard, and the role of adjoining owners and the fire protection association. Provision is also made for the making of firebreaks on the international boundary of the Republic of South Africa. The applicant must ensure that firebreaks are wide and long enough to have a reasonable chance of preventing a veldfire from spreading to or from neighbouring land, it does not cause soil erosion, and it is reasonably free of inflammable material capable of carrying a veldfire across it.</p> <p>Chapter 5 of the Act places a duty on all owners to acquire equipment and have available personnel to fight fires.</p>	DAFF	<p>While no permitting or licensing requirements arise from this legislation, this Act will be applicable during the construction and operation of the project, in terms of the preparation and maintenance of firebreaks, and the need to provide appropriate equipment and personnel for firefighting purposes.</p>

Legislation	Applicable Requirements	Relevant Authority	Compliance Requirements
	<p>Every owner on whose land a veldfire may start or burn or from whose land it may spread must have such equipment, protective clothing and trained personnel for extinguishing fires; and ensure that in his or her absence responsible persons are present on or near his or her land who, in the event of fire, will extinguish the fire or assist in doing so, and take all reasonable steps to alert the owners of adjoining land and the relevant fire protection association, if any.</p>		
<p>Hazardous Substances Act (No. 15 of 1973) (HAS)</p>	<p>This Act regulates the control of substances that may cause injury, or ill health, or death due to their toxic, corrosive, irritant, strongly sensitising or inflammable nature or the generation of pressure thereby in certain instances and for the control of certain electronic products. To provide for the rating of such substances or products in relation to the degree of danger; to provide for the prohibition and control of the importation, manufacture, sale, use, operation, modification, disposal or dumping of such substances and products.</p> <ul style="list-style-type: none"> » Group I and II: Any substance or mixture of a substance that might by reason of its toxic, corrosive etc., nature or because it generates pressure through decomposition, heat or other means, cause extreme risk of injury etc., can be declared as Group I or Group II substance » Group IV: any electronic product; and » Group V: any radioactive material. <p>The use, conveyance, or storage of any hazardous substance (such as distillate fuel) is prohibited without an appropriate license being in force.</p>	<p>Department of Health</p>	<p>It is necessary to identify and list all Group I, II, III, and IV hazardous substances that may be on site and in what operational context they are used, stored or handled. If applicable, a license would be required to be obtained from the Department of Health (DoH).</p>

Legislation	Applicable Requirements	Relevant Authority	Compliance Requirements
<p>National Environmental Management: Waste Act (No. 59 of 2008) (NEM:WA)</p>	<p>The Minister may by notice in the Gazette publish a list of waste management activities that have, or are likely to have, a detrimental effect on the environment.</p> <p>The Minister may amend the list by –</p> <ul style="list-style-type: none"> » Adding other waste management activities to the list. » Removing waste management activities from the list. » Making other changes to the particulars on the list. <p>In terms of the Regulations published in terms of NEM:WA (GNR 912), a BA or EIA is required to be undertaken for identified listed activities.</p> <p>Any person who stores waste must at least take steps, unless otherwise provided by this Act, to ensure that:</p> <ul style="list-style-type: none"> » The containers in which any waste is stored, are intact and not corroded or in » Any other way rendered unlit for the safe storage of waste. » Adequate measures are taken to prevent accidental spillage or leaking. » The waste cannot be blown away. » Nuisances such as odour, visual impacts and breeding of vectors do not arise; and » Pollution of the environment and harm to health are prevented. 	<p>DEA – hazardous waste</p> <p>North West READ – general waste</p>	<p>No activities are triggered by the project and therefore no Waste Management License is required to be obtained. General and hazardous waste handling, storage and disposal will be required during construction and operation. The National Norms and Standards for the Storage of Waste (GNR 926) published under Section 7(1)(c) of NEM:WA will need to be considered in this regard.</p>
<p>National Road Traffic Act (No. 93 of 1996) (NRTA)</p>	<p>The technical recommendations for highways (TRH 11): "Draft Guidelines for Granting of Exemption Permits for the Conveyance of Abnormal Loads and for other Events on Public Roads" outline the rules and conditions which apply</p>	<p>SANRAL – national roads</p> <p>North West DoT</p>	<p>An abnormal load / vehicle permit may be required to transport the various components to site for construction. These include route clearances and permits will be required for</p>

Legislation	Applicable Requirements	Relevant Authority	Compliance Requirements
	<p>to the transport of abnormal loads and vehicles on public roads and the detailed procedures to be followed in applying for exemption permits are described and discussed.</p> <p>Legal axle load limits and the restrictions imposed on abnormally heavy loads are discussed in relation to the damaging effect on road pavements, bridges, and culverts.</p> <p>The general conditions, limitations, and escort requirements for abnormally dimensioned loads and vehicles are also discussed and reference is made to speed restrictions, power/mass ratio, mass distribution, and general operating conditions for abnormal loads and vehicles. Provision is also made for the granting of permits for all other exemptions from the requirements of the National Road Traffic Act and the relevant Regulations.</p>		<p>vehicles carrying abnormally heavy or abnormally dimensioned loads. Transport vehicles exceeding the dimensional limitations (length) of 22m are considered as abnormal. Depending on the trailer configuration and height when loaded, some of the substation components may not meet specified dimensional limitations (height and width).</p>
Provincial Legislation			
<p>Transvaal Nature Conservation Ordinance (No. 12 of 1983) (TNCO)</p>	<p>The TNCO accompanied by all amendments is regarded by the North West READ as the legally binding, provincial documents, providing regulations, guidelines and procedures with the aim of protecting game and fish, the conservation of flora and fauna and the destruction of problematic (vermin and invasive) species.</p> <p>The TNCO must be considered in its entirety, with special reference to:</p> <ul style="list-style-type: none"> » Schedule 2: Protected Game » Schedule 3: Specially Protected Game » Schedule 4: Protected Wild Animals 	<p>North West READ</p>	<p>In the event that the development of the project results in a prohibited activity occurring with respect to any of the listed Protected Game, Specially Protected Game, Protected Wild Animals, Wild Animals, Invertebrates, Protected Plants, or Specially Protected Plants a permit would be required from READ. The Ecological Impact Assessment (Appendix D of the EIA Report) identified 12 protected plant species protected under the ordinance and relevant for Lichtenburg 2. These species include <i>Gladiolus elliotii</i>, <i>Gladiolus permeabilis</i>, <i>Gladiolus sp.</i>, <i>Crinum graminicola</i>, <i>Crinum</i></p>

Legislation	Applicable Requirements	Relevant Authority	Compliance Requirements
	<ul style="list-style-type: none"> » Schedule 5: Wild Animals » Schedule 7: Invertebrates » Schedule 11: Protected Plants » Schedule 12: Specially Protected Plants 		<p><i>macowanii</i>, <i>Brachystelma foetidum</i>, <i>Brachystelma incanum</i>, <i>Pelargonium dolomiticum</i>, <i>Pelargonium sidoides</i>, <i>Habenaria epipactidea</i> <i>Boophone disticha</i> and <i>Hypoxis hemerocallidea</i>.</p>
<p>Bophuthatswana Nature Conservation Act (No. 03 of 1973) (BNCA)</p>	<p>The BNCA accompanied by all amendments is regarded by the North West READ as the legal binding, provincial documents, providing regulations, guidelines and procedures with the aim of protecting game and fish, the conservation of flora and fauna and the destruction of problematic (vermin and invasive) species.</p> <p>The BNCA must be considered in its entirety, with special reference to:</p> <ul style="list-style-type: none"> » Schedule 1: Protected Game » Schedule 1A: Specially Protected Game » Schedule 2: Ordinary Game » Schedule 3: Wild Animals in Respect of which the Provision of Section 3 (a) (ii) Apply » Schedule 4: Wild Animals to which the Provisions of Section 4 (1) (b) Do Not Apply » Schedule 7: Protected Plants » Schedule 7: Specially Protected Plants 	<p>North West READ</p>	<p>In the event that the development of the project results in a prohibited activity occurring with respect to any of the listed protected game, specially protected game, ordinary game, wild animals in respect of which the provisions of Section 3(a)(ii) apply, wild animals to which the provisions of Section 4(1)(b) do not apply, protected plants, or specially protected plants a permit would be required from READ. The Ecological Impact Assessment (Appendix D of the EIA Report) identified 12 protected plant species protected under the Act relevant for Lichtenburg 2. These include <i>Gladiolus elliotii</i>, <i>Gladiolus permeabilis</i>, <i>Gladiolus sp.</i>, <i>Crinum graminicola</i>, <i>Crinum macowanii</i>, <i>Brachystelma foetidum</i>, <i>Brachystelma incanum</i>, <i>Pelargonium dolomiticum</i>, <i>Pelargonium sidoides</i>, <i>Habenaria epipactidea</i>, <i>Boophone disticha</i> and <i>Hypoxis hemerocallidea</i>.</p>