

HYDROLOGICAL ASSESSMENT FOR THE PROPOSED LESAKA 1 SOLAR ENERGY FACILITY

Version 1

July 2023

HIGHLANDS HYDROLOGY (PTY) LTD

email: luke@wiles.co.za | **phone:** +27 72 129 4202



**HYDROLOGICAL ASSESSMENT FOR THE PROPOSED LESAKA 1
SOLAR ENERGY FACILITY**

Prepared For

SiVEST

Prepared By

Highlands Hydrology (Pty) Ltd

Version 1

July 2023

Executive Summary

Baseline information including monthly rainfall, monthly evaporation, design event rainfall, soils, vegetation and land cover, as well as site topography and regional and local catchment hydrology were considered for the proposed Lesaka 1 Solar Energy Facility located near Loeriesfontein in the Northern Cape Province of South Africa. This baseline confirmed that potential evaporation greatly exceeds rainfall (2673mm versus 199mm respectively). Ground elevations on the site approximate 780mAMSL. Site slopes are mild, with slopes typically below 10%. The site lies within quaternary catchment E31C. The site is drained via a network of non-perennial water courses, expected to flow for short durations following significant rainfall events into the Klein-Rooiberg River, which ultimately contribute to the Berg-Olifants Water Management Area in South Africa. In general terms, the proposed solar project will alter the natural environmental state, thereby affecting the generation of storm water and the associated potential for erosion. Volumes of storm water generated over disturbed areas are generally expected to increase because of the reduction in natural vegetation or the addition of areas of hardstanding resulting from the combination of PV infrastructure and associated pylons, Battery Energy Storage System, the temporary laydown area, the construction area as well as internal access roads. The quality of the storm water generated is also expected to be affected by the removal of vegetation and the excavation of soils. The movement of vehicles over the site will also potentially introduce possible hydrocarbons. A conceptual storm water management plan has been developed for the site aimed at ensuring the impact of water generated upstream or on site during extreme rainfall events can be better managed by routing storm water away from infrastructure thereby reducing any associated flood risk. The approach to sub-catchment delineation was based upon the position of the proposed infrastructure and the natural drainage. The assessment of sub-catchment requiring diversions made use of a 30m Digital Surface Model. A 25ha minimum sub-catchment area was used as the area above which individual sub-catchments were identified as having concentrated runoff with the recommendation that storm water management be included. A hydrological impact assessment was undertaken to determine the significance of each identified potential impact according to impact probability, frequency, extent, duration and intensity. Potential impacts considered in this assessment for the construction and operational phases were changes in catchment water resources, changes in catchment water quality, and changes in flood hydrology. The assessment further considered appropriate mitigation techniques which should be adopted in order to reduce impact significance. Potential significance for the considered impacts ranged from medium in the pre-mitigation scenarios to low in the post mitigation scenarios.

TABLE OF CONTENTS

LIST OF FIGURES.....	5
LIST OF TABLES.....	6
SPECIALIST REPORT REQUIREMENT CHECKLIST (AS PER APPENDIX 6 OF GNR 982).....	7
1 INTRODUCTION	9
1.1 BACKGROUND.....	9
1.2 SCOPE OF WORK	9
1.3 REGIONAL SETTING AND LAYOUT	9
2 BASELINE INFORMATION	12
2.1 RAINFALL.....	12
2.2 1-DAY DESIGN RAINFALL DEPTHS.....	14
2.3 EVAPORATION.....	14
2.4 AVERAGE CLIMATE	15
2.5 TERRAIN	15
2.6 HYDROLOGY.....	16
2.7 SOILS, VEGETATION AND LAND-COVER.....	18
3 STORM WATER MANAGEMENT	21
3.1 AREAS REQUIRING STORM WATER MANAGEMENT.....	21
3.1.1 <i>HYDROLOGICAL EFFECT OF SOLAR FARMS</i>	22
3.1.2 <i>MANAGEMENT APPROACH</i>	22
3.1.3 <i>SUB-CATCHMENT AREAS</i>	23
3.2 FUELS, LUBRICANTS AND CHEMICALS.....	23
3.3 STORM WATER MANAGEMENT INFRASTRUCTURE.....	23
3.3.1 <i>AVAILABLE INFORMATION</i>	25
3.3.2 <i>DIVERSIONS</i>	25
3.4 EROSION CONTROL	27
3.4.1 <i>SILT FENCES</i>	27
3.4.2 <i>SILT TRAPS</i>	28
4 HYDROLOGICAL IMPACT ASSESSMENT.....	30
4.1 HYDROLOGICAL IMPACT ASSESSMENT METHODOLOGY	30
4.1.1 <i>RATING SCALES APPLIED DURING THE IMPACT ASSESSMENT</i>	31
4.1.2 <i>METHODOLOGY USED IN DETERMINING THE SIGNIFICANCE OF IMPACTS</i>	33
4.1.3 <i>SOURCE – PATHWAY – RECEPTOR MODEL</i>	34
4.2 ASSESSMENT OF THE IMPACTS FROM THE PROPOSED DEVELOPMENT	36

4.2.1	CONSTRUCTION PHASE	36
4.2.2	OPERATIONAL PHASE	37
4.2.3	DECOMMISSIONING PHASE	38
4.3	HYDROLOGICAL IMPACT SIGNIFICANCE AND MITIGATION MEASURES	39
4.3.1	CHANGES IN WATER RESOURCES	46
4.3.2	REDUCTION IN WATER QUALITY	46
4.3.3	CHANGES IN FLOOD HYDROLOGY	47
5	CONCLUSIONS AND RECOMMENDATIONS	48
6	REFERENCES	53
APPENDIX A: STORM WATER CALCULATIONS		54
A.1	MODEL CHOICE	54
A.2	DESIGN HYDROGRAPHS	54
A.2.1	DESIGN STORM	54
A.2.2	MODEL PARAMETERISATION	54
A.2.2	MODEL RUN	54
APPENDIX B: CURRICULUM VITAE		56

LIST OF FIGURES

FIGURE 1-1: REGIONAL SETTING	10
FIGURE 1-2: LAYOUT	11
FIGURE 2-1: WEATHER STATIONS AND MEAN ANNUAL PRECIPITATION	13
FIGURE 2-2: AVERAGE MONTHLY CLIMATE FOR THE SITE	15
FIGURE 2-3: TERRAIN AND HYDROLOGY	17
FIGURE 2-4: VEGETATION, SOILS AND RUNOFF POTENTIAL	19
FIGURE 2-5: LAND COVER	20
FIGURE 3-1: STORM WATER MANAGEMENT PLAN	24
FIGURE 3-2: TYPICAL BERM AND CHANNEL FOR STORM WATER DIVERSION SYSTEM	25
FIGURE 3-3: TYPICAL SILT FENCE (AFTER ENVIRONMENT PROTECTION AGENCY)	28

LIST OF TABLES

TABLE 2-1: AVERAGE MONTHLY RAINFALL DISTRIBUTION (MM)	12
TABLE 2-2: DRESSA 24-HOUR RAINFALL DEPTH.....	14
TABLE 2-3: MONTHLY A-PAN EQUIVALENT POTENTIAL EVAPORATION	14
TABLE 3-1: DIMENSIONS FOR DIVERSIONS AND NATURAL CHANNELS	26
TABLE 3-2: SILT TRAP INFLOW VOLUME (1:10 RI, 24-HOUR EVENT).....	29
TABLE 4-1: RATING ASSESSMENT CLASSIFICATION	31
TABLE 4-2: SIGNIFICANCE RATINGS	33
TABLE 4-3: SIGNIFICANCE RATINGS OF POTENTIAL IMPACTS.....	40
TABLE 5-1: KEY MONITORING RECOMMENDATIONS FOR THE CONSTRUCTION PHASE.....	50
TABLE 5-2: KEY MONITORING RECOMMENDATIONS FOR THE OPERATIONAL PHASE.....	51
TABLE 5-3: KEY MONITORING RECOMMENDATIONS FOR THE DECOMMISSIONING PHASE.....	52
TABLE A-0-1: SUB-CATCHMENT CHARACTERISTICS FOR THE 1:50 YEAR EVENT UNLESS INDICATED.....	55

SPECIALIST REPORT REQUIREMENT CHECKLIST (AS PER APPENDIX 6 OF GNR 982)

Regulation GNR 326 of 4 December 2014, as amended 7 April 2017, Appendix 6	Section of Report
(a) details of the specialist who prepared the report; and the expertise of that specialist to compile a specialist report including a <i>curriculum vitae</i> ;	Page 56
(b) a declaration that the specialist is independent in a form as may be specified by the competent authority;	Separate document
(c) an indication of the scope of, and the purpose for which, the report was prepared;	Page 9
(cA) an indication of the quality and age of base data used for the specialist report;	Page 12-20
(cB) a description of existing impacts on the site, cumulative impacts of the proposed development and levels of acceptable change;	Page 30-47
(d) the duration, date and season of the site investigation and the relevance of the season to the outcome of the assessment;	Page 9
(e) a description of the methodology adopted in preparing the report or carrying out the specialised process inclusive of equipment and modelling used;	Page 9
(f) details of an assessment of the specific identified sensitivity of the site related to the proposed activity or activities and its associated structures and infrastructure, inclusive of a site plan identifying site alternatives;	Page 11 and 24
(g) an identification of any areas to be avoided, including buffers;	Page 24
(h) a map superimposing the activity including the associated structures and infrastructure on the environmental sensitivities of the site including areas to be avoided, including buffers;	Page 24
(i) a description of any assumptions made and any uncertainties or gaps in knowledge;	Page 15, 22, 23
(j) a description of the findings and potential implications of such findings on the impact of the proposed activity, including identified alternatives on the environment or activities;	Page 30-47
(k) any mitigation measures for inclusion in the EMPr;	Page 30-47, 50-52
(l) any conditions for inclusion in the environmental authorisation;	Page 30-47, 50-52
(m) any monitoring requirements for inclusion in the EMPr or environmental authorisation;	Page 49-52
(n) a reasoned opinion— i. whether the proposed activity, activities or portions thereof should be authorised; iA. Regarding the acceptability of the proposed activity or activities; and ii. if the opinion is that the proposed activity, activities or portions thereof should be authorised, any avoidance, management and mitigation measures that should be included in the EMPr or Environmental Authorization, and where applicable, the closure plan;	Page 52
(o) a summary and copies of any comments received during any consultation process and where applicable all responses thereto; and	N/A

(p) any other information requested by the competent authority	N/A
(2) Where a government notice gazetted by the Minister provides for any protocol or minimum information requirement to be applied to a specialist report, the requirements as indicated in such notice will apply.	N/A

HYDROLOGICAL ASSESSMENT FOR THE PROPOSED LESAKA 1 SOLAR ENERGY FACILITY

1 INTRODUCTION

1.1 BACKGROUND

Highlands Hydrology (Pty) Ltd was appointed by SiVEST on behalf of Lesaka 1 Solar Energy Facility (Pty) Ltd to undertake a hydrological assessment for the proposed Lesaka 1 Solar Energy Facility located near Loeriesfontein in the Northern Cape Province of South Africa. The aim of the assessment was to develop a conceptual storm water management plan and associated hydrological impact assessment.

1.2 SCOPE OF WORK

The scope of work for the hydrological assessment included the following deliverables:

- *Site Examination* – the site was visited by Luke Wiles (a registered hydrologist), on the 28th of June 2023. This was to enable a better understanding of the dominant hydrological flow regimes and to confirm various model inputs;
- *Baseline Assessment* – baseline climatic and hydrological data were sourced for the site. This included the interrogation of rainfall data, site specific design rainfall (depth/duration/frequency), evaporation, soils, natural vegetation, land-cover, as well as a regional and local hydrology;
- *Storm Water Management Assessment* – develop a storm water model and associated conceptual storm water management plan for the site using the PCSWMM model package; and
- A technical report detailing the achieved scope of work, illustrated through GIS mapping.

1.3 REGIONAL SETTING AND LAYOUT

The proposed Lesaka 1 site is located at approximately 30° 36' 50" S, 19° 28' 49" E Figure 1-1 illustrates the regional setting of the proposed site, while Figure 1-2 presents the layout of proposed infrastructure at the site.

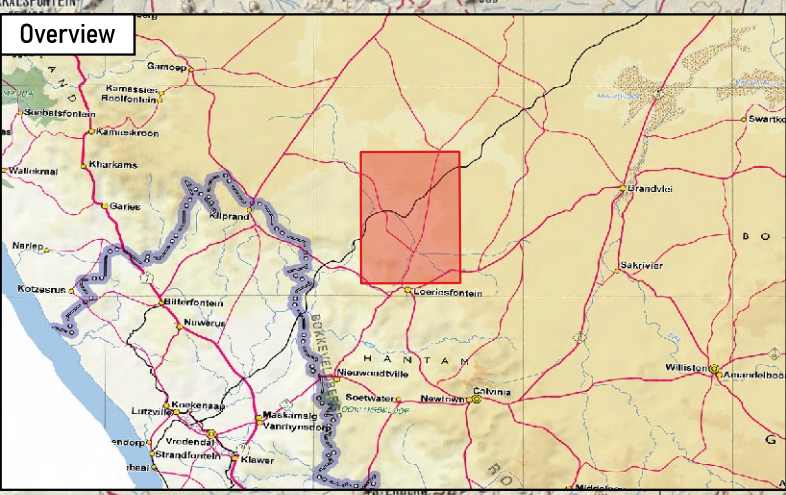
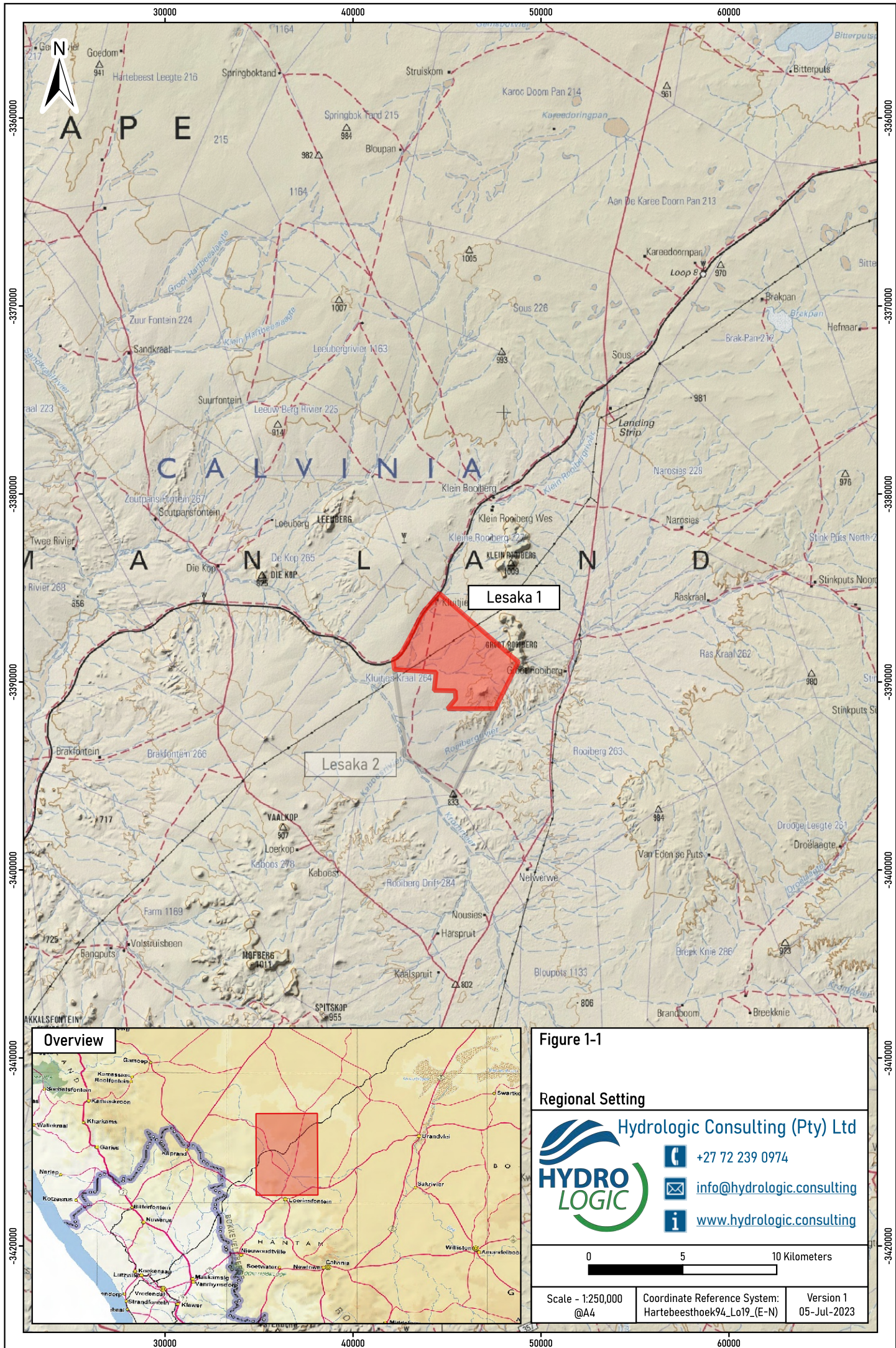



Figure 1-1

Regional Setting

Hydrologic Consulting (Pty) Ltd

 +27 72 239 0974
 info@hydrologic.consulting
 www.hydrologic.consulting

0 5 10 Kilometers

Scale - 1:250,000 @A4	Coordinate Reference System: Hartebeesthoek94_Lo19_(E-N)	Version 1 05-Jul-2023
-----------------------	--	-----------------------

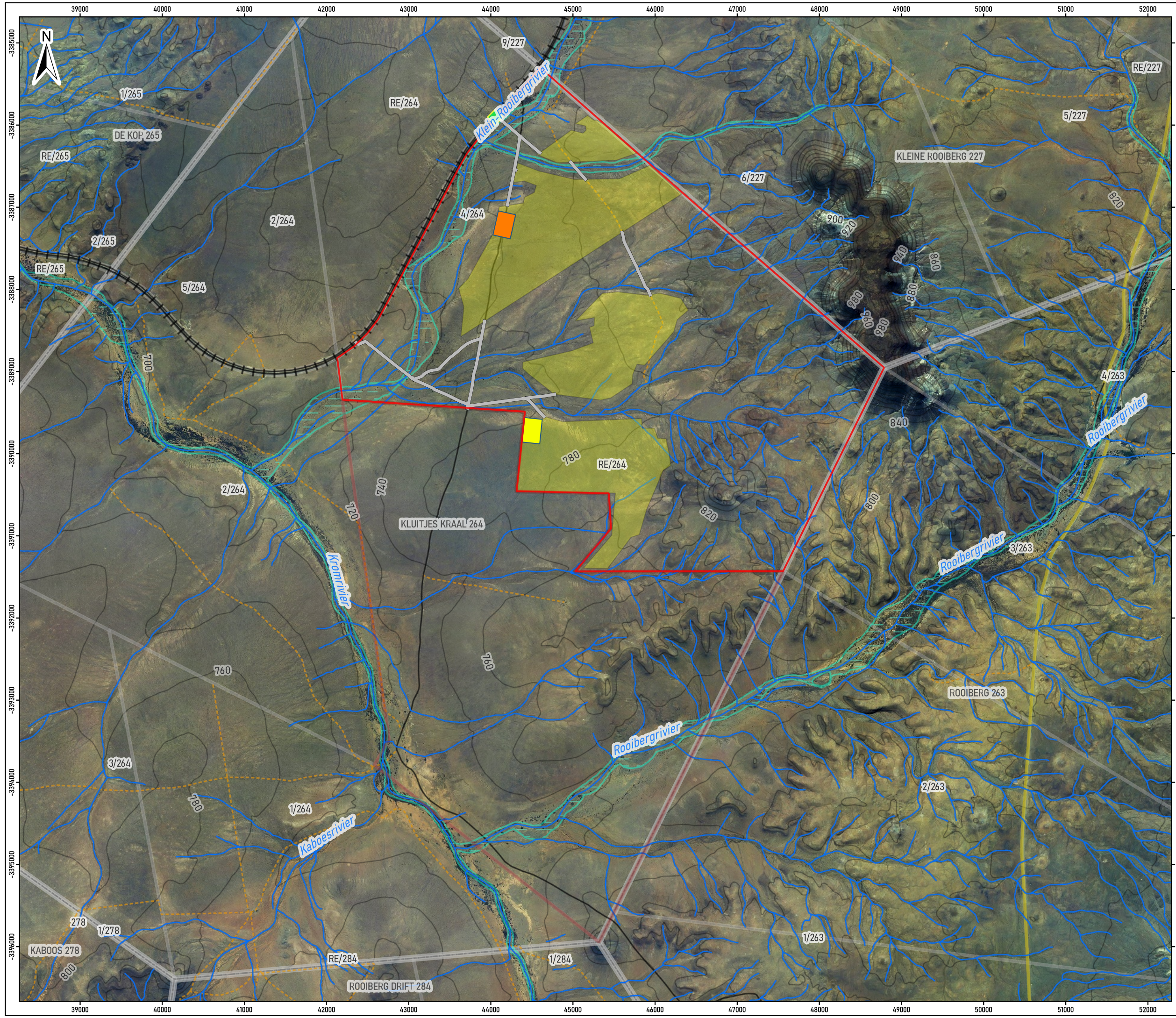

Legend

- Lesaka 1
- Lesaka 2
- ◆ Access Point
- Access Roads
- Substation and BESS
- Temporary Laydown and Construction Area
- Buidable Area
- Railway (50K Topo)
- Non-Perennial River (50K Topo)
- Dam (50K Topo)
- Dry Water Course (50K Topo)
- Footpath (50K Topo)
- Other Road (50K Topo)
- Secondary Road (50K Topo)
- Parent Farm
- Farm Portion
- 20m Contours (50K Topo)

Figure 1-2

Layout

Hydrologic Consulting (Pty) Ltd

+27 72 239 0974
 info@hydrologic.consulting
 www.hydrologic.consulting

Scale - 1:43,000	Coordinate Reference System: Hartebeesthoek94_Lo19_(E-N)	Version 1 07-Jul-2023
------------------	--	--------------------------

2 BASELINE INFORMATION

Baseline information in this section includes rainfall, evaporation, design event rainfall, soils, vegetation and land-cover, as well regional and local topography hydrology.

2.1 RAINFALL

Weather stations managed by both the South African Weather Services (SAWS) and the Department of Water and Sanitation (DWS) are considered for hydrological assessments such as this and have been illustrated in Figure 2-1. The closest SAWS station to the site is SAWS station 160807 A (Loeriesfontein- Pol) located approximately 36km south of the site and has an altitude of 885m above mean sea level with the site having an altitude of approximately 780m above mean sea level. This SAWS station has a record length of at least 82 years with a Mean Annual Precipitation (MAP) of 202mm. There are no DWS rainfall stations in close proximity to the site.

The potential for rainfall distributions to change over distance can be significant as illustrated in Figure 2-1, presenting the variation in mean annual precipitation (MAP) in the greater area. Due to the distance of the site from the nearest SAWS station and any potential error which may be associated with the data at that station, an alternative and site-specific source of rainfall data was used to provide average monthly rainfall values for the actual site as per Pegram *et al* (2016). This eliminates any risk associated with relying on a single rainfall station which may or may not be representative of the site.

Pegram *et al* (2016) includes details on the development of a raster database of monthly rainfall data for Southern Africa. Table 2-1 presents the site specific average monthly rainfall estimates from Pegram *et al* (2016) indicating a MAP of 199mm, comparing well to the distribution of rainfall as illustrated in Figure 2-1, as well as SAWS station 160807 A (202mm). Table 2-1 presents the average monthly rainfall estimates from Pegram *et al* (2016) for the site.

TABLE 2-1: AVERAGE MONTHLY RAINFALL DISTRIBUTION (MM)

Month	Pegram et al. (2016)
Jan	13
Feb	16
Mar	25
Apr	16
May	17
Jun	18
Jul	16
Aug	14
Sep	16
Oct	16
Nov	17
Dec	15
Total	199

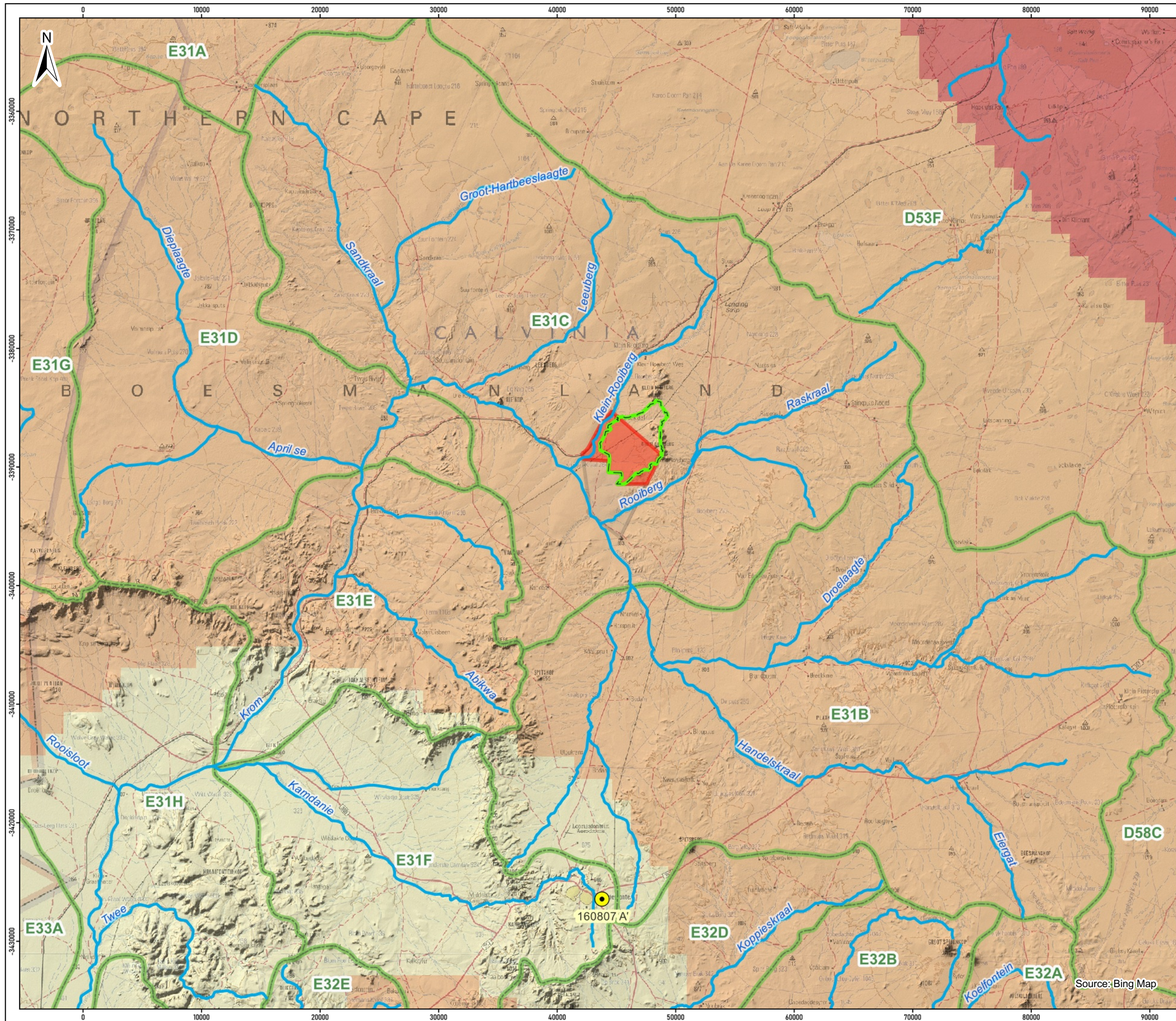

Legend

- Lesaka 1
- Raingauges**
- SAWS
- DWS
- Rivers (500K Topo)
- Dams (500K Topo)
- Quaternary Catchments
- Containing Catchment (30m DSM Derived)
- Mean Annual Precipitation (mm)**
- <= 150
- 150 - 200
- 200 - 250
- 250 - 300
- > 300

Figure 2-1
Weather Stations and Mean Annual Precipitation

Hydrologic Consulting (Pty) Ltd

 +27 72 239 0974
 info@hydrologic.consulting
 www.hydrologic.consulting

Scale - 1:300,000 @A3
 Coordinate Reference System: Hartebeesthoek94_Lo19_(E-N)
 Version 1 07-Jul-2023

Source: Bing Map

2.2 1-DAY DESIGN RAINFALL DEPTHS

Design rainfall estimates for various recurrence intervals and durations were sourced from the Design Rainfall Estimation Software for South Africa (DRESSA), developed by the University of Natal in 2002 as part of WRC project K5/1060 (WRC, 2002). This method uses a regional I-moment algorithm in conjunction with a scale invariance approach to provide site-specific estimates of design rainfall (depth, duration and frequency), based on surrounding station records. WRC (2002) provides more detail on this method of design rainfall estimation. Table 2-2 presents the average DRESSA design rainfall estimates for the site.

TABLE 2-2: DRESSA 24-HOUR RAINFALL DEPTH

Recurrence Interval (Years)	Rainfall Depth (24 hour) (mm)
2	32
5	45
10	54
20	64
50	77
100	87
200	98

It is important to note, that no allowances for climate change was included in this study. A risk analysis using the expected life of a structure or process will indicate the relevance of considering climate change (i.e. as the expected life increases the influence of climate change increases).

2.3 EVAPORATION

Evaporation data was sourced from the South African Atlas of Climatology and Agrohydrology (Schulze and Lynch, 2006) in the form of A-Pan equivalent potential evaporation. The average monthly evaporation distribution is presented in Table 2-3 and shows an annual potential evaporation of 2673mm.

TABLE 2-3: MONTHLY A-PAN EQUIVALENT POTENTIAL EVAPORATION

Month	Schulze & Lynch (2006)
Jan	368
Feb	297
Mar	254
Apr	168
May	126
Jun	93
Jul	103
Aug	142
Sep	194
Oct	252
Nov	312
Dec	364
Total	2,673

2.4 AVERAGE CLIMATE

The average climate for the site is presented in Figure 2-2. While evaporation is illustrated as greatly exceeding rainfall, this is representative of the maximum A-Pan equivalent potential evaporation that could occur assuming no limitations are placed on evaporative demand. The combination of rainfall, evaporation and temperature result in a hot arid steppe climate according to the Köppen-Geiger climate classification¹.

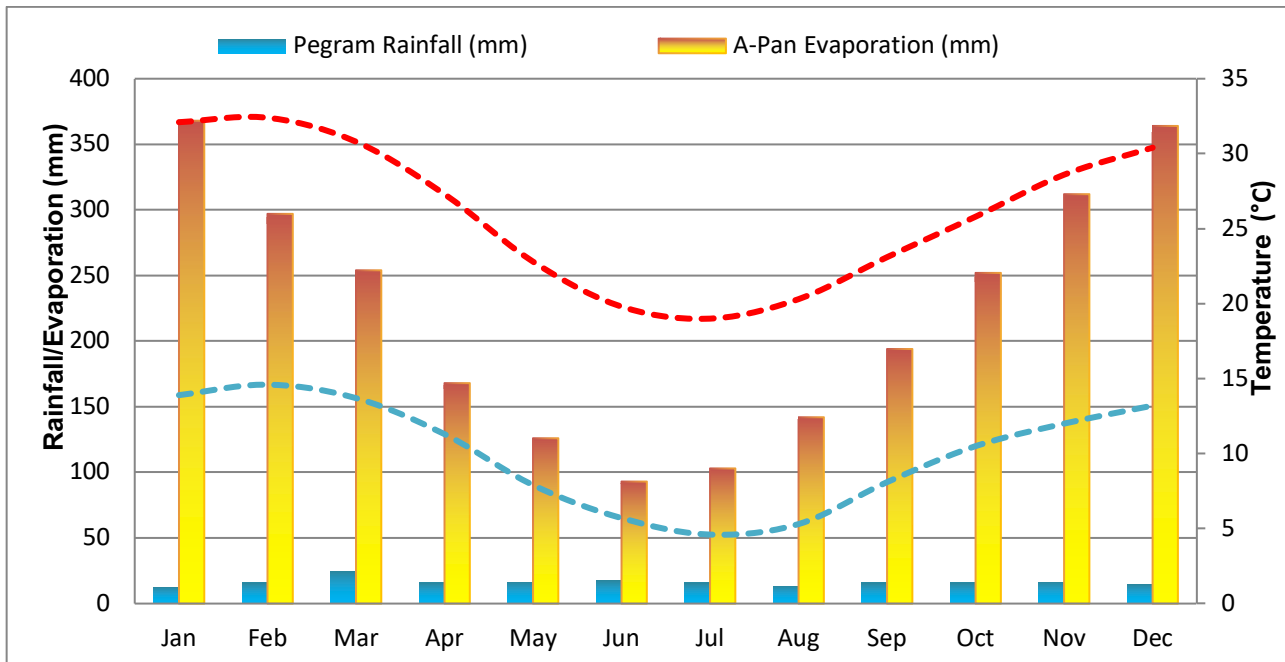

FIGURE 2-2: AVERAGE MONTHLY CLIMATE FOR THE SITE

2.5 TERRAIN

Two terrain datasets were used to assess the terrain of the site and surrounds, namely:

1. A 30m DSM global digital surface model (DSM)²;
2. National Geospatial Institute (NGI) 20m contours.

The 30m DSM was the most detailed dataset available at the time of the study. This dataset provides a coarse understanding of terrain as it provides a 30x30m resolution with a 1m vertical interval. Based upon the development of the storm water model (per Section 3), the 30m DSM is considered reasonable in enabling a high-level understanding of terrain for the SWMP to be developed, based on the total buildable footprints at the site. Ground elevations on the site approximate 780mAMSL. Site slopes are mild, with slopes typically below 10%. The NGI's 20m contours provide a generalised understanding of the terrain of the site and its surroundings.

¹ http://stepsa.org/climate_koppen_geiger.html

² <https://www.eorc.jaxa.jp/>

2.6 HYDROLOGY

Figure 2-3 illustrates the hydrological setting of the site, while Figure 2-1 presents the river network of the greater region. The site lies within quaternary catchment E31C. A containing catchment derived from the 30m DSM has also been illustrated in Figure 2-3 (23.43km²) outlining the catchment of relevance to this study (i.e. the catchment area contributing to flows at the site). The NGI's 1:50,000 topographical map data as well as derived 30m DSM indicate that the site is drained via a network of non-perennial water courses, expected to flow for short durations following significant rainfall events into the Klein-Rooiberg River, which ultimately contribute to the Berg-Olifants Water Management Area in South Africa.

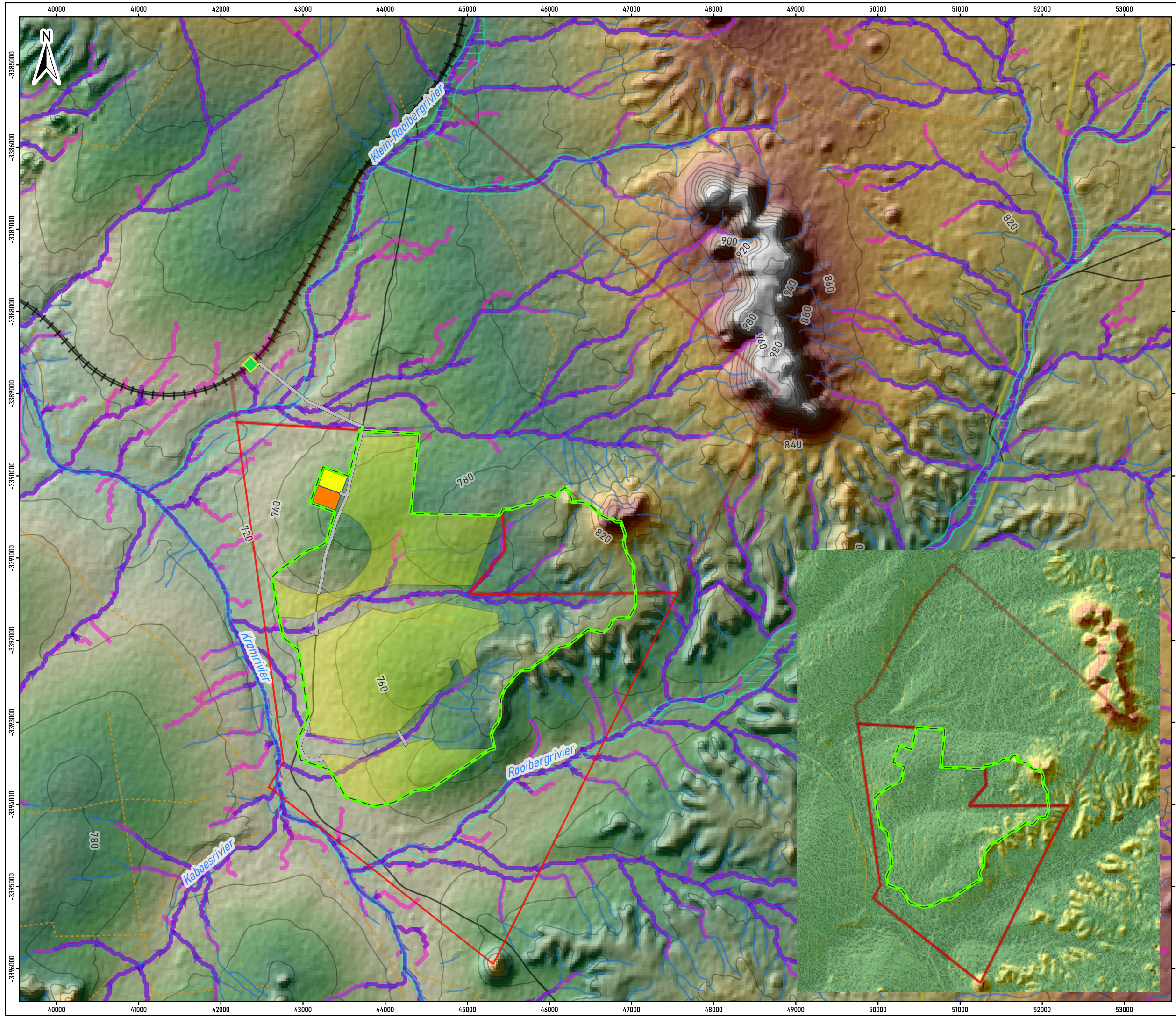

Legend

- Lesaka 2
- Lesaka 1
- ◆ Access Point
- Access Roads
- Substation and BESS
- Temporary Laydown and Construction Camp
- Buildable Area
- Railway (50K Topo)
- Containing Catchment
- Non-Perennial River (50K Topo)
- Dam (50K Topo)
- Dry Water Course (50K Topo)
- Footpath (50K Topo)
- Other Road (50K Topo)
- Secondary Road (50K Topo)
- 20m Contours (50K Topo)
- Contributing Area >50ha (30m DSM Derived)
- Contributing Area >25ha (30m DSM Derived)

Elevation (mAMSL - AW3D30)

- 1,010
- 705

Percentage Slope

- <= 3
- 3 - 10
- 10 - 30
- 30 - 50
- > 50

Figure 2-3

Terrain and Hydrology

Hydrologic Consulting (Pty) Ltd

HYDRO LOGIC

+27 72 239 0974
 info@hydrologic.consulting
 www.hydrologic.consulting

0 500 1,000 1,500 2,000 2,500 m

Scale - 1:43,000
 @A3
 Coordinate Reference System: Hartebeesthoek94_Lo19_(E-N)
 Version 1
 07-Jul-2023

2.7 SOILS, VEGETATION AND LAND-COVER

According to the high-level soils data included in the Water Resources of South Africa 2012 (WR2012) study (Bailey and Pitman, 2015), soils on site are classified sands to loams. In considering the more detailed Soil Conservation Service for South Africa (SCS-SA) dataset of the site, soils fall within hydrological soil group B (moderately low runoff potential) to the west of the site and hydrological soil group C (moderately high runoff potential) to the east of the site. The natural vegetation of the site is classified Hantam Karoo (succulent karoo vegetation) according to SANBI (2018). Land-cover of the site is mostly classified as 'barren land' according to the Department of Environmental Affairs (DEA) 2020 dataset. There are minor areas of 'shrubland' present with near negligible areas of 'forested land'. During the site visit it was confirmed that whilst vegetation is sparse, there is indeed the presence of shrubs and grasses across the site. Figure 2-4 presents the distribution of the SCS soil types (runoff potential) and natural vegetation while the land-cover in the region about the site is illustrated in Figure 2-5.

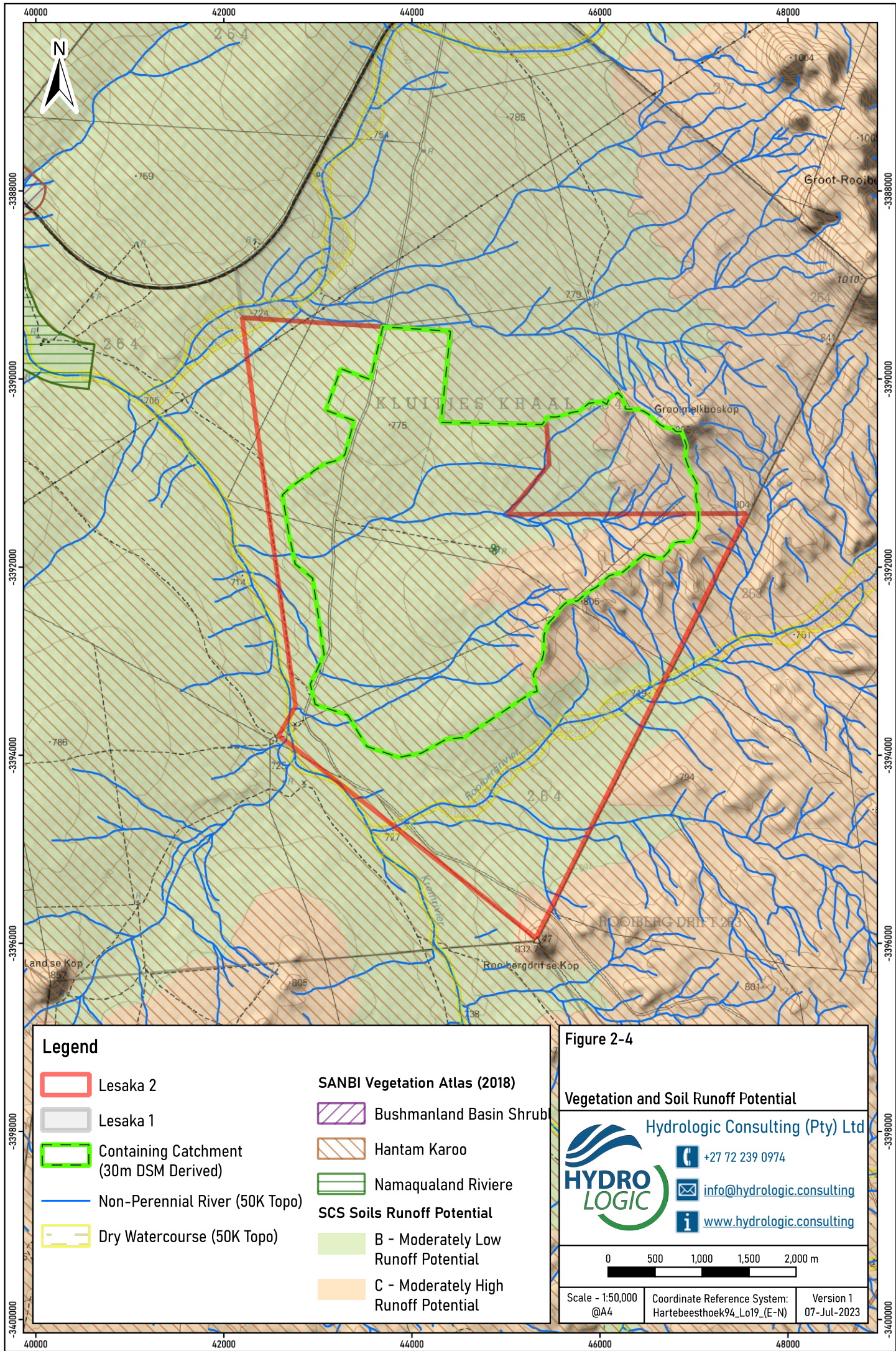

Legend

Lesaka 2

Lesaka 1

Containing Catchment (30m DSM Derived)

Non-Perennial River (50K Topo)

Dry Watercourse (50K Topo)

SANBI Vegetation Atlas (2018)

Bushmanland Basin Shrub

Hantam Karoo

Namaqualand Riviere

SCS Soils Runoff Potential

B - Moderately Low Runoff Potential

C - Moderately High Runoff Potential

Figure 2-4

Vegetation and Soil Runoff Potential

Hydrologic Consulting (Pty) Ltd

HYDRO LOGIC

+27 72 239 0974

info@hydrologic.consulting

www.hydrologic.consulting

0 500 1,000 1,500 2,000 m

Scale - 1:50,000
@A4

Coordinate Reference System:
Hartebeesthoek94_Lo19_(E-N)

Version 1
07-Jul-2023

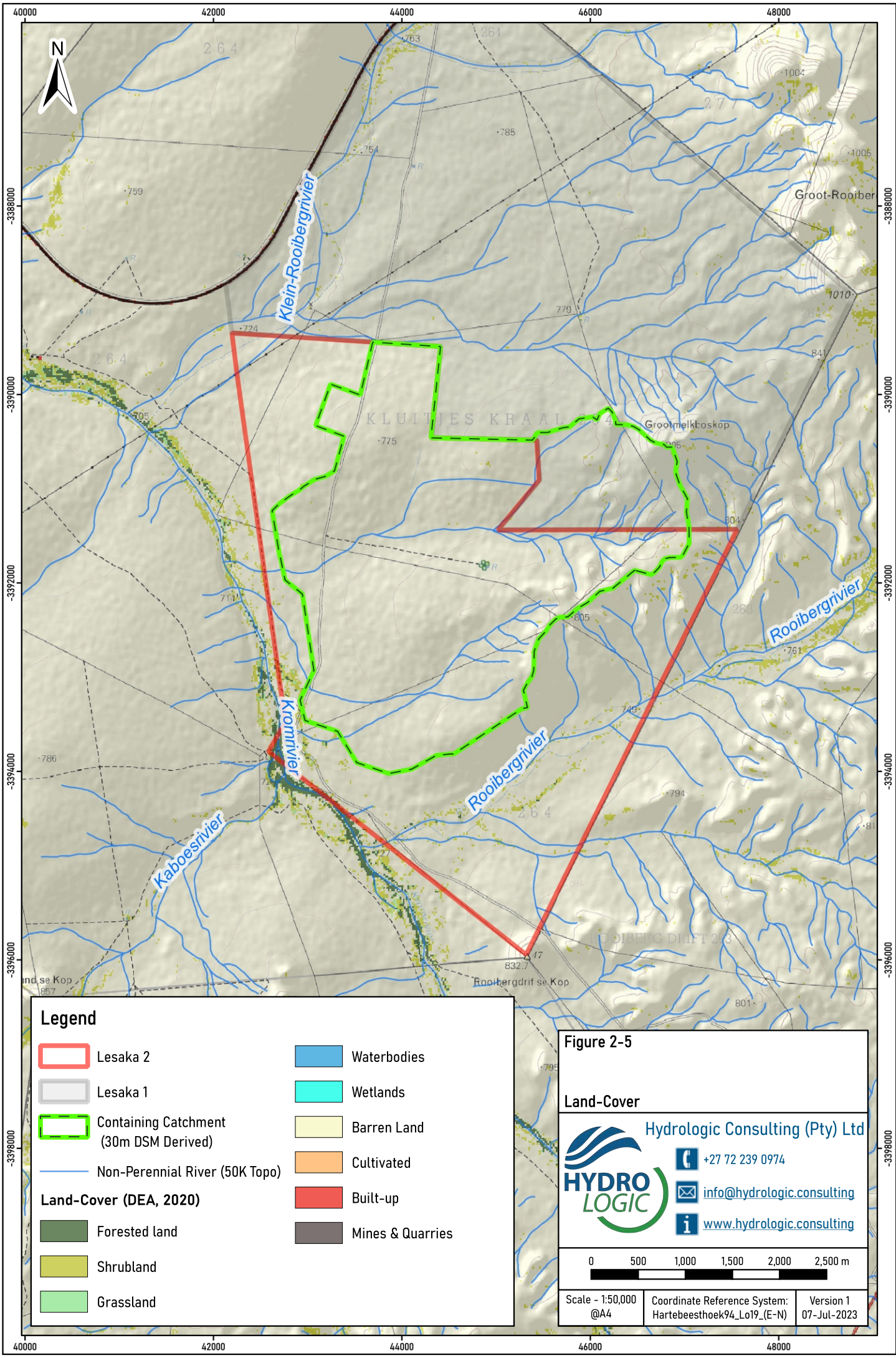

Legend













- | | |
|--|--|
|  Lesaka 2 |  Waterbodies |
|  Lesaka 1 |  Wetlands |
|  Containing Catchment (30m DSM Derived) |  Barren Land |
|  Non-Perennial River (50K Topo) |  Cultivated |
| Land-Cover (DEA, 2020) |  Built-up |
|  Forested land |  Mines & Quarries |
|  Shrubland | |
|  Grassland | |

Figure 2-5

Land-Cover

Hydrologic Consulting (Pty) Ltd

 +27 72 239 0974
 info@hydrologic.consulting
 www.hydrologic.consulting

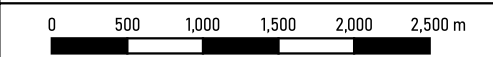

Scale - 1:50,000 @A4 Coordinate Reference System: Hartebeesthoek94_Lo19_(E-N) Version 1 07-Jul-2023

3 STORM WATER MANAGEMENT

The proposed solar project will alter the natural environmental state, thereby affecting the generation of storm water and the associated potential for erosion. Volumes of storm water generated over disturbed areas are generally expected to increase because of the reduction in natural vegetation or the addition of areas of hardstanding. The quality of the storm water generated is also expected to be affected by the removal of vegetation and excavation of soils (i.e. potential erosion will increase). The movement of vehicles over the site will also introduce possible hydrocarbons, however, this section does not deal with possible chemical pollutants (focusing instead on potentially increased sediment loads with regards to water quality).

The purpose of this section is to consider storm water management on site and to propose suitable erosion control measures by which potential erosion can be limited.

Relevant guidance that informs the above includes the following:

- National Environmental Management Act (Act No. 107 of 1998) as amended, which states that “Every person who causes, has caused or may cause significant pollution or degradation of the environment must take reasonable measures to prevent such pollution or degradation from occurring, continuing or recurring...”
- National Water Act (Act No. 36 of 1998) includes Section 21 water uses which require authorisation from the Department of Water and Sanitation (DWS).
- Government Notice 704 (Government Gazette 20118 of June 1999), which while it focuses on mining, includes some important principles by which clean and dirty water producing areas can be managed effectively;
- Department of Water and Sanitation (DWS) Best Practice Guideline G1 for Storm water Management;
- Landcom Soils and Construction, Volume 1, 4th edition from 2004 (otherwise known as the Blue Book) has been used widely in the South African context in providing practical recommendations regarding the management of storm water and associated erosion controls; and
- The South African Roads Agency Limited (SANRAL) 6'th edition Drainage Manual (2013) provides some valuable insight specific to the construction and operation of various roads, a network of which will be developed as part of this proposed project.

3.1 AREAS REQUIRING STORM WATER MANAGEMENT

In considering the site, some hardstanding areas are proposed in the form of the substation/BESS, temporary laydown area/construction camp and solar panel pylons (specifically their foundations). The solar panels themselves do not qualify as hardstanding since they do not limit infiltration beneath them. Some compaction of soils on site is expected, particularly with regards to areas of travel, such as the internal access roads and laydown area. Site access roads are also proposed although these are expected to be gravel and while compaction may occur, they will not be fully impervious.

The development of the solar farm will likely be associated with a limited change to the natural land-cover when the full site is considered, assuming disturbed land-cover (i.e. soils and vegetation) is rehabilitated. The implication of this rehabilitation (of the areas between panel foundations), is that most of the site can retain a naturalised hydrological response where both the quantity and quality of storm water is similar to the natural baseline

environment. This does not consider solar panel washing or other maintenance that may introduce pollutants such as hydrocarbons.

Soils on and surrounding the site are expected to have moderately low to moderately high runoff potential (SCS soil group B and C). Combined with the flat terrain and low rainfall of the region, runoff is only expected to occur during storms. The dominant occurrence of sparse vegetation in a desert climate means that areas of poor vegetation coverage are possible (i.e. bare areas). These areas would increase the potential for runoff due to the absence of vegetation that may otherwise slow down runoff (and promote infiltration).

3.1.1 HYDROLOGICAL EFFECT OF SOLAR FARMS

A study by Cook and McCuen (2013) is of relevance to this report as it describes the hydrological effect of solar farms and whether storm water management is required to control runoff rates and volumes. This study considered a solar farm before and after the installation of panels. The study found that the solar panels did not have a significant effect on existing runoff rates, runoff volumes or time to peak of runoff. The presence of gravel or bare ground under the panels could, however, significantly increase the amount of runoff generated, while the kinetic energy of runoff falling from panels was a possible cause of erosion (at the base of panels). The study recommended that the grass beneath the panels be well maintained or that a buffer strip be placed after the most downgradient row of panels. Gravel strips are consequently only recommended below panels where grass cannot be cultivated (to limit possible increased erosivity of runoff falling from panels).

3.1.2 MANAGEMENT APPROACH

Figure 3-1 presents the conceptual storm water management plan for the Lesaka 1 site. It is important to note that the Lesaka 1 and Lesaka 2 projects are not hydrologically independent of each other and as such, the SWMPs should be viewed in this context.

The 30m DSM was used in the delineation of sub-catchments. This DSM is not detailed and some inaccuracy in delineation is expected. Based upon the development of the storm water model, the 30m DSM is nevertheless considered reasonable in enabling a high-level understanding of terrain since the final layout for the site is not yet available with the SWMP based upon the buildable area (and thereby only indicative of necessary storm water management).

Diverting upslope areas (generating run-on) around the site, was adopted to limit the potential management of storm water within the site. Per Figure 2-3, a 50ha minimum sub-catchment area initially informed an approach whereby diversions (to route storm water) within the buildable area proposed, given the potentially significant volume and rate of runoff (from a contributing area larger than 50ha). This 50ha threshold was revised to 25ha once it was noted that a 50ha left the majority of the site as 'unmanaged', were the 50ha threshold retained. The 25ha threshold is, however, not a limitation to the addition or reduction in the proposed diversions and this threshold should be reviewed during the detailed design phase. It is recommended that diversions incorporate soft engineering approaches with swales being an option that would likely integrate well with the recommended diversions. The aforementioned utilised the 1:50 year RI event for design purposes.

Beyond the PV array area (to be developed within the buildable area illustrated in Figure 3-1), the substation/BESS and temporary laydown area/construction camp are two specific areas of more intense development where the addition of hardstanding is likely to be greater and where disturbance of the current landscape is potentially more

significant than for the greater PV array. These two areas have been conceptually managed using diversions that route internal runoff to a silt trap. Final design may adopt an alternate approach. Silt management was based upon the 1:10 year RI event.

Buffer strips are proposed downslope of panel 'blocks', however, this current phase of assessment does not have an array layout on which to base the location of buffer strips. These buffer strips are envisaged as well vegetated areas (ideally continuous grass cover) that will assist in the slowing down of runoff, and the promotion of infiltration. The natural land-cover and drainage of the site should be retained insofar as is possible (as a general guideline).

3.1.3 SUB-CATCHMENT AREAS

The assessment of sub-catchment requiring diversions made use of the 30m DSM. A 25ha minimum sub-catchment area was used as the area above which individual sub-catchments were identified as having concentrated runoff with the recommendation that storm water management be included – through the addition of a diversion. The majority of the site (to be developed) had sub-catchments with an area below 25ha and were identified as having distributed runoff without the need for formal storm water management. Furthermore, the area associated with the substation/BESS and temporary laydown area/construction camp was classified as requiring silt management given the more concentrated development expected over this area (and the associated increased disturbance).

Lastly, areas that are not to be developed within the site but that received runoff from the aforementioned catchments prior to routing this runoff past the developable area were included as natural sub-catchments. This enables the assessment of the combined rainfall-runoff response for the non-perennial rivers intersecting the site which may be of value with regards to the sizing of river crossings or with regards to anticipating the peak flows that might be generated (for the 1:50 RI event).

The results of this process of sub-catchment classification are illustrated in Figure 3-1. As this is a conceptual SWMP, this report does not present the definitive SWMP for the site, which may see value in additional drainage channels to the site, particularly once the PV array layout is known.

3.2 FUELS, LUBRICANTS AND CHEMICALS

The storage/handling of fuel, lubricants and chemicals will require special attention due to their hazardous nature as is the case with the laydown areas. These areas are required to be managed on impermeable floors with appropriate bunding, sumps and roofing. This is regarded as localised management and does not form part of this conceptual SWMP.

3.3 STORM WATER MANAGEMENT INFRASTRUCTURE

Figure 3-1 illustrates the conceptual SWMP while Appendix A presents details relating to the development of the SWMP using PCSWMM, which is based on the Storm Water Management Model (Rossman, 2008). Storm water management infrastructure has been conceptually designed using the 1:50 year, 24-hour RI event except for sediment control areas that have utilised the 1:10 year RI event. No account has been taken of climate change and any potential future increases in rainfall depth or intensity. These will need to be considered depending on the expected life of the structure.

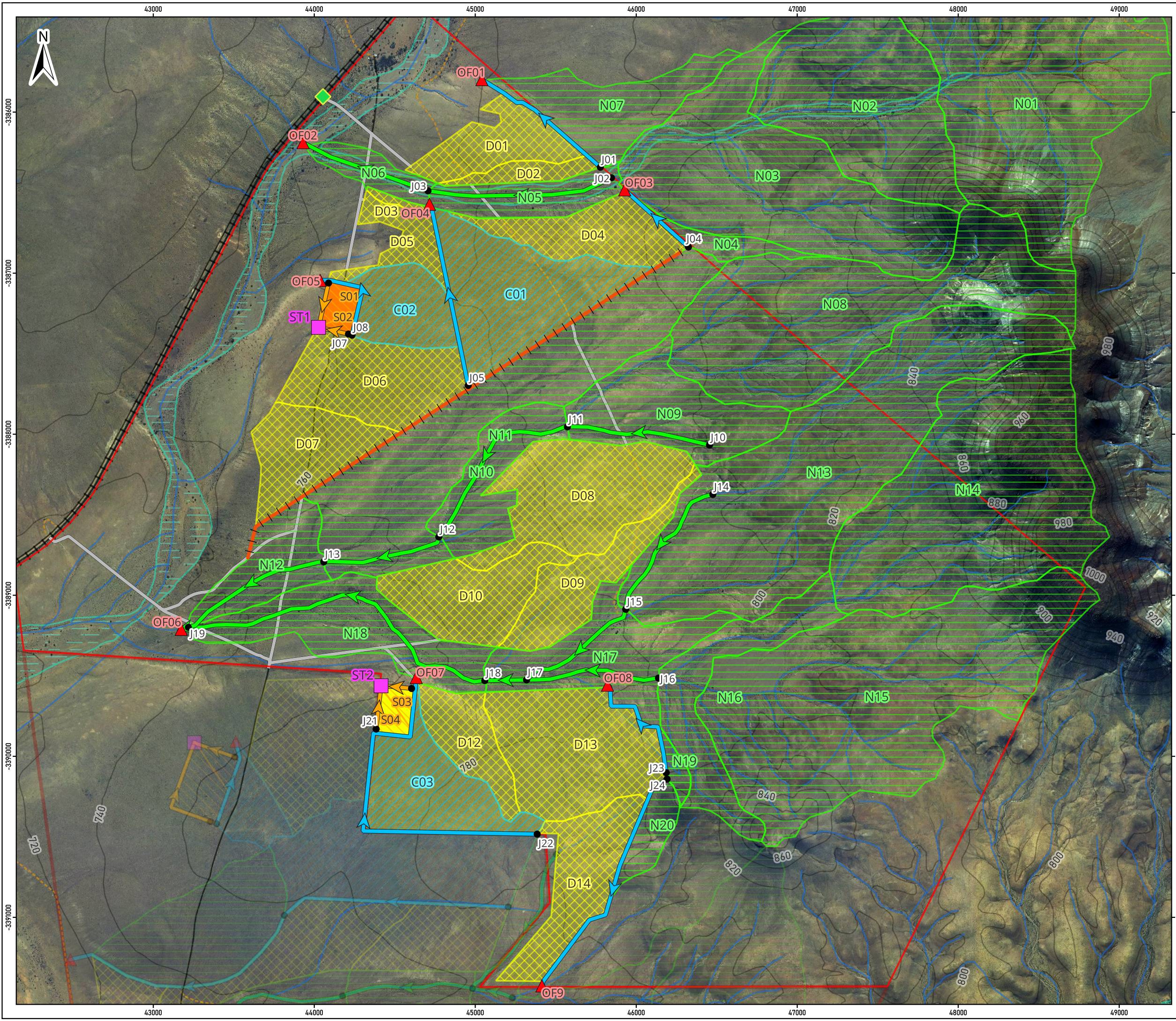

Legend

- Lesaka 1
- Lesaka 2
- ◆ Access Point
- Access Roads
- Substation and BESS
- Temporary Laydown and Construction Area
- Buidable Area
- Railway (50K Topo)
- Non-Perennial River (50K Topo)
- Dry Water Course (50K Topo)
- Footpath (50K Topo)
- Other Road (50K Topo)
- 20m Contours (50K Topo)
- Silt Trap
- ▲ Outfall
- Junction
- Diversion (Berm Only)
- ➔ Diversion (Berm and Channel)
- ➔ Natural Channel
- ➔ Silt Trap Diversion
- Subcatchment (Concentrated Runoff)
- Subcatchment (Distributed Runoff)
- Subcatchment (Natural)
- Subcatchment (Silt Management)

Figure 3-1

Conceptual Stormwater Management Plan

Hydrologic Consulting (Pty) Ltd

HYDRO LOGIC

+27 72 239 0974
 info@hydrologic.consulting
 www.hydrologic.consulting

0 200 400 600 800 1,000 m

Scale - 1:22,000
 @A3
 Coordinate Reference System: Hartebeesthoek94_Lo19_(E-N)
 Version 1
 20-Jul-2023

3.3.1 AVAILABLE INFORMATION

The following information was used to develop the SWMP:

- Climate Data: Particularly design rainfall depths;
- Elevation Data: The 30 DSM as outlined in Section 2.4 was used to define flow routes and sub-catchment divisions; and
- Catchment characteristics: Soil characteristics, land-cover and slopes were used to define catchment characteristics.

It should be noted that the results of the storm water modelling do not account for the influence climate change, changes in the terrain (that differs from the 30m DSM) and the potential localised storm water management that could be introduced (such as buffer strips). The addition of buffer strips and retention of the majority of the site's vegetation (between pylons) would likely reduce runoff rates to below current given the sparse vegetation on site at present

3.3.2 DIVERSIONS

Figure 3-2 represents a typical diversion channel consisting of a berm and channel component. The side slopes for all berms and channels have been kept constant at 1 vertical: 2 horizontal, while a minimum channel dimension of 0.5m channel depth and 1.0m channel base breadth has been used to simplify design. The exception to this are the natural river channels for which a side slope of 1 vertical: 50 horizontal was estimated.

The channel component has been sized using PCSWMM storm water modelling software to accommodate the 1:50 year RI event. A Manning's 'n' roughness coefficient of 0.025 (bare earth) was used in the sizing of the diversions channels. Figure 3-2 illustrates this drainage channel where:

- a = Channel Depth
- b = Channel Base Breadth

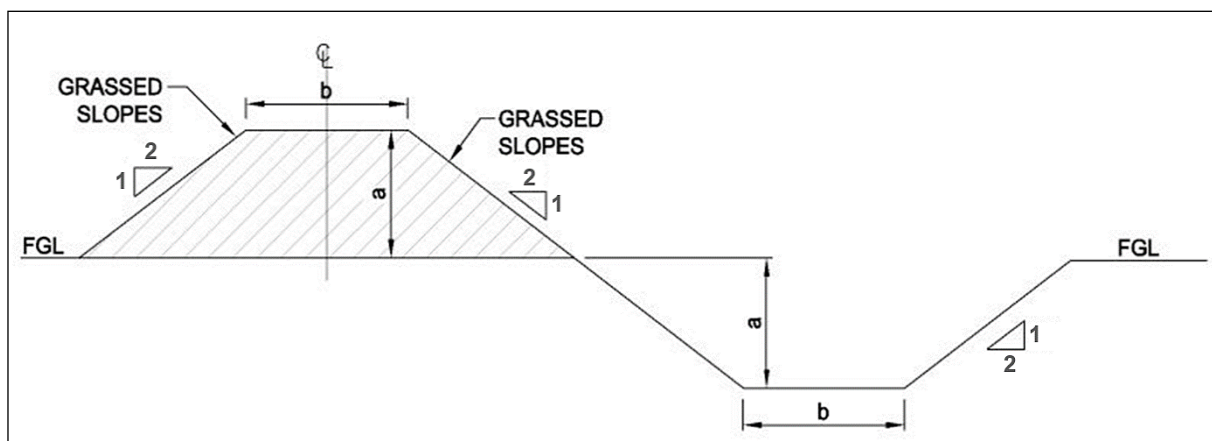

FIGURE 3-2: TYPICAL BERM AND CHANNEL FOR STORM WATER DIVERSION SYSTEM

Table 3-1 presents the dimensions of the clean area diversions, including the average longitudinal slope. The indicated dimensions and flows may differ from final, depending on the construction method, the location of diversions and the added detail included in the detailed design. The channel dimensions should consequently be reviewed during the detailed design phase.

TABLE 3-1: DIMENSIONS FOR DIVERSIONS AND NATURAL CHANNELS

Diversion	a (m)	b (m)	Average Longitudinal Slope (%)	Peak Flow (m ³ /s)	Comment
J01 to OF01	0.5	1.0	1.6	1.1	Upslope Diversion
J02 to J03	1.0	1.0	1.6	26.3	River - 1:50 side slope
J03 to OF02	1.0	1.0	1.3	27.3	River - 1:50 side slope
J04 to OF03	0.5	1.0	2.8	0.6	Upslope Diversion
J05 to OF04	0.75	1.0	0.3	1.9	Internal Diversion
J06 to ST1	0.75	1.0	1.8	0.7	Uses 1:10 year RI for sizing
J07 to ST1	0.5	1.0	2.6	0.3	Uses 1:10 year RI for sizing
J08 to OF05	0.75	1.0	0.3	1.1	Internal Diversion
J10 to J11	0.5	1.0	2.2	2.0	River - 1:50 side slope
J11 to J12	1.0	1.0	1.5	10.9	River - 1:50 side slope
J12 to J13	1.0	1.0	1.8	13.7	River - 1:50 side slope
J13 to OF06	1.0	1.0	1.7	14.4	River - 1:50 side slope
J14 to J15	1.0	1.0	1.6	5.0	River - 1:50 side slope
J15 to J17	1.0	1.0	1.9	5.6	River - 1:50 side slope
J16 to J17	1.0	1.0	1.6	22.1	River - 1:50 side slope
J17 to J18	1.0	1.0	1.5	26.6	River - 1:50 side slope
J18 to OF06	1.0	1.0	1.3	30.9	River - 1:50 side slope
J20 to ST2	0.5	1.0	1.6	0.4	Uses 1:10 year RI for sizing
J21 to ST2	0.5	1.0	2.2	0.5	Uses 1:10 year RI for sizing
J22 to OF07	0.5	1.0	1.3	1.3	Internal Diversion
J23 to OF08	0.5	1.0	2.4	0.4	Upslope Diversion
J24 to OF09	0.5	1.0	1.6	1.0	Upslope Diversion

The outfalls will direct concentrated channel flow to specific points of discharge and may require a reduction in velocity to limit potential erosivity of water (through the use of baffles, detention basins or similar).

3.4 EROSION CONTROL

Erosion control has partly been considered in this section with regards to storm water management and the routing of the runoff along trapezoidal channels (runoff that may otherwise be prone to the exacerbation or development of erosion if left unmanaged). Retention or rehabilitation of the natural land-cover and drainage of the site (post construction or decommissioning) will also serve to limit potential increases in erosion.

Additional principles are, however, included in the following (a combination of the various guidelines), and should be adhered to as far as possible:

- Clearing of vegetation and associated excavation areas should be kept to a minimum, particularly in areas where soils are unstable.
- The construction of any roads will create areas prone to erosion due to soils being exposed. Roads should therefore be constructed in a manner to rapidly stabilise soils, while roadside drainage should be included where necessary. For more information, please refer to the SANRAL (2013).
- Construction should preferably be scheduled to take place during the dry seasons when rainfall and associated erosion potential is at its least.
- Excavated soils should be stockpiled and separated into separate material types to enable replacement in the same order as excavated, during rehabilitation.
- Natural vegetation should be re-established to represent the previously undisturbed environment as closely as possible.
- A practical erosion control handbook should be developed, based on the principles developed in this report and given to the construction contractors to ensure the impact on receiving water resources is limited.
- Regular inspection of the site to assess erosion which may result from a loss in vegetation or cavitation from soil slumping, with intervention to prevent erosion where it is noticed.
- Watering to ensure wind erosion is limited during construction and to assist in the establishment of vegetation where possible.
- Maintenance and/or cleaning of all diversions and roadside drainage.
- The storm water management plan as outlined in this report will be an integral part of the control of possible erosion.

Management of erosion potential through regular inspection and maintenance is also of greater importance given the possible absence of gravel strips beneath panels (such that rainfall erosivity may be a problem).

3.4.1 SILT FENCES

Silt fences may be suitable in the control of potential erosion from areas disturbed during construction or decommissioning, particularly the concentrated areas of disturbance such as the O&M Building, substation and laydown area.

The United States Environmental Protection Agency (EPA) provides a detailed guide on the installation and maintenance of silt fences and the reader is referred to the following online document³. As defined by the EPA

³ <https://www3.epa.gov/npdes/pubs/siltfences.pdf>.

guide, a silt fence “is a temporary sediment barrier made of porous fabric. It’s held up by wooden or metal posts driven into the ground, so it’s inexpensive and relatively easy to remove. The fabric ponds sediment-laden storm water runoff, causing sediment to be retained by the settling processes”. A silt fence is possibly a cost-effective approach to erosion control management and suits the temporary nature of the construction phase of the project. The EPA guide can be consulted as to recommended design standards in this regard. Figure 4-3 illustrates a typical silt fence.

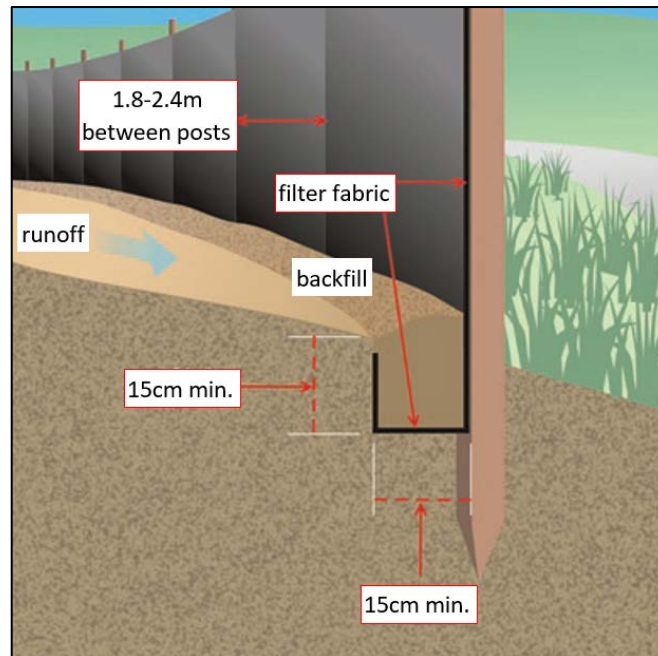

FIGURE 3-3: TYPICAL SILT FENCE (AFTER ENVIRONMENT PROTECTION AGENCY⁴)

3.4.2 SILT TRAPS

Silt traps have been proposed for the management of potential erosion at the substation/BESS and temporary laydown area/construction camp where the addition of hardstanding is likely to be greater and where disturbance of the current landscape is potentially more significant than for the greater PV array. These two areas have been conceptually managed using diversions that route internal runoff to a silt trap. Final design may adopt an alternate approach including the use of silt fences to enable rehabilitation of disturbed areas.

Guidance on the appropriate design of silt traps differs. A paper presented by Ferreria and Waywood at the 2009 International Mine Water Conference (Ferreria and Waywood, 2009), references the standards used by the Province of British Columbia (1996). These standards are as follows:

- Design flow for removal of suspended solids in silt traps should correspond to the 10-year, 24-hour storm flow.
- Easy removal of sediment at regular intervals
- Preferred shape of silt traps is generally rectangular with ratio of length to width of about 5 to 1.
- Unless there are mitigating factors, the pond should be sized to provide not less than a 20-hour detention time for a 1:10 year storm flow.

⁴ Illustration of a silt fence installation detail, from U.S. EPA publication, "Developing Your Stormwater Pollution Prevention Plan: A Guide for Construction Sites." Document No. EPA-833-R-060-04.

Silt management was consequently based upon the 1:10 year RI, 24-hour rainfall event.

Table 1 presents the simulated 1:10 year runoff volume for the silt trap of relevance. Design of silt traps has not been considered with volumes intended to inform design in the event silt traps are adopted.

TABLE 3-2: SILT TRAP INFLOW VOLUME (1:10 RI, 24-HOUR EVENT)

Silt Trap	Inflow Volume (m ³)
ST1	2,650
ST2	2,650

4 HYDROLOGICAL IMPACT ASSESSMENT

An impact is essentially any change (positive or negative) to a resource or receptor brought about by the presence of the project component or by the execution of a project related activity. Impacts include changes in the physical-chemical, biological, cultural and/or socio-economic environmental system that can be attributed to human activities.

This section evaluates the potential impact of the proposed development on adjacent watercourses. Watercourse is a term used in the National Water Act (Act No. 36 of 1998) (NWA) that includes various water resources, such as different types of wetlands (both natural and artificial), rivers, riparian habitat, dams and drainage lines (e.g. natural channels in which water flows regularly or intermittently).

Expected watercourse impacts associated with the proposed development are assessed in detail for the construction and operational phases of the project, using the approach provided in the Impact Assessment Methodology (Section 4.1 below), and includes the provision of recommended mitigation measures.

4.1 HYDROLOGICAL IMPACT ASSESSMENT METHODOLOGY

In order to be compliant with statutory requirements, a hydrological impact assessment was undertaken as per Regulation 31(2) (l) of the National Environmental Management Act (Act 107 of 1998) (NEMA). Regulation 31 (2) (l) states "(2) An environmental impact assessment report must contain all information that is necessary for the competent authority to consider the application and to reach a decision ...", and must comprise (l) an assessment of each identified potentially significant impact, including:

- Cumulative impacts;
- The nature of the impact;
- The extent and duration of the impact;
- The probability of the impact occurring;
- The degree to which the impact can be reversed;
- The degree to which the impact may cause irreplaceable loss of resources; and
- The degree to which the impact can be mitigated.

Assessment of predicted significance of impacts for a proposed development is by its nature, inherently uncertain. To deal with such uncertainty in a comparable manner, standardized and internationally recognized methodology have been developed. The potential impacts of the project have been evaluated using a recognised risk assessment methodology developed to ensure communication of the potential consequences or impacts of activities on the hydrological (surface water) environment as set out in NEMA.

Based on the above, the significance of potential impacts was determined through a synthesis of impact characteristics which include context and intensity of an impact. Context refers to the geographical scale (i.e. site, local, national or global), whereas intensity is defined by the severity of the impact e.g. the magnitude of deviation from background conditions, the size of the area affected, the duration of the impact and the overall probability of occurrence. Significance is calculated as shown in Table 4-1.

Significance is an indication of the importance of the impact in terms of both physical extent and time scale, and therefore indicates the level of mitigation required. The total number of points scored for each impact indicates the level of significance of the impact.

4.1.1 RATING SCALES APPLIED DURING THE IMPACT ASSESSMENT

In order to determine the significance of each identified potential impact, a numerical value has been linked to the respective factor (EXTENT; PROBABILITY; REVERSIBILITY; IRREPLACEABLE LOSS OF RESOURCES; DURATION; and INTENSITY/MAGNITUDE). Table 4-1 provides the rating assessment scales used in this study.

TABLE 4-1: RATING ASSESSMENT CLASSIFICATION

EXTENT (E)		
This is defined as the area over which the impact will be expressed. Typically, the severity and significance of an impact has different scales and as such bracketing ranges are often required. This is often useful during the detailed assessment of a project in terms of further defining the determined.		
Rating	Extent aspect	Scale
1	Site	The impact will only affect the site
2	Local/district	Will affect the local area or district
3	Province/Region	Will affect the entire province or region
4	International and National	Will affect the entire country
PROBABILITY (P)		
This describes the chance of occurrence of an impact		
Rating	Probability aspect	% Chance of occurring
1	Unlikely	The chance of the impact occurring is extremely low (Less than a 25% chance of occurrence).
2	Possible	The impact may occur (Between a 25% to 50% chance of occurrence).
3	Probable	The impact will likely occur (Between a 50% to 75% chance of occurrence).
4	Definite	Impact will certainly occur (Greater than a 75% chance of occurrence).
REVERSIBILITY (R)		
This describes the degree to which an impact on an environmental parameter can be successfully reversed upon completion of the proposed activity.		
Rating	Reversibility aspect	Degree
1	Completely reversible	The impact is reversible with implementation of minor mitigation measures
2	Partly reversible	The impact is partly reversible but more intense mitigation measures are required.
3	Barely reversible	The impact is unlikely to be reversed even with intense mitigation measures.
4	Irreversible	The impact is irreversible and no mitigation measures exist.
IRREPLACEABLE LOSS OF RESOURCES (L)		
This describes the degree to which resources will be irreplaceably lost as a result of a proposed activity.		
Rating	Loss of Resources aspect	Degree
1	No loss of resource.	The impact will not result in the loss of any resources.
2	Marginal loss of resource	The impact will result in marginal loss of resources.
3	Significant loss of resources	The impact will result in significant loss of resources.
4	Complete loss of resources	The impact is result in a complete loss of all resources.

DURATION (D)

This describes the duration of the impacts on the environmental parameter. Duration indicates the lifetime of the impact as a result of the proposed activity.

Rating	Duration aspect	Timeframe
1	Short term	The impact and its effects will either disappear with mitigation or will be mitigated through natural process in a span shorter than the construction phase (0 – 1 years), or the impact and its effects will last for the period of a relatively short construction period and a limited recovery time after construction, thereafter it will be entirely negated (0 – 2 years).
2	Medium term	The impact and its effects will continue or last for some time after the construction phase but will be mitigated by direct human action or by natural processes thereafter (2 – 10 years).
3	Long term	The impact and its effects will continue or last for the entire operational life of the development, but will be mitigated by direct human action or by natural processes thereafter (10 – 50 years).
4	Permanent	The only class of impact that will be non-transitory. Mitigation either by man or natural process will not occur in such a way or such a time span that the impact can be considered transient (Indefinite).

INTENSITY / MAGNITUDE (I / M)

Describes the severity of an impact (i.e. whether the impact has the ability to alter the functionality or quality of a system permanently or temporarily).

Rating	Intensity/Magnitude aspect	Intensity/Magnitude description
1	Low	Impact affects the quality, use and integrity of the system/component in a way that is barely perceptible.
2	Medium	Impact alters the quality, use and integrity of the system/component but system/ component still continues to function in a moderately modified way and maintains general integrity (some impact on integrity).
3	High	Impact affects the continued viability of the system/component and the quality, use, integrity and functionality of the system or component is severely impaired and may temporarily cease. High costs of rehabilitation and remediation.
4	Very High	Impact affects the continued viability of the system/component and the quality, use, integrity and functionality of the system or component permanently ceases and is irreversibly impaired (system collapse). Rehabilitation and remediation often impossible. If possible rehabilitation and remediation often unfeasible due to extremely high costs of rehabilitation and remediation.

4.1.2 METHODOLOGY USED IN DETERMINING THE SIGNIFICANCE OF IMPACTS

A quantitative approach was taken in determining environmental significance since this enables a cross disciplinary assessment of impacts and a consistent interpretation of impact significance.

Based on the information contained in the above rating assessment classification (Table 4-1), the potential impacts are assigned a significance rating (S). Significance is determined through a synthesis of impact characteristics. Significance is an indication of the importance of the impact in terms of both physical extent and time scale, and therefore indicates the level of mitigation required. This describes the significance of the impact on the environmental parameter. The calculation of the significance of an impact uses the following formula:

Significance = Extent (E) + Probability (P) + Reversibility (R) + Irreplaceable Loss (L) + Duration (D) x Intensity/Magnitude (I / M).

The summation of the different criteria will produce a non-weighted value. By multiplying this value with the magnitude/intensity, the resultant value acquires a weighted characteristic which can be measured and assigned a significance rating.

The significance of any identified potential impact is rated as either very high, high, medium, and low, as illustrated in Table 4-2.

TABLE 4-2: SIGNIFICANCE RATINGS

POINTS	IMPACT SIGNIFICANCE RATING	DESCRIPTION
5 to 23	Negative Low impact	The anticipated impact will have negligible negative effects and will require little to no mitigation.
5 to 23	Positive Low impact	The anticipated impact will have minor positive effects.
24 to 42	Negative Medium impact	The anticipated impact will have moderate negative effects and will require moderate mitigation measures.
24 to 42	Positive Medium impact	The anticipated impact will have moderate positive effects.
43 to 61	Negative High impact	The anticipated impact will have significant effects and will require significant mitigation measures to achieve an acceptable level of impact.
43 to 61	Positive High impact	The anticipated impact will have significant positive effects.
62 to 80	Negative Very high impact	The anticipated impact will have highly significant effects and are unlikely to be able to be mitigated adequately. These impacts could be considered "fatal flaws".
62 to 80	Positive Very high impact	The anticipated impact will have highly significant positive effects.

In order to reduce the degree to which the identified potential impacts may affect catchment hydrology, a series of mitigation measures relating to the identified potential impacts have been proposed. These mitigation measures are presented in Section 4.3.

4.1.3 SOURCE – PATHWAY – RECEPTOR MODEL

This assessment was carried out to determine the impacts on surface water and groundwater. The potential impacts were assessed for both the construction phase and the operational phase. The methodology for assessing and quantifying the significance of these impacts is detailed in this present Section 4.1.

The impacts were assessed based on the indicators that are identified in the baseline study within Section 2.

The *Source – Pathway – Receptor* model was used for the identification and assessment of potential hydrological impacts. The three different items of this model are detailed below in Section 4.1.3.

4.1.3.1 SOURCES

The Source is the proposed development as detailed in Section 1. The proposed Lesaka 1 Solar Energy development is located near Loeriesfontein in the Northern Cape Province of South Africa. The source differs during construction and operational stages.

Construction Phase

The construction phase is the more important stage in relation to impacts and the main activities in general are as follows:

- Clearing vegetation on site.
- Construction of access roads.
- Storage and erection of temporary structures to facilitate construction phase.
- Establishment of temporary site camp and laydown facilities
- Stockpiling of materials
- Excavations based on construction designs.
- Drainage during construction
- Drainage diversion channels and berms
- Hydrocarbons from machinery
- Cement based products suspended in water
- Rehabilitation and re-vegetation
- Flooding of site partly or fully

Operational Phase

The main activities during the operational stage that could cause impacts are as follows:

- Drainage from paved roads or hardened gravel areas that have access to vehicles
- Drainage from other paved / gravel areas
- Introduction of large-scale PV Solar panels with their associated base infrastructure / pylons
- Other hardstanding areas in the form of a substation/BESS
- Flooding of site partly or fully

4.1.3.2 PATHWAYS

The pathways are surface, subsurface and through conduits in bedrock. The surface pathways are drains, natural flow paths and overland sheet flow. The subsurface pathways are vertical and horizontal. The vertical pathways are determined from topsoil and subsoil permeability and groundwater vulnerability.

Soils on and surrounding the site are expected to have moderately low to moderately high runoff potential (SCS soil group B and C). Combined with the flat terrain and low rainfall of the region, runoff is only expected to occur during storms. The dominant occurrence of sparse vegetation in a desert climate means that areas of poor vegetation coverage are possible (i.e. bare areas). These areas would increase the potential for runoff due to the absence of vegetation that may otherwise slow down runoff (and promote infiltration).

The site is drained via a network of non-perennial water courses, expected to flow for short durations following significant rainfall events into the Klein-Rooiberg River, which ultimately contribute to the Berg-Olifants Water Management Area in South Africa.

4.1.3.3 RECEPTORS

The relevant receptors are as follows:

- Klein-Rooiberg River
- Network of non-perennial streams
- The site lies within quaternary catchment E31C, which ultimately forms part of the Berg-Olifants Water Management Area in South Africa.

4.2 ASSESSMENT OF THE IMPACTS FROM THE PROPOSED DEVELOPMENT

This assessment is carried out as detailed in the Methodology, Section 4.1.3 for the Sources noted in Section 4.1.3.1. The sources were identified for the construction phase and operational phase. The same categorisation is continued in this Section. The proposed development is considered in its entirety rather than individual parts.

4.2.1 CONSTRUCTION PHASE

Clearing vegetation on site

Clearing of vegetation on site will result in change of biodiversity, degradation of the topsoil due to erosion and presence of suspended solids in surface runoff. Biodiversity is outside the scope of the present report and erosion could happen only during the period of the land is exposed after the vegetation is removed and construction work commences. A worst-case scenario is the site is left for a long duration after the vegetation is removed. The receptors are the surface water channels, the Klein-Rooiberg River and its non-perennial streams.

Construction of access roads

This will also cause suspended solids in surface runoff. The receptors are the surface water channels, the Klein-Rooiberg River and its non-perennial streams. Constructed access roads will be in close proximity to these non-perennial drainage lines.

Storage and erection of temporary structures to facilitate construction phase

Hydrocarbons and cement are considered under a separate heading and are not considered here. This includes stockpiles, laydown, material storage areas, or temporary structures erected on site. The effects may be on diminished water quality or impeded water flow. The receptors are the surface water channels; the Klein-Rooiberg River and its non-perennial streams; and probably groundwater, depending on the material on storage.

General waste from construction personnel

This refers to the waste generated during the construction phase. The receptors are surface water channels, the Klein-Rooiberg River and its non-perennial streams; and probably groundwater.

Excavations based on construction designs

Large excavations are not envisaged during the construction of the proposed development based on the site layout. There aren't structures that need deep excavations. The main receptors are surface water channels; the Klein-Rooiberg River and its non-perennial streams. Groundwater could be a receptor with low probability. The effects are similar to those noted in headings above: degradation of the topsoil due to erosion and the presence of suspended solids in surface runoff.

Drainage during construction

The drainage considered here refers to those provided during the construction stages: diversion of water flow away from construction areas; construction of storm water management infrastructure channels; and road crossings with culverts over existing drainage lines. The main receptors are surface water channels, the Klein-Rooiberg River and its non-perennial streams. The main effect is erosion based on velocities and quantity.

Hydrocarbons from machinery and vehicles

These constitute storage, leaks and accidental spills of fuels and lubricants. They are all petroleum-based products. The main receptors are surface water channels, the Klein-Rooiberg River, its non-perennial streams and groundwater.

Cement based products suspended in water

Cement will be used in concreting throughout the site and any wash aways and other spillage from use and transport. The main receptors are surface water channel, the Klein-Rooiberg River, its non-perennial streams and groundwater.

Landscaping / Grassing

The effects from landscaping are similar to the effects from the headings above, in that it will disturb topsoil layers and increase suspended solids in surface runoff. An increase in lawn areas as opposed to shrubs will reduce the 'surface roughness' provided by natural vegetation, thus encouraging sheet flow and increased runoff velocities. The receptors are the surface water channels, the Klein-Rooiberg River and its non-perennial streams.

Flooding of site partly or fully

The slopes on site are mild, with slopes typically below 10%. This terrain data, together with the aridity of this region, indicate that the risk of flooding of the site from the adjacent areas is extremely low.

4.2.2 OPERATIONAL PHASE

Drainage from paved areas that have access to vehicles

Drainage of surface water runoff from paved internal roads, gravel roads, and other hardened surfaces. The increase of surface water runoff volumes and the time of concentration (travel time) could increase the flood peaks in the surface water channels, the Klein-Rooiberg River, and its non-perennial streams. The surface runoff could have dissolved hydrocarbons and could affect groundwater.

An increase in the kinetic energy and splash erosion potential resulting from the 'hard' surfaces of PV panels and their base infrastructure

The kinetic energy of runoff falling from panels is a possible cause of erosion (at the base of panels). It is recommended that the grass beneath the panels be well maintained or that a buffer strip be placed after the most downgradient row of panels. Gravel strips are consequently only recommended below panels where grass cannot be cultivated (to limit possible increased erosivity of runoff falling from panels). This could increase erosion and the sediment loads reaching the surface water channels, the Klein-Rooiberg River, and its non-perennial streams

Flooding of the development partly or fully

The slopes are fairly steep and the proposed development areas are elevated above the main drainage lines (see Figure 2-3). Therefore, the risk of flooding of the site from the Klein-Rooiberg River is extremely low.

4.2.3 DECOMMISSIONING PHASE

Clearing or disturbance to vegetation on site

Clearing of re-vegetated growth that established over the project's life-cycle will result in degradation of the topsoil due to erosion and presence of suspended solids in surface runoff. A worst-case scenario is the site is left for a long duration after the vegetation is disturbed. The receptors are the surface water channels, the Klein-Rooiberg River and its non-perennial streams.

Storage, stockpiling and removal of existing structures to facilitate decommissioning phase

This includes stockpiles, material storage areas, or waste removed from site. The effects may be on diminished water quality or impeded water flow. The receptors are the surface water channels; the Klein-Rooiberg River and its non-perennial streams; and probably groundwater, depending on the material on storage.

Hydrocarbons from machinery and vehicles

These constitute storage, leaks and accidental spills of fuels and lubricants. They are all petroleum-based products. The main receptors are surface water channels, the Klein-Rooiberg River, its non-perennial streams and groundwater.

4.3 HYDROLOGICAL IMPACT SIGNIFICANCE AND MITIGATION MEASURES

This assessment is carried out as detailed in the Methodology, Section 4.1.1 and 4.1.2, where the significance of hydrological impacts are quantified as per the ratings criteria in Tables 4-1 and 4-2.

The following potential hydrological impacts were identified to be associated with the proposed development and are included in this impact assessment:

- Changes in catchment water resources,
- Changes in catchment water quality, and
- Changes in flood hydrology.

Table 4-3 presents the results of the significance ratings attributed to each of the identified potential impacts for the construction, operational, and decommissioning phases.

TABLE 4-3: SIGNIFICANCE RATINGS OF POTENTIAL IMPACTS

ENVIRONMENTAL PARAMETER ISSUE / IMPACT / EFFECT	ENVIRONMENTAL SIGNIFICANCE BEFORE MITIGATION									COMMENTS / RECOMMENDED MITIGATION MEASURES	ENVIRONMENTAL SIGNIFICANCE AFTER MITIGATION								
	E	P	R	L	D	I/ M	TOTAL	STATUS (+ OR -)	S		E	P	R	L	D	I/ M	TOTAL	STATUS (+ OR -)	S
Construction Phase																			
Changes in Catchment Water Resources due to:																			
Impeding or diverting the flow of water in a watercourse	1	4	2	2	3	2	24	-	Medium	Storm water management infrastructure development such as diversion berms channels and silt management through silt traps and silt fences	1	2	1	2	1	1	7	-	Low
Altering the characteristics of catchment areas	1	1	2	2	1	1	7	-	Low	The proposed development is associated with the conversion of natural areas to developed areas. This is likely to alter the hydrological characteristics of the immediate areas associated with development. This impact is largely limited to the project site and is therefore associated with a low significance level. Natural vegetation should be re-established to represent the previously undisturbed environment as closely as possible.	1	1	1	1	1	1	5	-	Low

Reduction in Catchment Water Quality due to:

<p>Erosion from disturbed open ground areas during construction (Disturbed and unconsolidated soil and stockpile)</p>	2	4	2	2	2	2	24	-	Medium	<p>Any rainfall falling onto open ground during the construction phase may result in erosion and sediment being transported into the nearby streams.</p> <p>Clearing of vegetation and associated excavation areas should be kept to a minimum, particularly in areas where soils are unstable.</p> <p>Mitigation measures include the implantation of flow control measures upstream of a construction site (through berms) and limiting sediment from being eroded from a construction site (through silt fences)</p>	1	2	1	1	1	1	6	-	Low
<p>Contamination of the watercourses and down slope stream areas by spills of cement and other construction-related hazardous chemicals</p>	1	2	1	1	1	2	12	-	Low	<p>The storage/handling of fuel, lubricants and chemicals will require special attention due to their hazardous nature as is the case with the laydown areas. These areas are required to be managed on impermeable floors with appropriate bunding, sumps and roofing.</p>	1	1	1	1	1	1	5	-	Low
<p>Contamination of the watercourses and down slope stream areas by spills of hydrocarbons from construction vehicles and workshop areas</p>	2	3	2	2	2	2	22	-	Low	<p>There is an inherent risk of spillage from machinery and hydrocarbon stores, particularly during the construction phase.</p>	1	1	1	1	1	1	5	-	Low
<p>Disturbance to vegetation cover thus reducing the site's natural ability to biofilter the surface runoff and groundwater reaching downstream drainage lines</p>	1	4	2	2	2	2	22	-	Low	<p>Clearing of vegetation on site will result in change of biodiversity, degradation of the topsoil due to erosion and presence of suspended solids in surface runoff. Retention or rehabilitation of the natural land-cover and drainage of the site (post construction or decommissioning) will also serve to limit potential increases in erosion.</p>	1	3	2	2	1	1	9	-	Low

Changes in Flood Hydrology due to:																			
An increase in impervious areas	2	4	2	2	2	2	24	-	Medium	Due to the conversion of permeable surfaces to impermeable surfaces (i.e. internal roads, construction camps, laydown areas, storage areas, and PV panel infrastructure), the peak discharge rate of local streams will be increased. The impact of this is associated with a medium significance rating.	1	4	2	1	2	2	20	-	Low
Impeding flow	1	4	2	1	3	2	22	-	Low	Stream diversions are proposed near the buildable area, the construction camp/laydown area, and the substation area, which is likely to impede the natural flow of water across the site.	1	3	2	1	2	2	18	-	Low
Operational Phase																			
Changes in Catchment Water Resources due to:																			
Impeding or diverting the flow of water in a watercourse	2	3	2	2	3	1	12	-	Low	Mitigation measures required through implementation of Storm water management plan, and proposed diversion berms / channels. Changes in catchment water resources and ecosystem functionality are expected to be minimal as a result of the proposed development.	1	2	1	1	3	1	8	-	Low
Altering the characteristics of local catchment areas	2	2	2	2	3	1	11	-	Low	Impacts on the local hydrology are unavoidable. These impacts are, however, limited to the local hydrology and are therefore associated with a low significance rating.	1	1	2	1	2	1	7	-	Low

<p>Natural vegetation disturbance/loss resulting in the emergence of invasive alien vegetation, placing further pressure on water resources</p>	2	1	1	2	2	2	16	-	Low	<p>Rehabilitation design should initially include those pioneer species for fast coverage and establishment. With the aim of later include a mix of locally indigenous shrubbery for biodiversity re-establishment and reinstatement to baseline site conditions. This will minimize the opportunity for invasives to establish on disturbed soils.</p>	1	1	1	2	2	1	7	-	Low
<p>Reduction in Catchment Water Quality due to:</p>																			
<p>Contamination of the watercourses and down slope stream areas by spills from chemicals used to clean or maintain the facility's assets</p>	1	1	1	1	2	2	12	-	Low	<p>The storage/handling of fuel, lubricants and chemicals will require special attention due to their hazardous nature as is the case with the laydown areas. These areas are required to be managed on impermeable floors with appropriate bunding, sumps and roofing.</p>	1	1	1	1	2	1	6	-	Low
<p>Contamination of the watercourses and down slope stream areas by spills of hydrocarbons from maintenance or delivery vehicles</p>	1	1	1	1	2	2	12	-	Low	<p>The movement of vehicles over the site will also introduce possible hydrocarbons. These constitute storage, leaks and accidental spills of fuels and lubricants.</p>	1	1	1	1	2	1	6	-	Low
<p>Disturbance to the 'surface roughness' of baseline vegetation cover, thus reducing the site's natural ability to biofilter the runoff and groundwater reaching downstream drainage lines</p>	1	3	2	2	2	2	20	-	Low	<p>Timeous and effective post-construction rehabilitation / re-vegetation adds protection to those disturbed topsoil layers and reduces the suspended solids in surface runoff. Rehabilitation design should aim to increase the 'surface roughness' provided by natural vegetation, thus reducing sheet flow and runoff velocities.</p>	1	2	1	1	2	2	14	-	Low
<p>Changes in Flood Hydrology due to:</p>																			

<p>An increase in impervious areas, in the form of internal access roads and service infrastructure</p>	1	2	2	1	3	1	9	-	Low	<p>Solar panels do not have a significant effect on existing runoff rates, runoff volumes or time to peak of runoff. The presence of gravel or bare ground under the panels could, however, significantly increase the amount of runoff generated.</p>	1	2	1	1	2	1	7	-	Low
<p>An increase in the kinetic energy and splash erosion potential resulting from the mass introduction of 'hard' surfaces, in the form of PV panels and their base infrastructure</p>	1	3	3	1	3	1	11	-	Low	<p>The kinetic energy of runoff falling from panels is a possible cause of erosion (at the base of panels). It is recommended that the grass beneath the panels be well maintained or that a buffer strip be placed after the most downgradient row of panels. Gravel strips are consequently only recommended below panels where grass cannot be cultivated (to limit possible increased erosivity of runoff falling from panels).</p>	1	3	3	1	3	1	11	-	Low
<p>Impeding / diverting natural flows</p>	2	3	2	2	2	2	22	-	Low	<p>In order to mitigate against discharge rates impacting the proposed development areas, it is recommended that the proposed storm water management plan is implemented. This will ensure the attenuation of storm water runoff. It is also recommended that berms, channels, and sediment traps associated with the drainage lines are designed appropriately (in accordance with the best practice guidelines).</p>	1	3	2	1	2	2	18	-	Low
<p>Decommissioning Phase</p>																			
<p>Reduction in Catchment Water Quality due to:</p>																			
<p>Contamination of the watercourses and down slope stream areas by spills of hydrocarbons from an increase in decommissioning machinery or loading / transport vehicles</p>	2	3	2	2	2	2	22	-	Low	<p>There is an inherent risk of spillage from machinery and hydrocarbon stores, particularly when there is an increase in vehicular traffic during the decommissioning phase.</p>	1	1	1	1	1	1	5	-	Low

Disturbance to the site's established vegetation cover, resulting in bare soil exposure, and thus increasing the risk of erosion and sediment reaching downstream drainage lines	1	4	2	2	2	2	22	-	Low	Clearing of vegetation on site will result in change of biodiversity, degradation of the topsoil due to erosion and presence of suspended solids in surface runoff. Retention or rehabilitation of the natural land-cover and drainage of the site (post-decommissioning) will serve to limit potential increases in erosion.	1	2	1	1	2	2	14	-	Low
Cumulative																			
Reduction in Catchment Water Quality due to:																			
A series (or high frequency) of localised hydrocarbon or hazardous material spills, leads to a 'larger-scale' impact on surrounding freshwater ecological systems, which may become irreversible.	2	1	2	3	3	3	33	-	Medium	Although the probability of this occurring on a frequent basis is low, the cumulative impacts of these events would be severely negative for downstream systems over the long term.	1	1	2	2	2	2	16	-	Low
Changes in Flood Hydrology due to:																			
This photovoltaic project, together with any other proposed and existing projects and activities in the area would have a cumulative impact on the surface runoff regime, due to a 'broad-scale' increase in impervious areas, in the form of internal access roads and service infrastructure	2	2	2	1	2	2	18	-	Low	With respect to soils, permeability, and from a surface run-off perspective, multiple projects would result in a large disturbance footprint, collectively causing a series of cumulative impacts.	2	1	1	1	2	2	14	-	Low

As presented in Table 4-3, a number of the identified potential impacts are associated with a medium significance level. The following Sections 4.3.1 to 4.3.3 provide further details regarding the significance of the potential impacts as well as mitigation measures that should be implemented to reduce these potential negative impacts.

4.3.1 CHANGES IN WATER RESOURCES

A hydrological characterisation of the local catchment area was undertaken using quaternary catchment-based information. This consisted of the MAE, MAP and Mean Annual Runoff (MAR).

Indirect impacts of the proposed development on catchment water resources may be realised through altering the rainfall and runoff characteristics of the upstream catchment. More specifically, changing currently pervious stands of land (i.e. natural ground with vegetation cover) to hardened impervious stands of land.

The anticipated impact of the development will likely be an increase in the discharge rates from the local catchment areas to the Klein-Rooiberg River (i.e. and increase in stormflows), and potentially a decrease in groundwater contributions to the river (i.e. reduction in baseflows). This is as a result of an increase in hardened surfaces associated with infrastructure and roads within the proposed development. Hardened surfaces result in increased rainfall to runoff conversion rates and increased flow velocities. However, the hardened surfaces also result in a reduction in infiltration and therefore baseflows. In order to mitigate against these identified impacts, it is recommended that the proposed storm water management plan is implemented.

4.3.2 REDUCTION IN WATER QUALITY

A reduction in catchment water quality has implication to both the downstream ecology and downstream water users. Potential sources and types of surface water contamination include the following:

- Sediment entering the downstream environment during construction.
- General waste (including litter) entering the downstream environment.
- Heavy metals from cement mixing on site, building waste and rubble entering the downstream environment during construction.
- Hydrocarbon spillages from leaking plant and equipment entering the downstream environment.

In order to mitigate against these identified potential sources of contaminated runoff, the following is proposed:

- All soil excavated during the construction process should be deposited outside of the drainage lines. This will limit the amount of fine sediments transported downstream (negatively affecting ecosystems).
- Berms upslope and downslope of areas likely to be a source of sediment contamination should be implemented. Upslope berms will ensure limited surface flows through areas associated with sediment loss. Downslope berms will ensure that sediments eroded from areas associated with sediment loss will be trapped, therefore reducing the impact to the downstream receiving environment. It is recommended that the berms are constructed out of a non-erodible material.
- All storm water runoff from areas likely to be a source of sediment contamination should be directed to a sediment trap, where sediment will be deposited rather than entering into the receiving environment.
- All domestic waste should be regularly removed from the construction site on a regular basis and dumped in appropriate waste handling facilities.

- Berms or bunded areas should be implemented around the cement mixing area, as well as the building waste and rubble area to prevent storm water runoff to the downstream environment.
- Plant and equipment should be regularly checked (at least daily) for oil leaks and repaired timeously if required to prevent hydrocarbon contamination. During periods where the machinery is not in use, drip trays should be placed under the machinery to contain any spillages,
- Areas that may result in the contamination to groundwater should be sufficiently lined to meet with regulatory requirements, and
- Once the construction has been completed, rehabilitation of the affected areas should be undertaken. This should include planting indigenous pioneer vegetation to ensure that erosion from the construction site is minimised.
- Construction should be scheduled to take place during the dry seasons when rainfall and associated erosion potential is at its least.

It is envisaged that if the above-mentioned mitigation measures are implemented, the risk of negatively impacting upon the water resources and ecosystem functionality downstream of the project site will be largely reduced.

4.3.3 CHANGES IN FLOOD HYDROLOGY

As mentioned previously, due to an increase in impervious areas and changes in catchment landcover characteristics associated with the proposed development, there is a possibility that this will result in a slight increase in the peak discharge values from the catchment in which the development is located.

5 CONCLUSIONS AND RECOMMENDATIONS

Baseline Assessment

Baseline information including monthly rainfall, monthly evaporation, design event rainfall, soils, vegetation and land cover, as well as site topography and regional and local catchment hydrology were considered for the proposed Lesaka 1 Solar Energy Facility located near Loeriesfontein in the Northern Cape Province of South Africa. This baseline confirmed that potential evaporation greatly exceeds rainfall (2673mm versus 199mm respectively) and that design rainfall depths associated with extreme events are still reasonably significant at 54mm, 77mm, 87mm and 98mm for the 24-hour 1:10, 1:50, 1:100 and 1:200 year recurrence interval respectively.

The following terrain (elevation) datasets were used in this study, namely:

1. A 30m DSM global digital surface model (DSM); and
2. National Geospatial Institute (NGI) 20m contours.

Ground elevations on the site approximate 780mAMSL. Site slopes are mild, with slopes typically below 10%. The NGI's 20m contours provide a generalised understanding of the terrain of the site and its surroundings.

The site lies within quaternary catchment E31C. The NGI's 1:50,000 topographical map data as well as derived 30m DSM indicate that the site is drained via a network of non-perennial water courses, expected to flow for short durations following significant rainfall events into the Klein-Rooiberg River, which ultimately contribute to the Berg-Olifants Water Management Area in South Africa.

Soils on site are classified sands to loams and fall within hydrological soil group B (moderately low runoff potential) to the west of the site and hydrological soil group C (moderately high runoff potential) to the east of the site. The natural vegetation of the site is classified Hantam Karoo (succulent karoo vegetation). Land-cover of the site is mostly classified as 'barren land' with minor areas of 'shrubland' present with near negligible areas of 'forested land'. During the site visit it was confirmed that whilst vegetation is sparse, there is indeed the presence of shrubs and grasses across the site.

Storm Water Management Assessment

In general terms, the proposed solar project will alter the natural environmental state, thereby affecting the generation of storm water and the associated potential for erosion. Volumes of storm water generated over disturbed areas are generally expected to increase because of the reduction in natural vegetation or the addition of areas of hardstanding. The quality of the storm water generated is also expected to be affected by the removal of vegetation and excavation of soils (i.e. potential erosion will increase). The movement of vehicles over the site will also introduce possible hydrocarbons.

In considering the site, some hardstanding areas are proposed in the form of the Substation and Battery Energy Storage System (BESS), temporary laydown and construction area, and solar panel pylons (specifically their foundations). The solar panels themselves do not qualify as hardstanding since they do not limit infiltration beneath them (beyond the foundation and pylon to which they're fixed). Some compaction of soils on site is expected, particularly with regards to areas of travel, such as the internal access roads and laydown areas.

The development of the solar farm will likely consequently be associated with a limited change to the natural land-cover when the full site is considered, assuming disturbed land-cover (i.e. soils and vegetation) is rehabilitated.

The implication of this rehabilitation (of the areas between panel foundations), is that most of the site can retain a naturalised hydrological response where both the quantity and quality of storm water is similar to the natural baseline environment.

Nonetheless, a conceptual storm water management plan has been developed for the site aimed at ensuring the impact of water generated upstream or on site during extreme rainfall events can be better managed by routing storm water away from infrastructure thereby reducing any associated flood risk. The approach to sub-catchment delineation was based upon the position of the proposed infrastructure and the natural drainage. Areas downslope of proposed infrastructure were not considered since storm water generated from these locations would not influence the proposed infrastructure. Diversions have been sized (1:50 year, 24-hour RI event) and positioned to direct runoff generated within or upslope of the site, towards natural drainage lines. It is recommended that diversions incorporate soft engineering approaches with grassed swales being an option that would likely integrate well with the landscape. The natural land-cover and drainage of the site should be retained insofar as is possible (as a general guideline).

The assessment of sub-catchment requiring diversions made use of the 30m DSM. A 25ha minimum sub-catchment area was used as the area above which individual sub-catchments were identified as having concentrated runoff with the recommendation that storm water management be included – through the addition of a diversion. The majority of the site (to be developed) had sub-catchments with an area below 25ha and were identified as having distributed runoff without the need for formal storm water management. Furthermore, the area associated with the substation/BESS and temporary laydown area/construction camp was classified as requiring silt management given the more concentrated development expected over this area (and the associated increased disturbance).

Areas that are not to be developed within the site but that received runoff from the aforementioned catchments prior to routing this runoff past the developable area were included as natural sub-catchments. This enables the assessment of the combined rainfall-runoff response for the non-perennial rivers intersecting the site which may be of value with regards to the sizing of river crossings or with regards to anticipating the peak flows that might be generated for the 1:50 RI event. As this is a conceptual SWMP, this report does not present the definitive SWMP for the site, which may see value in additional storm water management infrastructure (eg drainage channels) to the site, particularly once the PV array layout within these developable areas is finalised.

It is recommended that the site is regularly inspected, with areas prone to erosion identified. Silt fences may be suitable for the control of erosion from areas disturbed or affected during construction, operation or decommissioning. A number of principles aimed at ensuring soil erosion is kept to a minimum have been presented in this report. It is important to note that the Lesaka 1 and Lesaka 2 projects are not hydrologically independent of each other and as such, the SWMPs should be viewed in this context.

Hydrological Impact Assessment

A hydrological impact assessment was undertaken to determine the significance of each identified potential impact according to impact probability, frequency, extent, duration, and intensity. Potential impacts considered in this assessment for the construction and operational phases were changes in catchment water resources, changes in catchment water quality, and changes in flood hydrology. The assessment further considered appropriate mitigation techniques which should be adopted in order to reduce impact significance. Potential significance for the considered impacts ranged from medium in the pre-mitigation scenarios to low in the post mitigation scenarios. It is

recommended that a surface water monitoring plan be developed for the proposed development. This should be developed prior to development to ensure any impacts on receiving water resources resulting from both the construction and subsequent operation of the proposed development. These monitoring points should be located both upstream and downstream of the proposed development site to ensure any impacts can be identified with appropriate responsive mitigation measures implemented.

Tables 5-1 to 5-3 below, provide a description of the key monitoring recommendations for the applicable mitigation measures identified for each phase of the project.

TABLE 5-1: KEY MONITORING RECOMMENDATIONS FOR THE CONSTRUCTION PHASE

Impact/Aspect	Mitigation/Management Actions	Responsibility	Methodology	Mitigation/Management Objectives and Outcomes	Frequency
Impeding or diverting the flow of water in a watercourse	Storm water management infrastructure development such as diversion berms channels and silt management through silt traps and silt fences	Engineer / Contractor / ECO	Ensure berms, channels and silt traps are built in accordance with design specs, and their integrity is maintained	Diversion of surface/stream flow away from construction footprints, site camps, and laydown/storage areas	Initial construction / Monthly / After major rainfall event
Erosion from disturbed open ground areas, unconsolidated soil and stockpiles	All exposed soil, including stockpiles, must be protected for the duration of the construction phase with a suitable geotextile (e.g., Geojute or hessian sheeting)	Contractor / ECO	Inspect stockpiles and exposed ground areas, particularly during wind or rainy conditions	To prevent excessive erosion, and sedimentation of the receiving freshwater environment.	Weekly / After major rainfall event
Contamination of the watercourses and down slope stream areas by spills of hydrocarbons from construction vehicles and workshop areas	Ensure adequate training of all machine operators, and conduct daily checks on vehicles/machinery. Breakdowns to be fixed off-site. Spill kits to be readily available. Ongoing sampling/monitoring of nearby water resources.	Contractor / ECO / Water Scientist	Do spot checks on vehicle checklists / operational compliance. Collect & analyse water quality parameters at specified monitoring points	Water monitoring points should be located both upstream and downstream of the proposed development site to ensure any impacts can be identified with appropriate responsive mitigation measures implemented.	Monthly / After major spill event
Disturbance to natural vegetation cover	All footprint areas must remain as small as possible and vegetation clearing to be limited to what is absolutely essential to ensure as much indigenous vegetation is retained. Adequate re-vegetation to those disturbed areas.	ECO	Monitoring of grass germination and soil amelioration. Ensure that no natural vegetation on site is disturbed unnecessarily.	To ensure adequate and fast surface coverage, to minimise erosion potential.	Weekly
An increase in impervious areas	All excavated areas must be compacted to natural soil compaction levels to prevent the formation of preferential surface flow paths and subsequent erosion. Conversely, areas compacted as a result of construction must be loosened to natural soil compaction levels.	ECO	Non-footprint areas to be assessed for adequate rehabilitation. Grass berms around solar infrastructure to be closely monitored.	To reduce the impact and erosive potential of water flowing off hardened surfaces.	Weekly

TABLE 5-2: KEY MONITORING RECOMMENDATIONS FOR THE OPERATIONAL PHASE

Impact/Aspect	Mitigation/Management Actions	Responsibility	Methodology	Mitigation/Management Objectives and Outcomes	Frequency
Natural vegetation disturbance/loss resulting in the emergence of invasive alien vegetation	Alien and invasive plant species identified must be removed and disposed of as per an Alien and Invasive Species Control Plan and the area must be revegetated with suitable indigenous vegetation;	ECO	Regular inspection of the area surrounding the surface infrastructure (proposed PV facility and grid connection infrastructure) should occur to monitor the establishment of vegetation, prevent the establishment of alien and invasive vegetation species, and their potential spread into the surrounding freshwater ecosystem;	Reintroduce indigenous vegetation during rehabilitation, to outcompete in emerging aliens. Ensure that invasive species do not become established on site and further impact freshwater systems.	Monthly
Contamination of the watercourses and down slope stream areas by spills from chemicals used to clean or maintain the facility's assets	Ensure adequate training of all cleaning staff. conduct daily checks on cleaning equipment. Spill kits to be readily available. Ongoing sampling/monitoring of nearby water resources	Contractor / ECO / Water Scientist	Do spot checks on cleaning equipment checklists / storage facilities. Collect & analyse water quality parameters at specified monitoring points	Water monitoring points should be located both upstream and downstream of the proposed development site to ensure any impacts can be identified with appropriate responsive mitigation measures implemented.	Monthly / After major spill event
An increase in impervious areas, in the form of internal access roads and service infrastructure	All footprint areas must remain as small as possible and vegetation clearing to be limited to what is absolutely essential to ensure as much indigenous vegetation is retained. Vegetated berms to be placed along the downslope of solar infrastructure, so slow the accelerated runoff from hardened surfaces.	ECO	Assess and document vegetation growth at the base of solar infrastructure. Record areas of erosion, subsidence, or soil loss. Ensure surface runoff is adequately channelled.	To reduce the rates of increased surface flow velocity, thus decreasing the risk of erosion and sediment reaching the natural water resources	Monthly

TABLE 5-3: KEY MONITORING RECOMMENDATIONS FOR THE DECOMMISSIONING PHASE

Impact/Aspect	Mitigation/Management Actions	Responsibility	Methodology	Mitigation/Management Objectives and Outcomes	Frequency
Contamination of the watercourses and down slope stream areas by spills of hydrocarbons from an increase in decommissioning machinery or loading / transport vehicles	Ensure adequate training of all machine operators, and conduct daily checks on vehicles/machinery. Breakdowns to be fixed off-site. Spill kits to be readily available. Ongoing sampling/monitoring of nearby water resources.	Contractor / ECO / Water Scientist	Do spot checks on vehicle checklists / operational compliance. Collect & analyse water quality parameters at specified monitoring points	Water monitoring points should be located both upstream and downstream of the proposed development site to ensure any impacts can be identified with appropriate responsive mitigation measures implemented.	Monthly / After major spill event
Disturbance to the site's established vegetation cover, resulting in bare soil exposure, and thus increasing the risk of erosion and sediment reaching downstream drainage lines	All excavated areas must be compacted to natural soil compaction levels to prevent the formation of preferential surface flow paths and subsequent erosion. Conversely, areas compacted as a result of construction activities must be loosened to natural soil compaction levels. Adequate re-vegetation to those disturbed areas.	ECO	Monitoring of grass germination and soil amelioration. Ensure that no natural vegetation on site is disturbed unnecessarily.	To ensure adequate and fast surface coverage, to minimise erosion potential.	Weekly

No fatal flaws were identified during the hydrological investigations for the proposed Lesaka 1 Solar Energy Facility based on supplied information specific to the project and as such, it is the opinion of the authors that the proposed development can be authorised on condition that the recommendations and proposed mitigation measures be implemented in order to ensure any impact on receiving water resources can be limited as far as possible.



Luke Wiles

(MSc, PrSciNat)

Project Manager/Author/Reviewer



Bjorn Wikstrom

(MSc)

Project Author



Mark Bollaert

(MSc, PrSciNat)

Project Author

DISCLAIMER

Although Highlands Hydrology (Pty) Ltd exercises due care and diligence in rendering services and preparing documents, Highlands Hydrology (Pty) Ltd accepts no liability, and the client, by receiving this document, indemnifies Highlands Hydrology (Pty) Ltd and its members, managers, sub-contractors, agents and employees against all actions, claims, demands, losses, liabilities, costs, damages and expenses arising from or in connection with services rendered, directly or indirectly by Highlands Hydrology (Pty) Ltd and by the use of the information contained in this document.

6 REFERENCES

- Bailey, A.K. and Pitman, W.V., 2015, “*Water Resources of South Africa 2012 Study (WR2012)*”, WRC Report No. TT, Water Research Commission, Pretoria
- Chow, V.T., 1959, “*Open-Channel Hydraulics*”, McGraw-Hill, New York
- Department of Water Affairs and Forestry, 1998. *National Water Act, Act 36 of 1998*
- Department of Water Affairs and Forestry, 1999. *Government Notice 704 (Government Gazette 20118 of June 1999)*
- Department of Water Affairs and Forestry, 2006, “*Best Practice Guideline No. G1: Storm Water Management*”, DWAF, Pretoria, August 2006
- HRU – Hydrological Research Unit, 1978, “*A Depth-Duration-Frequency Diagram for Point Rainfall in southern Africa*”, Report 2/78, University of Witwatersrand, Johannesburg, South Africa
- Lynch, S.D., 2004, “*Development of a Raster Database of Annual, Monthly and Daily Rainfall for Southern Africa*”. WRC Report 1156/1/04. Water Research Commission, Pretoria, South Africa.
- Pegram, G.G.S., Sinclair, S. and Bárdossy, A., 2016, “*New Methods of Infilling Southern African Rain gauge Records Enhanced by Annual, Monthly and Daily Precipitation Estimates Tagged with Uncertainty*”
- Rossmann, L., 2008. Storm Water Management Model user’s manual, version 5.0, (March), 271. Retrieved from <http://nepis.epa.gov/Exe/ZyPURL.cgi?Dockey=P10011XQ.txt>
- SANBI - South African National Biodiversity Institute, 2018, “*Vegetation Map of South Africa, Lesotho and Swaziland 2018*”
- SANRAL., 2013 “*Drainage Manual - Sixth Edition*”, The South African National Roads Agency Limited, Pretoria.
- Schulze, R.E. and Lynch, S.E., 2006. “*South African Atlas of Climatology and Agrohydrology*”, WRC Report 1489/1/06, Water Research Commission, Pretoria
- Smithers, J.C. and Schulze, R.E., 2000, “*Long Duration Design Rainfall Estimates for South Africa*”, WRC Report No. 811/1/00, Water Research Commission, Pretoria
- USACE (United States Army Corps of Engineers). 2016. “*HEC-RAS River Analysis System – 2D Modelling User Manual*”, Institute for Water Resources, Davis, California.
- USACE (United States Army Corps of Engineers), 2016, “*Benchmarking of the HEC-RAS Two-Dimensional Hydraulic Modeling Capabilities*”, Davis, California
- Water Research Commission 2002. Design Rainfall Estimation in South Africa. WRC Report No. K5/1060

APPENDIX A: STORM WATER CALCULATIONS

A.1 MODEL CHOICE

PCSWMM is a model package that makes use of the USEPA Storm Water Management Model (SWMM), which is a computer program that computes dynamic rainfall-runoff from developed urban and undeveloped or rural areas (Rossman, 2008).

The SWMM model suits application to this project since it can account for:

- Time-varying rainfall;
- Rainfall interception in depression storage;
- Infiltration of rainfall into unsaturated soil layers;
- Evaporation of standing surface water;
- Routing of overland flow; and
- Capture and retention of rainfall/runoff.

The development of SWMP's using SWMM have been undertaken for many thousands of studies through the world including (Rossman, 2008) South Africa.

A.2 DESIGN HYDROGRAPHS

A.2.1 DESIGN STORM

In assessing the storm water management, it was necessary to define the associated rainfall that would cause this flooding. A hypothetical storm consequently needed to be developed which utilised the depth-duration-frequency (DDF) data provided by DRESSA (see Section 2.2). This hypothetical storm is the design rainfall that will produce the highest peak flow at each location independent of catchment response time (which is the index of the rate at which stormflow moves through a catchment). To calculate the hypothetical storm, the DRESSA 1:50 year RI rainfall depth for various durations (e.g. 5 minutes, 30 minutes and 2 hours) was transformed into a synthetic rainfall distribution or design hyetograph.

A.2.2 MODEL PARAMETERISATION

The 30m DSM was used to identify sub-catchments. Land cover parameters were estimated according to the surface infrastructure layout with the baseline land cover and soil type being set according to Section 2.6

A.2.2 MODEL RUN

Dynamic wave routing was set for the model run along with a variable time step. The resulting runoff and routing continuity errors of 0.0 and 0% which is optimum. The peak flows and characteristics for the sub-catchment of interest is presented in Table A-1

TABLE A-0-1: SUB-CATCHMENT CHARACTERISTICS FOR THE 1:50 YEAR EVENT UNLESS INDICATED

Name	Area (ha)	Precipitation (mm)	Infiltration (mm)	Runoff Coefficient	Runoff Volume (ML)	Peak Runoff (m ³ /s)
D01	27.6	76.8	37.8	0.49	10.3	1.0
D02	9.1	76.8	37.4	0.50	3.5	1.3
D03	1.7	76.8	37.3	0.50	0.7	0.3
D04	33.2	76.8	37.1	0.49	12.6	1.2
D05	15.6	76.8	37.7	0.49	5.9	1.2
D06	49.1	76.8	37.8	0.48	18.2	1.5
D07	35.3	76.8	37.8	0.49	13.3	1.7
D08	65.3	76.8	37.8	0.48	24.2	1.8
D09	32.4	76.8	37.8	0.48	12.0	0.8
D10	41.4	76.8	37.8	0.48	15.4	1.3
D12	24.1	76.8	37.8	0.49	9.0	0.9
D13	68.8	76.8	37.8	0.49	25.7	2.6
D14	40.2	76.8	37.8	0.49	15.1	2.0
C01	67.0	76.8	37.8	0.48	24.9	2.0
C02	27.7	76.8	37.8	0.49	10.4	1.1
C03	44.5	76.8	37.8	0.48	16.5	1.3
N01	248.2	76.8	28.0	0.61	115.7	12.8
N02	116.7	76.8	30.7	0.58	51.7	7.9
N03	136.3	76.8	32.6	0.55	57.5	5.7
N04	9.5	76.8	28.6	0.60	4.4	0.6
N05	24.5	76.8	37.8	0.59	13.7	3.3
N06	13.8	76.8	37.8	0.85	30.0	2.3
N07	43.1	76.8	37.8	0.48	15.9	1.1
N08	150.3	76.8	28.4	0.60	69.2	6.4
N09	55.0	76.8	35.0	0.52	22.0	2.1
N10	35.5	76.8	37.8	0.49	13.4	2.3
N11	129.2	76.8	37.3	0.49	48.4	3.2
N12	30.8	76.8	37.8	0.49	11.6	1.8
N13	199.7	76.8	30.9	0.56	86.0	4.9
N14	174.5	76.8	28.0	0.61	81.3	9.0
N15	213.6	76.8	30.1	0.58	94.5	7.5
N16	49.0	76.8	34.1	0.54	20.1	2.8
N17	53.8	76.8	37.8	0.50	21.7	1.8
N18	58.6	76.8	37.8	0.62	38.4	3.9
N19	4.2	76.8	34.3	0.54	1.7	0.4
N20	12.3	76.8	29.9	0.59	5.6	1.1
S01*	4.8	54.2	12.6	0.74	1.9	0.7
S02*	1.8	54.2	12.6	0.75	0.7	0.3
S03*	2.8	54.2	12.6	0.74	1.1	0.5
S04*	3.7	54.2	12.6	0.74	1.5	0.6

* 1:10 year RI event used

APPENDIX B: CURRICULUM VITAE

Hydrologist

Qualifications

PrSciNat	2010	Earth Sciences - Registration No. 400123/10
MSc	2006	Hydrology, University of KwaZulu Natal
BSc (Honours)	2003	Hydrology, University of KwaZulu Natal
BSc	2002	Hydrology, Soil Science, Geography, University of Natal

Key Areas of Expertise

Key areas of expertise are summarised below.

Flood Hydrology	Catchment delineation, flood calculations for a range of return periods to meet specific environmental requirements as part of the authorization process
Hydraulic Modelling	Development and review of 1D, 2D and 1D/2D hydraulic models for fluvial and storm water investigations, including floodline delineation for various return periods, up to the probable maximum
Catchment Modelling	Modelling of hydrological catchments for the purposes of defining average and low-flow conditions, as well as the impact of land use change
Storm Water Management Systems	Storm water management systems designed as per requirements of GN 704, best practice and IFC guidance
Surface Water Impact assessments	As part of the EIA process, impact assessments related to surface water
Water Quality Monitoring	Surface and groundwater monitoring as per authorised or investigative monitoring programs including sampling, analysis and interpretation
Water Use Licensing	Integrated water use license applications according to DWS standards
Mine Wide Water Balances	Development and evaluation of static mine wide water balances
Integrated Mine Water Management	Integrated understanding of the relationship between local climate (rainfall and evaporation) surface and ground waters, mine wide water balance and stormwater management plans for the optimal use of waters as per the hierarchy of water use defined by the National Water Act (Act 36 of 1998).
Compliance Auditing (GN 704 and IWULA)	Auditing of current operations according to GN 704 and DWS Best Practice Guidelines. Compliance auditing based on DWS issued water licenses
Integrated Catchment Management	Management of the Bierspruit hydrological catchment while at DWS to assess the individual and cumulative impacts of mining operations on water resources
Project Management	Project management skill developed to handle projects from proposal to report completion, including client, relevant authority and multidisciplinary team coordination

Summary of Experience

Luke has 16 years of experience working firstly as a hydrologist for then Department of Water Affairs and Forestry (DWAF, now DWS) where his responsibilities included catchment management in line with the National Water Act of 1998 (Act 36 of 1998). In 2008, Luke joined Metago (now SLR) as a hydrologist working primarily on projects within South Africa, but also including Mozambique, Zimbabwe, Namibia, Tanzania, Ethiopia, Botswana, Papua New Guinea and the Democratic Republic of Congo.

As of October 2011, Luke became an independent consultant, working through his company, Highlands Hydrology (Pty) Ltd

Recent Project Experience

Some of Luke's more recent project experience is summarised below and includes a combination of roles as presented in the key areas of expertise.

Client	Project	Country	Year
Red Rocket	Hydrological Assessment of various Wind Energy Facilities, Western Cape	South Africa	2023
Glencore	GN704 and Storm Water Management Audits for the Glencore Eastern Chrome Mines	South Africa	2023
ADA Consulting	Flood Model for the proposed Lotsane Lodge	Botswana	2022
ECA Consulting	Hydrological Assessment including Storm Water Management, Water Balance and Impact Assessment for the Proposed Bux Housing Development	South Africa	2022
Glencore	Glencore Lion Climatic, Hydrological and Hydrotechnical Assessment	South Africa	2022
Illovo Sugar	Various Hydrological Assessments to inform irrigation potential	South Africa	2022
Anglo American	Waterval Smelter and ACP Storm Water Management Review	South Africa	2022
Doveton Farms	Hydrological Assessment and Water Use License Application for Doveton Farms	South Africa	2021
DRDGold	Hydrological Assessment for the Proposed Regional Tailings Facility, Far West Gold Recoveries	South Africa	2020
Northam Platinum	Conceptual Storm Water Management Plan for Maroelabult Section,	South Africa	2020
Anglo Platinum	Hydrological Assessment for the Unki Platinum Mine	Zimbabwe	2020
Glencore	Glencore Rhovan and Lydenburg Climate and Hydrological Assurance Assessment	South Africa	2019
Khoemacau Copper Mine	Hydrological Flow Model and Conceptual Storm Water Management Plan for the Khoemacau Copper Mine	Botswana	2019
Klipspruit Colliery	Hydrological Assessment of the Northern Road Realignment	South Africa	2019
Sabi Sabi Private Game Reserve	Earth Lodge Flood Study	South Africa	2019
Exxaro	Hydrological Assessment of the Exxaro Kalabasfontein Project	South Africa	2019
DRDGold	Withok Tailings Complex Storm Water Management Plan	South Africa	2018
Harmony Gold Mining	Hydrological Assessment of the St Helena Shaft	South Africa	2018