

Stephan Jacobs

From: Natasha Higgitt <nhiggitt@sahra.org.za>
Sent: Wednesday, 29 January 2020 8:34 AM
To: sivist_PPP
Cc: Stephan Jacobs; Liandra Scott-Shaw; 'Sheldon.vandrey@edf-re.co.za'
Subject: RE: Umsobomvu Power Lines and Substations near Noupoot and Middelburg – BID Notification

Follow Up Flag: Follow up
Flag Status: Flagged

Good morning,

Please note that all development applications are processed via our online portal, the South African Heritage Resources Information System (SAHRIS) found at the following link: <http://sahra.org.za/sahris/>. We do not accept emailed, posted, hardcopy, faxed, website links or DropBox links as official submissions.

Please create an application on SAHRIS and upload all documents pertaining to the Environmental Authorisation Application Process. As per section 38(8) of the National Heritage Resources Act, Act 25 of 1999 (NHRA), an assessment of heritage resources must form part of the process and the assessment must comply with section 38(3) of the NHRA.

Once all documents including all appendices are uploaded to the case application, please ensure that the status of the case is changed from DRAFT to SUBMITTED. Please ensure that all documents produced as part of the EA process are submitted as part of the application, and are submitted to SAHRA at the beginning of the Public Review periods. Once all these documents have been uploaded, I will be able to issue an informed comment as per section 38(4) and 38(8) of the NHRA.

From: sivist_PPP <sivist_ppp@sivist.co.za>
Sent: Tuesday, 28 January 2020 15:44
Cc: Stephan Jacobs <StephanJ@sivist.co.za>; Liandra Scott-Shaw <LiandraS@sivist.co.za>; 'Sheldon.vandrey@edf-re.co.za' <Sheldon.vandrey@edf-re.co.za>
Subject: Umsobomvu Power Lines and Substations near Noupoot and Middelburg – BID Notification

Dear Interested and/or Affected Party (I&AP) / Stakeholder,

Please find attached for your attention.
Please do not hesitate to contact us should you have any queries in this regard.”

Geagte Belangstellende en/of Geaffekteerde Party / Belanghebbende,

Vind asseblief aangeheg vir u aandag.
Moet asseblief nie huiwer om ons te kontak indien u enige navrae in hierdie verband het nie.

Kind Regards,
Stephan Jacobs (B.Sc. (Hons) Environmental Management and Analysis)
Environmental Consultant / Visual Specialist
SiVEST Environmental Division

sivest_PPP

From: Eustacia Fillis <eustacia.pf@gmail.com>
Sent: 30 January 2020 05:36 PM
To: sivest_PPP; Rosie Lottering
Subject: Re: Umsobomvu Power Lines and Substations near Noupoot and Middelburg – BID Notification
Attachments: Picture (Device Independent Bitmap) 1.jpg

Hi

I sent it to Mr Matoto's(the Unit Manager) email address but he has got problems with his emails.

I think you can send this to the councillors?

Their email addresses are as follows:

- Vuyisilebene@gmail.com
- Thulanimisali@gmail.com
- Sibongilevictor@gmail.com
- Handri.vorster@gmail.com
- Adasammy20@gmail.com
- Monedesha@gmail.com
- Rosiel@da.org.za

Regards

E.P. Fillis

On Tue, 28 Jan 2020, 3:46 PM sivest_PPP, <sivest_ppp@sivest.co.za> wrote:
Dear Interested and/or Affected Party (I&AP) / Stakeholder,

Please find attached for your attention.
Please do not hesitate to contact us should you have any queries in this regard.”

Geagte Belangstellende en/of Geaffekteerde Party / Belanghebbende,

Vind asseblief aangeheg vir u aandag.
Moet asseblief nie huiwer om ons te kontak indien u enige navrae in hierdie verband het nie.

Kind Regards,
Stephan Jacobs (B.Sc. (Hons) Environmental Management and Analysis)
Environmental Consultant / Visual Specialist
SIVEST Environmental Division



SIVEST is a Level 3 BBBEE Contributor

D +27 11 798 0677 | **T** +27 011 798 0600 **E** stephanj@sivest.co.za | **W** www.sivest.co.za
Engineering Consulting | Project Management | Environmental Consulting | Town & Regional Planning | Management Systems Consulting
Durban | Johannesburg | Pretoria | Pietermaritzburg | Richards Bay | Port Louis (Mauritius)

Disclaimer

The information contained in this communication from the sender is confidential. It is intended solely for use by the recipient and others authorized to receive it. If you are not the recipient, you are hereby notified that any disclosure, copying, distribution or taking action in relation of the contents of this information is strictly prohibited and may be unlawful.

This email has been scanned for viruses and malware, and automatically archived by **Mimecast SA (Pty) Ltd**, an innovator in Software as a Service (SaaS) for business. **Mimecast Unified Email Management ??? (UEM)** offers email continuity, security, archiving and compliance with all current legislation. To find out more, [contact Mimecast](#).

Stephan Jacobs

From: John Geeringh <GeerinJH@eskom.co.za>
Sent: Monday, 03 February 2020 12:49 PM
To: Stephan Jacobs
Subject: RE: 15324 Three (3) grid connection projects (substations and power lines) near Noupoort and Middelburg: KMLs of proposed power line routes and substation sites

Thanks
John



From: Stephan Jacobs [mailto:StephanJ@sivest.co.za]
Sent: 03 February 2020 12:15 PM
To: John Geeringh
Cc: Liandra Scott-Shaw; Hlengiwe Ntuli; Kerry Schwartz; Sheldon Vandrey
Subject: RE: 15324 Three (3) grid connection projects (substations and power lines) near Noupoort and Middelburg: KMLs of proposed power line routes and substation sites
Importance: High

Good Afternoon Mr Geeringh,

I trust you are well.

The Basic Assessment (BA) processes for the proposed Mooi Plaats, Wonderheuvel and Paarde Valley grid connection developments (substation and overhead power lines) near Noupoort and Middelburg in the Northern and Eastern Cape Provinces refer. These proposed developments form part of the greater Umsobomvu PV project (which also includes the Mooi Plaats – [14/12/16/3/3/2/1134](#), Wonderheuvel - [14/12/16/3/3/2/1135](#) and Paarde Valley - [14/12/16/3/3/2/1136](#) Solar PV Energy Facilities).

As requested in the email below, please find attached KML files of the proposed grid connections for each project, along with the affected properties.

These attached KMLs show all alternatives for the proposed substation sites and overhead power line corridor routes. However, based on the result of the comparative assessment of alternatives for the respective projects, the following alternatives are preferred:

Mooi Plaats Grid:

- Grid Connection Option 1a (132kV overhead power line route);
- Substation 1a (Northern Collector Substation); and
- Substation 2 (On-site Substation).

Wonderheuvel Grid:

- Grid Connection Option 3 (132kV overhead power line route);
- Substation 4a (Central Collector Substation); and
- Substation 4b (On-site Substation).

Paarde Valley Grid:

- Grid Connection Option 2a (132kV overhead power line route);
- Substation 5 (On-site Substation);
- Substation 6a (Southern Collector Substation) and
- Substation 7a (On-site Substation).

It should be noted that the substation sites are intrinsically linked to the grid connection infrastructure alternatives. The locations for the on-site and collector substation sites being proposed have been informed by the grid connection infrastructure alternatives which have been chosen as 'preferred' by the respective specialists. Please see attached PDF document (project description) explaining how the respective grid connection infrastructure alternatives work.

For **Mooi Plaats**, Grid Connection Option 1a has been selected as the preferred grid connection infrastructure alternative and thus Substation 1a (Northern Collector) and Substation 2 (On-site) are being proposed, as these are intrinsically linked to this grid connection infrastructure alternative.

For **Wonderheuvel**, Grid Connection Option 3 has been selected as the preferred grid connection infrastructure alternative and thus Substation 4a (Central Collector) and Substation 4b (On-site) are being proposed, as these are intrinsically linked to this grid connection infrastructure alternative.

For **Paarde Valley**, Grid Connection Option 2a has been selected as the preferred grid connection infrastructure alternative and thus Substation 5 (On-site), Substation 6a (Southern Collector) and Substation 7a (On-site) are being proposed, as these are intrinsically linked to this grid connection infrastructure alternative.

The substation site alternatives being proposed as part of the BA application also align with the preferences for the substation sites associated with the proposed Mooi Plaats, Wonderheuvel and Paarde Valley Solar PV Energy Facility EIAs [proposed substations include an Eskom portion and an Independent Power Producer (IPP) portion, hence the substations have been included in the solar PV energy facility EIAs and in the grid infrastructure BAs to allow for handover to Eskom].

The information above has been explained in the Draft Basic Assessment Reports (DBARs), which SiVEST are planning on submitting on Friday 07 February 2020. You will receive a notification regarding the availability of the DBARs, once they have been submitted.

I trust you will find everything is in order.

Please do not hesitate to contact us should there be any issues or should you have any queries in this regard.

Kind Regards,

Stephan Jacobs (B.Sc. (Hons) Environmental Management and Analysis)

Environmental Consultant / Visual Specialist

SiVEST Environmental Division



SiVEST is a Level 3 BBBEE Contributor

D +27 11 798 0677 | **T** +27 011 798 0600 | **M** +27 72 737 2114 **E** stephanj@sivest.co.za | **W** www.sivest.co.za

From: John Geeringh [mailto:GeerinJH@eskom.co.za]
Sent: Monday, 29 July 2019 1:51 PM
To: Stephan Jacobs <StephanJ@sivest.co.za>
Subject: RE: 15324 Three (3) Solar PV Energy Facilities near Noupoort and Middelburg: DSR Comment Period Starting

I can just mention we have had interaction with the EDF team regarding this applications and I do have a good idea of what is coming in future. I just need to have the actual plans when you are at the point where routes and layouts are determined, so that we can interact if necessary. EDF is aware of the setbacks issue and we have discussed it with them previously.

Regards
John

From: Stephan Jacobs [mailto:StephanJ@sivest.co.za]
Sent: 29 July 2019 01:04 PM
To: John Geeringh
Cc: Andrea Gibb; sivest_PPP; Hlengiwe Ntuli
Subject: RE: 15324 Three (3) Solar PV Energy Facilities near Noupoort and Middelburg: DSR Comment Period Starting
Importance: High

Good Afternoon Mr Geeringh,

Thank you for your email and the attachments. We will ensure that these are forwarded to the applicant for consideration.

As requested, please find attached KML/KMZ files of the affected properties for the respective proposed solar Photovoltaic (PV) energy facilities.

Please be advised that the proposed grid connections will be assessed as part of separate Basic Assessment (BA) processes which will only commence at a later stage, and thus the layouts we have at this stage are only preliminary. We will therefore forward you KML/KMZ files for the grid connections when we commence the BA processes for the grid connections. We will also send you another notification when these BA processes commence. I trust this is in order.

Please do not hesitate to contact me should there be any issues or should you have any queries in this regard.

Kind Regards,

Stephan Jacobs (B.Sc. (Hons) *Environmental Management and Analysis*)
Environmental Consultant / Visual Specialist
SIVEST Environmental Division



SiVEST is a Level 3 BBBEE Contributor

D +27 11 798 0677 | **T** +27 011 798 0600 | **M** +27 72 737 2114 **E** stephanj@sivest.co.za | **W** www.sivest.co.za

Engineering Consulting | Project Management | Environmental Consulting | Town & Regional Planning | Management Systems Consulting
Durban | Johannesburg | Pretoria | Pietermaritzburg | Richards Bay | Port Louis (Mauritius)

From: John Geeringh [<mailto:GeerinJH@eskom.co.za>]

Sent: Monday, 29 July 2019 9:25 AM

To: sivest_PPP <sivest_ppp@sivest.co.za>

Cc: Andrea Gibb <AndreaG@sivest.co.za>; Stephan Jacobs <StephanJ@sivest.co.za>

Subject: RE: 15324 Three (3) Solar PV Energy Facilities near Noupoort and Middelburg: DSR Comment Period Starting

Please find attached Eskom requirements for works at or near Eskom infrastructure. Please also find attached the Eskom setbacks document that regulates the setback distance for RE plant from Eskom infrastructure.

Please send me a KMZ file of the affected properties and proposed Grid connections.

Kind regards

John Geeringh (Pr Sci Nat)
Senior Consultant Environmental Management
Group Capital Division: Land Development and Management
Megawatt Park, D1Y42, Maxwell Drive, Sunninghill, Sandton.
P O Box 1091, Johannesburg, 2000.
Tel: 011 516 7233
Cell: 083 632 7663
Fax: 086 661 4064
E-mail: john.geeringh@eskom.co.za



From: sivest_PPP [mailto:sivest_ppp@sivest.co.za]

Sent: 26 July 2019 03:35 PM

Cc: Andrea Gibb; Stephan Jacobs

Subject: 15324 Three (3) Solar PV Energy Facilities near Noupoort and Middelburg: DSR Comment Period Starting

Dear Interested and/or Affected Party

ENVIRONMENTAL IMPACT ASSESSMENT PROCESS (EIA) AND BASIC ASSESSMENTS (BAS) FOR THE PROPOSED DEVELOPMENT OF THREE (3) SOLAR PHOTOVOLTAIC (PV) ENERGY FACILITIES AND ASSOCIATED GRID INFRASTRUCTURE NEAR NOUPOORT AND MIDDELBURG IN THE NORTHERN AND EASTERN CAPE PROVINCES

- **MOOI PLAATS SOLAR PV – (DEA Ref No.: To be Announced)**

- **WONDERHEUVEL SOLAR PV – (DEA Ref No.: To be Announced)**
- **PAARDE VALLEY SOLAR PV – (DEA Ref No.: To be Announced)**
- **MOOI PLAATS GRID – (DEA Ref No.: To be Announced)**
- **WONDERHEUVEL GRID – (DEA Ref No.: To be Announced)**
- **PAARDE VALLEY GRID – (DEA Ref No.: To be Announced)**

Please note that SIVEST SA (Pty) Ltd has been appointed as the Environmental Assessment Practitioner (EAP) for the abovementioned projects.

We would like to take this opportunity to inform you that, in accordance with the National Environmental Management Act, 1998 (Act No. 107 of 1998) (NEMA) (as amended), the Draft Scoping Reports (DSRs) for the above mentioned projects will be available for public comment and review as from **Friday 26 July 2019 to Monday 26 August 2019** (end of business day). Should you wish to receive an electronic copy of the DSRs (on CD) please forward your request in writing to us. Hard copies of the DSRs can be reviewed at the following public places:

| VENUE | REPORT/S | STREET ADDRESS | HOURS | CONTACT NO |
|--------------------|-------------------------------------------|----------------------------------------|--------------------------------------------------------|--------------|
| Noupoort Library | Mooi Plaats PV DSR Wonderheuvel PV DSR | Shaw St, Noupoort, 5950 | Mondays - Fridays 10:00 - 13:00 13:45 - 16:30 | 049 843 1056 |
| Middelburg Library | Paarde Valley PV DSR | 47 Van Reenen Street, Middelburg, 5900 | Mondays - Fridays 09:00 - 16:30 | 049 802 1300 |

The reports as well as the accompanying appendices are also available on SIVEST's website: <http://www.sivest.co.za/>, click on Downloads, then browse to the folder '15324 Umsobomvu PV and Grid'.

Attached is an English and Afrikaans letter notifying you of the review period as well as the background information document (BID).

Kind Regards,
Stephan Jacobs (B.Sc. (Hons) Environmental Management and Analysis)
 Environmental Consultant / Visual Specialist
SIVEST Environmental Division

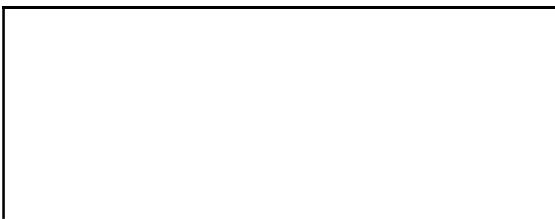

SIVEST is a Level 3 BBBEE Contributor

D +27 11 798 0677 | **T** +27 011 798 0600 **E** stephanj@sivest.co.za | **W** www.sivest.co.za
Engineering Consulting | Project Management | Environmental Consulting | Town & Regional Planning | Management Systems Consulting
Durban | Johannesburg | Pretoria | Pietermaritzburg | Richards Bay | Port Louis (Mauritius)

Disclaimer

The information contained in this communication from the sender is confidential. It is intended solely for use by the recipient and others authorized to receive it. If you are not the recipient, you are hereby notified that any disclosure, copying, distribution or taking action in relation of the contents of this information is strictly prohibited and may be unlawful.

This email has been scanned for viruses and malware, and automatically archived by **Mimecast SA (Pty) Ltd**, an innovator in Software as a Service (SaaS) for business. **Mimecast Unified Email Management ??? (UEM)** offers email continuity, security, archiving and compliance with all current legislation. To find out more, [contact Mimecast](#).

NB: This Email and its contents are subject to the Eskom Holdings SOC Ltd EMAIL LEGAL NOTICE which can be viewed at http://www.eskom.co.za/Pages/Email_Legal_Spam_Disclaimer.aspx

Disclaimer

The information contained in this communication from the sender is confidential. It is intended solely for use by the recipient and others authorized to receive it. If you are not the recipient, you are hereby notified that any disclosure, copying, distribution or taking action in relation of the contents of this information is strictly prohibited and may be unlawful.

This email has been scanned for viruses and malware, and automatically archived by **Mimecast SA (Pty) Ltd**, an innovator in Software as a Service (SaaS) for business. **Mimecast Unified Email Management ??? (UEM)** offers email continuity, security, archiving and compliance with all current legislation. To find out more, [contact Mimecast](#).

NB: This Email and its contents are subject to the Eskom Holdings SOC Ltd EMAIL LEGAL NOTICE which can be viewed at http://www.eskom.co.za/Pages/Email_Legal_Spam_Disclaimer.aspx

Disclaimer

The information contained in this communication from the sender is confidential. It is intended solely for use by the recipient and others authorized to receive it. If you are not the recipient, you are hereby notified that any disclosure, copying, distribution or taking action in relation of the contents of this information is strictly prohibited and may be unlawful.

This email has been scanned for viruses and malware, and automatically archived by **Mimecast SA (Pty) Ltd**, an innovator in Software as a Service (SaaS) for business. **Mimecast Unified Email Management ??? (UEM)** offers email continuity, security, archiving and compliance with all current legislation. To find out more, [contact Mimecast](#).

NB: This Email and its contents are subject to the Eskom Holdings SOC Ltd EMAIL LEGAL NOTICE which can be viewed at http://www.eskom.co.za/Pages/Email_Legal_Spam_Disclaimer.aspx

sivest_PPP

From: Ontvangs <ontvangs@agrink.co.za>
Sent: 11 February 2020 09:12 AM
To: Noupoort LU : SP van der Walt
Cc: sivest_PPP
Subject: 15324 Three (3) Solar PV Energy Facilities and Grid Infrastructures near Noupoort and Middelburg: DBAR Comment Period Starting

Goeie dag

Sien asseblief meegaande dokumentasie vir jul kennisname en verdere hantering indien nodig.

Baie dankie

Vriendelike groete

Lucelle van Niekerk

ONTVANGS : AGRI NOORD-KAAP

E-pos : ontvangs@agrink.co.za

Tel : (053) 83 29595

Faks : (053) 83 27126



From: sivest_PPP [mailto:sivest_ppp@sivest.co.za]
Sent: Monday, February 10, 2020 5:04 PM
Cc: Stephan Jacobs <StephanJ@sivest.co.za>; Liandra Scott-Shaw <LiandraS@sivest.co.za>; 'Sheldon.vandrey@edf-re.co.za' <Sheldon.vandrey@edf-re.co.za>
Subject: 15324 Three (3) Solar PV Energy Facilities and Grid Infrastructures near Noupoort and Middelburg: DBAR Comment Period Starting

Dear Interested and/or Affected Party (I&AP),

BASIC ASSESSMENTS (BAs) FOR THE PROPOSED DEVELOPMENT OF THE THREE (3) GRID CONNECTION INFRASTRUCTURE DEVELOPMENTS (SUBSTATIONS AND POWER LINES) NEAR NOUPOORT AND MIDDELBURG IN THE NORTHERN AND EASTERN CAPE PROVINCES

- **Mooi Plaats Grid – (DEA Ref No: To be announced)**
- **Wonderheuvel Grid – (DEA Ref No: To be announced)**
- **Paarde Valley Grid – (DEA Ref No: To be announced)**

Please note that SiVEST SA (Pty) Ltd has been appointed as the independent Environmental Assessment Practitioner (EAP) to undertake the Basic Assessment (BA) processes for the above-mentioned proposed projects.

We would like to take this opportunity to inform you that, in accordance with the National Environmental Management Act, 1998 (Act No. 107 of 1998) (NEMA) (as amended), the Draft Basic Assessment Reports (DBARs) for the above-mentioned proposed projects will be available for public comment and review as from **Monday the 10th of February 2020 to Wednesday the 11th of March 2020** (end of business day). Should you wish to receive an electronic copy of the DBARs (on CD), please forward your request in writing to us. Comments can be submitted to:

Hlengiwe Ntuli
PO Box 2921, RIVONIA, 2128
Phone: (011) 798 0600
E-mail: sivest_ppp@sivest.co.za / hlengiwen@sivest.co.za / stephanj@sivest.co.za
Fax: (011) 803 7272

Hard copies of the DBARs can be reviewed at the following public places:

| VENUE | REPORT(S) | STREET ADDRESS | HOURS | CONTACT NO |
|---------------------------|---------------------------------------------------|----------------------------------------|------------------------------------------------------------|--------------|
| Noupoort Public Library | Mooi Plaats Grid DBAR | Shaw St, Noupoort, 5950 | Mondays - Fridays 10:00 - 13:00 13:45 - 16:30 | 049 843 1056 |
| Middelburg Public Library | Wonderheuvel Grid DBAR Paarde Valley Grid DBAR | 47 Van Reenen Street, Middelburg, 5900 | Mondays - Fridays 09:00 - 16:30 | 049 802 1300 |

The reports as well as the accompanying appendices are also available on SiVEST's website: <http://www.sivest.co.za/>, click on 'Downloads', then browse to the folder '15324 Umsobomvu PV and Grid'. Please reference 'Mooi Plaats / Wonderheuvel / Paarde Valley Grid' in your correspondence, should your comments be project specific.

We would like to thank you in anticipation of your active and meaningful contribution to the BA and public participation processes.

Geagte Belangstellende en/of Geaffekteerde Party,

BASIESE EVALUERINGS (BEs) VIR DIE BEOOGDE ONTWIKKELING VAN DIE DRIE (3) NETWERKVERBINDINGSINFRASTRUKTUURONTWIKKELINGS (SUBSTASIES EN KRAGLYNE) NABY NOUPOORT EN MIDDELBURG IN DIE NOORD- EN OOS-KAAPROVINSIES

- MOOI PLAATS SUBSTASIES EN KRAGLYN – (DO-verw. No.: Moet nog aangekondig word)
- WONDERHEUVEL SUBSTASIES EN KRAGLYN – (DO-verw. No.: Moet nog aangekondig word)
- PAARDE VALLEY SUBSTASIES EN KRAGLYN – (DO-verw. No.: Moet nog aangekondig word)

Ons stel u graag in kennis dat SiVEST SA (Edms) Bpk aangestel is as die onafhanklike Omgewingsevalueringspraktisyn (OEP) om die Basiese Evalueerings- (BE) prosesse vir die bogenoemde voorgestelde projekte te onderneem.

Ons wil graag van hierdie geleentheid gebruik maak om u in te lig dat ingevolge die Nasionale Wet op Omgewingsbestuur (NEMA) (Wet No. 107 van 1998) (soos gewysig), sal die Konsep Basiese Evalueeringsverslae (KBEVs) vir die bogenoemde voorgestelde projekte vanaf **Maandag 10 Februarie 2020** tot **Woensdag 11 Maart 2020** (teen sluitingstyd) beskikbaar wees vir openbare kommentaar en insae. As u elektroniese kopie van die KBEVs (op CD) wil ontvang, moet u dit asseblief skriftelik by ons versoek. Kommentaar kan soos volg ingedien word:

Hlengiwe Ntuli

Posbus 2921, RIVONIA, 2128

Foon: (011) 798 0600

E-pos: sivest_ppp@sivest.co.za / hlengiwen@sivest.co.za / stephanj@sivest.co.za

Faks: (011) 803 7272

Gedrukte kopie van die KBEVs kan by die volgende openbare plekke nagegaan word:

| PLEK | VERSLAG / VERSLAE | STRAATADRES | TYE | KONTAKNOMMERS |
|--------------------------------------|---------------------------------------------------------------------------------------------------|---------------------------------------------|--------------------------------------|---------------|
| Noupoort Publieke Biblioteek | Mooi Plaats Substasie en Kraglyn KBEV | Shawstraat, Noupoort, 5950 | Maandae - Vrydae | 049 843 1056 |
| | | | 10:00 - 13:00 13:45 - 16:30 | |
| Middelburg Publieke Biblioteek | Wonderheuvel Substasie en Kraglyn KBEV Paarde Valley Substasie en Kraglyn KBEV | Van Reenenstraat 47, Middelburg, 5900 | Maandae - Vrydae | 049 802 1300 |
| | | | 09:00 - 16:30 | |

Die verslae, sowel as die meegaande aanhangsels, is ook beskikbaar op SiVEST se webwerf: <http://www.sivest.co.za/>, klik op 'Downloads' en soek dan vir die legger '15324 Umsobomvu PV and Grid'. Verwys asseblief 'Mooi Plaats / Wonderheuvel / Paarde Valley Grid' in u korrespondensie, indien u kommentaar spesifiek op die projek is.

Ons dank u byvoorbaat vir u aktiewe en betekenisvolle bydrae tot die BE en Openbare Deelnameprosesse.

Kind Regards,

Stephan Jacobs (B.Sc. (Hons) Environmental Management and Analysis)

Environmental Consultant / Visual Specialist

SiVEST Environmental Division



SiVEST is a Level 3 BBBEE Contributor

D +27 11 798 0677 | **T** +27 011 798 0600 **E** stephanj@sivest.co.za | **W** www.sivest.co.za

Engineering Consulting | Project Management | Environmental Consulting | Town & Regional Planning | Management Systems Consulting
Durban | Johannesburg | Pretoria | Pietermaritzburg | Richards Bay | Port Louis (Mauritius)

Disclaimer

The information contained in this communication from the sender is confidential. It is intended solely for use by the recipient and others authorized to receive it. If you are not the recipient, you are hereby notified that any disclosure, copying, distribution or taking action in relation of the contents of this information is strictly prohibited and may be unlawful.

This email has been scanned for viruses and malware, and automatically archived by **Mimecast SA (Pty) Ltd**, an innovator in Software as a Service (SaaS) for business. **Mimecast Unified Email Management ??? (UEM)** offers email continuity, security, archiving and compliance with all current legislation. To find out more, [contact Mimecast](#).

sivest_PPP

From: xolela Msweli <xwmsweli@iym.gov.za>
Sent: 11 February 2020 11:26 AM
To: 'Sandra Mutangadura'; nzonke@iym.gov.za
Cc: sivest_PPP
Subject: FW: 15324 Three (3) Solar PV Energy Facilities and Grid Infrastructures near Noupoort and Middelburg: DBAR Comment Period Starting

Good day colleagues,

Kindly follow up on the documents as provided herein. You are encouraged to go through the documents as provided at the Library or the Website as per the details provided.

I trust that you will find this communication appropriate if not be at liberty to revert back to the Hlengiwe on the details provided.

Kind regards,

Xolela Msweli

From: sivest_PPP [mailto:sivest_ppp@sivest.co.za]
Sent: Monday, February 10, 2020 5:04 PM
Cc: Stephan Jacobs <StephanJ@sivest.co.za>; Liandra Scott-Shaw <LiandraS@sivest.co.za>; 'Sheldon.vandrey@edf-re.co.za' <Sheldon.vandrey@edf-re.co.za>
Subject: 15324 Three (3) Solar PV Energy Facilities and Grid Infrastructures near Noupoort and Middelburg: DBAR Comment Period Starting

Dear Interested and/or Affected Party (I&AP),

BASIC ASSESSMENTS (BAs) FOR THE PROPOSED DEVELOPMENT OF THE THREE (3) GRID CONNECTION INFRASTRUCTURE DEVELOPMENTS (SUBSTATIONS AND POWER LINES) NEAR NOUPOORT AND MIDDELBURG IN THE NORTHERN AND EASTERN CAPE PROVINCES

- **Mooi Plaats Grid – (DEA Ref No: To be announced)**
- **Wonderheuvel Grid – (DEA Ref No: To be announced)**
- **Paarde Valley Grid – (DEA Ref No: To be announced)**

Please note that SiVEST SA (Pty) Ltd has been appointed as the independent Environmental Assessment Practitioner (EAP) to undertake the Basic Assessment (BA) processes for the above-mentioned proposed projects.

We would like to take this opportunity to inform you that, in accordance with the National Environmental Management Act, 1998 (Act No. 107 of 1998) (NEMA) (as amended), the Draft Basic Assessment Reports (DBARs) for the above-mentioned proposed projects will be available for public comment and review as from **Monday the 10th of February 2020 to Wednesday the 11th of March 2020** (end of business day). Should you wish to receive an electronic copy of the DBARs (on CD), please forward your request in writing to us. Comments can be submitted to:

Hlengiwe Ntuli
PO Box 2921, RIVONIA, 2128
Phone: (011) 798 0600
E-mail: sivest_ppp@sivest.co.za / hlengiwen@sivest.co.za / stephanj@sivest.co.za
Fax: (011) 803 7272

Hard copies of the DBARs can be reviewed at the following public places:

| VENUE | REPORT(S) | STREET ADDRESS | HOURS | CONTACT NO |
|---------------------------|---------------------------------------------------|----------------------------------------|------------------------------------------------------------|--------------|
| Noupoort Public Library | Mooi Plaats Grid DBAR | Shaw St, Noupoort, 5950 | Mondays - Fridays 10:00 - 13:00 13:45 - 16:30 | 049 843 1056 |
| Middelburg Public Library | Wonderheuvel Grid DBAR Paarde Valley Grid DBAR | 47 Van Reenen Street, Middelburg, 5900 | Mondays - Fridays 09:00 - 16:30 | 049 802 1300 |

The reports as well as the accompanying appendices are also available on SiVEST's website: <http://www.sivest.co.za/>, click on 'Downloads', then browse to the folder '15324 Umsobomvu PV and Grid'. Please reference 'Mooi Plaats / Wonderheuvel / Paarde Valley Grid' in your correspondence, should your comments be project specific.

We would like to thank you in anticipation of your active and meaningful contribution to the BA and public participation processes.

Geagte Belangstellende en/of Geaffekteerde Party,

BASIESE EVALUERINGS (BEs) VIR DIE BEOOGDE ONTWIKKELING VAN DIE DRIE (3) NETWERKVERBINDINGSINFRASTRUKTUURONTWIKKELINGS (SUBSTASIES EN KRAGLYNE) NABY NOUPOORT EN MIDDELBURG IN DIE NOORD- EN OOS-KAAPROVINSIES

- **MOOI PLAATS SUBSTASIES EN KRAGLYN – (DO-verw. No.: Moet nog aangekondig word)**
- **WONDERHEUVEL SUBSTASIES EN KRAGLYN – (DO-verw. No.: Moet nog aangekondig word)**
- **PAARDE VALLEY SUBSTASIES EN KRAGLYN – (DO-verw. No.: Moet nog aangekondig word)**

Ons stel u graag in kennis dat SiVEST SA (Edms) Bpk aangestel is as die onafhanklike Omgewingsevalueringspraktisyn (OEP) om die Basiese Evaluerings- (BE) prosesse vir die bogenoemde voorgestelde projekte te onderneem.

Ons wil graag van hierdie geleentheid gebruik maak om u in te lig dat ingevolge die Nasionale Wet op Omgewingsbestuur (NEMA) (Wet No. 107 van 1998) (soos gewysig), sal die Konsep Basiese Evalueringsverslae (KBEVs) vir die bogenoemde voorgestelde projekte vanaf **Maandag 10 Februarie 2020 tot Woensdag 11 Maart 2020** (teen

sluitingstyd) beskikbaar wees vir openbare kommentaar en insae. As u elektroniese kopie van die KBEVs (op CD) wil ontvang, moet u dit asseblief skriftelik by ons versoek. Kommentaar kan soos volg ingedien word:

Hlengiwe Ntuli

Posbus 2921, RIVONIA, 2128

Foon: (011) 798 0600

E-pos: sivest_ppp@sivest.co.za / hlengiwen@sivest.co.za / stephanj@sivest.co.za

Faks: (011) 803 7272

Gedrukte kopie van die KBEVs kan by die volgende openbare plekke nagegaan word:

| PLEK | VERSLAG / VERSLAE | STRAATADRES | TYE | KONTAKNOMMERS |
|--------------------------------------|-----------------------------------------------|---------------------------------------------|--------------------------------------|---------------|
| Noupoort Publieke Biblioteek | Mooi Plaats Substasie en Kraglyn KBEV | Shawstraat, Noupoort, 5950 | Maandae | 049 843 1056 |
| | | | - Vrydae | |
| Middelburg Publieke Biblioteek | Wonderheuvel Substasie en Kraglyn KBEV | Van Reenenstraat 47, Middelburg, 5900 | Maandae | 049 802 1300 |
| | | | - Vrydae | |
| | Paarde Valley Substasie en Kraglyn KBEV | | 10:00 - 13:00 13:45 - 16:30 | |
| | | | 09:00 - 16:30 | |

Die verslae, sowel as die meegaande aanhangsels, is ook beskikbaar op SiVEST se webwerf: <http://www.sivest.co.za/>, klik op 'Downloads' en soek dan vir die legger '15324 Umsobomvu PV and Grid'. Verwys asseblief 'Mooi Plaats / Wonderheuvel / Paarde Valley Grid' in u korrespondensie, indien u kommentaar spesifiek op die projek is.

Ons dank u byvoorbaat vir u aktiewe en betekenisvolle bydrae tot die BE en Openbare Deelnameprosesse.

Kind Regards,

Stephan Jacobs (B.Sc. (Hons) Environmental Management and Analysis)

Environmental Consultant / Visual Specialist

SiVEST Environmental Division



SiVEST is a Level 3 BBBEE Contributor

D +27 11 798 0677 | **T** +27 011 798 0600 **E** stephanj@sivest.co.za | **W** www.sivest.co.za

Engineering Consulting | Project Management | Environmental Consulting | Town & Regional Planning | Management Systems Consulting
Durban | Johannesburg | Pretoria | Pietermaritzburg | Richards Bay | Port Louis (Mauritius)

Disclaimer

The information contained in this communication from the sender is confidential. It is intended solely for use by the recipient and others authorized to receive it. If you are not the recipient, you are hereby notified that any disclosure, copying, distribution or taking action in relation of the contents of this information is strictly prohibited and may be unlawful.

This email has been scanned for viruses and malware, and automatically archived by **Mimecast SA (Pty) Ltd**, an innovator in Software as a Service (SaaS) for business. **Mimecast Unified Email Management ??? (UEM)** offers email continuity, security, archiving and compliance with all current legislation. To find out more, [contact Mimecast](#).

Disclaimer

The information contained in this communication from the sender is confidential. It is intended solely for use by the recipient and others authorized to receive it. If you are not the recipient, you are hereby notified that any disclosure, copying, distribution or taking action in relation of the contents of this information is strictly prohibited and may be unlawful.

This email has been scanned for viruses and malware, and may have been automatically archived by **Mimecast Ltd**, an innovator in Software as a Service (SaaS) for business. Providing a **safer and more useful** place for your human generated data. Specializing in; Security, archiving and compliance. To find out more [Click Here](#).

From: Natasha Higgitt <niggitt@sahra.org.za>
Sent: 11 February 2020 08:03 AM
To: sivest_PPP
Cc: Stephan Jacobs; Liandra Scott-Shaw; 'Sheldon.vandrey@edf-re.co.za'
Subject: RE: 15324 Three (3) Solar PV Energy Facilities and Grid Infrastructures near Noupoort and Middelburg: DBAR Comment Period Starting

Good morning,

Please note that all development applications are processed via our online portal, the South African Heritage Resources Information System (SAHRIS) found at the following link: <http://sahra.org.za/sahris/>. We do not accept emailed, posted, hardcopy, faxed, website links or DropBox links as official submissions.

Please create an application on SAHRIS and upload all documents pertaining to the Environmental Authorisation Application Process. As per section 38(8) of the National Heritage Resources Act, Act 25 of 1999 (NHRA), an assessment of heritage resources must form part of the process and the assessment must comply with section 38(3) of the NHRA.

Once all documents including all appendices are uploaded to the case application, please ensure that the status of the case is changed from DRAFT to SUBMITTED. Please ensure that all documents produced as part of the EA process are submitted as part of the application, and are submitted to SAHRA at the beginning of the Public Review periods. Once all these documents have been uploaded, I will be able to issue an informed comment as per section 38(4) and 38(8) of the NHRA.

From: sivest_PPP <sivest_ppp@sivest.co.za>
Sent: Monday, 10 February 2020 17:04
Cc: Stephan Jacobs <StephanJ@sivest.co.za>; Liandra Scott-Shaw <LiandraS@sivest.co.za>; 'Sheldon.vandrey@edf-re.co.za' <Sheldon.vandrey@edf-re.co.za>
Subject: 15324 Three (3) Solar PV Energy Facilities and Grid Infrastructures near Noupoort and Middelburg: DBAR Comment Period Starting

Dear Interested and/or Affected Party (I&AP),

BASIC ASSESSMENTS (BAs) FOR THE PROPOSED DEVELOPMENT OF THE THREE (3) GRID CONNECTION INFRASTRUCTURE DEVELOPMENTS (SUBSTATIONS AND POWER LINES) NEAR NOUPOORT AND MIDDELBURG IN THE NORTHERN AND EASTERN CAPE PROVINCES

- **Mooi Plaats Grid – (DEA Ref No: To be announced)**
- **Wonderheuvel Grid – (DEA Ref No: To be announced)**
- **Paarde Valley Grid – (DEA Ref No: To be announced)**

Please note that SiVEST SA (Pty) Ltd has been appointed as the independent Environmental Assessment Practitioner (EAP) to undertake the Basic Assessment (BA) processes for the above-mentioned proposed projects.

We would like to take this opportunity to inform you that, in accordance with the National Environmental Management Act, 1998 (Act No. 107 of 1998) (NEMA) (as amended), the Draft Basic Assessment Reports (DBARs) for the above-mentioned proposed projects will be available for public comment and review as from **Monday the 10th of February 2020 to Wednesday the 11th of March 2020** (end of business day). Should you wish to receive an electronic copy of the DBARs (on CD), please forward your request in writing to us. Comments can be submitted to:

Hlengiwe Ntuli
PO Box 2921, RIVONIA, 2128
Phone: (011) 798 0600
E-mail: sivest_ppp@sivest.co.za / hlengiwen@sivest.co.za / stephanj@sivest.co.za
Fax: (011) 803 7272

Hard copies of the DBARs can be reviewed at the following public places:

| VENUE | REPORT(S) | STREET ADDRESS | HOURS | CONTACT NO |
|---------------------------|-------------------------|----------------------------------------|----------------------------------------------------------------|-----------------|
| Noupoort Public Library | Mooi Plaats Grid DBAR | Shaw St, Noupoort, 5950 | Mondays - Fridays 10:00 - 13:00 13:45 - 16:30 | 049 843 1056 |
| | Wonderheuvel Grid DBAR | | | |
| Middelburg Public Library | Paarde Valley Grid DBAR | 47 Van Reenen Street, Middelburg, 5900 | Mondays - Fridays 09:00 - 16:30 | 049 802 1300 |
| | Wonderheuvel Grid DBAR | | | |

The reports as well as the accompanying appendices are also available on SiVEST's website: <http://www.sivest.co.za/>, click on 'Downloads', then browse to the folder '15324 Umsobomvu PV and Grid'. Please reference 'Mooi Plaats / Wonderheuvel / Paarde Valley Grid' in your correspondence, should your comments be project specific.

We would like to thank you in anticipation of your active and meaningful contribution to the BA and public participation processes.

Geagte Belangstellende en/of Geaffekteerde Party,

BASIESE EVALUERINGS (BEs) VIR DIE BEOOGDE ONTWIKKELING VAN DIE DRIE (3) NETWERKVERBINDINGSINFRASTRUKTUURONTWIKKELINGS (SUBSTASIES EN KRAGLYNE) NABY NOUPOORT EN MIDDELBURG IN DIE NOORD- EN OOS-KAAPPROVINSIES

- **MOOI PLAATS SUBSTASIES EN KRAGLYN – (DO-verw. No.: Moet nog aangekondig word)**
- **WONDERHEUVEL SUBSTASIES EN KRAGLYN – (DO-verw. No.: Moet nog aangekondig word)**
- **PAARDE VALLEY SUBSTASIES EN KRAGLYN – (DO-verw. No.: Moet nog aangekondig word)**

Ons stel u graag in kennis dat SiVEST SA (Edms) Bpk aangestel is as die onafhanklike Omgewingsevalueringspraktisyn (OEP) om die Basiese Evalueerings- (BE) prosesse vir die bogenoemde voorgestelde projekte te onderneem.

Ons wil graag van hierdie geleentheid gebruik maak om u in te lig dat ingevolge die Nasionale Wet op Omgewingsbestuur (NEMA) (Wet No. 107 van 1998) (soos gewysig), sal die Konsep Basiese Evaleeringsverslae (KBEVs) vir die bogenoemde voorgestelde projekte vanaf **Maandag 10 Februarie 2020** tot **Woensdag 11 Maart 2020** (teen sluitingstyd) beskikbaar wees vir openbare kommentaar en insae. As u elektroniese kopie van die KBEVs (op CD) wil ontvang, moet u dit asseblief skriftelik by ons versoek. Kommentaar kan soos volg ingedien word:

Hlengiwe Ntuli

Posbus 2921, RIVONIA, 2128

Foon: (011) 798 0600

E-pos: sivest_ppp@sivest.co.za / hlengiwen@sivest.co.za / stephanj@sivest.co.za

Faks: (011) 803 7272

Gedrukte kopie van die KBEVs kan by die volgende openbare plekke nagegaan word:

| PLEK | VERSLAG / VERSLAE | STRAATADRES | TYE | KONTAKNOMMERS |
|--------------------------------------|-----------------------------------------------------------------------------------------------|------------------------------------------|---------------------------------------------------------------------|---------------|
| Noupoort Publieke Biblioteek | Mooi Plaats Substasie en Kraglyn KBEV | Shawstraat, Noupoort, 5950 | Maandae - Vrydae 10:00 - 13:00 13:45 - 16:30 | 049 843 1056 |
| Middelburg Publieke Biblioteek | Wonderheuvel Substasie en Kraglyn KBEV Paarde Valley Substasie en Kraglyn KBEV | Van Reenenstraat 47, Middelburg, 5900 | Maandae - Vrydae 09:00 - 16:30 | 049 802 1300 |

Die verslae, sowel as die meegaande aanhangsels, is ook beskikbaar op SiVEST se webwerf: <http://www.sivest.co.za/>, klik op 'Downloads' en soek dan vir die legger '15324 Umsobomvu PV and Grid'. Verwys asseblief 'Mooi Plaats / Wonderheuvel / Paarde Valley Grid' in u korrespondensie, indien u kommentaar spesifiek op die projek is.

Ons dank u byvoorbaat vir u aktiewe en betekenisvolle bydrae tot die BE en Openbare Deelnameprosesse.

Kind Regards,

Stephan Jacobs (B.Sc. (Hons) Environmental Management and Analysis)

Environmental Consultant / Visual Specialist

SiVEST Environmental Division



SiVEST is a Level 3 BBBEE Contributor

D +27 11 798 0677 | **T** +27 011 798 0600 **E** stephanj@sivest.co.za | **W** www.sivest.co.za

Engineering Consulting | Project Management | Environmental Consulting | Town & Regional Planning | Management Systems Consulting
Durban | Johannesburg | Pretoria | Pietermaritzburg | Richards Bay | Port Louis (Mauritius)

Disclaimer

The information contained in this communication from the sender is confidential. It is intended solely for use by the recipient and others authorized to receive it. If you are not the recipient, you are hereby notified that any disclosure, copying, distribution or taking action in relation of the contents of this information is strictly prohibited and may be unlawful.

This email has been scanned for viruses and malware, and automatically archived by **Mimecast SA (Pty) Ltd**, an innovator in Software as a Service (SaaS) for business. **Mimecast Unified Email Management ??? (UEM)** offers email continuity, security, archiving and compliance with all current legislation. To find out more, [contact Mimecast](#).

Natasha Higgitt

Heritage Officer: Archaeology, Palaeontology and Meteorites Unit

South African Heritage Resources Agency

- A nation united through heritage -

T: +27 21 462 4502/ 8660 | **C:** +27 82 507 0378 | **F:** +27 21 462 4509

E: nhiggitt@sahra.org.za | 111 Harrington Street | Cape Town |

www.sahra.org.za

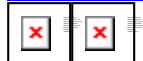

sivest_PPP

From: Natasha Higgitt <nhiggitt@sahra.org.za>
Sent: 17 February 2020 12:06 PM
To: sivest_PPP
Cc: Stephan Jacobs; Liandra Scott-Shaw; 'Sheldon.vandrey@edf-re.co.za'; Nonyameko Mlungwana; Leomile Mofutsanyana
Subject: RE: 15324 Three (3) Solar PV Energy Facilities and Grid Infrastructures near Noupoort and Middelburg: DBAR Comment Period Starting

Good afternoon,

Thank you for the notification.

Nonyameko/Leomile, please can you assist Sivest with their applications as per the email below?

Thank you.

From: sivest_PPP <sivest_ppp@sivest.co.za>
Sent: Monday, 17 February 2020 11:52
To: Natasha Higgitt <nhiggitt@sahra.org.za>
Cc: Stephan Jacobs <StephanJ@sivest.co.za>; Liandra Scott-Shaw <LiandraS@sivest.co.za>; 'Sheldon.vandrey@edf-re.co.za' <Sheldon.vandrey@edf-re.co.za>
Subject: RE: 15324 Three (3) Solar PV Energy Facilities and Grid Infrastructures near Noupoort and Middelburg: DBAR Comment Period Starting
Importance: High

Good Day Natasha,

We have been trying to create cases on your website with no success from last week and even this morning.

Please see error below:

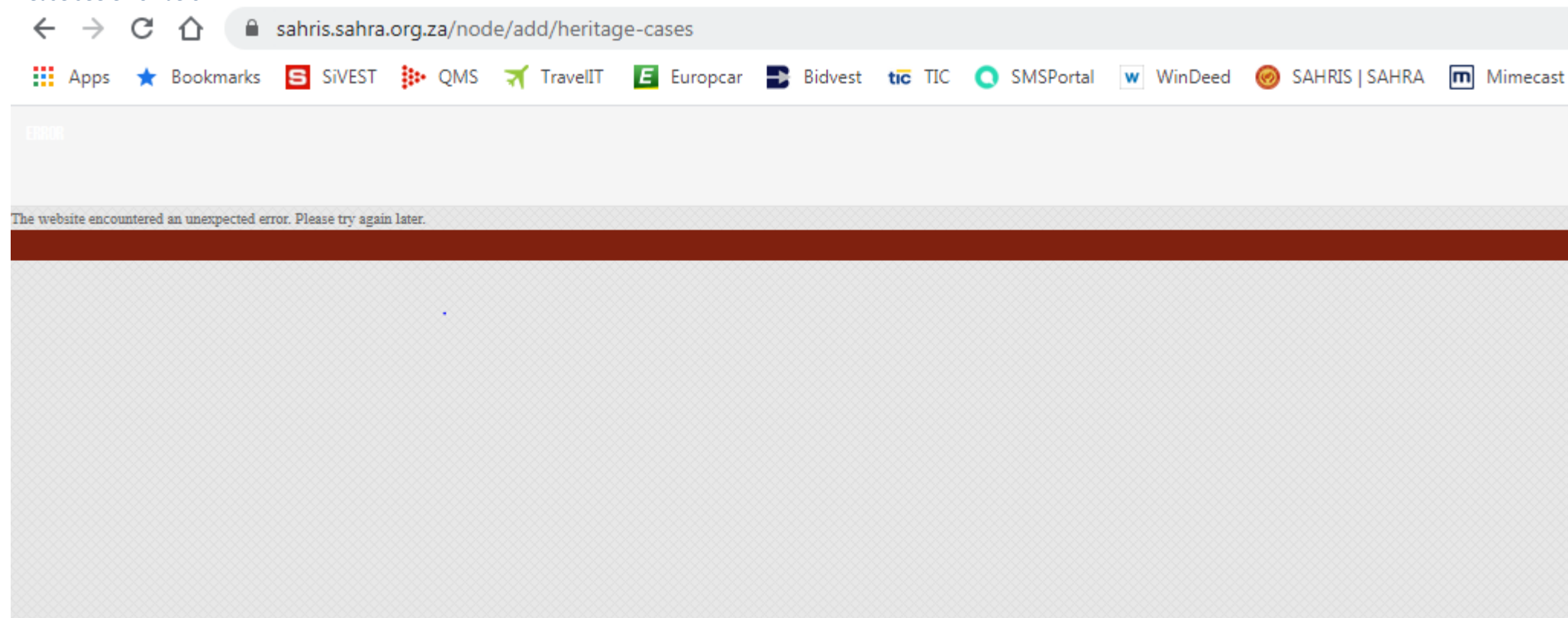

From: Natasha Higgitt [mailto:nhiggitt@sahra.org.za]
Sent: 11 February 2020 08:03 AM
To: sivest_PPP <sivest_ppp@sivest.co.za>
Cc: Stephan Jacobs <StephanJ@sivest.co.za>; Liandra Scott-Shaw <LiandraS@sivest.co.za>; 'Sheldon.vandrey@edf-re.co.za' <Sheldon.vandrey@edf-re.co.za>
Subject: RE: 15324 Three (3) Solar PV Energy Facilities and Grid Infrastructures near Noupoort and Middelburg: DBAR Comment Period Starting

Good morning,

Please note that all development applications are processed via our online portal, the South African Heritage Resources Information System (SAHRIS) found at the following link: <http://sahra.org.za/sahrisk/>. We do not accept emailed, posted, hardcopy, faxed, website links or DropBox links as official submissions.

Please create an application on SAHRIS and upload all documents pertaining to the Environmental Authorisation Application Process. As per section 38(8) of the National Heritage Resources Act, Act 25 of 1999 (NHRA), an assessment of heritage resources must form part of the process and the assessment must comply with section 38(3) of the NHRA.

Once all documents including all appendices are uploaded to the case application, please ensure that the status of the case is changed from DRAFT to SUBMITTED. Please ensure that all documents produced as part of the EA process are submitted as part of the application, and are submitted to SAHRA at the beginning of the Public Review periods. Once all these documents have been uploaded, I will be able to issue an informed comment as per section 38(4) and 38(8) of the NHRA.

From: sivest_PPP <sivest_ppp@sivest.co.za>
Sent: Monday, 10 February 2020 17:04
Cc: Stephan Jacobs <StephanJ@sivest.co.za>; Liandra Scott-Shaw <LiandraS@sivest.co.za>; 'Sheldon.vandrey@edf-re.co.za' <Sheldon.vandrey@edf-re.co.za>
Subject: 15324 Three (3) Solar PV Energy Facilities and Grid Infrastructures near Noupoort and Middelburg: DBAR Comment Period Starting

Dear Interested and/or Affected Party (I&AP),

BASIC ASSESSMENTS (BAs) FOR THE PROPOSED DEVELOPMENT OF THE THREE (3) GRID CONNECTION INFRASTRUCTURE DEVELOPMENTS (SUBSTATIONS AND POWER LINES) NEAR NOUPOORT AND MIDDELBURG IN THE NORTHERN AND EASTERN CAPE PROVINCES

- **Mooi Plaats Grid – (DEA Ref No: To be announced)**
- **Wonderheuvel Grid – (DEA Ref No: To be announced)**
- **Paarde Valley Grid – (DEA Ref No: To be announced)**

Please note that SiVEST SA (Pty) Ltd has been appointed as the independent Environmental Assessment Practitioner (EAP) to undertake the Basic Assessment (BA) processes for the above-mentioned proposed projects.

We would like to take this opportunity to inform you that, in accordance with the National Environmental Management Act, 1998 (Act No. 107 of 1998) (NEMA) (as amended), the Draft Basic Assessment Reports (DBARs) for the above-mentioned proposed projects will be available for public comment and review as from **Monday the 10th of February 2020 to Wednesday the 11th of March 2020** (end of business day). Should you wish to receive an electronic copy of the DBARs (on CD), please forward your request in writing to us. Comments can be submitted to:

Hlengiwe Ntuli
 PO Box 2921, RIVONIA, 2128
 Phone: (011) 798 0600
 E-mail: sivest_ppp@sivest.co.za / hlengiwen@sivest.co.za / stephanj@sivest.co.za
 Fax: (011) 803 7272

Hard copies of the DBARs can be reviewed at the following public places:

| VENUE | REPORT(S) | STREET ADDRESS | HOURS | CONTACT NO |
|---------------------------|-------------------------|----------------------------------------|------------------------------------------------------------|--------------|
| Noupoort Public Library | Mooi Plaats Grid DBAR | Shaw St, Noupoort, 5950 | Mondays - Fridays 10:00 - 13:00 13:45 - 16:30 | 049 843 1056 |
| | Wonderheuvel Grid DBAR | | Mondays - Fridays 09:00 - 16:30 | |
| Middelburg Public Library | Paarde Valley Grid DBAR | 47 Van Reenen Street, Middelburg, 5900 | Mondays - Fridays 09:00 - 16:30 | 049 802 1300 |
| | Paarde Valley Grid DBAR | | | |

The reports as well as the accompanying appendices are also available on SiVEST's website: <http://www.sivest.co.za/>, click on 'Downloads', then browse to the folder '15324 Umsobomvu PV and Grid'. Please reference 'Mooi Plaats / Wonderheuvel / Paarde Valley Grid' in your correspondence, should your comments be project specific.

We would like to thank you in anticipation of your active and meaningful contribution to the BA and public participation processes.

Geagte Belangstellende en/of Geaffekteerde Party,

BASIESE EVALUERINGS (BEs) VIR DIE BEOOGDE ONTWIKKELING VAN DIE DRIE (3) NETWERKVERBINDINGSINFRASTRUKTUURONTWIKKELINGS (SUBSTASIES EN KRAGLYNE) NABY NOUPOORT EN MIDDELBURG IN DIE NOORD- EN OOS-KAAPROVINSIES

- **MOOI PLAATS SUBSTASIES EN KRAGLYN – (DO-verw. No.: Moet nog aangekondig word)**
- **WONDERHEUVEL SUBSTASIES EN KRAGLYN – (DO-verw. No.: Moet nog aangekondig word)**
- **PAARDE VALLEY SUBSTASIES EN KRAGLYN – (DO-verw. No.: Moet nog aangekondig word)**

Ons stel u graag in kennis dat SiVEST SA (Edms) Bpk aangestel is as die onafhanklike Omgewingsevalueringspraktisyn (OEP) om die Basiese Evalueerings- (BE) prosesse vir die bogenoemde voorgestelde projekte te onderneem.

Ons wil graag van hierdie geleentheid gebruik maak om u in te lig dat ingevolge die Nasionale Wet op Omgewingsbestuur (NEMA) (Wet No. 107 van 1998) (soos gewysig), sal die Konsep Basiese Evalueeringsverslae (KBEVs) vir die bogenoemde voorgestelde projekte vanaf **Maandag 10 Februarie 2020 tot Woensdag 11 Maart 2020** (teen sluitingstyd) beskikbaar wees vir openbare kommentaar en insae. As u elektroniese kopie van die KBEVs (op CD) wil ontvang, moet u dit asseblief skriftelik by ons versoek. Kommentaar kan soos volg ingedien word:

Hlengiwe Ntuli
 Posbus 2921, RIVONIA, 2128
 Foon: (011) 798 0600
 E-pos: sivest_ppp@sivest.co.za / hlengiwen@sivest.co.za / stephanj@sivest.co.za
 Faks: (011) 803 7272

Gedrukte kopie van die KBEVs kan by die volgende openbare plekke nagegaan word:

| PLEK | VERSLAG / VERSLAE | STRAATADRES | TYE | KONTAKNOMMERS |
|--------------------------------|-----------------------------------------|---------------------------------------|-----------------------------------------------------------|---------------|
| Noupoort Publieke Biblioteek | Mooi Plaats Substasie en Kraglyn KBEV | Shawstraat, Noupoort, 5950 | Maandae - Vrydae 10:00 - 13:00 13:45 - 16:30 | 049 843 1056 |
| | Wonderheuvel Substasie en Kraglyn KBEV | | Maandae - Vrydae 09:00 - 16:30 | |
| Middelburg Publieke Biblioteek | Paarde Valley Substasie en Kraglyn KBEV | Van Reenenstraat 47, Middelburg, 5900 | Maandae - Vrydae 09:00 - 16:30 | 049 802 1300 |

Die verslae, sowel as die meegaande aanhangsels, is ook beskikbaar op SiVEST se webwerf: <http://www.sivest.co.za/>, klik op 'Downloads' en soek dan vir die legger '15324 Umsobomvu PV and Grid'. Verwys asseblief 'Mooi Plaats / Wonderheuvel / Paarde Valley Grid' in u korrespondensie, indien u kommentaar spesifiek op die projek is.

Ons dank u byvoorbaat vir u aktiewe en betekenisvolle bydrae tot die BE en Openbare Deelnameprosesse.

Kind Regards,

Stephan Jacobs (B.Sc. (Hons) Environmental Management and Analysis)

Environmental Consultant / Visual Specialist

SiVEST Environmental Division

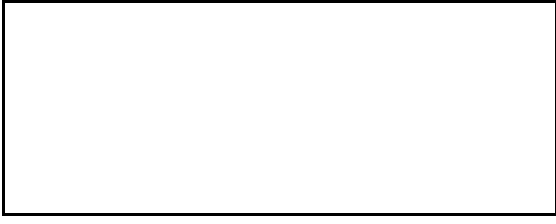

SiVEST is a Level 3 BBBEE Contributor

D +27 11 798 0677 | **T** +27 011 798 0600 **E** stephanj@sivest.co.za | **W** www.sivest.co.za

Engineering Consulting | Project Management | Environmental Consulting | Town & Regional Planning | Management Systems Consulting
Durban | Johannesburg | Pretoria | Pietermaritzburg | Richards Bay | Port Louis (Mauritius)

Disclaimer

The information contained in this communication from the sender is confidential. It is intended solely for use by the recipient and others authorized to receive it. If you are not the recipient, you are hereby notified that any disclosure, copying, distribution or taking action in relation of the contents of this information is strictly prohibited and may be unlawful.

This email has been scanned for viruses and malware, and automatically archived by **Mimecast SA (Pty) Ltd**, an innovator in Software as a Service (SaaS) for business. **Mimecast Unified Email Management ??? (UEM)** offers email continuity, security, archiving and compliance with all current legislation. To find out more, [contact Mimecast](#).

Natasha Higgitt

Heritage Officer: Archaeology, Palaeontology and Meteorites Unit

South African Heritage Resources Agency

- A nation united through heritage -

T: +27 21 462 4502/ 8660 | **C:** +27 82 507 0378 | **F:** +27 21 462 4509

E: nhiggitt@sahra.org.za | 111 Harrington Street | Cape Town |

www.sahra.org.za

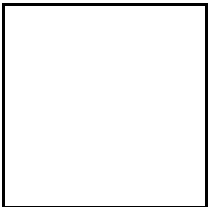

Disclaimer

The information contained in this communication from the sender is confidential. It is intended solely for use by the recipient and others authorized to receive it. If you are not the recipient, you are hereby notified that any disclosure, copying, distribution or taking action in relation of the contents of this information is strictly prohibited and may be unlawful.

This email has been scanned for viruses and malware, and automatically archived by **Mimecast SA (Pty) Ltd**, an innovator in Software as a Service (SaaS) for business. **Mimecast Unified Email Management ??? (UEM)** offers email continuity, security, archiving and compliance with all current legislation. To find out more, [contact Mimecast](#).

Natasha Higgitt

Heritage Officer: Archaeology, Palaeontology and Meteorites Unit

South African Heritage Resources Agency

- A nation united through heritage -

T: +27 21 462 4502/ 8660 | **C:** +27 82 507 0378 | **F:** +27 21 462 4509

E: nhiggitt@sahra.org.za | 111 Harrington Street | Cape Town |

www.sahra.org.za

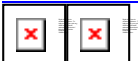

sivest_PPP

From: Nonyameko Mlungwana <nmlungwana@sahra.org.za>
Sent: 17 February 2020 12:33 PM
To: Natasha Higgitt; sivest_PPP
Cc: Stephan Jacobs; Liandra Scott-Shaw; 'Sheldon.vandrey@edf-re.co.za'; Leomile Mofutsanyana
Subject: RE: 15324 Three (3) Solar PV Energy Facilities and Grid Infrastructures near Noupoot and Middelburg: DBAR Comment Period Starting

Good day,

Please create a draft case and save it without uploading the documents, then edit the draft case to upload the pdf documents. In most cases it crashes when you create the case and upload the documents at the same time. If it still crashes let us know.

Kind regards

From: Natasha Higgitt <nhiggitt@sahra.org.za>
Sent: 17 February 2020 12:06 PM
To: sivest_PPP <sivest_ppp@sivest.co.za>
Cc: Stephan Jacobs <StephanJ@sivest.co.za>; Liandra Scott-Shaw <LiandraS@sivest.co.za>; 'Sheldon.vandrey@edf-re.co.za' <Sheldon.vandrey@edf-re.co.za>; Nonyameko Mlungwana <nmlungwana@sahra.org.za>; Leomile Mofutsanyana <lmofutsanyana@sahra.org.za>
Subject: RE: 15324 Three (3) Solar PV Energy Facilities and Grid Infrastructures near Noupoot and Middelburg: DBAR Comment Period Starting

Good afternoon,

Thank you for the notification.

Nonyameko/Leomile, please can you assist Sivest with their applications as per the email below?

Thank you.

From: sivest_PPP <sivest_ppp@sivest.co.za>
Sent: Monday, 17 February 2020 11:52
To: Natasha Higgitt <nhiggitt@sahra.org.za>
Cc: Stephan Jacobs <StephanJ@sivest.co.za>; Liandra Scott-Shaw <LiandraS@sivest.co.za>; 'Sheldon.vandrey@edf-re.co.za' <Sheldon.vandrey@edf-re.co.za>
Subject: RE: 15324 Three (3) Solar PV Energy Facilities and Grid Infrastructures near Noupoot and Middelburg: DBAR Comment Period Starting
Importance: High

Good Day Natasha,

We have been trying to create cases on your website with no success from last week and even this morning.

Please see error below:

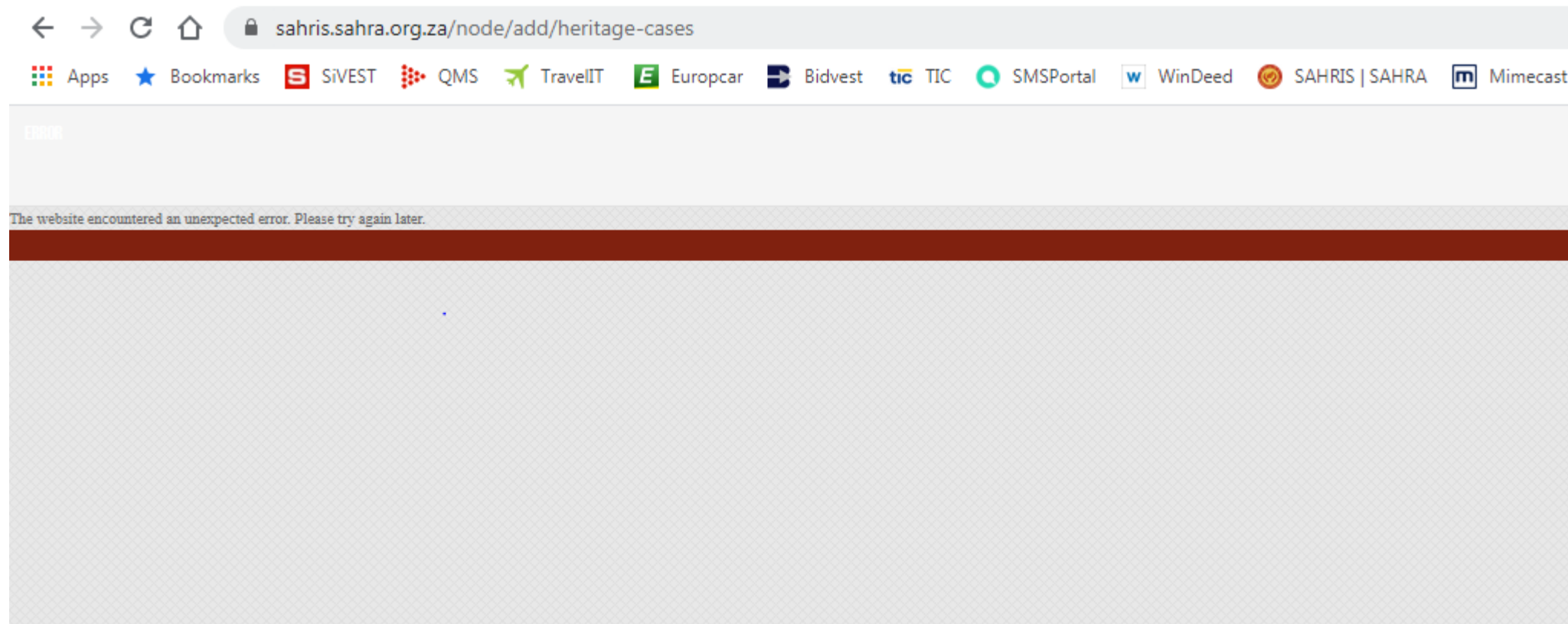

From: Natasha Higgitt [<mailto:nhiggitt@sahra.org.za>]
Sent: 11 February 2020 08:03 AM
To: sivest_PPP <sivest_ppp@sivest.co.za>
Cc: Stephan Jacobs <StephanJ@sivest.co.za>; Liandra Scott-Shaw <LiandraS@sivest.co.za>; 'Sheldon.vandrey@edf-re.co.za' <Sheldon.vandrey@edf-re.co.za>
Subject: RE: 15324 Three (3) Solar PV Energy Facilities and Grid Infrastructures near Noupoot and Middelburg: DBAR Comment Period Starting

Good morning,

Please note that all development applications are processed via our online portal, the South African Heritage Resources Information System (SAHRIS) found at the following link: <http://sahra.org.za/sahriss/>. We do not accept emailed, posted, hardcopy, faxed, website links or DropBox links as official submissions.

Please create an application on SAHRIS and upload all documents pertaining to the Environmental Authorisation Application Process. As per section 38(8) of the National Heritage Resources Act, Act 25 of 1999 (NHRA), an assessment of heritage resources must form part of the process and the assessment must comply with section 38(3) of the NHRA.

Once all documents including all appendices are uploaded to the case application, please ensure that the status of the case is changed from DRAFT to SUBMITTED. Please ensure that all documents produced as part of the EA process are submitted as part of the application, and are submitted to SAHRA at the beginning of the Public Review periods. Once all these documents have been uploaded, I will be able to issue an informed comment as per section 38(4) and 38(8) of the NHRA.

From: sivest_PPP <sivest_ppp@sivest.co.za>

Sent: Monday, 10 February 2020 17:04

Cc: Stephan Jacobs <StephanJ@sivest.co.za>; Liandra Scott-Shaw <LiandraS@sivest.co.za>; 'Sheldon.vandrey@edf-re.co.za' <Sheldon.vandrey@edf-re.co.za>

Subject: 15324 Three (3) Solar PV Energy Facilities and Grid Infrastructures near Noupoort and Middelburg: DBAR Comment Period Starting

Dear Interested and/or Affected Party (I&AP),

BASIC ASSESSMENTS (BAs) FOR THE PROPOSED DEVELOPMENT OF THE THREE (3) GRID CONNECTION INFRASTRUCTURE DEVELOPMENTS (SUBSTATIONS AND POWER LINES) NEAR NOUPOORT AND MIDDELBURG IN THE NORTHERN AND EASTERN CAPE PROVINCES

- **Mooi Plaats Grid – (DEA Ref No: To be announced)**
- **Wonderheuvel Grid – (DEA Ref No: To be announced)**
- **Paarde Valley Grid – (DEA Ref No: To be announced)**

Please note that SiVEST SA (Pty) Ltd has been appointed as the independent Environmental Assessment Practitioner (EAP) to undertake the Basic Assessment (BA) processes for the above-mentioned proposed projects.

We would like to take this opportunity to inform you that, in accordance with the National Environmental Management Act, 1998 (Act No. 107 of 1998) (NEMA) (as amended), the Draft Basic Assessment Reports (DBARs) for the above-mentioned proposed projects will be available for public comment and review as from **Monday the 10th of February 2020 to Wednesday the 11th of March 2020** (end of business day). Should you wish to receive an electronic copy of the DBARs (on CD), please forward your request in writing to us. Comments can be submitted to:

Hlengiwe Ntuli

PO Box 2921, RIVONIA, 2128

Phone: (011) 798 0600

E-mail: sivest_ppp@sivest.co.za / hlengiwen@sivest.co.za / stephanj@sivest.co.za

Fax: (011) 803 7272

Hard copies of the DBARs can be reviewed at the following public places:

| VENUE | REPORT(S) | STREET ADDRESS | HOURS | CONTACT NO |
|---------------------------|-------------------------|-------------------------------------------|----------------------------------------------------------------|-----------------|
| Noupoort Public Library | Mooi Plaats Grid DBAR | Shaw St, Noupoort, 5950 | Mondays - Fridays 10:00 - 13:00 13:45 - 16:30 | 049 843 1056 |
| | Wonderheuvel Grid DBAR | | Mondays - Fridays 09:00 - 16:30 | 049 802 1300 |
| Middelburg Public Library | Paarde Valley Grid DBAR | 47 Van Reenen Street, Middelburg, 5900 | | |
| | | | | |

The reports as well as the accompanying appendices are also available on SiVEST's website: <http://www.sivest.co.za/>, click on 'Downloads', then browse to the folder '15324 Umsobomvu PV and Grid'. Please reference 'Mooi Plaats / Wonderheuvel / Paarde Valley Grid' in your correspondence, should your comments be project specific.

We would like to thank you in anticipation of your active and meaningful contribution to the BA and public participation processes.

Geagte Belangstellende en/of Geaffekteerde Party,

BASIESE EVALUERINGS (BEs) VIR DIE BEOOGDE ONTWIKKELING VAN DIE DRIE (3) NETWERKVERBINDINGSINFRASTRUKTUURONTWIKKELINGS (SUBSTASIES EN KRAGLYNE) NABY NOUPOORT EN MIDDELBURG IN DIE NOORD- EN OOS-KAAPPROVINSIES

- **MOOI PLAATS SUBSTASIES EN KRAGLYN – (DO-verw. No.: Moet nog aangekondig word)**
- **WONDERHEUVEL SUBSTASIES EN KRAGLYN – (DO-verw. No.: Moet nog aangekondig word)**
- **PAARDE VALLEY SUBSTASIES EN KRAGLYN – (DO-verw. No.: Moet nog aangekondig word)**

Ons stel u graag in kennis dat SiVEST SA (Edms) Bpk aangestel is as die onafhanklike Omgewingsevalueringspraktisyn (OEP) om die Basiese Evalueerings- (BE) prosesse vir die bogenoemde voorgestelde projekte te onderneem.

Ons wil graag van hierdie geleentheid gebruik maak om u in te lig dat ingevolge die Nasionale Wet op Omgewingsbestuur (NEMA) (Wet No. 107 van 1998) (soos gewysig), sal die Konsep Basiese Evalueeringsverslae (KBEVs) vir die bogenoemde voorgestelde projekte vanaf **Maandag 10 Februarie 2020 tot Woensdag 11 Maart 2020** (teen sluitingstyd) beskikbaar wees vir openbare kommentaar en insae. As u elektroniese kopie van die KBEVs (op CD) wil ontvang, moet u dit asseblief skriftelik by ons versoek. Kommentaar kan soos volg ingedien word:

Hlengiwe Ntuli

Posbus 2921, RIVONIA, 2128

Foon: (011) 798 0600

E-pos: sivest_ppp@sivest.co.za / hlengiwen@sivest.co.za / stephanj@sivest.co.za

Faks: (011) 803 7272

Gedrukte kopie van die KBEVs kan by die volgende openbare plekke nagegaan word:

PLEK VERSLAG / VERSLAE STRAATADRES TYE KONTAKNOMMERS

| | | | | |
|--------------------------------------|---------------------------------------------------------------------------------------------------|------------------------------------------|---------------------------------------------------------------------|--------------|
| Noupoort Publieke Biblioteek | Mooi Plaats Substasie en Kraglyn KBEV | Shawstraat, Noupoort, 5950 | Maandae - Vrydae 10:00 - 13:00 13:45 - 16:30 | 049 843 1056 |
| Middelburg Publieke Biblioteek | Wonderheuvel Substasie en Kraglyn KBEV Paarde Valley Substasie en Kraglyn KBEV | Van Reenenstraat 47, Middelburg, 5900 | Maandae - Vrydae 09:00 - 16:30 | 049 802 1300 |

Die verslae, sowel as die meegaande aanhangsels, is ook beskikbaar op SiVEST se webwerf: <http://www.sivest.co.za/>, klik op 'Downloads' en soek dan vir die legger '15324 Umsobomvu PV and Grid'. Verwys asseblief 'Mooi Plaats / Wonderheuvel / Paarde Valley Grid' in u korrespondensie, indien u kommentaar spesifiek op die projek is.

Ons dank u byvoorbaat vir u aktiewe en betekenisvolle bydrae tot die BE en Openbare Deelnameprosesse.

Kind Regards,

Stephan Jacobs (B.Sc. (Hons) Environmental Management and Analysis)
Environmental Consultant / Visual Specialist
SiVEST Environmental Division

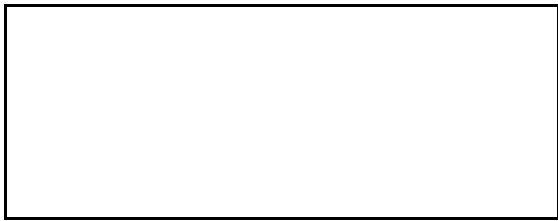

SiVEST is a Level 3 BBBEE Contributor

D +27 11 798 0677 | **T** +27 011 798 0600 **E** stephanj@sivest.co.za | **W** www.sivest.co.za
Engineering Consulting | Project Management | Environmental Consulting | Town & Regional Planning | Management Systems Consulting
Durban | Johannesburg | Pretoria | Pietermaritzburg | Richards Bay | Port Louis (Mauritius)

Disclaimer

The information contained in this communication from the sender is confidential. It is intended solely for use by the recipient and others authorized to receive it. If you are not the recipient, you are hereby notified that any disclosure, copying, distribution or taking action in relation of the contents of this information is strictly prohibited and may be unlawful.

This email has been scanned for viruses and malware, and automatically archived by **Mimecast SA (Pty) Ltd**, an innovator in Software as a Service (SaaS) for business. **Mimecast Unified Email Management ??? (UEM)** offers email continuity, security, archiving and compliance with all current legislation. To find out more, [contact Mimecast](#).

Natasha Higgitt

Heritage Officer: Archaeology, Palaeontology and Meteorites Unit

South African Heritage Resources Agency
- A nation united through heritage -

T: +27 21 462 4502/ 8660 | **C:** +27 82 507 0378 | **F:** +27 21 462 4509
E: nhiggitt@sahra.org.za | 111 Harrington Street | Cape Town |

www.sahra.org.za

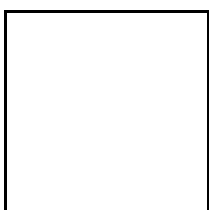

Disclaimer

Stephan Jacobs

From: sahrisadmin@sahra.org.za on behalf of SAHRA <sahrisadmin@sahra.org.za>
Sent: Thursday, 27 February 2020 10:38 AM
To: Hlengiwe Ntuli
Subject: New private message from SAHRIS: SAHRIS Case ID 14884 and 14885

Hi andrea.gibb,

This is an automatic reminder from the site SAHRA. You have received a new private message from natasha.higgitt.

To read your message on SAHRIS,
First LOGIN TO SAHRIS
then, follow this link:

<https://sahris.sahra.org.za/messages/view/25500>

Alternatively, login to SAHRIS and navigate to www.sahra.org.za/messages

The body of your message reads:

Good morning,

Please note that the location of the developments for SAHRIS Case ID 14884 and 14885 have not been mapped. Please upload a kml file to the third page of each application as soon as possible. I cannot issue any comments on an incomplete application.

Regards,
Natasha Higgitt

If you don't want to receive these emails again, change your preferences here:

<https://sahris.sahra.org.za/user/2486/edit>

Please do not reply to this automated message as it is generated by the system account.

Hlengiwe Ntuli

From: Natasha Higgitt <nhiggitt@sahra.org.za>
Sent: Friday, February 28, 2020 8:06 AM
To: Stephan Jacobs
Cc: Liandra Scott-Shaw; Hlengiwe Ntuli
Subject: RE: Paarde Valley Substations and Power Line near Noupoort and Middelburg in the Northern and Eastern Cape Provinces (): SAHRIS Case Created

Good morning,

Thank you for the notification. I have assigned myself to Paarde Valley and I have completed the comments for all three cases. They have been sent for the usual internal review and I will inform you once the comments have been issued.

Kind regards,

From: Stephan Jacobs <StephanJ@sivest.co.za>
Sent: Thursday, 27 February 2020 12:31
To: Natasha Higgitt <nhiggitt@sahra.org.za>
Cc: Liandra Scott-Shaw <LiandraS@sivest.co.za>; Hlengiwe Ntuli <HlengiweN@sivest.co.za>
Subject: Paarde Valley Substations and Power Line near Noupoort and Middelburg in the Northern and Eastern Cape Provinces (): SAHRIS Case Created
Importance: High

Good Afternoon Natasha,

I trust you are well.

Please be advised that SIVEST created case applications on SAHRIS for the Mooi Plaats (Case ID **14884**) and Wonderheuveld (Case ID **14885**) Substation and Power Line projects (i.e. the grid projects), however, a case application was never created for the Paarde Valley grid project. Apologies for this. The Paarde valley grid project crosses the Eastern and Northern Cape Provincial boundaries and thus I believe SAHRA will need to comment on the project as SAHRA comments on developments in the Northern Cape Province.

Please note that a case application has now been created for the Paarde valley Substation and Power Line project (i.e. Paarde valley Grid) and the following Case ID has been allocated: **14944**.

Please note that the ECPHRA are also being consulted in order to provide comments on the Wonderheuveld and Paarde Valley Grid projects, as they cross into the Eastern Cape Province.

I trust you will find everything is in order.

Apologies for any inconvenience this might have caused.

Please do not hesitate to contact us should there be any issues or should you require any further information.

Kind Regards,

Stephan Jacobs *(B.Sc. (Hons) Environmental Management and Analysis)*
Environmental Consultant / Visual Specialist
SIVEST Environmental Division



SIVEST is a Level 3 BBBEE Contributor

D +27 11 798 0677 | **T** +27 011 798 0600 | **M** +27 72 737 2114 **E** stephanj@sivest.co.za | **W** www.sivest.co.za

Engineering Consulting | Project Management | Environmental Consulting | Town & Regional Planning | Management Systems Consulting

Durban | Johannesburg | Pretoria | Pietermaritzburg | Richards Bay | Port Louis (Mauritius)

Disclaimer

The information contained in this communication from the sender is confidential. It is intended solely for use by the recipient and others authorized to receive it. If you are not the recipient, you are hereby notified that any disclosure, copying, distribution or taking action in relation of the contents of this information is strictly prohibited and may be unlawful.

This email has been scanned for viruses and malware, and automatically archived by **Mimecast SA (Pty) Ltd**, an innovator in Software as a Service (SaaS) for business. **Mimecast Unified Email Management ??? (UEM)** offers email continuity, security, archiving and compliance with all current legislation. To find out more, [contact Mimecast](#).

Natasha Higgitt

Heritage Officer: Archaeology, Palaeontology and Meteorites Unit

South African Heritage Resources Agency

- A nation united through heritage -

T: +27 21 462 4502/ 8660 | **C:** +27 82 507 0378 | **F:** +27 21 462 4509

E: nhiggitt@sahra.org.za | 111 Harrington Street | Cape Town |

www.sahra.org.za



an agency of the
Department of Arts and Culture

OUR VALUES: *Accountability, Teamwork & co-operation, Respect, Transparency, Service Excellency, Integrity & Ethics, Professionalism, Accessibility, Communication & Trust.*

sivest_PPP

From: Ontvangs <ontvangs@agrink.co.za>
Sent: 03 March 2020 05:04 PM
To: Noupoot LU : SP van der Walt
Cc: sivest_PPP
Subject: FW: 15324 Three (3) Solar PV Energy Facilities and Grid Infrastructures near Noupoot and Middelburg: DBAR Comment Period Ending

Importance: High

SP

Vind asseblief hierby dokumentasie vir jou kennisname en verdere hantering indien nodig.

Vriendelike groete

Lucelle van Niekerk

ONTVANGS : AGRI NOORD-KAAP

E-pos : ontvangs@agrink.co.za

Tel : (053) 83 29595

Faks : (053) 83 27126



From: sivest_PPP [mailto:sivest_ppp@sivest.co.za]
Sent: Tuesday, March 3, 2020 4:28 PM
Cc: Stephan Jacobs <StephanJ@sivest.co.za>; Liandra Scott-Shaw <LiandraS@sivest.co.za>; 'Sheldon.vandrey@edf-re.co.za' <Sheldon.vandrey@edf-re.co.za>
Subject: RE: 15324 Three (3) Solar PV Energy Facilities and Grid Infrastructures near Noupoot and Middelburg: DBAR Comment Period Ending
Importance: High

Dear Interested and/or Affected Party (I&AP) / Stakeholder,

BASIC ASSESSMENTS (BAs) FOR THE PROPOSED DEVELOPMENT OF THE THREE (3) GRID CONNECTION INFRASTRUCTURE DEVELOPMENTS (SUBSTATIONS AND POWER LINES) NEAR NOUPOORT AND MIDDELBURG IN THE NORTHERN AND EASTERN CAPE PROVINCES

- Mooi Plaats Grid – (DEA Ref No: To be announced)
- Wonderheuvel Grid – (DEA Ref No: To be announced)
- Paarde Valley Grid – (DEA Ref No: To be announced)

Please note that the Draft Basic Assessment Reports (DBARs) for the above-mentioned projects were made available for public review and comment from **Monday the 10th of February 2020 to Wednesday the 11th of March 2020** (end of business day). The review and comment periods for the above-mentioned projects therefore end next week on **Wednesday the 11th of March 2020** (end of business day).

SiVEST therefore wish to remind you to submit comments for the above-mentioned projects (where required). If possible, please submit all comments before or by **Wednesday the 11th of March 2020** (end of business day).

Should you have any comments, please feel free to contact the public participation office at the details below:

SiVEST Environmental
PO Box 2921, RIVONIA, 2128
Phone: (011) 798 0600
E-mail: hlangiwen@sivest.co.za / sivest_ppp@sivest.co.za
Fax: (011) 803 7272

We would like to thank you in anticipation of your active and meaningful contribution to the BA and public participation process.

Kind Regards,
Hlangiwe Ntuli
Projects Secretary and PPP Administrator
SiVEST



SiVEST is a Level 3 BBBEE Contributor

D +27 11 798 0690 | T +27 11 798 0600 | E HlangiweN@sivest.co.za | W www.sivest.co.za
Engineering Consulting | Project Management | Environmental Consulting | Town & Regional Planning | Management Systems Consulting
Durban | Johannesburg | Pretoria | Pietermaritzburg | Richards Bay | Port Louis (Mauritius)

From: sivest_PPP
Sent: 10 February 2020 05:04 PM
Cc: Stephan Jacobs <StephanJ@sivest.co.za>; Liandra Scott-Shaw <LiandraS@sivest.co.za>; 'Sheldon.vandrey@edf-re.co.za' <Sheldon.vandrey@edf-re.co.za>
Subject: 15324 Three (3) Solar PV Energy Facilities and Grid Infrastructures near Noupoort and Middelburg: DBAR Comment Period Starting

Dear Interested and/or Affected Party (I&AP),

BASIC ASSESSMENTS (BAs) FOR THE PROPOSED DEVELOPMENT OF THE THREE (3) GRID CONNECTION INFRASTRUCTURE DEVELOPMENTS (SUBSTATIONS AND POWER LINES) NEAR NOUPOORT AND MIDDELBURG IN THE NORTHERN AND EASTERN CAPE PROVINCES

- **Mooi Plaats Grid – (DEA Ref No: To be announced)**
- **Wonderheuvel Grid – (DEA Ref No: To be announced)**
- **Paarde Valley Grid – (DEA Ref No: To be announced)**

Please note that SiVEST SA (Pty) Ltd has been appointed as the independent Environmental Assessment Practitioner (EAP) to undertake the Basic Assessment (BA) processes for the above-mentioned proposed projects.

We would like to take this opportunity to inform you that, in accordance with the National Environmental Management Act, 1998 (Act No. 107 of 1998) (NEMA) (as amended), the Draft Basic Assessment Reports (DBARs) for the above-mentioned proposed projects will be available for public comment and review as from **Monday the 10th of February 2020 to Wednesday the 11th of March 2020** (end of business day). Should you wish to receive an electronic copy of the DBARs (on CD), please forward your request in writing to us. Comments can be submitted to:

Hlengiwe Ntuli
 PO Box 2921, RIVONIA, 2128
 Phone: (011) 798 0600
 E-mail: sivest_ppp@sivest.co.za / hlengiwen@sivest.co.za / stephanj@sivest.co.za
 Fax: (011) 803 7272

Hard copies of the DBARs can be reviewed at the following public places:

| VENUE | REPORT(S) | STREET ADDRESS | HOURS | CONTACT NO |
|---------------------------|---------------------------------------------------|----------------------------------------|------------------------------------------------------------|--------------|
| Noupoort Public Library | Mooi Plaats Grid DBAR | Shaw St, Noupoort, 5950 | Mondays - Fridays 10:00 - 13:00 13:45 - 16:30 | 049 843 1056 |
| Middelburg Public Library | Wonderheuvel Grid DBAR Paarde Valley Grid DBAR | 47 Van Reenen Street, Middelburg, 5900 | Mondays - Fridays 09:00 - 16:30 | 049 802 1300 |

The reports as well as the accompanying appendices are also available on SiVEST's website: <http://www.sivest.co.za/>, click on 'Downloads', then browse to the folder '15324 Umsobomvu PV and Grid'. Please reference 'Mooi Plaats / Wonderheuvel / Paarde Valley Grid' in your correspondence, should your comments be project specific.

We would like to thank you in anticipation of your active and meaningful contribution to the BA and public participation processes.

Geagte Belangstellende en/of Geaffekteerde Party,

BASIESE EVALUERINGS (BEs) VIR DIE BEOOGDE ONTWIKKELING VAN DIE DRIE (3) NETWERKVERBINDINGSINFRASTRUKTUURONTWIKKELINGS (SUBSTASIES EN KRAGLYNE) NABY NOUPOORT EN MIDDELBURG IN DIE NOORD- EN OOS-KAAPROVINSIES

- **MOOI PLAATS SUBSTASIES EN KRAGLYN – (DO-verw. No.: Moet nog aangekondig word)**
- **WONDERHEUVEL SUBSTASIES EN KRAGLYN – (DO-verw. No.: Moet nog aangekondig word)**
- **PAARDE VALLEY SUBSTASIES EN KRAGLYN – (DO-verw. No.: Moet nog aangekondig word)**

Ons stel u graag in kennis dat SiVEST SA (Edms) Bpk aangestel is as die onafhanklike Omgewingsevalueringspraktisyn (OEP) om die Basiese Evaluerings- (BE) prosesse vir die bogenoemde voorgestelde projekte te onderneem.

Ons wil graag van hierdie geleentheid gebruik maak om u in te lig dat ingevolge die Nasionale Wet op Omgewingsbestuur (NEMA) (Wet No. 107 van 1998) (soos gewysig), sal die Konsep Basiese Evalueringsverslae (KBEVs) vir die bogenoemde voorgestelde projekte vanaf **Maandag 10 Februarie 2020 tot Woensdag 11 Maart 2020** (teen sluitingstyd) beskikbaar wees vir openbare kommentaar en insae. As u elektroniese kopie van die KBEVs (op CD) wil ontvang, moet u dit asseblief skriftelik by ons versoek. Kommentaar kan soos volg ingedien word:

Hlengiwe Ntuli
 Posbus 2921, RIVONIA, 2128
 Foon: (011) 798 0600
 E-pos: sivest_ppp@sivest.co.za / hlengiwen@sivest.co.za / stephanj@sivest.co.za
 Faks: (011) 803 7272

Gedrukte kopie van die KBEVs kan by die volgende openbare plekke nagegaan word:

| PLEK | VERSLAG / VERSLAE | STRAATADRES | TYE | KONTAKNOMMERS |
|--------------------------------|----------------------------------------|---------------------------------------|-----------------------------------------------------------|---------------|
| Noupoort Publieke Biblioteek | Mooi Plaats Substasie en Kraglyn KBEV | Shawstraat, Noupoort, 5950 | Maandae - Vrydae 10:00 - 13:00 13:45 - 16:30 | 049 843 1056 |
| Middelburg Publieke Biblioteek | Wonderheuvel Substasie en Kraglyn KBEV | Van Reenenstraat 47, Middelburg, 5900 | Maandae - Vrydae 09:00 - 16:30 | 049 802 1300 |

Paarde Valley Substasie
en Kraglyn KBEV

Die verslae, sowel as die meegaande aanhangsels, is ook beskikbaar op SiVEST se webwerf: <http://www.sivest.co.za/>, klik op 'Downloads' en soek dan vir die legger '15324 Umsobomvu PV and Grid'. Verwys asseblief 'Mooi Plaats / Wonderheuvel / Paarde Valley Grid' in u korrespondensie, indien u kommentaar spesifiek op die projek is.

Ons dank u byvoorbaat vir u aktiewe en betekenisvolle bydrae tot die BE en Openbare Deelnameprosesse.

Kind Regards,

Stephan Jacobs (B.Sc. (Hons) Environmental Management and Analysis)

Environmental Consultant / Visual Specialist

SiVEST Environmental Division



SiVEST is a Level 3 BBBEE Contributor

D +27 11 798 0677 | **T** +27 011 798 0600 **E** stephanj@sivest.co.za | **W** www.sivest.co.za

Engineering Consulting | Project Management | Environmental Consulting | Town & Regional Planning | Management Systems Consulting
Durban | Johannesburg | Pretoria | Pietermaritzburg | Richards Bay | Port Louis (Mauritius)

Disclaimer

The information contained in this communication from the sender is confidential. It is intended solely for use by the recipient and others authorized to receive it. If you are not the recipient, you are hereby notified that any disclosure, copying, distribution or taking action in relation of the contents of this information is strictly prohibited and may be unlawful.

This email has been scanned for viruses and malware, and automatically archived by **Mimecast SA (Pty) Ltd**, an innovator in Software as a Service (SaaS) for business. **Mimecast Unified Email Management ??? (UEM)** offers email continuity, security, archiving and compliance with all current legislation. To find out more, [contact Mimecast](#).

sivest_PPP

From: Andre Bodenstein *Transnet Property BLM <Andre.Bodenstein@transnet.net>
Sent: 04 March 2020 12:21 PM
To: sivest_PPP
Cc: Livhuwani Ndou Transnet Freight Rail JHB
Subject: FW: 15324 Three (3) Solar PV Energy Facilities and Grid Infrastructures near Noupoort and Middelburg: DBAR Comment Period Ending

Importance: High

Goo Day

Please provide a locality map/s of the 3 proposed facilities which will enable this office to conduct a proper investigation and respond accordingly.

Kind Regards



André Bodenstein
Geo-Spatial (Inland)
Transnet Property

☎: 051-408 2111 📠: 083 553 0714
📠: 051 408 3310 📧: andre.bodenstein@transnet.net
www.transnet.net

"Good enough should never be good enough"

From: Livhuwani Ndou Transnet Freight Rail JHB
Sent: 04 March 2020 12:13 PM
To: Sam Fiff Transnet Freight Rail BLM; Norman Papenfus Transnet Freight Rail BLM; Johannes Hanekom *Transnet Property CPT; Andre Bodenstein *Transnet Property BLM
Cc: Zanele Manyathi Transnet Freight Rail JHB; Creselda Mangalana Transnet Freight Rail Johannesburg
Subject: FW: 15324 Three (3) Solar PV Energy Facilities and Grid Infrastructures near Noupoort and Middelburg: DBAR Comment Period Ending
Importance: High

Dear Colleagues,

Please review and comment on this proposal.

Kind regards,

Livhuwani

From: Ezekiel Monyamane Transnet Freight Rail JHB
Sent: 04 March 2020 08:31 AM
To: Livhuwani Ndou Transnet Freight Rail JHB <Livhuwani.Ndou@transnet.net>
Subject: FW: 15324 Three (3) Solar PV Energy Facilities and Grid Infrastructures near Noupoort and Middelburg: DBAR Comment Period Ending
Importance: High

FYI

From: sivest_PPP [mailto:sivest_ppp@sivest.co.za]
Sent: 03 March 2020 04:28 PM
Cc: Stephan Jacobs; Liandra Scott-Shaw; 'Sheldon.vandrey@edf-re.co.za'
Subject: RE: 15324 Three (3) Solar PV Energy Facilities and Grid Infrastructures near Noupoort and Middelburg: DBAR Comment Period Ending
Importance: High

Dear Interested and/or Affected Party (I&AP) / Stakeholder,

BASIC ASSESSMENTS (BAs) FOR THE PROPOSED DEVELOPMENT OF THE THREE (3) GRID CONNECTION INFRASTRUCTURE DEVELOPMENTS (SUBSTATIONS AND POWER LINES) NEAR NOUPOORT AND MIDDELBURG IN THE NORTHERN AND EASTERN CAPE PROVINCES

- **Mooi Plaats Grid – (DEA Ref No: To be announced)**
- **Wonderheuvel Grid – (DEA Ref No: To be announced)**
- **Paarde Valley Grid – (DEA Ref No: To be announced)**

Please note that the Draft Basic Assessment Reports (DBARs) for the above-mentioned projects were made available for public review and comment from **Monday the 10th of February 2020 to Wednesday the 11th of March 2020** (end of business day). The review and comment periods for the above-mentioned projects therefore end next week on **Wednesday the 11th of March 2020** (end of business day).

SiVEST therefore wish to remind you to submit comments for the above-mentioned projects (where required). If possible, please submit all comments before or by **Wednesday the 11th of March 2020** (end of business day).

Should you have any comments, please feel free to contact the public participation office at the details below:

SiVEST Environmental
PO Box 2921, RIVONIA, 2128
Phone: (011) 798 0600
E-mail: hlengiwen@sivest.co.za / sivest_ppp@sivest.co.za
Fax: (011) 803 7272

We would like to thank you in anticipation of your active and meaningful contribution to the BA and public participation process.

Kind Regards,

Hlengiwe Ntuli
Projects Secretary and PPP Administrator
SiVEST

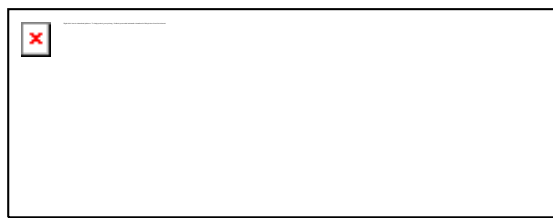

SiVEST is a Level 3 BBBEE Contributor

D +27 11 798 0690 | **T** +27 11 798 0600 | **E** HlengiweN@sivest.co.za | **W** www.sivest.co.za
Engineering Consulting | Project Management | Environmental Consulting | Town & Regional Planning | Management Systems Consulting
Durban | Johannesburg | Pretoria | Pietermaritzburg | Richards Bay | Port Louis (Mauritius)

From: sivest_PPP
Sent: 10 February 2020 05:04 PM
Cc: Stephan Jacobs <StephanJ@sivest.co.za>; Liandra Scott-Shaw <LiandraS@sivest.co.za>; 'Sheldon.vandrey@edf-re.co.za' <Sheldon.vandrey@edf-re.co.za>
Subject: 15324 Three (3) Solar PV Energy Facilities and Grid Infrastructures near Noupoort and Middelburg: DBAR Comment Period Starting

Dear Interested and/or Affected Party (I&AP),

BASIC ASSESSMENTS (BAs) FOR THE PROPOSED DEVELOPMENT OF THE THREE (3) GRID CONNECTION INFRASTRUCTURE DEVELOPMENTS (SUBSTATIONS AND POWER LINES) NEAR NOUPOORT AND MIDDELBURG IN THE NORTHERN AND EASTERN CAPE PROVINCES

- **Mooi Plaats Grid – (DEA Ref No: To be announced)**
- **Wonderheuvel Grid – (DEA Ref No: To be announced)**
- **Paarde Valley Grid – (DEA Ref No: To be announced)**

Please note that SiVEST SA (Pty) Ltd has been appointed as the independent Environmental Assessment Practitioner (EAP) to undertake the Basic Assessment (BA) processes for the above-mentioned proposed projects.

We would like to take this opportunity to inform you that, in accordance with the National Environmental Management Act, 1998 (Act No. 107 of 1998) (NEMA) (as amended), the Draft Basic Assessment Reports (DBARs) for the above-mentioned proposed projects will be available for public comment and review as from **Monday the 10th of February 2020 to Wednesday the 11th of March 2020** (end of business day). Should you wish to receive an electronic copy of the DBARs (on CD), please forward your request in writing to us. Comments can be submitted to:

Hlengiwe Ntuli
PO Box 2921, RIVONIA, 2128
Phone: (011) 798 0600
E-mail: sivest_ppp@sivest.co.za / hlengiwen@sivest.co.za / stephanj@sivest.co.za
Fax: (011) 803 7272

Hard copies of the DBARs can be reviewed at the following public places:

| VENUE | REPORT(S) | STREET ADDRESS | HOURS | CONTACT NO |
|---------------------------|---------------------------------------------------|----------------------------------------|------------------------------------------------------------|--------------|
| Noupoort Public Library | Mooi Plaats Grid DBAR | Shaw St, Noupoort, 5950 | Mondays - Fridays 10:00 - 13:00 13:45 - 16:30 | 049 843 1056 |
| Middelburg Public Library | Wonderheuvel Grid DBAR Paarde Valley Grid DBAR | 47 Van Reenen Street, Middelburg, 5900 | Mondays - Fridays 09:00 - 16:30 | 049 802 1300 |

The reports as well as the accompanying appendices are also available on SiVEST's website: <http://www.sivest.co.za/>, click on 'Downloads', then browse to the folder '15324 Umsobomvu PV and Grid'. Please reference 'Mooi Plaats / Wonderheuvel / Paarde Valley Grid' in your correspondence, should your comments be project specific.

We would like to thank you in anticipation of your active and meaningful contribution to the BA and public participation processes.

Geagte Belangstellende en/of Geaffekteerde Party,

BASIESE EVALUERINGS (BEs) VIR DIE BEOOGDE ONTWIKKELING VAN DIE DRIE (3) NETWERKVERBINDINGSINFRASTRUKTUURONTWIKKELINGS (SUBSTASIES EN KRAGLYNE) NABY NOUPOORT EN MIDDELBURG IN DIE NOORD- EN OOS-KAAPROVINSIES

- **MOOI PLAATS SUBSTASIES EN KRAGLYN – (DO-verw. No.: Moet nog aangekondig word)**
- **WONDERHEUVEL SUBSTASIES EN KRAGLYN – (DO-verw. No.: Moet nog aangekondig word)**
- **PAARDE VALLEY SUBSTASIES EN KRAGLYN – (DO-verw. No.: Moet nog aangekondig word)**

Ons stel u graag in kennis dat SiVEST SA (Edms) Bpk aangestel is as die onafhanklike Omgewingsevalueringspraktisyn (OEP) om die Basiese Evaluerings- (BE) prosesse vir die bogenoemde voorgestelde projekte te onderneem.

Ons wil graag van hierdie geleentheid gebruik maak om u in te lig dat ingevolge die Nasionale Wet op Omgewingsbestuur (NEMA) (Wet No. 107 van 1998) (soos gewysig), sal die Konsep Basiese Evaleeringsverslae (KBEVs) vir die bogenoemde voorgestelde projekte vanaf **Maandag 10 Februarie 2020 tot Woensdag 11 Maart 2020** (teen sluitingstyd) beskikbaar wees vir openbare kommentaar en insae. As u elektroniese kopie van die KBEVs (op CD) wil ontvang, moet u dit asseblief skriftelik by ons versoek. Kommentaar kan soos volg ingedien word:

Hlengiwe Ntuli

Posbus 2921, RIVONIA, 2128

Foon: (011) 798 0600

E-pos: sivest_ppp@sivest.co.za / hlengiwen@sivest.co.za / stephanj@sivest.co.za

Faks: (011) 803 7272

Gedrukte kopies van die KBEVs kan by die volgende openbare plekke nagegaan word:

| PLEK | VERSLAG / VERSLAE | STRAATADRES | TYE | KONTAKNOMMERS |
|--------------------------------------|-----------------------------------------------------------------------------------------|------------------------------------------|---------------------------------------------------------------|---------------|
| Noupoort Publieke Biblioteek | Mooi Plaats Substasie en Kraglyn KBEV | Shawstraat, Noupoort, 5950 | Maandae - Vrydae 10:00 - 13:00 13:45 - 16:30 | 049 843 1056 |
| Middelburg Publieke Biblioteek | Wonderheuvel Substasie en Kraglyn KBEV Paarde Valley Substasie en Kraglyn KBEV | Van Reenenstraat 47, Middelburg, 5900 | Maandae - Vrydae 09:00 - 16:30 | 049 802 1300 |

Die verslae, sowel as die meegaande aanhangsels, is ook beskikbaar op SiVEST se webwerf: <http://www.sivest.co.za/>, klik op 'Downloads' en soek dan vir die legger '15324 Umsobomvu PV and Grid'. Verwys asseblief 'Mooi Plaats / Wonderheuvel / Paarde Valley Grid' in u korrespondensie, indien u kommentaar spesifiek op die projek is.

Ons dank u byvoorbaat vir u aktiewe en betekenisvolle bydrae tot die BE en Openbare Deelnameprosesse.

Kind Regards,

Stephan Jacobs (B.Sc. (Hons) Environmental Management and Analysis)

Environmental Consultant / Visual Specialist

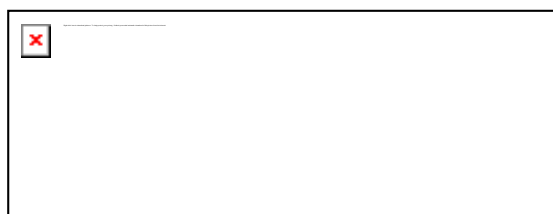
SiVEST Environmental Division**SiVEST is a Level 3 BBBEE Contributor****D** +27 11 798 0677 | **T** +27 011 798 0600 **E** stephanj@sivest.co.za | **W** www.sivest.co.za**Engineering Consulting | Project Management | Environmental Consulting | Town & Regional Planning | Management Systems Consulting**
Durban | Johannesburg | Pretoria | Pietermaritzburg | Richards Bay | Port Louis (Mauritius)**Disclaimer**

The information contained in this communication from the sender is confidential. It is intended solely for use by the recipient and others authorized to receive it. If you are not the recipient, you are hereby notified that any disclosure, copying, distribution or taking action in relation of the contents of this information is strictly prohibited and may be unlawful.

This email has been scanned for viruses and malware, and automatically archived by **Mimecast SA (Pty) Ltd**, an innovator in Software as a Service (SaaS) for business. **Mimecast Unified Email Management ??? (UEM)** offers email continuity, security, archiving and compliance with all current legislation. To find out more, [contact Mimecast](#).

DISCLAIMER: The information contained in this email and its attachments is both confidential and subject to copyright. If you are not the intended recipient, you are hereby notified not to read, disclose copy or use the contents thereof in any manner whatsoever, but are kindly requested to notify the sender and delete it immediately. This e-mail message does not create any legally binding contract between Transnet SOC LTD and the recipient, unless the contrary is specifically stated. Statements and opinions expressed in e-mails may not represent those of Transnet SOC LTD. While Transnet will take reasonable precautions, it cannot give any guarantee or warrant that this email will be free of virus infections, errors, interception and, therefore, cannot be held liable for any loss or damages incurred by the recipient, as a result of any of the above-mentioned factors.

sivest_PPP

From: Mark Moodaley *Transnet Property PLZ <Mark.Moodaley@transnet.net>
Sent: 10 March 2020 12:43 PM
To: sivest_PPP
Cc: Thandeka Nohoyeka Transnet Property PLZ
Subject: FW: 15324 Three (3) Solar PV Energy Facilities and Grid Infrastructures near Noupoort and Middelburg: DBAR Comment Period Ending
Attachments: 4867_001.pdf

Importance: High

Good day,

The subject matter refers.

Kindly note that the notice did not reach us timeously enough for us to provide supporting information to the relevant operating division for comment by 11 March 2020 hence additional time will be required.

Further, it would be appreciated if the following data could be provide to us in CAD or Shape file format in order for us to determine what bearing (if any) this development will have on Transnet land:

1. Foot print of the three solar PV application sites.
2. The grid connection assessment corridors.
3. Proposed On-Site Substations.
4. Foot print of the renewable energy application sites (Solar and Wind).

Thanking you in anticipation.

Kind regards



Mark M Moodaley
Chief Property Technician
Transnet Property
Geo-Spatial: Central Region (Port Elizabeth)
+27 41 507 1319 +27 83 376 3024
+27 11 308 1308 +27 41 507 2884
mark.moodaley@transnet.net
www.transnet.net

From: Johannes Hanekom *Transnet Property CPT <Johannes.Hanekom@transnet.net>
Sent: 06 March 2020 02:56 PM
To: Mark Moodaley *Transnet Property PLZ <Mark.Moodaley@transnet.net>
Cc: Livhuwani Ndou Transnet Freight Rail JHB <Livhuwani.Ndou@transnet.net>; Burton Siljeur *Transnet Property CPT <Burton.Siljeur@transnet.net>
Subject: FW: 15324 Three (3) Solar PV Energy Facilities and Grid Infrastructures near Noupoort and Middelburg: DBAR Comment Period Ending
Importance: High

Good day Mark

Transnet land in the Western Region is not affected by this application.
Central Region office may need to investigate/ assist if they are affected or not.
Please find attached which has been downloaded, for your attention.

With thanks.

Regards



Jaco Hanekom
Senior Property Technician
Geo-Spatial: Western Region
Transnet Property
+27 21 449 4529
Johannes.Hanekom@Transnet.net
www.transnet.net

From: Livhuwani Ndou Transnet Freight Rail JHB
Sent: 04 March 2020 12:13 PM
To: Sam Fiff Transnet Freight Rail BLM; Norman Papenfus Transnet Freight Rail BLM; Johannes Hanekom *Transnet Property CPT; Andre Bodenstein *Transnet Property BLM
Cc: Zanele Manyathi Transnet Freight Rail JHB; Creselda Mangalana Transnet Freight Rail Johannesburg
Subject: FW: 15324 Three (3) Solar PV Energy Facilities and Grid Infrastructures near Noupoort and Middelburg: DBAR Comment Period Ending
Importance: High

Dear Colleagues,

Please review and comment on this proposal.

Kind regards,

Livhuwani

From: Ezekiel Monyamane Transnet Freight Rail JHB
Sent: 04 March 2020 08:31 AM
To: Livhuwani Ndou Transnet Freight Rail JHB <Livhuwani.Ndou@transnet.net>
Subject: FW: 15324 Three (3) Solar PV Energy Facilities and Grid Infrastructures near Noupoort and Middelburg: DBAR Comment Period Ending
Importance: High

FYI

From: sivist_PPP [mailto:sivist_ppp@sivist.co.za]
Sent: 03 March 2020 04:28 PM
Cc: Stephan Jacobs; Liandra Scott-Shaw; 'Sheldon.vandrey@edf-re.co.za'
Subject: RE: 15324 Three (3) Solar PV Energy Facilities and Grid Infrastructures near Noupoort and Middelburg: DBAR Comment Period Ending
Importance: High

Dear Interested and/or Affected Party (I&AP) / Stakeholder,

BASIC ASSESSMENTS (BAs) FOR THE PROPOSED DEVELOPMENT OF THE THREE (3) GRID CONNECTION INFRASTRUCTURE DEVELOPMENTS (SUBSTATIONS AND POWER LINES) NEAR NOUPOORT AND MIDDELBURG IN THE NORTHERN AND EASTERN CAPE PROVINCES

- **Mooi Plaats Grid – (DEA Ref No: To be announced)**
- **Wonderheuvel Grid – (DEA Ref No: To be announced)**
- **Paarde Valley Grid – (DEA Ref No: To be announced)**

Please note that the Draft Basic Assessment Reports (DBARs) for the above-mentioned projects were made available for public review and comment from **Monday the 10th of February 2020 to Wednesday the 11th of March 2020** (end of business day). The review and comment periods for the above-mentioned projects therefore end next week on **Wednesday the 11th of March 2020** (end of business day).

SiVEST therefore wish to remind you to submit comments for the above-mentioned projects (where required). If possible, please submit all comments before or by **Wednesday the 11th of March 2020** (end of business day).

Should you have any comments, please feel free to contact the public participation office at the details below:

SiVEST Environmental
PO Box 2921, RIVONIA, 2128
Phone: (011) 798 0600
E-mail: hlangiwen@sivist.co.za / sivist_ppp@sivist.co.za
Fax: (011) 803 7272

We would like to thank you in anticipation of your active and meaningful contribution to the BA and public participation process.

Kind Regards,
Hlangiwe Ntuli
Projects Secretary and PPP Administrator
SiVEST

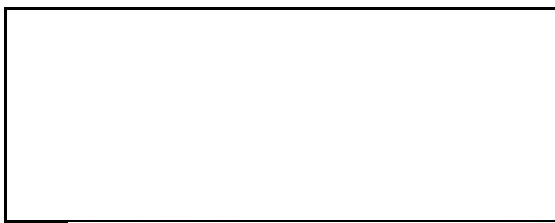

SiVEST is a Level 3 BBBEE Contributor

D +27 11 798 0690 | **T** +27 11 798 0600 | **E** HlangiweN@sivist.co.za | **W** www.sivist.co.za
Engineering Consulting | Project Management | Environmental Consulting | Town & Regional Planning | Management Systems Consulting
Durban | Johannesburg | Pretoria | Pietermaritzburg | Richards Bay | Port Louis (Mauritius)

From: sivist_PPP
Sent: 10 February 2020 05:04 PM
Cc: Stephan Jacobs <StephanJ@sivist.co.za>; Liandra Scott-Shaw <LiandraS@sivist.co.za>; 'Sheldon.vandrey@edf-re.co.za' <Sheldon.vandrey@edf-re.co.za>
Subject: 15324 Three (3) Solar PV Energy Facilities and Grid Infrastructures near Noupoort and Middelburg: DBAR Comment Period Starting

Dear Interested and/or Affected Party (I&AP),

BASIC ASSESSMENTS (BAs) FOR THE PROPOSED DEVELOPMENT OF THE THREE (3) GRID CONNECTION INFRASTRUCTURE DEVELOPMENTS (SUBSTATIONS AND POWER LINES) NEAR NOUPOORT AND MIDDELBURG IN THE NORTHERN AND EASTERN CAPE PROVINCES

- **Mooi Plaats Grid – (DEA Ref No: To be announced)**
- **Wonderheuvel Grid – (DEA Ref No: To be announced)**
- **Paarde Valley Grid – (DEA Ref No: To be announced)**

Please note that SiVEST SA (Pty) Ltd has been appointed as the independent Environmental Assessment Practitioner (EAP) to undertake the Basic Assessment (BA) processes for the above-mentioned proposed projects.

We would like to take this opportunity to inform you that, in accordance with the National Environmental Management Act, 1998 (Act No. 107 of 1998) (NEMA) (as amended), the Draft Basic Assessment Reports (DBARs) for the above-mentioned proposed projects will be available for public comment and review as from **Monday the 10th of**

February 2020 to Wednesday the 11th of March 2020 (end of business day). Should you wish to receive an electronic copy of the DBARs (on CD), please forward your request in writing to us. Comments can be submitted to:

Hlengiwe Ntuli

PO Box 2921, RIVONIA, 2128

Phone: (011) 798 0600

E-mail: sivest_ppp@sivest.co.za / hlengiwen@sivest.co.za / stephanj@sivest.co.za

Fax: (011) 803 7272

Hard copies of the DBARs can be reviewed at the following public places:

| VENUE | REPORT(S) | STREET ADDRESS | HOURS | CONTACT NO |
|---------------------------|---------------------------------------------------|----------------------------------------|------------------------------------------------------------|--------------|
| Noupoort Public Library | Mooi Plaats Grid DBAR | Shaw St, Noupoort, 5950 | Mondays - Fridays 10:00 - 13:00 13:45 - 16:30 | 049 843 1056 |
| Middelburg Public Library | Wonderheuvel Grid DBAR Paarde Valley Grid DBAR | 47 Van Reenen Street, Middelburg, 5900 | Mondays - Fridays 09:00 - 16:30 | 049 802 1300 |

The reports as well as the accompanying appendices are also available on SiVEST's website: <http://www.sivest.co.za/>, click on 'Downloads', then browse to the folder '15324 Umsobomvu PV and Grid'. Please reference 'Mooi Plaats / Wonderheuvel / Paarde Valley Grid' in your correspondence, should your comments be project specific.

We would like to thank you in anticipation of your active and meaningful contribution to the BA and public participation processes.

Geagte Belangstellende en/of Geaffekteerde Party,

BASIESE EVALUERINGS (BEs) VIR DIE BEOOGDE ONTWIKKELING VAN DIE DRIE (3) NETWERKVERBINDINGSINFRASTRUKTUURONTWIKKELINGS (SUBSTASIES EN KRAGLYNE) NABY NOUPOORT EN MIDDELBURG IN DIE NOORD- EN OOS-KAAPPROVINSIES

- **MOOI PLAATS SUBSTASIES EN KRAGLYN – (DO-verw. No.: Moet nog aangekondig word)**
- **WONDERHEUVEL SUBSTASIES EN KRAGLYN – (DO-verw. No.: Moet nog aangekondig word)**
- **PAARDE VALLEY SUBSTASIES EN KRAGLYN – (DO-verw. No.: Moet nog aangekondig word)**

Ons stel u graag in kennis dat SiVEST SA (Edms) Bpk aangestel is as die onafhanklike Omgewingsevalueringspraktisyn (OEP) om die Basiese Evalueerings- (BE) prosesse vir die bogenoemde voorgestelde projekte te onderneem.

Ons wil graag van hierdie geleentheid gebruik maak om u in te lig dat ingevolge die Nasionale Wet op Omgewingsbestuur (NEMA) (Wet No. 107 van 1998) (soos gewysig), sal die Konsep Basiese Evalueeringsverslae (KBEVs) vir die bogenoemde voorgestelde projekte vanaf **Maandag 10 Februarie 2020** tot **Woensdag 11 Maart 2020** (teen sluitingstyd) beskikbaar wees vir openbare kommentaar en insae. As u elektroniese kopie van die KBEVs (op CD) wil ontvang, moet u dit asseblief skriftelik by ons versoek. Kommentaar kan soos volg ingedien word:

Hlengiwe Ntuli

Posbus 2921, RIVONIA, 2128

Foon: (011) 798 0600

E-pos: sivest_ppp@sivest.co.za / hlengiwen@sivest.co.za / stephanj@sivest.co.za

Faks: (011) 803 7272

Gedrukte kopie van die KBEVs kan by die volgende openbare plekke nagegaan word:

| PLEK | VERSLAG / VERSLAE | STRAATADRES | TYE | KONTAKNOMMERS |
|--------------------------------|-----------------------------------------------------------------------------------|---------------------------------------|-----------------------------------------------------------|---------------|
| Noupoort Publieke Biblioteek | Mooi Plaats Substasie en Kraglyn KBEV | Shawstraat, Noupoort, 5950 | Maandae - Vrydae 10:00 - 13:00 13:45 - 16:30 | 049 843 1056 |
| Middelburg Publieke Biblioteek | Wonderheuvel Substasie en Kraglyn KBEV Paarde Valley Substasie en Kraglyn KBEV | Van Reenenstraat 47, Middelburg, 5900 | Maandae - Vrydae 09:00 - 16:30 | 049 802 1300 |

Die verslae, sowel as die meegaande aanhangsels, is ook beskikbaar op SiVEST se webwerf: <http://www.sivest.co.za/>, klik op 'Downloads' en soek dan vir die legger '15324 Umsobomvu PV and Grid'. Verwys asseblief 'Mooi Plaats / Wonderheuvel / Paarde Valley Grid' in u korrespondensie, indien u kommentaar spesifiek op die projek is.

Ons dank u byvoorbaat vir u aktiewe en betekenisvolle bydrae tot die BE en Openbare Deelnameprosesse.

Kind Regards,

Stephan Jacobs (B.Sc. (Hons) Environmental Management and Analysis)

Environmental Consultant / Visual Specialist

SiVEST Environmental Division



Stephan Jacobs

From: Natasha Higgitt <nhiggitt@sahra.org.za>
Sent: Thursday, 12 March 2020 9:23 AM
To: sivist_PPP
Cc: Stephan Jacobs; Liandra Scott-Shaw; 'Sheldon.vandrey@edf-re.co.za'
Subject: RE: 15324 Three (3) Grid Infrastructure Projects (Substations and Power Lines) near Noupoot and Middelburg: DBAR Comment Period Ends

Good morning,

Please note that Final Comments have been issued on SAHRIS Case ID 14884, 14885 and 14944. Please see links to the cases:

<https://sahris.sahra.org.za/cases/mooi-plaats-grid-ba>
<https://sahris.sahra.org.za/cases/wonderheuvel-grid-ba>
<https://sahris.sahra.org.za/cases/paarde-valley-grid-ba>

Kind regards,

From: sivist_PPP <sivist_ppp@sivest.co.za>
Sent: Wednesday, 11 March 2020 11:53
Cc: Stephan Jacobs <StephanJ@sivest.co.za>; Liandra Scott-Shaw <LiandraS@sivest.co.za>; 'Sheldon.vandrey@edf-re.co.za' <Sheldon.vandrey@edf-re.co.za>
Subject: 15324 Three (3) Grid Infrastructure Projects (Substations and Power Lines) near Noupoot and Middelburg: DBAR Comment Period Ends
Importance: High

Dear Interested and/or Affected Party (I&AP) / Stakeholder,

BASIC ASSESSMENTS (BAS) FOR THE PROPOSED DEVELOPMENT OF THE THREE (3) GRID CONNECTION INFRASTRUCTURE DEVELOPMENTS (SUBSTATIONS AND POWER LINES) NEAR NOUPOORT AND MIDDELBURG IN THE NORTHERN AND EASTERN CAPE PROVINCES

- **MOOI PLAATS GRID – (DEA Ref No.: 14/12/16/3/3/1/2132)**
- **WONDERHEUVEL GRID – (DEA Ref No.: 14/12/16/3/3/1/2134)**
- **PAARDE VALLEY GRID – (DEA Ref No.: 14/12/16/3/3/1/2133)**

Please note that the Draft Basic Assessment Reports (DBARs) for the above-mentioned projects were made available for public review and comment from **Monday the 10th of February 2020** to **Wednesday the 11th of March 2020** (end of business day). The review and comment periods for the above-mentioned projects therefore end today, **Wednesday the 11th of March 2020** (end of business day).

SiVEST therefore wish to remind you to submit comments for the above-mentioned projects (where required). If possible, please submit all comments before or by **13:00 on Thursday 12 March 2020**.

Should you have any comments, please feel free to contact the public participation office at the details below:

SiVEST Environmental
PO Box 2921, RIVONIA, 2128
Phone: (011) 798 0600
E-mail: hlangiwen@sivest.co.za / sivist_ppp@sivest.co.za
Fax: (011) 803 7272

We would like to thank you in anticipation of your active and meaningful contribution to the BA and public participation process.

Kind Regards,

Geagte Belangstellende en/of Geaffekteerde Party / Belanghebbende,

BASIESE EVALUERINGSPROSESSE (BE-PROSESSE) VIR DIE BEOOGDE ONTWIKKELING VAN DIE MOOI PLAATS, WONDERHUEVEL EN PAARDE VALLEY SUBSTASIES EN GEASSOSIEERDE 132KV KRAGLYNE NABY NOUPOORT EN MIDDELBURG IN DIE NOORD- EN OOS-KAAPPROVINSIES

- MOOI PLAATS SUBSTASIE EN KRAGLYN – (DO-verw. No.: 14/12/16/3/3/1/2132)
- WONDERHEUVEL SUBSTASIE EN KRAGLYN – (DO-verw. No.: 14/12/16/3/3/1/2134)
- PAARDE VALLEY SUBSTASIES EN KRAGLYN – (DO-verw. No.: 14/12/16/3/3/1/2133)

Neem asseblief kennis dat die Konsep Basiese Evaleeringsverslae (KBEVs) vir die bogenoemde projekte vanaf **Maandag 10 Februarie 2020** tot **Woensdag 11 Maart 2020** (teen sluitingstyd) beskikbaar gestel was vir openbare oorsig en kommentaar. Die oorsig- en kommentaarperiodes vir die bogenoemde projekte eindig dus vandag, **Woensdag 11 Maart 2020** (teen sluitingstyd).

SiVEST wil u dus herinner om kommentaar vir die bogenoemde projekte te lewer (waar nodig). Indien moontlik, lewer asseblief alle kommentaar voor of teen **13:00 op Donderdag 12 Maart 2020**.

Indien u enige kommentaar het, kan u die kantoor vir openbare deelname kontak met die onderstaande besonderhede:

SiVEST Omgewingsafdeling

Posbus 2921, RIVONIA, 2128

Foon: (011) 798 0600

E-pos: hlengiwen@sivest.co.za / sivest_ppp@sivest.co.za

Faks: (011) 803 7272

Ons dank u byvoorbaat vir u aktiewe en betekenisvolle bydrae tot die BE en Openbare Deelnameprosesse.

Vriendelike groete,

Stephan Jacobs (B.Sc. (Hons) Environmental Management and Analysis)

Environmental Consultant / Visual Specialist

SiVEST Environmental Division

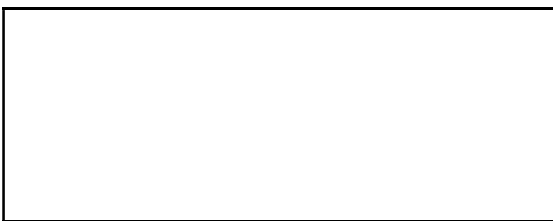

SiVEST is a Level 3 BBBEE Contributor

D +27 11 798 0677 | **T** +27 011 798 0600 **E** stephanj@sivest.co.za | **W** www.sivest.co.za

Engineering Consulting | Project Management | Environmental Consulting | Town & Regional Planning | Management Systems Consulting

Durban | Johannesburg | Pretoria | Pietermaritzburg | Richards Bay | Port Louis (Mauritius)

From: sivest_PPP

Sent: 03 March 2020 04:28 PM

Cc: Stephan Jacobs <StephanJ@sivest.co.za>; Liandra Scott-Shaw <LiandraS@sivest.co.za>; 'Sheldon.vandrey@edf-re.co.za' <Sheldon.vandrey@edf-re.co.za>

Subject: RE: 15324 Three (3) Solar PV Energy Facilities and Grid Infrastructures near Noupoort and Middelburg: DBAR Comment Period Ending

Importance: High

Dear Interested and/or Affected Party (I&AP) / Stakeholder,

BASIC ASSESSMENTS (BAs) FOR THE PROPOSED DEVELOPMENT OF THE THREE (3) GRID CONNECTION INFRASTRUCTURE DEVELOPMENTS (SUBSTATIONS AND POWER LINES) NEAR NOUPOORT AND MIDDELBURG IN THE NORTHERN AND EASTERN CAPE PROVINCES

- **Mooi Plaats Grid – (DEA Ref No: To be announced)**
- **Wonderheuvel Grid – (DEA Ref No: To be announced)**
- **Paarde Valley Grid – (DEA Ref No: To be announced)**

Please note that the Draft Basic Assessment Reports (DBARs) for the above-mentioned projects were made available for public review and comment from **Monday the 10th of February 2020 to Wednesday the 11th of March 2020** (end of business day). The review and comment periods for the above-mentioned projects therefore end next week on **Wednesday the 11th of March 2020** (end of business day).

SiVEST therefore wish to remind you to submit comments for the above-mentioned projects (where required). If possible, please submit all comments before or by **Wednesday the 11th of March 2020** (end of business day).

Should you have any comments, please feel free to contact the public participation office at the details below:

SiVEST Environmental

PO Box 2921, RIVONIA, 2128

Phone: (011) 798 0600

E-mail: hlengiwen@sivest.co.za / sivest_ppp@sivest.co.za

Fax: (011) 803 7272

We would like to thank you in anticipation of your active and meaningful contribution to the BA and public participation process.

Kind Regards,

Hlengiwe Ntuli

Projects Secretary and PPP Administrator

SiVEST

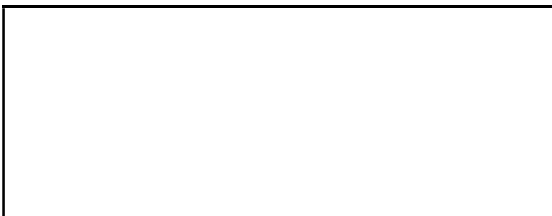

SiVEST is a Level 3 BBBEE Contributor

D +27 11 798 0690 | **T** +27 11 798 0600 | **E** HlengiweN@sivest.co.za | **W** www.sivest.co.za

Engineering Consulting | Project Management | Environmental Consulting | Town & Regional Planning | Management Systems Consulting

From: sivest_ppp
Sent: 10 February 2020 05:04 PM
Cc: Stephan Jacobs <StephanJ@sivest.co.za>; Liandra Scott-Shaw <LiandraS@sivest.co.za>; 'Sheldon.vandrey@edf-re.co.za' <Sheldon.vandrey@edf-re.co.za>
Subject: 15324 Three (3) Solar PV Energy Facilities and Grid Infrastructures near Noupoort and Middelburg: DBAR Comment Period Starting

Dear Interested and/or Affected Party (I&AP),

BASIC ASSESSMENTS (BAs) FOR THE PROPOSED DEVELOPMENT OF THE THREE (3) GRID CONNECTION INFRASTRUCTURE DEVELOPMENTS (SUBSTATIONS AND POWER LINES) NEAR NOUPOORT AND MIDDELBURG IN THE NORTHERN AND EASTERN CAPE PROVINCES

- **Mooi Plaats Grid – (DEA Ref No: To be announced)**
- **Wonderheuvel Grid – (DEA Ref No: To be announced)**
- **Paarde Valley Grid – (DEA Ref No: To be announced)**

Please note that SiVEST SA (Pty) Ltd has been appointed as the independent Environmental Assessment Practitioner (EAP) to undertake the Basic Assessment (BA) processes for the above-mentioned proposed projects.

We would like to take this opportunity to inform you that, in accordance with the National Environmental Management Act, 1998 (Act No. 107 of 1998) (NEMA) (as amended), the Draft Basic Assessment Reports (DBARs) for the above-mentioned proposed projects will be available for public comment and review as from **Monday the 10th of February 2020 to Wednesday the 11th of March 2020** (end of business day). Should you wish to receive an electronic copy of the DBARs (on CD), please forward your request in writing to us. Comments can be submitted to:

Hlengiwe Ntuli
PO Box 2921, RIVONIA, 2128
Phone: (011) 798 0600
E-mail: sivest_ppp@sivest.co.za / hlengiwen@sivest.co.za / stephanj@sivest.co.za
Fax: (011) 803 7272

Hard copies of the DBARs can be reviewed at the following public places:

| VENUE | REPORT(S) | STREET ADDRESS | HOURS | CONTACT NO |
|---------------------------|-------------------------|----------------------------------------|----------------------------------------------------------------|-----------------|
| Noupoort Public Library | Mooi Plaats Grid DBAR | Shaw St, Noupoort, 5950 | Mondays - Fridays 10:00 - 13:00 13:45 - 16:30 | 049 843 1056 |
| | Wonderheuvel Grid DBAR | | Mondays - Fridays 09:00 - 16:30 | |
| Middelburg Public Library | Paarde Valley Grid DBAR | 47 Van Reenen Street, Middelburg, 5900 | Mondays - Fridays 09:00 - 16:30 | 049 802 1300 |

The reports as well as the accompanying appendices are also available on SiVEST's website: <http://www.sivest.co.za/>, click on 'Downloads', then browse to the folder '15324 Umsobomvu PV and Grid'. Please reference 'Mooi Plaats / Wonderheuvel / Paarde Valley Grid' in your correspondence, should your comments be project specific.

We would like to thank you in anticipation of your active and meaningful contribution to the BA and public participation processes.

Geagte Belangstellende en/of Geaffekteerde Party,

BASIESE EVALUERINGS (BEs) VIR DIE BEOOGDE ONTWIKKELING VAN DIE DRIE (3) NETWERKVERBINDINGSINFRASTRUKTUURONTWIKKELINGS (SUBSTASIES EN KRAGLYNE) NABY NOUPOORT EN MIDDELBURG IN DIE NOORD- EN OOS-KAAPPROVINSIES

- MOOI PLAATS SUBSTASIES EN KRAGLYN – (DO-verw. No.: Moet nog aangekondig word)
- WONDERHEUVEL SUBSTASIES EN KRAGLYN – (DO-verw. No.: Moet nog aangekondig word)
- PAARDE VALLEY SUBSTASIES EN KRAGLYN – (DO-verw. No.: Moet nog aangekondig word)

Ons stel u graag in kennis dat SiVEST SA (Edms) Bpk aangestel is as die onafhanklike Omgewingsevalueringspraktisyn (OEP) om die Basiese Evalueerings- (BE) prosesse vir die bogenoemde voorgestelde projekte te onderneem.

Ons wil graag van hierdie geleentheid gebruik maak om u in te lig dat ingevolge die Nasionale Wet op Omgewingsbestuur (NEMA) (Wet No. 107 van 1998) (soos gewysig), sal die Konsep Basiese Evalueeringsverslae (KBEVs) vir die bogenoemde voorgestelde projekte vanaf **Maandag 10 Februarie 2020** tot **Woensdag 11 Maart 2020** (teen sluitingstyd) beskikbaar wees vir openbare kommentaar en insae. As u elektroniese kopies van die KBEVs (op CD) wil ontvang, moet u dit asseblief skriftelik by ons versoek. Kommentaar kan soos volg ingedien word:

Hlengiwe Ntuli

Posbus 2921, RIVONIA, 2128

Foon: (011) 798 0600

E-pos: sivest_ppp@sivest.co.za / hlengiwen@sivest.co.za / stephanj@sivest.co.za

Faks: (011) 803 7272

Gedrukte kopies van die KBEVs kan by die volgende openbare plekke nagegaan word:

| PLEK | VERSLAG / VERSLAE | STRAATADRES | TYE | KONTAKNOMMERS |
|--------------------------------------|-----------------------------------------------------------------------------------------------|------------------------------------------|--------------------------------------|---------------|
| Noupoort Publieke Biblioteek | Mooi Plaats Substasie en Kraglyn KBEV | Shawstraat, Noupoort, 5950 | Maandae - Vrydae | 049 843 1056 |
| | | | 10:00 - 13:00 13:45 - 16:30 | |
| Middelburg Publieke Biblioteek | Wonderheuvel Substasie en Kraglyn KBEV Paarde Valley Substasie en Kraglyn KBEV | Van Reenenstraat 47, Middelburg, 5900 | Maandae - Vrydae | 049 802 1300 |
| | | | 09:00 - 16:30 | |

Die verslae, sowel as die meegaande aanhangsels, is ook beskikbaar op SiVEST se webwerf: <http://www.sivest.co.za/>, klik op 'Downloads' en soek dan vir die legger '15324 Umsobomvu PV and Grid'. Verwys asseblief 'Mooi Plaats / Wonderheuvel / Paarde Valley Grid' in u korrespondensie, indien u kommentaar spesifiek op die projek is.

Ons dank u byvoorbaat vir u aktiewe en betekenisvolle bydrae tot die BE en Openbare Deelnameprosesse.

Kind Regards,

Stephan Jacobs (B.Sc. (Hons) Environmental Management and Analysis)

Environmental Consultant / Visual Specialist

SiVEST Environmental Division

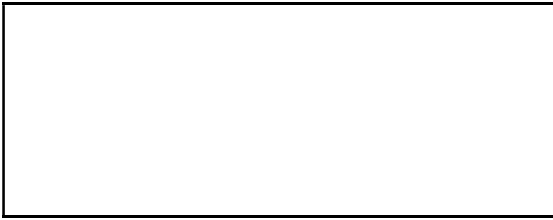

SIVEST is a Level 3 BBBEE Contributor

D +27 11 798 0677 | **T** +27 011 798 0600 **E** stephanj@sivest.co.za | **W** www.sivest.co.za
Engineering Consulting | Project Management | Environmental Consulting | Town & Regional Planning | Management Systems Consulting
Durban | Johannesburg | Pretoria | Pietermaritzburg | Richards Bay | Port Louis (Mauritius)

Natasha Higgitt

Heritage Officer: Archaeology, Palaeontology and Meteorites Unit

South African Heritage Resources Agency
- A nation united through heritage -

T: +27 21 462 4502/ 8660 | **C:**+27 82 507 0378| **F:**+27 21 462 4509
E: nhiggitt@sahra.org.za | 111 Harrington Street | Cape Town |

www.sahra.org.za



an agency of the
Department of Arts and Culture

OUR VALUES: *Accountability, Teamwork & co-operation, Respect, Transparency, Service Excellency, Integrity & Ethics, Professionalism, Accessibility, Communication & Trust.*

BREAK THE CORRUPTION CHAIN
REPORT FRAUD & CORRUPTION: 0800 701 701



an agency of the
Department of Arts and Culture



Our Ref:



an agency of the
Department of Arts and Culture

T: +27 21 462 4502 | F: +27 21 462 4509 | E: info@sahra.org.za
South African Heritage Resources Agency | 111 Harrington Street | Cape Town
P.O. Box 4637 | Cape Town | 8001
www.sahra.org.za

Enquiries: Natasha Higgitt
Tel: 021 462 4502
Email: nhiggitt@sahra.org.za
CaseID: 14885

Date: Thursday March 12, 2020
Page No: 1

Final Comment

In terms of Section 38(4), 38(8) of the National Heritage Resources Act (Act 25 of 1999)

Attention: SiVEST SA (Pty) Ltd

Proposed Development of the Wonderheuvel On-site Eskom Substation, Eskom Collector Substation and associated 132kV Power Line near Noupoort and Middelburg in the Northern and Eastern Cape Provinces

Sivest SA (Pty) Ltd has been appointed by Wonderheuvuel Solar Power (Pty) Ltd to conduct an Environmental Authorisation (EA) Application process for the proposed Wonderheuvel on-site Eskom substation, Eskom Collector Substation and associated 132kV powerline near Noupoort in the Eastern and Northern Cape Province.

*It must be noted that the following comments are issued for the Northern Cape sections of the proposed development. Comments from the Eastern Cape Provincial Heritage Resources Authority (ECPHRA) must be sought for the Eastern Cape sections of the proposed development.

A draft Basic Assessment Report (BAR) has been submitted in terms of the National Environmental Management Act, 107 of 1998 (NEMA) and NEMA Environmental Impact Assessment (EIA) Regulations. The proposed development will include a 132kV powerline (30.03 km) and substations. A corridor of between 400 m and 900 m wide has been assessed as part of the EA application.

Banzai Environmental and PGS Heritage (Pty) Ltd has been appointed to provide heritage specialist input as part of the EA process as per section 38(3) and 38(8) of the National Heritage Resources Act, Act 25 of 1999 (NHRA) as required by section 24(4)b(iii) of NEMA.

Butler, E. 2019. Palaeontological Field Assessment for the proposed Solar PV Facilities, Northern and Eastern Cape.

**Only the results for the Wonderheuvel Grid infrastructure will be discussed below.*

The proposed development area is underlain by the Adelaide Subgroup with a small section located in the Tarkastad Subgroup and a smaller section located in the Karoo Dolerite Suite. These rocks are overlain by



an agency of the
Department of Arts and Culture

T: +27 21 462 4502 | F: +27 21 462 4509 | E: info@sahra.org.za
South African Heritage Resources Agency | 111 Harrington Street | Cape Town
P.O. Box 4637 | Cape Town | 8001
www.sahra.org.za

Enquiries: Natasha Higgitt
Tel: 021 462 4502
Email: nhiggitt@sahra.org.za
CaseID: 14885

Date: Thursday March 12, 2020
Page No: 2

Quaternary aeolian and superficial deposits. No fossils are evident in the Karoo Dolerite Suite, while the Adelaide Subgroup is known to include vertebrate and invertebrate fossils, plant remains and trace fossils. Some vertebrate fossils are known to be present in the Tarkastad Subgroup rocks including fossil fish, millipedes and trace fossils. Quaternary group fossils are rare and include mammalian fossils, reptiles, shells, plant remains, stromatolites and trace fossils. One in-situ *Lystrosaurus* skull from the Tarkastad Subgroup was identified on Mooi Plaats 121, approximately 80 m from Powerline Route Alternative 2 and 3.

Recommendations provided in the report include the following:

- It is recommended that a 50 m buffer will be placed around the *Lystrosaurus* skull. It has been identified as Highly Sensitive and No-go area.
- In the event that construction is necessary in this sensitive area, it is recommended that the fossil be collected by a professional palaeontologist. Preceding excavation of any fossil material, the specialist would need to apply for a collection permit from SAHRA. Fossil material must be curated in an accredited collection (museum or university collection), while all fieldwork and reports should meet the minimum standards for palaeontological impact studies suggested by SAHRA;
- A Chance Fossils Finds Procedure has been recommended and provided in the report.

Fourie, W. 2019. Heritage Impact Report: Proposed Umsobomvu Solar PV Energy Facilities.

**Only the results for the Wonderheuvel Grid infrastructure will be discussed below.*

A total of four heritage resources were identified within the proposed powerline routes. These include two small, circular shaped stone walled enclosure of medium significance (UMS004 and UMS006A), and two low-density surface scatter of Later Stone Age (LSA) lithics (UMS005 and 005B). The *Lystrosaurus* skull noted in the HIA report (UMS10A and UMS10B) was discussed in the Palaeontological report above.

Recommendations provided in the report include the following:

- Implement a 30 m buffer around heritage sites;
- Development of chance finds procedure to be included in the EMPr.

Final Comment



an agency of the
Department of Arts and Culture

T: +27 21 462 4502 | F: +27 21 462 4509 | E: info@sahra.org.za
South African Heritage Resources Agency | 111 Harrington Street | Cape Town
P.O. Box 4637 | Cape Town | 8001
www.sahra.org.za

*It must be noted that the following comments are issued for the Northern Cape sections of the proposed development. Comments from the ECPHRA must be sought for the Eastern Cape sections of the proposed development.

The following comments are made as a requirement in terms of section 3(4) of the NEMA Regulations and section 38(8) of the NHRA in the format provided in section 38(4) of the NHRA and must be included in the Final BAR and EMPr:

- 38(4)a – The SAHRA Archaeology, Palaeontology and Meteorites (APM) Unit no objections to the proposed development;
- 38(4)b – The recommendations of the specialists are supported and must be adhered to. Additional further additional specific conditions are provided for the development as follows:
- 38(4)c(i) – If any evidence of archaeological sites or remains (e.g. remnants of stone-made structures, indigenous ceramics, bones, stone artefacts, ostrich eggshell fragments, charcoal and ash concentrations), fossils or other categories of heritage resources are found during the proposed development, SAHRA APM Unit (Natasha Higgitt/Phillip Hine 021 462 5402) must be alerted as per section 35(3) of the NHRA. Non-compliance with section of the NHRA is an offense in terms of section 51(1)e of the NHRA and item 5 of the Schedule;
- 38(4)c(ii) – If unmarked human burials are uncovered, the SAHRA Burial Grounds and Graves (BGG) Unit (Thingahangwi Tshivhase/Mimi Seetelo 012 320 8490), must be alerted immediately as per section 36(6) of the NHRA. Non-compliance with section of the NHRA is an offense in terms of section 51(1)e of the NHRA and item 5 of the Schedule;
- 38(4)d – See section 51(1) of the NHRA;
- 38(4)e – The following conditions apply with regards to the appointment of specialists:
 - i) If heritage resources are uncovered during the course of the development, a professional archaeologist or palaeontologist, depending on the nature of the finds, must be contracted as soon as possible to inspect the heritage resource. If the newly discovered heritage resources prove to be of archaeological or palaeontological significance, a Phase 2 rescue operation may be required subject to permits issued by SAHRA;
- As the BAR has been finalised without a Final Comment from SAHRA, this comment must be forwarded directly to the competent authority for their consideration in the decision-making process as per section 38(8) of the NHRA. Proof of the delivery and receipt thereof must be uploaded to the SAHRIS case for record purposes;
- The Final BAR and EMPr must be submitted to SAHRA for record purposes;

Our Ref:



an agency of the
Department of Arts and Culture

T: +27 21 462 4502 | F: +27 21 462 4509 | E: info@sahra.org.za
South African Heritage Resources Agency | 111 Harrington Street | Cape Town
P.O. Box 4637 | Cape Town | 8001
www.sahra.org.za

Enquiries: Natasha Higgitt
Tel: 021 462 4502
Email: nhiggitt@sahra.org.za
CaseID: 14885

Date: Thursday March 12, 2020
Page No: 4

- The decision regarding the EA Application must be communicated to SAHRA and uploaded to the SAHRIS Case application.

Should you have any further queries, please contact the designated official using the case number quoted above in the case header.

Yours faithfully

Natasha Higgitt
Heritage Officer
South African Heritage Resources Agency

Phillip Hine
Manager: Archaeology, Palaeontology and Meteorites Unit
South African Heritage Resources Agency

ADMIN:

Direct URL to case: <http://www.sahra.org.za/node/534629>
(DEA, Ref: 14/12/16/3/3/1/2134)

Terms & Conditions:

1. This approval does not exonerate the applicant from obtaining local authority approval or any other necessary approval for proposed work.
2. If any heritage resources, including graves or human remains, are encountered they must be reported to SAHRA immediately.
3. SAHRA reserves the right to request additional information as required.

Stephan Jacobs

From: Zanoxolo Pama Transnet Property BLM <Zanoxolo.Pama@transnet.net>
Sent: Tuesday, 17 March 2020 8:53 AM
To: Stephan Jacobs; Livhuwani Ndou Transnet Freight Rail JHB
Subject: RE: 15324 Three (3) Solar PV Energy Facilities and Grid Infrastructures near Noupoot and Middelburg; DBAR Comment Period Ending

Good day all

Please be informed that Transnet will NOT be affected by this proposal as the areas of interest are too far from any Transnet land.

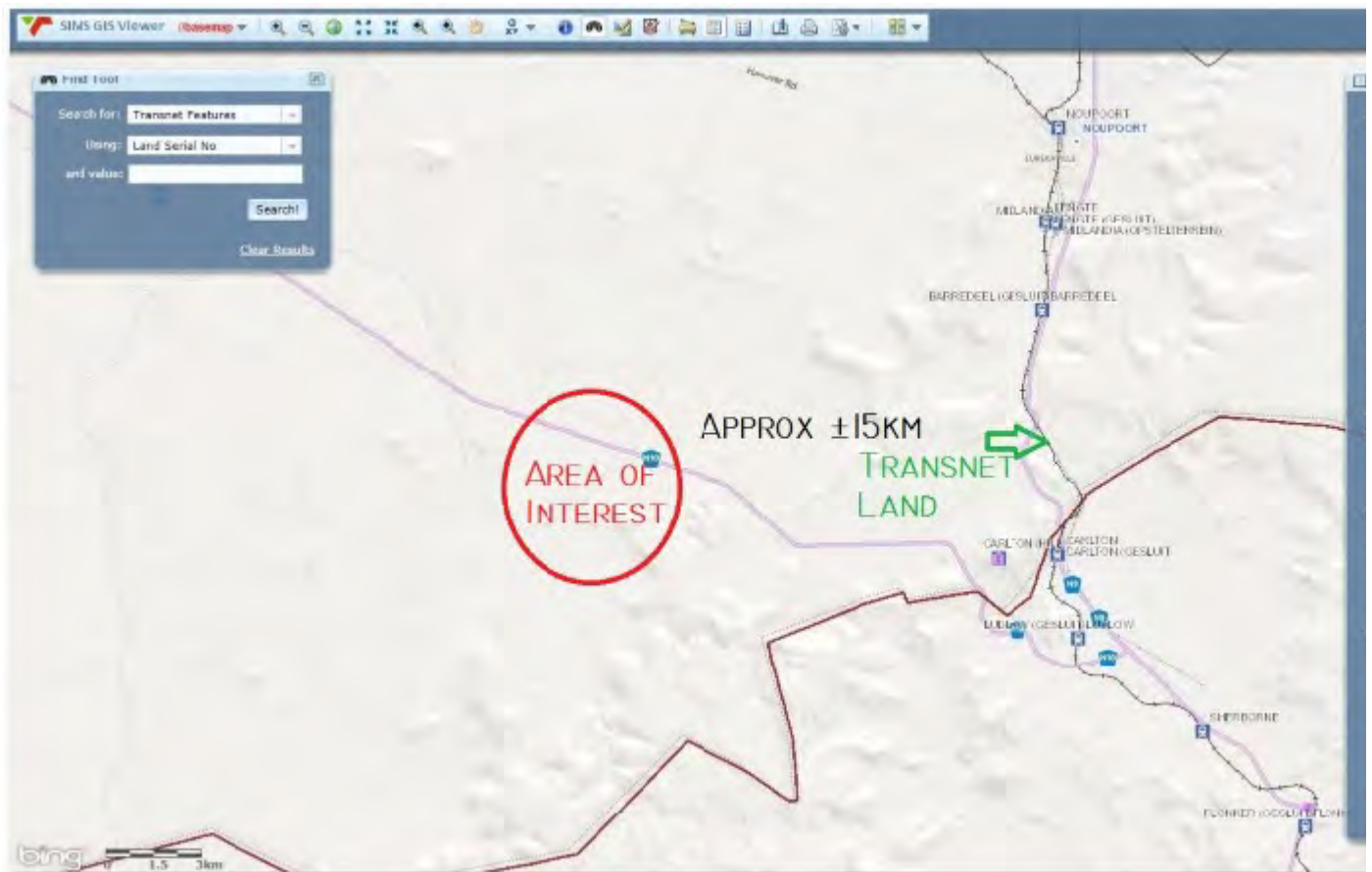

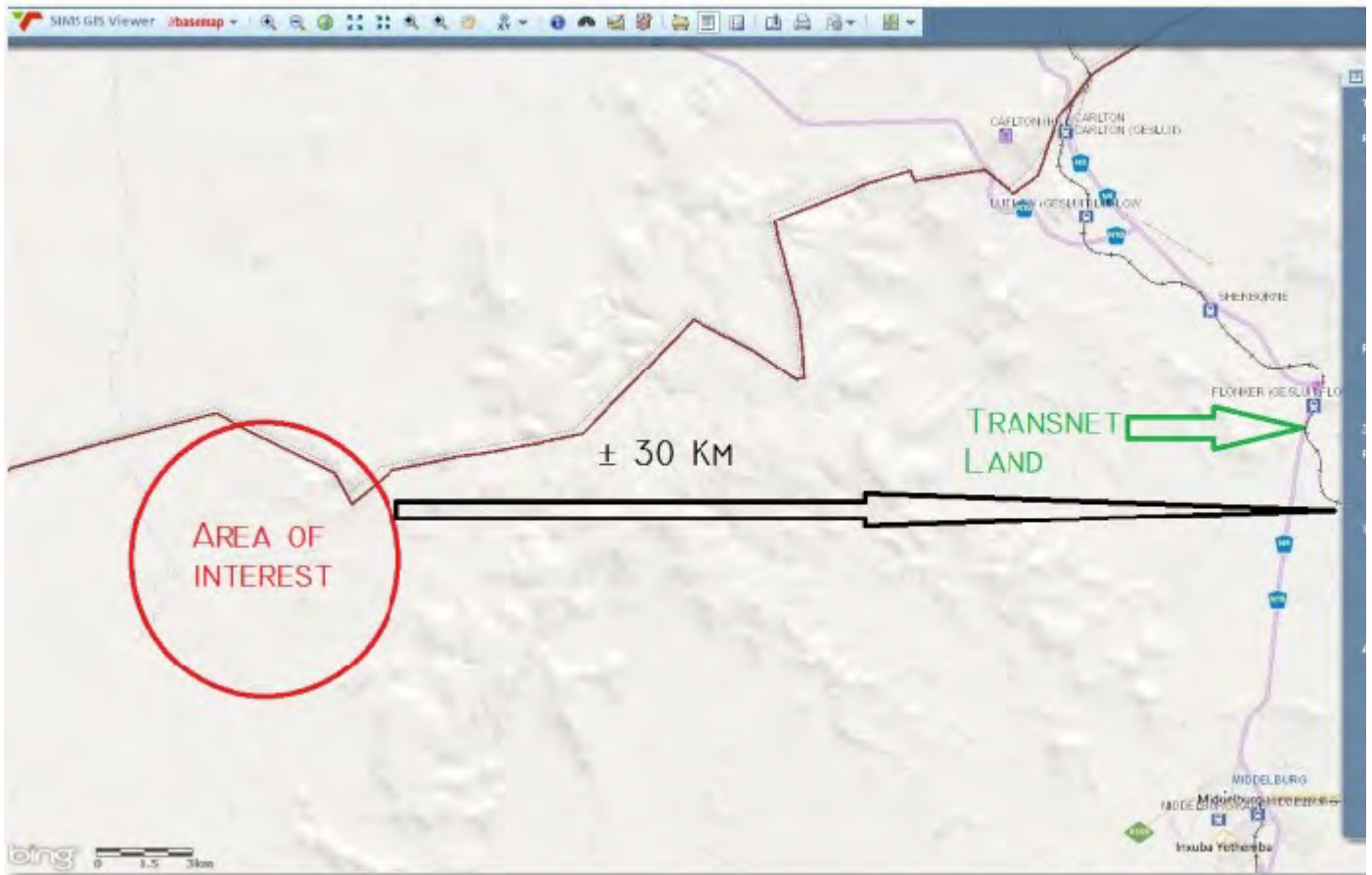

Best Wishes



Zanoxolo Pama
Transnet Property
Geo - Spatial Office (Inland Region)

☎: 051 408 2149
☎: 051 408 3310
✉: Zanoxolo.Pama@Transnet.net
🌐: www.transnet.net

From: Andre Bodenstein *Transnet Property BLM

Sent: 16 March 2020 10:14 AM

To: Zanoxolo Pama Transnet Property BLM <Zanoxolo.Pama@transnet.net>

Subject: FW: 15324 Three (3) Solar PV Energy Facilities and Grid Infrastructures near Noupoort and Middelburg: DBAR Comment Period Ending

Importance: High

Hi Zano

Will you please urgently investigate if any of the three sites will have an impact to Transnet and respond to Livhuwani Ndou of Transnet Freight Rail JHB and to the consultant as he indicated that the application is already with DEA.

Regards



André Bodenstein
Geo-Spatial (Inland)
Transnet Property

☎: 051-408 2111 📠: 083 553 0714
📠: 051 408 3310 ✉: andre.bodenstein@transnet.net
www.transnet.net

“Good enough should never be good enough”

From: Stephan Jacobs [<mailto:StephanJ@sivest.co.za>]
Sent: 16 March 2020 10:06 AM
To: Andre Bodenstein *Transnet Property BLM
Cc: Livhuwani Ndou Transnet Freight Rail JHB; sivest_PPP; Liandra Scott-Shaw
Subject: RE: 15324 Three (3) Solar PV Energy Facilities and Grid Infrastructures near Noupoot and Middelburg: DBAR Comment Period Ending
Importance: High

Good Morning Mr Bodenstein,

I trust you are well.

The email below refers.

As requested, please find attached locality maps of the 3 proposed solar PV energy facilities and associated grid connection projects (substations and power lines).

Please be advised that SiVEST have already submitted the Final EIA Reports (FEIARs) for the to 3 proposed solar PV energy facilities to the competent authority (namely the DEA) for decision-making. SiVEST will however forward your comments with regards to these projects directly to the competent authority (namely the DEA) for consideration, should you have any.

We trust that you will find everything in order.

Please do not hesitate to contact us should there be any issues or should you have any further queries etc.

Kind Regards,

Stephan Jacobs (B.Sc. (Hons) Environmental Management and Analysis)
Environmental Consultant / Visual Specialist
SiVEST Environmental Division



SiVEST is a Level 3 BBBEE Contributor

D +27 11 798 0677 | **T** +27 011 798 0600 | **M** +27 72 737 2114 **E** stephanj@sivest.co.za | **W** www.sivest.co.za

Engineering Consulting | Project Management | Environmental Consulting | Town & Regional Planning | Management Systems Consulting
Durban | Johannesburg | Pretoria | Pietermaritzburg | Richards Bay | Port Louis (Mauritius)

From: Andre Bodenstein *Transnet Property BLM [<mailto:Andre.Bodenstein@transnet.net>]
Sent: Wednesday, 04 March 2020 12:21 PM
To: sivest_PPP <sivest_ppp@sivest.co.za>
Cc: Livhuwani Ndou Transnet Freight Rail JHB <Livhuwani.Ndou@transnet.net>
Subject: FW: 15324 Three (3) Solar PV Energy Facilities and Grid Infrastructures near Noupoort and Middelburg: DBAR Comment Period Ending
Importance: High

Goo Day

Please provide a locality map/s of the 3 proposed facilities which will enable this office to conduct a proper investigation and respond accordingly.

Kind Regards



André Bodenstein
Geo-Spatial (Inland)
Transnet Property

☎: 051-408 2111 📠: 083 553 0714
📠: 051 408 3310 📧: andre.bodenstein@transnet.net
www.transnet.net

"Good enough should never be good enough"

From: Livhuwani Ndou Transnet Freight Rail JHB
Sent: 04 March 2020 12:13 PM
To: Sam Fiff Transnet Freight Rail BLM; Norman Papenfus Transnet Freight Rail BLM; Johannes Hanekom *Transnet Property CPT; Andre Bodenstein *Transnet Property BLM
Cc: Zanele Manyathi Transnet Freight Rail JHB; Creselda Mangalana Transnet Freight Rail Johannesburg
Subject: FW: 15324 Three (3) Solar PV Energy Facilities and Grid Infrastructures near Noupoort and Middelburg: DBAR Comment Period Ending
Importance: High

Dear Colleagues,

Please review and comment on this proposal.

Kind regards,

Livhuwani

From: Ezekiel Monyamane Transnet Freight Rail JHB
Sent: 04 March 2020 08:31 AM
To: Livhuwani Ndou Transnet Freight Rail JHB <Livhuwani.Ndou@transnet.net>
Subject: FW: 15324 Three (3) Solar PV Energy Facilities and Grid Infrastructures near Noupoort and Middelburg: DBAR Comment Period Ending
Importance: High

FYI

From: sivest_PPP [mailto:sivest_ppp@sivest.co.za]
Sent: 03 March 2020 04:28 PM
Cc: Stephan Jacobs; Liandra Scott-Shaw; 'Sheldon.vandrey@edf-re.co.za'
Subject: RE: 15324 Three (3) Solar PV Energy Facilities and Grid Infrastructures near Noupoort and Middelburg:

DBAR Comment Period Ending
Importance: High

Dear Interested and/or Affected Party (I&AP) / Stakeholder,

BASIC ASSESSMENTS (BAs) FOR THE PROPOSED DEVELOPMENT OF THE THREE (3) GRID CONNECTION INFRASTRUCTURE DEVELOPMENTS (SUBSTATIONS AND POWER LINES) NEAR NOUPOORT AND MIDDELBURG IN THE NORTHERN AND EASTERN CAPE PROVINCES

- Mooi Plaats Grid – (DEA Ref No: To be announced)
- Wonderheuvel Grid – (DEA Ref No: To be announced)
- Paarde Valley Grid – (DEA Ref No: To be announced)

Please note that the Draft Basic Assessment Reports (DBARs) for the above-mentioned projects were made available for public review and comment from **Monday the 10th of February 2020 to Wednesday the 11th of March 2020** (end of business day). The review and comment periods for the above-mentioned projects therefore end next week on **Wednesday the 11th of March 2020** (end of business day).

SiVEST therefore wish to remind you to submit comments for the above-mentioned projects (where required). If possible, please submit all comments before or by **Wednesday the 11th of March 2020** (end of business day).

Should you have any comments, please feel free to contact the public participation office at the details below:

SiVEST Environmental
PO Box 2921, RIVONIA, 2128
Phone: (011) 798 0600
E-mail: hlengiwen@sivest.co.za / sivest_ppp@sivest.co.za
Fax: (011) 803 7272

We would like to thank you in anticipation of your active and meaningful contribution to the BA and public participation process.

Kind Regards,
Hlengiwe Ntuli
Projects Secretary and PPP Administrator
SiVEST

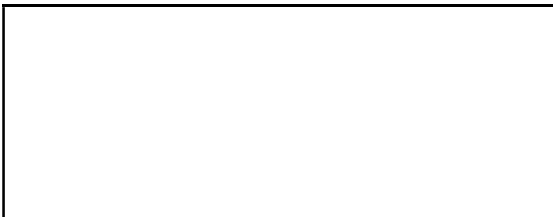

SiVEST is a Level 3 BBBEE Contributor

D +27 11 798 0690 | T +27 11 798 0600 | E HlengiweN@sivest.co.za | W www.sivest.co.za
Engineering Consulting | Project Management | Environmental Consulting | Town & Regional Planning | Management Systems Consulting
Durban | Johannesburg | Pretoria | Pietermaritzburg | Richards Bay | Port Louis (Mauritius)

From: sivest_PPP
Sent: 10 February 2020 05:04 PM
Cc: Stephan Jacobs <StephanJ@sivest.co.za>; Liandra Scott-Shaw <LiandraS@sivest.co.za>; Sheldon.vandrey@edf-

re.co.za' <Sheldon.vandrey@edf-re.co.za>

Subject: 15324 Three (3) Solar PV Energy Facilities and Grid Infrastructures near Noupoort and Middelburg: DBAR Comment Period Starting

Dear Interested and/or Affected Party (I&AP),

BASIC ASSESSMENTS (BAs) FOR THE PROPOSED DEVELOPMENT OF THE THREE (3) GRID CONNECTION INFRASTRUCTURE DEVELOPMENTS (SUBSTATIONS AND POWER LINES) NEAR NOUPOORT AND MIDDELBURG IN THE NORTHERN AND EASTERN CAPE PROVINCES

- **Mooi Plaats Grid – (DEA Ref No: To be announced)**
- **Wonderheuveld Grid – (DEA Ref No: To be announced)**
- **Paarde Valley Grid – (DEA Ref No: To be announced)**

Please note that SiVEST SA (Pty) Ltd has been appointed as the independent Environmental Assessment Practitioner (EAP) to undertake the Basic Assessment (BA) processes for the above-mentioned proposed projects.

We would like to take this opportunity to inform you that, in accordance with the National Environmental Management Act, 1998 (Act No. 107 of 1998) (NEMA) (as amended), the Draft Basic Assessment Reports (DBARs) for the above-mentioned proposed projects will be available for public comment and review as from **Monday the 10th of February 2020 to Wednesday the 11th of March 2020** (end of business day). Should you wish to receive an electronic copy of the DBARs (on CD), please forward your request in writing to us. Comments can be submitted to:

Hlengiwe Ntuli

PO Box 2921, RIVONIA, 2128

Phone: (011) 798 0600

E-mail: sivest_ppp@sivest.co.za / hlengiwen@sivest.co.za / stephanj@sivest.co.za

Fax: (011) 803 7272

Hard copies of the DBARs can be reviewed at the following public places:

| VENUE | REPORT(S) | STREET ADDRESS | HOURS | CONTACT NO |
|---------------------------|----------------------------------------------------|----------------------------------------|------------------------------------------------------------|--------------|
| Noupoort Public Library | Mooi Plaats Grid DBAR | Shaw St, Noupoort, 5950 | Mondays - Fridays 10:00 - 13:00 13:45 - 16:30 | 049 843 1056 |
| Middelburg Public Library | Wonderheuveld Grid DBAR Paarde Valley Grid DBAR | 47 Van Reenen Street, Middelburg, 5900 | Mondays - Fridays 09:00 - 16:30 | 049 802 1300 |

The reports as well as the accompanying appendices are also available on SiVEST's website: <http://www.sivest.co.za/>, click on 'Downloads', then browse to the folder '15324 Umsobomvu PV and Grid'. Please reference 'Mooi Plaats / Wonderheuveld / Paarde Valley Grid' in your correspondence, should your comments be project specific.

We would like to thank you in anticipation of your active and meaningful contribution to the BA and public participation processes.

Geagte Belangstellende en/of Geaffekteerde Party,

BASIESE EVALUERINGS (BEs) VIR DIE BEOOGDE ONTWIKKELING VAN DIE DRIE (3) NETWERKVERBINDINGSINFRASTRUKTUURONTWIKKELINGS (SUBSTASIES EN KRAGLYNE) NABY NOUPOORT EN MIDDELBURG IN DIE NOORD- EN OOS-KAAPPROVINSIES

- **MOOI PLAATS SUBSTASIES EN KRAGLYN – (DO-verw. No.: Moet nog aangekondig word)**
- **WONDERHEUVEL SUBSTASIES EN KRAGLYN – (DO-verw. No.: Moet nog aangekondig word)**

• **PAARDE VALLEY SUBSTASIES EN KRAGLYN – (DO-verw. No.: Moet nog aangekondig word)**

Ons stel u graag in kennis dat SiVEST SA (Edms) Bpk aangestel is as die onafhanklike Omgewingsevalueringspraktisyn (OEP) om die Basiese Evalueerings- (BE) prosesse vir die bogenoemde voorgestelde projekte te onderneem.

Ons wil graag van hierdie geleentheid gebruik maak om u in te lig dat ingevolge die Nasionale Wet op Omgewingsbestuur (NEMA) (Wet No. 107 van 1998) (soos gewysig), sal die Konsep Basiese Evalueeringsverslae (KBEVs) vir die bogenoemde voorgestelde projekte vanaf **Maandag 10 Februarie 2020** tot **Woensdag 11 Maart 2020** (teen sluitingstyd) beskikbaar wees vir openbare kommentaar en insae. As u elektroniese kopie van die KBEVs (op CD) wil ontvang, moet u dit asseblief skriftelik by ons versoek. Kommentaar kan soos volg ingedien word:

Hlengiwe Ntuli

Posbus 2921, RIVONIA, 2128

Foon: (011) 798 0600

E-pos: sivest_ppp@sivest.co.za / hlengiwen@sivest.co.za / stephanj@sivest.co.za

Faks: (011) 803 7272

Gedrukte kopie van die KBEVs kan by die volgende openbare plekke nagegaan word:

| PLEK | VERSLAG / VERSLAE | STRAATADRES | TYE | KONTAKNOMMERS |
|--------------------------------------|-----------------------------------------------------------------------------------------|------------------------------------------|---------------------------------------------------------------|---------------|
| Noupoort Publieke Biblioteek | Mooi Plaats Substasie en Kraglyn KBEV | Shawstraat, Noupoort, 5950 | Maandae - Vrydae 10:00 - 13:00 13:45 - 16:30 | 049 843 1056 |
| Middelburg Publieke Biblioteek | Wonderheuvel Substasie en Kraglyn KBEV Paarde Valley Substasie en Kraglyn KBEV | Van Reenenstraat 47, Middelburg, 5900 | Maandae - Vrydae 09:00 - 16:30 | 049 802 1300 |

Die verslae, sowel as die meegaande aanhangsels, is ook beskikbaar op SiVEST se webwerf: <http://www.sivest.co.za/>, klik op 'Downloads' en soek dan vir die legger '15324 Umsobomvu PV and Grid'. Verwys asseblief 'Mooi Plaats / Wonderheuvel / Paarde Valley Grid' in u korrespondensie, indien u kommentaar spesifiek op die projek is.

Ons dank u byvoorbaat vir u aktiewe en betekenisvolle bydrae tot die BE en Openbare Deelnameprosesse.

Kind Regards,

Stephan Jacobs (B.Sc. (Hons) Environmental Management and Analysis)

Environmental Consultant / Visual Specialist

SiVEST Environmental Division

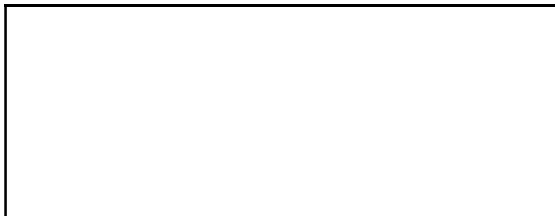

SiVEST is a Level 3 BBBEE Contributor

D +27 11 798 0677 | **T** +27 011 798 0600 **E** stephanj@sivest.co.za | **W** www.sivest.co.za

Engineering Consulting | Project Management | Environmental Consulting | Town & Regional Planning | Management Systems Consulting

Durban | Johannesburg | Pretoria | Pietermaritzburg | Richards Bay | Port Louis (Mauritius)

Disclaimer

The information contained in this communication from the sender is confidential. It is intended solely for use by the recipient and others authorized to receive it. If you are not the recipient, you are hereby notified that any disclosure, copying, distribution or taking action in relation of the contents of this information is strictly prohibited and may be unlawful.

This email has been scanned for viruses and malware, and automatically archived by **Mimecast SA (Pty) Ltd**, an innovator in Software as a Service (SaaS) for business. **Mimecast Unified Email Management ??? (UEM)** offers email continuity, security, archiving and compliance with all current legislation. To find out more, [contact Mimecast](#).

DISCLAIMER: The information contained in this email and its attachments is both confidential and subject to copyright. If you are not the intended recipient, you are hereby notified not to read, disclose copy or use the contents thereof in any manner whatsoever, but are kindly requested to notify the sender and delete it immediately. This e-mail message does not create any legally binding contract between Transnet SOC LTD and the recipient, unless the contrary is specifically stated. Statements and opinions expressed in e-mails may not represent those of Transnet SOC LTD. While Transnet will take reasonable precautions, it cannot give any guarantee or warrant that this email will be free of virus infections, errors, interception and, therefore, cannot be held liable for any loss or damages incurred by the recipient, as a result of any of the above-mentioned factors.

DISCLAIMER: The information contained in this email and its attachments is both confidential and subject to copyright. If you are not the intended recipient, you are hereby notified not to read, disclose copy or use the contents thereof in any manner whatsoever, but are kindly requested to notify the sender and delete it immediately. This e-mail message does not create any legally binding contract between Transnet SOC LTD and the recipient, unless the contrary is specifically stated. Statements and opinions expressed in e-mails may not represent those of Transnet SOC LTD. While Transnet will take reasonable precautions, it cannot give any guarantee or warrant that this email will be free of virus infections, errors, interception and, therefore, cannot be held liable for any loss or damages incurred by the recipient, as a result of any of the above-mentioned factors.

Stephan Jacobs

From: Mark Moodaley *Transnet Property PLZ <Mark.Moodaley@transnet.net>
Sent: Wednesday, 18 March 2020 2:39 PM
To: Stephan Jacobs
Cc: Thandeka Nohoyeka Transnet Property PLZ; sivist_PPP; Hlengiwe Ntuli; Liandra Scott-Shaw
Subject: RE: 15324 Three (3) Solar PV Energy Facilities and Grid Infrastructures near Noupoot and Middelburg: DBAR Comment Period Ending

Hi Stephan,

Many thanks for the reply.

Based on your reply our understanding of same is that the "Renewable Energy Application Sites" are essentially other projects with a 35km radius and does not form part of this application. To this end the comments from the Bloemfontein office would suffice.

Kind regards



Mark M Moodaley
Chief Property Technician
Transnet Property
Geo-Spatial: Central Region (Port Elizabeth)
+27 41 507 1319 +27 83 376 3024
+27 11 308 1308 +27 41 507 2884
mark.moodaley@transnet.net
www.transnet.net

From: Stephan Jacobs <StephanJ@sivest.co.za>
Sent: 18 March 2020 01:36 PM
To: Mark Moodaley *Transnet Property PLZ <Mark.Moodaley@transnet.net>
Cc: Thandeka Nohoyeka Transnet Property PLZ <Thandeka.Nohoyeka@transnet.net>; sivist_PPP <sivist_ppp@sivest.co.za>; Hlengiwe Ntuli <HlengiweN@sivest.co.za>; Liandra Scott-Shaw <LiandraS@sivest.co.za>
Subject: RE: 15324 Three (3) Solar PV Energy Facilities and Grid Infrastructures near Noupoot and Middelburg: DBAR Comment Period Ending

Hi Mark,

Not a problem. Noted, thanks for letting me know. That's actually why I thought I would forward you these comments (to be safe).

Noted, thanks. I thought it was for the Solar PV Application Sites. We take note that the Bloemfontein office's comment is correct with regards to these projects.

With regards to the map provided in the email below, this map shows the other Renewable Energy projects within a 35km radius from our projects. This is required as part of our cumulative impact assessment (part of EIA and BA processes). Our projects are the sites which are "striped" in the map below (Red, Blue and Orange striped sites in map below). The Substation sites (part of grid connection infrastructure BAs) are shown as the yellow boxes, while the overhead power line corridors (also part of grid connection infrastructure BAs) are shown as Blue lines.

KML files and locality maps for the Grid Connection Projects (Substations and power lines) as well as the Solar PV projects were sent to you on 13 march 2020 (see attached email).

I hope this information helps. Do not hesitate to contact me should you require further clarity in this regard.

Kind Regards,

Stephan Jacobs (*B.Sc. (Hons) Environmental Management and Analysis*)
Environmental Consultant / Visual Specialist
SIVEST Environmental Division



SIVEST is a Level 3 BBBEE Contributor

D +27 11 798 0677 | **T** +27 011 798 0600 | **M** +27 72 737 2114 **E** stephanj@sivest.co.za | **W** www.sivest.co.za

Engineering Consulting | Project Management | Environmental Consulting | Town & Regional Planning | Management Systems Consulting

Durban | Johannesburg | Pretoria | Pietermaritzburg | Richards Bay | Port Louis (Mauritius)

From: Mark Moodaley *Transnet Property PLZ [<mailto:Mark.Moodaley@transnet.net>]
Sent: Wednesday, 18 March 2020 12:35 PM
To: Stephan Jacobs <StephanJ@sivest.co.za>
Cc: Thandeka Nohoyeka Transnet Property PLZ <Thandeka.Nohoyeka@transnet.net>; sivest_PPP <sivest_ppp@sivest.co.za>; Hlengiwe Ntuli <HlengiweN@sivest.co.za>; Liandra Scott-Shaw <LiandraS@sivest.co.za>
Subject: RE: 15324 Three (3) Solar PV Energy Facilities and Grid Infrastructures near Noupoot and Middelburg: DBAR Comment Period Ending

Hi Stephan,

Thank you for the update. We were not made aware of the comment made by our Bloemfontein office but the comments are duly noted.

It is noted that the comments were provided for the "Solar PV Application Sites" in which case our Bloemfontein's office comment correct. We are however interested in the footprints of the "Renewable Energy Application Sites" labelled as Solar and Wind (Please see screen shot below). Would these sites form part of this application?

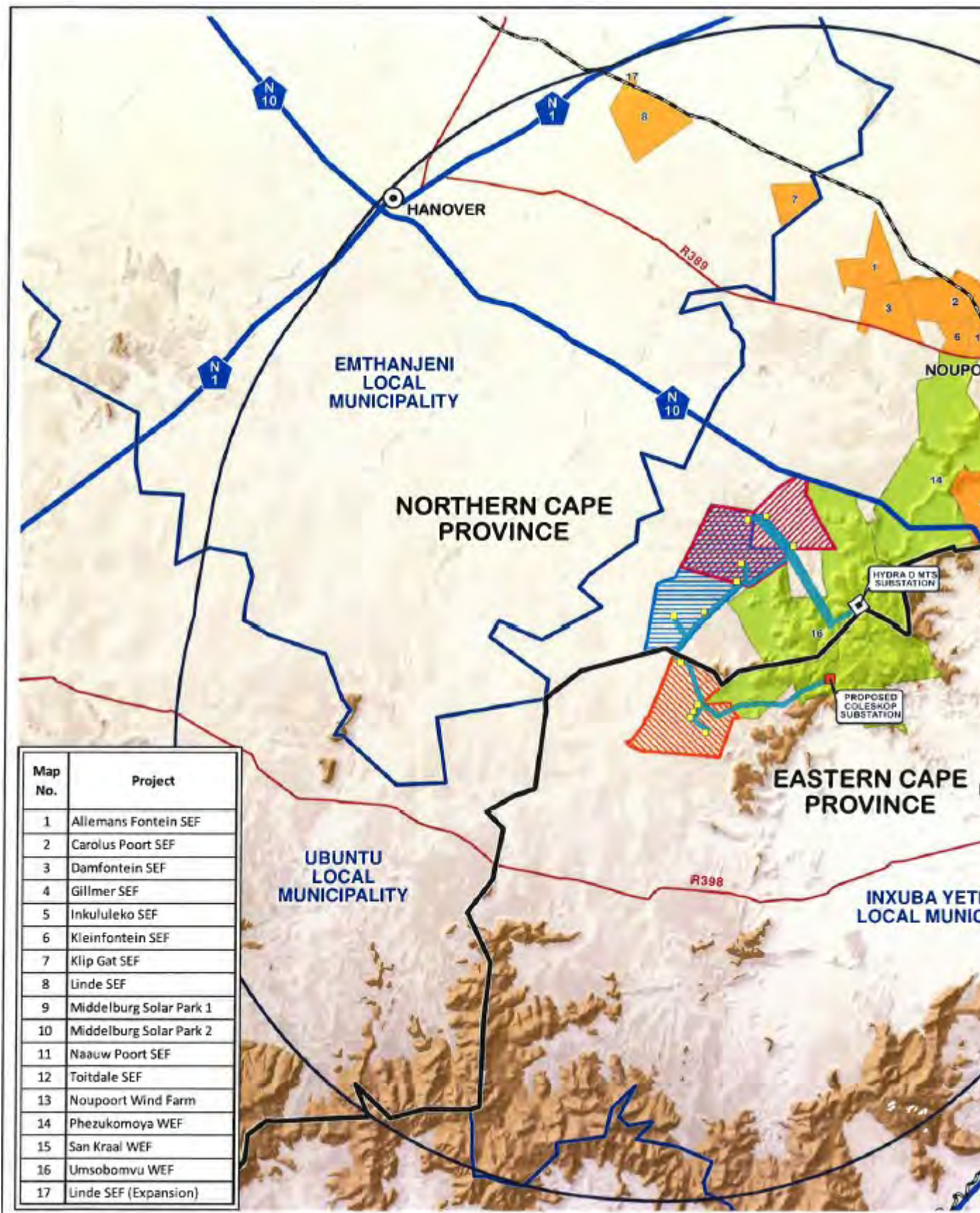

Kind regards



Mark M Moodaley
Chief Property Technician
Transnet Property
Geo-Spatial: Central Region (Port Elizabeth)
+27 41 507 1319 +27 83 376 3024
+27 11 308 1308 +27 41 507 2884
mark.moodaley@transnet.net
www.transnet.net

From: Stephan Jacobs <StephanJ@sivest.co.za>
Sent: 18 March 2020 10:49 AM
To: Mark Moodaley *Transnet Property PLZ <Mark.Moodaley@transnet.net>
Cc: Thandeka Nohoyeka Transnet Property PLZ <Thandeka.Nohoyeka@transnet.net>; sivest_PPP <sivest_ppp@sivest.co.za>; Hlengiwe Ntuli <HlengiweN@sivest.co.za>; Liandra Scott-Shaw <LiandraS@sivest.co.za>
Subject: RE: 15324 Three (3) Solar PV Energy Facilities and Grid Infrastructures near Noupoort and Middelburg: DBAR Comment Period Ending

Hi Mark,

Please ignore the email below. I sent this email by mistake before it was completed.

I wanted to inform you that we received a response from Zanoxolo Pama from Transnet when we sent locality maps for the three (3) proposed solar PV energy facilities (separate EIA processes) and grid projects (substations and power lines). It was stated that Transnet will NOT be affected by the proposal as the areas of interest are too far from any Transnet land (see attached email).

However, as mentioned, should you have any comments and should we receive these after we have submitted the Final BA Reports, we will forward them directly to the competent authority (namely the Department of Environment, Forestry and Fisheries - DEFF) for consideration.

Please do not hesitate to contact us should there be any issues or should you have any further queries.

Kind Regards,

Stephan Jacobs (B.Sc. (Hons) Environmental Management and Analysis)
Environmental Consultant / Visual Specialist
SIVEST Environmental Division



SIVEST is a Level 3 BBBEE Contributor

D +27 11 798 0677 | **T** +27 011 798 0600 | **M** +27 72 737 2114 **E** stephanj@sivest.co.za | **W** www.sivest.co.za

Engineering Consulting | Project Management | Environmental Consulting | Town & Regional Planning | Management Systems Consulting
Durban | Johannesburg | Pretoria | Pietermaritzburg | Richards Bay | Port Louis (Mauritius)

From: Stephan Jacobs
Sent: Wednesday, 18 March 2020 10:44 AM
To: 'Mark Moodaley *Transnet Property PLZ' <Mark.Moodaley@transnet.net>
Cc: Thandeka Nohoyeka Transnet Property PLZ <Thandeka.Nohoyeka@transnet.net>; sivist_PPP <sivist_ppp@sivest.co.za>; Hlengiwe Ntuli <HlengiweN@sivest.co.za>; Liandra Scott-Shaw <LiandraS@sivest.co.za>
Subject: RE: 15324 Three (3) Solar PV Energy Facilities and Grid Infrastructures near Noupoot and Middelburg: DBAR Comment Period Ending

Hi Mark,

Noted, thanks for the input. Just to let you know, we received a response from from Transnet for the three (3) proposed

Noted, thank you very much. As mentioned, should we receive your comments after we have submitted the Final BA Reports, we will forward them directly to the competent authority (namely the Department of Environment, Forestry and Fisheries - DEFF) for consideration.

Please do not hesitate to contact us should there be any issues or should you have any further queries.

Kind Regards,

Stephan Jacobs (B.Sc. (Hons) Environmental Management and Analysis)
Environmental Consultant / Visual Specialist
SiVEST Environmental Division



SiVEST is a Level 3 BBBEE Contributor

D +27 11 798 0677 | **T** +27 011 798 0600 | **M** +27 72 737 2114 **E** stephanj@sivest.co.za | **W** www.sivest.co.za

Engineering Consulting | Project Management | Environmental Consulting | Town & Regional Planning | Management Systems Consulting
Durban | Johannesburg | Pretoria | Pietermaritzburg | Richards Bay | Port Louis (Mauritius)

From: Mark Moodaley *Transnet Property PLZ [<mailto:Mark.Moodaley@transnet.net>]
Sent: Wednesday, 18 March 2020 10:09 AM
To: Stephan Jacobs <StephanJ@sivest.co.za>
Cc: Thandeka Nohoyeka Transnet Property PLZ <Thandeka.Nohoyeka@transnet.net>; sivist_PPP <sivist_ppp@sivest.co.za>; Hlengiwe Ntuli <HlengiweN@sivest.co.za>; Liandra Scott-Shaw <LiandraS@sivest.co.za>
Subject: RE: 15324 Three (3) Solar PV Energy Facilities and Grid Infrastructures near Noupoot and Middelburg: DBAR Comment Period Ending

Hi Stephan,

Thank you for the reply. Your comments are duly noted.

To put things into perspective, our department is essentially a support service and to this end our comments are provided to the land owner with Transnet who will then provide a formal reply to the applicant.

We will endeavour to ensure that our investigation and comments are prioritised and will advise the relevant land owner of the applicable deadline.

Kind regards



Mark M Moodaley
Chief Property Technician
Transnet Property
Geo-Spatial: Central Region (Port Elizabeth)

+27 41 507 1319 +27 83 376 3024
+27 11 308 1308 +27 41 507 2884
mark.moodaley@transnet.net
www.transnet.net

From: Stephan Jacobs <StephanJ@sivest.co.za>
Sent: 18 March 2020 09:54 AM
To: Mark Moodaley *Transnet Property PLZ <Mark.Moodaley@transnet.net>
Cc: Thandeka Nohoyeka Transnet Property PLZ <Thandeka.Nohoyeka@transnet.net>; sivest_PPP <sivest_ppp@sivest.co.za>; Hlengiwe Ntuli <HlengiweN@sivest.co.za>; Liandra Scott-Shaw <LiandraS@sivest.co.za>
Subject: RE: 15324 Three (3) Solar PV Energy Facilities and Grid Infrastructures near Noupoort and Middelburg: DBAR Comment Period Ending

Good Morning Mr Moodaley,

Not a problem, glad to be of assistance.

Noted, thank you for informing us. Can you indicate by when you will be able to provide comments? We have legislated timeframes to adhere to and cannot delay the submission of the Final BA Reports significantly as it would affect the timeframes. If possible, please can you submit comments by close of business on Friday 27 March 2020?

Otherwise we will forward your comments directly to the competent authority (namely the Department of Environment, Forestry and Fisheries - DEFF) for consideration once received.

Kind Regards,

Stephan Jacobs (B.Sc. (Hons) Environmental Management and Analysis)
Environmental Consultant / Visual Specialist
SIVEST Environmental Division



SIVEST is a Level 3 BBBEE Contributor

D +27 11 798 0677 | **T** +27 011 798 0600 | **M** +27 72 737 2114 **E** stephanj@sivest.co.za | **W** www.sivest.co.za

Engineering Consulting | Project Management | Environmental Consulting | Town & Regional Planning | Management Systems Consulting
Durban | Johannesburg | Pretoria | Pietermaritzburg | Richards Bay | Port Louis (Mauritius)

From: Mark Moodaley *Transnet Property PLZ [<mailto:Mark.Moodaley@transnet.net>]
Sent: Wednesday, 18 March 2020 9:46 AM
To: Stephan Jacobs <StephanJ@sivest.co.za>
Cc: Thandeka Nohoyeka Transnet Property PLZ <Thandeka.Nohoyeka@transnet.net>; sivist_PPP <sivist_ppp@sivest.co.za>; Hlengiwe Ntuli <HlengiweN@sivest.co.za>; Liandra Scott-Shaw <LiandraS@sivest.co.za>
Subject: RE: 15324 Three (3) Solar PV Energy Facilities and Grid Infrastructures near Noupoort and Middelburg: DBAR Comment Period Ending

Hi Stephanus,

Many thanks for your reply.

We will need additional time to provide comment as our findings will need distributed to the relevant land owners for an official reply.

Kind regards



From: Stephan Jacobs <StephanJ@sivest.co.za>
Sent: 13 March 2020 11:11 AM
To: Mark Moodaley *Transnet Property PLZ <Mark.Moodaley@transnet.net>
Cc: Thandeka Nohoyeka Transnet Property PLZ <Thandeka.Nohoyeka@transnet.net>; sivist_PPP <sivist_ppp@sivest.co.za>; Hlengiwe Ntuli <HlengiweN@sivest.co.za>; Liandra Scott-Shaw <LiandraS@sivest.co.za>
Subject: RE: 15324 Three (3) Solar PV Energy Facilities and Grid Infrastructures near Noupoort and Middelburg: DBAR Comment Period Ending
Importance: High

Good Morning Mr Moodaley,

I trust you are well.

The email below refers.

Thank you for your email. Apologies that the notice did not reach you timeously enough in order to provide supporting information to the relevant operating division for comment by 11 March 2020. Please be advised that SiVEST will only be submitting the Final Basic Assessments Reports (FBARs) for the three (3) grid projects (substations and power lines) at the end of March, therefore, we will provide you with additional time to comment. We can give you until the end of business day on Monday 23 March 2020 to provide comments in this regard. Would this be acceptable? Please advise should you require some more time.

As requested, please find attached KML files containing the data requested in your email below. These KMLs contain all the data requested below. SiVEST have also provided locality maps for the proposed solar PV and grid projects (substations and power lines), as this was also requested by Transnet (see attached email).

Please be advised that SiVEST will forward your comments with regards to the Solar , should you have any, to the competent authority (namely the DEA) for consideration.

We trust that you will find everything in order.

Please do not hesitate to contact us should there be any issues or should you have any further queries etc.

Kind Regards,

Stephan Jacobs (B.Sc. (Hons) Environmental Management and Analysis)
Environmental Consultant / Visual Specialist
SiVEST Environmental Division



SiVEST is a Level 3 BBBEE Contributor

D +27 11 798 0677 | **T** +27 011 798 0600 | **M** +27 72 737 2114 **E** stephanj@sivest.co.za | **W** www.sivest.co.za

Engineering Consulting | Project Management | Environmental Consulting | Town & Regional Planning | Management Systems Consulting

Durban | Johannesburg | Pretoria | Pietermaritzburg | Richards Bay | Port Louis (Mauritius)

From: Mark Moodaley *Transnet Property PLZ [<mailto:Mark.Moodaley@transnet.net>]

Sent: Tuesday, 10 March 2020 12:43 PM

To: sivest_PPP <sivest_ppp@sivest.co.za>

Cc: Thandeka Nohoyeka Transnet Property PLZ <Thandeka.Nohoyeka@transnet.net>

Subject: FW: 15324 Three (3) Solar PV Energy Facilities and Grid Infrastructures near Noupoort and Middelburg: DBAR Comment Period Ending

Importance: High

Good day,

The subject matter refers.

Kindly note that the notice did not reach us timeously enough for us to provide supporting information to the relevant operating division for comment by 11 March 2020 hence additional time will be required.

Further, it would be appreciated if the following data could be provide to us in CAD or Shape file format in order for us to determine what bearing (if any) this development will have on Transnet land:

1. Foot print of the three solar PV application sites.
2. The grid connection assessment corridors.
3. Proposed On-Site Substations.
4. Foot print of the renewable energy application sites (Solar and Wind).

Thanking you in anticipation.

Kind regards



Mark M Moodaley
Chief Property Technician
Transnet Property
Geo-Spatial: Central Region (Port Elizabeth)
+27 41 507 1319 +27 83 376 3024
+27 11 308 1308 +27 41 507 2884
mark.moodaley@transnet.net
www.transnet.net

From: Johannes Hanekom *Transnet Property CPT <Johannes.Hanekom@transnet.net>
Sent: 06 March 2020 02:56 PM
To: Mark Moodaley *Transnet Property PLZ <Mark.Moodaley@transnet.net>
Cc: Livhuwani Ndou Transnet Freight Rail JHB <Livhuwani.Ndou@transnet.net>; Burton Siljeur *Transnet Property CPT <Burton.Siljeur@transnet.net>
Subject: FW: 15324 Three (3) Solar PV Energy Facilities and Grid Infrastructures near Noupoot and Middelburg: DBAR Comment Period Ending
Importance: High

Good day Mark

Transnet land in the Western Region is not affected by this application.
Central Region office may need to investigate/ assist if they are affected or not.
Please find attached which has been downloaded, for your attention.

With thanks.

Regards



Jaco Hanekom
Senior Property Technician
Geo-Spatial: Western Region
Transnet Property
+27 21 449 4529
Johannes.Hanekom@Transnet.net
www.transnet.net

From: Livhuwani Ndou Transnet Freight Rail JHB
Sent: 04 March 2020 12:13 PM
To: Sam Fiff Transnet Freight Rail BLM; Norman Papenfus Transnet Freight Rail BLM; Johannes Hanekom *Transnet Property CPT; Andre Bodenstein *Transnet Property BLM
Cc: Zanele Manyathi Transnet Freight Rail JHB; Creselda Mangalana Transnet Freight Rail Johannesburg
Subject: FW: 15324 Three (3) Solar PV Energy Facilities and Grid Infrastructures near Noupoot and Middelburg: DBAR Comment Period Ending
Importance: High

Dear Colleagues,

Please review and comment on this proposal.

Kind regards,

Livhuwani

From: Ezekiel Monyamane Transnet Freight Rail JHB
Sent: 04 March 2020 08:31 AM

To: Livhuwani Ndou Transnet Freight Rail JHB <Livhuwani.Ndou@transnet.net>

Subject: FW: 15324 Three (3) Solar PV Energy Facilities and Grid Infrastructures near Noupoort and Middelburg:
DBAR Comment Period Ending

Importance: High

FYI

From: sivest_PPP [mailto:sivest_ppp@sivest.co.za]

Sent: 03 March 2020 04:28 PM

Cc: Stephan Jacobs; Liandra Scott-Shaw; 'Sheldon.vandrey@edf-re.co.za'

Subject: RE: 15324 Three (3) Solar PV Energy Facilities and Grid Infrastructures near Noupoort and Middelburg:
DBAR Comment Period Ending

Importance: High

Dear Interested and/or Affected Party (I&AP) / Stakeholder,

BASIC ASSESSMENTS (BAs) FOR THE PROPOSED DEVELOPMENT OF THE THREE (3) GRID CONNECTION INFRASTRUCTURE DEVELOPMENTS (SUBSTATIONS AND POWER LINES) NEAR NOUPOORT AND MIDDELBURG IN THE NORTHERN AND EASTERN CAPE PROVINCES

- Mooi Plaats Grid – (DEA Ref No: To be announced)
- Wonderheuvel Grid – (DEA Ref No: To be announced)
- Paarde Valley Grid – (DEA Ref No: To be announced)

Please note that the Draft Basic Assessment Reports (DBARs) for the above-mentioned projects were made available for public review and comment from **Monday the 10th of February 2020 to Wednesday the 11th of March 2020** (end of business day). The review and comment periods for the above-mentioned projects therefore end next week on **Wednesday the 11th of March 2020** (end of business day).

SiVEST therefore wish to remind you to submit comments for the above-mentioned projects (where required). If possible, please submit all comments before or by **Wednesday the 11th of March 2020** (end of business day).

Should you have any comments, please feel free to contact the public participation office at the details below:

SiVEST Environmental

PO Box 2921, RIVONIA, 2128

Phone: (011) 798 0600

E-mail: hengiwen@sivest.co.za / sivest_ppp@sivest.co.za

Fax: (011) 803 7272

We would like to thank you in anticipation of your active and meaningful contribution to the BA and public participation process.

Kind Regards,

Hlengiwe Ntuli

Projects Secretary and PPP Administrator

SiVEST





SIVEST is a Level 3 BBBEE Contributor

D +27 11 798 0690| **T** +27 11 798 0600 | **E** HlengiweN@sivest.co.za | **W** www.sivest.co.za
Engineering Consulting | Project Management | Environmental Consulting | Town & Regional Planning | Management Systems Consulting
Durban | Johannesburg | Pretoria | Pietermaritzburg | Richards Bay | Port Louis (Mauritius)

From: sivest_PPP
Sent: 10 February 2020 05:04 PM
Cc: Stephan Jacobs <StephanJ@sivest.co.za>; Liandra Scott-Shaw <LiandraS@sivest.co.za>; 'Sheldon.vandrey@edf-re.co.za' <Sheldon.vandrey@edf-re.co.za>
Subject: 15324 Three (3) Solar PV Energy Facilities and Grid Infrastructures near Noupoort and Middelburg: DBAR Comment Period Starting

Dear Interested and/or Affected Party (I&AP),

BASIC ASSESSMENTS (BAs) FOR THE PROPOSED DEVELOPMENT OF THE THREE (3) GRID CONNECTION INFRASTRUCTURE DEVELOPMENTS (SUBSTATIONS AND POWER LINES) NEAR NOUPOORT AND MIDDELBURG IN THE NORTHERN AND EASTERN CAPE PROVINCES

- **Mooi Plaats Grid – (DEA Ref No: To be announced)**
- **Wonderheuvel Grid – (DEA Ref No: To be announced)**
- **Paarde Valley Grid – (DEA Ref No: To be announced)**

Please note that SIVEST SA (Pty) Ltd has been appointed as the independent Environmental Assessment Practitioner (EAP) to undertake the Basic Assessment (BA) processes for the above-mentioned proposed projects.

We would like to take this opportunity to inform you that, in accordance with the National Environmental Management Act, 1998 (Act No. 107 of 1998) (NEMA) (as amended), the Draft Basic Assessment Reports (DBARs) for the above-mentioned proposed projects will be available for public comment and review as from **Monday the 10th of February 2020 to Wednesday the 11th of March 2020** (end of business day). Should you wish to receive an electronic copy of the DBARs (on CD), please forward your request in writing to us. Comments can be submitted to:

Hlengiwe Ntuli
PO Box 2921, RIVONIA, 2128
Phone: (011) 798 0600
E-mail: sivest_ppp@sivest.co.za / hlengiwen@sivest.co.za / stephanj@sivest.co.za
Fax: (011) 803 7272

Hard copies of the DBARs can be reviewed at the following public places:

| VENUE | REPORT(S) | STREET ADDRESS | HOURS | CONTACT NO |
|---------------------------|------------------------|----------------------------------------|------------------------------------------------------------|--------------|
| Noupoort Public Library | Mooi Plaats Grid DBAR | Shaw St, Noupoort, 5950 | Mondays - Fridays 10:00 - 13:00 13:45 - 16:30 | 049 843 1056 |
| Middelburg Public Library | Wonderheuvel Grid DBAR | 47 Van Reenen Street, Middelburg, 5900 | Mondays - Fridays 09:00 - 16:30 | 049 802 1300 |

The reports as well as the accompanying appendices are also available on SiVEST's website: <http://www.sivest.co.za/>, click on 'Downloads', then browse to the folder '15324 Umsobomvu PV and Grid'. Please reference 'Mooi Plaats / Wonderheuvel / Paarde Valley Grid' in your correspondence, should your comments be project specific.

We would like to thank you in anticipation of your active and meaningful contribution to the BA and public participation processes.

Geagte Belangstellende en/of Geaffekteerde Party,

BASIESE EVALUERINGS (BEs) VIR DIE BEOOGDE ONTWIKKELING VAN DIE DRIE (3) NETWERKVERBINDINGSINFRASTRUKTUURONTWIKKELINGS (SUBSTASIES EN KRAGLYNE) NABY NOUPOORT EN MIDDELBURG IN DIE NOORD- EN OOS-KAAPROVINSIES

- **MOOI PLAATS SUBSTASIES EN KRAGLYN – (DO-verw. No.: Moet nog aangekondig word)**
- **WONDERHEUVEL SUBSTASIES EN KRAGLYN – (DO-verw. No.: Moet nog aangekondig word)**
- **PAARDE VALLEY SUBSTASIES EN KRAGLYN – (DO-verw. No.: Moet nog aangekondig word)**

Ons stel u graag in kennis dat SiVEST SA (Edms) Bpk aangestel is as die onafhanklike Omgewingsevalueringpraktisyn (OEP) om die Basiese Evaluering- (BE) prosesse vir die bogenoemde voorgestelde projekte te onderneem.

Ons wil graag van hierdie geleentheid gebruik maak om u in te lig dat ingevolge die Nasionale Wet op Omgewingsbestuur (NEMA) (Wet No. 107 van 1998) (soos gewysig), sal die Konsep Basiese Evalueringverslae (KBEVs) vir die bogenoemde voorgestelde projekte vanaf **Maandag 10 Februarie 2020** tot **Woensdag 11 Maart 2020** (teen sluitingstyd) beskikbaar wees vir openbare kommentaar en insae. As u elektroniese kopie van die KBEVs (op CD) wil ontvang, moet u dit asseblief skriftelik by ons versoek. Kommentaar kan soos volg ingedien word:

Hlengiwe Ntuli

Posbus 2921, RIVONIA, 2128

Foon: (011) 798 0600

E-pos: sivest_ppp@sivest.co.za / hlengiw@zivest.co.za / stephanj@sivest.co.za

Faks: (011) 803 7272

Gedrukte kopie van die KBEVs kan by die volgende openbare plekke nagegaan word:

| PLEK | VERSLAG / VERSLAE | STRAATADRES | TYE | KONTAKNOMMERS |
|--------------------------------------|-----------------------------------------------------------------------------------------|------------------------------------------|---------------------------------------------------------------------|---------------|
| Noupoort Publieke Biblioteek | Mooi Plaats Substasie en Kraglyn KBEV | Shawstraat, Noupoort, 5950 | Maandae - Vrydae 10:00 - 13:00 13:45 - 16:30 | 049 843 1056 |
| Middelburg Publieke Biblioteek | Wonderheuvel Substasie en Kraglyn KBEV Paarde Valley Substasie en Kraglyn KBEV | Van Reenenstraat 47, Middelburg, 5900 | Maandae - Vrydae 09:00 - 16:30 | 049 802 1300 |

Die verslae, sowel as die meegaande aanhangsels, is ook beskikbaar op SiVEST se webwerf: <http://www.sivest.co.za/>, klik op 'Downloads' en soek dan vir die legger '15324 Umsobomvu PV and Grid'. Verwys asseblief 'Mooi Plaats / Wonderheuvel / Paarde Valley Grid' in u korrespondensie, indien u kommentaar spesifiek op die projek is.

Ons dank u byvoorbeeld vir u aktiewe en betekenisvolle bydrae tot die BE en Openbare Deelnameprosesse.

immediately. This e-mail message does not create any legally binding contract between Transnet SOC LTD and the recipient, unless the contrary is specifically stated. Statements and opinions expressed in e-mails may not represent those of Transnet SOC LTD. While Transnet will take reasonable precautions, it cannot give any guarantee or warrant that this email will be free of virus infections, errors, interception and, therefore, cannot be held liable for any loss or damages incurred by the recipient, as a result of any of the above-mentioned factors.

DISCLAIMER: The information contained in this email and its attachments is both confidential and subject to copyright. If you are not the intended recipient, you are hereby notified not to read, disclose copy or use the contents thereof in any manner whatsoever, but are kindly requested to notify the sender and delete it immediately. This e-mail message does not create any legally binding contract between Transnet SOC LTD and the recipient, unless the contrary is specifically stated. Statements and opinions expressed in e-mails may not represent those of Transnet SOC LTD. While Transnet will take reasonable precautions, it cannot give any guarantee or warrant that this email will be free of virus infections, errors, interception and, therefore, cannot be held liable for any loss or damages incurred by the recipient, as a result of any of the above-mentioned factors.

DISCLAIMER: The information contained in this email and its attachments is both confidential and subject to copyright. If you are not the intended recipient, you are hereby notified not to read, disclose copy or use the contents thereof in any manner whatsoever, but are kindly requested to notify the sender and delete it immediately. This e-mail message does not create any legally binding contract between Transnet SOC LTD and the recipient, unless the contrary is specifically stated. Statements and opinions expressed in e-mails may not represent those of Transnet SOC LTD. While Transnet will take reasonable precautions, it cannot give any guarantee or warrant that this email will be free of virus infections, errors, interception and, therefore, cannot be held liable for any loss or damages incurred by the recipient, as a result of any of the above-mentioned factors.

Eskom requirements for work in or near Eskom servitudes.

1. Eskom's rights and services must be acknowledged and respected at all times.
2. Eskom shall at all times retain unobstructed access to and egress from its servitudes.
3. Eskom's consent does not relieve the developer from obtaining the necessary statutory, land owner or municipal approvals.
4. Any cost incurred by Eskom as a result of non-compliance to any relevant environmental legislation will be charged to the developer.
5. If Eskom has to incur any expenditure in order to comply with statutory clearances or other regulations as a result of the developer's activities or because of the presence of his equipment or installation within the servitude restriction area, the developer shall pay such costs to Eskom on demand.
6. The use of explosives of any type within 500 metres of Eskom's services shall only occur with Eskom's previous written permission. If such permission is granted the developer must give at least fourteen working days prior notice of the commencement of blasting. This allows time for arrangements to be made for supervision and/or precautionary instructions to be issued in terms of the blasting process. It is advisable to make application separately in this regard.
7. Changes in ground level may not infringe statutory ground to conductor clearances or statutory visibility clearances. After any changes in ground level, the surface shall be rehabilitated and stabilised so as to prevent erosion. The measures taken shall be to Eskom's satisfaction.
8. Eskom shall not be liable for the death of or injury to any person or for the loss of or damage to any property whether as a result of the encroachment or of the use of the servitude area by the developer, his/her agent, contractors, employees, successors in title, and assignees. The developer indemnifies Eskom against loss, claims or damages including claims pertaining to consequential damages by third parties and whether as a result of damage to or interruption of or interference with Eskom's services or apparatus or otherwise. Eskom will not be held responsible for damage to the developer's equipment.
9. No mechanical equipment, including mechanical excavators or high lifting machinery, shall be used in the vicinity of Eskom's apparatus and/or services, without prior written permission having been granted by Eskom. If such permission is granted the developer must give at least seven working days' notice prior to the commencement of work. This allows time for arrangements to be made for supervision and/or precautionary instructions to be issued by the relevant Eskom Manager

Note: Where and electrical outage is required, at least fourteen work days are required to arrange it.

10. Eskom's rights and duties in the servitude shall be accepted as having prior right at all times and shall not be obstructed or interfered with.
11. Under no circumstances shall rubble, earth or other material be dumped within the servitude restriction area. The developer shall maintain the area concerned to Eskom's satisfaction. The developer shall be liable to Eskom for the cost of any remedial action which has to be carried out by Eskom.
12. The clearances between Eskom's live electrical equipment and the proposed construction work shall be observed as stipulated by *Regulation 15 of the Electrical Machinery Regulations of the Occupational Health and Safety Act, 1993 (Act 85 of 1993)*.
13. Equipment shall be regarded electrically live and therefore dangerous at all times.
14. In spite of the restrictions stipulated by Regulation 15 of the Electrical Machinery Regulations of the Occupational Health and Safety Act, 1993 (Act 85 of 1993), as an additional safety precaution, Eskom will not approve the erection of houses, or structures occupied or frequented by human beings, under the power lines or within the servitude restriction area.
15. Eskom may stipulate any additional requirements to highlight any possible exposure to Customers or Public to coming into contact or be exposed to any dangers of Eskom plant.
16. It is required of the developer to familiarise himself with all safety hazards related to Electrical plant.
17. Any third party servitudes encroaching on Eskom servitudes shall be registered against Eskom's title deed at the developer's own cost. If such a servitude is brought into being, its existence should be endorsed on the Eskom servitude deed concerned, while the third party's servitude deed must also include the rights of the affected Eskom servitude.

John Geeringh (Pr Sci Nat)

Senior Consultant Environmental Management
Eskom GC: Land Development

| | | |
|-----------------------------------------------------------------------------------|-------------|-------------------|
|  | SCOT | Technology |
|-----------------------------------------------------------------------------------|-------------|-------------------|

Title: **Renewable Energy Generation Plant Setbacks to Eskom Infrastructure** Unique Identifier: **240-65559775**

Alternative Reference Number: **N/A**

Area of Applicability: **Power Line Engineering**

Documentation Type: **Guideline**

Revision: **1**

Total Pages: **9**

Next Review Date: **N/A**

Disclosure Classification: **CONTROLLED DISCLOSURE**

Compiled by



J W Chetty
Mechanical Engineer

Date: *23/11/2018*

Approved by



B Ntshunsha
Chief Engineer (Lines)

Date: *24/11/2018*

Authorised by



R A Vajeth
Snr Manager (Lines) and SCOT/SCI Chairperson

Date: *16/11/2018*

CONTENTS

| | Page |
|--------------------------------------------|----------|
| EXECUTIVE SUMMARY | 3 |
| 1. INTRODUCTION | 4 |
| 2. SUPPORTING CLAUSES | 4 |
| 2.1 SCOPE | 4 |
| 2.1.1 Purpose | 4 |
| 2.1.2 Applicability | 5 |
| 2.2 NORMATIVE/INFORMATIVE REFERENCES | 5 |
| 2.2.1 Normative | 5 |
| 2.2.2 Informative | 5 |
| 2.3 DEFINITIONS | 5 |
| 2.3.1 Disclosure Classification | 6 |
| 2.4 ABBREVIATIONS | 6 |
| 2.5 ROLES AND RESPONSIBILITIES | 6 |
| 2.6 PROCESS FOR MONITORING | 6 |
| 2.7 RELATED/SUPPORTING DOCUMENTS | 6 |
| 3. DOCUMENT CONTENT | 6 |
| 3.1 INTERNATIONAL SETBACK COMPARISON | 6 |
| 3.2 ESKOM APPROACH FOR WIND FARMS | 7 |
| 4. AUTHORISATION | 8 |
| 5. REVISIONS | 8 |
| 6. DEVELOPMENT TEAM | 9 |

FIGURES

| | |
|----------------------------------------------|---|
| Figure 1: Horizontal Axis Wind Turbine | 8 |
|----------------------------------------------|---|

CONTROLLED DISCLOSURE

When downloaded from the EDMS, this document is uncontrolled and the responsibility rests with the user to ensure it is in line with the authorised version on the system.

EXECUTIVE SUMMARY

In recent decades, the use of wind turbines, concentrated solar plants and photovoltaic plants have been on the increase as it serves as an abundant source of energy. This document specifies setbacks for wind turbines and the reasons for these setbacks from infrastructure as well as setbacks for concentrated solar plants and photovoltaic plants. Setbacks for wind turbines employed in other countries were compared and a general setback to be used by Eskom was suggested for use with wind turbines and other renewable energy generation plants.

CONTROLLED DISCLOSURE

When downloaded from the EDMS, this document is uncontrolled and the responsibility rests with the user to ensure it is in line with the authorised version on the system.

1. INTRODUCTION

During the last few decades, a large amount of wind turbines have been installed in wind farms to accommodate for the large demand of energy and depleting fossil fuels. Wind is one of the most abundant sources of renewable energy. Wind turbines harness the energy of this renewable resource for integration in electricity networks. The extraction of wind energy is its primary function and thus the aerodynamics of the wind turbine is important. There are many different types of wind turbines which will all exhibit different wind flow characteristics. The most common wind turbine used commercially is the Horizontal Axis Wind Turbine. Wind flow characteristics of this turbine are important to analyse as it may have an effect on surrounding infrastructure.

Wind turbines also cause large turbulence downwind that may affect existing infrastructure. Debris or parts of the turbine blade, in the case of a failure, may be tossed behind the turbine and may lead to damage of infrastructure in the wake path.

This document outlines the minimum distances that need to be introduced between a wind turbine and Eskom infrastructure to ensure that debris and / or turbulence would not negatively impact on the infrastructure.

Safety distances of wind turbines from other structures as implemented by other countries were also considered and the reasons for their selection were noted.

Concentrated solar plants and photovoltaic plants setbacks away from substations were also to be considered to prevent restricting possible power line access routes to the substation.

2. SUPPORTING CLAUSES

2.1 SCOPE

This document provides guidance on the safe distance that a wind turbine should be located from any Eskom power line or substation. The document specifies setback distances for transmission lines (220 kV to 765 kV), distribution lines (6.6 kV to 132 kV) and all Eskom substations. Setbacks for concentrated solar plants and photovoltaic plants are also specified away from substations.

2.1.1 Purpose

Setbacks for wind turbines and power lines / substations are required for various reasons. These include possible catastrophic failure of the turbine blade that may release fragments and which may be thrown onto nearby power lines that may result in damage with associated unplanned outages. Turbulence behind the turbine may affect helicopter flight during routine Eskom live line maintenance and

CONTROLLED DISCLOSURE

When downloaded from the EDMS, this document is uncontrolled and the responsibility rests with the user to ensure it is in line with the authorised version on the system.

inspections that may lead to safety risk of the aircraft / personnel. Concentrated solar plants and photovoltaic plants setback away from substations were required to prevent substations from being boxed in by these renewable generation plants limiting line route access to the substations.

2.1.2 Applicability

This document is applicable to the siting of all new and existing wind turbines, concentrated solar plants and photovoltaic plants near power lines and substations.

2.2 NORMATIVE/INFORMATIVE REFERENCES

2.2.1 Normative

1. <http://www.envir.ee/orb.aw/class=file/action=preview/id=1170403/Hiiumaa+turbulence+impact+EMD.pdf>.
2. <http://www.energy.ca.gov/2005publications/CEC-500-2005-184/CEC-500-2005-184.PDF>
3. <http://www.adamscountywind.com/Revised%20Site/Windmills/Adams%20County%20Ordinance/Adams%20County%20Wind%20Ord.htm>
4. http://www.dsireusa.org/incentives/incentive.cfm?Incentive_Code=PA11R&RE=1&EE=1
5. <http://www.wind-watch.org/documents/european-setbacks-minimum-distance-between-wind-turbines-and-habitations/>
6. <http://www.publications.parliament.uk/pa/ld201011/ldbills/017/11017.1-i.html>
7. http://www.caw.ca/assets/pdf/Turbine_Safety_Report.pdf
8. Rogers J, Slegers N, Costello M. (2011) A method for defining wind turbine setback standards. Wind energy 10.1002/we.468

2.2.2 Informative

None

2.3 DEFINITIONS

| Definition | Description |
|------------|-----------------------------------------------------------------------------------------------------------|
| Setback | The minimum distance between a wind turbine and boundary line/dwelling/road/infrastructure/servitude etc. |
| Flicker | Effect caused when rotating wind turbine blades periodically cast shadows |
| Tip Height | The total height of the wind turbine ie. Hub height plus half rotor diameter (see Figure1) |

CONTROLLED DISCLOSURE

When downloaded from the EDMS, this document is uncontrolled and the responsibility rests with the user to ensure it is in line with the authorised version on the system.

2.3.1 Disclosure Classification

Controlled disclosure: controlled disclosure to external parties (either enforced by law, or discretionary).

2.4 ABBREVIATIONS

| Abbreviation | Description |
|--------------|-------------|
| None | |

2.5 ROLES AND RESPONSIBILITIES

All personnel involved in the positioning wind turbines, concentrated solar plants and photovoltaic plants near power lines/substations must follow the setbacks outlined in this guideline.

2.6 PROCESS FOR MONITORING

Approval by Eskom in writing.

2.7 RELATED/SUPPORTING DOCUMENTS

None

3. DOCUMENT CONTENT

3.1 INTERNATIONAL SETBACK COMPARISON

Wind Turbine setbacks employed by various countries were considered. It was found that setbacks were determined for various reasons that include noise, flicker, turbine blade failure and wind effects. The distances (setbacks) varied based on these factors and were influenced by the type of infrastructure

Wind turbine setbacks varied for roads, power lines, dwellings, buildings and property and it was noted that the largest setbacks were employed for reasons of noise and flicker related issues [1-7]. Very few countries specified setbacks for power lines.

The literature survey [1-7], yielded information about studies and experiments were conducted to determine the distance that a broken fragment from a wind turbine might be thrown. Even though of low probability of hitting a power line [5.0×10^{-5}]^[8], the distances recorded were significant [750m]^[8]

Setbacks were thus introduced to prevent any damage to Eskom infrastructure.

CONTROLLED DISCLOSURE

When downloaded from the EDMS, this document is uncontrolled and the responsibility rests with the user to ensure it is in line with the authorised version on the system.

Wind turbines may also cause changes in wind patterns with turbulent effects behind the hub. These factors dictate the wind turbine setbacks specified in this document.

Concentrated solar plants and photovoltaic plants also can limit access into the substation for power lines of all voltages. A setback distance must therefore be employed to prevent the substation from being boxed in by these generation plants. These setback distances are specified in this document.

3.2 ESKOM REQUIRED SETBACKS

A formal application must be sent to and accepted by Eskom if any of the below mentioned setback distances are infringed upon:

- Eskom requires a setback distance of 3 times the tip height of the wind turbine from the edge of the closest Eskom servitude (including vacant servitudes) for transmission lines (220kV to 765kV) and Substations.
- Eskom requires a setback distance of 1 times the tip height of the wind turbine from the edge of the closest Eskom servitude (including vacant servitudes) for distribution lines (66 kV to 132 kV) and Substations.
- An application must be sent to Eskom regarding any proposed wind turbine, concentrated solar plants and photovoltaic activity within a 5 km radius of a substation for Eskom to comment on the application.
- Where concentrated solar plants and photovoltaic structures fall within a 2 km radius of the closest point of a transmission or distribution substation (66kV to 765kV), Eskom should be applied to for approval in writing during the planning phase of such plant or structures.
- Applicants must not position any wind turbine in the line of site between and two Eskom Radio Telecommunication masts. It must be proven that Eskom radio telecommunication systems (mainly microwave systems) will not be affected in any way by wind turbines.
- If the position or size of any turbine changes and subsequently infringes on any of the above stated setbacks, an application must be sent through to Eskom as per the point mentioned above.

CONTROLLED DISCLOSURE

When downloaded from the EDMS, this document is uncontrolled and the responsibility rests with the user to ensure it is in line with the authorised version on the system.

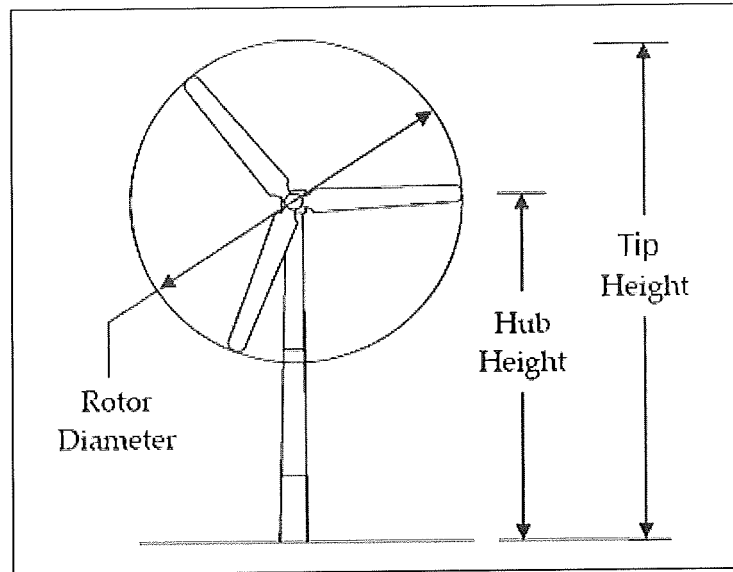

Figure 1: Horizontal Axis Wind Turbine ^[2]

4. AUTHORISATION

This document has been seen and accepted by:

| Name & Surname | Designation |
|------------------|-----------------------------|
| V Naidoo | Chief Engineer |
| Dr P H Pretorius | Electrical Specialist |
| J Geeringh | Snr Consultant Environ Mngt |
| B Haridass | Snr Consultant Engineer |
| R A Vajeth | Acting Snr Manager (Lines) |

5. REVISIONS

| Date | Rev. | Compiler | Remarks |
|---------------|------|------------|---------------------------------------------------------------------------------------------|
| November 2013 | 0 | J W Chetty | First Publication - No renewable energy generation plant setback specification in existence |
| October 2018 | 1 | JW Chetty | Modification to sub-section 3.2 to provide more clarity for application procedure |

CONTROLLED DISCLOSURE

When downloaded from the EDMS, this document is uncontrolled and the responsibility rests with the user to ensure it is in line with the authorised version on the system.

6. DEVELOPMENT TEAM

The following people were involved in the development of this document:

Jonathan W Chetty (Mechanical Engineer)

Vivendhra Naidoo (Chief Engineer)

Dr Pieter H Pretorius (Electrical Specialist)

John Geeringh (Snr Consultant Environ Mngt)

Bharat Haridass (Snr Consultant Engineer)

Riaz A Vajeth (Acting Snr Manager (Lines))

CONTROLLED DISCLOSURE

When downloaded from the EDMS, this document is uncontrolled and the responsibility rests with the user to ensure it is in line with the authorised version on the system.

Stephan Jacobs

From: Nondwe Mdekazi <Nondwe.Mdekazi@dedea.gov.za>
Sent: Wednesday, 26 February 2020 12:14 PM
To: Stephan Jacobs
Subject: RE: BA Processes for construction of two (2) grid infrastructure developments (substations and power lines) near Middelburg in the Eastern Cape Province

Good Day

Email received cannot download or access he files

Regards
Nondwe

From: Stephan Jacobs <StephanJ@sivest.co.za>
Sent: Tuesday, 25 February 2020 10:38
To: Nondwe Mdekazi <ilitha09@gmail.com>; Nondwe Mdekazi <Nondwe.Mdekazi@dedea.gov.za>
Cc: Liandra Scott-Shaw <LiandraS@sivest.co.za>; Hlengiwe Ntuli <HlengiweN@sivest.co.za>
Subject: FW: BA Processes for construction of two (2) grid infrastructure developments (substations and power lines) near Middelburg in the Eastern Cape Province
Importance: High

Good Morning Nondwe,

I trust you are well.

The email below and attachment refers.

I sent this email to you last week Thursday (20 February 2020), however, I have not yet received a response.

Can you please confirm whether you received this email as well as the attachments?

Please do not hesitate to contact me should there be any issues or should you have any queries in this regard.

Your earliest possible response will be greatly appreciated.

Kind Regards,

Stephan Jacobs (*B.Sc. (Hons) Environmental Management and Analysis*)
Environmental Consultant / Visual Specialist
SiVEST Environmental Division



SiVEST is a Level 3 BBBEE Contributor

From: Stephan Jacobs [<mailto:stephanj@sivest.co.za>]

Sent: Thursday, 20 February 2020 10:55 AM

To: Nondwe.Mdekazi@dedea.gov.za; ilitha09@gmail.com

Cc: Liandra Scott-Shaw <LiandraS@sivest.co.za>; sivest_PPP <sivest_ppp@sivest.co.za>; Hlengiwe Ntuli <HlengiweN@sivest.co.za>

Subject: BA Processes for construction of two (2) grid infrastructure developments (substations and power lines) near Middelburg in the Eastern Cape Province

I'm using Mimecast to share large files with you. Please see the attached instructions.

Dear Nondwe,

- **BASIC ASSESSMENT (EIA) FOR THE PROPOSED DEVELOPMENT OF THE WONDERHEUVEL ON-SITE ESKOM SUBSTATION, ESKOM COLLECTOR SUBSTATION AND ASSOCIATED 132KV POWER LINE NEAR NOUPOORT AND MIDDELBURG IN THE NORTHERN AND EASTERN CAPE PROVINCES (WONDERHEUVEL GRID)**
- **BASIC ASSESSMENT (EIA) FOR THE PROPOSED DEVELOPMENT OF THE PAARDE VALLEY ON-SITE ESKOM SUBSTATIONS, ESKOM COLLECTOR SUBSTATION AND ASSOCIATED 132KV POWER LINE NEAR NOUPOORT AND MIDDELBURG IN THE NORTHERN AND EASTERN CAPE PROVINCES (PAARDE VALLEY GRID)**

- NEW APPLICATIONS FOR ENVIRONMENTAL AUTHORISATION (EA)

SiVEST has been appointed as the independent Environmental Assessment Practitioner (EAP) to undertake the Basic Assessment (EIA) processes for the proposed development of the above-mentioned grid infrastructure developments (on-site and collector substations and 132kV overhead power lines) near Middelburg in the Eastern Cape Province.

The above-mentioned proposed developments are located near the town of Middelburg in the Inxuba Yethemba Local Municipality within the Chris Hani District Municipality of the Eastern Cape Province.

The Application for Environmental Authorisation (EA) for the above-mentioned proposed developments were submitted to the Competent Authority (namely the National Department of Environment, Forestry and Fisheries - DEFF) on Thursday 13 February 2020. The DEFF's application form states that a copy of the application must be copied to the relevant Provincial Environmental Department(s) and thus we are also sending you a copy.

As such, please find herewith attached an electronic copies of the Applications for EA for the above-mentioned proposed developments. All appendices have been attached to the PDF copies of the application forms which are attached to this email.

Please do not hesitate to contact us should there be any issues or should you have any queries in this regard.

Kind Regards,

Stephan Jacobs

SiVEST Environmental Division

011 798 0600

072 737 2114

Disclaimer

The information contained in this communication from the sender is confidential. It is intended solely for use by the recipient and others authorized to receive it. If you are not the recipient, you are hereby notified that any disclosure, copying, distribution or taking action in relation of the contents of this information is strictly prohibited and may be unlawful.

This email has been scanned for viruses and malware, and automatically archived by **Mimecast SA (Pty) Ltd**, an innovator in Software as a Service (SaaS) for business. **Mimecast Unified Email Management ??? (UEM)** offers email continuity, security, archiving and compliance with all current legislation. To find out more, [contact Mimecast](#).

Stephan Jacobs

From: Nondwe Mdekazi <ilitha09@gmail.com>
Sent: Wednesday, 26 February 2020 12:12 PM
To: Stephan Jacobs
Subject: Re: FW: BA Processes for construction of two (2) grid infrastructure developments (substations and power lines) near Middelburg in the Eastern Cape Province

Good Day

email received cannot download or access the files

Regards
Nondwe

On Tue, Feb 25, 2020 at 10:37 AM Stephan Jacobs <StephanJ@sivest.co.za> wrote:

Good Morning Nondwe,

-

I trust you are well.

-

The email below and attachment refers.

-

I sent this email to you last week Thursday (20 February 2020), however, I have not yet received a response.

-

Can you please confirm whether you received this email as well as the attachments?

-

Please do not hesitate to contact me should there be any issues or should you have any queries in this regard.

-

Your earliest possible response will be greatly appreciated.

-

Kind Regards,

-

Stephan Jacobs (B.Sc. (Hons) Environmental Management and Analysis)

Environmental Consultant / Visual Specialist



SiVEST is a Level 3 BBBEE Contributor

D +27 11 798 0677 | **T** +27 011 798 0600 | **M** +27 72 737 2114 **E** stephanj@sivest.co.za | **W** www.sivest.co.za

Engineering Consulting | Project Management | Environmental Consulting | Town & Regional Planning | Management Systems Consulting

Durban | Johannesburg | Pretoria | Pietermaritzburg | Richards Bay | Port Louis (Mauritius)

From: Stephan Jacobs [mailto:stephanj@sivest.co.za]

Sent: Thursday, 20 February 2020 10:55 AM

To: Nondwe.Mdekazi@dedea.gov.za; ilitha09@gmail.com

Cc: Liandra Scott-Shaw <LiandraS@sivest.co.za>; sivest_PPP <sivest_ppp@sivest.co.za>; Hlengiwe Ntuli <HlengiweN@sivest.co.za>

Subject: BA Processes for construction of two (2) grid infrastructure developments (substations and power lines) near Middelburg in the Eastern Cape Province

I'm using Mimecast to share large files with you. Please see the attached instructions.

Dear Nondwe,

- **BASIC ASSESSMENT (EIA) FOR THE PROPOSED DEVELOPMENT OF THE WONDERHEUVEL ON-SITE ESKOM SUBSTATION, ESKOM COLLECTOR SUBSTATION AND ASSOCIATED 132KV POWER LINE NEAR NOUPOORT AND**

**MIDDELBURG IN THE NORTHERN AND EASTERN CAPE PROVINCES
(WONDERHEUVEL GRID)**

- **BASIC ASSESSMENT (EIA) FOR THE PROPOSED DEVELOPMENT OF THE PAARDE VALLEY ON-SITE ESKOM SUBSTATIONS, ESKOM COLLECTOR SUBSTATION AND ASSOCIATED 132KV POWER LINE NEAR NOUPOORT AND MIDDELBURG IN THE NORTHERN AND EASTERN CAPE PROVINCES (PAARDE VALLEY GRID)**

-
- NEW APPLICATIONS FOR ENVIRONMENTAL AUTHORISATION (EA)

-
SiVEST has been appointed as the independent Environmental Assessment Practitioner (EAP) to undertake the Basic Assessment (EIA) processes for the proposed development of the above-mentioned grid infrastructure developments (on-site and collector substations and 132kV overhead power lines) near Middelburg in the Eastern Cape Province.

The above-mentioned proposed developments are located near the town of Middelburg in the Inxuba Yethemba Local Municipality within the Chris Hani District Municipality of the Eastern Cape Province.

The Application for Environmental Authorisation (EA) for the above-mentioned proposed developments were submitted to the Competent Authority (namely the National Department of Environment, Forestry and Fisheries - DEFF) on Thursday 13 February 2020. The DEFF's application form states that a copy of the application must be copied to the relevant Provincial Environmental Department(s) and thus we are also sending you a copy.

As such, please find herewith attached an electronic copies of the Applications for EA for the above-mentioned proposed developments. All appendices have been attached to the PDF copies of the application forms which are attached to this email.

Please do not hesitate to contact us should there be any issues or should you have any queries in this regard.

-
Kind Regards,

Stephan Jacobs

SiVEST Environmental Division

011 798 0600

072 737 2114

Disclaimer

The information contained in this communication from the sender is confidential. It is intended solely for use by the recipient and others authorized to receive it. If you are not the recipient, you are hereby notified that any disclosure, copying, distribution or taking action in relation of the contents of this information is strictly prohibited and may be unlawful.

This email has been scanned for viruses and malware, and automatically archived by **Mimecast SA (Pty) Ltd**, an innovator in

Stephan Jacobs

From: Nondwe Mdekazi <Nondwe.Mdekazi@dedea.gov.za>
Sent: Thursday, 27 February 2020 9:58 AM
To: Stephan Jacobs
Cc: Sisipho Mahomba
Subject: RE: FW: BA Processes for construction of two (2) grid infrastructure developments (substations and power lines) near Middelburg in the Eastern Cape Province

Good Day Stephan

Email received and the documents were downloaded successfully.

Thank You
Nondwe

From: Stephan Jacobs <StephanJ@sivest.co.za>
Sent: Thursday, 27 February 2020 09:02
To: Nondwe Mdekazi <ilitha09@gmail.com>; Nondwe Mdekazi <Nondwe.Mdekazi@dedea.gov.za>
Cc: Liandra Scott-Shaw <LiandraS@sivest.co.za>; Hlengiwe Ntuli <HlengiweN@sivest.co.za>; sivest_PPP <sivest_ppp@sivest.co.za>
Subject: RE: FW: BA Processes for construction of two (2) grid infrastructure developments (substations and power lines) near Middelburg in the Eastern Cape Province
Importance: High

Good Morning Nondwe,

I trust you are well.

The emails below regarding the Wonderheuvel ([14/12/16/3/3/1/2134](#)) and Paarde Valley ([14/12/16/3/3/1/2133](#)) Substations and 132kV overhead power lines near Noupoort and Middelburg in the Northern and Eastern Cape Province refers.

Please see below for the WeTransfer link to download the application forms for the above-mentioned proposed projects.

<https://we.tl/t-c9RYvTtAwr>

You mentioned that you could not download the files in the previous email which I sent. I hope this works.

Please kindly confirm receipt of this email (reply to stephanj@sivest.co.za) and let me know if you have any issues downloading the files.

Kind Regards,

Stephan Jacobs (*B.Sc. (Hons) Environmental Management and Analysis*)
Environmental Consultant / Visual Specialist
SiVEST Environmental Division





SiVEST is a Level 3 BBBEE Contributor

D +27 11 798 0677 | **T** +27 011 798 0600 | **M** +27 72 737 2114 **E** stephanj@sivest.co.za | **W** www.sivest.co.za

Engineering Consulting | Project Management | Environmental Consulting | Town & Regional Planning | Management Systems Consulting

Durban | Johannesburg | Pretoria | Pietermaritzburg | Richards Bay | Port Louis (Mauritius)

From: Nondwe Mdekazi [<mailto:ilitha09@gmail.com>]

Sent: Wednesday, 26 February 2020 12:12 PM

To: Stephan Jacobs <StephanJ@sivest.co.za>

Subject: Re: FW: BA Processes for construction of two (2) grid infrastructure developments (substations and power lines) near Middelburg in the Eastern Cape Province

Good Day

email received cannot download or access the files

Regards
Nondwe

On Tue, Feb 25, 2020 at 10:37 AM Stephan Jacobs <StephanJ@sivest.co.za> wrote:

Good Morning Nondwe,

-

I trust you are well.

-

The email below and attachment refers.

-

I sent this email to you last week Thursday (20 February 2020), however, I have not yet received a response.

-

Can you please confirm whether you received this email as well as the attachments?

-

Please do not hesitate to contact me should there be any issues or should you have any queries in this regard.

-

Your earliest possible response will be greatly appreciated.

-

Kind Regards,

-
Stephan Jacobs (B.Sc. (Hons) Environmental Management and Analysis)

Environmental Consultant / Visual Specialist

SiVEST Environmental Division



-
SiVEST is a Level 3 BBBEE Contributor

-
D +27 11 798 0677 | T +27 011 798 0600 | M +27 72 737 2114 E stephanj@sivest.co.za | W www.sivest.co.za

Engineering Consulting | Project Management | Environmental Consulting | Town & Regional Planning | Management Systems Consulting

Durban | Johannesburg | Pretoria | Pietermaritzburg | Richards Bay | Port Louis (Mauritius)

-
From: Stephan Jacobs [mailto:stephanj@sivest.co.za]

Sent: Thursday, 20 February 2020 10:55 AM

To: Nondwe.Mdekazi@dedea.gov.za; ilitha09@gmail.com

Cc: Liandra Scott-Shaw <LiandraS@sivest.co.za>; sivest_PPP <sivest_ppp@sivest.co.za>; Hlengiwe Ntuli <HlengiweN@sivest.co.za>

Subject: BA Processes for construction of two (2) grid infrastructure developments (substations and power lines) near Middelburg in the Eastern Cape Province

-
I'm using Mimecast to share large files with you. Please see the attached instructions.

Dear Nondwe,

-

- **BASIC ASSESSMENT (EIA) FOR THE PROPOSED DEVELOPMENT OF THE WONDERHEUVEL ON-SITE ESKOM SUBSTATION, ESKOM COLLECTOR SUBSTATION AND ASSOCIATED 132KV POWER LINE NEAR NOUPOORT AND MIDDELBURG IN THE NORTHERN AND EASTERN CAPE PROVINCES (WONDERHEUVEL GRID)**
- **BASIC ASSESSMENT (EIA) FOR THE PROPOSED DEVELOPMENT OF THE PAARDE VALLEY ON-SITE ESKOM SUBSTATIONS, ESKOM COLLECTOR SUBSTATION AND ASSOCIATED 132KV POWER LINE NEAR NOUPOORT AND MIDDELBURG IN THE NORTHERN AND EASTERN CAPE PROVINCES (PAARDE VALLEY GRID)**

-

- NEW APPLICATIONS FOR ENVIRONMENTAL AUTHORISATION (EA)

-

SiVEST has been appointed as the independent Environmental Assessment Practitioner (EAP) to undertake the Basic Assessment (EIA) processes for the proposed development of the above-mentioned grid infrastructure developments (on-site and collector substations and 132kV overhead power lines) near Middelburg in the Eastern Cape Province.

The above-mentioned proposed developments are located near the town of Middelburg in the Inxuba Yethemba Local Municipality within the Chris Hani District Municipality of the Eastern Cape Province.

The Application for Environmental Authorisation (EA) for the above-mentioned proposed developments were submitted to the Competent Authority (namely the National Department of Environment, Forestry and Fisheries - DEFF) on Thursday 13 February 2020. The DEFF's application form states that a copy of the application must be copied to the relevant Provincial Environmental Department(s) and thus we are also sending you a copy.

As such, please find herewith attached an electronic copies of the Applications for EA for the above-mentioned proposed developments. All appendices have been attached to the PDF copies of the application forms which are attached to this email.

Please do not hesitate to contact us should there be any issues or should you have any queries in this regard.

-

Kind Regards,

Stephan Jacobs

SiVEST Environmental Division

011 798 0600

072 737 2114



**Appendix 7D2
Correspondence
To Authorities**

Stephan Jacobs

From: Stephan Jacobs
Sent: Thursday, 06 June 2019 5:06 PM
To: 'Phillip Hine'
Cc: Andrea Gibb; Hlengiwe Ntuli
Subject: RE: Request for Assistance with Notice of Intent Form Template and Provincial Authority Contacts

Follow Up Flag: Follow up
Flag Status: Flagged

Good Afternoon Mr Hine,

Thank you very much for your response.

Noted, thank you for clarifying. We will make use of the South African Heritage Resources Information System (SAHRIS) as suggested.

Thank you for the contact details for the respective provincial departments. We will make sure to contact them.

Thank for your assistance in this regard. It is greatly appreciated.

Kind Regards,

Stephan Jacobs (*B.Sc. (Hons) Environmental Management and Analysis*)
Environmental Consultant / Visual Specialist
SiVEST Environmental Division



SiVEST is a Level 3 BBBEE Contributor

D +27 11 798 0677 | **T** +27 011 798 0600 | **M** +27 72 737 2114 **E** stephanj@sivest.co.za | **W** www.sivest.co.za

Engineering Consulting | Project Management | Environmental Consulting | Town & Regional Planning | Management Systems Consulting

Durban | Johannesburg | Pretoria | Pietermaritzburg | Richards Bay | Port Louis (Mauritius)

From: Phillip Hine [mailto:phine@sahra.org.za]
Sent: Thursday, 06 June 2019 3:09 PM
To: Stephan Jacobs <StephanJ@sivest.co.za>
Cc: Andrea Gibb <AndreaG@sivest.co.za>; Hlengiwe Ntuli <HlengiweN@sivest.co.za>
Subject: RE: Request for Assistance with Notice of Intent Form Template and Provincial Authority Contacts

Dear Mr Jacobs,

SAHRA does not have a Notification of Intent to Develop form. Please make use of the South African Heritage Resources Information System, <https://sahris.sahra.org.za/> when lodging an application with SAHRA.

For Eastern Cape please contact:

Africa Maxongo
Heritage Officer: Built Environment
043 6422811
nmaxongo@ecphra.org.za
"Dept of Public Works Complex
Corner of Amalinda and Scholl Road
Cambridge, East London 5206"

For Northern Cape please contact:

Ratha Timothy
0538312537
ratha.timothy@gmail.com

Kind Regards,

From: Stephan Jacobs <StephanJ@sivest.co.za>
Sent: 06 June 2019 02:09 PM
To: Phillip Hine <phine@sahra.org.za>
Cc: Andrea Gibb <AndreaG@sivest.co.za>; Hlengiwe Ntuli <HlengiweN@sivest.co.za>
Subject: FW: Request for Assistance with Notice of Intent Form Template and Provincial Authority Contacts
Importance: High

Good Afternoon Mr Hine,

The email below refers.

I sent this email to Natasha Higgitt but received an out of office message stating that we should contact you for any urgent matters.

Could you perhaps assist with this?

Please do not hesitate to contact me should you have any queries or should you wish to discuss this.

Kind Regards,

Stephan Jacobs (B.Sc. (Hons) Environmental Management and Analysis)
Environmental Consultant / Visual Specialist
SiVEST Environmental Division



SiVEST is a Level 3 BBBEE Contributor

D +27 11 798 0677 | **T** +27 011 798 0600 | **M** +27 72 737 2114 **E** stephanj@sivest.co.za | **W** www.sivest.co.za

Engineering Consulting | Project Management | Environmental Consulting | Town & Regional Planning | Management Systems Consulting

Durban | Johannesburg | Pretoria | Pietermaritzburg | Richards Bay | Port Louis (Mauritius)

From: Stephan Jacobs
Sent: Thursday, 06 June 2019 2:05 PM
To: 'Natasha Higgitt' <nhiggitt@sahra.org.za>
Cc: Andrea Gibb <AndreaG@sivest.co.za>; Hlengiwe Ntuli <HlengiweN@sivest.co.za>
Subject: Request for Assistance with Notice of Intent Form Template and Provincial Authority Contacts
Importance: High

Good Afternoon Ms/Mrs Higgitt,

I trust you are well.

SIVEST are in the process of compiling DEA application forms for EIA processes which we are planning on undertaking for Renewable Energy (RE) projects in the Northern and Eastern Cape provinces and came across the following statement:

"If Section 38 of the National Heritage Resources Act (Act No. 25 of 1999) is applicable to your proposed development, you are requested to submit the Notice of Intent form to the relevant SAHRA or a Provincial Heritage Resources Authority and attach a copy to this form."

In light of this, does SAHRA perhaps have a Notice of Intent Form Template which we could make use of, or know where we can find one? We have only ever encountered this for Heritage Western Cape (HWC) and thus are not certain where to find a template of this.

Also, can you please confirm who the Northern Cape and Eastern Cape Provincial Heritage Resources Authorities would be?

I did some research and found that the provincial authority for the EC is the Eastern Cape Provincial Heritage Resources Agency (ECPHRA). Is this correct? For the Northern Cape Province, Ngwao Boswa Kapa Bokone (commonly known as 'Boswa') seems to be the provincial heritage authority. Could you kindly please confirm whether this is correct or if all heritage related matters in the Northern Cape should go straight to SAHRA?

Your assistance will be greatly appreciated.

Do not hesitate to contact me should you have any queries or should you wish to discuss this.

Kind Regards,

Stephan Jacobs (*B.Sc. (Hons) Environmental Management and Analysis*)
Environmental Consultant / Visual Specialist
SiVEST Environmental Division



SiVEST is a Level 3 BBBEE Contributor

D +27 11 798 0677 | **T** +27 011 798 0600 | **M** +27 72 737 2114 **E** stephanj@sivest.co.za | **W** www.sivest.co.za

Engineering Consulting | Project Management | Environmental Consulting | Town & Regional Planning | Management Systems Consulting

Durban | Johannesburg | Pretoria | Pietermaritzburg | Richards Bay | Port Louis (Mauritius)

Disclaimer

The information contained in this communication from the sender is confidential. It is intended solely for use by the recipient and others authorized to receive it. If you are not the recipient, you are hereby notified that any disclosure, copying, distribution or taking action in relation of the contents of this information is strictly prohibited and may be unlawful.

This email has been scanned for viruses and malware, and automatically archived by **Mimecast SA (Pty) Ltd**, an innovator in Software as a Service (SaaS) for business. **Mimecast Unified Email Management ??? (UEM)** offers email continuity, security, archiving and compliance with all current legislation. To find out more, [contact Mimecast](#).

Phillip Hine

Acting Manager: APM

South African Heritage Resources Agency
- A nation united through heritage -

T: +27 21 4624502 /8652 or +27 21 202 8652| C:+27 83 793 3852| F:+27 21 462 4509
E: PHine@sahra.org.za | 111 Harrington Street | Cape Town |

www.sahra.org.za



an agency of the
Department of Arts and Culture

OUR VALUES: Accountability, Teamwork & co-operation, Respect, Transparency, Service Excellency, Integrity & Ethics, Professionalism, Accessibility, Communication & Trust.

BREAK THE CORRUPTION CHAIN
REPORT FRAUD & CORRUPTION: 0800 701 701



an agency of the
Department of Arts and Culture



Stephan Jacobs

From: Stephan Jacobs
Sent: Friday, 07 June 2019 2:05 PM
To: 'Natasha Higgitt'
Cc: Andrea Gibb; Hlengiwe Ntuli
Subject: RE: Request for Assistance with Notice of Intent Form Template and Provincial Authority Contacts

Follow Up Flag: Follow up
Flag Status: Flagged

Good Afternoon Ms/Mrs Higgitt,

Thank you very much for your response.

The information provided in the email below is noted and greatly appreciated. We will proceed as suggested.

Thank you very much for your assistance. This has been very helpful.

Kind Regards,

Stephan Jacobs (B.Sc. (Hons) Environmental Management and Analysis)
Environmental Consultant / Visual Specialist
SiVEST Environmental Division



SiVEST is a Level 3 BBBEE Contributor

D +27 11 798 0677 | **T** +27 011 798 0600 | **M** +27 72 737 2114 **E** stephanj@sivest.co.za | **W** www.sivest.co.za

Engineering Consulting | Project Management | Environmental Consulting | Town & Regional Planning | Management Systems Consulting
Durban | Johannesburg | Pretoria | Pietermaritzburg | Richards Bay | Port Louis (Mauritius)

From: Natasha Higgitt [mailto:nhiggitt@sahra.org.za]
Sent: Friday, 07 June 2019 11:38 AM
To: Stephan Jacobs <StephanJ@sivest.co.za>
Cc: Andrea Gibb <AndreaG@sivest.co.za>; Hlengiwe Ntuli <HlengiweN@sivest.co.za>
Subject: RE: Request for Assistance with Notice of Intent Form Template and Provincial Authority Contacts

Good morning,

With regards to the section 38 development application process, only developments that are applied for in terms of section 38(1) of the NRHA require that the relevant Heritage Resources Authority is notified at the earliest phase via a NID document. HWC has a form, however, if an application to SAHRA is submitted via SAHRIS, the SAHRIS application acts as a NID document. Other documents such as project motivation and map etc. can be uploaded as additional documents.

If the application is being conducted in terms of section 38(8) of the NHRA, then no NID is required as 38(1) does not apply when a 38(8) process is undertaken. Here we require the BID or announcement letter, the draft BAR and appendices, or the draft scoping with appendices, and draft EIA with appendices to provide comments.

With regards to the Northern Cape Provincial Heritage Resources Authority (<http://www.nbkb.org.za/>), the NCPHRA does not have the authority to provide comments on section 38 application with the exception that if a structure as defined and protected by section 34 is impacted, then the NCPHRA must be consulted for comments. All section 38(1) and 38(8) cases for the Northern Cape are processed by SAHRA via SAHRIS.

The Eastern Cape Provincial Heritage Resources Authority has been assessed to be competent to perform all function of the NHRA and therefore all section 38(1) and 38(8) application in the EC are process by the ECPHRA. They do not use SAHRIS and must be contacted directly. Please see the contact details for Sello Mokhanya (smokhanya@ecphra.org.za).

I hope this is helpful.

Kind regards,

From: Stephan Jacobs <StephanJ@sivest.co.za>
Sent: Thursday, June 06, 2019 2:05 PM
To: Natasha Higgitt <nhiggitt@sahra.org.za>
Cc: Andrea Gibb <AndreaG@sivest.co.za>; Hlengiwe Ntuli <HlengiweN@sivest.co.za>
Subject: Request for Assistance with Notice of Intent Form Template and Provincial Authority Contacts
Importance: High

Good Afternoon Ms/Mrs Higgitt,

I trust you are well.

SiVEST are in the process of compiling DEA application forms for EIA processes which we are planning on undertaking for Renewable Energy (RE) projects in the Northern and Eastern Cape provinces and came across the following statement:

"If Section 38 of the National Heritage Resources Act (Act No. 25 of 1999) is applicable to your proposed development, you are requested to submit the Notice of Intent form to the relevant SAHRA or a Provincial Heritage Resources Authority and attach a copy to this form."

In light of this, does SAHRA perhaps have a Notice of Intent Form Template which we could make use of, or know where we can find one? We have only ever encountered this for Heritage Western Cape (HWC) and thus are not certain where to find a template of this.

Also, can you please confirm who the Northern Cape and Eastern Cape Provincial Heritage Resources Authorities would be?

I did some research and found that the provincial authority for the EC is the Eastern Cape Provincial Heritage Resources Agency (ECPHRA). Is this correct? For the Northern Cape Province, Ngwao Boswa Kapa Bokone (commonly known as 'Boswa') seems to be the provincial heritage authority. Could you kindly please confirm whether this is correct or if all heritage related matters in the Northern Cape should go straight to SAHRA?

Your assistance will be greatly appreciated.

Do not hesitate to contact me should you have any queries or should you wish to discuss this.

Kind Regards,

Stephan Jacobs (B.Sc. (Hons) Environmental Management and Analysis)

Environmental Consultant / Visual Specialist
SiVEST Environmental Division



SiVEST is a Level 3 BBBEE Contributor

D +27 11 798 0677 | **T** +27 011 798 0600 | **M** +27 72 737 2114 **E** stephanj@sivest.co.za | **W** www.sivest.co.za

Engineering Consulting | Project Management | Environmental Consulting | Town & Regional Planning | Management Systems Consulting

Durban | Johannesburg | Pretoria | Pietermaritzburg | Richards Bay | Port Louis (Mauritius)

Disclaimer

The information contained in this communication from the sender is confidential. It is intended solely for use by the recipient and others authorized to receive it. If you are not the recipient, you are hereby notified that any disclosure, copying, distribution or taking action in relation of the contents of this information is strictly prohibited and may be unlawful.

This email has been scanned for viruses and malware, and automatically archived by **Mimecast SA (Pty) Ltd**, an innovator in Software as a Service (SaaS) for business. **Mimecast Unified Email Management ??? (UEM)** offers email continuity, security, archiving and compliance with all current legislation. To find out more, [contact Mimecast](#).

Natasha Higgitt

Heritage Officer: Archaeology, Palaeontology and Meteorites Unit

South African Heritage Resources Agency
- A nation united through heritage -

T: +27 21 462 4502/ 8660 | **C:**+27 82 507 0378| **F:**+27 21 462 4509
E: nhiggitt@sahra.org.za | 111 Harrington Street | Cape Town |

www.sahra.org.za



an agency of the
Department of Arts and Culture

OUR VALUES: Accountability, Teamwork & co-operation, Respect, Transparency, Service Excellency, Integrity & Ethics, Professionalism, Accessibility, Communication & Trust.

BREAK THE CORRUPTION CHAIN
REPORT FRAUD & CORRUPTION: 0800 701 701



an agency of the
Department of Arts and Culture

UNMASK THE CORRUPT



Stephan Jacobs

From: Stephan Jacobs
Sent: Thursday, 30 January 2020 10:27 AM
To: 'Natasha Higgitt'; sivest_PPP
Cc: Liandra Scott-Shaw; 'Sheldon.vandrey@edf-re.co.za'; Hlengiwe Ntuli
Subject: RE: Umsobomvu Power Lines and Substations near Noupoot and Middelburg – BID Notification

Importance: High

Good Morning Natasha,

I trust you are well.

The email below refers.

Please be advised that SiVEST will create the relevant case applications via the South African Heritage Resources Information System (SAHRIS) once the respective Draft Basic Assessment Reports (DBARs) and Application Forms have been submitted to the competent authority (namely the Department of Environment, Forestry and Fisheries - DEFF). SiVEST will upload all relevant documentation and will also ensure that the status of the cases are changed from DRAFT to SUBMITTED. SiVEST will notify you once this has been done.

We thank you for your feedback in this regard. Please do not hesitate to contact us should there be any issues in this regard.

Kind Regards,

Stephan Jacobs (*B.Sc. (Hons) Environmental Management and Analysis*)
Environmental Consultant / Visual Specialist
SiVEST Environmental Division



SiVEST is a Level 3 BBBEE Contributor

D +27 11 798 0677 | **T** +27 011 798 0600 | **M** +27 72 737 2114 **E** stephanj@sivest.co.za | **W** www.sivest.co.za

Engineering Consulting | Project Management | Environmental Consulting | Town & Regional Planning | Management Systems Consulting

Durban | Johannesburg | Pretoria | Pietermaritzburg | Richards Bay | Port Louis (Mauritius)

From: Natasha Higgitt [mailto:nhiggitt@sahra.org.za]
Sent: Wednesday, 29 January 2020 8:34 AM
To: sivest_PPP <sivest_ppp@sivest.co.za>
Cc: Stephan Jacobs <StephanJ@sivest.co.za>; Liandra Scott-Shaw <LiandraS@sivest.co.za>; 'Sheldon.vandrey@edf-re.co.za' <Sheldon.vandrey@edf-re.co.za>
Subject: RE: Umsobomvu Power Lines and Substations near Noupoot and Middelburg – BID Notification

Good morning,

Please note that all development applications are processed via our online portal, the South African Heritage Resources Information System (SAHRIS) found at the following link: <http://sahra.org.za/sahris/>. We do not accept emailed, posted, hardcopy, faxed, website links or DropBox links as official submissions.

Please create an application on SAHRIS and upload all documents pertaining to the Environmental Authorisation Application Process. As per section 38(8) of the National Heritage Resources Act, Act 25 of 1999 (NHRA), an assessment of heritage resources must form part of the process and the assessment must comply with section 38(3) of the NHRA.

Once all documents including all appendices are uploaded to the case application, please ensure that the status of the case is changed from DRAFT to SUBMITTED. Please ensure that all documents produced as part of the EA process are submitted as part of the application, and are submitted to SAHRA at the beginning of the Public Review periods. Once all these documents have been uploaded, I will be able to issue an informed comment as per section 38(4) and 38(8) of the NHRA.

From: sivest_PPP <sivest_ppp@sivest.co.za>
Sent: Tuesday, 28 January 2020 15:44
Cc: Stephan Jacobs <StephanJ@sivest.co.za>; Liandra Scott-Shaw <LiandraS@sivest.co.za>; 'Sheldon.vandrey@edf-re.co.za' <Sheldon.vandrey@edf-re.co.za>
Subject: Umsobomvu Power Lines and Substations near Noupoot and Middelburg – BID Notification

Dear Interested and/or Affected Party (I&AP) / Stakeholder,

Please find attached for your attention.
Please do not hesitate to contact us should you have any queries in this regard.”

Geagte Belangstellende en/of Geaffekteerde Party / Belanghebbende,

Vind asseblief aangeheg vir u aandag.
Moet asseblief nie huiwer om ons te kontak indien u enige navrae in hierdie verband het nie.

Kind Regards,
Stephan Jacobs (B.Sc. (Hons) Environmental Management and Analysis)
Environmental Consultant / Visual Specialist
SiVEST Environmental Division



SiVEST is a Level 3 BBBEE Contributor

D +27 11 798 0677 | T +27 011 798 0600 E stephanj@sivest.co.za | W www.sivest.co.za

Disclaimer

The information contained in this communication from the sender is confidential. It is intended solely for use by the recipient and others authorized to receive it. If you are not the recipient, you are hereby notified that any disclosure, copying, distribution or taking action in relation of the contents of this information is strictly prohibited and may be unlawful.

This email has been scanned for viruses and malware, and automatically archived by **Mimecast SA (Pty) Ltd**, an innovator in Software as a Service (SaaS) for business. **Mimecast Unified Email Management (UEM)** offers email continuity, security, archiving and compliance with all current legislation. To find out more, [contact Mimecast](#).

Natasha Higgitt

Heritage Officer: Archaeology, Palaeontology and Meteorites Unit

South African Heritage Resources Agency

- *A nation united through heritage* -

T: +27 21 462 4502/ 8660 | C:+27 82 507 0378 | F:+27 21 462 4509

E: nhiggitt@sahra.org.za | 111 Harrington Street | Cape Town |

www.sahra.org.za



an agency of the
Department of Arts and Culture

OUR VALUES: Accountability, Teamwork & co-operation, Respect, Transparency, Service Excellency, Integrity & Ethics, Professionalism, Accessibility, Communication & Trust.

BREAK THE CORRUPTION CHAIN
REPORT FRAUD & CORRUPTION: 0800 701 701



an agency of the
Department of Arts and Culture



Stephan Jacobs

From: Stephan Jacobs
Sent: Monday, 03 February 2020 12:55 PM
To: 'John Geeringh'
Subject: RE: 15324 Three (3) grid connection projects (substations and power lines) near Noupoort and Middelburg: KMLs of proposed power line routes and substation sites

Pleasure Mr Geeringh. Please do not hesitate to contact us should there be any issues or should you have any queries in this regard.

From: John Geeringh [mailto:GeerinJH@eskom.co.za]
Sent: Monday, 03 February 2020 12:49 PM
To: Stephan Jacobs <StephanJ@sivest.co.za>
Subject: RE: 15324 Three (3) grid connection projects (substations and power lines) near Noupoort and Middelburg: KMLs of proposed power line routes and substation sites

Thanks
John



From: Stephan Jacobs [mailto:StephanJ@sivest.co.za]
Sent: 03 February 2020 12:15 PM
To: John Geeringh
Cc: Liandra Scott-Shaw; Hlengiwe Ntuli; Kerry Schwartz; Sheldon Vandrey
Subject: RE: 15324 Three (3) grid connection projects (substations and power lines) near Noupoort and Middelburg: KMLs of proposed power line routes and substation sites
Importance: High

Good Afternoon Mr Geeringh,

I trust you are well.

The Basic Assessment (BA) processes for the proposed Mooi Plaats, Wonderheuvel and Paarde Valley grid connection developments (substation and overhead power lines) near Noupoort and Middelburg in the Northern and Eastern Cape Provinces refer. These proposed developments form part of the greater Umsobomvu PV project (which also includes the Mooi Plaats – [14/12/16/3/3/2/1134](#), Wonderheuvel - [14/12/16/3/3/2/1135](#) and Paarde Valley - [14/12/16/3/3/2/1136](#) Solar PV Energy Facilities).

As requested in the email below, please find attached KML files of the proposed grid connections for each project, along with the affected properties.

These attached KMLs show all alternatives for the proposed substation sites and overhead power line corridor routes. However, based on the result of the comparative assessment of alternatives for the respective projects, the following alternatives are preferred:

Mooi Plaats Grid:

- Grid Connection Option 1a (132kV overhead power line route);
- Substation 1a (Northern Collector Substation); and
- Substation 2 (On-site Substation).

Wonderheuvel Grid:

- Grid Connection Option 3 (132kV overhead power line route);
- Substation 4a (Central Collector Substation); and
- Substation 4b (On-site Substation).

Paarde Valley Grid:

- Grid Connection Option 2a (132kV overhead power line route);
- Substation 5 (On-site Substation);
- Substation 6a (Southern Collector Substation) and
- Substation 7a (On-site Substation).

It should be noted that the substation sites are intrinsically linked to the grid connection infrastructure alternatives. The locations for the on-site and collector substation sites being proposed have been informed by the grid connection infrastructure alternatives which have been chosen as 'preferred' by the respective specialists. Please see attached PDF document (project description) explaining how the respective grid connection infrastructure alternatives work.

For **Mooi Plaats**, Grid Connection Option 1a has been selected as the preferred grid connection infrastructure alternative and thus Substation 1a (Northern Collector) and Substation 2 (On-site) are being proposed, as these are intrinsically linked to this grid connection infrastructure alternative.

For **Wonderheuvel**, Grid Connection Option 3 has been selected as the preferred grid connection infrastructure alternative and thus Substation 4a (Central Collector) and Substation 4b (On-site) are being proposed, as these are intrinsically linked to this grid connection infrastructure alternative.

For **Paarde Valley**, Grid Connection Option 2a has been selected as the preferred grid connection infrastructure alternative and thus Substation 5 (On-site), Substation 6a (Southern Collector) and Substation 7a (On-site) are being proposed, as these are intrinsically linked to this grid connection infrastructure alternative.

The substation site alternatives being proposed as part of the BA application also align with the preferences for the substation sites associated with the proposed Mooi Plaats, Wonderheuvel and Paarde Valley Solar PV Energy Facility EIAs [proposed substations include an Eskom portion and an Independent Power Producer (IPP) portion, hence the substations have been included in the solar PV energy facility EIAs and in the grid infrastructure BAs to allow for handover to Eskom].

The information above has been explained in the Draft Basic Assessment Reports (DBARs), which SiVEST are planning on submitting on Friday 07 February 2020. You will receive a notification regarding the availability of the DBARs, once they have been submitted.

I trust you will find everything is in order.

Please do not hesitate to contact us should there be any issues or should you have any queries in this regard.

Kind Regards,

Stephan Jacobs (B.Sc. (Hons) Environmental Management and Analysis)

Environmental Consultant / Visual Specialist

SiVEST Environmental Division





SiVEST is a Level 3 BBBEE Contributor

D +27 11 798 0677 | **T** +27 011 798 0600 | **M** +27 72 737 2114 **E** stephanj@sivest.co.za | **W** www.sivest.co.za

Engineering Consulting | Project Management | Environmental Consulting | Town & Regional Planning | Management Systems Consulting

Durban | Johannesburg | Pretoria | Pietermaritzburg | Richards Bay | Port Louis (Mauritius)

From: John Geeringh [<mailto:GeerinJH@eskom.co.za>]

Sent: Monday, 29 July 2019 1:51 PM

To: Stephan Jacobs <StephanJ@sivest.co.za>

Subject: RE: 15324 Three (3) Solar PV Energy Facilities near Noupoort and Middelburg: DSR Comment Period Starting

I can just mention we have had interaction with the EDF team regarding this applications and I do have a good idea of what is coming in future. I just need to have the actual plans when you are at the point where routes and layouts are determined, so that we can interact if necessary. EDF is aware of the setbacks issue and we have discussed it with them previously.

Regards
John

From: Stephan Jacobs [<mailto:StephanJ@sivest.co.za>]

Sent: 29 July 2019 01:04 PM

To: John Geeringh

Cc: Andrea Gibb; sivest_PPP; Hlengiwe Ntuli

Subject: RE: 15324 Three (3) Solar PV Energy Facilities near Noupoort and Middelburg: DSR Comment Period Starting

Importance: High

Good Afternoon Mr Geeringh,

Thank you for your email and the attachments. We will ensure that these are forwarded to the applicant for consideration.

As requested, please find attached KML/KMZ files of the affected properties for the respective proposed solar Photovoltaic (PV) energy facilities.

Please be advised that the proposed grid connections will be assessed as part of separate Basic Assessment (BA) processes which will only commence at a later stage, and thus the layouts we have at this stage are only preliminary. We will therefore forward you KML/KMZ files for the grid connections when we commence the BA processes for the grid connections. We will also send you another notification when these BA processes commence. I trust this is in order.

Please do not hesitate to contact me should there be any issues or should you have any queries in this regard.

Kind Regards,

Stephan Jacobs (B.Sc. (Hons) Environmental Management and Analysis)
Environmental Consultant / Visual Specialist
SiVEST Environmental Division



SiVEST is a Level 3 BBBEE Contributor

D +27 11 798 0677 | **T** +27 011 798 0600 | **M** +27 72 737 2114 **E** stephanj@sivest.co.za | **W** www.sivest.co.za

Engineering Consulting | Project Management | Environmental Consulting | Town & Regional Planning | Management Systems Consulting

Durban | Johannesburg | Pretoria | Pietermaritzburg | Richards Bay | Port Louis (Mauritius)

From: John Geeringh [<mailto:GeerinJH@eskom.co.za>]

Sent: Monday, 29 July 2019 9:25 AM

To: sivest_PPP <sivest_ppp@sivest.co.za>

Cc: Andrea Gibb <AndreaG@sivest.co.za>; Stephan Jacobs <StephanJ@sivest.co.za>

Subject: RE: 15324 Three (3) Solar PV Energy Facilities near Noupoort and Middelburg: DSR Comment Period Starting

Please find attached Eskom requirements for works at or near Eskom infrastructure. Please also find attached the Eskom setbacks document that regulates the setback distance for RE plant from Eskom infrastructure.

Please send me a KMZ file of the affected properties and proposed Grid connections.

Kind regards

John Geeringh (Pr Sci Nat)
Senior Consultant Environmental Management
Group Capital Division: Land Development and Management
Megawatt Park, D1Y42, Maxwell Drive, Sunninghill, Sandton.
P O Box 1091, Johannesburg, 2000.
Tel: 011 516 7233
Cell: 083 632 7663
Fax: 086 661 4064
E-mail: john.geeringh@eskom.co.za



From: sivest_PPP [mailto:sivest_ppp@sivest.co.za]

Sent: 26 July 2019 03:35 PM

Cc: Andrea Gibb; Stephan Jacobs

Subject: 15324 Three (3) Solar PV Energy Facilities near Noupoort and Middelburg: DSR Comment Period Starting

Dear Interested and/or Affected Party

ENVIRONMENTAL IMPACT ASSESSMENT PROCESS (EIA) AND BASIC ASSESSMENTS (BAS) FOR THE PROPOSED DEVELOPMENT OF THREE (3) SOLAR PHOTOVOLTAIC (PV) ENERGY FACILITIES AND ASSOCIATED GRID INFRASTRUCTURE NEAR NOUPOORT AND MIDDELBURG IN THE NORTHERN AND EASTERN CAPE PROVINCES

- **MOOI PLAATS SOLAR PV – (DEA Ref No.: To be Announced)**
- **WONDERHEUVEL SOLAR PV – (DEA Ref No.: To be Announced)**
- **PAARDE VALLEY SOLAR PV – (DEA Ref No.: To be Announced)**
- **MOOI PLAATS GRID – (DEA Ref No.: To be Announced)**
- **WONDERHEUVEL GRID – (DEA Ref No.: To be Announced)**
- **PAARDE VALLEY GRID – (DEA Ref No.: To be Announced)**

Please note that SiVEST SA (Pty) Ltd has been appointed as the Environmental Assessment Practitioner (EAP) for the abovementioned projects.

We would like to take this opportunity to inform you that, in accordance with the National Environmental Management Act, 1998 (Act No. 107 of 1998) (NEMA) (as amended), the Draft Scoping Reports (DSRs) for the above mentioned projects will be available for public comment and review as from **Friday 26 July 2019 to Monday 26 August 2019** (end of business day). Should you wish to receive an electronic copy of the DSRs (on CD) please forward your request in writing to us. Hard copies of the DSRs can be reviewed at the following public places:

| VENUE | REPORT/S | STREET ADDRESS | HOURS | CONTACT NO |
|--------------------|-------------------------------------------|----------------------------------------|--------------------------------------------------------|-------------------|
| Noupoort Library | Mooi Plaats PV DSR Wonderheuvel PV DSR | Shaw St, Noupoort, 5950 | Mondays - Fridays 10:00 - 13:00 13:45 - 16:30 | 049 843 1056 |
| Middelburg Library | Paarde Valley PV DSR | 47 Van Reenen Street, Middelburg, 5900 | Mondays - Fridays 09:00 - 16:30 | 049 802 1300 |

The reports as well as the accompanying appendices are also available on SiVEST's website: <http://www.sivest.co.za/>, click on Downloads, then browse to the folder '15324 Umsobomvu PV and Grid'.

Attached is an English and Afrikaans letter notifying you of the review period as well as the background information document (BID).

Kind Regards,

Stephan Jacobs (B.Sc. (Hons) Environmental Management and Analysis)
Environmental Consultant / Visual Specialist
SiVEST Environmental Division

The information contained in this communication from the sender is confidential. It is intended solely for use by the recipient and others authorized to receive it. If you are not the recipient, you are hereby notified that any disclosure, copying, distribution or taking action in relation of the contents of this information is strictly prohibited and may be unlawful.

This email has been scanned for viruses and malware, and automatically archived by **Mimecast SA (Pty) Ltd**, an innovator in Software as a Service (SaaS) for business. **Mimecast Unified Email Management ??? (UEM)** offers email continuity, security, archiving and compliance with all current legislation. To find out more, [contact Mimecast](#).

NB: This Email and its contents are subject to the Eskom Holdings SOC Ltd EMAIL LEGAL NOTICE which can be viewed at http://www.eskom.co.za/Pages/Email_Legal_Spam_Disclaimer.aspx

Stephan Jacobs

From: Stephan Jacobs
Sent: Tuesday, 11 February 2020 8:11 AM
To: 'Natasha Higgitt'; sivest_PPP
Cc: Liandra Scott-Shaw; 'Sheldon.vandrey@edf-re.co.za'
Subject: RE: 15324 Three (3) Solar PV Energy Facilities and Grid Infrastructures near Noupoot and Middelburg: DBAR Comment Period Starting

Good Morning Natasha,

The email below refers.

Thank you for your email. Please be advised that SiVEST are in the process of creating the relevant case applications via the South African Heritage Resources Information System (SAHRIS) and will ensure that all documents pertaining to the Environmental Authorisation (EA) Application Process are uploaded. Once all documents have been uploaded to the relevant case applications we will make sure that the status of the cases are changed from DRAFT to SUBMITTED. SiVEST will inform you once the relevant case applications have been created, the documents have been uploaded and the cases and the status of the cases have been changed to SUBMITTED.

Please take note that Heritage and Palaeontological Impact Assessments have formed part of the BA processes and the assessment have complied with section 38(3) of the NHRA. These studies will be uploaded to the relevant SAHRIS case applications.

Thank you for your input.

Kind Regards,

Stephan Jacobs (B.Sc. (Hons) Environmental Management and Analysis)
Environmental Consultant / Visual Specialist
SiVEST Environmental Division



SiVEST is a Level 3 BBBEE Contributor

D +27 11 798 0677 | **T** +27 011 798 0600 | **M** +27 72 737 2114 **E** stephanj@sivest.co.za | **W** www.sivest.co.za

Engineering Consulting | Project Management | Environmental Consulting | Town & Regional Planning | Management Systems Consulting

Durban | Johannesburg | Pretoria | Pietermaritzburg | Richards Bay | Port Louis (Mauritius)

From: Natasha Higgitt [mailto:nhiggitt@sahra.org.za]
Sent: Tuesday, 11 February 2020 8:03 AM
To: sivest_PPP <sivest_ppp@sivest.co.za>
Cc: Stephan Jacobs <StephanJ@sivest.co.za>; Liandra Scott-Shaw <LiandraS@sivest.co.za>; 'Sheldon.vandrey@edf-re.co.za' <Sheldon.vandrey@edf-re.co.za>
Subject: RE: 15324 Three (3) Solar PV Energy Facilities and Grid Infrastructures near Noupoot and Middelburg: DBAR Comment Period Starting

Good morning,

Please note that all development applications are processed via our online portal, the South African Heritage Resources Information System (SAHRIS) found at the following link: <http://sahra.org.za/sahris/>. We do not accept emailed, posted, hardcopy, faxed, website links or DropBox links as official submissions.

Please create an application on SAHRIS and upload all documents pertaining to the Environmental Authorisation Application Process. As per section 38(8) of the National Heritage Resources Act, Act 25 of 1999 (NHRA), an assessment of heritage resources must form part of the process and the assessment must comply with section 38(3) of the NHRA.

Once all documents including all appendices are uploaded to the case application, please ensure that the status of the case is changed from DRAFT to SUBMITTED. Please ensure that all documents produced as part of the EA process are submitted as part of the application, and are submitted to SAHRA at the beginning of the Public Review periods. Once all these documents have been uploaded, I will be able to issue an informed comment as per section 38(4) and 38(8) of the NHRA.

From: sivest_PPP <sivest_ppp@sivest.co.za>
Sent: Monday, 10 February 2020 17:04
Cc: Stephan Jacobs <StephanJ@sivest.co.za>; Liandra Scott-Shaw <LiandraS@sivest.co.za>; 'Sheldon.vandrey@edf-re.co.za' <Sheldon.vandrey@edf-re.co.za>
Subject: 15324 Three (3) Solar PV Energy Facilities and Grid Infrastructures near Noupoort and Middelburg: DBAR Comment Period Starting

Dear Interested and/or Affected Party (I&AP),

BASIC ASSESSMENTS (BAs) FOR THE PROPOSED DEVELOPMENT OF THE THREE (3) GRID CONNECTION INFRASTRUCTURE DEVELOPMENTS (SUBSTATIONS AND POWER LINES) NEAR NOUPOORT AND MIDDELBURG IN THE NORTHERN AND EASTERN CAPE PROVINCES

- **Mooi Plaats Grid – (DEA Ref No: To be announced)**
- **Wonderheuvel Grid – (DEA Ref No: To be announced)**
- **Paarde Valley Grid – (DEA Ref No: To be announced)**

Please note that SiVEST SA (Pty) Ltd has been appointed as the independent Environmental Assessment Practitioner (EAP) to undertake the Basic Assessment (BA) processes for the above-mentioned proposed projects.

We would like to take this opportunity to inform you that, in accordance with the National Environmental Management Act, 1998 (Act No. 107 of 1998) (NEMA) (as amended), the Draft Basic Assessment Reports (DBARs) for the above-mentioned proposed projects will be available for public comment and review as from **Monday the 10th of February 2020 to Wednesday the 11th of March 2020** (end of business day). Should you wish to receive an electronic copy of the DBARs (on CD), please forward your request in writing to us. Comments can be submitted to:

Hlengiwe Ntuli
PO Box 2921, RIVONIA, 2128
Phone: (011) 798 0600
E-mail: sivest_ppp@sivest.co.za / hlengiwen@sivest.co.za / stephanj@sivest.co.za
Fax: (011) 803 7272

Hard copies of the DBARs can be reviewed at the following public places:

| VENUE | REPORT(S) | STREET ADDRESS | HOURS | CONTACT NO |
|-------------------------|-----------------------|-------------------------|----------------------------------------------------------------|--------------|
| Noupoort Public Library | Mooi Plaats Grid DBAR | Shaw St, Noupoort, 5950 | Mondays - Fridays 10:00 - 13:00 13:45 - 16:30 | 049 843 1056 |

| | | | | |
|---------------------------|----------------------------|-------------------------------------------|---------------------------------|-----------------|
| Middelburg Public Library | Wonderheuvel Grid DBAR | 47 Van Reenen Street, Middelburg, 5900 | Mondays - | 049 802 1300 |
| | Paarde Valley Grid DBAR | | Fridays 09:00 - 16:30 | |

The reports as well as the accompanying appendices are also available on SiVEST's website: <http://www.sivest.co.za/>, click on 'Downloads', then browse to the folder '15324 Umsobomvu PV and Grid'. Please reference 'Mooi Plaats / Wonderheuvel / Paarde Valley Grid' in your correspondence, should your comments be project specific.

We would like to thank you in anticipation of your active and meaningful contribution to the BA and public participation processes.

Geagte Belangstellende en/of Geaffekteerde Party,

BASIESE EVALUERINGS (BEs) VIR DIE BEOOGDE ONTWIKKELING VAN DIE DRIE (3) NETWERKVERBINDINGSINFRASTRUKTUURONTWIKKELINGS (SUBSTASIES EN KRAGLYNE) NABY NOUPOORT EN MIDDELBURG IN DIE NOORD- EN OOS-KAAPPROVINSIES

- **MOOI PLAATS SUBSTASIES EN KRAGLYN – (DO-verw. No.: Moet nog aangekondig word)**
- **WONDERHEUVEL SUBSTASIES EN KRAGLYN – (DO-verw. No.: Moet nog aangekondig word)**
- **PAARDE VALLEY SUBSTASIES EN KRAGLYN – (DO-verw. No.: Moet nog aangekondig word)**

Ons stel u graag in kennis dat SiVEST SA (Edms) Bpk aangestel is as die onafhanklike Omgewingsevalueringspraktisyn (OEP) om die Basiese Evaluerings- (BE) prosesse vir die bogenoemde voorgestelde projekte te onderneem.

Ons wil graag van hierdie geleentheid gebruik maak om u in te lig dat ingevolge die Nasionale Wet op Omgewingsbestuur (NEMA) (Wet No. 107 van 1998) (soos gewysig), sal die Konsep Basiese Evalueeringsverslae (KBEVs) vir die bogenoemde voorgestelde projekte vanaf **Maandag 10 Februarie 2020** tot **Woensdag 11 Maart 2020** (teen sluitingstyd) beskikbaar wees vir openbare kommentaar en insae. As u elektroniese kopie van die KBEVs (op CD) wil ontvang, moet u dit asseblief skriftelik by ons versoek. Kommentaar kan soos volg ingedien word:

Hlengiwe Ntuli

Posbus 2921, RIVONIA, 2128

Foon: (011) 798 0600

E-pos: sivest_ppp@sivest.co.za / hlengiw@zivest.co.za / stephanj@sivest.co.za

Faks: (011) 803 7272

Gedrukte kopie van die KBEVs kan by die volgende openbare plekke nagegaan word:

| PLEK | VERSLAG / VERSLAE | STRAATADRES | TYE | KONTAKNOMMERS |
|--------------------------------------|-----------------------------------------------|------------------------------------------|--------------------------------------|---------------|
| Noupoort Publieke Biblioteek | Mooi Plaats Substasie en Kraglyn KBEV | Shawstraat, Noupoort, 5950 | Maandae - Vrydae | 049 843 1056 |
| | | | 10:00 - 13:00 13:45 - 16:30 | |
| Middelburg Publieke Biblioteek | Wonderheuvel Substasie en Kraglyn KBEV | Van Reenenstraat 47, Middelburg, 5900 | Maandae - Vrydae | 049 802 1300 |
| | | | 09:00 - 16:30 | |
| | Paarde Valley Substasie en Kraglyn KBEV | | | |

Die verslae, sowel as die meegaande aanhangsels, is ook beskikbaar op SiVEST se webwerf: <http://www.sivest.co.za/>, klik op 'Downloads' en soek dan vir die legger '15324 Umsobomvu PV and Grid'. Verwys asseblief 'Mooi Plaats / Wonderheuvel / Paarde Valley Grid' in u korrespondensie, indien u kommentaar spesifiek op die projek is.

Ons dank u byvoorbaat vir u aktiewe en betekenisvolle bydrae tot die BE en Openbare Deelnameprosesse.

Kind Regards,

Stephan Jacobs (B.Sc. (Hons) Environmental Management and Analysis)

Environmental Consultant / Visual Specialist

SiVEST Environmental Division

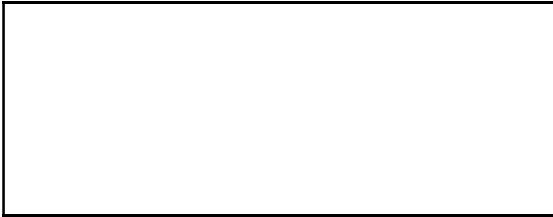

SiVEST is a Level 3 BBBEE Contributor

D +27 11 798 0677 | **T** +27 011 798 0600 **E** stephanj@sivest.co.za | **W** www.sivest.co.za

Engineering Consulting | Project Management | Environmental Consulting | Town & Regional Planning | Management Systems Consulting

Durban | Johannesburg | Pretoria | Pietermaritzburg | Richards Bay | Port Louis (Mauritius)

Disclaimer

The information contained in this communication from the sender is confidential. It is intended solely for use by the recipient and others authorized to receive it. If you are not the recipient, you are hereby notified that any disclosure, copying, distribution or taking action in relation of the contents of this information is strictly prohibited and may be unlawful.

This email has been scanned for viruses and malware, and automatically archived by **Mimecast SA (Pty) Ltd**, an innovator in Software as a Service (SaaS) for business. **Mimecast Unified Email Management ??? (UEM)** offers email continuity, security, archiving and compliance with all current legislation. To find out more, [contact Mimecast](#).

Natasha Higgitt

Heritage Officer: Archaeology, Palaeontology and Meteorites Unit

South African Heritage Resources Agency

- A nation united through heritage -

T: +27 21 462 4502/ 8660 | **C:** +27 82 507 0378 | **F:** +27 21 462 4509

E: nhiggitt@sahra.org.za | 111 Harrington Street | Cape Town |

www.sahra.org.za



an agency of the
Department of Arts and Culture

*OUR VALUES: Accountability, Teamwork & co-operation, Respect, Transparency,
Service Excellency, Integrity & Ethics, Professionalism, Accessibility, Communication & Trust.*

BREAK THE CORRUPTION CHAIN
REPORT FRAUD & CORRUPTION: 0800 701 701



an agency of the
Department of Arts and Culture

UNMASK THE CORRUPT



sivest_PPP

From: sivest_PPP
Sent: 17 February 2020 11:52 AM
To: 'Natasha Higgitt'
Cc: Stephan Jacobs; Liandra Scott-Shaw; 'Sheldon.vandrey@edf-re.co.za'
Subject: RE: 15324 Three (3) Solar PV Energy Facilities and Grid Infrastructures near Noupoort and Middelburg: DBAR Comment Period Starting

Importance: High

Good Day Natasha,

We have been trying to create cases on your website with no success from last week and even this morning.

Please see error below:

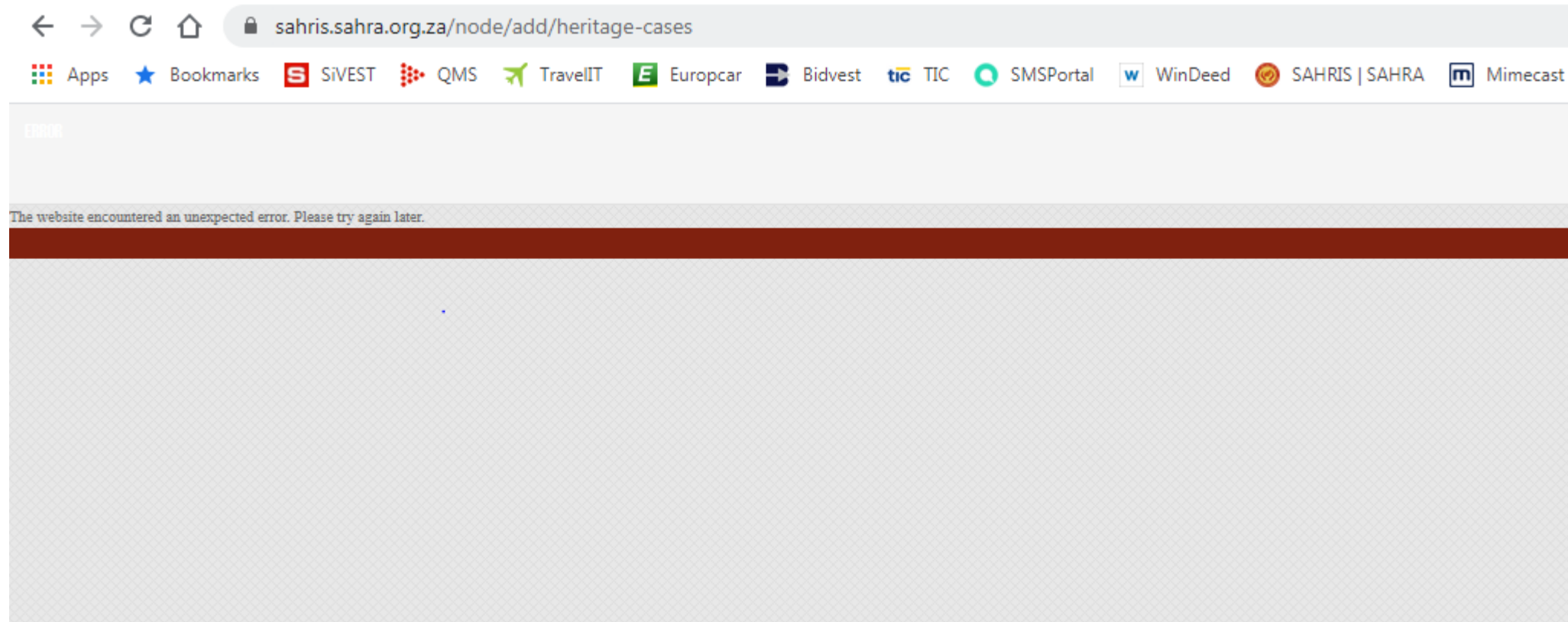

From: Natasha Higgitt [mailto:nhiggitt@sahra.org.za]
Sent: 11 February 2020 08:03 AM
To: sivest_PPP <sivest_ppp@sivest.co.za>
Cc: Stephan Jacobs <StephanJ@sivest.co.za>; Liandra Scott-Shaw <LiandraS@sivest.co.za>; 'Sheldon.vandrey@edf-re.co.za' <Sheldon.vandrey@edf-re.co.za>
Subject: RE: 15324 Three (3) Solar PV Energy Facilities and Grid Infrastructures near Noupoort and Middelburg: DBAR Comment Period Starting

Good morning,

Please note that all development applications are processed via our online portal, the South African Heritage Resources Information System (SAHRIS) found at the following link: <http://sahra.org.za/sahrissahra/>. We do not accept emailed, posted, hardcopy, faxed, website links or DropBox links as official submissions.

Please create an application on SAHRIS and upload all documents pertaining to the Environmental Authorisation Application Process. As per section 38(8) of the National Heritage Resources Act, Act 25 of 1999 (NHRA), an assessment of heritage resources must form part of the process and the assessment must comply with section 38(3) of the NHRA.

Once all documents including all appendices are uploaded to the case application, please ensure that the status of the case is changed from DRAFT to SUBMITTED. Please ensure that all documents produced as part of the EA process are submitted as part of the application, and are submitted to SAHRA at the beginning of the Public Review periods. Once all these documents have been uploaded, I will be able to issue an informed comment as per section 38(4) and 38(8) of the NHRA.

From: sivest_PPP <sivest_ppp@sivest.co.za>
Sent: Monday, 10 February 2020 17:04
Cc: Stephan Jacobs <StephanJ@sivest.co.za>; Liandra Scott-Shaw <LiandraS@sivest.co.za>; 'Sheldon.vandrey@edf-re.co.za' <Sheldon.vandrey@edf-re.co.za>
Subject: 15324 Three (3) Solar PV Energy Facilities and Grid Infrastructures near Noupoort and Middelburg: DBAR Comment Period Starting

Dear Interested and/or Affected Party (I&AP),

BASIC ASSESSMENTS (BAs) FOR THE PROPOSED DEVELOPMENT OF THE THREE (3) GRID CONNECTION INFRASTRUCTURE DEVELOPMENTS (SUBSTATIONS AND POWER LINES) NEAR NOUPOORT AND MIDDELBURG IN THE NORTHERN AND EASTERN CAPE PROVINCES

- **Mooi Plaats Grid – (DEA Ref No: To be announced)**
- **Wonderheuvel Grid – (DEA Ref No: To be announced)**
- **Paarde Valley Grid – (DEA Ref No: To be announced)**

Please note that SiVEST SA (Pty) Ltd has been appointed as the independent Environmental Assessment Practitioner (EAP) to undertake the Basic Assessment (BA) processes for the above-mentioned proposed projects.

We would like to take this opportunity to inform you that, in accordance with the National Environmental Management Act, 1998 (Act No. 107 of 1998) (NEMA) (as amended), the Draft Basic Assessment Reports (DBARs) for the above-mentioned proposed projects will be available for public comment and review as from **Monday the 10th of February 2020 to Wednesday the 11th of March 2020** (end of business day). Should you wish to receive an electronic copy of the DBARs (on CD), please forward your request in writing to us. Comments can be submitted to:

Hlengiwe Ntuli
 PO Box 2921, RIVONIA, 2128
 Phone: (011) 798 0600
 E-mail: sivest_ppp@sivest.co.za / hlengiwen@sivest.co.za / stephanj@sivest.co.za
 Fax: (011) 803 7272

Hard copies of the DBARs can be reviewed at the following public places:

| VENUE | REPORT(S) | STREET ADDRESS | HOURS | CONTACT NO |
|---------------------------|----------------------------------------------------|----------------------------------------|----------------------------------------------------------------|--------------|
| Noupoort Public Library | Mooi Plaats Grid DBAR | Shaw St, Noupoort, 5950 | Mondays - Fridays 10:00 - 13:00 13:45 - 16:30 | 049 843 1056 |
| Middelburg Public Library | Wonderheuveld Grid DBAR Paarde Valley Grid DBAR | 47 Van Reenen Street, Middelburg, 5900 | Mondays - Fridays 09:00 - 16:30 | 049 802 1300 |

The reports as well as the accompanying appendices are also available on SiVEST's website: <http://www.sivest.co.za/>, click on 'Downloads', then browse to the folder '15324 Umsobomvu PV and Grid'. Please reference 'Mooi Plaats / Wonderheuveld / Paarde Valley Grid' in your correspondence, should your comments be project specific.

We would like to thank you in anticipation of your active and meaningful contribution to the BA and public participation processes.

Geagte Belangstellende en/of Geaffekteerde Party,

BASIESE EVALUERINGS (BEs) VIR DIE BEOOGDE ONTWIKKELING VAN DIE DRIE (3) NETWERKVERBINDINGSINFRASTRUKTUURONTWIKKELINGS (SUBSTASIES EN KRAGLYNE) NABY NOUPOORT EN MIDDELBURG IN DIE NOORD- EN OOS-KAAPROVINSIES

- **MOOI PLAATS SUBSTASIES EN KRAGLYN – (DO-verw. No.: Moet nog aangekondig word)**
- **WONDERHEUVEL SUBSTASIES EN KRAGLYN – (DO-verw. No.: Moet nog aangekondig word)**
- **PAARDE VALLEY SUBSTASIES EN KRAGLYN – (DO-verw. No.: Moet nog aangekondig word)**

Ons stel u graag in kennis dat SiVEST SA (Edms) Bpk aangestel is as die onafhanklike Omgewingsevalueringsspraktisyn (OEP) om die Basiese Evaluering- (BE) prosesse vir die bogenoemde voorgestelde projekte te onderneem.

Ons wil graag van hierdie geleentheid gebruik maak om u in te lig dat ingevolge die Nasionale Wet op Omgewingsbestuur (NEMA) (Wet No. 107 van 1998) (soos gewysig), sal die Konsep Basiese Evalueringverslae (KBEVs) vir die bogenoemde voorgestelde projekte vanaf **Maandag 10 Februarie 2020** tot **Woensdag 11 Maart 2020** (teen sluitingstyd) beskikbaar wees vir openbare kommentaar en insae. As u elektroniese kopie van die KBEVs (op CD) wil ontvang, moet u dit asseblief skriftelik by ons versoek. Kommentaar kan soos volg ingedien word:

Hlengiwe Ntuli
 Posbus 2921, RIVONIA, 2128
 Foon: (011) 798 0600
 E-pos: sivest_ppp@sivest.co.za / hlengiwen@sivest.co.za / stephanj@sivest.co.za
 Faks: (011) 803 7272

Gedrukte kopie van die KBEVs kan by die volgende openbare plekke nagegaan word:

| PLEK | VERSLAG / VERSLAE | STRAATADRES | TYE | KONTAKNOMMERS |
|--------------------------------|------------------------------------------------------------------------------------|---------------------------------------|---------------------------------------------------------------|---------------|
| Noupoort Publieke Biblioteek | Mooi Plaats Substasie en Kraglyn KBEV | Shawstraat, Noupoort, 5950 | Maandae - Vrydae 10:00 - 13:00 13:45 - 16:30 | 049 843 1056 |
| Middelburg Publieke Biblioteek | Wonderheuveld Substasie en Kraglyn KBEV Paarde Valley Substasie en Kraglyn KBEV | Van Reenenstraat 47, Middelburg, 5900 | Maandae - Vrydae 09:00 - 16:30 | 049 802 1300 |

Die verslae, sowel as die meegaande aanhangsels, is ook beskikbaar op SiVEST se webwerf: <http://www.sivest.co.za/>, klik op 'Downloads' en soek dan vir die legger '15324 Umsobomvu PV and Grid'. Verwys asseblief 'Mooi Plaats / Wonderheuveld / Paarde Valley Grid' in u korrespondensie, indien u kommentaar spesifiek op die projek is.

Ons dank u byvoorbeeld vir u aktiewe en betekenisvolle bydrae tot die BE en Openbare Deelnameprosesse.

Kind Regards,
Stephan Jacobs (B.Sc. (Hons) Environmental Management and Analysis)
 Environmental Consultant / Visual Specialist
SiVEST Environmental Division





SiVEST is a Level 3 BBBEE Contributor

D +27 11 798 0677 | T +27 011 798 0600 E stephanj@sivest.co.za | W www.sivest.co.za
Engineering Consulting | Project Management | Environmental Consulting | Town & Regional Planning | Management Systems Consulting
Durban | Johannesburg | Pretoria | Pietermaritzburg | Richards Bay | Port Louis (Mauritius)

Disclaimer

The information contained in this communication from the sender is confidential. It is intended solely for use by the recipient and others authorized to receive it. If you are not the recipient, you are hereby notified that any disclosure, copying, distribution or taking action in relation of the contents of this information is strictly prohibited and may be unlawful.

This email has been scanned for viruses and malware, and automatically archived by Mimecast SA (Pty) Ltd, an innovator in Software as a Service (SaaS) for business. Mimecast Unified Email Management (UEM) offers email continuity, security, archiving and compliance with all current legislation. To find out more, [contact Mimecast](#).

Natasha Higgitt

Heritage Officer: Archaeology, Palaeontology and Meteorites Unit

South African Heritage Resources Agency
- A nation united through heritage -

T: +27 21 462 4502/ 8660 | C:+27 82 507 0378 | F:+27 21 462 4509
E: nhiggitt@sahra.org.za | 111 Harrington Street | Cape Town |

www.sahra.org.za



an agency of the
Department of Arts and Culture

OUR VALUES: Accountability, Teamwork & co-operation, Respect, Transparency, Service Excellency, Integrity & Ethics, Professionalism, Accessibility, Communication & Trust.

BREAK THE CORRUPTION CHAIN
REPORT FRAUD & CORRUPTION: 0800 701 701



an agency of the
Department of Arts and Culture



sivest_PPP

From: sivest_PPP
Sent: 17 February 2020 01:29 PM
To: 'Nonyameko Mlungwana'; Natasha Higgitt
Cc: Stephan Jacobs; Liandra Scott-Shaw; 'Sheldon.vandrey@edf-re.co.za'; Leomile Mofutsanyana
Subject: RE: 15324 Three (3) Solar PV Energy Facilities and Grid Infrastructures near Noupoot and Middelburg: DBAR Comment Period Starting

Importance: High

Thank you so much.

Please note that the Cases have now been loaded.

Mooi Plaats Grid BA – case 14884
Wonderheuvel Grid BA – case 14885

From: Nonyameko Mlungwana [mailto:nmlungwana@sahra.org.za]
Sent: 17 February 2020 12:33 PM
To: Natasha Higgitt <nhiggitt@sahra.org.za>; sivest_PPP <sivest_ppp@sivest.co.za>
Cc: Stephan Jacobs <StephanJ@sivest.co.za>; Liandra Scott-Shaw <LiandraS@sivest.co.za>; 'Sheldon.vandrey@edf-re.co.za' <Sheldon.vandrey@edf-re.co.za>; Leomile Mofutsanyana <lmofutsanyana@sahra.org.za>
Subject: RE: 15324 Three (3) Solar PV Energy Facilities and Grid Infrastructures near Noupoot and Middelburg: DBAR Comment Period Starting

Good day,

Please create a draft case and save it without uploading the documents, then edit the draft case to upload the pdf documents. In most cases it crashes when you create the case and upload the documents at the same time. If it still crashes let us know.

Kind regards

From: Natasha Higgitt <nhiggitt@sahra.org.za>
Sent: 17 February 2020 12:06 PM
To: sivest_PPP <sivest_ppp@sivest.co.za>
Cc: Stephan Jacobs <StephanJ@sivest.co.za>; Liandra Scott-Shaw <LiandraS@sivest.co.za>; 'Sheldon.vandrey@edf-re.co.za' <Sheldon.vandrey@edf-re.co.za>; Nonyameko Mlungwana <nmlungwana@sahra.org.za>; Leomile Mofutsanyana <lmofutsanyana@sahra.org.za>
Subject: RE: 15324 Three (3) Solar PV Energy Facilities and Grid Infrastructures near Noupoot and Middelburg: DBAR Comment Period Starting

Good afternoon,

Thank you for the notification.

Nonyameko/Leomile, please can you assist Sivest with their applications as per the email below?

Thank you.

From: sivest_PPP <sivest_ppp@sivest.co.za>
Sent: Monday, 17 February 2020 11:52
To: Natasha Higgitt <nhiggitt@sahra.org.za>
Cc: Stephan Jacobs <StephanJ@sivest.co.za>; Liandra Scott-Shaw <LiandraS@sivest.co.za>; 'Sheldon.vandrey@edf-re.co.za' <Sheldon.vandrey@edf-re.co.za>
Subject: RE: 15324 Three (3) Solar PV Energy Facilities and Grid Infrastructures near Noupoot and Middelburg: DBAR Comment Period Starting
Importance: High

Good Day Natasha,

We have been trying to create cases on your website with no success from last week and even this morning.

Please see error below:

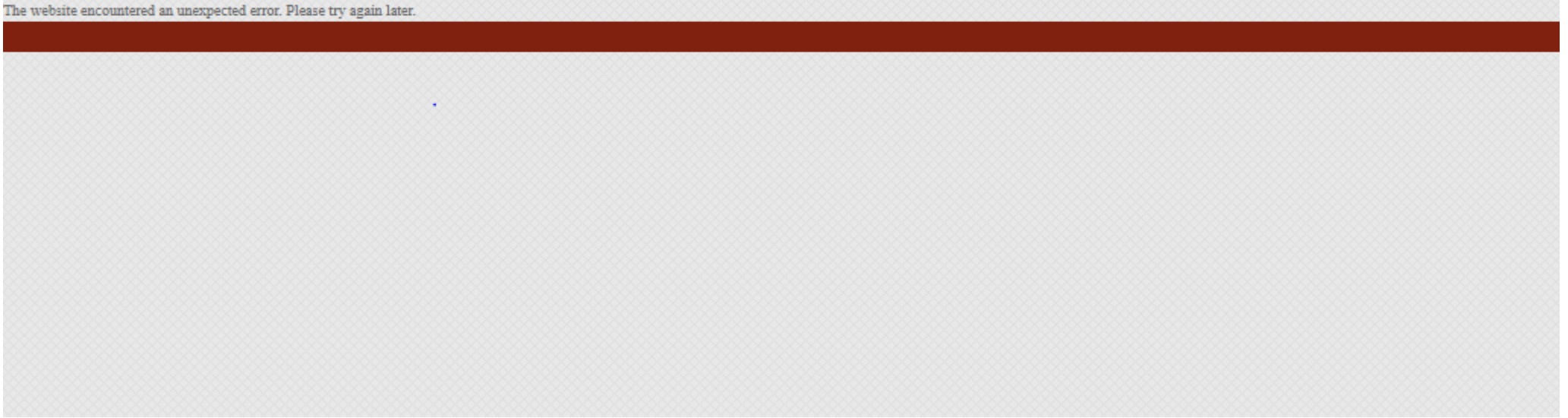
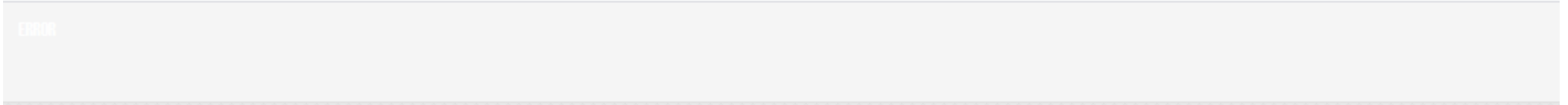

From: Natasha Higgitt [<mailto:nhiggitt@sahra.org.za>]
Sent: 11 February 2020 08:03 AM
To: sivist_PPP <sivist_ppp@sivest.co.za>
Cc: Stephan Jacobs <StephanJ@sivest.co.za>; Liandra Scott-Shaw <LiandraS@sivest.co.za>; 'Sheldon.vandrey@edf-re.co.za' <Sheldon.vandrey@edf-re.co.za>
Subject: RE: 15324 Three (3) Solar PV Energy Facilities and Grid Infrastructures near Noupoot and Middelburg: DBAR Comment Period Starting

Good morning,

Please note that all development applications are processed via our online portal, the South African Heritage Resources Information System (SAHRIS) found at the following link: <http://sahra.org.za/sahris/>. We do not accept emailed, posted, hardcopy, faxed, website links or DropBox links as official submissions.

Please create an application on SAHRIS and upload all documents pertaining to the Environmental Authorisation Application Process. As per section 38(8) of the National Heritage Resources Act, Act 25 of 1999 (NHRA), an assessment of heritage resources must form part of the process and the assessment must comply with section 38(3) of the NHRA.

Once all documents including all appendices are uploaded to the case application, please ensure that the status of the case is changed from DRAFT to SUBMITTED. Please ensure that all documents produced as part of the EA process are submitted as part of the application, and are submitted to SAHRA at the beginning of the Public Review periods. Once all these documents have been uploaded, I will be able to issue an informed comment as per section 38(4) and 38(8) of the NHRA.

From: sivist_PPP <sivist_ppp@sivest.co.za>
Sent: Monday, 10 February 2020 17:04
Cc: Stephan Jacobs <StephanJ@sivest.co.za>; Liandra Scott-Shaw <LiandraS@sivest.co.za>; 'Sheldon.vandrey@edf-re.co.za' <Sheldon.vandrey@edf-re.co.za>
Subject: 15324 Three (3) Solar PV Energy Facilities and Grid Infrastructures near Noupoot and Middelburg: DBAR Comment Period Starting

Dear Interested and/or Affected Party (I&AP),

BASIC ASSESSMENTS (BAs) FOR THE PROPOSED DEVELOPMENT OF THE THREE (3) GRID CONNECTION INFRASTRUCTURE DEVELOPMENTS (SUBSTATIONS AND POWER LINES) NEAR NOUPOORT AND MIDDELBURG IN THE NORTHERN AND EASTERN CAPE PROVINCES

- **Mooi Plaats Grid – (DEA Ref No: To be announced)**
- **Wonderheuvel Grid – (DEA Ref No: To be announced)**
- **Paarde Valley Grid – (DEA Ref No: To be announced)**

Please note that SiVEST SA (Pty) Ltd has been appointed as the independent Environmental Assessment Practitioner (EAP) to undertake the Basic Assessment (BA) processes for the above-mentioned proposed projects.

We would like to take this opportunity to inform you that, in accordance with the National Environmental Management Act, 1998 (Act No. 107 of 1998) (NEMA) (as amended), the Draft Basic Assessment Reports (DBARs) for the above-mentioned proposed projects will be available for public comment and review as from **Monday the 10th of February 2020 to Wednesday the 11th of March 2020** (end of business day). Should you wish to receive an electronic copy of the DBARs (on CD), please forward your request in writing to us. Comments can be submitted to:

Hlengiwe Ntuli
PO Box 2921, RIVONIA, 2128
Phone: (011) 798 0600
E-mail: sivist_ppp@sivest.co.za / hlengiwen@sivest.co.za / stephanj@sivest.co.za
Fax: (011) 803 7272

Hard copies of the DBARs can be reviewed at the following public places:

| VENUE | REPORT(S) | STREET ADDRESS | HOURS | CONTACT NO |
|---------------------------|------------------------|----------------------------------------|------------------------------------------------------------|--------------|
| Noupoot Public Library | Mooi Plaats Grid DBAR | Shaw St, Noupoot, 5950 | Mondays - Fridays 10:00 - 13:00 13:45 - 16:30 | 049 843 1056 |
| Middelburg Public Library | Wonderheuvel Grid DBAR | 47 Van Reenen Street, Middelburg, 5900 | Mondays - Fridays 09:00 - 16:30 | 049 802 1300 |

The reports as well as the accompanying appendices are also available on SiVEST's website: <http://www.sivest.co.za/>, click on 'Downloads', then browse to the folder '15324 Umsobomvu PV and Grid'. Please reference 'Mooi Plaats / Wonderheuvel / Paarde Valley Grid' in your correspondence, should your comments be project specific.

We would like to thank you in anticipation of your active and meaningful contribution to the BA and public participation processes.

Geagte Belangstellende en/of Geaffekteerde Party,

BASIESE EVALUERINGS (BEs) VIR DIE BEOOGDE ONTWIKKELING VAN DIE DRIE (3) NETWERKVERBINDINGSINFRASTRUKTUURONTWIKKELINGS (SUBSTASIES EN KRAGLYNE) NABY NOUPOORT EN MIDDELBURG IN DIE NOORD- EN OOS-KAAPROVINSIES

- MOOI PLAATS SUBSTASIES EN KRAGLYN – (DO-verw. No.: Moet nog aangekondig word)
- WONDERHEUVEL SUBSTASIES EN KRAGLYN – (DO-verw. No.: Moet nog aangekondig word)
- PAARDE VALLEY SUBSTASIES EN KRAGLYN – (DO-verw. No.: Moet nog aangekondig word)

Ons stel u graag in kennis dat SiVEST SA (Edms) Bpk aangestel is as die onafhanklike Omgewingsevalueringspraktisyn (OEP) om die Basiese Evalueerings- (BE) prosesse vir die bogenoemde voorgestelde projekte te onderneem.

Ons wil graag van hierdie geleentheid gebruik maak om u in te lig dat ingevolge die Nasionale Wet op Omgewingsbestuur (NEMA) (Wet No. 107 van 1998) (soos gewysig), sal die Konsep Basiese Evalueeringsverslae (KBEVs) vir die bogenoemde voorgestelde projekte vanaf **Maandag 10 Februarie 2020** tot **Woensdag 11 Maart 2020** (teen sluitingstyd) beskikbaar wees vir openbare kommentaar en insae. As u elektroniese kopie van die KBEVs (op CD) wil ontvang, moet u dit asseblief skriftelik by ons versoek. Kommentaar kan soos volg ingedien word:

Hlengiwe Ntuli

Posbus 2921, RIVONIA, 2128

Foon: (011) 798 0600

E-pos: sivest_ppp@sivest.co.za / hlengiwen@sivest.co.za / stephanj@sivest.co.za

Faks: (011) 803 7272

Gedrukte kopie van die KBEVs kan by die volgende openbare plekke nagegaan word:

| PLEK | VERSLAG / VERSLAE | STRAATADRES | TYE | KONTAKNOMMERS |
|--------------------------------------|-----------------------------------------------|------------------------------------------|--------------------------------------|---------------|
| Noupoort Publieke Biblioteek | Mooi Plaats Substasie en Kraglyn KBEV | Shawstraat, Noupoort, 5950 | Maandae - Vrydae | 049 843 1056 |
| | | | 10:00 - 13:00 13:45 - 16:30 | |
| Middelburg Publieke Biblioteek | Wonderheuvel Substasie en Kraglyn KBEV | Van Reenenstraat 47, Middelburg, 5900 | Maandae - Vrydae | 049 802 1300 |
| | Paarde Valley Substasie en Kraglyn KBEV | | 09:00 - 16:30 | |

Die verslae, sowel as die meegaande aanhangsels, is ook beskikbaar op SiVEST se webwerf: <http://www.sivest.co.za/>, klik op 'Downloads' en soek dan vir die legger '15324 Umsobomvu PV and Grid'. Verwys asseblief 'Mooi Plaats / Wonderheuvel / Paarde Valley Grid' in u korrespondensie, indien u kommentaar spesifiek op die projek is.

Ons dank u byvoorbaat vir u aktiewe en betekenisvolle bydrae tot die BE en Openbare Deelnameprosesse.

Kind Regards,

Stephan Jacobs (B.Sc. (Hons) Environmental Management and Analysis)

Environmental Consultant / Visual Specialist

SiVEST Environmental Division

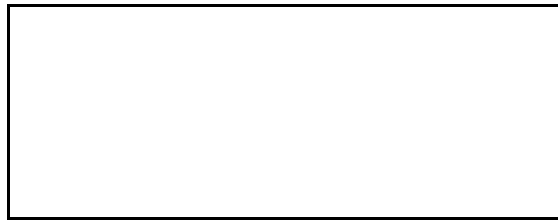

SiVEST is a Level 3 BBBEE Contributor

D +27 11 798 0677 | T +27 011 798 0600 E stephanj@sivest.co.za | W www.sivest.co.za

Engineering Consulting | Project Management | Environmental Consulting | Town & Regional Planning | Management Systems Consulting
Durban | Johannesburg | Pretoria | Pietermaritzburg | Richards Bay | Port Louis (Mauritius)

The information contained in this communication from the sender is confidential. It is intended solely for use by the recipient and others authorized to receive it. If you are not the recipient, you are hereby notified that any disclosure, copying, distribution or taking action in relation of the contents of this information is strictly prohibited and may be unlawful.

This email has been scanned for viruses and malware, and automatically archived by **Mimecast SA (Pty) Ltd**, an innovator in Software as a Service (SaaS) for business. **Mimecast Unified Email Management ??? (UEM)** offers email continuity, security, archiving and compliance with all current legislation. To find out more, [contact Mimecast](#).

Natasha Higgitt

Heritage Officer: Archaeology, Palaeontology and Meteorites Unit

South African Heritage Resources Agency
- A nation united through heritage -

T: +27 21 462 4502/ 8660 | C:+27 82 507 0378 | F:+27 21 462 4509
E: nhiggitt@sahra.org.za | 111 Harrington Street | Cape Town |

www.sahra.org.za

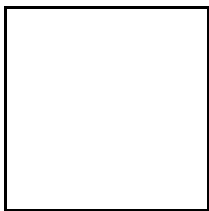

Disclaimer

The information contained in this communication from the sender is confidential. It is intended solely for use by the recipient and others authorized to receive it. If you are not the recipient, you are hereby notified that any disclosure, copying, distribution or taking action in relation of the contents of this information is strictly prohibited and may be unlawful.

This email has been scanned for viruses and malware, and automatically archived by **Mimecast SA (Pty) Ltd**, an innovator in Software as a Service (SaaS) for business. **Mimecast Unified Email Management ??? (UEM)** offers email continuity, security, archiving and compliance with all current legislation. To find out more, [contact Mimecast](#).

Natasha Higgitt

Heritage Officer: Archaeology, Palaeontology and Meteorites Unit

South African Heritage Resources Agency
- A nation united through heritage -

T: +27 21 462 4502/ 8660 | C:+27 82 507 0378 | F:+27 21 462 4509
E: nhiggitt@sahra.org.za | 111 Harrington Street | Cape Town |

www.sahra.org.za



an agency of the
Department of Arts and Culture

OUR VALUES: Accountability, Teamwork & co-operation, Respect, Transparency, Service Excellency, Integrity & Ethics, Professionalism, Accessibility, Communication & Trust.



Nonyameko Mlungwana

Content Moderator: National Inventory Unit

South African Heritage Resources Agency
- A nation united through heritage -

T: +27 21 462 4502/ 8643 | C: | F:+27 21 4624509
E: NMlungwana@sahra.org.za | 111 Harrington Street | Cape Town |

www.sahra.org.za

Stephan Jacobs

From: Stephan Jacobs <stephanj@sivest.co.za>
Sent: Thursday, 20 February 2020 10:55 AM
To: Nondwe.Mdekazi@dedia.gov.za; ilitha09@gmail.com
Cc: Liandra Scott-Shaw; sivest_PPP; Hlengiwe Ntuli
Subject: BA Processes for construction of two (2) grid infrastructure developments (substations and power lines) near Middelburg in the Eastern Cape Province
Attachments: Mimecast Large File Send Instructions

I'm using Mimecast to share large files with you. Please see the attached instructions.

Dear Nondwe,

- **BASIC ASSESSMENT (EIA) FOR THE PROPOSED DEVELOPMENT OF THE WONDERHEUVEL ON-SITE ESKOM SUBSTATION, ESKOM COLLECTOR SUBSTATION AND ASSOCIATED 132KV POWER LINE NEAR NOUPOORT AND MIDDELBURG IN THE NORTHERN AND EASTERN CAPE PROVINCES (WONDERHEUVEL GRID)**
- **BASIC ASSESSMENT (EIA) FOR THE PROPOSED DEVELOPMENT OF THE PAARDE VALLEY ON-SITE ESKOM SUBSTATIONS, ESKOM COLLECTOR SUBSTATION AND ASSOCIATED 132KV POWER LINE NEAR NOUPOORT AND MIDDELBURG IN THE NORTHERN AND EASTERN CAPE PROVINCES (PAARDE VALLEY GRID)**

- NEW APPLICATIONS FOR ENVIRONMENTAL AUTHORISATION (EA)

SiVEST has been appointed as the independent Environmental Assessment Practitioner (EAP) to undertake the Basic Assessment (EIA) processes for the proposed development of the above-mentioned grid infrastructure developments (on-site and collector substations and 132kV overhead power lines) near Middelburg in the Eastern Cape Province.

The above-mentioned proposed developments are located near the town of Middelburg in the Inxuba Yethemba Local Municipality within the Chris Hani District Municipality of the Eastern Cape Province.

The Application for Environmental Authorisation (EA) for the above-mentioned proposed developments were submitted to the Competent Authority (namely the National Department of Environment, Forestry and Fisheries - DEFF) on Thursday 13 February 2020. The DEFF's application form states that a copy of the application must be copied to the relevant Provincial Environmental Department(s) and thus we are also sending you a copy.

As such, please find herewith attached an electronic copies of the Applications for EA for the above-mentioned proposed developments. All appendices have been attached to the PDF copies of the application forms which are attached to this email.

Please do not hesitate to contact us should there be any issues or should you have any queries in this regard.

Stephan Jacobs

From: Stephan Jacobs <stephanj@sivest.co.za>
Sent: Thursday, 20 February 2020 10:47 AM
To: tmthombeni@ncpg.gov.za
Cc: Liandra Scott-Shaw; Hlengiwe Ntuli; sivest_PPP
Subject: BA Process for construction of three (3) grid infrastructure developments (substations and power lines) near Noupoort in the Northern Cape Province
Attachments: Mimecast Large File Send Instructions

I'm using Mimecast to share large files with you. Please see the attached instructions.

Good Afternoon Thulani,

I trust you are well.

- **BASIC ASSESSMENT (EIA) FOR THE PROPOSED DEVELOPMENT OF THE MOOI PLAATS ON-SITE ESKOM SUBSTATION, ESKOM COLLECTOR SUBSTATION AND ASSOCIATED 132KV POWER LINE NEAR NOUPOORT IN THE NORTHERN CAPE PROVINCE (MOOI PLAATS GRID)**
- **BASIC ASSESSMENT (EIA) FOR THE PROPOSED DEVELOPMENT OF THE WONDERHEUVEL ON-SITE ESKOM SUBSTATION, ESKOM COLLECTOR SUBSTATION AND ASSOCIATED 132KV POWER LINE NEAR NOUPOORT AND MIDDELBURG IN THE NORTHERN AND EASTERN CAPE PROVINCES (WONDERHEUVEL GRID)**
- **BASIC ASSESSMENT (EIA) FOR THE PROPOSED DEVELOPMENT OF THE PAARDE VALLEY ON-SITE ESKOM SUBSTATIONS, ESKOM COLLECTOR SUBSTATION AND ASSOCIATED 132KV POWER LINE NEAR NOUPOORT AND MIDDELBURG IN THE NORTHERN AND EASTERN CAPE PROVINCES (PAARDE VALLEY GRID)**

- NEW APPLICATIONS FOR ENVIRONMENTAL AUTHORISATION (EA)

SiVEST has been appointed as the independent Environmental Assessment Practitioner (EAP) to undertake the Basic Assessment (EIA) processes for the proposed development of the above-mentioned grid infrastructure developments (on-site and collector substations and 132kV overhead power lines) near Noupoort and Middelburg in the Northern and Eastern Cape Provinces.

The above-mentioned proposed developments are located near the town of Noupoort in the Umsobomvu Local Municipality, in the Pixley ka Seme District Municipality of the Northern Cape Province. The Wonderheuveld and Paarde Valley Grid projects are also located near Middelburg in the Inxuba Yethemba Local Municipality within the Chris Hani District Municipality of the Eastern Cape Province. We have however also forwarded these applications to the Eastern Cape Department of Economic Development, Environmental Affairs and Tourism (EC DEDEAT).

The Application for Environmental Authorisation (EA) for the above-mentioned proposed developments were submitted to the Competent Authority (namely the National Department of Environment, Forestry and Fisheries - DEFF) on Thursday 13 February 2020. The DEFF's application form states that a copy of the application must be copied to the relevant Provincial Environmental Department(s) and thus we are also

sending you a copy. As mentioned above, we have also forwarded the Wonderheuvel and Paarde Valley applications to the EC DEDEAT.

As such, please find herewith attached an electronic copies of the Applications for EA for the above-mentioned proposed developments. All appendices have been attached to the PDF copy of the application form which is attached to this email.

Please do not hesitate to contact us should there be any issues or should you have any queries in this regard.

Kind Regards,

Stephan Jacobs

SiVEST Environmental Division

011 798 0600

072 737 2114

Stephan Jacobs

From: Stephan Jacobs
Sent: Thursday, 27 February 2020 12:54 PM
To: 'Natasha Higgitt'
Cc: 'sahrisadmin@sahra.org.za'; Liandra Scott-Shaw; Hlengiwe Ntuli
Subject: RE: New private message from SAHRIS: SAHRIS Case ID 14884 and 14885

Importance: High

| Tracking: | Recipient | Delivery |
|-----------|----------------------------|--------------------------------|
| | 'Natasha Higgitt' | |
| | 'sahrisadmin@sahra.org.za' | |
| | Liandra Scott-Shaw | Delivered: 2020/02/27 12:54 PM |
| | Hlengiwe Ntuli | Delivered: 2020/02/27 12:54 PM |

Good Afternoon Natasha,

I trust you are well.

The email below refers.

Please be advised that SiVEST have mapped the development footprints for SAHRIS Case ID **14884** and **14885**, as requested. In addition, we have also changed the status of the case applications to SUBMITTED. Please advise if it should be changed back to DRAFT. I was not sure.

Please note that SiVEST are having issues mapping the development footprint for the Paarde Valley Grid Project (SAHRIS Case ID **14944**). We accidentally uploaded the incorrect KML for this and it doesn't want to display the correct development footprint, even though I removed the incorrect KML and re-uploaded the correct one. Please can SAHRA assist in this regard?

Do not hesitate to contact us should there be any issues or should you have any queries.

Kind Regards,

Stephan Jacobs (B.Sc. (Hons) Environmental Management and Analysis)
Environmental Consultant / Visual Specialist
SiVEST Environmental Division



SiVEST is a Level 3 BBBEE Contributor

D +27 11 798 0677 | **T** +27 011 798 0600 | **M** +27 72 737 2114 **E** stephanj@sivest.co.za | **W** www.sivest.co.za

Engineering Consulting | Project Management | Environmental Consulting | Town & Regional Planning | Management Systems

Consulting

Durban | Johannesburg | Pretoria | Pietermaritzburg | Richards Bay | Port Louis (Mauritius)

From: sahrisadmin@sahra.org.za [mailto:sahrisadmin@sahra.org.za]

Sent: Thursday, 27 February 2020 10:38 AM

To: Hlengiwe Ntuli <HlengiweN@sivest.co.za>

Subject: New private message from SAHRIS: SAHRIS Case ID 14884 and 14885

Hi andrea.gibb,

This is an automatic reminder from the site SAHRA. You have received a new private message from natasha.higgitt.

To read your message on SAHRIS,
First LOGIN TO SAHRIS
then, follow this link:

<https://sahris.sahra.org.za/messages/view/25500>

Alternatively, login to SAHRIS and navigate to www.sahra.org.za/messages

The body of your message reads:

Good morning,

Please note that the location of the developments for SAHRIS Case ID 14884 and 14885 have not been mapped. Please upload a kml file to the third page of each application as soon as possible. I cannot issue any comments on an incomplete application.

Regards,
Natasha Higgitt

If you don't want to receive these emails again, change your preferences here:

<https://sahris.sahra.org.za/user/2486/edit>

Please do not reply to this automated message as it is generated by the system account.

Stephan Jacobs

From: Stephan Jacobs
Sent: Friday, 28 February 2020 8:54 AM
To: 'Natasha Higgitt'
Cc: Liandra Scott-Shaw; Hlengiwe Ntuli
Subject: RE: Paarde Valley Substations and Power Line near Noupoot and Middelburg in the Northern and Eastern Cape Provinces (): SAHRIS Case Created
Attachments: RE: New private message from SAHRIS: SAHRIS Case ID 14884 and 14885
Importance: High

Good Morning Natasha,

Noted, thank you for informing us. Will wait to hear back from you in this regard.

Please note that the development footprint for the Paarde Valley Grid Project (SAHRIS Case ID **14944**) as it shows on the SAHRIS page is not correct. We accidentally uploaded the incorrect KML for this yesterday and it doesn't want to display the correct development footprint, even though I removed the incorrect KML and re-uploaded the correct one. I sent SAHRIS an email in this regard yesterday (see attached). The KML file which was uploaded should however be correct (I downloaded it off the SAHRIS page yesterday and checked and it is correct. It just keeps displaying the wrong footprint on the SAHRIS page for some reason).

Let me know if you need me to send you a KML of the Paarde Valley Grid footprint directly, should there be any issues with the KML file uploaded to SAHRIS.

Apologies for the inconvenience.

Please do not hesitate to contact us should there be any issues.

Kind Regards,

Stephan Jacobs (*B.Sc. (Hons) Environmental Management and Analysis*)
Environmental Consultant / Visual Specialist
SiVEST Environmental Division



SiVEST is a Level 3 BBBEE Contributor

D +27 11 798 0677 | **T** +27 011 798 0600 | **M** +27 72 737 2114 **E** stephanj@sivest.co.za | **W** www.sivest.co.za

Engineering Consulting | Project Management | Environmental Consulting | Town & Regional Planning | Management Systems Consulting
Durban | Johannesburg | Pretoria | Pietermaritzburg | Richards Bay | Port Louis (Mauritius)

From: Natasha Higgitt [mailto:nhiggitt@sahra.org.za]
Sent: Friday, 28 February 2020 8:06 AM
To: Stephan Jacobs <StephanJ@sivest.co.za>
Cc: Liandra Scott-Shaw <LiandraS@sivest.co.za>; Hlengiwe Ntuli <HlengiweN@sivest.co.za>
Subject: RE: Paarde Valley Substations and Power Line near Noupoot and Middelburg in the Northern and Eastern Cape Provinces (): SAHRIS Case Created

Good morning,

Thank you for the notification. I have assigned myself to Paarde Valley and I have completed the comments for all three cases. They have been sent for the usual internal review and I will inform you once the comments have been issued.

Kind regards,

From: Stephan Jacobs <StephanJ@sivest.co.za>
Sent: Thursday, 27 February 2020 12:31
To: Natasha Higgitt <nhiggitt@sahra.org.za>
Cc: Liandra Scott-Shaw <LiandraS@sivest.co.za>; Hlengiwe Ntuli <HlengiweN@sivest.co.za>
Subject: Paarde Valley Substations and Power Line near Noupoort and Middelburg in the Northern and Eastern Cape Provinces (): SAHRIS Case Created
Importance: High

Good Afternoon Natasha,

I trust you are well.

Please be advised that SIVEST created case applications on SAHRIS for the Mooi Plaats (Case ID **14884**) and Wonderheuvel (Case ID **14885**) Substation and Power Line projects (i.e. the grid projects), however, a case application was never created for the Paarde Valley grid project. Apologies for this. The Paarde valley grid project crosses the Eastern and Northern Cape Provincial boundaries and thus I believe SAHRA will need to comment on the project as SAHRA comments on developments in the Northern Cape Province.

Please note that a case application has now been created for the Paarde valley Substation and Power Line project (i.e. Paarde valley Grid) and the following Case ID has been allocated: **14944**.

Please note that the ECPHRA are also being consulted in order to provide comments on the Wonderheuvel and Paarde Valley Grid projects, as they cross into the Eastern Cape Province.

I trust you will find everything is in order.

Apologies for any inconvenience this might have caused.

Please do not hesitate to contact us should there be any issues or should you require any further information.

Kind Regards,

Stephan Jacobs (*B.Sc. (Hons) Environmental Management and Analysis*)
Environmental Consultant / Visual Specialist
SiVEST Environmental Division



SiVEST is a Level 3 BBBEE Contributor

D +27 11 798 0677 | T +27 011 798 0600 | M +27 72 737 2114 E stephanj@sivest.co.za | W www.sivest.co.za

Engineering Consulting | Project Management | Environmental Consulting | Town & Regional Planning | Management Systems Consulting

Durban | Johannesburg | Pretoria | Pietermaritzburg | Richards Bay | Port Louis (Mauritius)

Disclaimer

The information contained in this communication from the sender is confidential. It is intended solely for use by the recipient and others authorized to receive it. If you are not the recipient, you are hereby notified that any disclosure, copying, distribution or taking action in relation of the contents of this information is strictly prohibited and may be unlawful.

This email has been scanned for viruses and malware, and automatically archived by **Mimecast SA (Pty) Ltd**, an innovator in Software as a Service (SaaS) for business. **Mimecast Unified Email Management ??? (UEM)** offers email continuity, security, archiving and compliance with all current legislation. To find out more, [contact Mimecast](#).

Natasha Higgitt

Heritage Officer: Archaeology, Palaeontology and Meteorites Unit

South African Heritage Resources Agency

- A nation united through heritage -

T: +27 21 462 4502/ 8660 | C: +27 82 507 0378 | F: +27 21 462 4509

E: nhiggitt@sahra.org.za | 111 Harrington Street | Cape Town |

www.sahra.org.za



OUR VALUES: Accountability, Teamwork & co-operation, Respect, Transparency, Service Excellency, Integrity & Ethics, Professionalism, Accessibility, Communication & Trust.

BREAK THE CORRUPTION CHAIN
REPORT FRAUD & CORRUPTION: 0800 701 701



an agency of the
Department of Arts and Culture

UNMASK THE CORRUPT



Stephan Jacobs

From: Stephan Jacobs
Sent: Thursday, 12 March 2020 9:27 AM
To: 'Natasha Higgitt'
Cc: Liandra Scott-Shaw; 'Sheldon.vandrey@edf-re.co.za'; Hlengiwe Ntuli; sivest_PPP
Subject: RE: 15324 Three (3) Grid Infrastructure Projects (Substations and Power Lines) near Noupoort and Middelburg: DBAR Comment Period Ends

Good Morning,

Final Comment Letters received. Thank you very much for these.

Kind Regards,

Stephan Jacobs (B.Sc. (Hons) Environmental Management and Analysis)
Environmental Consultant / Visual Specialist
SiVEST Environmental Division



SiVEST is a Level 3 BBBEE Contributor

D +27 11 798 0677 | **T** +27 011 798 0600 | **M** +27 72 737 2114 **E** stephanj@sivest.co.za | **W** www.sivest.co.za

Engineering Consulting | Project Management | Environmental Consulting | Town & Regional Planning | Management Systems Consulting
Durban | Johannesburg | Pretoria | Pietermaritzburg | Richards Bay | Port Louis (Mauritius)

From: Natasha Higgitt [mailto:nhiggitt@sahra.org.za]
Sent: Thursday, 12 March 2020 9:23 AM
To: sivest_PPP <sivest_ppp@sivest.co.za>
Cc: Stephan Jacobs <StephanJ@sivest.co.za>; Liandra Scott-Shaw <LiandraS@sivest.co.za>; 'Sheldon.vandrey@edf-re.co.za' <Sheldon.vandrey@edf-re.co.za>
Subject: RE: 15324 Three (3) Grid Infrastructure Projects (Substations and Power Lines) near Noupoort and Middelburg: DBAR Comment Period Ends

Good morning,

Please note that Final Comments have been issued on SAHRIS Case ID 14884, 14885 and 14944. Please see links to the cases:

<https://sahris.sahra.org.za/cases/mooi-plaats-grid-ba>
<https://sahris.sahra.org.za/cases/wonderheuvel-grid-ba>
<https://sahris.sahra.org.za/cases/paarde-valley-grid-ba>

Kind regards,

From: sivest_PPP <sivest_ppp@sivest.co.za>
Sent: Wednesday, 11 March 2020 11:53
Cc: Stephan Jacobs <StephanJ@sivest.co.za>; Liandra Scott-Shaw <LiandraS@sivest.co.za>; 'Sheldon.vandrey@edf-

re.co.za' <Sheldon.vandrey@edf-re.co.za>

Subject: 15324 Three (3) Grid Infrastructure Projects (Substations and Power Lines) near Noupoort and Middelburg:
DBAR Comment Period Ends

Importance: High

Dear Interested and/or Affected Party (I&AP) / Stakeholder,

BASIC ASSESSMENTS (BAS) FOR THE PROPOSED DEVELOPMENT OF THE THREE (3) GRID CONNECTION INFRASTRUCTURE DEVELOPMENTS (SUBSTATIONS AND POWER LINES) NEAR NOUPOORT AND MIDDELBURG IN THE NORTHERN AND EASTERN CAPE PROVINCES

- **MOOI PLAATS GRID – (DEA Ref No.: 14/12/16/3/3/1/2132)**
- **WONDERHEUVEL GRID – (DEA Ref No.: 14/12/16/3/3/1/2134)**
- **PAARDE VALLEY GRID – (DEA Ref No.: 14/12/16/3/3/1/2133)**

Please note that the Draft Basic Assessment Reports (DBARs) for the above-mentioned projects were made available for public review and comment from **Monday the 10th of February 2020** to **Wednesday the 11th of March 2020** (end of business day). The review and comment periods for the above-mentioned projects therefore end today, **Wednesday the 11th of March 2020** (end of business day).

SiVEST therefore wish to remind you to submit comments for the above-mentioned projects (where required). If possible, please submit all comments before or by **13:00 on Thursday 12 March 2020**.

Should you have any comments, please feel free to contact the public participation office at the details below:

SiVEST Environmental

PO Box 2921, RIVONIA, 2128

Phone: (011) 798 0600

E-mail: hlangiwen@sivest.co.za / sivest_ppp@sivest.co.za

Fax: (011) 803 7272

We would like to thank you in anticipation of your active and meaningful contribution to the BA and public participation process.

Kind Regards,

Geagte Belangstellende en/of Geaffekteerde Party / Belanghebbende,

BASIESE EVALUERINGSPROSESSE (BE-PROSESSE) VIR DIE BEOOGDE ONTWIKKELING VAN DIE MOOI PLAATS, WONDERHUEVEL EN PAARDE VALLEY SUBSTASIES EN GEASSOSIEERDE 132KV KRAGLYNE NABY NOUPOORT EN MIDDELBURG IN DIE NOORD- EN OOS-KAAPPROVINSIES

- **MOOI PLAATS SUBSTASIE EN KRAGLYN – (DO-verw. No.: 14/12/16/3/3/1/2132)**
- **WONDERHEUVEL SUBSTASIE EN KRAGLYN – (DO-verw. No.: 14/12/16/3/3/1/2134)**
- **PAARDE VALLEY SUBSTASIES EN KRAGLYN – (DO-verw. No.: 14/12/16/3/3/1/2133)**

Neem asseblief kennis dat die Konsep Basiese Evaleuringsverslae (KBEVs) vir die bogenoemde projekte vanaf **Maandag 10 Februarie 2020** tot **Woensdag 11 Maart 2020** (teen sluitingstyd) beskikbaar gestel was vir openbare oorsig en kommentaar. Die oorsig- en kommentaarperiodes vir die bogenoemde projekte eindig dus vandag, **Woensdag 11 Maart 2020** (teen sluitingstyd).

SiVEST wil u dus herinner om kommentaar vir die bogenoemde projekte te lewer (waar nodig). Indien moontlik, lewer asseblief alle kommentaar voor of teen **13:00 op Donderdag 12 Maart 2020**.

Indien u enige kommentaar het, kan u die kantoor vir openbare deelname kontak met die onderstaande besonderhede:

SiVEST Omgewingsafdeling

Posbus 2921, RIVONIA, 2128

Foon: (011) 798 0600
E-pos: hlengiwen@sivest.co.za / sivest_ppp@sivest.co.za
Faks: (011) 803 7272

Ons dank u byvoorbaat vir u aktiewe en betekenisvolle bydrae tot die BE en Openbare Deelnameprosesse.

Vriendelike groete,

Stephan Jacobs (*B.Sc. (Hons) Environmental Management and Analysis*)
Environmental Consultant / Visual Specialist
SIVEST Environmental Division

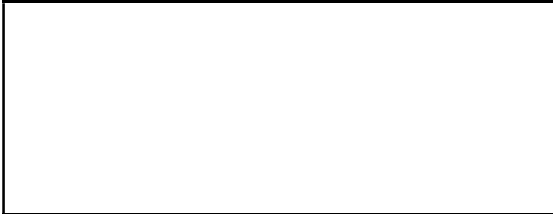

SIVEST is a Level 3 BBBEE Contributor

D +27 11 798 0677 | **T** +27 011 798 0600 **E** stephanj@sivest.co.za | **W** www.sivest.co.za
Engineering Consulting | Project Management | Environmental Consulting | Town & Regional Planning | Management Systems Consulting
Durban | Johannesburg | Pretoria | Pietermaritzburg | Richards Bay | Port Louis (Mauritius)

From: sivest_PPP
Sent: 03 March 2020 04:28 PM
Cc: Stephan Jacobs <StephanJ@sivest.co.za>; Liandra Scott-Shaw <LiandraS@sivest.co.za>; 'Sheldon.vandrey@edf-re.co.za' <Sheldon.vandrey@edf-re.co.za>
Subject: RE: 15324 Three (3) Solar PV Energy Facilities and Grid Infrastructures near Noupoort and Middelburg: DBAR Comment Period Ending
Importance: High

Dear Interested and/or Affected Party (I&AP) / Stakeholder,

BASIC ASSESSMENTS (BAs) FOR THE PROPOSED DEVELOPMENT OF THE THREE (3) GRID CONNECTION INFRASTRUCTURE DEVELOPMENTS (SUBSTATIONS AND POWER LINES) NEAR NOUPOORT AND MIDDELBURG IN THE NORTHERN AND EASTERN CAPE PROVINCES

- Mooi Plaats Grid – (DEA Ref No: To be announced)
- Wonderheuvel Grid – (DEA Ref No: To be announced)
- Paarde Valley Grid – (DEA Ref No: To be announced)

Please note that the Draft Basic Assessment Reports (DBARs) for the above-mentioned projects were made available for public review and comment from **Monday the 10th of February 2020 to Wednesday the 11th of March 2020** (end of business day). The review and comment periods for the above-mentioned projects therefore end next week on **Wednesday the 11th of March 2020** (end of business day).

SiVEST therefore wish to remind you to submit comments for the above-mentioned projects (where required). If possible, please submit all comments before or by **Wednesday the 11th of March 2020** (end of business day).

Should you have any comments, please feel free to contact the public participation office at the details below:

SiVEST Environmental

PO Box 2921, RIVONIA, 2128

Phone: (011) 798 0600

E-mail: hlangiwen@sivest.co.za / sivest_ppp@sivest.co.za

Fax: (011) 803 7272

We would like to thank you in anticipation of your active and meaningful contribution to the BA and public participation process.

Kind Regards,

Hlangiwe Ntuli

Projects Secretary and PPP Administrator

SiVEST



SiVEST is a Level 3 BBBEE Contributor

D +27 11 798 0690 | **T** +27 11 798 0600 | **E** HlangiweN@sivest.co.za | **W** www.sivest.co.za

Engineering Consulting | Project Management | Environmental Consulting | Town & Regional Planning | Management Systems Consulting

Durban | Johannesburg | Pretoria | Pietermaritzburg | Richards Bay | Port Louis (Mauritius)

From: sivest_PPP

Sent: 10 February 2020 05:04 PM

Cc: Stephan Jacobs <StephanJ@sivest.co.za>; Liandra Scott-Shaw <LiandraS@sivest.co.za>; 'Sheldon.vandrey@edf-re.co.za' <Sheldon.vandrey@edf-re.co.za>

Subject: 15324 Three (3) Solar PV Energy Facilities and Grid Infrastructures near Noupoort and Middelburg: DBAR Comment Period Starting

Dear Interested and/or Affected Party (I&AP),

BASIC ASSESSMENTS (BAs) FOR THE PROPOSED DEVELOPMENT OF THE THREE (3) GRID CONNECTION INFRASTRUCTURE DEVELOPMENTS (SUBSTATIONS AND POWER LINES) NEAR NOUPOORT AND MIDDELBURG IN THE NORTHERN AND EASTERN CAPE PROVINCES

- **Mooi Plaats Grid – (DEA Ref No: To be announced)**
- **Wonderheuvel Grid – (DEA Ref No: To be announced)**
- **Paarde Valley Grid – (DEA Ref No: To be announced)**

Please note that SiVEST SA (Pty) Ltd has been appointed as the independent Environmental Assessment Practitioner (EAP) to undertake the Basic Assessment (BA) processes for the above-mentioned proposed projects.

We would like to take this opportunity to inform you that, in accordance with the National Environmental Management Act, 1998 (Act No. 107 of 1998) (NEMA) (as amended), the Draft Basic Assessment Reports (DBARs) for the above-mentioned proposed projects will be available for public comment and review as from **Monday the 10th of February**

2020 to Wednesday the 11th of March 2020 (end of business day). Should you wish to receive an electronic copy of the DBARs (on CD), please forward your request in writing to us. Comments can be submitted to:

Hlengiwe Ntuli

PO Box 2921, RIVONIA, 2128

Phone: (011) 798 0600

E-mail: sivest_ppp@sivest.co.za / hlengiwen@sivest.co.za / stephanj@sivest.co.za

Fax: (011) 803 7272

Hard copies of the DBARs can be reviewed at the following public places:

| VENUE | REPORT(S) | STREET ADDRESS | HOURS | CONTACT NO |
|---------------------------|-------------------------|-------------------------------------------|----------------------------------------------------------------|-----------------|
| Noupoort Public Library | Mooi Plaats Grid DBAR | Shaw St, Noupoort, 5950 | Mondays - Fridays 10:00 - 13:00 13:45 - 16:30 | 049 843 1056 |
| | Wonderheuvel Grid DBAR | | Mondays - Fridays 09:00 - 16:30 | 049 802 1300 |
| Middelburg Public Library | Paarde Valley Grid DBAR | 47 Van Reenen Street, Middelburg, 5900 | | |
| | | | | |

The reports as well as the accompanying appendices are also available on SiVEST's website: <http://www.sivest.co.za/>, click on 'Downloads', then browse to the folder '15324 Umsobomvu PV and Grid'. Please reference 'Mooi Plaats / Wonderheuvel / Paarde Valley Grid' in your correspondence, should your comments be project specific.

We would like to thank you in anticipation of your active and meaningful contribution to the BA and public participation processes.

Geagte Belangstellende en/of Geaffekteerde Party,

BASIESE EVALUERINGS (BEs) VIR DIE BEOOGDE ONTWIKKELING VAN DIE DRIE (3) NETWERKVERBINDINGSINFRASTRUKTUURONTWIKKELINGS (SUBSTASIES EN KRAGLYNE) NABY NOUPOORT EN MIDDELBURG IN DIE NOORD- EN OOS-KAAPPROVINSIES

- MOOI PLAATS SUBSTASIES EN KRAGLYN – (DO-verw. No.: Moet nog aangekondig word)
- WONDERHEUVEL SUBSTASIES EN KRAGLYN – (DO-verw. No.: Moet nog aangekondig word)
- PAARDE VALLEY SUBSTASIES EN KRAGLYN – (DO-verw. No.: Moet nog aangekondig word)

Ons stel u graag in kennis dat SiVEST SA (Edms) Bpk aangestel is as die onafhanklike Omgewingsevalueringpraktisyn (OEP) om die Basiese Evaluering- (BE) prosesse vir die bogenoemde voorgestelde projekte te onderneem.

Ons wil graag van hierdie geleentheid gebruik maak om u in te lig dat ingevolge die Nasionale Wet op Omgewingsbestuur (NEMA) (Wet No. 107 van 1998) (soos gewysig), sal die Konsep Basiese Evalueringverslae (KBEVs) vir die bogenoemde voorgestelde projekte vanaf **Maandag 10 Februarie 2020** tot **Woensdag 11 Maart 2020** (teen sluitingstyd) beskikbaar wees vir openbare kommentaar en insae. As u elektroniese kopie van die KBEVs (op CD) wil ontvang, moet u dit asseblief skriftelik by ons versoek. Kommentaar kan soos volg ingedien word:

Hlengiwe Ntuli

Posbus 2921, RIVONIA, 2128

Foon: (011) 798 0600

E-pos: sivest_ppp@sivest.co.za / hlengiwen@sivest.co.za / stephanj@sivest.co.za

Faks: (011) 803 7272

Gedrukte kopie van die KBEVs kan by die volgende openbare plekke nagegaan word:

| PLEK | VERSLAG / VERSLAE | STRAATADRES | TYE | KONTAKNOMMERS |
|--------------------------------------|-----------------------------------------------------------------------------------------------|------------------------------------------|---------------------------------------------------------------------|---------------|
| Noupoort Publieke Biblioteek | Mooi Plaats Substasie en Kraglyn KBEV | Shawstraat, Noupoort, 5950 | Maandae - Vrydae 10:00 - 13:00 13:45 - 16:30 | 049 843 1056 |
| Middelburg Publieke Biblioteek | Wonderheuvel Substasie en Kraglyn KBEV Paarde Valley Substasie en Kraglyn KBEV | Van Reenenstraat 47, Middelburg, 5900 | Maandae - Vrydae 09:00 - 16:30 | 049 802 1300 |

Die verslae, sowel as die meegaande aanhangsels, is ook beskikbaar op SiVEST se webwerf: <http://www.sivest.co.za/>, klik op 'Downloads' en soek dan vir die legger '15324 Umsobomvu PV and Grid'. Verwys asseblief 'Mooi Plaats / Wonderheuvel / Paarde Valley Grid' in u korrespondensie, indien u kommentaar spesifiek op die projek is.

Ons dank u byvoorbaat vir u aktiewe en betekenisvolle bydrae tot die BE en Openbare Deelnameprosesse.

Kind Regards,

Stephan Jacobs (B.Sc. (Hons) Environmental Management and Analysis)

Environmental Consultant / Visual Specialist

SiVEST Environmental Division

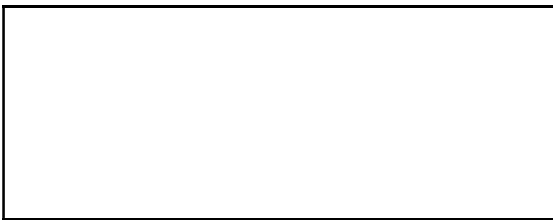

SiVEST is a Level 3 BBBEE Contributor

D +27 11 798 0677 | **T** +27 011 798 0600 **E** stephanj@sivest.co.za | **W** www.sivest.co.za

Engineering Consulting | Project Management | Environmental Consulting | Town & Regional Planning | Management Systems Consulting

Durban | Johannesburg | Pretoria | Pietermaritzburg | Richards Bay | Port Louis (Mauritius)

Natasha Higgitt

Heritage Officer: Archaeology, Palaeontology and Meteorites Unit

South African Heritage Resources Agency

- A nation united through heritage -

T: +27 21 462 4502/ 8660 | **C:** +27 82 507 0378 | **F:** +27 21 462 4509

E: nhiggitt@sahra.org.za | 111 Harrington Street | Cape Town |

www.sahra.org.za

Stephan Jacobs

From: Stephan Jacobs
Sent: Friday, 13 March 2020 11:11 AM
To: 'Mark Moodaley *Transnet Property PLZ'
Cc: Thandeka Nohoyeka Transnet Property PLZ; sivist_PPP; Hlengiwe Ntuli; Liandra Scott-Shaw
Subject: RE: 15324 Three (3) Solar PV Energy Facilities and Grid Infrastructures near Noupoot and Middelburg: DBAR Comment Period Ending
Attachments: 15324_MooiPlaats_GridConnection_15Oct2019.kmz; 15324_PaardeValley_GridConnection_23Oct2019.kmz; 15324_Wonderheuvél_GridConnection_23Oct2019.kmz; A3_15324_MG02_RouteAlignment_Reduced.jpg; A3_15324_PG02_RouteAlignment_Reduced.jpg; A3_15324_WG02_RouteAlignment_Reduced.jpg; 15324_MooiPlaatsPV_Layout_22102019.kmz; 15324_PaardeValleyPV_Layout_23102019.kmz; 15324_WonderheuvélPV_Layout_22102019.kmz; A3_15324_ME02_SiteLocality_Reduced.jpg; A3_15324_PE02_SiteLocality_Reduced.jpg; A3_15324_WE02_SiteLocality_Reduced.jpg; FW: 15324 Three (3) Solar PV Energy Facilities and Grid Infrastructures near Noupoot and Middelburg: DBAR Comment Period Ending
Importance: High

| Tracking: | Recipient | Delivery | Read |
|-----------|-----------------------------------------|--------------------------------|---------------------------|
| | 'Mark Moodaley *Transnet Property PLZ' | | |
| | Thandeka Nohoyeka Transnet Property PLZ | | |
| | sivist_PPP | Delivered: 2020/03/13 11:11 AM | Read: 2020/03/13 12:22 PM |
| | Hlengiwe Ntuli | Delivered: 2020/03/13 11:11 AM | Read: 2020/03/13 11:20 AM |
| | Liandra Scott-Shaw | Delivered: 2020/03/13 11:11 AM | Read: 2020/03/13 11:43 AM |

Good Morning Mr Moodaley,

I trust you are well.

The email below refers.

Thank you for your email. Apologies that the notice did not reach you timeously enough in order to provide supporting information to the relevant operating division for comment by 11 March 2020. Please be advised that SiVEST will only be submitting the Final Basic Assessments Reports (FBARs) for the three (3) grid projects (substations and power lines) at the end of March, therefore, we will provide you with additional time to comment. We can give you until the end of business day on Monday 23 March 2020 to provide comments in this regard. Would this be acceptable? Please advise should you require some more time.

As requested, please find attached KML files containing the data requested in your email below. These KMLs contain all the data requested below. SiVEST have also provided locality maps for the proposed solar PV and grid projects (substations and power lines), as this was also requested by Transnet (see attached email).

Please be advised that SiVEST will forward your comments with regards to the Solar , should you have any, to the competent authority (namely the DEA) for consideration.

We trust that you will find everything in order.

Please do not hesitate to contact us should there be any issues or should you have any further queries etc.

Kind Regards,

Stephan Jacobs (*B.Sc. (Hons) Environmental Management and Analysis*)
Environmental Consultant / Visual Specialist
SiVEST Environmental Division



SiVEST is a Level 3 BBBEE Contributor

D +27 11 798 0677 | **T** +27 011 798 0600 | **M** +27 72 737 2114 **E** stephanj@sivest.co.za | **W** www.sivest.co.za

Engineering Consulting | Project Management | Environmental Consulting | Town & Regional Planning | Management Systems Consulting
Durban | Johannesburg | Pretoria | Pietermaritzburg | Richards Bay | Port Louis (Mauritius)

From: Mark Moodaley *Transnet Property PLZ [mailto:Mark.Moodaley@transnet.net]
Sent: Tuesday, 10 March 2020 12:43 PM
To: sivest_PPP <sivest_ppp@sivest.co.za>
Cc: Thandeka Nohoyeka Transnet Property PLZ <Thandeka.Nohoyeka@transnet.net>
Subject: FW: 15324 Three (3) Solar PV Energy Facilities and Grid Infrastructures near Noupoort and Middelburg: DBAR Comment Period Ending
Importance: High

Good day,

The subject matter refers.

Kindly note that the notice did not reach us timeously enough for us to provide supporting information to the relevant operating division for comment by 11 March 2020 hence additional time will be required.

Further, it would be appreciated if the following data could be provide to us in CAD or Shape file format in order for us to determine what bearing (if any) this development will have on Transnet land:

1. Foot print of the three solar PV application sites.
2. The grid connection assessment corridors.
3. Proposed On-Site Substations.
4. Foot print of the renewable energy application sites (Solar and Wind).

Thanking you in anticipation.

Kind regards



Mark M Moodaley
Chief Property Technician
Transnet Property
Geo-Spatial: Central Region (Port Elizabeth)
+27 41 507 1319 +27 83 376 3024
+27 11 308 1308 +27 41 507 2884
mark.moodaley@transnet.net
www.transnet.net

From: Johannes Hanekom *Transnet Property CPT <Johannes.Hanekom@transnet.net>
Sent: 06 March 2020 02:56 PM
To: Mark Moodaley *Transnet Property PLZ <Mark.Moodaley@transnet.net>
Cc: Livhuwani Ndou Transnet Freight Rail JHB <Livhuwani.Ndou@transnet.net>; Burton Siljeur *Transnet Property CPT <Burton.Siljeur@transnet.net>
Subject: FW: 15324 Three (3) Solar PV Energy Facilities and Grid Infrastructures near Noupoort and Middelburg: DBAR Comment Period Ending
Importance: High

Good day Mark

Transnet land in the Western Region is not affected by this application.
Central Region office may need to investigate/ assist if they are affected or not.
Please find attached which has been downloaded, for your attention.

With thanks.

Regards



Jaco Hanekom
Senior Property Technician
Geo-Spatial: Western Region
Transnet Property
+27 21 449 4529
Johannes.Hanekom@Transnet.net
www.transnet.net

From: Livhuwani Ndou Transnet Freight Rail JHB
Sent: 04 March 2020 12:13 PM
To: Sam Fiff Transnet Freight Rail BLM; Norman Papenfus Transnet Freight Rail BLM; Johannes Hanekom *Transnet Property CPT; Andre Bodenstein *Transnet Property BLM
Cc: Zanele Manyathi Transnet Freight Rail JHB; Creselda Mangalana Transnet Freight Rail Johannesburg
Subject: FW: 15324 Three (3) Solar PV Energy Facilities and Grid Infrastructures near Noupoort and Middelburg: DBAR Comment Period Ending
Importance: High

Dear Colleagues,

Please review and comment on this proposal.

Kind regards,

Livhuwani

From: Ezekiel Monyamane Transnet Freight Rail JHB
Sent: 04 March 2020 08:31 AM
To: Livhuwani Ndou Transnet Freight Rail JHB <Livhuwani.Ndou@transnet.net>

Subject: FW: 15324 Three (3) Solar PV Energy Facilities and Grid Infrastructures near Noupoort and Middelburg:
DBAR Comment Period Ending
Importance: High

FYI

From: sivest_PPP [mailto:sivest_ppp@sivest.co.za]

Sent: 03 March 2020 04:28 PM

Cc: Stephan Jacobs; Liandra Scott-Shaw; 'Sheldon.vandrey@edf-re.co.za'

Subject: RE: 15324 Three (3) Solar PV Energy Facilities and Grid Infrastructures near Noupoort and Middelburg:
DBAR Comment Period Ending

Importance: High

Dear Interested and/or Affected Party (I&AP) / Stakeholder,

BASIC ASSESSMENTS (BAs) FOR THE PROPOSED DEVELOPMENT OF THE THREE (3) GRID CONNECTION INFRASTRUCTURE DEVELOPMENTS (SUBSTATIONS AND POWER LINES) NEAR NOUPOORT AND MIDDELBURG IN THE NORTHERN AND EASTERN CAPE PROVINCES

- **Mooi Plaats Grid – (DEA Ref No: To be announced)**
- **Wonderheuvel Grid – (DEA Ref No: To be announced)**
- **Paarde Valley Grid – (DEA Ref No: To be announced)**

Please note that the Draft Basic Assessment Reports (DBARs) for the above-mentioned projects were made available for public review and comment from **Monday the 10th of February 2020 to Wednesday the 11th of March 2020** (end of business day). The review and comment periods for the above-mentioned projects therefore end next week on **Wednesday the 11th of March 2020** (end of business day).

SiVEST therefore wish to remind you to submit comments for the above-mentioned projects (where required). If possible, please submit all comments before or by **Wednesday the 11th of March 2020** (end of business day).

Should you have any comments, please feel free to contact the public participation office at the details below:

SiVEST Environmental

PO Box 2921, RIVONIA, 2128

Phone: (011) 798 0600

E-mail: hlengiwen@sivest.co.za / sivest_ppp@sivest.co.za

Fax: (011) 803 7272

We would like to thank you in anticipation of your active and meaningful contribution to the BA and public participation process.

Kind Regards,

Hlengiwe Ntuli

Projects Secretary and PPP Administrator

SiVEST





SIVEST is a Level 3 BBBEE Contributor

D +27 11 798 0690| **T** +27 11 798 0600 | **E** HlengiweN@sivest.co.za | **W** www.sivest.co.za
Engineering Consulting | Project Management | Environmental Consulting | Town & Regional Planning | Management Systems Consulting
Durban | Johannesburg | Pretoria | Pietermaritzburg | Richards Bay | Port Louis (Mauritius)

From: sivest_PPP
Sent: 10 February 2020 05:04 PM
Cc: Stephan Jacobs <StephanJ@sivest.co.za>; Liandra Scott-Shaw <LiandraS@sivest.co.za>; 'Sheldon.vandrey@edf-re.co.za' <Sheldon.vandrey@edf-re.co.za>
Subject: 15324 Three (3) Solar PV Energy Facilities and Grid Infrastructures near Noupoort and Middelburg: DBAR Comment Period Starting

Dear Interested and/or Affected Party (I&AP),

BASIC ASSESSMENTS (BAs) FOR THE PROPOSED DEVELOPMENT OF THE THREE (3) GRID CONNECTION INFRASTRUCTURE DEVELOPMENTS (SUBSTATIONS AND POWER LINES) NEAR NOUPOORT AND MIDDELBURG IN THE NORTHERN AND EASTERN CAPE PROVINCES

- **Mooi Plaats Grid – (DEA Ref No: To be announced)**
- **Wonderheuvel Grid – (DEA Ref No: To be announced)**
- **Paarde Valley Grid – (DEA Ref No: To be announced)**

Please note that SIVEST SA (Pty) Ltd has been appointed as the independent Environmental Assessment Practitioner (EAP) to undertake the Basic Assessment (BA) processes for the above-mentioned proposed projects.

We would like to take this opportunity to inform you that, in accordance with the National Environmental Management Act, 1998 (Act No. 107 of 1998) (NEMA) (as amended), the Draft Basic Assessment Reports (DBARs) for the above-mentioned proposed projects will be available for public comment and review as from **Monday the 10th of February 2020 to Wednesday the 11th of March 2020** (end of business day). Should you wish to receive an electronic copy of the DBARs (on CD), please forward your request in writing to us. Comments can be submitted to:

Hlengiwe Ntuli
PO Box 2921, RIVONIA, 2128
Phone: (011) 798 0600
E-mail: sivest_ppp@sivest.co.za / hlengiwen@sivest.co.za / stephanj@sivest.co.za
Fax: (011) 803 7272

Hard copies of the DBARs can be reviewed at the following public places:

| VENUE | REPORT(S) | STREET ADDRESS | HOURS | CONTACT NO |
|---------------------------|------------------------|----------------------------------------|------------------------------------------------------------|--------------|
| Noupoort Public Library | Mooi Plaats Grid DBAR | Shaw St, Noupoort, 5950 | Mondays - Fridays 10:00 - 13:00 13:45 - 16:30 | 049 843 1056 |
| Middelburg Public Library | Wonderheuvel Grid DBAR | 47 Van Reenen Street, Middelburg, 5900 | Mondays - Fridays 09:00 - 16:30 | 049 802 1300 |

The reports as well as the accompanying appendices are also available on SiVEST's website: <http://www.sivest.co.za/>, click on 'Downloads', then browse to the folder '15324 Umsobomvu PV and Grid'. Please reference 'Mooi Plaats / Wonderheuvel / Paarde Valley Grid' in your correspondence, should your comments be project specific.

We would like to thank you in anticipation of your active and meaningful contribution to the BA and public participation processes.

Geagte Belangstellende en/of Geaffekteerde Party,

BASIESE EVALUERINGS (BEs) VIR DIE BEOOGDE ONTWIKKELING VAN DIE DRIE (3) NETWERKVERBINDINGSINFRASTRUKTUURONTWIKKELINGS (SUBSTASIES EN KRAGLYNE) NABY NOUPOORT EN MIDDELBURG IN DIE NOORD- EN OOS-KAAPROVINSIES

- **MOOI PLAATS SUBSTASIES EN KRAGLYN – (DO-verw. No.: Moet nog aangekondig word)**
- **WONDERHEUVEL SUBSTASIES EN KRAGLYN – (DO-verw. No.: Moet nog aangekondig word)**
- **PAARDE VALLEY SUBSTASIES EN KRAGLYN – (DO-verw. No.: Moet nog aangekondig word)**

Ons stel u graag in kennis dat SiVEST SA (Edms) Bpk aangestel is as die onafhanklike Omgewingsevalueringpraktisyn (OEP) om die Basiese Evaluering- (BE) prosesse vir die bogenoemde voorgestelde projekte te onderneem.

Ons wil graag van hierdie geleentheid gebruik maak om u in te lig dat ingevolge die Nasionale Wet op Omgewingsbestuur (NEMA) (Wet No. 107 van 1998) (soos gewysig), sal die Konsep Basiese Evalueringverslae (KBEVs) vir die bogenoemde voorgestelde projekte vanaf **Maandag 10 Februarie 2020** tot **Woensdag 11 Maart 2020** (teen sluitingstyd) beskikbaar wees vir openbare kommentaar en insae. As u elektroniese kopie van die KBEVs (op CD) wil ontvang, moet u dit asseblief skriftelik by ons versoek. Kommentaar kan soos volg ingedien word:

Hlengiwe Ntuli

Posbus 2921, RIVONIA, 2128

Foon: (011) 798 0600

E-pos: sivest_ppp@sivest.co.za / hlengiw@zivest.co.za / stephanj@sivest.co.za

Faks: (011) 803 7272

Gedrukte kopie van die KBEVs kan by die volgende openbare plekke nagegaan word:

| PLEK | VERSLAG / VERSLAE | STRAATADRES | TYE | KONTAKNOMMERS |
|--------------------------------------|-----------------------------------------------------------------------------------------|------------------------------------------|---------------------------------------------------------------------|---------------|
| Noupoort Publieke Biblioteek | Mooi Plaats Substasie en Kraglyn KBEV | Shawstraat, Noupoort, 5950 | Maandae - Vrydae 10:00 - 13:00 13:45 - 16:30 | 049 843 1056 |
| Middelburg Publieke Biblioteek | Wonderheuvel Substasie en Kraglyn KBEV Paarde Valley Substasie en Kraglyn KBEV | Van Reenenstraat 47, Middelburg, 5900 | Maandae - Vrydae 09:00 - 16:30 | 049 802 1300 |

Die verslae, sowel as die meegaande aanhangsels, is ook beskikbaar op SiVEST se webwerf: <http://www.sivest.co.za/>, klik op 'Downloads' en soek dan vir die legger '15324 Umsobomvu PV and Grid'. Verwys asseblief 'Mooi Plaats / Wonderheuvel / Paarde Valley Grid' in u korrespondensie, indien u kommentaar spesifiek op die projek is.

Ons dank u byvoorbeeld vir u aktiewe en betekenisvolle bydrae tot die BE en Openbare Deelnameprosesse.