





**AREA OF DRAINAGE STRUCTURES: PROPOSED NGCONCO ACCESS ROAD**

Name	Y coord	X Coord	Type	Precast Structure					IN- & OUT-let Structures			Total Area (m <sup>2</sup> )	Est. Excavation (m <sup>3</sup> )		
				Size	Diam (mm)	Length(m)	Barrels	Area (m <sup>2</sup> )	Type	Inlet (m <sup>2</sup> )	Outlet (m <sup>2</sup> )				
1	P01	-28.87573	30.48984	Precast Concrete Pipes	Ø600 pipe	700	9.46	2	17.60	Brick-600		4.37	4.37	26.34	29.56
2	P02	-28.87621	30.48881	Precast Concrete Pipes	Ø600 pipe	700	9.46	1	6.62	Brick-600		2.90	2.90	12.43	13.95
3	Slab 1	-28.87793	30.48601	Concrete Slab	25m X 6m	N/A			N/A			150.00	165.00		
4	P03	-28.87761	30.48448	Precast Concrete Pipes	Ø600 pipe	700	9.46	2	17.60	Brick-600		4.37	4.37	26.34	29.56
5	P04	-28.87730	30.48368	Precast Concrete Pipes	Ø600 pipe	700	9.46	1	6.62	Brick-600		2.90	2.90	12.43	13.95
6	P05	-28.87715	30.48329	Precast Concrete Pipes	Ø600 pipe	700	9.46	1	6.62	Brick-600		2.90	2.90	12.43	13.95
7	Slab 2	-28.87704	30.48277	Concrete Slab	45m X 6m	N/A			N/A			270.00	297.00		
8	P06	-28.87724	30.48073	Precast Concrete Pipes	Ø600 pipe	700	9.46	1	6.62	Brick-600		2.90	2.90	12.43	13.95
9	P07	-28.87677	30.47970	Precast Concrete Pipes	Ø600 pipe	700	9.46	1	6.62	Brick-600		2.90	2.90	12.43	13.95
10	P08	-28.87690	30.47898	Precast Concrete Pipes	Ø600 pipe	700	9.46	1	6.62	Brick-600		2.90	2.90	12.43	13.95
11	P09	-28.87694	30.47799	Precast Concrete Pipes	Ø600 pipe	700	9.46	1	6.62	Brick-600		2.90	2.90	12.43	13.95
12	P10	-28.87674	30.47727	Precast Concrete Pipes	Ø600 pipe	700	9.46	1	6.62	Brick-600		2.90	2.90	12.43	13.95
13	P11	-28.87606	30.47534	Precast Concrete Pipes	Ø900 pipe	1035	9.46	1	9.79	Brick-900		4.43	4.43	18.64	35.88
14	P12	-28.87657	30.47309	Precast Concrete Pipes	Ø600 pipe	700	9.46	1	6.62	Brick-600		2.90	2.90	12.43	13.95
15	P13	-28.87680	30.47146	Precast Concrete Pipes	Ø600 pipe	700	9.46	1	6.62	Brick-600		2.90	2.90	12.43	13.95
16	P14	-28.87684	30.47042	Precast Concrete Pipes	Ø600 pipe	700	9.46	1	6.62	Brick-600		2.90	2.90	12.43	13.95
17	P15	-28.87693	30.46794	Precast Concrete Pipes	Ø600 pipe	700	9.46	1	6.62	Brick-600		2.90	2.90	12.43	13.95
18	P16	-28.87656	30.46733	Precast Concrete Pipes	Ø600 pipe	700	9.46	1	6.62	Brick-600	2.90	2.90	12.43	13.95	
19	P17	-28.87817	30.46484	Precast Concrete Pipes	Ø600 pipe	700	9.46	1	6.62	Brick-600	2.90	2.90	12.43	13.95	
20	P18	-28.87936	30.46389	Precast Concrete Pipes	Ø600 pipe	700	9.46	1	6.62	Brick-600	2.90	2.90	12.43	13.95	
21	P19	-28.87911	30.46276	Precast Concrete Pipes	Ø600 pipe	700	9.46	1	6.62	Brick-600	2.90	2.90	12.43	13.95	
22	P20	-28.87785	30.46117	Precast Concrete Pipes	Ø600 pipe	700	9.46	1	6.62	Brick-600	2.90	2.90	12.43	13.95	
23	P21	-28.87696	30.46116	Precast Concrete Pipes	Ø600 pipe	700	9.46	1	6.62	Brick-600	2.90	2.90	12.43	13.95	

**Ø600 STORMWATER PIPE DIMENSIONS**

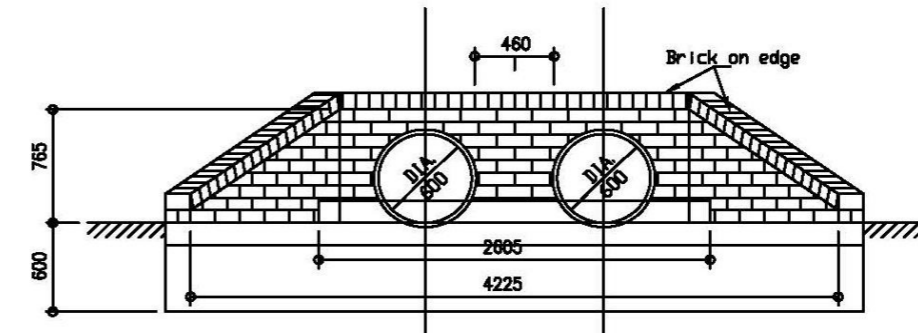
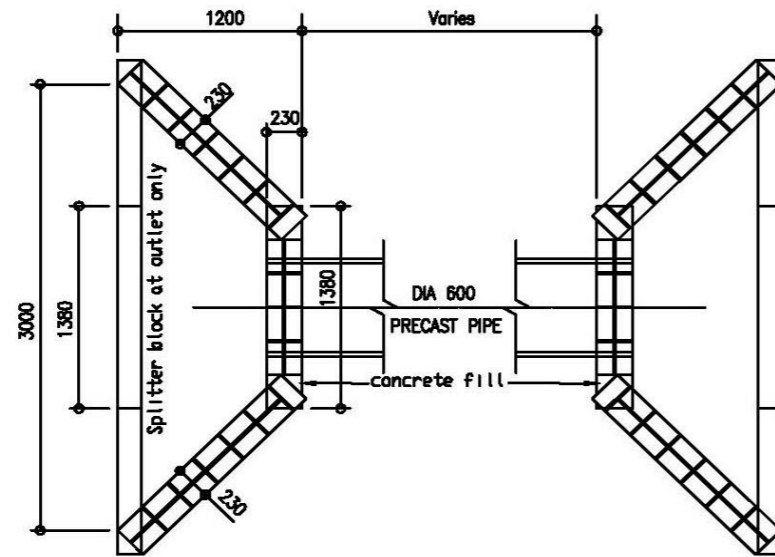
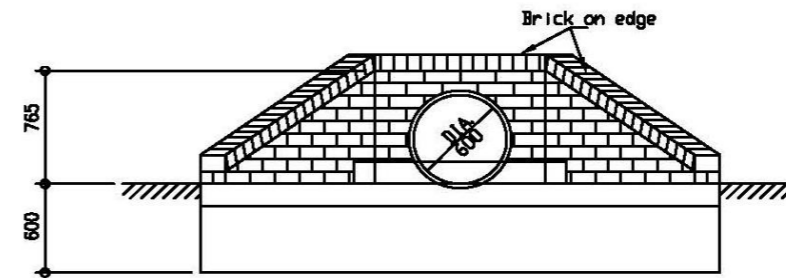
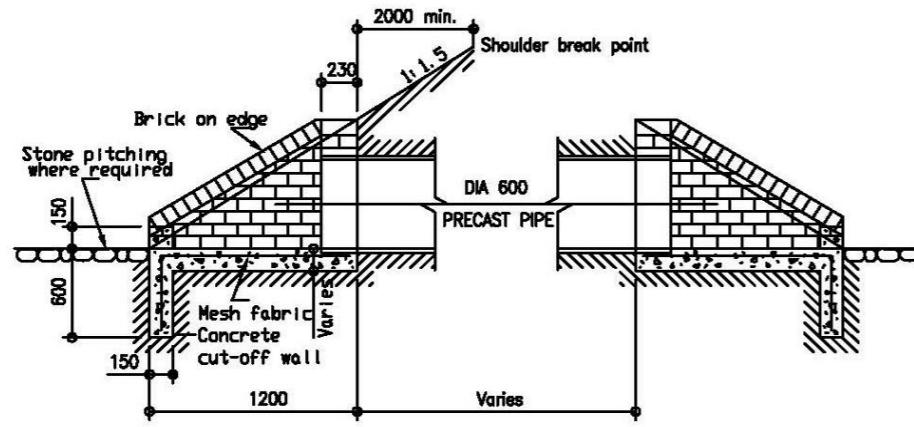

Not to scale

Not to scale

**Ø900 STORMWATER PIPE DIMENSIONS (NTS)**

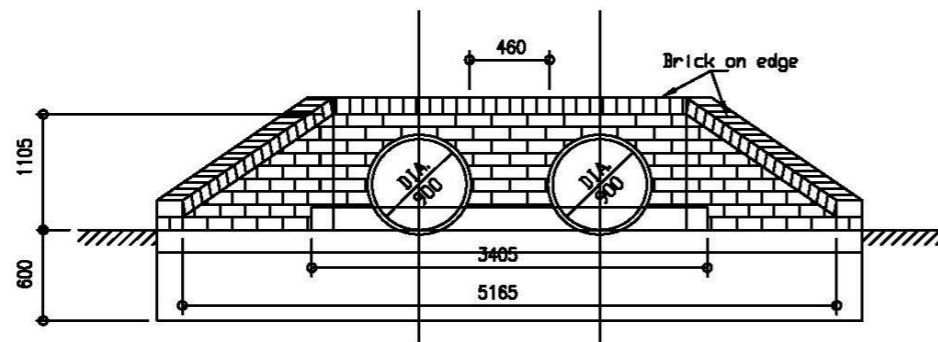
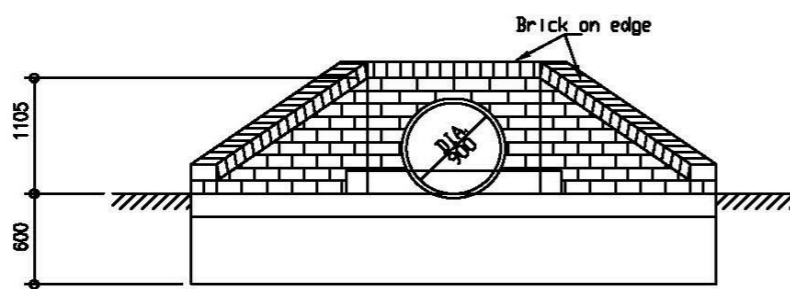
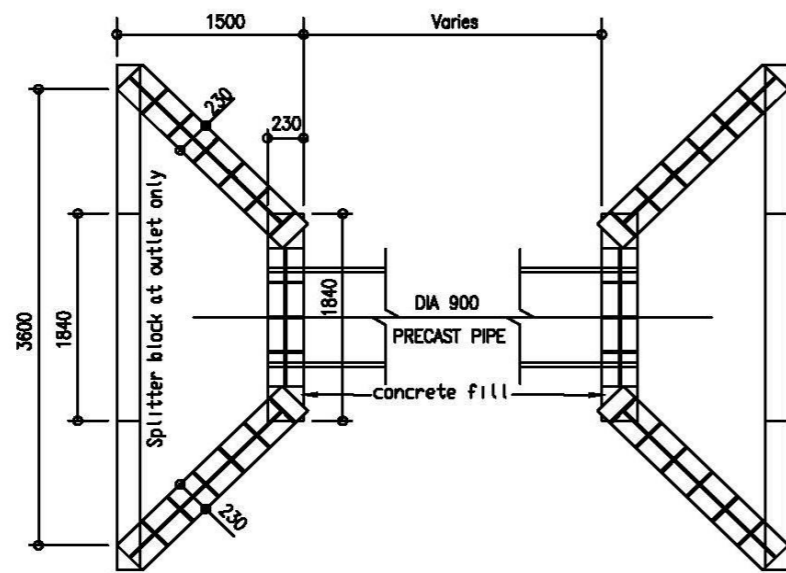
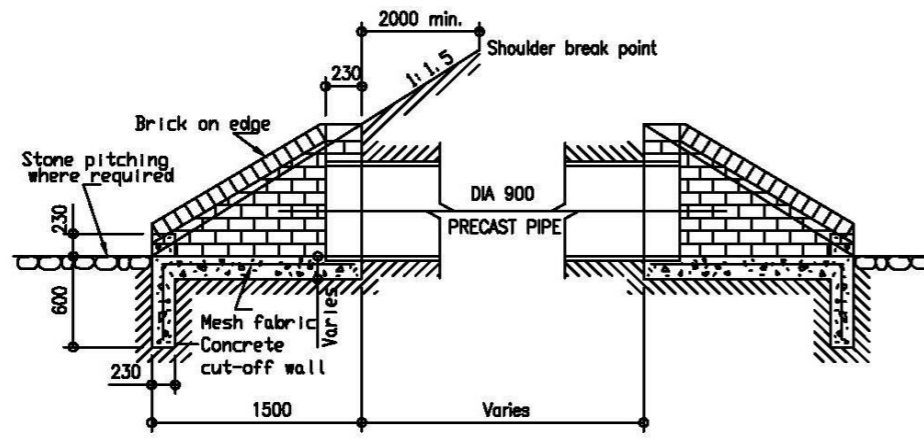

**Ø1200 STORMWATER PIPE DIMENSIONS (NTS)**

