

# NOISE COMPLIANCE STATEMENT AND SCREENING NOISE REPORT

for the Proposed Karusa Battery Energy Storage System and  
Associated Infrastructure located in the Northern Cape  
Province



*Statement done for:*

savannah  
environmental

*Prepared by:*

 **EARES**  
Enviro Acoustic Research

P.O. Box 2047, Garsfontein East, 0060  
Tel: 012 – 004 0362, Fax: 086 – 621 0292, E-mail: [info@eares.co.za](mailto:info@eares.co.za)

## **EXECUTIVE SUMMARY**

### **INTRODUCTION**

Enviro-Acoustic Research cc was commissioned to compile a Noise Compliance Statement as part of the Environmental Authorisation for the Karusa Battery Energy Storage System (BESS) and associated infrastructure. This facility is located approximately 45 km south of Sutherland, Northern Cape Province. The Terms of Reference for this study is the guideline set by SANS 10103:2008 and procedures promulgated in GG 43110 of 20 March 2020.

### **BRIEF PROJECT DESCRIPTION**

Enel Green Power South Africa (Pty) Ltd proposes the construction and operation of a Battery Energy Storage System (BESS) and associated grid infrastructure ~45km south of the town of Sutherland along the R354 and 47km north west of the town of Laingsburg along the R323 in the Northern Cape Province. The project will be located on Farm De Hoop 202 within the Karoo Hoogland Local Municipality which lies within the jurisdiction of the Namakwa District Municipality. The BESS will store and supply dispatchable energy as and when required by the off-taker.

The proposed project will include the following infrastructure:

- » A BESS with a capacity of up to 2 000 MWh, inside containers with a footprint of up to 6ha in extent and a maximum height of 3m. Both lithium-ion and Redox-flow technology are being considered for the project, depending on which is most feasible at the time of implementation.
- » Access roads to the BESS (10m in width, approximately 70m long) branching off of the existing roads, and internal roads (up to 8m wide) to be located within the total BESS footprint area.
- » 33kV MV cabling between the BESS and the MV/HV substation and up to 132kV HV cabling to the HV substation
- » Fencing around the BESS for increased security measures.
- » Up to 132kV overhead or underground power line to be connected to the existing Hidden Valley Substation.
- » Temporary laydown area to be located within the BESS footprint.
- » Firebreak to be located within the BESS footprint.
- » A Substation with a maximum height of - HV bus-bar up to 10 m max and an HV Building up to 4 m max

The general purpose and utilisation of a BESS is to save and store electricity from the network, allowing for a timed release of electricity to the grid when the capacity is required. BESS

systems therefore provide flexibility in the efficient operation of the electricity grid through decoupling of the energy supply and demand.

The following is being considered within the Basic Assessment process for this project:

- » Buffer around the BESS site of 200m
- » Power line corridor (100m) with 50m either side of centre line
- » Buffer around Hidden Valley Substation of 200m

### **EXISTING AMBIENT SOUND LEVELS**

Ambient sound levels were measured at a number of locations in the area in the last decade using class-1 Sound Level Meters. The sound level meters would measure “average” sound levels over a 10 minutes period, save the data and start with a new 10-minute measurement till the instrument was stopped.

The area has a rural character in terms of appearance and development, with a high potential to be quiet at times. Ambient sound levels were elevated at times, mainly due to wind-induced noises (natural), birds and insects (natural). Most farmers will consider this to be naturally quiet.

As most of the area were considered naturally quiet, it was selected to assign an acceptable noise rating level of a rural noise district (as per SANS 10103:2008). Typical night-time sound levels will be less than 35 dBA with daytime sound levels being less than 45 dBA (no, or low wind conditions).

### **CLOSEST POTENTIAL NOISE-SENSITIVE RECEPTORS**

Residential areas and potential noise-sensitive developments/receptors were identified using tools such as Google Earth® as well as the potential sensitive areas (using the online Screening Tool. The status of the receptors was confirmed and defined during the site visit in November 2011 when ambient sound levels were measured in the vicinity of the Karusa WEF.

The closest identified receptor is located further than 1.7 km from the proposed BESS. At this distance sounds from the BESS will be inaudible.

### **FINDINGS, SUMMARY AND RECOMMENDATION**

The BESS facility generates low levels of noise relating to the climate control system, with an audible hum associated with transformers. Considering the potential infrastructure, the proposed infrastructure would be further than 1,000 m from the closest identified NSD.

At an estimated noise level of less than 60 dB (at 10 m), this is an insignificant noise and this noise will be inaudible at a distance further than 500 m from such a BESS. Noises from

transformers are generally less than 85 dBA (measured at 2 m), and the transformers will be inaudible at 500 m. The noises will be inaudible at the closest NSD.

It is therefore the opinion of the author that there exists no potential for a noise impact and that no further Scoping or other acoustical studies would be required for the proposed BESS and associated infrastructure. No specific mitigation measures regarding noise or additional noise measurements are recommended. No additional conditions regarding noise are recommended for inclusion in the EMPr.

**This report should be sited as:**

De Jager, M. (2022): "Noise Compliance Statement and Screening Noise Report for the Proposed Karusa Battery Energy Storage System and Associated Infrastructure located in the Northern Cape Province". Enviro-Acoustic Research cc, Pretoria

**Client:**

Savannah Environmental (Pty) Ltd for  
Enel Green Power South Africa (Pty) Ltd

PO BOX 148  
Sunninghill  
Gauteng  
2157

**Report no:**

SE-BESSKWF/NCS/20220323-Rev 0

**Author:**

M. de Jager (B. Ing (Chem))

**Review:**

Johan Maré (M. Sc., Pr.Sci.Nat)

**Date:**

March 2022

**COPYRIGHT WARNING**

This information is privileged and confidential in nature and unauthorized dissemination or copying is prohibited. This information will be updated as required. Enel Green Power South Africa (Pty) Ltd claims protection of this information in terms of the Promotion of Access to Information Act, (No 2 of 2002) and without limiting this claim, especially the protection afforded by Chapter 4.

The document is the property of Enviro Acoustic Research CC. The content, including format, manner of presentation, ideas, technical procedure, technique and any attached appendices are subject to copyright in terms of the Copyright Act 98 of 1978 (as amended by the respective Copyright Amendment Acts No. 56 of 1980, No. 66 of 1983, No. 52 of 1984, No. 39 of 1986, No. 13 of 1988, No. 61 of 1989, No. 125 of 1992, Intellectual Property Laws Amendment Act, No. 38 of 1997 and, No. 9 of 2002) in terms of section 6 of the aforesaid Act, and may only be reproduced as part of the Environmental Authorization process by Savannah Environmental (Pty) Ltd.

## TABLE OF CONTENTS

	page
<b>EXECUTIVE SUMMARY .....</b>	<b>ii</b>
<b>TABLE OF CONTENTS.....</b>	<b>vi</b>
<b>LIST OF TABLES .....</b>	<b>vii</b>
<b>LIST OF FIGURES .....</b>	<b>vii</b>
<b>APPENDICES .....</b>	<b>vii</b>
<b>GLOSSARY OF ABBREVIATIONS .....</b>	<b>viii</b>
<b>1 THE AUTHOR .....</b>	<b>1</b>
<b>2 DECLARATION OF INDEPENDENCE .....</b>	<b>4</b>
<b>3 CHECKLIST: GG43110 MINIMUM REQUIREMENTS .....</b>	<b>5</b>
<b>4 INTRODUCTION.....</b>	<b>6</b>
4.1 Introduction and Purpose .....	6
4.2 Brief Project Description .....	6
4.3 Potential Noise Sources .....	7
4.3.1 Noise from BESS.....	7
4.3.2 Transformer noises (Substations).....	8
4.3.3 Transmission Line Noise (Corona noise).....	9
4.4 Project Location .....	9
4.4.1 Topography.....	10
4.4.2 Surrounding Land Use.....	10
4.4.3 Roads and Railway Lines .....	10
4.4.4 Existing Ambient Sound Levels.....	10
4.4.5 Potential Sensitive Receptors (Noise-Sensitive Developments).....	10
4.4.6 Other industrial and commercial processes .....	11
4.5 Terms of Reference .....	11
<b>5 LEGAL CONTEXT, POLICIES AND GUIDELINES.....</b>	<b>15</b>
5.1 The Republic of South Africa Constitution Act ("the Constitution") ..	15
5.2 The National Environmental Management Act (Act 107 of 1998).....	15
5.3 The Environment Conservation Act (Act 73 of 1989).....	16
5.3.1 National Noise Control Regulations (GN R154 of 1992) .....	16

5.4 Noise Standards ..... 17

5.5 International Guidelines ..... 18

    5.5.1 Night Noise Guidelines for Europe (WHO, 2009)..... 18

    5.5.2 Guidelines for Community Noise (WHO, 1999)..... 19

    5.5.3 IFC: General EHS Guidelines – Environmental Noise Management ..... 19

**6 ASSUMPTIONS AND LIMITATIONS ..... 20**

    6.1 Ambient Sound Levels..... 20

    6.2 Adequacy of Underlying Assumptions ..... 21

    6.3 Uncertainties of Information Provided..... 22

**7 METHODOLOGY: SCREENING QUESTIONNAIRE ..... 23**

**8 CONCLUSIONS AND RECOMMENDATIONS ..... 25**

**9 REFERENCES..... 26**

**LIST OF TABLES**

	page
Table 5-1: IFC Table .7.1-Noise Level Guidelines.....	19
Table 7-1: Questions for Noise Screening (SANS 10328:2008).....	23

**LIST OF FIGURES**

	page
Figure 4-1: Conceptual BESS components	8
Figure 4-2: Locations of proposed BESS in relation to the identified noise-sensitive developments (receptors)	13
Figure 4-3: Output from the Environmental Screening Tool - BESS is located in an area with low noise sensitivity	14

**APPENDICES**

[Appendix A](#) Glossary of Acoustic Terms, Definitions and General Information

## **GLOSSARY OF ABBREVIATIONS**

AZSL	Acceptable Zone Sound Level (Rating Level)
dB	Decibel
DACE	Department of Agriculture, Conservation and Environment
DEAT	Department of Environmental Affairs and Tourism
EARES	Enviro-Acoustic Research cc
ECA	Environment Conservation Act, 1989 (Act No 78 of 1989)
EIA	Environmental Impact Assessment
ENIA	Environmental Noise Impact Assessment
ENPAT	Environmental Potential Atlas
EP	Equator Principle
EPFI	Equator Principle Financial Institutions
Etc.	etcetera / and so forth
f	fast setting, see <a href="#">Appendix A</a>
GG	Government Gazette
GNR	Government Notice Regulation
Hz	Hertz
i	Impulse setting, see <a href="#">Appendix A</a>
I&AP(s)	Interested and Affected Party(ies)
i.e.	that is
IFC	International Finance Corporation
In/sec	inches per second
Kg/m <sup>2</sup>	kilogram per square metres
km/h	kilometres per hour
LA10	See <a href="#">Appendix A</a>
LA90	See <a href="#">Appendix A</a>
LAeq	See <a href="#">Appendix A</a>
LAm <sub>ax</sub>	See <a href="#">Appendix A</a>
LAm <sub>in</sub>	See <a href="#">Appendix A</a>
m	Metres
m/s	Metres per second
m <sup>2</sup>	Square metre
m <sup>3</sup>	Cubic metre
mamsl	Metre above mean sea level
mm	millimetre
NCR	Noise Control Regulations (under Section 25 of the ECA)
NEMA	National Environmental Management Act, 1998 (Act No 107 of 1998)



NGO	Non-government Organisation
NR	Noise Reduction
NSD	Noise-Sensitive Development
p/d	per day
PPE	Personal Protective Equipment
PPP	Public Participation Process
Rpm	Revolutions per minute
RSA	Republic of South Africa
SABS	South African Bureau of Standards
SANS	South African National Standards
t	Time
TOR	Terms of Reference
WHO	World Health Organisation

## 1 THE AUTHOR

The Author, Morné de Jager, started his career in the mining industry as a bursar Learner Official (JCI, Randfontein), working in the mining industry, doing various mining related courses (Rock Mechanics, Surveying, Sampling, Safety and Health [Ventilation, noise, illumination etc] and Metallurgy. He did work in both underground (Coal, Gold and Platinum) as well as opencast (Coal) for 4 years. He changed course from Mining Engineering to Chemical Engineering after his second year of his studies at the University of Pretoria.

After graduation he worked as a Water Pollution Control Officer at the Department of Water Affairs and Forestry for two years (first year seconded from Wates, Meiring and Barnard), where duties included the perusal (evaluation, commenting and recommendation) of various regulatory required documents (such as EMPR's, Water Licence Applications and EIA's), auditing of licence conditions as well as the compilation of Technical Documents.

Since leaving the Department of Water Affairs, Morné has been in private consulting for the last 20 years, managing various projects for the mining and industrial sector, private developers, business, other environmental consulting firms as well as the Department of Water Affairs. During that period he has been involved in various projects, either as specialist, consultant, trainer or project manager, successfully completing these projects within budget and timeframe. During that period he gradually moved towards environmental acoustics, focusing on this field exclusively since 2007.

He has been interested in acoustics as from school days, doing projects mainly related to loudspeaker design. Interest in the matter brought him into the field of Environmental Noise Measurement, Prediction and Control. He has been doing work in this field for the past 13 years, and was involved with the following projects in the last few years:

### Wind Energy Facilities

*Full Environmental Noise Impact Assessments for - Bannf (Vidigenix), iNca Gouda (Aurecon SA), Kangnas (Aurecon), Plateau East and West (Aurecon), Wolf (Aurecon), Outeniqwa (Aurecon), Umsinde Emoyeni (ARCUS) , Komsberg (ARCUS), Karee and Kolkies Wind Farms (ARCUS), Canyon Springs (Canyon Springs), Perdekraal (ERM), Zen (Savannah Environmental – SE), Goereesoe (SE), Springfontein (SE), Garob (SE), Project Blue (SE), ESKOM Kleinzee (SE), Walker Bay (SE), Oyster Bay (SE), Hidden Valley (SE), Happy Valley (SE), Deep River (SE), Tsitsikamma (SE), AB (SE), West Coast One (SE), Hopefield II (SE), Namakwa Sands (SE), VentuSA Gouda (SE), Dorper (SE), Amakhala Emoyeni (SE), Klipheuwel (SE), Cookhouse (SE), Cookhouse II (SE), Rhebokfontein (SE), Suurplaat (SE), Karoo Renewables (SE), Koningaas (SE), Eskom Aberdene (SE), Spitskop (SE), Castle (SE), Khai Ma (SE), Poortjies (SE), Korana (SE), IE Moorreesburg (SE), Gunstfontein (SE), Vredenburg (Terramanzi), Loeriesfontein (SiVEST), Rhenosterberg (SiVEST), Noupoot (SiVEST), Prieska (SiVEST), Dwarsrug (SiVEST), Msenge Emoyeni (Windlab), Isivunguvungu Wind Farm (Aurecon), Graskoppies (SiVEST), Hartebeest Leegte (SiVEST), Ithemba (SiVEST), !Xha Boom (SiVEST), Kokerboom 1 (Aurecon), Kokerboom 2 (Aurecon), Teekloof (Mainstream), Sutherland (CSIR), Rietrug (CSIR), Sutherland 2 (CSIR), Spitskop West (Terramanzi)*

<p><b>Mining and Industry</b></p>	<p>Full Environmental Noise Impact Assessments for – Delft Sand (AGES), BECSA – Middelburg (Golder Associates), Kromkrans Colliery (Geovicon Environmental), SASOL Borrow Pits Project (JMA Consulting), Lesego Platinum (AGES), Tweefontein Colliery (Cleanstream Environmental), Evraz Vametco Mine and Plant (JMA), Goedehoop Colliery (Geovicon), Hacra Project (Prescali Environmental), Der Brochen Platinum Project (J9 Environment), Brandbach Sand (AGES), Verkeerdepan Extension (CleanStream Environmental), Dwaalboom Limestone (AGES), Jagdlust Chrome (MENCO), WPB Coal (MENCO), Landau Expansion (CleanStream Environmental), Otjikoto Gold (AurexGold), Klipfontein Colliery (MENCO), Imbabala Coal (MENCO), ATCOM East Expansion (Jones and Wagner), IPP Waterberg Power Station (SE), Kangra Coal (ERM), Schoongesicht (CleanStream Environmental), EastPlats (CleanStream Environmental), Chapudi Coal (Jacana Environmental), Generaal Coal (JE), Mopane Coal (JE), Glencore Boshhoek Chrome (JMA), Langpan Chrome (PE), Vlakpoort Chrome (PE), Sekoko Coal (SE), Frankford Power (REMIG), Strahrae Coal (Ferret Mining), Transalloys Power Station (Savannah), Pan Palladum Smelter, Iron and PGM Complex (Prescali Environmental), Fumani Gold (AGES), Leiden Coal (EIMS), Colenso Coal and Power Station (SiVEST/EcoPartners), Klippoortjie Coal (Gudani), Rietspruit Crushers (MENCO), Assen Iron (Tshikovha), Transalloys (SE), ESKOM Ankerlig (SE), Pofadder CSP (SE), Nooitgedacht Titano Project (EcoPartners), Algoa Oil Well (EIMS), Spitskop Chrome (EMAssistance), Vlakfontein South (Gudani), Leandra Coal (Jacana), Grazvalley and Zoetveld (Prescali), Tjate Chrome (Prescali), Langpan Chromite (Prescali), Vereeniging Recycling (Pro Roof), Meyerton Recycling (Pro Roof), Hammanskraal Billeting Plant 1 and 2 (Unica), Development of Altona Furnace, Limpopo Province (Prescali Environmental), Haakdoorndrift Opencast at Amandelbult Platinum (Aurecon), Landau Dragline relocation (Aurecon), Stuart Coal Opencast (CleanStream Environmental), Tetra4 Gas Field Development (EIMS), Kao Diamonds – Tiping Village Relocation (EIMS), Kao Diamonds – West Valley Tailings Deposit (EIMS), Upington Special Economic Zone (EOH), Arcelor Mittal CCGT Project near Saldanha (ERM), Malawi Sugar Mill Project (ERM), Proposed Mooifontein Colliery (Geovicon Environmental), Goedehoop North Residue Deposit Expansion (Geovicon Environmental), Mutsho 600MW Coal-Fired Power Plant (Jacana Environmental), Tshivhaso Coal-Fired Power Plant (Savannah Environmental), Doornhoek Fluorspar Project (Exigo)</p>
<p><b>Road and Railway</b></p>	<p>K220 Road Extension (UrbanSmart), Boskop Road (MTO), Sekoko Mining (AGES), Davel-Swaziland-Richards Bay Rail Link (Aurecon), Moloto Transport Corridor Status Quo Report and Pre-Feasibility (SiVEST), Postmasburg Housing Development (SE), Tshwane Rapid Transport Project, Phase 1 and 2 (NRM Consulting/City of Tshwane), Transnet Apies-river Bridge Upgrade (Transnet), Gautrain Due-diligence (SiVest), N2 Piet Retief (SANRAL), Atterbury Extension, CoT (Bokomoso Environmental)</p>
<p><b>Airport</b></p>	<p>Oudtshoorn Noise Monitoring (AGES), Sandton Heliport (Alpine Aviation), Tete Airport Scoping (Aurecon)</p>
<p><b>Noise monitoring and Audit Reports</b></p>	<p>Peerboom Colliery (EcoPartners), Thabametsi (Digby Wells), Doxa Deo (Doxa Deo), Harties Dredging (Rand Water), Xstrata Coal – Witbank Regional (Xstrata), Sephaku Delmas (AGES), Amakhala Emoyeni WEF (Windlab Developments), Oyster Bay WEF (Renewable Energy Systems), Tsitsikamma WEF Ambient Sound Level study (Cennergi and SE), Hopefield WEF (Umoya), Wesley WEF (Innowind), Ncora WEF (Innowind), Boschmanspoort (Jones and Wagner), Nqamakwe WEF (Innowind), Hopefield WEF Noise Analysis (Umoya), Dassiesfontein WEF Noise Analysis (BioTherm), Transnet Noise Analysis (Aurecon), Jeffries Bay Wind Farm (Globeleg), Sephaku Aganang (Exigo), Sephaku Delmas (Exigo), Beira Audit (BP/GPT), Nacala Audit (BP/GPT), NATREF (Nemai), Rappa Resources (Rayten), Measurement Report for Sephaku Delmas (Ages), Measurement Report for Sephaku Aganang (Ages), Development noise measurement protocol for Mamba Cement (Exigo), Measurement Report for Mamba Cement (Exigo), Measurement Report for Nokeng Fluorspar (Exigo), Tsitsikamma Community Wind Farm Pre-operation sound measurements (Cennergi), Waainek WEF Operational Noise Measurements (Innowind), Sedibeng Brewery Noise Measurements (MENCO), Tsitsikamma Community Wind Farm Operational noise measurements (Cennergi), Noupoot Wind Farm Operational noise measurements (Mainstream),</p>
<p><b>Small Noise Impact Assessments</b></p>	<p>TCTA AMD Project Baseline (AECOM), NATREF (Nemai Consulting), Christian Life Church (UrbanSmart), Kosmosdale (UrbanSmart), Louwlandia K220 (UrbanSmart), Richards Bay Port Expansion (AECOM), Babalegi Steel Recycling (AGES), Safika Slag Milling Plant (AGES), Arcelor Mittal WEF (Aurecon), RVM Hydroplant (Aurecon), Grootvlei PS Oil Storage (SiVEST),</p>

**Project reviews and amendment reports**

*Rhenosterberg WEF, (SiVEST), Concerto Estate (BPTrust), Ekuseni Youth Centre (MENCO), Kranskop Industrial Park (Cape South Developments), Pretoria Central Mosque (Noman Shaikh), Soshanguve Development (Maluleke Investments), Seshego-D Waste Disposal (Enviroexcellence), Zambesi Safari Equipment (Owner), Noise Annoyance Assessment due to the Operation of the Gautrain (Thornhill and Lakeside Residential Estate), Upington Solar (SE), Ilangaletu Solar (SE), Pofadder Solar (SE), Flagging Trees WEF (SE), Uyekraal WEF (SE), Ruuki Power Station (SE), Richards Bay Port Expansion 2 (AECOM), Babalegi Steel Recycling (AGES), Safika Ladium (AGES), Safika Cement Isando (AGES), RareCo (SE), Struisbaai WEF (SE), Perdekraal WEF (ERM), Kotula Tsatsi Energy (SE), Olievenhoutbosch Township (Nali), , HDMS Project (AECOM), Quarry extensions near Ermelo (Rietspruit Crushers), Proposed uMzimkhulu Landfill in KZN (nZingwe Consultancy), Linksfield Residential Development (Bokomoso Environmental), Rooihuiskraal Ext. Residential Development, CoT (Plandev Town Planners), Floating Power Plant and LNG Import Facility, Richards Bay (ERM), Floating Power Plant project, Saldanha (ERM), Vopak Growth 4 project (ERM), Elandsport Ext 3 Residential Development (Gibb Engineering)*

*Loperberg (Savannah), Dorper (Savannah), Penhoek Pass (Savannah), Oyster Bay (RES), Tsitsikamma Community Wind Farm Noise Simulation project (Cennerg), Amakhala Emoyeni (Windlab), Spreeukloof (Savannah), Spinning Head (SE), Kangra Coal (ERM), West Coast One (Moyeng Energy), Rhebokfontein (Moyeng Energy), De Aar WEF (Holland), Quarterly Measurement Reports – Dangote Delmas (Exigo), Quarterly Measurement Reports – Dangote Lichtenburg (Exigo), Quarterly Measurement Reports – Mamba Cement (Exigo), Quarterly Measurement Reports – Dangote Delmas (Exigo) Quarterly Measurement Reports – Nokeng Exigo, Proton Energy Limited Nigeria (ERM), Hartebeest WEF Update (Moorreesburg) (Savannah Environmental), Modderfontein WEF Opinion (Terramanzi), IPD Vredenburg WEF (IPD Power Vredenburg)*

**Contact details for the Author are:**

Author: Morné de Jager  
 Company: Enviro-Acoustic Research cc  
 Website: <http://www.eares.co.za>  
 Email: [morne@eares.co.za](mailto:morne@eares.co.za)  
 Office number: 012 004 0362  
 Mobile number: 082 565 4059

## 2 DECLARATION OF INDEPENDENCE

I, Morné de Jager declare that:

- I act as the specialist in this application;
- I will perform the work relating to the application in an objective manner, even if this results in views and findings that are not favourable to the applicant;
- I declare that there are no circumstances that may compromise my objectivity in performing such work;
- I have expertise in conducting noise measurement reports, environmental noise impact assessments, including knowledge of the National Environmental Management Act (107 of 1998), the Environmental Impact Assessment Regulations of 2010, and any regulations and guidelines that have relevance to the proposed activity or work;
- I will comply with the Act, regulations and all other applicable legislation;
- I will take into account, to the extent possible, the matters listed in regulation 8 of the regulations when preparing the application and any report relating to the application;
- I have no, and will not engage in, conflicting interests in the undertaking of the activity;
- I undertake to disclose to the applicant and the competent authority all material information in my possession that reasonably has or may have the potential of influencing - any decision to be taken with respect to the project or application by the competent authority; and - the objectivity of any report, plan or document to be prepared by myself for submission to the competent authority;
- I will ensure that the comments of all interested and affected parties are considered and recorded in reports that are submitted to the competent authority in respect of the application, provided that comments that are made by interested and affected parties in respect of a final report that will be submitted to the competent authority may be attached to the report without further amendment to the report;
- I will provide the competent authority with access to all information at my disposal regarding the project or application, whether such information is favourable to the applicant or not
- all the particulars furnished by me in this report are true and correct;
- will perform all other obligations as expected from an environmental assessment practitioner in terms of the Regulations; and
- I realise that a false declaration is an offence in terms of regulation 71 and is punishable in terms of section 24F of the Act.

**Disclosure of Vested Interest**

I do not have and will not have any vested interest (either business, financial, personal or other) in the proposed activity proceeding other than remuneration for work performed.

  
Signature of the environmental practitioner:

**Enviro-Acoustic Research cc**  
Name of company:

**2022 / 03 / 23**  
Date:

**3 CHECKLIST: GG43110 MINIMUM REQUIREMENTS**

The Noise Compliance Statement must contain, as a minimum, the following information:

<b>Requirement</b>	<b>Comment / Reference</b>
Contact details of the environmental assessment practitioner or noise specialist, their relevant qualifications and expertise in preparing the statement, and a curriculum vitae	See section 1
a signed statement of independence by the environmental assessment practitioner or noise specialist.	See section 2 and Separate Document
a map showing the proposed development footprint (including supporting infrastructure) overlaid on the noise sensitivity map generated by the screening tool	Figure 4-3
confirmation that all reasonable measures have been taken through micro- siting to minimize disturbance to receptors	Not required as potential noise impact is low at the location where the Battery Energy Storage System is proposed.
a substantiated statement from the environmental assessment practitioner or noise specialist on the acceptability, or not, of the proposed development and a recommendation on the approval, or not, of the proposed development	See section 8
any conditions to which this statement is subjected	See section 8
where required, proposed impact management outcomes or any monitoring requirements for inclusion in the EMPr	See section 8
a description of the assumptions made and any uncertainties or gaps in knowledge or data as well as a statement of the timing and intensity of site inspection observations	See section 6

## 4 INTRODUCTION

### 4.1 INTRODUCTION AND PURPOSE

Enviro-Acoustic Research cc was commissioned to compile a Noise Compliance Statement as part of the Environmental Authorisation for the Karusa Battery Energy Storage System (BESS) and associated infrastructure. This facility is located approximately 45 km south of Sutherland, Northern Cape Province.

Proponents intending to submit an application for environmental authorisation must screen their proposed site for any environmental sensitivity. The Screening Tool also provides site specific EIA process and review information, identifies related exclusions and/or specific requirements including specialist studies applicable to the proposed site and/or development. The Screening Tool considers the national sector classification and the environmental sensitivity of the site.

Finally, the Screening Tool allows for the generating of a Screening Report (required to accompany any application for Environmental Authorisation) this also highlight the required specialist studies to be appended to the application for environmental authorization. While noise is not defined as an environmental theme that needs further investigation, Enel Green Power South Africa (Pty) Ltd selected to investigate the risk of noise from this facility.

This report therefore considers the requirements of SANS 10328:2008 as well as GNR 320 of 2020 (GG4311 of March 2020). This guideline allows the assessment of noise impacts on the environment due to a proposed activity that might impact on the environment using an administrative screening questionnaire. If the outcome of all the questions is negative, the planned development or activity is not likely to present a noise disturbance and a Screening report may be submitted to the relevant authorities as part of the Environmental Authorization process.

### 4.2 BRIEF PROJECT DESCRIPTION

Enel Green Power South Africa (Pty) Ltd proposes the construction and operation of a Battery Energy Storage System (BESS) and associated grid infrastructure ~45km south of the town of Sutherland along the R354 and 47km north west of the town of Laingsburg along the R323 in the Northern Cape Province. The project will be located on Farm De Hoop 202 within the Karoo Hoogland Local Municipality which lies within the jurisdiction of the Namakwa District Municipality. The BESS will store and supply dispatchable energy as and when required by the off-taker.

The proposed project will include the following infrastructure:

- A BESS with a capacity of up to 2 000 MWh, inside containers with a footprint of up to 6ha in extent and a maximum height of 3m. Both lithium-ion and Redox-flow technology are being considered for the project, depending on which is most feasible at the time of implementation.
- Access roads to the BESS (10m in width, approximately 70m long) branching off of the existing roads, and internal roads (up to 8m wide) to be located within the total BESS footprint area.
- 33kV MV cabling between the BESS and the MV/HV substation and up to 132kV HV cabling to the HV substation
- Fencing around the BESS for increased security measures.
- Up to 132kV overhead or underground power line to be connected to the existing Hidden Valley Substation.
- Temporary laydown area to be located within the BESS footprint.
- Firebreak to be located within the BESS footprint.
- A Substation with a maximum height of - HV bus-bar up to 10 m max and an HV Building up to 4 m max

The general purpose and utilisation of a BESS is to save and store electricity from the network, allowing for a timed release of electricity to the grid when the capacity is required. BESS systems therefore provide flexibility in the efficient operation of the electricity grid through decoupling of the energy supply and demand.

The following is being considered within the Basic Assessment process for this project:

- Buffer around the BESS site of 200m
- Power line corridor (100m) with 50m either side of centre line
- Buffer around Hidden Valley Substation of 200m

## **4.3 POTENTIAL NOISE SOURCES**

### **4.3.1 Noise from BESS**

The typical components of a BESS are (source: ADB, 2018):

- The battery system which could consist of:
  - Multiple cells,
  - The battery management system; and,
  - The battery thermal management system.
- Components required for the reliable operation of the overall system, including:
  - Energy management system; and,
  - System thermal management.



- Power electronics that can be grouped into the conversion unit (such as an inverter), which manage the power flow between the grid and battery, including the required control and monitoring components, voltage sensing units and thermal management of power electronic components (fans or climate control system).

There could be numerous such BESSs running in parallel to increase the total storage capacity of the system up to the desired or needed capacity. The typical components are illustrated in **Figure 4-1**.

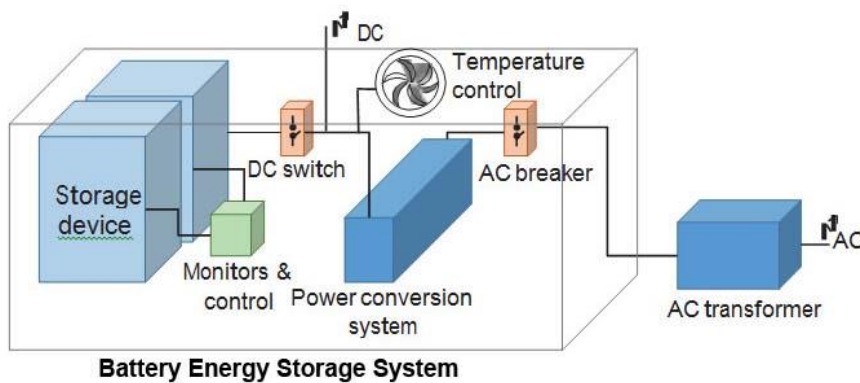

**Figure 4-1: Conceptual BESS components**

While certain components may generate a slight hum under load, the dominant source of noise is from the fans or climate control system used to manage heat in the system and/or to maintain the BESS within its optimal operating temperature range. Manufacturers of such equipment indicate low noise levels at source when the BESS gets to a certain temperature and require cooling or heating, with noises (at 10 m) being less than 60 dBA. This is a low sound level and will result in the noise being inaudible at distances further than 500 m in a quiet environment.

**4.3.2 Transformer noises (Substations)**

Also known as magnetostriction, is when the sheet steel used in the core of the transformer tries to change shape when being magnetised. When the magnetism is taken away, the shape returns, only to try and deform in a different manner when the polarity is changed.

This deformation is not uniform; consequently it varies all over a sheet. With a transformer core being composed of many sheets of steel, these deformations are taking place erratically all over each sheet, and each sheet is behaving erratically with respect to its neighbour. The resultant is the “hum” frequently associated with transformers. While this may be a soothing sound in small home appliances, various complaints are logged in areas where people stay close to these transformers. At a voltage frequency of 50 Hz, these “vibrations” take place 100 times a second, resulting in a tonal noise at 100Hz.

***However, this is a relatively easy noise to mitigate with the use of acoustic shielding (when located in residential areas) and/or placement of the transformer. Substations in addition generate low noise levels, with the hum from the transformers inaudible further than 500 m from the substations.***

#### **4.3.3 Transmission Line Noise (Corona noise)**

Corona noise is caused by the partial breakdown of the insulation properties of air surrounding the conducting wires. It can generate an audible and radio-frequency noise, but generally only occurs in humid conditions, as provided by fog or rain. A minimum line potential of 70kV or higher is generally required to generate corona noise depending on the electrical design. Corona noise does not occur on domestic distribution lines.

Corona noise has two major components: a low frequency tone associated with the frequency of the AC supply (100 Hz for 50 Hz source) and a broadband noise. The tonal component of the noise is related to the point along the electric waveform at which the air begins to conduct. This varies with each cycle and consequently the frequency of the emitted tone is subject to great fluctuations. Corona noise can be characterised as broadband 'crackling' or 'buzzing', but ***fortunately it is generally only a feature that occurs during fog or rain.***

It will not be further investigated, as corona discharges results in:

- Power losses,
- Audible noises,
- Electromagnetic interference,
- A purple glow,
- Ozone production; and
- Insulation damage.

***As such Electrical Service Providers, such as ESKOM, go to great lengths to design power transmission equipment to minimise the formation of corona discharges. In addition, it is an infrequent occurrence with a relatively short duration.***

#### **4.4 PROJECT LOCATION**

The proposed BESS may be developed around 1,400 m to the south-east of the Hidden Valley substation as indicated in **Figure 4-2** and **Figure 4-3**. The study area is also further described in terms of environmental components that may contribute or change the sound character in the area.

#### 4.4.1 Topography

ENPAT<sup>1</sup> (1998) describes the topography as “*Low Mountains*”. Due to the micro nature of the study area, there are little natural features that could act as noise barrier considering practical distances at which sound propagates.

#### 4.4.2 Surrounding Land Use

Based on observations made during the site visit, the surrounding land use in the vicinity of the proposed development are agricultural (game and livestock) and wilderness (undeveloped and tourism).

#### 4.4.3 Roads and Railway Lines

There are no major roads or rail roads in the vicinity of the proposed project. Access to the BESS site will be through the use of existing access roads that will branch off to the BESS.

#### 4.4.4 Existing Ambient Sound Levels

Ambient sound levels were measured at a number of locations in the area in the last decade using class-1 Sound Level Meters. The sound level meters would measure “average” sound levels over a 10 minutes period, save the data and start with a new 10-minute measurement till the instrument was stopped.

The area has a rural character in terms of appearance and development, with a high potential to be quiet at times. Ambient sound levels were elevated at times, mainly due to wind-induced noises (natural), birds and insects (natural). Most farmers will consider this to be naturally quiet.

As most of the area were considered naturally quiet, it was selected to assign an acceptable noise rating level of a rural noise district (as per SANS 10103:2008). Typical night-time sound levels will be less than 35 dBA with daytime sound levels being less than 45 dBA (during no, or low wind conditions). Due to low anthropogenic-related development in the area, ambient sound levels measured in this area would still be similar in 2022 (see also Assumptions and Limitations, **section 6.1**).

#### 4.4.5 Potential Sensitive Receptors (Noise-Sensitive Developments)

Residential areas and potential noise-sensitive developments/receptors were identified using tools such as Google Earth<sup>®</sup> as well as the potential sensitive areas (using the Screening Tool, available at <https://screening.environment.gov.za/screeningtool/#/pages/welcome>). The closest potential noise-sensitive development (receptors) is highlighted in **Figure 4-2**. At a

---

<sup>1</sup> Van Riet, W. Claassen, P. van Rensburg, J. van Viegen & L. du Plessis, “*Environmental Potential Atlas for South Africa*”, Pretoria, 1998.

distance of 1.7 km the closest receptor is a significant distance from the closest location where the BESS may be developed.

#### 4.4.6 Other industrial and commercial processes

There are currently no other noise sources of significant importance in the area. There are a number of wind turbines proposed as part of the Hidden Valley Cluster of WEFs (Karusa, Great Karoo and Soetwater), with construction of these facilities underway. With the input data as used, a review of the Karusa WEF noise impact (18 September 2017) the above-mentioned assessment indicated that the proposed wind farm will have a noise impact of **low significance** on all potential noise-sensitive developments (NSDs) in the area during both the construction and operational phases.

#### 4.5 TERMS OF REFERENCE

SANS 10328:2008 (Edition 3) specifies the methodology to assess the noise impacts on the environment due to a proposed activity that might impact on the environment. The standard also stipulates the minimum requirements to be investigated for screening purposes. These minimum requirements are:

- a) Identification and description of the noise sources and noise-sensitive developments associated with the development that has to be investigated;
- b) Identification and description of the noise sources and noise-sensitive developments in the target area that could affect the development (or that could be affected by the development) that has to be investigated;
- c) Identification, with the assistance of all interested or affected parties, and description of all the noise sources and noise-sensitive developments associated with the development, or located within the target area, that are to be excluded from the investigation. The reason(s) for the exclusion shall be stated; and
- d) A reference to this standard regarding the method of investigation.

The purpose of the investigation is to determine, by administrative means, whether the proposed development could have any significant acoustical implications. It is based on an overview of all the information available as well as the review of a questionnaire. If the outcome of all the questions is negative, the planned development or activity is not likely to present a noise disturbance. In this case, a scoping investigation and an environmental noise impact investigation could be dispensed and this Screening report may be submitted to the relevant authorities as part of the Environmental Authorization process. If one or more of the answers to the questions for the Screening Report is affirmative, the acoustical impact could probably be significant and a scoping investigation and, if necessary, an environmental noise impact investigation shall be considered.

The Department of Environmental Affairs also promulgated Regulation 320, dated 20 March 2020 as published in Government Gazette No. 43110. The Procedures for the Assessment and Minimum Criteria for Reporting on Identified Environmental Themes in Terms of Sections 24(5)(a) and (h) and 44 of the National Environmental Management Act, 1998, when applying for Environmental Authorisation would be applicable to this project.

This regulation defines the requirements for undertaking a site sensitivity verification, specialist assessment and the minimum report content requirements for environmental impact where a specialist assessment is required but no protocol has been prescribed. It requires that the current land use be considered using the national web based environmental screening tool to confirm the site sensitivity available at: <https://screening.environment.gov.za>.

If an applicant intending to undertake an activity identified in the scope of this protocol for which a specialist assessment has been identified on the screening tool on a site identified as being of:

- "very high" sensitivity for noise, must submit a Noise Specialist Assessment; or
- "low" sensitivity for noise, must submit a Noise Compliance Statement.

On a site where the information gathered from the site sensitivity verification differs from the designation of "very high" sensitivity on the screening tool and it is found to be of a "low" sensitivity, a Noise Compliance Statement must be submitted. On a site where the information gathered from the initial site sensitivity verification differs from the designation of "low" sensitivity on the screening tool and it is found to be of a "very high" sensitivity, a Noise Specialist Assessment must be submitted.

If any part of the proposed development footprint falls within an area of "very high" sensitivity, the assessment and reporting requirements prescribed for the "very high" sensitivity apply to the entire footprint excluding linear activities for which noise impacts are associated with construction activities only and the noise levels return to the current levels after the completion of construction activities, in which case a compliance statement applies. In the context of this protocol, development footprint means the area on which the proposed development will take place and includes any area that will be disturbed.

The minimum requirements for a Noise Compliance Statement are also covered in **Section 3** in the form of a checklist. **Figure 4-3** illustrates the output defining the potential sensitivities around the proposed development, highlighting that proposed BESS would be located in an area with a low sensitivity to noise.

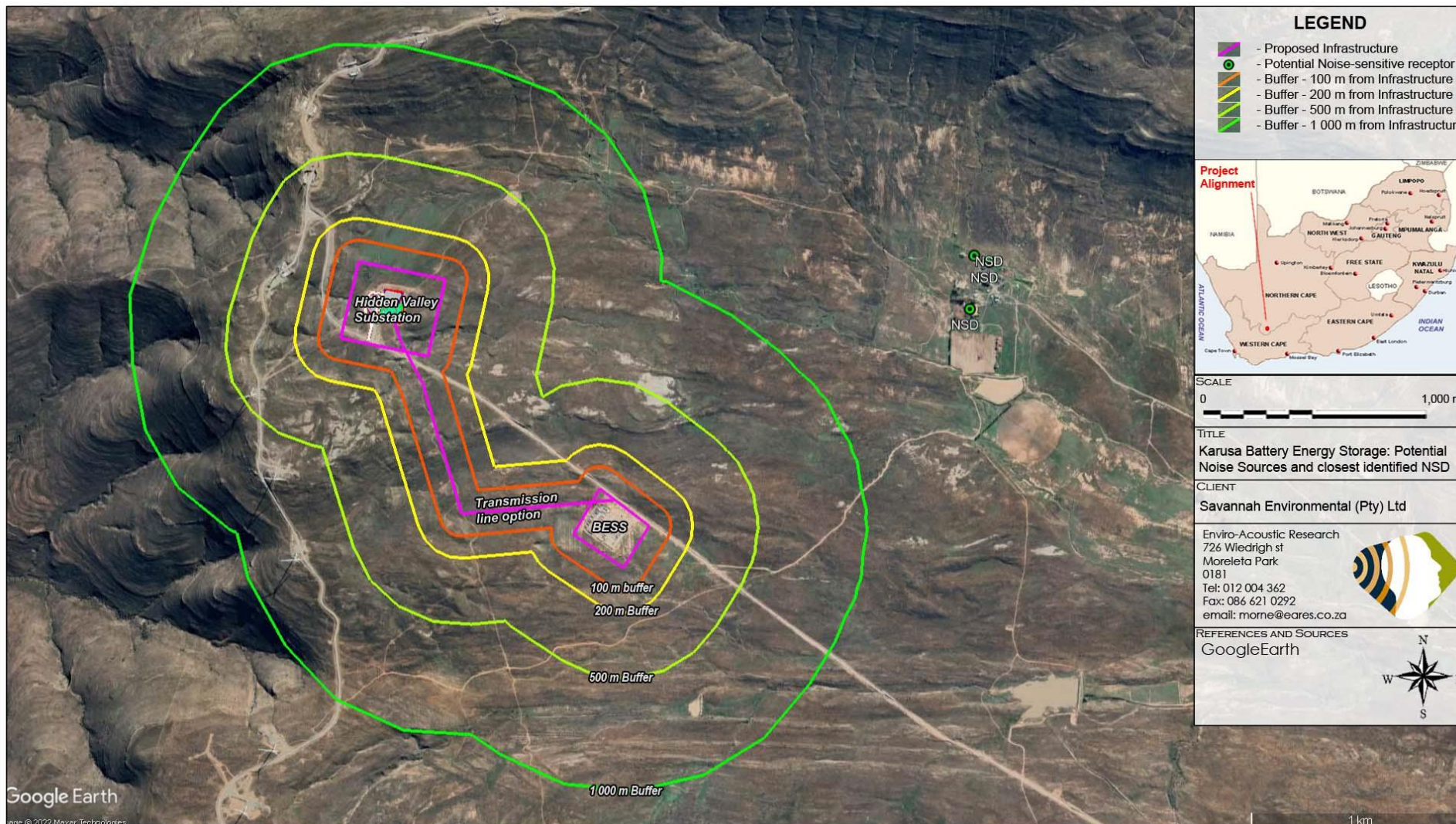

Figure 4-2: Locations of proposed BESS in relation to the identified noise-sensitive developments (receptors)

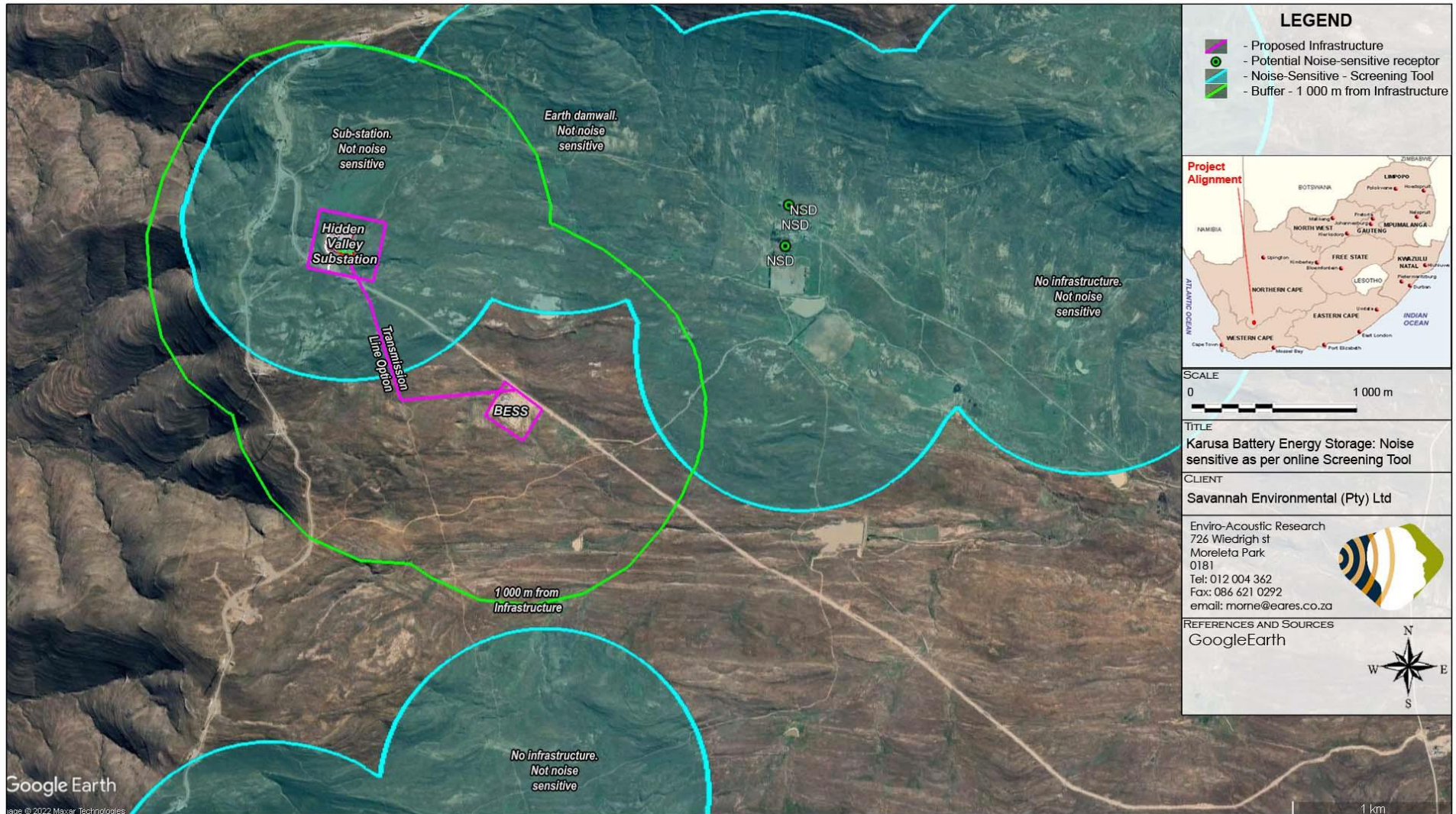

Figure 4-3: Output from the Environmental Screening Tool - BESS is located in an area with low noise sensitivity

## 5 LEGAL CONTEXT, POLICIES AND GUIDELINES

Legal policies, guidelines (National and International) are provided in this section for reference purpose.

### 5.1 THE REPUBLIC OF SOUTH AFRICA CONSTITUTION ACT (“THE CONSTITUTION”)

The environmental rights contained in section 24 of the Constitution provide that everyone is entitled to an environment that is not harmful to his or her well-being. In the context of noise, this requires a determination of what level of noise is harmful to well-being. The general approach of the common law is to define an acceptable level of noise as that which the reasonable person can be expected to tolerate in the particular circumstances. The subjectivity of this approach can be problematic which has led to the development of noise standards (see **Section 5.4**).

“Noise pollution” is specifically included in Part B of Schedule 5 of the Constitution, which means that noise pollution control is a local authority competence, provided that the local authority concerned has the capacity to carry out this function.

### 5.2 THE NATIONAL ENVIRONMENTAL MANAGEMENT ACT (ACT 107 OF 1998)

The National Environmental Management Act (“NEMA”) defines “pollution” to include any change in the environment, including noise. A duty therefore arises under section 28 of NEMA to take reasonable measures while establishing and operating any facility to prevent noise pollution occurring. NEMA sets out measures which may be regarded as reasonable. They include the following measures:

1. to investigate, assess and evaluate the impact on the environment;
2. to inform and educate employees about the environmental risks of their work and the manner in which their tasks must be performed in order to avoid causing significant pollution or degradation of the environment;
3. to cease, modify or control any act, activity or process causing the pollution or degradation;
4. to contain or prevent the movement of the pollution or degradation;
5. to eliminate any source of the pollution or degradation; and
6. to remedy the effects of the pollution or degradation.

In addition, a number of regulations have been promulgated as Regulation 982 of December 2014 (Government Notice 38282) in terms of this Act. It defines minimum information requirements for specialist reports, with Government Notice 43110 (20 March 2020) updating the minimum requirements for reporting.



### 5.3 THE ENVIRONMENT CONSERVATION ACT (ACT 73 OF 1989)

The Environment Conservation Act ("ECA") allows the Minister of Environmental Affairs and Tourism ("now the Ministry of Water and Environmental Affairs") to make regulations regarding noise, among other concerns. See also section 5.3.1. While most sections of this Act has been repealed with the promulgation of the NEMA, Section 25 of this Act is still in effect.

#### 5.3.1 National Noise Control Regulations (GN R154 of 1992)

The National Noise Control Regulations (GN R154 in *Government Gazette* No. 13717 dated 10 January 1992) were promulgated in terms of section 25 of the ECA. The NCRs were revised under Government Notice Number R. 55 of 14 January 1994 to make it obligatory for all authorities to apply the regulations.

Subsequently, in terms of Schedule 5 of the Constitution of South Africa of 1996 legislative responsibility for administering the noise control regulations was devolved to provincial and local authorities. The National Regulations will be in effect in the Northern Cape Province.

The National Noise Control Regulations (GN R154 1992) defines:

**"Controlled area"** as:

A piece of land designated by a local authority where, in the case of--

- c) Industrial noise in the vicinity of an industry-
  - i. the reading on an integrating impulse sound level meter, taken outdoors at the end of a period of 24 hours while such meter is in operation, exceeds 61 dBA; or
  - ii. the calculated outdoor equivalent continuous "A"-weighted sound pressure level at a height of at least 1,2 meters, but not more than 1,4 meters, above the ground for a period of 24 hours, exceeds 61 dBA;

**"disturbing noise"** as:

Noise level which exceeds the zone sound level or, if no zone sound level has been designated, a noise level which exceeds the ambient sound level at the same measuring point by 7 dBA or more.

**"zone sound level"** as:

A derived dBA value determined indirectly by means of a series of measurements, calculations or table readings and designated by a local authority for an area. *This is the same as the Rating Level as defined in SANS 10103:2008.*

**In addition:**

In terms of Regulation 2 -

"A local authority may –

*(c): if a noise emanating from a building, premises, vehicle, recreational vehicle or street is a disturbing noise or noise nuisance, or may in the opinion of the local authority concerned be a disturbing noise or noise nuisance, instruct in writing the person causing such noise or who is responsible therefor, or the owner or occupant of such building or premises from which or from where such noise emanates or may emanate, or all such persons, to discontinue or cause to be discontinued such noise, or to take steps to lower the level of the noise to a level conforming to the requirements of these Regulations within the period stipulated in the instruction: Provided that the provisions of this paragraph shall not apply in respect of a disturbing noise or noise nuisance caused by rail vehicles or aircraft which are not used as recreational vehicles;*

*(d): before changes are made to existing facilities or existing uses of land or buildings, or before new buildings are erected, in writing require that noise impact assessments or tests are conducted to the satisfaction of that local authority by the owner, developer, tenant or occupant of the facilities, land or buildings or that, for the purposes of regulation 3(b) or (c), reports or certificates in relation to the noise impact to the satisfaction of that local authority are submitted by the owner, developer, tenant or occupant to the local authority on written demand";*

In terms of Regulation 4 of the Noise Control Regulations:

*"No person shall make, produce or cause a disturbing noise, or allow it to be made, produced or caused by any person, machine, device or apparatus or any combination thereof".*

## **5.4 NOISE STANDARDS**

There are a few South African scientific standards (SABS) relevant to noise from developments, industry and roads. They are:

- SANS 10103:2008. 'The measurement and rating of environmental noise with respect to annoyance and to speech communication'.
- SANS 10210:2004. 'Calculating and predicting road traffic noise'.
- SANS 10328:2008. 'Methods for environmental noise impact assessments'.
- SANS 10357:2004. 'The calculation of sound propagation by the Concave method'.
- SANS 10181:2003. 'The Measurement of Noise Emitted by Road Vehicles when Stationary'.
- SANS 10205:2003. 'The Measurement of Noise Emitted by Motor Vehicles in Motion'.

The relevant standards use the equivalent continuous rating level as a basis for determining what is acceptable. The levels may take single event noise into account, but single event noise by itself does not determine whether noise levels are acceptable for land use purposes. With regards to SANS 10103:2008, the recommendations are likely to inform decisions by authorities, but non-compliance with the standard will not necessarily render an activity unlawful *per se*.

It must be noted that SANS 10103:2008 does stipulate "*for industries legitimately operating in an industrial district during the entire 24 h day/night cycle,  $L_{Req,d} = L_{Req,n} = 70$  dBA can be considered as typical and normal*".

The SANS 10328:2008 guideline also recommends that the procedures provided in clause 6 to clause 8 in this guideline be followed if:

- a) An application, in respect of any if the activities identified in terms of the current relevant national legislation and noise sources (defined in clauses 3.17 and 3.18), or the issues listed in clause 5, is made to the relevant authority;
- b) An application for a noise-sensitive development (in terms of clause 3.16) is made to the relevant authority;
- c) An application for a change in land use is made to the relevant authority; or
- d) And environmental noise impact investigation is requested by an applicant or any interested or affected party.

The SANS 10328:2008 guideline also sets recommended procedures and minimum requirements for:

- a) an administrative screening procedure and report;
- b) a scoping report;
- c) an environmental noise impact report; or
- d) a review of the environmental investigation report.

## 5.5 INTERNATIONAL GUIDELINES

While a number of international guidelines and standards exists, those selected below are used by numerous countries for environmental noise management. **It should be noted that these guidelines remain in this report only for reference purpose.**

### 5.5.1 Night Noise Guidelines for Europe (WHO, 2009)

Refining previous Community Noise Guidelines issued in 1999, and incorporating more recent research, the World Health Organization has released a comprehensive report on the health effects of night time noise, along with new (non-mandatory) guidelines for use in

Europe. Rather than a maximum of 30 dB inside at night (which equals 45-50 dB max outside), the WHO now recommends a maximum year-round outside night-time noise average of 40 db to avoid sleep disturbance and its related health effects.

**5.5.2 Guidelines for Community Noise (WHO, 1999)**

The World Health Organization’s (WHO) document on the *Guidelines for Community Noise* is the outcome of the WHO expert task force meeting held in London, United Kingdom, in April 1999. It is based on the document entitled “Community Noise” that was prepared for the World Health Organization and published in 1995 by the Stockholm University and Karolinska Institute.

The scope of WHO's effort to derive guidelines for community noise is to consolidate actual scientific knowledge on the health impacts of community noise and to provide guidance to environmental health authorities and professionals trying to protect people from the harmful effects of noise in non-industrial environments

**5.5.3 IFC: General EHS Guidelines – Environmental Noise Management**

These guidelines are applicable to noise created beyond the property boundaries of a development that conforms to the Equator Principles. The environmental standards of the World Bank have been integrated into the social policies of the IFC since April 2007 as the International Finance Corporation Environmental, Health and Safety (EHS) Guidelines.

It sets noise level guidelines (see **Table 5-1**) and highlights the certain monitoring requirements pre- and post-development. It adds another criterion in that the existing background ambient noise level should not rise by more than 3 dBA. This criterion will effectively sterilize large areas of any development. Therefore, it is EARES’s opinion that this criterion was introduced to address cases where the existing ambient noise level is already at, or in excess of the recommended limits.

**Table 5-1: IFC Table .7.1-Noise Level Guidelines**

Receptor type	One hour LAeq (dBA)	
	Daytime 07:00 - 22:00	Night-time 22:00 – 07:00
<b>Residential; institutional; educational</b>	55	45
<b>Industrial; commercial</b>	70	70

The document uses the LAeq,1hr noise descriptors to define noise levels. It does not determine the detection period, but refers to the IEC standards, which requires the fast detector setting on the Sound Level Meter during measurements in Europe.

## 6 ASSUMPTIONS AND LIMITATIONS

### 6.1 AMBIENT SOUND LEVELS

- Ambient sound levels are the cumulative effects of innumerable sounds generated at various instances both far and near. High measurements may not necessarily mean that noise levels in the area are high. Similarly, a low sound level measurement will not necessarily mean that the area is always quiet, as sound levels will vary over seasons, time of the day, faunal characteristics, vegetation in the area and meteorological conditions (especially wind). This is excluding the potential effect of sounds from anthropogenic origin. It is impossible to quantify and identify the numerous sources that influenced one 10-minute measurement using the reading result at the end of the measurement. Therefore trying to define ambient sound levels using the result of one 10-minute measurement will be very inaccurate (very low confidence level in the results) for the reasons mentioned above. The more measurements that can be collected at a location the higher the confidence levels in the ambient sound level determined. The more complex the sound environment, the longer the required measurement. It is assumed that the measurement locations represent other residential dwellings in the area (similar environment), yet, in practice this can be highly erroneous as there are numerous factors that can impact on ambient sound levels, including;
  - the distance to closest trees, number and type of trees as well as the height of trees;
  - available habitat and food for birds and other animals;
  - distance to residential dwelling, type of equipment used at dwelling (compressors, air-cons);
  - general maintenance condition of house (especially during windy conditions); and
  - number and type of animals kept in the vicinity of the measurement locations.
- Determination of existing road traffic and other noise sources of significance are important (traffic counts etc.) – when close to any busy or significant roads. Traffic however is highly dependent on the time of day as well as general agricultural activities taking place during the site investigation. Traffic noise is a significant noise source, especially in urban areas and could be an important source of noise during busy periods.
- Ambient sound levels are depended not only on time of day and meteorological conditions, but also change due to seasonal differences. Ambient sound levels are generally higher in summer months when faunal activity is higher and lower during

the winter due to reduced faunal activity. Winter months also coincide with lower temperatures and very stable atmospheric conditions, ideal conditions for propagation of noise. Many faunal species are more active during warmer periods than colder periods. Certain cicada species can generate noise levels up to 120 dB for mating or distress purposes, sometimes singing in synchronisation magnifying noise levels they produce from their tymbals<sup>2</sup>;

- Ambient sound levels recorded near rivers, streams, wetlands, trees and bushy areas can be high. This is due to faunal activity which can dominate the sound levels around the measurement location. This generally is still considered naturally quiet and understood and accepted as features of the natural soundscape, and in various cases sought after and pleasing;
- Considering more than one sound descriptor or equivalent can improve an acoustical assessment. Parameters such as  $L_{Amin}$ ,  $L_{A1eq}$ ,  $L_{AFeq}$ ,  $L_{Ceq}$ ,  $L_{AMax}$ ,  $L_{A10}$ ,  $L_{A90}$  and spectral analysis forms part of the many variables that can be considered; and
- As an area develops, the increase of people will result in increased sounds. These are generally a combination of traffic noise, voices, animals and equipment (incl. TVs and radios). The result is that ambient sound levels will increase as an area matures.
- Ambient sound levels are generally linked to the developmental nature of an area, with ambient sound levels changing much faster in urban environments than in highly rural areas. Ambient sound levels therefore should be measured more frequently in urban environments. With the project located in the Karoo where residential and urban development is minimal, ambient sound levels due to anthropogenic activities change very slow, if ever and data collected in 2012 would still be valid for this project.

## 6.2 ADEQUACY OF UNDERLYING ASSUMPTIONS

- Noise experienced at a certain location is the cumulative result of innumerable sounds emitted and generated both far and close, each in a different time domain, each having a different spectral character at a different sound level. Each of these sounds are also impacted differently by surrounding vegetation, structures and meteorological conditions that result in a total cumulative noise level represented by a few numbers on a sound level meter.
- It is not the purpose of noise modelling to accurately determine a likely noise level at a certain receptor, but to calculate a noise rating level that is used to identify potential issues of concern.

---

<sup>2</sup> Clyne, D. "Cicadas: Sound of the Australian Summer, *Australian Geographic*" Oct/Dec Vol 56. 1999.

### 6.3 UNCERTAINTIES OF INFORMATION PROVIDED

It is difficult to define the character of a measured noise in terms of numbers (such as third octave sound power levels) and subsequently to accurately model noise levels at a receptor from any operation. The projected noise levels are the output of a numerical model with the accuracy depending on the assumptions made during the setup of the model.

Assumptions include:

- Sound power emission levels from processes and equipment change depending on the load the process and equipment is subject too. While the octave sound power level is the average (equivalent) result of a number of measurements, this measurement relates to a period that the process or equipment was subject to a certain load. Normally these measurements are collected when the process or equipment is under high load;
- The manufacturer of the selected BESS did report a maximum sound level of 50 dB at source when the BESS gets to a certain temperature and require cooling or heating. It is assumed that this sound level is measured at 10m;
- Ambient sound levels vary over time of day, season and largely depend on the complexity and development character of the surrounding environment. Locations close to industrial areas and busy roads generally have ambient sound levels higher than a typical urban residential area.

## 7 METHODOLOGY: SCREENING QUESTIONNAIRE

As the exact noise emission of the propose facility is unknown, the potential noise impact would be evaluated as defined by SANS 10328:2008. This evaluation would be relevant for both the construction and operational phases.

**Table 7-1: Questions for Noise Screening (SANS 10328:2008)**

Question	Answer	Comment
Does the planned linear source (arterial road, planned arterial road reserve, or a main line railway line) at any position along the route pass within 1 000 m from an area which is developed or zoned for residential purposes?	<i>No</i>	<b><i>Not relevant</i></b>
Does the planned linear source (suburban road, planned suburban road reserve where only two lanes of traffic will be present at an average speed limit not exceeding 60 km/h, or a suburban electric traction railway line) at any position along the route pass within 500 m from an area which is developed or zoned for residential purposes?	<i>No</i>	<b><i>Not relevant</i></b>
Does the planned development of a residential area or a piece of land zoned for residential purposes fall within 1 000 m from a planned linear source (arterial road, planned arterial road reserve, or a main line railway line)?	<i>No</i>	<b><i>Not relevant</i></b>
Does the planned development of a residential area or a piece of land zoned for residential purposes fall within 500 m from a planned linear source (suburban road, planned suburban road reserve where only two lanes of traffic will be present at an average speed limit not exceeding 60 km/h, or a suburban electric traction railway line)?	<i>No</i>	<b><i>Not relevant</i></b>
Does a planned industrial development or a building housing a plant fall within a distance of 1 000 m from an already developed residential area or land zoned for residential purposes?	<i>No</i>	<b><i>Not relevant</i></b>
Does a piece of land to be developed for residential purposes or land to be zoned for residential purposes fall within 1 000 m from an already developed industrial area or a building housing plant?	<i>No</i>	<b><i>Not relevant</i></b>
Does planned light industrial development or a building(s) housing workshops fall within a distance of 500 m from an already developed residential area or land zoned for residential purposes?	<i>No</i>	<b><i>Not relevant</i></b>
Does a piece of land to be developed for residential purposes or land to be zoned for residential purposes fall within 500 m from an already developed light industrial development or a building(s) housing workshops?	<i>No</i>	<b><i>Not relevant</i></b>
Does a piece of land to be developed for residential purposes or land to be zoned for residential purposes fall within 2 000 m from an existing wind generator farm?	<i>No</i>	<b><i>Not relevant</i></b>



Question	Answer	Comment
Does a piece of land to be developed as a wind generator farm fall within 2 000 m from a piece of land to be developed for residential purposes or land to be zoned for residential purposes?	No	<b>Not relevant</b>
Does a piece of land to be developed for residential purposes or land to be zoned for residential purposes fall within 2 000 m from a low frequency source (e.g. low speed ventilation fans or low speed diesel engines)?	No	<b>Not relevant</b>
Does an activity containing a low frequency source (e.g. low speed ventilation fans or low speed diesel engines) to be developed fall within 2 000 m from a piece of land to be developed for residential purposes or land use to be zoned for residential purposes?	No	<b>Not relevant</b>
Will the planned repaving of a suburban street be provided with normal, non-sound absorptive bitumen or cement concrete paving?	No	<b>Not relevant</b>
Where an aircraft landing strip, heliport, hoverport or airport is planned, or is to be altered, will this planned activity be such that the calculated appropriate limit noise contour for the full planned use of the activity fall inside the boundaries of any residential area or any piece of land zoned for residential purposes?	No	<b>Not relevant</b>
Where a residential area is planned or a piece of land is to be zoned for residential purposes, will the evaluated appropriate limit noise contour for the full planned use of an aircraft landing strip, heliport, hoverport or airport fall inside the boundaries of the residential area or the piece of land zoned for residential purposes?	No	<b>Not relevant</b>

## **8 CONCLUSIONS AND RECOMMENDATIONS**

Enel Green Power South Africa (Pty) Ltd proposes to develop the Karusa BESS and associated infrastructure in the Northern Cape Province. The BESS facility generates low levels of noise relating to the climate control system, with an audible hum associated with transformers. Considering the potential infrastructure, the proposed infrastructure would be further than 1,000 m from the closest identified NSD.

It is therefore the opinion of the author that there exists no potential for a noise impact and that no further Scoping or other acoustical studies would be required for the proposed BESS and associated infrastructure. No specific mitigation measures regarding noise or additional noise measurements are recommended. No additional conditions regarding noise are recommended for inclusion in the EMPr.

It is therefore recommended that the Karusa BESS and associated infrastructure be approved.

## 9 REFERENCES

In this report reference was made to the following documentation:

1. ADB, 2019: *Handbook on Battery Energy Storage System*. Asian Development Bank, Manila, Philippines
2. Audiology Today, 2010: *Wind-Turbine Noise – What Audiologists should know*
3. De Jager, M. 2012. "Environmental Noise Impact Assessment: Establishment of the Hidden Valley Wind Energy Facility on various farms near the town of Sutherland, Northern Cape Province". M2 Environmental Connections CC, Pretoria.
4. HGC Engineering, 2007: *Wind Turbines and Sound*, report to the Canadian Wind Energy Association
5. Minnesota Department of Health, 2009: *Public Health Impacts of Wind Farms*
6. Renewable Energy Research Laboratory, 2006: *Wind Turbine Acoustic Noise*
7. SANS 10103:2008. 'The measurement and rating of environmental noise with respect to annoyance and to speech communication'.
8. SANS 10210:2004. 'Calculating and predicting road traffic noise'.
9. SANS 10328:2008. 'Methods for environmental noise impact assessments'.
10. SANS 10357:2004 The calculation of sound propagation by the Concave method'.

# **APPENDIX A**

## Glossary of Acoustic Terms, Definitions and General Information

<i>1/3-Octave Band</i>	A filter with a bandwidth of one-third of an octave representing four semitones, or notes on the musical scale. This relationship is applied to both the width of the band, and the centre frequency of the band. See also definition of octave band.
<i>A – Weighting</i>	An internationally standardised frequency weighting that approximates the frequency response of the human ear and gives an objective reading that therefore agrees with the subjective human response to that sound.
<i>Air Absorption</i>	The phenomena of attenuation of sound waves with distance propagated in air, due to dissipative interaction within the gas molecules.
<i>Alternatives</i>	A possible course of action, in place of another, that would meet the same purpose and need (of proposal). Alternatives can refer to any of the following, but are not limited hereto: alternative sites for development, alternative site layouts, alternative designs, alternative processes and materials. In Integrated Environmental Management the so-called “no go” alternative refers to the option of not allowing the development and may also require investigation in certain circumstances.
<i>Ambient</i>	The conditions surrounding an organism or area.
<i>Ambient Noise</i>	The all-encompassing sound at a point being composed of sounds from many sources both near and far. It includes the noise from the noise source under investigation.
<i>Ambient Sound</i>	The all-encompassing sound at a point being composite of sounds from near and far.
<i>Ambient Sound Level</i>	Means the reading on an integrating impulse sound level meter taken at a measuring point in the absence of any alleged disturbing noise at the end of a total period of at least 10 minutes after such a meter was put into operation. In this report the term Background Ambient Sound Level will be used.
<i>Amplitude Modulated Sound</i>	A sound that noticeably fluctuates in loudness over time.
<i>Anthropogenic</i>	Human impact on the environment or anthropogenic impact on the environment includes impacts on <u>biophysical environments</u> , biodiversity and other resources
<i>Applicant</i>	Any person who applies for an authorisation to undertake a listed activity or to cause such activity in terms of the relevant environmental legislation.
<i>Assessment</i>	The process of collecting, organising, analysing, interpreting and communicating data that is relevant to some decision.
<i>Attenuation</i>	Term used to indicate reduction of noise or vibration, by whatever method necessary, usually expressed in decibels.
<i>Audible frequency Range</i>	Generally assumed to be the range from about 20 Hz to 20,000 Hz, the range of frequencies that our ears perceive as sound.
<i>Ambient Sound Level</i>	The level of the ambient sound indicated on a sound level meter in the absence of the sound under investigation (e.g. sound from a particular noise source or sound generated for test purposes). Ambient sound level as per Noise Control Regulations.
<i>Best Practices</i>	A best practice is a method or technique that has consistently shown results superior to those achieved with other means, and that is used as a benchmark. In addition, a "best" practice can evolve to become better as improvements are discovered.
<i>Broadband Noise</i>	Spectrum consisting of a large number of frequency components, none of which is individually dominant.
<i>C-Weighting</i>	This is an international standard filter, which can be applied to a pressure signal or to a <i>SPL</i> or <i>PWL</i> spectrum, and which is essentially a pass-band filter in the frequency range of approximately 63 to 4000 Hz. This filter provides a more constant, flatter, frequency response, providing significantly less adjustment than the A-scale filter for frequencies less than 1000 Hz.
<i>dB(A)</i>	Sound Pressure Level in decibel that has been A-weighted, or filtered, to match the response of the human ear.

<i>Decibel (db)</i>	A logarithmic scale for sound corresponding to a multiple of 10 of the threshold of hearing. Decibels for sound levels in air are referenced to an atmospheric pressure of 20 $\mu$ Pa.
<i>Diffraction</i>	The process whereby an acoustic wave is disturbed and its energy redistributed in space as a result of an obstacle in its path, Reflection and refraction are special cases of diffraction.
<i>Direction of Propagation</i>	The direction of flow of energy associated with a wave.
<i>Disturbing noise</i>	Means a noise level that exceeds the zone sound level or, if no zone sound level has been designated, a noise level that exceeds the ambient sound level at the same measuring point by 7 dBA or more.
<i>Echolocation</i>	Echo locating animals emit calls out to the environment and listen to the <u>echoes</u> of those calls that return from various objects near them. They use these echoes to locate and identify the objects. Echolocation is used for <u>navigation</u> and for foraging (or hunting) in various environments.
<i>Environment</i>	The external circumstances, conditions and objects that affect the existence and development of an individual, organism or group; these circumstances include biophysical, social, economic, historical, cultural and political aspects.
<i>Environmental Control Officer</i>	Independent Officer employed by the applicant to ensure the implementation of the Environmental Management Plan (EMP) and manages any further environmental issues that may arise.
<i>Environmental impact</i>	A change resulting from the effect of an activity on the environment, whether desirable or undesirable. Impacts may be the direct consequence of an organisation's activities or may be indirectly caused by them.
<i>Environmental Impact Assessment</i>	An Environmental Impact Assessment (EIA) refers to the process of identifying, predicting and assessing the potential positive and negative social, economic and biophysical impacts of any proposed project, plan, programme or policy that requires authorisation of permission by law and that may significantly affect the environment. The EIA includes an evaluation of alternatives, as well as recommendations for appropriate mitigation measures for minimising or avoiding negative impacts, measures for enhancing the positive aspects of the proposal, and environmental management and monitoring measures.
<i>Environmental issue</i>	A concern felt by one or more parties about some existing, potential or perceived environmental impact.
<i>Equivalent continuous A-weighted sound exposure level (<math>L_{Aeq,T}</math>)</i>	The value of the average A-weighted sound pressure level measured continuously within a reference time interval $T$ , which have the same mean-square sound pressure as a sound under consideration for which the level varies with time.
<i>Equivalent continuous A-weighted rating level (<math>L_{Req,T}</math>)</i>	The Equivalent continuous A-weighted sound exposure level ( $L_{Aeq,T}$ ) to which various adjustments has been added. More commonly used as ( $L_{Req,d}$ ) over a time interval 06:00 – 22:00 ( $T=16$ hours) and ( $L_{Req,n}$ ) over a time interval of 22:00 – 06:00 ( $T=8$ hours). It is a calculated value.
<i>F (fast) time weighting</i>	(1) Averaging detection time used in sound level metre. (2) Fast setting has a time constant of 125 milliseconds and provides a fast reacting display response allowing the user to follow and measure not too rapidly fluctuating sound.
<i>Footprint area</i>	Area to be used for the construction of the proposed development, which does not include the total study area.
<i>Free Field Condition</i>	An environment where there is no reflective surfaces.
<i>Frequency</i>	The rate of oscillation of a sound, measured in units of Hertz (Hz) or kiloHertz (kHz). One hundred Hz is a rate of one hundred times per second. The frequency of a sound is the property perceived as pitch: a low-frequency sound (such as a bass note) oscillates at a relatively slow rate, and a high-frequency sound (such as a treble note) oscillates at a relatively high rate.

<i>Green field</i>	A parcel of land not previously developed beyond that of agriculture or forestry use; virgin land. The opposite of Greenfield is Brownfield, which is a site previously developed and used by an enterprise, especially for a manufacturing or processing operation. The term Brownfield suggests that an investigation should be made to determine if environmental damage exists.
<i>G-Weighting</i>	An International Standard filter used to represent the infrasonic components of a sound spectrum.
<i>Harmonics</i>	Any of a series of musical tones for which the frequencies are integral multiples of the frequency of a fundamental tone.
<i>I (impulse) time weighting</i>	(1) Averaging detection time used in sound level metre as per South African standards and Regulations. (2) Impulse setting has a time constant of 35 milliseconds when the signal is increasing (sound pressure level rising) and a time constant of 1,500 milliseconds while the signal is decreasing.
<i>Impulsive sound</i>	A sound characterized by brief excursions of sound pressure (transient signal) that significantly exceed the ambient sound level.
<i>Infrasound</i>	Sound with a frequency content below the threshold of hearing, generally held to be about 20 Hz. Infrasonic sound with sufficiently large amplitude can be perceived, and is both heard and felt as vibration. Natural sources of infrasound are waves, thunder and wind.
<i>Integrated Development Plan</i>	A participatory planning process aimed at developing a strategic development plan to guide and inform all planning, budgeting, management and decision-making in a Local Authority, in terms of the requirements of Chapter 5 of the Municipal Systems Act, 2000 (Act 32 of 2000).
<i>Integrated Environmental Management</i>	IEM provides an integrated approach for environmental assessment, management, and decision-making and to promote sustainable development and the equitable use of resources. Principles underlying IEM provide for a democratic, participatory, holistic, sustainable, equitable and accountable approach.
<i>Interested and affected parties</i>	Individuals or groups concerned with or affected by an activity and its consequences. These include the authorities, local communities, investors, work force, consumers, environmental interest groups and the general public.
<i>Key issue</i>	An issue raised during the Scoping process that has not received an adequate response and that requires further investigation before it can be resolved.
<i>Listed activities</i>	Development actions that is likely to result in significant environmental impacts as identified by the delegated authority (formerly the Minister of Environmental Affairs and Tourism) in terms of Section 21 of the Environment Conservation Act.
<i>L<sub>AMin</sub> and L<sub>AMax</sub></i>	Is the RMS (root mean squared) minimum or maximum level of a noise source.
<i>Loudness</i>	The attribute of an auditory sensation that describes the listener's ranking of sound in terms of its audibility.
<i>Magnitude of impact</i>	Magnitude of impact means the combination of the intensity, duration and extent of an impact occurring.
<i>Masking</i>	The raising of a listener's threshold of hearing for a given sound due to the presence of another sound.
<i>Mitigation</i>	To cause to become less harsh or hostile.
<i>Natural Sounds</i>	Are sounds produced by natural sources in their normal baseline.
<i>Negative impact</i>	A change that reduces the quality of the environment (for example, by reducing species diversity and the reproductive capacity of the ecosystem, by damaging health, or by causing nuisance).
<i>Noise</i>	a. Sound that a listener does not wish to hear (unwanted sounds). b. Sound from sources other than the one emitting the sound it is desired to receive, measure or record. c. A class of sound of an erratic, intermittent or statistically random nature.
<i>Noise Level</i>	The term used in lieu of sound level when the sound concerned is being measured or ranked for its undesirability in the contextual circumstances.

<i>Noise-sensitive development</i>	<p>developments that could be influenced by noise such as:</p> <p>a) districts (see table 2 of SANS 10103:2008)</p> <ol style="list-style-type: none"> <li>1. rural districts,</li> <li>2. suburban districts with little road traffic,</li> <li>3. urban districts,</li> <li>4. urban districts with some workshops, with business premises, and with main roads,</li> <li>5. central business districts, and</li> <li>6. industrial districts;</li> </ol> <p>b) educational, residential, office and health care buildings and their surroundings;</p> <p>c) churches and their surroundings;</p> <p>d) auditoriums and concert halls and their surroundings;</p> <p>e) recreational areas; and</p> <p>f) nature reserves.</p> <p>In this report Noise-sensitive developments is also referred to as a Potential Sensitive Receptor</p>
<i>Octave Band</i>	A filter with a bandwidth of one octave, or twelve semi-tones on the musical scale representing a doubling of frequency.
<i>Positive impact</i>	A change that improves the quality of life of affected people or the quality of the environment.
<i>Property</i>	Any piece of land indicated on a diagram or general plan approved by the Surveyor-General intended for registration as a separate unit in terms of the Deeds Registries Act and includes an erf, a site and a farm portion as well as the buildings erected thereon
<i>Public Participation Process</i>	A process of involving the public in order to identify needs, address concerns, choose options, plan and monitor in terms of a proposed project, programme or development
<i>Reflection</i>	Redirection of sound waves.
<i>Refraction</i>	Change in direction of sound waves caused by changes in the sound wave velocity, typically when sound wave propagates in a medium of different density.
<i>Reverberant Sound</i>	The sound in an enclosure which results from repeated reflections from the boundaries.
<i>Reverberation</i>	The persistence, after emission of a sound has stopped, of a sound field within an enclosure.
<i>Significant Impact</i>	An impact can be deemed significant if consultation with the relevant authorities and other interested and affected parties, on the context and intensity of its effects, provides reasonable grounds for mitigating measures to be included in the environmental management report. The onus will be on the applicant to include the relevant authorities and other interested and affected parties in the consultation process. Present and potential future, cumulative and synergistic effects should all be taken into account.
<i>S (slow) time weighting</i>	<p>(1) Averaging times used in sound level metre.</p> <p>(2) Time constant of one [1] second that gives a slower response which helps average out the display fluctuations.</p>
<i>Sound Level</i>	The level of the frequency and time weighted sound pressure as determined by a sound level meter, i.e. A-weighted sound level.
<i>Sound Power</i>	Of a source, the total sound energy radiated per unit time.
<i>Sound Pressure Level (SPL)</i>	Of a sound, 20 times the logarithm to the base 10 of the ratio of the RMS sound pressure level to the reference sound pressure level. International values for the reference sound pressure level are 20 micropascals in air and 100 millipascals in water. SPL is reported as $L_p$ in dB (not weighted) or in various other weightings.
<i>Study area</i>	Refers to the entire study area encompassing all the alternative routes as indicated on the study area map.
<i>Sustainable Development</i>	Development that meets the needs of the present without compromising the ability of future generations to meet their own needs. It contains within it two key concepts: the concept of "needs", in particular the essential needs of the



		world's poor, to which overriding priority should be given; and the idea of limitations imposed by the state of technology and social organization on the environment's ability to meet present and the future needs (Brundtland Commission, 1987).
<i>Tone</i>		Noise can be described as tonal if it contains a noticeable or discrete, continuous note. This includes noises such as hums, hisses, screeches, drones, etc. and any such subjective description is open to discussion and contradiction when reported.
<i>Zone of Potential Influence</i>		The area defined as the radius about an object, or objects beyond which the noise impact will be insignificant.
<i>Zone Sound Level</i>		Means a derived dBA value determined indirectly by means of a series of measurements, calculations or table readings and designated by a local authority for an area. This is similar to the Rating Level as defined in SANS 10103:2008.

**End of Report**