

BLOEMFONTEIN OFFICE

info@ekogroup.co.za

t +27(0)51 444 4700

f +27(0)86 653 5718

Suite 227 Private Bag X01

BRANDHOF 9324

OFFICES: Vryheid Kimberley Port Elizabeth



EKO GROUP (PTY) LTD trading as Eko Environmental
Reg no. 2017/311178/07
VAT No. 4020225811

FINAL BAR AND EMPr:

PROPOSED ESTABLISHMENT OF THE STERKSPRUIT
REGIONAL WASTE WATER TREATMENT WORKS
(WWTW) AND ASSOCIATED BULK INFRASTRUCTURE IN
SENQU LOCAL MUNICIPALITY, EASTERN CAPE
PROVINCE

DEDEAT Ref. No.: EC 142/JG/LN1/M/20/04

Case Officer: Mr T Babane

Email: thozamile.babane@dedea.gov.za

March 2021

Applicant:

Joe Gqabi District Municipality represented by Dibabani Consulting CC

Contact person: Mr P.F.R Swanepoel
3 Woodland Hills
Boulevard
Address: Bloemfontein
9301
Tel: 051 451 1814

BLOEMFONTEIN OFFICE

info@ekogroup.co.za

t +27(0)51 444 4700

f +27(0)86 653 5718

Suite 227 Private Bag X01

BRANDHOF 9324

OFFICES: Vryheid Kimberley Port Elizabeth



EKO GROUP (PTY) LTD trading as Eko Environmental

Reg no. 2017/311178/07

VAT No. 4020225811

Prepared by:

PROJECT TEAM

Environmental Assessment Practitioner(s): Richard Williamson of EKO Environmental

Postal address: Suite 227
Private Bag X01
Brandhof
9324

Contact person(s): Richard Williamson

Tel: 051 444 4700

Fax: 086 697 6132

E-mail: richard@ekogroup.co.za

info@ekogroup.co.za

Case officer: Mr Thozamile Babane

Email: Thozamile.babane@dedea.gov.za

Tel: 051 633 2901



BASIC ASSESSMENT REPORT

(For official use only)

File Reference Number:

NEAS Number:

Date Received:

Basic assessment report in terms of the Environmental Impact Assessment Regulations, 2014 as amended, promulgated in terms of the National Environmental Management Act, 1998(Act No. 107 of 1998), as amended.

Kindly note that:

1. This basic assessment report is a standard report that may be required by a competent authority in terms of the EIA Regulations, 2014 as amended and is meant to streamline applications. Please make sure that it is the report used by the particular competent authority for the activity that is being applied for.
2. The report must be typed within the spaces provided in the form. The size of the spaces provided is not necessarily indicative of the amount of information to be provided. The report is in the form of a table that can extend itself as each space is filled with typing.
3. Where applicable tick the boxes that are applicable or black out the boxes that are not applicable in the report.
4. An incomplete report may be returned to the applicant for revision.
5. **The use of “not applicable”** in the report must be done with circumspection because if it is used in respect of material information that is required by the competent authority for assessing the application, it may result in the rejection of the application as provided for in the regulations.
6. This report must be handed in at offices of the relevant competent authority as determined by each authority.
7. No faxed or e-mailed reports will be accepted.
8. The report must be compiled by an independent environmental assessment practitioner (EAP).

“Innovation for Sustainable Development”



9. Unless protected by law, all information in the report will become public information on receipt by the competent authority. Any interested and affected party should be provided with the information contained in this report on request, during any stage of the application process.
10. A competent authority may require that for specified types of activities in defined situations only parts of this report need to be completed.

“Innovation for Sustainable Development”



SECTION A: ACTIVITY INFORMATION

Has a specialist been consulted to assist with the completion of this section?

YES	NO
-----	----

If YES, please complete form XX for each specialist thus appointed:

Any specialist reports must be contained in Appendix D.

1. ACTIVITY DESCRIPTION

Describe the activity, which is being applied for, in detail

Description of the project

The project entails the replacement of the Sterkspruit Regional Waste Water Treatment Works (WWTW) and associated bulk infrastructure. Dibanani Consulting has been appointed to apply, on behalf of Joe Gqabi District Municipality, for Environmental Authorisation and thereafter to construct a WWTW as well as lift pump stations and bulk connector services. The bulk connector sewer system will service Sterkspruit, Eslindini, Mogesi and Tapoleng townships.

The proposed WWTW site falls within the D12A quaternary drainage area within the Upper Orange Water Management Area. The Kromspruit is a tributary of the Orange River with its confluence approximately 60 km (linear distance) upstream of Aliwal North. The Sterkspruit sewage treatment plant is located approximately 6 km (linear distance) south-east of the Kromspruit-Orange River confluence.

Groundwater occurs as inter-granular and/or fractured zone aquifers. There are no high yielding aquifers in a 1 km radius of the site that are developed. Groundwater is mainly used for livestock watering and domestic use where no surface water resources are available and that is not serviced by means of the local water reticulation network. The average yield of boreholes in the area is between 0.1 and 0.5 l/s.

The average rainfall in the area is between 600-700 mm per annum which occurs largely as thunderstorms between November and April. The surface water runoff in the area is typically

“Innovation for Sustainable Development”



restricted to very high rainfall events with an estimate mean annual runoff of between 100 – 200 mm per annum (Water Resources of South Africa, 2005 Study, WR2005).

The replacement of the sewage bulk connector systems entails the division of the systems into three major drainage zones, one for each community. The replacement will aim to maximise the delivery of sewer services to the communities. The communities of Sterkspruit, Esilindini, Tapoleng and Mokhesi will all be serviced and connected to the WWTW by these bulk connector systems.

The sewer connector services will consist out of the following infrastructure:

- The construction of 1200 m of 160 mm diameter sewer pump lines.
- The construction of 6000 m of 200 mm diameter sewer pipes.
- The construction of 12000 m of 250 mm diameter sewer pipes.
- The construction of 5000 m of 355 mm diameter sewer pipes.
- The construction of 2000 m of 400 mm diameter sewer pipes.
- The construction of 350 manholes.

The WWTW will be replaced and will have an initial capacity of 4Ml per day. The final effluent will be irrigated onto sports fields and other designated irrigation areas. This 4Ml capacity will be sufficient for 5 years and will accommodate all excess sewage that the current WWTW cannot handle. After the 5-year period the WWTW will be upgraded to handle 7Ml per day. During this upgrade the re-use of the final effluent will be investigated or the installation of an outfall sewer to evaporation dams will be investigated.

The WWTW will consist of amongst others:

- Inlet works with screening and de-gritting
- Flow measurements
- Biological reactor
- Secondary sedimentation tanks
- Maturation rivers

The process that will be used for the WWTW will be the well-known and proven "three-stage Phoredox" activated sludge treatment process. The main objective will be to re-use as much of the water for irrigation of fodder, town gardens and sport fields.

"Innovation for Sustainable Development"



The eventual 6 MI per day WWTW will be constructed over three phases:

Flow description	Phase 1	Phase 2	Phase 3
Description of work	2.5MI/d inlet works, 3460m ³ reactor, 22m diameter Secondary Sedimentation Tanks (SST) with chlorination channels, chlorination building, control building	Petro division box, facultative pond 2500 m ³ , Petro recycle pump station and pipe work	Mirror of phase 1 and 2. Construct 5 MI/d inlet works, additional 3460 m ³ reactor, additional 22m diameter SST with chlorination channels (30 min contact time)
Structures shared from previous phases		Share 2.5 MI/d inlet works, chlorination channels, chlorination building and control building	Share chlorination building and control building
ADWF capacity	1712 m ³ /d	2440 m ³ /d	4880 m ³ /d
PDWF	4491 m ³ /d	6037 m ³ /d	12 635 m ³ /d
Number of stands	3058 stands	4366 stands	8732 stands

The different components and stages within the WWTW will consist of:

- Inlet works where raw sewage will enter the plant from the bulk connector system.
- Reactors which will facilitate aeration by means of six vertical shaft aerators.
- Secondary Settling Tanks (SST) which will enable settling of solids and separation of water.
- Petro system oxidation secondary ponds which will enable aerobic sludge digestion which will further aid in an increase in sludge storage capacity.
- Effluent from the chlorination basin will be discharged through a series of maturation channels. The channels will be shaped according to the natural contours on the site.

“Innovation for Sustainable Development”



The channels are approximately three meters wide with a maximum depth of 300 mm. These channels will be planted with reed.

- Gas chlorination will be done with auto-change over and in accordance with SANS requirements.

A series of lift pump stations will also be constructed to accommodate the bulk connector services where gravitational feeds cannot carry any raw sewage to the WWTW. A total of 7 sewer lift pump stations will be constructed along bulk connector systems.

The following specifications will be applicable to the pump stations:

- 20-hour pumping per day.
- Sized for the summer peak demand
- Sized for a minimum of 33% standby capacity.

Due to the fact that the existing WWTW is overloaded at present it is of critical importance that the construction of the new WWTW commence. From the once-off water quality date and a visual assessment of the river status it is clear that the spruit are affected by sub-standard water from sewage origin enter the system. This is mainly overflows as a result of overflow from sewage blockages, runoff from poorly reticulated areas and the seepage from the existing maturation ponds.

The upgrade of the Sterkfontein STP will have a significant positive impact on the general river health in the Kromspruit. For detailed specifications and description of the WWTW and associated pipelines please refer to Appendix G and the technical feasibility report and technical write-up.

Description of the environment

Joe Gqabi District Municipality is mainly a rural community with a large proportion of people residing in traditional villages surrounding the CBD. Sterkspruit is the business hub that is serving the surrounding areas. The project area comprises of four settlements in the Joe Gqabi District Municipality i.e. Sterkspruit, Esilindini, Tapoleng and Mokhesi.

Currently about 113 households in Sterkspruit are serviced with a full waterborne sewage system. Government institutions such as the prison, municipal offices, police station and a few businesses in the CBD are also connected to the current sewer reticulation system. The areas of Esilindini, Tapoleng and Mokhesi does not currently have any access to any formal sewer

“Innovation for Sustainable Development”



systems. Currently all of the sewers are buckets and or dry systems. The existing WWTW and oxidation ponds at the northern side of Sterkspruit are filled to capacity and effluent is overflowing into the river.

The existing bulk sewage supply pipeline connecting Sterkspruit with the oxidation ponds is partially constructed on the banks of the Kromspruit River. At some places where the banks of the river has eroded away by flood waters, it exposed the sewer pipeline and caused it to break at critical places. Temporary repairs to the pipeline do not seem to be sufficient and are also temporary in nature.

The new WWTW will be situated on the Remainder of Erf 1. This area also contains the existing WWTW that is currently being operated. This area is highly degraded and transformed. The WWTW is situated within a bend in the Kromspruit and is situated between 20 and 30 meters from the river. The existing maturation ponds are not lined with clear evidence on the banks of the stream that water is seeping into the spruit. There is no evidence of a constant overflow into the spruit, but it is very likely that discharge to the spruit occurred in the past especially during high rainfall events. The existing WWTW consists of a small inlet and a large oxidation pond where the sewage matures before flowing into the Kromspruit. A large portion of the site has also been converted to irrigated grazing but is not operational at present.

The following is a description of the pipeline routes:

Phase 1

The pipeline will run from the WWTW through the CBD along the existing road reserve and to the east of the WWTW where it will service the area of Wittenberg.

A portion of the pipeline will also run along the R392 tarred road to the west of the WWTW and will then turn south to the area of Tapoleng, Masekeleng and Tienbank.

Phase 2

The pipeline will run west from the WWTW along the R392 tarred road. The pipeline will split off and turn south to the area of Mfirikini, Zwelitsha and Etshantolo. The remainder of this pipeline will continue along the tarred road and will terminate near the areas of Kwantoyi and Emadlangeni.

Phase 3

The pipeline will run south of the WWTW and will cross the Kromspruit from where it will run along the R392 tarred road north to the area of Mareteng. The pipeline will also split off to the

“Innovation for Sustainable Development”



area of Sekotong.

2. FEASIBLE AND REASONABLE ALTERNATIVES

“alternatives”, in relation to a proposed activity, means different means of meeting the general purpose and requirements of the activity, which may include alternatives to—

- (a) the property on which or location where it is proposed to undertake the activity;
- (b) the type of activity to be undertaken;
- (c) the design or layout of the activity;
- (d) the technology to be used in the activity;
- (e) the operational aspects of the activity; and
- (f) the option of not implementing the activity.

Describe alternatives that are considered in this application. Alternatives should include a consideration of all possible means by which the purpose and need of the proposed activity could be accomplished in the specific instance taking account of the interest of the applicant in the activity. The no-go alternative must in all cases be included in the assessment phase as the baseline against which the impacts of the other alternatives are assessed. The determination of whether site or activity (including different processes etc.) or both is appropriate needs to be informed by the specific circumstances of the activity and its environment. After receipt of this report the competent authority may also request the applicant to assess additional alternatives that could possibly accomplish the purpose and need of the proposed activity if it is clear that realistic alternatives have not been considered to a reasonable extent.

Paragraphs 3 – 13 below should be completed for each alternative.

Note: The WWTW will be constructed at the existing oxidation ponds near the northern boundary of Sterkspruit near the banks of the Kromspruit River where the existing WWTW is situated. The WWTW will utilise the existing oxidation ponds which will be upgraded. Due to this the existing site will have to be utilised for the WWTW and no site alternatives were assessed.

A technological alternative which has been considered is retaining the oxidation ponds and not upgrading the WWTW to an activated sludge system. This has several implications which renders this alternative unfeasible. Firstly, the current oxidation ponds are too small and the

“Innovation for Sustainable Development”



volume required to accommodate the population of Sterkspruit and surrounding communities will be too large. The current site location is also unable to accommodate the oxidation ponds required to handle the volumes. Oxidation pond treatment systems also do not treat the water to the same quality standard as an activated sludge system. The treated water used in the alternative will also have to be irrigated in some area. The current site does not have the available land space requirements where the treated water could be irrigated.



3. ACTIVITY POSITION

Indicate the position of the activity using the latitude and longitude of the centre point of the site for each alternative site. The co-ordinates should be in degrees and decimal minutes. The minutes should have at least three decimals to ensure adequate accuracy. The projection that must be used in all cases is the WGS84 spheroid in a national or local projection.

List alternative sites if applicable.

Alternative:

Latitude (S):

Longitude (E):

Alternative S1¹ (preferred or only site alternative)

30°	31.311'	27°	21.847'
30°	31.311'	27°	21.847'
0	'	0	'

Alternative S2 (*oxidation ponds*)

Alternative S3 (if any)

In the case of linear activities:

Alternative:

Latitude (S):

Longitude (E):

Alternative S1 (preferred or only route alternative)

- Starting point of the activity
- Middle point of the activity
- End point of the activity

0	'	0	'
0	'	0	'
0	'	0	'

Alternative S2 (if any)

- Starting point of the activity
- Middle point of the activity
- End point of the activity

0	'	0	'
0	'	0	'
0	'	0	'

Alternative S3 (if any)

- Starting point of the activity
- Middle point of the activity
- End point of the activity

0	'	0	'
0	'	0	'
0	'	0	'

For route alternatives that are longer than 500m, please provide an addendum with co-ordinates taken every 250 meters along the route for each alternative alignment.

Note: Please refer to Appendix G for a list of coordinates for the bulk connector systems.

¹ "Alternative S.." refer to site alternatives.



4. PHYSICAL SIZE OF THE ACTIVITY

Indicate the physical size of the preferred activity/technology as well as alternative activities/technologies (footprints):

Alternative:

Alternative A1² (preferred activity alternative)

Alternative A2 (if any)

Alternative A3 (if any)

Size of the activity:

35 995 m ²

150 000 m ²

m ²

or, for linear activities:

Alternative:

Alternative A1 (preferred activity alternative)

Alternative A2 (if any)

Alternative A3 (if any)

Length of the activity:

26 200 m

m

m

Indicate the size of the alternative sites or servitudes (within which the above footprints will occur):

Alternative:

Alternative A1 (preferred activity alternative)

Alternative A2 (if any)

Alternative A3 (if any)

Size of the
site/servitude:

m ²

m ²

m ²

5. SITE ACCESS

Does ready access to the site exist?

YES	NO
-----	----

If NO, what is the distance over which a new access road will be built

m

Describe the type of access road planned:

Access to the site already exists.

Include the position of the access road on the site plan and required map, as well as an indication of the road in relation to the site.

² "Alternative A.." refer to activity, process, technology or other alternatives.



6. SITE OR ROUTE PLAN

A detailed site or route plan(s) must be prepared for each alternative site or alternative activity. It must be attached as Appendix A to this document.

The site or route plans must indicate the following:

- 6.1 the scale of the plan which must be at least a scale of 1:500;
- 6.2 the property boundaries and numbers of all the properties within 50 metres of the site;
- 6.3 the current land use as well as the land use zoning of each of the properties adjoining the site or sites;
- 6.4 the exact position of each element of the application as well as any other structures on the site;
- 6.5 the position of services, including electricity supply cables (indicate above or underground), water supply pipelines, boreholes, street lights, sewage pipelines, storm water infrastructure and telecommunication infrastructure;
- 6.6 all trees and shrubs taller than 1.8 metres;
- 6.7 walls and fencing including details of the height and construction material;
- 6.8 servitudes indicating the purpose of the servitude;
- 6.9 sensitive environmental elements within 100 metres of the site or sites including (but not limited thereto):
 - rivers;
 - the 1:100 year flood line (where available or where it is required by DWA);
 - ridges;
 - cultural and historical features;
 - areas with indigenous vegetation (even if it is degraded or invested with alien species);
- 6.9 for gentle slopes the 1 metre contour intervals must be indicated on the plan and whenever the slope of the site exceeds 1:10, the 500mm contours must be indicated on the plan; and
- 6.10 the positions from where photographs of the site were taken.

“Innovation for Sustainable Development”



7. SITE PHOTOGRAPHS

Colour photographs from the centre of the site must be taken in at least the eight major compass directions with a description of each photograph. Photographs must be attached under Appendix B to this form. It must be supplemented with additional photographs of relevant features on the site, if applicable.

8. FACILITY ILLUSTRATION

A detailed illustration of the activity must be provided at a scale of 1:200 as Appendix C for activities that include structures. The illustrations must be to scale and must represent a realistic image of the planned activity. The illustration must give a representative view of the activity.

9. ACTIVITY MOTIVATION

9(a) Socio-economic value of the activity

What is the expected capital value of the activity on completion?

R	109
Million	

What is the expected yearly income that will be generated by or as a result of the activity?

N/A

Will the activity contribute to service infrastructure?

YES	NO
-----	----

Is the activity a public amenity?

YES	NO
-----	----

How many new employment opportunities will be created in the development phase of the activity?

N/A

What is the expected value of the employment opportunities during the development phase?

N/A

What percentage of this will accrue to previously disadvantaged individuals?

N/A

How many permanent new employment opportunities will be created during the operational phase of the activity?

N/A

“Innovation for Sustainable Development”



What is the expected current value of the employment opportunities during the first 10 years?

N/A

What percentage of this will accrue to previously disadvantaged individuals?

N/A

Note: The project will form part of the municipal infrastructure for the area. The project therefore forms part of basic services and will not generate any annual income. The contractor responsible for construction of the WWTW and bulk connector systems will be employed through a tender process which will determine the employment during the construction phase. Employment during construction will be done according to the conditions as set out by the municipality within the contract. Employment at the WWTW during operation will be determined by the municipality.

9(b) Need and desirability of the activity

Motivate and explain the need and desirability of the activity (including demand for the activity):

The existing oxidation ponds at the northern side of the Kromspruit alongside the Kromspruit River are filled to capacity and effluent is periodically overflowing into the river.

The existing bulk sewage supply pipeline connecting Sterkspruit with the oxidation ponds are partially constructed on the banks of the Kromspruit. At some places where the banks of the river have been eroded by floods it has exposed the sewer pipeline and caused it to break at critical places. Temporary repairs to the pipeline are inadequate.

Currently about 113 households in Sterkspruit are serviced with a full waterborne sewage system. Government institutions such as the prison, municipal offices, police station and a few businesses in the CBD are also connected to the current sewer reticulation system.

The areas of Esilindini, Tapoleng and Mokhesi do not currently have any access to any formal sewer systems. Currently all of the sewers are buckets and or dry systems.

Due to the fact that the existing WWTW is overloaded at present, it is of critical importance that the first phase of the WWTW and bulk connector services be implemented.

Indicate any benefits that the activity will have for society in general:

“Innovation for Sustainable Development”



The project will ultimately have many positive benefits to society, especially the local community. Firstly, the WWTW and bulk connector systems will alleviate large-scale pollution of the Sterkspruit, Kromspruit and groundwater by raw sewage. This will increase the health of the river system. The Kromspruit flows into the Orange River not far from the site and therefore the WWTW will also increase the health of the Orange River, **one of South Africa's most important river systems**. This will have a national positive impact. The health hazard for people utilizing the Kromspruit and Orange River will also decrease, especially those using the Kromspruit river.

The WWTW and bulk connector system will lay the foundations for the installation of waterborne flush systems throughout the townships of Sterkspruit, Esilindini, Tapoleng and Mokhesi. This will entail a major positive benefit for the area and communities.

Indicate any benefits that the activity will have for the local communities where the activity will be located:

The project will largely benefit the local community.

The WWTW and bulk connector system will lay the foundations for the installation of waterborne flush systems throughout the township of Sterkspruit, Esilindini, Tapoleng and Mokhesi. This will entail a major positive benefit for the area.

10. APPLICABLE LEGISLATION, POLICIES AND/OR GUIDELINES

List all legislation, policies and/or guidelines of any sphere of government that are applicable to the application as contemplated in the EIA regulations, if applicable:

Title of legislation, policy or guideline:	Administering authority:	Date:
National Environmental Management Act (Act No 107 of 1999)	Department of Environment, Forestry and Fisheries	1998
National Water Act (Act 36 of 1998)	Department of Water And Sanitation	1998
National Heritage Resources Act (No 25 of 1999)	Department of Arts and	1999

"Innovation for Sustainable Development"



	Culture	
--	---------	--

11. WASTE, EFFLUENT, EMISSION AND NOISE MANAGEMENT

11(a) Solid waste management

Will the activity produce solid construction waste during the construction/initiation phase?

YES	NO
-----	----

If yes, what estimated quantity will be produced per month?

20 m ³

How will the construction solid waste be disposed of (describe)?

Construction solid waste will be stockpiled on the site and removed on a weekly basis to be disposed of at the local landfill site (Sterkspruit Landfill Site/Lady Grey Landfill Site whichever area has sufficient capacity to accommodate solid waste).

Where will the construction solid waste be disposed of (describe)?

All construction solid waste will be disposed of at the Sterkspruit or Lady Grey Landfill Site whichever site has sufficient capacity to accommodate solid waste.

Will the activity produce solid waste during its operational phase?

YES	NO
-----	----

If yes, what estimated quantity will be produced per month?

Refer to note below.

How will the solid waste be disposed of (describe)?



Note: The site currently contains an oxidation pond. New sludge lagoons will be constructed on top of this oxidation pond. Upon consultation between the engineers and the municipality it has been concluded that the local Sterkspruit landfill site does not currently have capacity for the accumulated sludge within the existing oxidation ponds. The best course of action for the construction of the new sludge lagoons will be to rehabilitate the current oxidation pond by means of capping the existing oxidation pond and constructing the new sludge lagoons on top. In this manner the existing oxidation pond will be contained within capped clay layers which will prevent infiltration and pollution of the groundwater as well as the surrounding environment. The following figure will illustrate this:

Existing oxidation pond:

Existing oxidation pond:



Rehabilitated oxidation pond and newly constructed sludge lagoon:

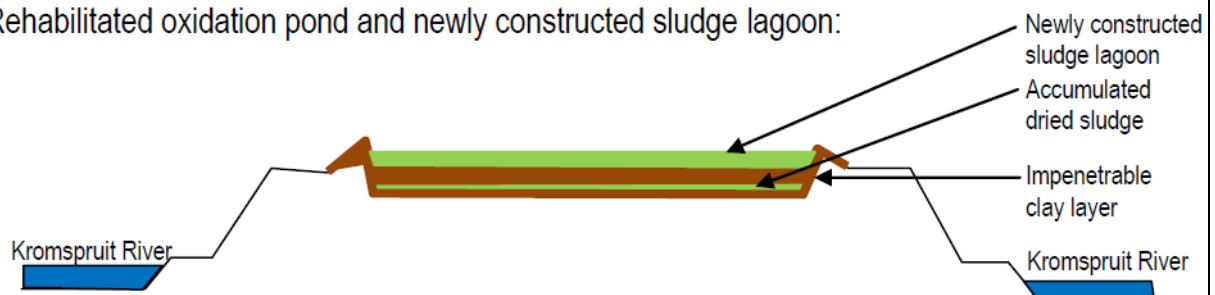

The newly constructed sludge lagoon will have a lifetime of 20 years before it will require desludging. This will be the only period when the WWTW will produce solid waste. The expected volume of sludge to be disposed of at this time will be approximately 500 m³. This sludge waste will then be disposed of in accordance with the Department of Water and Sanitation, Guideline for Permissible Utilisation and Disposal of Wastewater Sludge Volume 3: Requirements for the on-site and off-site disposal of sludge (2009) which is currently available or whichever may be available at that time. The possible options for the disposal include the current new landfill site which is still in the planning phase and which can be

“Innovation for Sustainable Development”



investigated for the disposal of the sludge. Alternatively sludge may then be used as fertiliser on surrounding fields.

Where will the solid waste be disposed if it does not feed into a municipal waste stream (describe)?

See above

If the solid waste (construction or operational phases) will not be disposed of in a registered landfill site or be taken up in a municipal waste stream, then the applicant should consult with the competent authority to determine whether it is necessary to change to an application for scoping and EIA.

Can any part of the solid waste be classified as hazardous in terms of the relevant legislation?

YES	NO
-----	----

If yes, inform the competent authority and request a change to an application for scoping and EIA.

Is the activity that is being applied for a solid waste handling or treatment facility?

YES	NO
-----	----

If yes, then the applicant should consult with the competent authority to determine whether it is necessary to change to an application for scoping and EIA.

11(b) Liquid effluent

Will the activity produce effluent, other than normal sewage, that will be disposed of in a municipal sewage system?

YES	NO
-----	----

If yes, what estimated quantity will be produced per month?

m ³	
----------------	--

Will the activity produce any effluent that will be treated and/or disposed of on site?

Yes	NO
-----	----

If yes, the applicant should consult with the competent authority to determine whether it is necessary to change to an application for scoping and EIA.

Will the activity produce effluent that will be treated and/or disposed of at another facility?

YES	NO
-----	----

“Innovation for Sustainable Development”



If yes, provide the particulars of the facility: _____

Facility name:			
Contact person:			
Postal address:			
Postal code:			
Telephone:		Cell:	
E-mail:		Fax:	

Describe the measures that will be taken to ensure the optimal reuse or recycling of waste water, if any:

Treated water will be utilised for irrigation of sports fields and other designated irrigation areas. Treated water will also be released into the Kromspruit to re-join the water cycle and be available for downstream water use.

11(c) Emissions into the atmosphere

Will the activity release emissions into the atmosphere?

YES	NO
YES	NO

If yes, is it controlled by any legislation of any sphere of government?

If yes, the applicant should consult with the competent authority to determine whether it is necessary to change to an application for scoping and EIA.

If no, describe the emissions in terms of type and concentration:

--

11(d) Generation of noise

“Innovation for Sustainable Development”



Will the activity generate noise?

YES	NO
-----	----

If yes, is it controlled by any legislation of any sphere of government?

YES	NO
-----	----

If yes, the applicant should consult with the competent authority to determine whether it is necessary to change to an application for scoping and EIA.

If no, describe the noise in terms of type and level:

During the construction phase of the WWTW and bulk connector systems, earth moving equipment will be involved which will produce a substantial level of noise. However, construction will only occur during daylight hours and are unlikely to have a high impact on the residential area. The site is also located within an urban area where noise pollution is already prominent and will therefore not cause noise pollution within a quiet area.

During the operation phase the WWTW will produce a certain amount of noise although this is not anticipated to be high. The pumps, reactors and secondary sedimentation tanks will produce a low amount of noise due to mechanical working.

12. WATER USE

Please indicate the source(s) of water that will be used for the activity by ticking the appropriate box(es)

<input type="checkbox"/> municipal	<input type="checkbox"/> water board	<input type="checkbox"/> groundwater	<input type="checkbox"/> river, stream, dam or lake	<input type="checkbox"/> other	<input type="checkbox"/> the activity will not use water
------------------------------------	--------------------------------------	--------------------------------------	--	--------------------------------	---

If water is to be extracted from groundwater, river, stream, dam, lake or any other natural feature, please indicate

the volume that will be extracted per month:

litres

Does the activity require a water use permit from the Department of Water Affairs?

YES	NO
-----	----

"Innovation for Sustainable Development"



If yes, please submit the necessary application to the Department of Water Affairs and attach proof thereof to this application if it has been submitted.

Note: Once the WWTW is expanded to a 6 Ml capacity the oxidation ponds will not be sufficient to handle the anticipated treated discharge and as a result a portion of the treated discharge will be discharged via river outfall. A water use license will be required for this. A Water Use License has already been issued by DWS for this project and is included in Appendix G.

13. ENERGY EFFICIENCY

Describe the design measures, if any, that have been taken to ensure that the activity is energy efficient:

The infrastructure and technology to be used at the WWTW is state of the art and will be much more energy efficient than older technologies.

Describe how alternative energy sources have been taken into account or been built into the design of the activity, if any:

At this time no alternative energy sources have been incorporated into the WWTW.

SECTION B: SITE/AREA/PROPERTY DESCRIPTION

Important notes:

1. For linear activities (pipelines, etc) as well as activities that cover very large sites, it may be necessary to complete this section for each part of the site that has a significantly different environment. In such cases please complete copies of Section C and indicate the area, which is covered by each copy No. on the Site Plan.

“Innovation for Sustainable Development”



Section C Copy No. (e.g. A):

2. Paragraphs 1 - 6 below must be completed for each alternative.

3. Has a specialist been consulted to assist with the completion of this section?

YES	NO
-----	----

If YES, please complete form XX for each specialist thus appointed:

All specialist reports must be contained in Appendix D.

1. GRADIENT OF THE SITE

Note: The Sterkspruit region is highly mountainous and therefore the gradient differs over the area where the WWTW and associated bulk connector pipelines is situated.

Indicate the general gradient of the site.

Alternative S1:

Flat	1:50 – 1:20	1:20 – 1:15	1:15 – 1:10	1:10 – 1:7,5	1:7,5 – 1:5	Steeper than 1:5
------	-------------	-------------	-------------	--------------	-------------	------------------

Alternative S2 (if any):

Flat	1:50 – 1:20	1:20 – 1:15	1:15 – 1:10	1:10 – 1:7,5	1:7,5 – 1:5	Steeper than 1:5
------	-------------	-------------	-------------	--------------	-------------	------------------

Alternative S3 (if any):

Flat	1:50 – 1:20	1:20 – 1:15	1:15 – 1:10	1:10 – 1:7,5	1:7,5 – 1:5	Steeper than 1:5
------	-------------	-------------	-------------	--------------	-------------	------------------

2. LOCATION IN LANDSCAPE

Indicate the landform(s) that best describes the site:

2.1 Ridgeline

2.2 Plateau

“Innovation for Sustainable Development”



- 2.3 Side slope of hill/mountain
- 2.4 Closed valley
- 2.5 Open valley
- 2.6 Plain
- 2.7 Undulating plain / low hills
- 2.8 Dune
- 2.9 Seafront

3. GROUNDWATER, SOIL AND GEOLOGICAL STABILITY OF THE SITE

Is the site(s) located on any of the following (tick the appropriate boxes)?

	Alternative S1:		Alternative S2 (if any):		Alternative S3 (if any):	
Shallow water table (less than 1.5m deep)	YES	NO	YES	NO	YES	NO
Dolomite, sinkhole or doline areas	YES	NO	YES	NO	YES	NO
Seasonally wet soils (often close to water bodies)	YES	NO	YES	NO	YES	NO
Unstable rocky slopes or steep slopes with loose soil	YES	NO	YES	NO	YES	NO
Dispersive soils (soils that dissolve in water)	YES	NO	YES	NO	YES	NO
Soils with high clay content (clay fraction more than 40%)	YES	NO	YES	NO	YES	NO

“Innovation for Sustainable Development”



Any other unstable soil or geological feature

YES	NO

YES	NO

YES	NO

An area sensitive to erosion

YES	NO

YES	NO

YES	NO

If you are unsure about any of the above or if you are concerned that any of the above aspects may be an issue of concern in the application, an appropriate specialist should be appointed to assist in the completion of this section. (Information in respect of the above will often be available as part of the project information or at the planning sections of local authorities. Where it exists, the 1:50 000 scale Regional Geotechnical Maps prepared by the Council for Geo Science may also be consulted).

4. GROUNDCOVER

Indicate the types of groundcover present on the site:

- 4.1 Natural veld – good condition ^E
- 4.2 Natural veld – scattered aliens ^E
- 4.3 Natural veld with heavy alien infestation ^E
- 4.4 Veld dominated by alien species ^E
- 4.5 Gardens
- 4.6 Sport field
- 4.7 Cultivated land
- 4.8 Paved surface
- 4.9 Building or other structure
- 4.10 Bare soil

The location of all identified rare or endangered species or other elements should be accurately indicated on the site plan(s).

“Innovation for Sustainable Development”



Natural veld - good condition ^E	Natural veld with scattered aliens ^E	Natural veld with heavy alien infestation ^E	Veld dominated by alien species ^E	Gardens
Sport field	Cultivated land	Paved surface	Building or other structure	Bare soil

If any of the boxes marked with an “E” is ticked, please consult an appropriate specialist to assist in the completion of this section if the environmental assessment practitioner doesn’t have the necessary expertise.

5. LAND USE CHARACTER OF SURROUNDING AREA

Indicate land uses and/or prominent features that currently occur within a 500m radius of the site and give description of how this influences the application or may be impacted upon by the application:

- 5.1 Natural area
- 5.2 Low density residential
- 5.3 Medium density residential
- 5.4 High density residential
- 5.5 Informal residential
- 5.6 Retail commercial & warehousing
- 5.7 Light industrial
- 5.8 Medium industrial^{AN}
- 5.9 Heavy industrial^{AN}
- 5.10 Power station
- 5.11 Office/consulting room
- 5.12 Military or police base/station/compound
- 5.13 Spoil heap or slimes dam^A
- 5.14 Quarry, sand or borrow pit
- 5.15 Dam or reservoir
- 5.16 Hospital/medical centre
- 5.17 School
- 5.18 Tertiary education facility
- 5.19 Church
- 5.20 Old age home

“Innovation for Sustainable Development”



- 5.21 Sewage treatment plant^A
- 5.22 Train station or shunting yard^N
- 5.23 Railway line^N
- 5.24 Major road (4 lanes or more)^N
- 5.25 Airport^N
- 5.26 Harbour
- 5.27 Sport facilities
- 5.28 Golf course
- 5.29 Polo fields
- 5.30 Filling station^H
- 5.31 Landfill or waste treatment site
- 5.32 Plantation
- 5.33 Agriculture
- 5.34 River, stream or wetland
- 5.35 Nature conservation area
- 5.36 Mountain, koppie or ridge
- 5.37 Museum
- 5.38 Historical building
- 5.39 Protected Area
- 5.40 Graveyard
- 5.41 Archaeological site
- 5.42 Other land uses (describe)

If any of the boxes marked with an ^N "are ticked, how will this impact / be impacted upon by the proposed activity.

If any of the boxes marked with an ^{An} are ticked, how will this impact / be impacted upon by the proposed activity.

If YES, specify and explain:

If YES, specify:



"Innovation for Sustainable Development"



If any of the boxes marked with an "H" are ticked, how will this impact / be impacted upon by the proposed activity.

If YES, specify and explain:

If YES, specify:

|

|

"Innovation for Sustainable Development"



6. CULTURAL/HISTORICAL FEATURES

Are there any signs of culturally or historically significant elements, as defined in section 2 of the National Heritage Resources Act, 1999, (Act No. 25 of 1999), including Archaeological or palaeontological sites, on or close (within 20m) to the site?

YES	NO
No	

If YES, explain:

YES,	
------	--

If uncertain, conduct a specialist investigation by a recognised specialist in the field to establish whether there is such a feature(s) present on or close to the site.

Briefly explain the findings of the specialist:

No evidence of <i>in situ</i> Stone Age archaeological material, capped or distributed as surface scatters on the landscape. There are also no indications of rock art, prehistoric structures or historical buildings older than 60 years within the vicinity of the study area. It is unlikely that the proposed development will result in any significant archaeological impact along the demarcated footprints. The proposed pipeline routes are regarded as of low archaeological significance.
The palaeontological significance of the sedimentary bedrock at Sterkspruit is considered high and the nature of the proposed development suggests possible impact on potentially fossil-bearing Stormberg Group strata. An investigation of alluvial deposits of the Kromspruit and associated tributaries indicates that impact on potential palaeontological heritage resources within the overlying Quaternary soils is unlikely. The palaeontological significance of the unconsolidated Quaternary soils is therefore considered as low.

Will any building or structure older than 60 years be affected in any way?
Is it necessary to apply for a permit in terms of the National Heritage Resources Act, 1999 (Act 25 of 1999)?

YES	NO
YES	NO

If yes, please submit or, make sure that the applicant or a specialist submits the necessary application to SAHRA or the relevant provincial heritage agency and attach proof thereof to this application if such application has been made.

“Innovation for Sustainable Development”



SECTION C: PUBLIC PARTICIPATION

1. ADVERTISEMENT

The person conducting a public participation process must take into account any guidelines applicable to public participation as contemplated in section 24J of the Act and must give notice to all potential interested and affected parties of the application which is subjected to public participation by—

- (a) fixing a notice board (of a size at least 60cm by 42cm; and must display the required information in lettering and in a format as may be determined by the competent authority) at a place conspicuous to the public at the boundary or on the fence of—
 - (i) the site where the activity to which the application relates is or is to be undertaken; and
 - (ii) any alternative site mentioned in the application;
- (b) giving written notice to—
 - (i) the owner or person in control of that land if the applicant is not the owner or person in control of the land;
 - (ii) the occupiers of the site where the activity is or is to be undertaken or to any alternative site where the activity is to be undertaken;
 - (iii) owners and occupiers of land adjacent to the site where the activity is or is to be undertaken or to any alternative site where the activity is to be undertaken;
 - (iv) the municipal councillor of the ward in which the site or alternative site is situated and any organisation of ratepayers that represent the community in the area;
 - (v) the municipality which has jurisdiction in the area;
 - (vi) any organ of state having jurisdiction in respect of any aspect of the activity; and
 - (vii) any other party as required by the competent authority;
- (c) placing an advertisement in—
 - (i) one local newspaper; or
 - (ii) any official *Gazette* that is published specifically for the purpose of providing public notice of applications or other submissions made in terms of these Regulations;
- (d) placing an advertisement in at least one provincial newspaper or national newspaper, if the activity has or may have an impact that extends beyond the boundaries of the metropolitan or local municipality in which it is or will be undertaken: Provided that this paragraph need not be complied with if an advertisement has been placed in an official *Gazette* referred to in subregulation 54(c)(ii); and

“Innovation for Sustainable Development”



- (e) using reasonable alternative methods, as agreed to by the competent authority, in those instances where a person is desiring of but unable to participate in the process due to—
- (i) illiteracy;
 - (ii) disability; or
 - (iii) any other disadvantage.

2. CONTENT OF ADVERTISEMENTS AND NOTICES

A notice board, advertisement or notices must:

- (a) indicate the details of the application which is subjected to public participation; and
- (b) state—
 - (i) that the application has been submitted to the competent authority in terms of these Regulations, as the case may be;
 - (ii) whether basic assessment or scoping procedures are being applied to the application, in the case of an application for environmental authorisation;
 - (iii) the nature and location of the activity to which the application relates;
 - (iv) where further information on the application or activity can be obtained; and
 - (iv) the manner in which and the person to whom representations in respect of the application may be made.

3. PLACEMENT OF ADVERTISEMENTS AND NOTICES

Where the proposed activity may have impacts that extend beyond the municipal area where it is located, a notice must be placed in at least one provincial newspaper or national newspaper, indicating that an application will be submitted to the competent authority in terms of these regulations, the nature and location of the activity, where further information on the proposed activity can be obtained and the manner in which representations in respect of the application can be made, unless a notice has been placed in any *Gazette* that is published specifically for the purpose of providing notice to the public of applications made in terms of the EIA regulations.

Advertisements and notices must make provision for all alternatives.

“Innovation for Sustainable Development”



4. DETERMINATION OF APPROPRIATE MEASURES

The practitioner must ensure that the public participation is adequate and must determine whether a public meeting or any other additional measure is appropriate or not based on the particular nature of each case. Special attention should be given to the involvement of local community structures such as Ward Committees, ratepayers associations and traditional authorities where appropriate. Please note that public concerns that emerge at a later stage that should have been addressed may cause the competent authority to withdraw any authorisation it may have issued if it becomes apparent that the public participation process was inadequate.

5. COMMENTS AND RESPONSE REPORT

The practitioner must record all comments and respond to each comment of the public before the application is submitted. The comments and responses must be captured in a comments and response report as prescribed in the EIA regulations and be attached to this application. The comments and response report must be attached under Appendix E.

6. AUTHORITY PARTICIPATION

Authorities are key interested and affected parties in each application and no decision on any application will be made before the relevant local authority is provided with the opportunity to give input. The planning and the environmental sections of the local authority must be informed of the application at least 30 (thirty) calendar days before the submission of the application.

List of authorities informed:

Municipal Manager: Senqu Local Municipality
Municipal Ward Councillor (Ward 8): Senqu Local Municipality
Municipal Ward Councillor (Ward 10): Senqu Local Municipality
Municipal Ward Councillor (Ward 11): Senqu Local Municipality
Department of Water Affairs and Sanitation (DWS)
Eastern Cape Provincial Heritage Resources Authority (ECPHRA)
South African Heritage Resource Agency (SAHRA)
Municipal Manager: Joe Gqabi District Municipality

List of authorities from whom comments have been received:

“Innovation for Sustainable Development”



None to date

“Innovation for Sustainable Development”



7. CONSULTATION WITH OTHER STAKEHOLDERS

Note that, for linear activities, or where deviation from the public participation requirements may be appropriate, the person conducting the public participation process may deviate from the requirements of that subregulation to the extent and in the manner as may be agreed to by the competent authority.

Any stakeholder that has a direct interest in the site or property, such as servitude holders and service providers, should be informed of the application at least 30 (thirty) calendar days before the submission of the application and be provided with the opportunity to comment.

Has any comment been received from stakeholders?

YES NO

If "YES", briefly describe the feedback below (also attach copies of any correspondence to and from the stakeholders to this application):



SECTION D: IMPACT ASSESSMENT

The assessment of impacts must adhere to the minimum requirements in the EIA Regulations, 2014 as amended, and should take applicable official guidelines into account. The issues raised by interested and affected parties should also be addressed in the assessment of impacts.

1. ISSUES RAISED BY INTERESTED AND AFFECTED PARTIES

List the main issues raised by interested and affected parties.

None

It must be noted that this project already had environmental authorization which had expired.

Response from the practitioner to the issues raised by the interested and affected parties (A full response must be given in the Comments and Response Report that must be attached to this report):

None

2. IMPACTS THAT MAY RESULT FROM THE PLANNING AND DESIGN, CONSTRUCTION, OPERATIONAL, DECOMMISSIONING AND CLOSURE PHASES AS WELL AS PROPOSED MANAGEMENT OF IDENTIFIED IMPACTS AND PROPOSED MITIGATION MEASURES

List the potential direct, indirect and cumulative property/activity/design/technology/operational alternative related impacts (as appropriate) that are likely to occur as a result of the planning and design phase, construction phase, operational phase, decommissioning and closure phase, including impacts relating to the choice of site/activity/technology alternatives as well as the mitigation measures that may eliminate or reduce the potential impacts listed.

Alternative (preferred alternative)

<u>Potential Impacts:</u>	<u>Recommended mitigation measures:</u>
<i>Planning and Design Phase</i>	<i>Planning and Design Phase</i>
<i>Direct impacts: None</i>	No impacts expected

"Innovation for Sustainable Development"



<p><i>Indirect impacts:</i> None</p> <p><i>Cumulative impacts:</i> None</p> <p><i>Construction Phase</i></p> <p><i>Direct impacts:</i></p> <ul style="list-style-type: none"> • Removal of topsoil and potential loss thereof. • Destruction of habitat for small animals. • Removal of the vegetation layer on the site. • Noise elevation due to construction activities. • Nuisance dust generation. • Possible damage to palaeontological heritage during excavation activities. • Injuries to humans entering the site unnoticed. <p><i>Indirect impacts:</i></p> <ul style="list-style-type: none"> • Potential erosion of the exposed soil. • Possible dumping of construction rubble and general waste on the site. • Possible spillage of products like paint, oil, cleaning agents, etc. which may lead to water and/or soil contamination. • Possible spillage of untreated sewage to the surrounding environment. <p><i>Cumulative impacts:</i></p>	<p><i>Construction Phase</i></p> <p><i>Mitigation Measures:</i></p> <ul style="list-style-type: none"> • The surface of the site will be levelled to ensure a free-draining surface to prevent ponding of surface water as well as to limit erosion. • During construction, storm water measures such as channels, diversion berms, etc. will be constructed around the construction site in order to limit and/or prevent erosion and separate clean and dirty runoff. • Topsoil removed will be kept separate and reused. • As stated in this report the condition of the site is highly degraded and transformed and the impact on the vegetation would therefore be minimal. • The site is highly disturbed and transformed and it is therefore anticipated that the impact on small mammals on the site will be minimal. • No harming, hunting, capturing or trapping of animals on the site may occur. • A speed limit will be enforced on the construction vehicles. • Construction activities will be limited to daytime to limit any disturbance to neighbouring landowners. • The nearest residences are located 500 meters from the site and is therefore unlikely to be affected by noise caused by construction • Dust control measurements will be investigated if nuisance dust generation during construction proofs to be problematic. • SAHRA will be notified should traces of any palaeontological heritage be found during construction. • Adequate fencing must be erected around the site. • Warning signs must be attached to fencing and at the entrance of the construction site. • The pipeline construction areas must be clearly marked off.
--	---

“Innovation for Sustainable Development”



<p>lagoons into groundwater and the surrounding Kromspruit.</p> <ul style="list-style-type: none"> Increased flows in the Kromspruit due to discharge from the works can cause erosion of the bed and banks and an increase in sediment to the downstream reaches. <p><i>Cumulative impacts:</i> None</p>	<ul style="list-style-type: none"> The design of the WWTW reticulation system should be such to ensure competent operation and separated from the consumable water system. Conduct regular inspections of infrastructure at intervals so as to identify any potential failure of infrastructure and repair immediately. Develop a contingency plan for periods of load shedding that will prevent the release of raw sewage into the Kromspruit. Adopt proper engineering codes and implement a storm water management plan. The design of oxidation ponds should incorporate free-board volumes which should compensate for most storm events. Ensure that adequately lined drainage is in place around the outside of the ponds to ensure that any overflow is diverted back to the head of the WWTW. Stormwater diversion berms should be incorporated into the site design. Regular site inspection and critical observation of the ponds is recommended to ensure that possible leaks are identified and that environmental conditions have not impacted on the operation of the WWTW. On-site operating staff MUST be trained and certified by the relevant authorities. The sewage pipes must be tested for defects and leaks before the trenches are closed. Technically appropriate and SABS approved sewer material must be used. In order to limit erosion measures such as gabions and velocity dissipaters must be established at the outflow point. Construction of the chlorine handling facilities must comply with the latest legal, environmental and health bylaws.
--	--

“Innovation for Sustainable Development”



<p><i>Decommissioning and Closure Phase</i></p> <p><i>Direct impacts:</i></p> <ul style="list-style-type: none"> No Decommissioning Phase is foreseen for the proposed project which will have a lifetime of 30 - 40 years. <p><i>Indirect impacts:</i> None</p> <p><i>Cumulative impacts</i> None</p>	<ul style="list-style-type: none"> Activated sludge treatment systems produce a highly treated and well-nitrified effluent that typically meets the required effluent quality standards. However, to ensure that acceptable standards are kept the effluent being discharged will be tested at regular intervals. <p><i>Decommissioning and Closure Phase</i></p> <p><i>Direct impacts:</i></p> <ul style="list-style-type: none"> Should the WWTW be decommissioned in future a Rehabilitation Plan dependant on the end land use will be developed and be submitted to the Department for approval. It is important to note that the decommissioning of a WWTW is currently a listed activity in terms of NEMA (Act 107 of 1998). If the facility is therefore decommissioned in future the applicant would have to apply for Environmental Authorisation. This must be verified at the time of decommissioning should it occur. <p><i>Indirect impacts:</i> None</p> <p><i>Cumulative impacts</i> None</p>
<p><u>Alternative 2 (Oxidation Ponds)</u></p>	
<p>Potential Impacts:</p>	<p>Recommended mitigation measures:</p>

“Innovation for Sustainable Development”



<p><u>Planning and Design Phase</u></p> <p>Direct impacts: None</p> <p>Indirect impacts: None</p> <p>Cumulative impacts: None</p> <p><u>Construction Phase</u></p> <p>Direct impacts:</p> <ul style="list-style-type: none"> • Removal of topsoil and potential loss thereof. • Destruction of habitat for small animals. • Removal of the vegetation layer on the site. • Noise elevation due to construction activities. • Nuisance dust generation. • Possible damage to palaeontological heritage during excavation activities. • Injuries to humans entering the site unnoticed. 	<p><u>Planning and Design Phase</u></p> <p>No impacts expected</p> <p><u>Construction Phase</u></p> <p>Mitigation Measures:</p> <ul style="list-style-type: none"> • The surface of the site will be levelled to ensure a free-draining surface to prevent ponding of surface water as well as to limit erosion. • During construction, storm water measures such as channels, diversion berms, etc. will be constructed around the construction site in order to limit and/or prevent erosion and separate clean and dirty runoff. • Topsoil removed will be kept separate and reused. • The oxidation pond system will require a very large area to be transformed and it is therefore anticipated that the impact on the vegetation will be exceedingly higher. • Due to the large area required for the oxidation ponds it is anticipated that there will be an impact on the animals in the area. • No harming, hunting, capturing or trapping of animals on the site may occur. • A speed limit will be enforced on the construction vehicles. • Construction activities will be limited to daytime to limit any disturbance to neighbouring landowners. • The nearest residences are located 500 meters from the site and is therefore unlikely to be affected by noise caused by construction
--	--

“Innovation for Sustainable Development”



<p><u>Operational Phase</u> Direct impacts:</p>	<ul style="list-style-type: none"> • Dust control measurements will be investigated if nuisance dust generation during construction proves to be problematic. • SAHRA will be notified should traces of any palaeontological heritage be found during construction. • Adequate fencing must be erected around the site. • Warning signs must be attached to fencing and at the entrance of the construction site. • The pipeline construction areas must be clearly marked off. • Excavations for the pipelines must be closed as quickly as possible to decrease the likelihood of accidents. • Measures must be implemented to ensure that pipeline excavations are safe to the general public. This is especially relevant to night times when excavations are not easily visible. • No construction and / or any other waste may be dumped in the veld. • All spills should be cleaned immediately • All building rubble will be removed by the contractor on a regular basis and disposed of at an authorised landfill site in Sterkspruit or used as filling material during construction. • Receptacles should be placed on site for the collection of general waste. These receptacles should be emptied on a regular basis and waste be disposed of at the authorised landfill site in the region. • Temporary toilets should be placed on site for use by construction workers. Sewage from these toilets should be managed appropriately and not be disposed of on site or the surrounding environment. <p><u>Operational Phase</u> Mitigation Measures:</p>
---	---

“Innovation for Sustainable Development”



<ul style="list-style-type: none"> • Littering on the WWTW site during operation. • Increased odour levels at the new WWTW. • Discharged treated water may not meet DWS minimum standards. <p>Indirect impacts:</p> <ul style="list-style-type: none"> • Pollution due to spillage or seepage of sewage and sludge from the lagoons into groundwater and the surrounding Kromspruit. <p>Cumulative impacts: None</p>	<ul style="list-style-type: none"> • Ample refuse bins must be placed on the site. These will be emptied regularly and disposed of at the local landfill site. • Due to the large area required for the oxidation ponds it is anticipated that the odour impact will be considerably higher. • Odour control must be adequately provided for in the design and specification of the new WWTW. • Maintenance of the WWTW should be continued to ensure an optimal working area. • The design of the WWTW reticulation system should be such to ensure competent operation and separated from the consumable water system. • Conduct regular inspections of infrastructure at intervals so as to identify any potential failure of infrastructure and repair immediately. • Develop a contingency plan for periods of load shedding that will prevent the release of raw sewage into the Kromspruit. • Adopt proper engineering codes and implement a storm water management plan. • The design of oxidation ponds should incorporate free-board volumes which should compensate for most storm events. • Ensure that adequately lined drainage is in place around the outside of the ponds to ensure that any overflow is diverted back to the head of the WWTW. • Stormwater diversion berms should be incorporated into the site design. • Regular site inspection and critical observation of the ponds is recommended to ensure that possible leaks are identified and that environmental conditions have not impacted on the operation of the WWTW. • On-site operating staff MUST be trained and certified by the relevant authorities.
--	--

“Innovation for Sustainable Development”



<p><u>Decommissioning and Closure Phase</u></p> <p>Direct impacts:</p> <ul style="list-style-type: none"> No Decommissioning Phase is foreseen for the proposed project which will have a lifetime of 30 - 40 years. <p>Indirect impacts: None</p> <p>Cumulative impacts: None</p>	<ul style="list-style-type: none"> The sewage pipes must be tested for defects and leaks before the trenches are closed. Technically appropriate and SABS approved sewer material must be used. The oxidation pond system cannot be discharged into the Kromspruit due to unacceptable water quality standards and treated water will have to irrigated. <p><u>Decommissioning and Closure Phase</u></p> <p>Direct impacts:</p> <ul style="list-style-type: none"> Should the WWTW be decommissioned in future a Rehabilitation Plan dependant on the end land use will be developed and be submitted to the Department for approval. It is important to note that the decommissioning of a WWTW is currently a listed activity in terms of NEMA (Act 107 of 1998). If the facility is therefore decommissioned in future the applicant would have to apply for Environmental Authorisation. This must be verified at the time of decommissioning. <p>Indirect impacts: None</p> <p>Cumulative impacts: None</p>
---	---



Taking the assessment of potential impacts into account, please provide an environmental impact statement that summarises the impact that the proposed activity and its alternatives may have on the environment after the management and mitigation of impacts have been taken into account, with specific reference to types of impact, duration of impacts, likelihood of potential impacts actually occurring and the significance of impacts.

The likelihood of significant expected impacts actually occurring is highly unlikely and limited if recommended mitigation measures are implemented throughout the phases of the project.

The proposed site is already transformed, highly degraded and cannot be considered to be of significant conservation value. The site which will be affected by the WWTW is already highly disturbed and the anticipated impacts caused by the construction will not cause a high disturbance of the site since it is already highly disturbed.

The site is subjected to numerous impacts which include the following. The area is subjected to heavy and sustained overgrazing which has led to significantly low vegetation cover which in turn leads to greater runoff, increased erosion and high sediment loads. The area contains a moderate density but expansive area of residential and light industrial development. This area is also highly affected by insufficient sewage systems and is highly affected by rubbish dumping and littering. As a result the runoff from these residential areas is highly polluted and has a high impact on the Kromspruit. These areas also lack surface cover in the form of vegetation or paving. As a result the area is subjected to high erosion, increased sediment loads and increased runoff which further negatively impacts on the Kromspruit. The existing WWTW has oxidation ponds where sewage is being pumped into. These ponds are inadequate and leaking and as a result highly polluted water enters the Kromspruit and causes high levels of pollution, algal blooms and consequently eutrofication of the river. The Kromspruit is also subjected to several other impacts including bridge crossing of roads, abstraction for irrigation, polluted runoff from irrigated and dryland crop cultivation, rubbish dumping and excavation of material from the river.

It is anticipated that the establishment of the new WWTW will alleviate and improve the current conditions as the treated water will be of better quality and the oxidation ponds will be upgrading and re-constructed so that leakages into the Kromspruit no longer take place. Impacts that will be associated with the Construction Phase will be temporary in nature. Although the activities that will be associated with the Operational Phase will be permanent it should be clear from the above as well as the nature of the development that the potential impacts associated with this phase will be minimal and local in nature. The likelihood of

“Innovation for Sustainable Development”



potential impacts occurring during the operational phase is highly unlikely.

Alternative A (preferred alternative)

As stated above

Alternative 2 (oxidation ponds)

This alternative will entail the use of oxidation ponds exclusively for treatment of sewage and the WWTW will not be upgraded to an activated sludge system. The alternative will entail several other impacts which renders it unfeasible.

Firstly an oxidation pond WWTW will require a large surface area (Apprx. 15 ha) which is not present on the site and there is therefore not enough surface area to construct such a WWTW. The large surface area to be transformed will also have a much higher impact on the vegetation and fauna of the area.

This alternative will also entail oxidation pond treatment which has been proven to be much less effective than activated sludge treatment. The treated water will therefore have much higher levels of pollution after treatment. It will then not be possible to release the treated water back into the Kromspruit. The treated water will have to irrigated on cropfields or grazing. The area has been urbanised and does not contain any such areas in close proximity. It will therefore not be possible to irrigate the treated water.

Due to the above constraints it will not be possible to implement this alternative.

No-go alternative (compulsory)

The current WWTW has reached capacity and the infrastructure is no longer able to service the Sterkspruit area. The area does not contain any pipeline infrastructure and the small portion of existing pipeline is exceedingly dilapidated and is causing leakage of sewage into groundwater and surface water resources. The population of Stetrkspruit require adequate Waste Water Treatment Works and the capacity of the current WWTW must be enlarged. The no-go alternative would entail a higher environmental impact than the construction of the new WWTW. The current oxidation ponds and pipeline infrastructure is causing raw sewage to leak

“Innovation for Sustainable Development”



into the groundwater and surface water resources. The construction of the new WWTW and pipeline infrastructure will improve these impacts.



SECTION E. RECOMMENDATIONS OF PRACTITIONER

Is the information contained in this report and the documentation attached hereto sufficient to make a decision in respect of the activity applied for (in the view of the environmental assessment practitioner)?

YES	NO
YES	NO

Is an EMPr attached?

The EMPr must be attached as Appendix F.

If "NO", indicate the aspects that should be assessed further as part of a Scoping and EIA process before a decision can be made (list the aspects that require further assessment):

--

If "YES", please list any recommended conditions, including mitigation measures that should be considered for inclusion in any authorisation that may be granted by the competent authority in respect of the application:

In addition to the recommended mitigation and management measures the following conditions are recommended:

- Compliance with mitigation measures within the BAR, EMPr and all specialist reports.
- Strict monitoring must be maintained which must include:
 - It is recommended that regular monitoring of all the environmental management measures and components should be undertaken during the construction phase to verify compliance to the EMPr.
 - Ongoing and regular reporting of the progress of implementation of this EMPr will be done.
 - Visual inspections on physical pollution shall be carried out on a regular basis.
 - To ensure that acceptable standards are kept the effluent being discharged will be tested at regular intervals.
 - Monitoring must include points upstream and downstream within the Kromspruit from the WWTW to ascertain the impact and quality of discharge.
- Odour control must be adequately provided for in the design and specification of the new WWTW.
- Impacts on the Kromspruit must be kept to a minimum during construction and operation.

"Innovation for Sustainable Development"



- The design of the facility and operational procedures should be done in manner to ensure compliance to the general wastewater limits as defined in the revision of the General Authorisations in Terms of Section 39 of The National Water Act, 1998 (Act No. 36 Of 1998) of 6 September 2013.
- The irrigation of the final effluent can be considered an existing lawful use as this was practiced **before the promulgation of the National Water Act 1998.**
- The re-use of final effluent should also be maximized to support the national objectives to conserve natural resources.
- The storage and disposal of grid from the inlet works should be done according to best practices to prevent contamination of runoff and soil.
- The disposal of sludge should be done according to The Guideline for Permissible Utilisation and Disposal of Wastewater Sludge Volume 3: Requirements for the on-site and off-site disposal of sludge (2009).
- Public safety must take priority especially concerning the bulk pipelines and their installation within the residential areas.
- Topsoil removed will be kept separate and re-used.
- A speed limit will be enforced on the construction vehicles.
- Construction activities will be limited to daytime to limit any disturbance to neighbouring land owners.
- Dust control measures will be investigated if nuisance dust generation during construction proofs to be problematic.
- SAHRA will be notified should traces of any palaeontological heritage be found during construction.
- No construction and/or any other waste may be dumped in the veld.
- All spills will be cleaned immediately.
- All building rubble will be removed by the contractor on a regular basis and disposed of at an authorised landfill site in Sterkspruit or used as filling material during construction.
- Receptacles should be placed on the site for the collection of general waste. These receptacles should be emptied on a regular basis and waste disposed of at the authorised landfill site in the region.
- Temporary toilets should be placed on the site for use by construction workers. Sewage from these toilets should be managed appropriately and not disposed of on site or the surrounding environment.

It is anticipated that the development will entail a low impact significance as long as mitigation measures as listed within the BAR and EMPr are successfully implemented. No unacceptably high impacts are foreseen.

“Innovation for Sustainable Development”



All recommendations and mitigation measures as stipulated by the specialist reports as well as the EMPr must be adhered to.

“Innovation for Sustainable Development”



SECTION F: APPENDICES

The following appendixes must be attached as appropriate:

Appendix A: Site plan(s)

Appendix B: Photographs

Appendix C: Facility illustration(s)

Appendix D: Specialist reports

Appendix E: Comments and responses report

Appendix F: Environmental Management Programme (EMPr)

Appendix G: Other information



“Innovation for Sustainable Development”

1 Floor Room 274 • Beacon Hill • Hockley Close • Kind William’s Town • 5600 | Private Bag X0054 • 5605 • Republic of South Africa
Tel; 043 605 7099 • Fax: 043 605 7300 | Email: • Web: www.dedeat.gov.za

VERSION 1 dated 8 December 2014





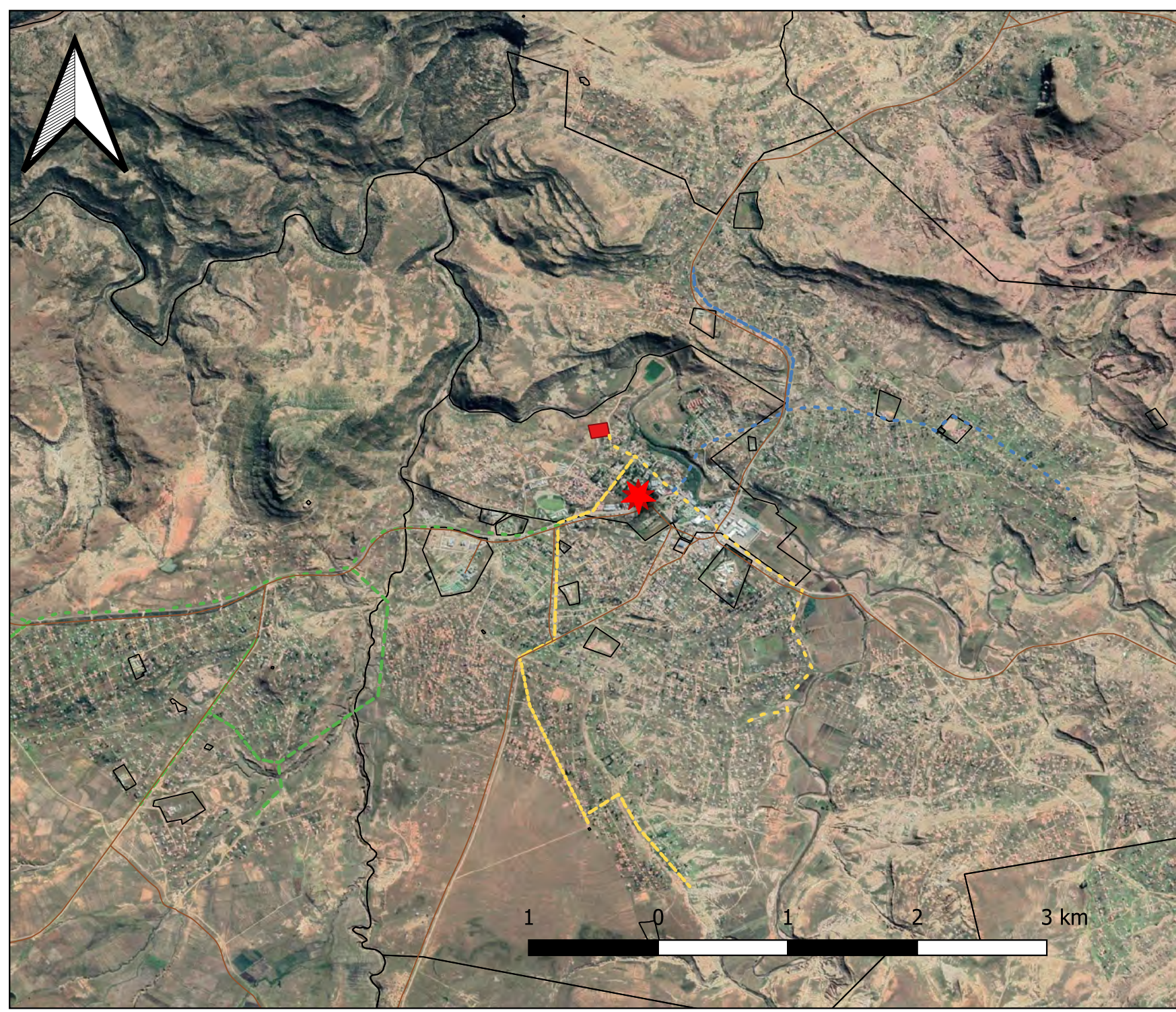

APPENDIX: **A**



Locality map



Legend

-  Sterkspruit
-  Roads Network
-  Phase 3
-  Phase 2
-  Phase 1
-  WWTW
-  Farm Portion

Map 1: Locality Map of the proposed Sterkspruit Regional WWTW and associated bulk infrastructure in Senqu Local Municipality, Eastern Cape Province. The site and pipelines are indicated as well as property boundaries and road network.

Prepared for: Dumamani Consulting CC

Map Information:
Projection: WGS 84
Scale: 1: 30 000

Site Coordinates:
30.518754° S
27.366651° E

Environmental Consultant:
Eko Environmental
Tel: 051 444 4700
E: info@ekogroup.co.za





Eastern Cape Biodiversity Conservation Plan (ECBCP) map for the proposed Waste Water Treatment Works (WWTW) and associated bulk infrastructure pipelines in the town of Sterkspruit, Eastern Cape Province.

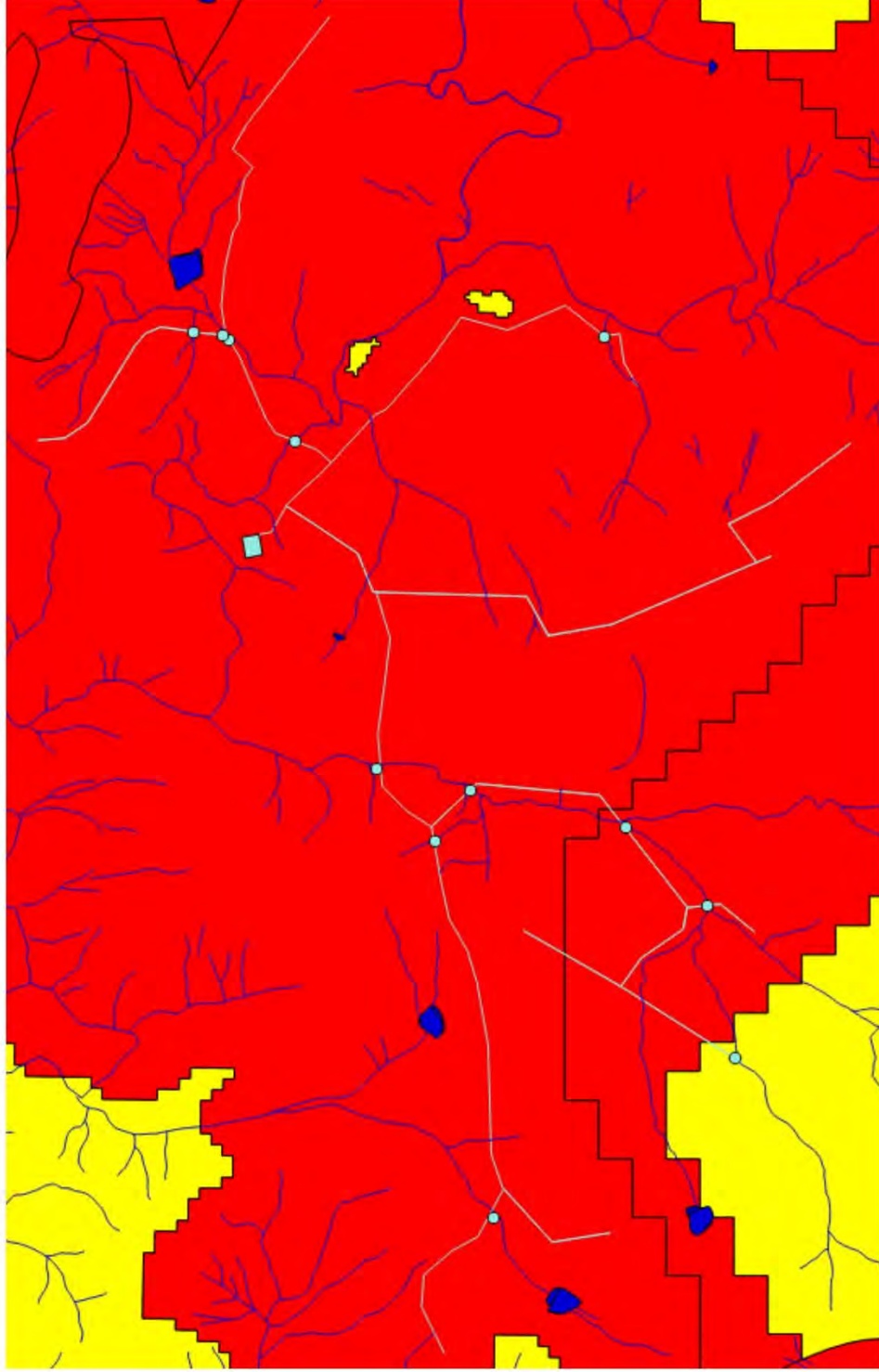

Map 3: ECBCP map of the proposed WWTW and bulk infrastructure pipeline in Sterkspruit. Note that the area is considered a Critical Biodiversity Area 1 (CBA 1) due to it being situated in the endangered Drakensberg-Maloti area. However, available data as well as the on-site surveys confirmed that natural vegetation within this area has almost completely been transformed.



Prepared for:
EKO Environmental
Suite 227, Private Bag X01
Brandhof
9324

Legend:

- Watercourses
- Pipeline route
- Points of crossing
- Wetlands and impoundments
- Critical Biodiversity Area 1
- Critical Biodiversity Area 2
- Critical Biodiversity Area 3

Map Information

Spheroid: WGS 84
Quantum GIS
Scale: 1:45 000

DPR Ecologists
Contact Darius van Rensburg at:
darius@dprecologists.co.za
P.O. Box 12726, Brandhof, 9324
Tel: 083 410 0770



APPENDIX B



Photographic Report



Figure 1: View of the site as seen toward the north. Note the existing oxidation ponds and the mountainous terrain in the background.



Figure 2: View of the Kromspruit adjacent to the WWTW.



Figure 3: View of the WWTW toward the south. The existing oxidation ponds are visible.



Figure 4: View of the WWTW toward the west. The existing oxidation ponds are visible.



Figure 5: View of the WWTW site looking toward the east.



Figure 6: View of the Phase 1 pipeline route along the eastern split section. The pipeline will be installed next to the road.



Figure 7: View of the Phase 1 pipeline route along the eastern split.



Figure 8: View of the Phase 1 pipeline along the western split. The pipeline will be installed adjacent to the road.



Figure 9: View of the Phase 1 pipeline along the western split. The pipeline will be installed adjacent to the road.



Figure 10: View of the Phase 2 pipeline along the eastern split. The pipeline will be installed adjacent to the road.



Figure 11: View of the Phase 2 pipeline along the eastern split. The pipeline will be installed adjacent to the road. The pipeline will cross the seasonal stream by means of a bridge attachment and the stream will therefore not be affected.



Figure 12: View of the Phase 2 pipeline along the western split. The pipeline will be installed adjacent to the road.

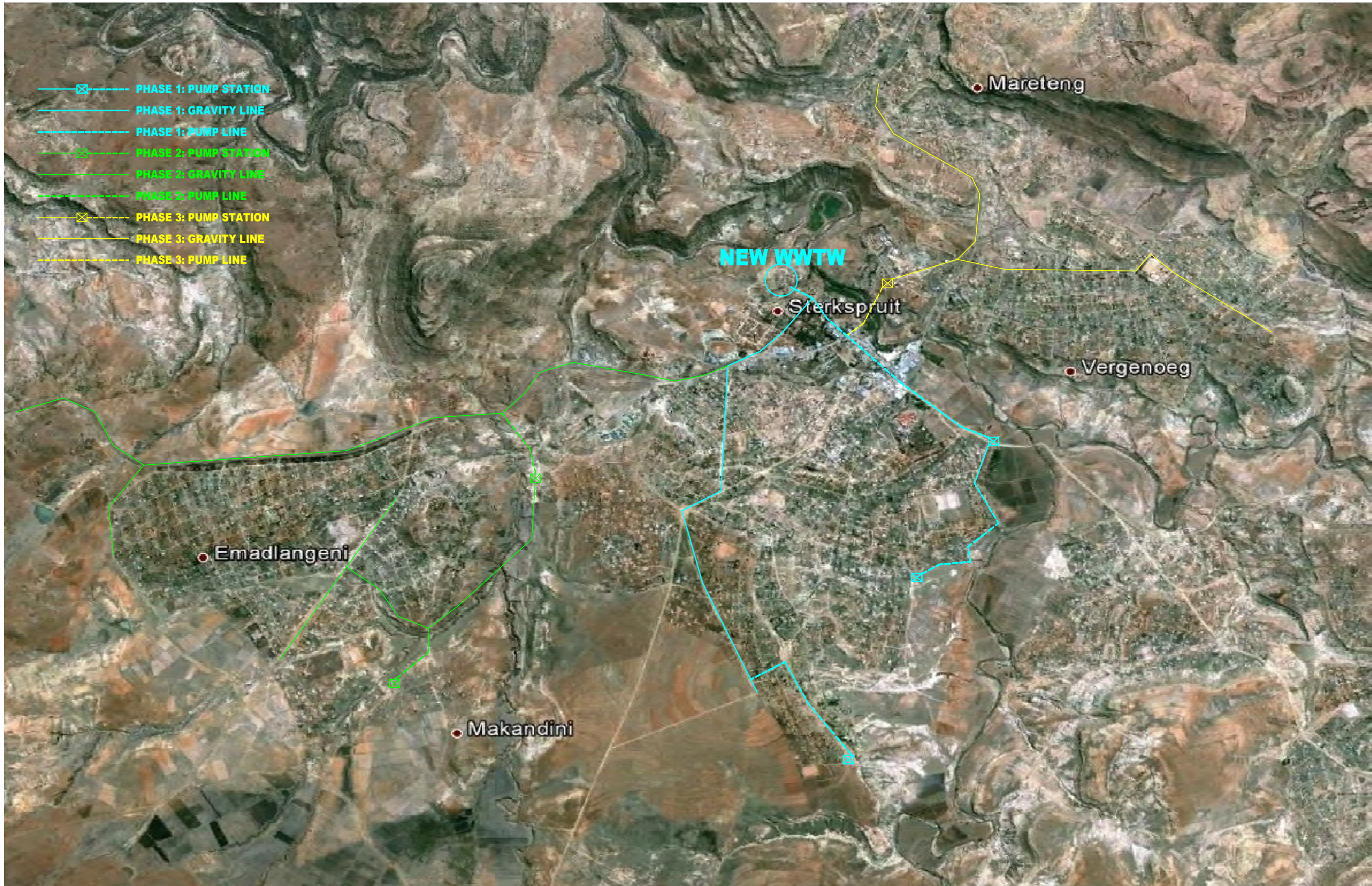

Figure 13: View of the Phase 2 pipeline along the western split. The pipeline will be installed adjacent to the road.

APPENDIX: C



Facility Illustration



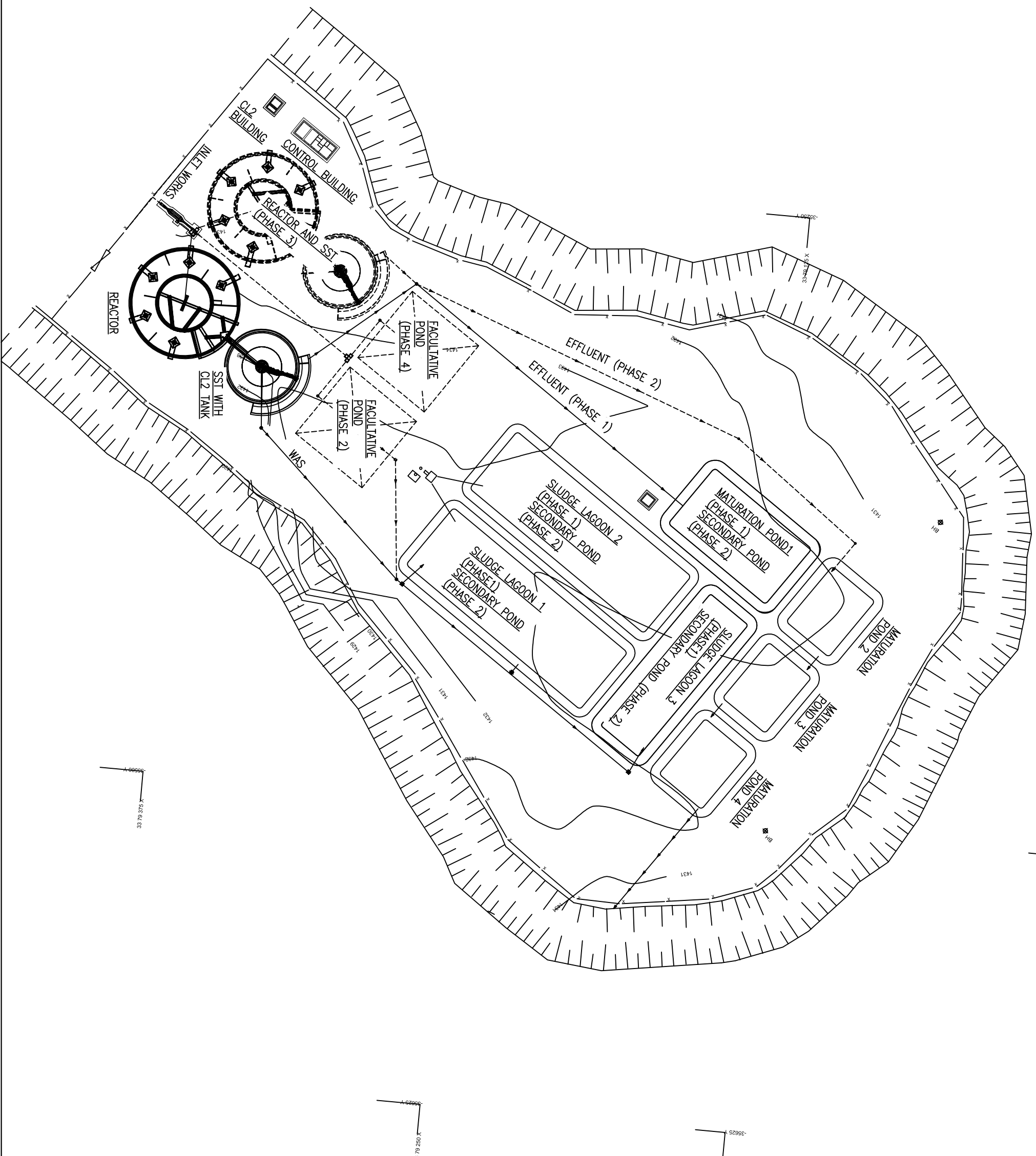
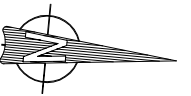

X 527 79 83

X 527 79 83

X 527 79 83

X 527 79 83

X 527 79 83

NOTES / NOTAS

The information contained in this drawing is patented in South Africa (ZA patent no. 2003/9329) and other countries (PCT Patent Application Ser. No. ZA04/00155) and is the sole property of Tecover (Pty) Ltd. Any reproduction thereof in part or whole without the written permission of Tecover (Pty) Ltd is prohibited in terms of the copyright act.



NO.	DATE	REVISION	BY	CHECKED



PROJECT MANAGERS

PROJECT RESTRICTIONS

CLIENT

CLIENT

PROJECT

STERKSPRUIT WWTP UPGRADE

TEKONINGNOMMER

DRAWING TITLE

SITE LAY OUT

HANDLING	DATE	BY	STATUS

TEKONINGNOMMER / DRAWING NUMBER

P2014/08/11 -- 0

WYSIGING / REVISION

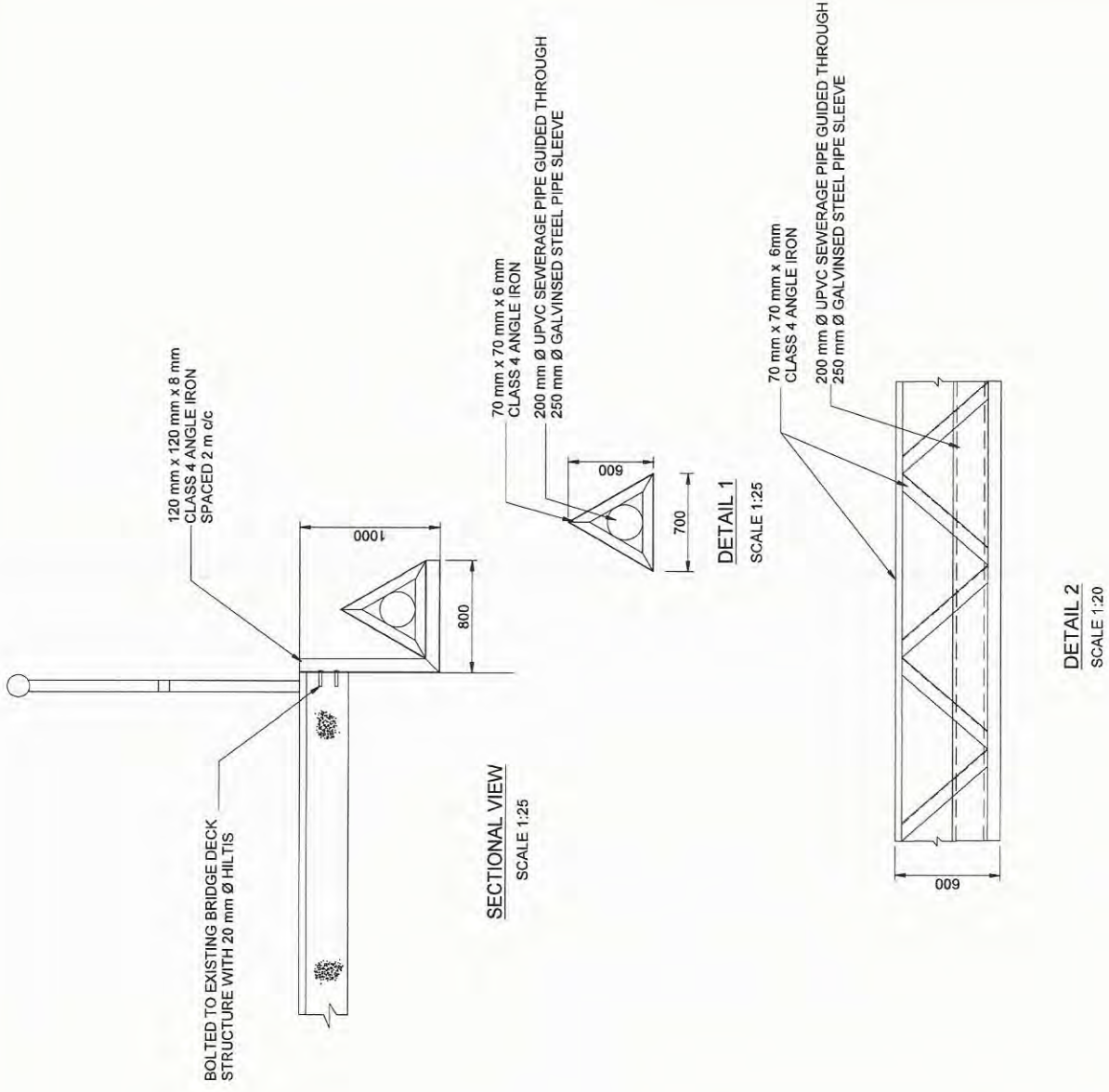
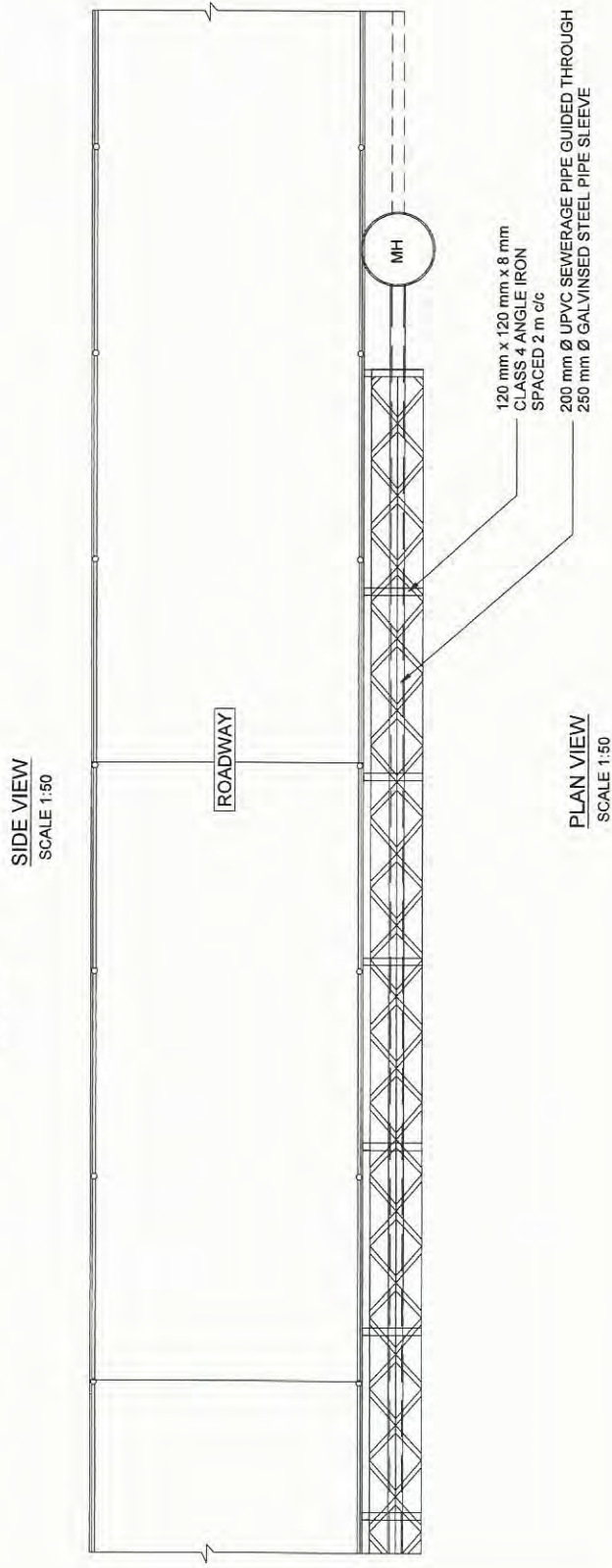
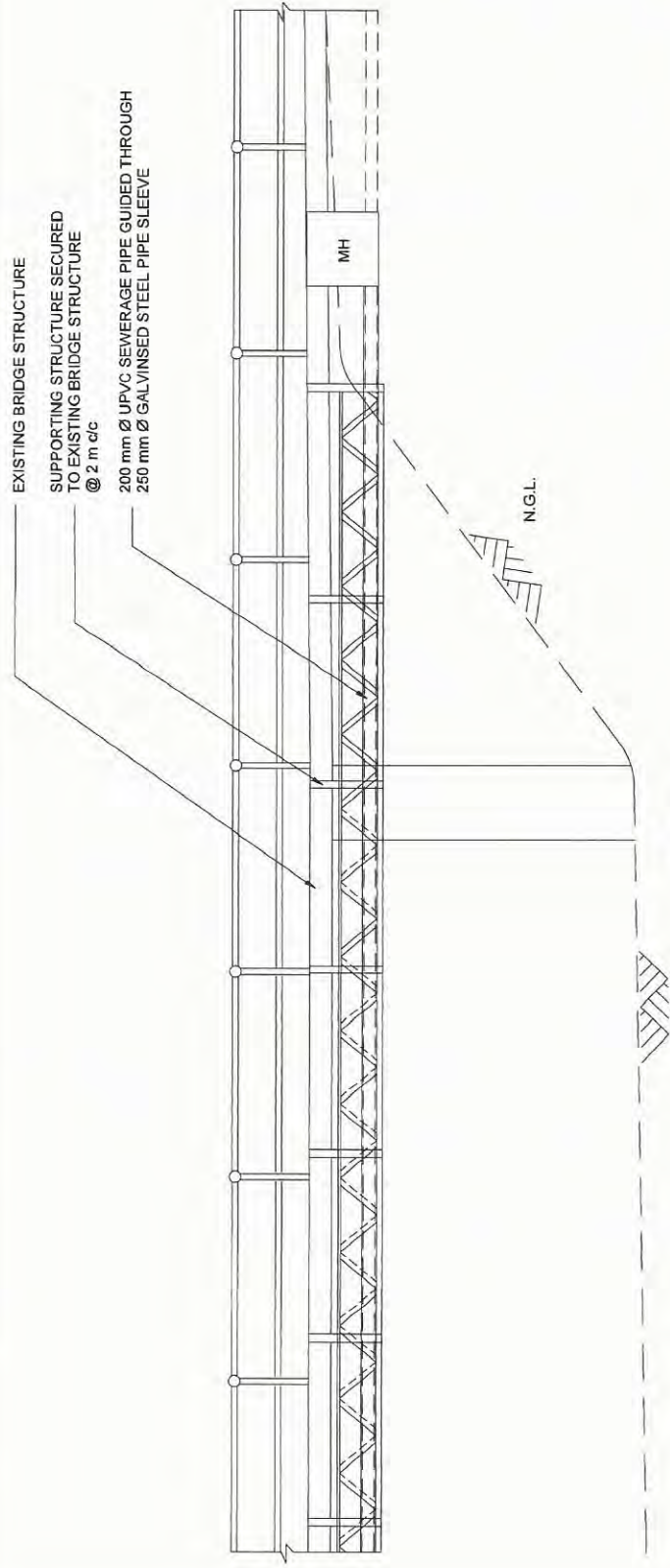

FIGURE 1 : BRIDGE CROSSING

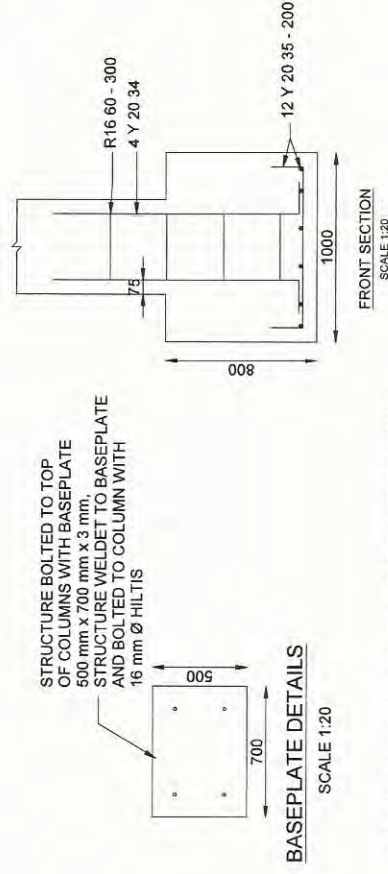
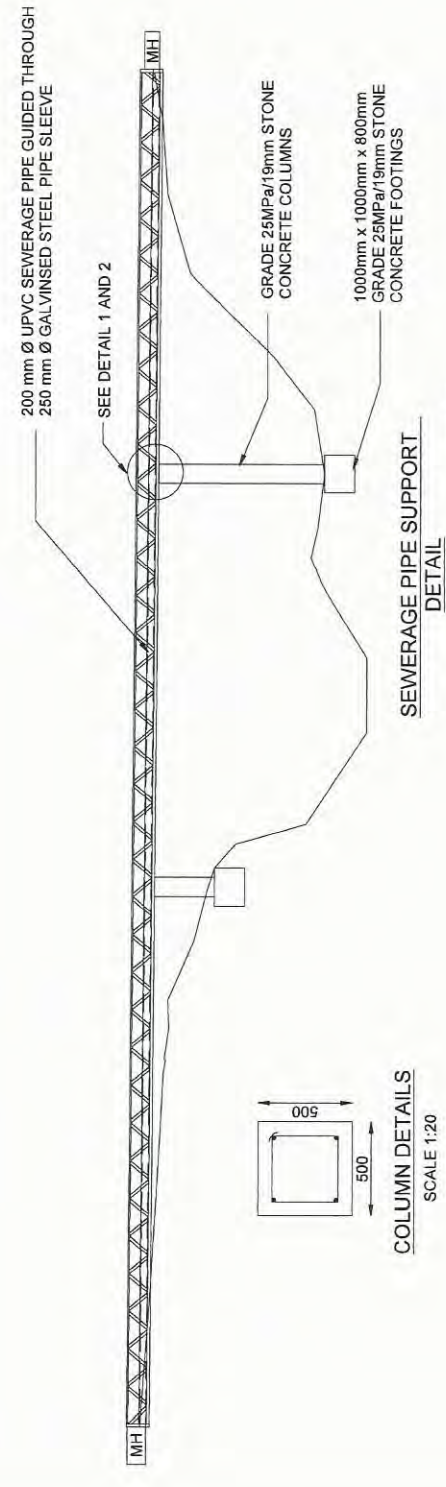

FIGURE 2 : STORMWATER DITCH CROSSING

Drawn	ES	Designed	FS	Signed	FS
Checked	FS	Engineer	FS	Date	
Client App.		Date	19 MAY 2015		
Drawing No		01 DIB 02 - 2015			

REPORT

DRAWING REFERENCE

NOTES

No

Date

Title

JOE GOQABI DISTRICT MUNICIPALITY
STERKSPRUIT BULK SEWERAGE
INFRASTRUCTURE (RBIG) PROJECT
PIPELINE CROSSING
DETAILS

P.O. Box 43335
HEILWELSIG
9332

Fax: 086 603 0220

E-mail: dibanani@vodamail.co.za



SPECIFICATIONS

- 1 - SLOPE OF EMBANKMENTS MUST BE 1 VERTICAL : 2.5 HORIZONTAL.
- 2 - ANY FILL DONE BENEATH STRUCTURE MUST BE IN LAYERS WITH MAXIMUM THICKNESS OF 150mm COMPACTED TO 98 % MODIFIED AASHTO DENSITY.
- 3 - STORM WATER BERM MUST BE FORMED AROUND STRUCTURE
- 4 - TOTAL EXCAVATION MUST BE APPROVED BEFORE CONCRETE WORK COMMENCES.
- 5 - ALL EXPOSED CORNERS MUST BE BULLNOSED.
- 6 - 30MPa CONCRETE TO BE USED
- 7 - CONSTRUCTION JOINTS:
 - (a) REMOVE ALL FINE PARTICLES BY WASHING OFF WITH HIGH PRESSURE WATER ! 1 - 3 HOURS AFTER PLACING.
 - (b) KEEP CONSTANTLY WET UNTIL NEW CONCRETE IS POURED.
- 8 - CURING:

AFTER THE CONCRETE IS PLACED, THE EXPOSED SURFACE SHALL BE KEPT CONSTANTLY DAMP FOR AT LEAST 10 DAYS BY SUCH METHODS AS APPROVED BY THE ENGINEER.
- 9 - BLINDING LAYER IS NEEDED
- 10 - 250um PVC BOND BREAKER BETWEEN ALL FLOOR SLABS AND BLINDING LAYERS.
- 11 - SHUTTER FERRULES AND TIES SHALL BE OF THE CAST-IN TYPE, RUST RESISTANT AND WATERTIGHT. WITH 45mm MINIMUM CONCRETE COVER TO REINFORCING.
- 12 - VERTICAL ACCURACY MUST SUIT THE REQUIREMENTS OF GRADE 2.
- 13 - MINIMUM OVERLAP LENGTH 50 * Ø.
- 14 - MINIMUM COVER ON REINFORCEMENT:
 - WATER RETAINING STRUCTURES: 45mm
- 15 - BENDING AND HOOKING OF RODS SHALL BE DONE IN ACCORDANCE OF SABS SPESIFICATIONS 82.
- 16 - REINFORCING RODS:
 - (a) MILD STEEL SHALL COMPLY WITH REQUIREMENTS OF SABS SPECIFICATION 920 TYPE A OR B
 - (a) HIGH TENSILE STEEL SHALL COMPLY WITH REQUIREMENTS OF SABS SPECIFICATION 920 TYPE C OR D
- 17 - NO WELDING OF REINFORCEMENT WILL BE PERMITTED

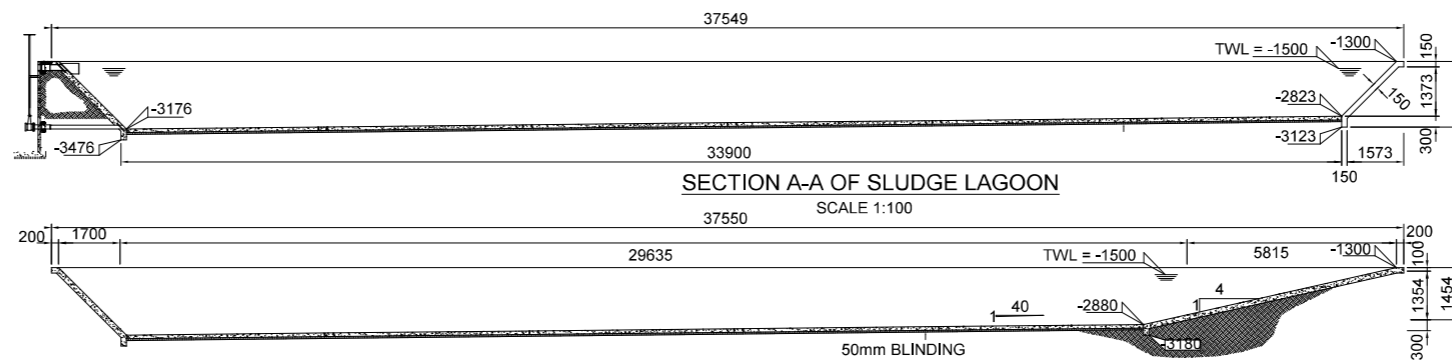
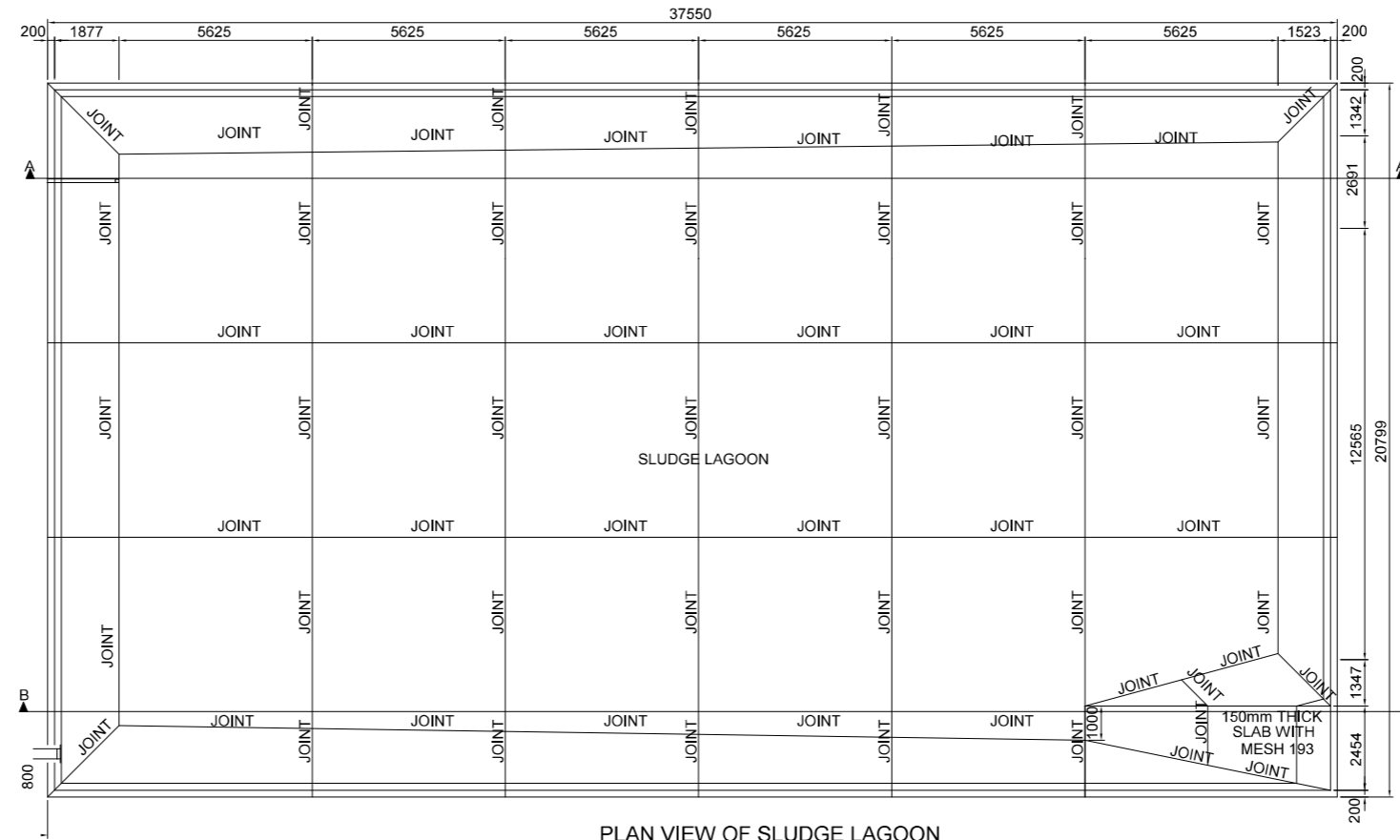
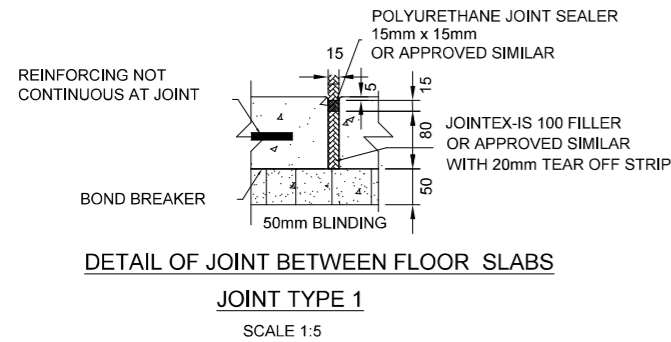
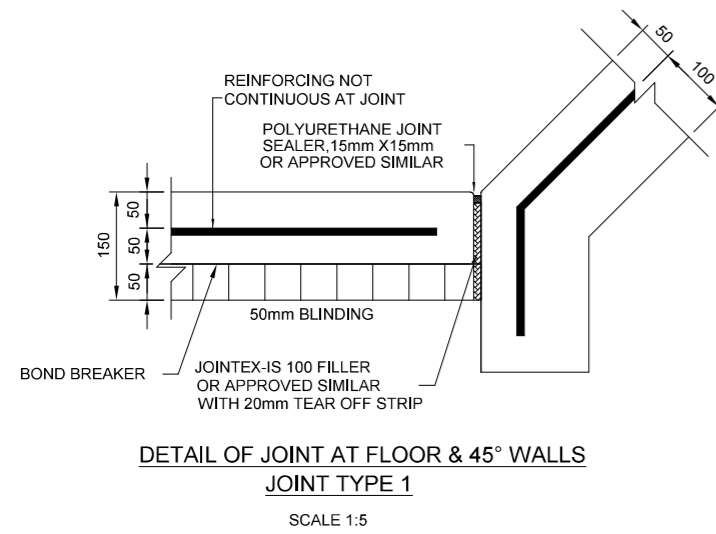

(LEVELS AND DIMENSIONS WILL CHANGE IN ACCORDANCE TO THE DESIGN)

Drawn	ES	Designed	FS	Signed	<i>[Signature]</i>
Checked	FS	Engineer	FS	Date	21 SEPT 2015
Client App.		Date	21 SEPT 2015		
FIGURE 1					
Drawing No					

REPORT

DRAWING REFERENCE			
No	Drg No	Title	NOTES

JOE GQABI DISTRICT MUNICIPALITY

STERKSPRUIT BULK SEWERAGE
INFRASTRUCTURE (RBIG) PROJECT

SLUDGE LAGOON DETAIL

PO Box 43335
HEUWELSIG
9332
Tel: 082 789 7594
Fax: 086 603 0220
e-mail: dibanani@vodamail.co.za



APPENDIX: **D**



Specialist Reports



DPR

Ecologists & Environmental Services

Report on the ecological and wetland assessment of the proposed construction of a Waste Water Treatment Works (WWTW) and associated bulk infrastructure in the town of Sterkspruit, Eastern Cape Province.

October 2020

Prepared by:

Darius van Rensburg

Pr.Sci.Nat. 400284/13

T 083 410 0770

darius@dprecologists.co.za

P.O. Box 12726 | 61 Topsy Smith Street
Brandhof | Langenhovenpark
9324 | 9300

Prepared for:
EKO Environmental
Suite 227
Private Bag X01
Brandhof
9324

DECLARATION OF INDEPENDENCE

DPR Ecologists and Environmental Services is an independent company and has no financial, personal or other interest in the proposed project, apart from fair remuneration for work performed in the delivery of ecological services. There are no circumstances that compromise the objectivity of the study.

Report Version	Final 1.0		
Title	Report on the ecological and wetland assessment of the proposed construction of a Waste Water Treatment Works (WWTW) and associated bulk infrastructure in the town of Sterkspruit, Eastern Cape Province.		
Author	DP van Rensburg (Pr.Sci.Nat)		Oct'20

Executive Summary

The proposed Waste Water Treatment Works (WWTW) will be constructed in the town of Sterkspruit on the banks of the Kromspruit along the northern peripheries of the town (Map 1 & 2). From the WWTW a series of bulk transport pipelines will be constructed to service the urban areas of the town and will include the areas of Sterkspruit, Esilindini, Tapoleng and Mokhesi. The WWTW consists of existing oxidation ponds but without any treatment plant. The site of the WWTW is therefore already largely transformed although it may still have an impact on the adjacent Kromspruit. The associated pipeline system will be situated within the urban area and although small portions of remaining vegetation is present these are also heavily degraded.

As indicated, the natural vegetation in the area has already been largely transformed by numerous impacts though largely associated with the urban area (Map 1). The WWTW site consists of existing oxidation ponds which has already transformed the majority of the site with remaining vegetation also heavily degraded and dominated by pioneer grasses. It was also noted that the oxidation ponds are leaking into the Kromspruit. The majority of the pipeline route will be situated within the urban area and consequently here the natural vegetation has been mostly removed. Low density urban areas dominate with rural farming activities also being prominent. Only a few small portions of remaining natural vegetation remain though it was also notable that even these areas are heavily degraded by overgrazing of domestic livestock. The pipeline network will largely follow the existing road network with large sections also situated along the R392 tarred road. Here the road reserve is also largely transformed. From the above it should be evident that the layout of the WWTW and associated pipelines is almost completely situated within transformed areas and should therefore considerably decrease the impact.

From the description of the vegetation on the WWTW site it should be abundantly clear that almost no natural vegetation remain and vegetation currently on the site is dominated by pioneer and exotic species. Overgrazing by domestic livestock is evidently quite high. Due to high levels of disturbance and transformation of the natural vegetation it is also highly unlikely that any species of conservation significance would be present. The proposed development of the WWTW should therefore not result in a significant impact on natural vegetation.

From the description of the vegetation along sections of the pipeline routes still consisting of natural vegetation it is clear that although vegetation remain here it is heavily modified and degraded from the natural condition. Pioneer species dominated and high levels of overgrazing by domestic livestock is evident. As a result of high levels of disturbance, it is considered unlikely that protected or Red Listed species would occur though this probability cannot completely be discounted. The high levels of disturbance and modification of the natural vegetation, low species diversity, the urban surroundings and the low likelihood of species of conservation importance occurring all contribute to decrease the impact that the proposed pipeline network will have.

The WWTW is situated adjacent to the Kromspruit River and final effluent will be discharged into the river (Map 2). In addition, the associated pipeline network will also cross over several watercourses and associated wetlands (Map 1).

The Kromspruit as well as watercourses being crossed by the pipeline network are all very similar in their functioning and can all be characterised as channel wetland systems with wetland conditions mainly present along the main channel (SANBI 2009). A few of the watercourses and especially the larger systems also contain a floodplain wetland system (SANBI 2009). This

accurately describes the wetland conditions which occurs in the floodplain of a few of the larger watercourses though was absent from the Kromspruit in the vicinity of the WWTW site.

Despite the poor condition of the Kromspruit and associated tributaries being crossed by the pipeline network they should all be considered as sensitive and providing essential services in terms of water transportation and ecological functioning. Furthermore, the Kromspruit is listed as a National Freshwater Ecosystems Priority Areas: Upstream System and forms part of the upstream catchment of the region and therefore plays an important role in water provision. This also substantiates the importance of the river

The Kromspruit and its associated tributaries are affected by numerous activities mostly as a result of the urban area of Sterkspruit. An Index of Habitat Integrity (IHI) was conducted for the Kromspruit. The results of this IHI also indicated that the Kromspruit in the area adjacent to the WWTW has an Instream IHI of category C/D: Moderately to Largely modified and a Riparian IHI of category D: Largely modified. A summary of these results are included in Appendix C. The EI&S of the Kromspruit and associated tributaries has been rated as being Moderate: Floodplains that are considered to be ecologically important and sensitive on a provincial or local scale. The biodiversity of these floodplains is not usually sensitive to flow and habitat modifications. They play a small role in moderating the quantity and quality of water of major rivers.

As previously indicated, though the WWTW will affect the Kromspruit, the proposed pipeline network will also cross several smaller watercourses and wetlands. All of these has been summarised separately within Section 4.3.6 of the report.

Spillages or leakages of sewage from the system into watercourses will cause significant impacts and this should be taken into account in the design, construction and management of the WWTW and associated pipeline network. A comprehensive monitoring programme should be initiated which should focus on the water quality within the Kromspruit adjacent to the WWTW. It is also recommended that bi-annual biomonitoring of the Kromspruit be initiated during the construction phase and sustained throughout its operation.

During construction the release of sediments and pollutants may occur into the Kromspruit. Likewise, during operation, flooding of the WWTW may contaminate the water within the river. In order to prevent this the footprint of the WWTW should remain outside the border of the upper zone (refer to Map 2). Storm water measures such as berms and cut-off trenches should be designed and implemented in order to keep dirty water within the operational area separate from the water within the Kromspruit. The Kromspruit and its banks should be treated as a no-go area and no activities either during construction or operation should encroach onto the banks.

The construction of the pipeline network and crossing of watercourses will also result in significant impacts. Although in most instances the pipeline will be constructed as a bridge attachment in these instances the impact will be low. However, installation of the pipeline may still result in the disturbance of the bed and banks of the watercourses. This in turn will promote erosion, prevent the banks from stabilising and lead to increased sedimentation of the watercourses. As a result disturbance of the banks should be kept to a minimum and erosion remediated where it occurs. As indicated in the descriptions of these watercourses, erosion is highly problematic and the implementation of erosion prevention structures may have to be considered. Where steep banks occur and erosion is evidently problematic it is recommended that geotextiles be utilised to stabilise soils. Available options include contouring, berms, gabions and geotextile netting.

Table of contents

Ecological and wetlands assessment.

Declaration of Independence

Executive Summary

1. Introduction	6
1.1 Background	
1.2 The value of biodiversity	
2. Scope and limitations	8
2.1 Vegetation	
2.2 Fauna	
2.3 Watercourses	
2.4 Limitations	
3. Methodology	10
3.1 Desktop study	
3.2 Survey	
3.3 Criteria used to assess sites	
3.4 Biodiversity sensitivity rating (BSR)	
4. Ecological and wetland assessment	14
4.1 Ecology and description of environment	14
4.2 Overview of fauna	19
4.3 Assessment of watercourses and wetlands	20
4.3.1 Introduction	20
4.3.2 Wetland indicators	21
4.3.3 Classification of wetland systems	22
4.3.4 Description of the Kromspruit	23
4.3.5 Condition and importance of the affected watercourses	27
4.3.6 Overview of each watercourse crossing	30
4.4 Anticipated impacts on watercourses	42
5. Ecological description of affected area	44
6. Biodiversity sensitivity rating (BSR)	45
7. Discussion and conclusions	46
8. Recommendations	50
9. References	52
Annexure A: Maps	55
Annexure B: Species list	59
Annexure C: Index of Habitat Integrity (IHI) Summary	61

Ecological and wetlands assessment

1. Introduction

1.1 Background

Natural vegetation is an important component of ecosystems. Some of the vegetation units in a region can be more sensitive than others, usually as a result of a variety of environmental factors and species composition. These units are often associated with water bodies, water transferring bodies or moisture sinks. These systems are always connected to each other through a complex pattern. Degradation of a link in this larger system, e.g. tributary, pan, wetland, usually leads to the degradation of the larger system. Therefore, degradation of such a water related system should be prevented.

Though vegetation may seem to be uniform and low in diversity it may still contain species that are rare and endangered. The occurrence of such a species may render the development unviable. Should such a species be encountered the development should be moved to another location or cease altogether.

South Africa has a large amount of endemic species and in terms of biological diversity ranks among the top ten in the world. This has the result that many of the species are rare, highly localised and consequently endangered. It is our duty to protect our diverse natural resources.

South Africa's water resources have become a major concern in recent times. As a water scarce country we need to manage our water resources sustainably in order to maintain a viable resource for the community as well as to preserve the biodiversity of the system. Thus, it should be clear that we need to protect our water resources so that we may be able to utilise this renewable resource sustainably. Areas that are regarded as crucial to maintain healthy water resources include wetlands, streams as well as the overall catchment of a river system.

Through our usage of our water resources for our daily needs we are also degrading the quality of our water resources. Thus, it is vital to improve the quality of the water effluent before it is returned to our water-ways. Therefore it is necessary to construct sewage plants at strategic locations to treat the waste water generated in residential and industrial areas on a daily basis. These waste plants must also be maintained and expanded as the growing population necessitates it. These waste plants must not be allowed to process a larger amount of waste than its capacity is able to process. If this is the case the plant should be expanded to prevent spillage of untreated waste into the natural water system.

The proposed Waste Water Treatment Works (WWTW) will be constructed in the town of Sterkspruit on the banks of the Kromspruit along the northern peripheries of the town (Map 1 & 2). From the WWTW a series of bulk transport pipelines will be constructed to service the urban areas of the town and will include the areas of Sterkspruit, Esilindini, Tapoleng and Mokhesi. The WWTW consists of existing oxidation ponds but without any treatment plant. The extent of the WWTW is approximately 3.6 hectares. The site of the WWTW is therefore already largely transformed although it may still have an impact on the adjacent Kromspruit. The associated pipeline system will be situated within the urban area and although small portions of remaining vegetation is present these are also heavily degraded. The pipelines will however also cross numerous watercourses and wetlands.

A site visit was conducted on 13 October 2020. The route of the pipeline was surveyed by means of a drive-through and sample plots at watercourses and portions of remaining natural vegetation while several transects were conducted at the WWTW site. The survey was conducted in early spring before the onset of the rainy season and consequently species identification was not optimal. However, sufficient plant identification was still possible in order to assess the ecological condition. It does however remain likely that several species were overlooked though given the degraded condition of the remaining vegetation it is unlikely that species of conservation concern will occur.

For the above reasons it is necessary to conduct an ecological and wetland assessment of an area proposed for development.

The report together with its recommendations and mitigation measures should be used to minimise the impact of the proposed development.

1.2 The value of biodiversity

The diversity of life forms and their interaction with each other and the environment has made Earth a uniquely habitable place for humans. Biodiversity sustains human livelihoods and life itself. Although our dependence on biodiversity has become less tangible and apparent, it remains critically important.

The balancing of atmospheric gases through photosynthesis and carbon sequestration is reliant on biodiversity, while an estimated 40% of the global economy is based on biological products and processes.

Biodiversity is the basis of innumerable environmental services that keep us and the natural environment alive. These services range from the provision of clean water and watershed services to the recycling of nutrients and pollution. These ecosystem services include:

- Soil formation and maintenance of soil fertility.
- Primary production through photosynthesis as the supportive foundation for all life.
- Provision of food, fuel and fibre.
- Provision of shelter and building materials.
- Regulation of water flows and the maintenance of water quality.
- Regulation and purification of atmospheric gases.
- Moderation of climate and weather.
- Detoxification and decomposition of wastes.
- Pollination of plants, including many crops.
- Control of pests and diseases.
- Maintenance of genetic resources.

2. Scope and limitations

- To evaluate the present state of the vegetation and ecological functioning of the area proposed for the WWTW and pipeline development.
- To identify possible negative impacts that could be caused by the proposed construction of the WWTW and associated pipeline.
- Identify and assess the Kromspruit and other watercourses being crossed by the pipelines including associated wetlands and ascertain condition and status therefore and recommend mitigation.

2.1 Vegetation

Aspects of the vegetation that will be assessed include:

- The vegetation types of the region with their relevance to the proposed site.
- The overall status of the vegetation on site.
- Species composition with the emphasis on dominant-, rare- and endangered species.

The amount of disturbance present on the site assessed according to:

- The amount of grazing impacts.
- Disturbance caused by human impacts.
- Other disturbances.

2.2 Fauna

Aspects of the fauna that will be assessed include:

- A basic survey of the fauna occurring in the region using visual observations of species as well as evidence of their occurrence in the region (burrows, excavations, animal tracks, etc.).
- The overall condition of the habitat.
- A list of species that may occur in the region (desktop study).

2.3 Watercourses

Aspects of the watercourses that will be assessed include:

- Identification of watercourses including rivers, streams, pans and wetlands.
- Describe condition and status of watercourses and importance relative to the larger system.
- Conduct habitat integrity assessment of perennial systems to inform the condition and status of watercourses.

2.4 Limitations

Several bulbous and herbaceous species may have finished flowering or has not yet flowered and these may have been overlooked or not identifiable.

Due to time constraints, only limited surveys of watercourses were done and concentrated on more significant watercourses.

Due to the length of the pipeline routes and numerous watercourses being crossed, assessment of the condition of the watercourses were limited to perennial systems, indicating the overall condition of watercourses in the area.

Some animal species may not have been observed as a result of their nocturnal and/or shy habits.

3. Methodology

3.1 Several literature works were used for additional information.

Vegetation:

Red Data List (Raymondo *et al.* 2009)

Vegetation types (Mucina & Rutherford 2006)

Field guides used for species identification (Bromilow 1995, 2010, Coates-Palgrave 2002, Fish *et al* 2015, Gerber *et al* 2004, Gibbs-Russell *et al* 1990, Griffiths & Picker 2015, Manning 2009, Moffett 1997, Pooley 1988, Pooley 2003, Retief & Meyer 2017, Van Ginkel *et al* 2011, Van Oudtshoorn 2004, Van Wyk & Malan 1998, Van Wyk & Van Wyk 1997, Venter & Joubert 1985).

Wetland methodology, delineation and identification:

Department of Water Affairs and Forestry 2004, 2005, Collins 2006, Duthie 1999, Kleynhans *et al* 2008, Marnewecke & Kotze 1999, Nel *et al* 2011, SANBI 2009.

Terrestrial fauna:

Field guides for species identification (Smithers 1986a, Child *et al* 2016).

3.2 Survey

The site was assessed by means of transects and sample plots.

- Noted species include rare and dominant species.
- The broad vegetation types present on the site were determined.
- The state of the environment was assessed in terms of condition, grazing impacts, disturbance by humans, erosion and presence of invader and exotic species.

Animal species were also noted as well as the probability of other species occurring on or near the site according to their distribution areas and habitat requirements.

The state of the habitat was also assessed.

The watercourses and associated wetlands were identified and surveyed where they were crossed by the pipeline or occurred in close proximity to the WWTW.

These systems were delineated by use of topography (land form and drainage pattern) and riparian vegetation.

The following were used to determine and delineate the rivers, streams, pans and wetlands:

- Department of Water Affairs and Forestry. 2005. A practical field procedure for identification and delineation of wetlands and riparian areas. Edition 1. Department of Water Affairs and Forestry, Pretoria.
- Marnewecke, G. & Kotze, D. 1999. Appendix W6: Guidelines for delineation of wetland boundary and wetland zones. In: MacKay (Ed.), H. Resource directed measures for protection of water resources: wetland ecosystems. Department of Water Affairs and Forestry, Pretoria.

The following were used to determine the sensitivity or importance of these identified watercourses:

- Nel, J.L., Murray, K.M., Maherry, A.M., Petersen, C.P., Roux, D.J., Driver, A., Hill, L., Van Deventer, H., Funke, N., Swartz, E.R., Smith-Adao, L.B., Mbona, N., Downsborough, L. and Nienaber, S. (2011). Technical Report for the National Freshwater Ecosystem Priority Areas project. WRC Report No. K5/1801.
- Government of South Africa. 2008. National Protected Area Expansion Strategy for South Africa 2008: Priorities for expanding the protected area network for ecological sustainability and climate change adaptation. Government of South Africa, Pretoria.

These guidelines provide the characteristics which can be utilised to determine if a wetland or watercourse is present and also aids in determining the boundary of these systems.

The following were utilised to inform the condition and status of watercourses:

- Kleyhans, C.J., Louw, M.D. & Graham, M. 2008. Module G: EcoClassification and EcoStatus determination in River EcoClassification: Index of Habitat Integrity. Joint Water Research Commission and Department of Water Affairs and Forestry report. WRC Report No. TT 377-08.

3.3 Criteria used to assess sites

Several criteria were used to assess the site and determine the overall status of the environment.

3.3.1 Vegetation characteristics

Characteristics of the vegetation in its current state. The diversity of species, sensitivity of habitats and importance of the ecology as a whole.

Habitat diversity and species richness: normally a function of locality, habitat diversity and climatic conditions.

Scoring: Wide variety of species occupying a variety of niches – 1, Variety of species occupying a single niche – 2, Single species dominance over a large area containing a low diversity of species – 3.

Presence of rare and endangered species: The actual occurrence or potential occurrence of rare or endangered species.

Scoring: Occurrence actual or highly likely – 1, Occurrence possible – 2, Occurrence highly unlikely – 3.

Ecological function: All plant communities play a role in the ecosystem. The ecological importance of all areas though, can vary significantly e.g. wetlands, drainage lines, ecotones, etc.

Scoring: Ecological function critical for greater system – 1, Ecological function of medium importance – 2, No special ecological function (system will not fail if absent) – 3.

Degree of rarity/conservation value:

Scoring: Very rare and/or in pristine condition – 1, Fair to good condition and/or relatively rare – 2, Not rare, degraded and/or poorly conserved – 3.

3.3.2 Vegetation condition

The sites are compared to a benchmark site in a good to excellent condition. Vegetation management practises (e.g. grazing regime, fire, management, etc.) can have a marked impact on the condition of the vegetation.

Percentage ground cover: Ground cover is under normal and natural conditions a function of climate and biophysical characteristics. Under poor grazing management, ground cover is one of the first signs of vegetation degradation.

Scoring: Good to excellent – 1, Fair – 2, Poor – 3.

Vegetation structure: This is the ratio between tree, shrub, sub-shrubs and grass layers. The ratio could be affected by grazing and browsing by animals.

Scoring: All layers still intact and showing specimens of all age classes – 1, Sub-shrubs and/or grass layers highly grazed while tree layer still fairly intact (bush partly opened up) – 2, Mono-layered structure often dominated by a few unpalatable species (presence of barren patches notable) – 3.

Infestation with exotic weeds and invader plants or encroachers:

Scoring: No or very slight infestation levels by weeds and invaders – 1, Medium infestation by one or more species – 2, Several weed and invader species present and high occurrence of one or more species – 3.

Degree of grazing/browsing impact:

Scoring: No or very slight notable signs of browsing and/or grazing – 1, Some browse lines evident, shrubs shows signs of browsing, grass layer grazed though still intact – 2, Clear browse line on trees, shrubs heavily pruned and grass layer almost absent – 3.

Signs of erosion: The formation of erosion scars can often give an indication of the severity and/or duration of vegetation degradation.

Scoring: No or very little signs of soil erosion – 1, Small erosion gullies present and/or evidence of slight sheet erosion – 2, Gully erosion well developed (medium to large dongas) and/or sheet erosion removed the topsoil over large areas – 3.

3.3.3 Faunal characteristics

Presence of rare and endangered species: The actual occurrence or potential occurrence of rare or endangered species on a proposed site plays a large role on the feasibility of a development. Depending on the status and provincial conservation policy, presence of a Red Data species or very unique and sensitive habitats can potentially be a fatal flaw.

Scoring: Occurrence actual or highly likely – 1, Occurrence possible – 2, Occurrence highly unlikely.

3.4 Biodiversity sensitivity rating (BSR)

The total scores for the criteria discussed in section 3.3 were used to determine the biodiversity sensitivity ranking for the sites. On a scale of 0 – 30, five different classes are described to assess the biodiversity of the study area. The different classes are described in the Table 1:

Table 1: Biodiversity sensitivity ranking

BSR	BSR general floral description	Floral score equating to BSR class
Totally transformed (5)	Vegetation is totally transformed or in a highly degraded state, generally has a low level of species diversity, no species of concern and/or has a high level of invasive plants. The area has lost its inherent ecological function. The area has no conservation value and potential for successful rehabilitation is very low.	29 – 30
Advanced Degraded (4)	Vegetation is in an advanced state of degradation, has a low level of species diversity, no species of concern and/or has a high level of invasive plants. The area's ecological function is seriously hampered, has a very low conservation value and the potential for successful rehabilitation is low.	26 – 28
Degraded (3)	Vegetation is notably degraded, has a medium level of species diversity although no species of concern are present. Invasive plants are present but are still controllable. The area's ecological function is still intact but may be hampered by the current levels of degradation. Successful rehabilitation of the area is possible. The conservation value is regarded as low.	21 – 25
Good Condition (2)	The area is in a good condition although signs of disturbance are present. Species diversity is high and species of concern may be present. The ecological function is intact and very little rehabilitation is needed. The area is of medium conservation importance.	11 – 20
Sensitive/Pristine (1)	The vegetation is in a pristine or near pristine condition. Very little signs of disturbance other than those needed for successful management are present. The species diversity is very high with several species of concern known to be present. Ecological functioning is intact and the conservation importance is high.	0 - 10

4. Ecological and wetland assessment

4.1 Ecology and description of environment

Refer to the species list in Appendix B.

According to Mucina & Rutherford (2006) the area consists of Zastron Moist Grassland (Gm 1) (Map 1). This vegetation type is not currently considered threatened according to the National Environmental Management: Biodiversity Act, 2004 (Act No. 10 of 2004). Furthermore, the majority of this vegetation type within this area has been transformed by the urban area and associated disturbances. This results in a significant decrease in the conservation value of any remaining vegetation.

The Eastern Cape Biodiversity Conservation Plan (ECBCP – 2007) has been published in order to identify areas which are essential to meeting conservation targets for specific vegetation types, i.e. Critical Biodiversity Areas. The WWTW and associated pipelines fall almost completely within a Critical Biodiversity Area 1 (CBA 1) as a result of it consisting of Maloti-Drakensberg critically endangered vegetation types (Map 3). However, the survey has confirmed that the development is almost completely situated within the urban area and that any remaining vegetation has also been heavily degraded. As a result, the conservation value will be relatively low.

The proposed Waste Water Treatment Works (WWTW) will be constructed in the town of Sterkspruit on the banks of the Kromspruit along the northern peripheries of the town (Map 1 & 2). From the WWTW a series of bulk transport pipelines will be constructed to service the urban areas of the town and will include the areas of Sterkspruit, Esilindini, Tapoleng and Mokhesi. The WWTW consists of existing oxidation ponds but without any treatment plant. The extent of the WWTW is approximately 3.6 hectares. The site of the WWTW is therefore already largely transformed although it may still have an impact on the adjacent Kromspruit. The associated pipeline system will be situated within the urban area and although small portions of remaining vegetation is present these are also heavily degraded. The pipelines will however also cross numerous watercourses and wetlands.

The area has quite a varied and uneven topography with hills, mountains, ridges, plateaus and plains dominating. The WWTW will be situated on a relatively flat alluvial plain adjacent to the Kromspruit. The river forms a horseshoe bend with the WWTW site located within this bend (Map 2). Steep hillslopes surround the site to the west, north and east. The WWTW will be situated at an elevation of 1436 m with the surrounding areas which will be serviced by the proposed pipeline network varying but having a maximum elevation of 1543 m. The decrease in altitude from the surrounding pipeline areas toward the WWTW clearly indicate the low lying position of the site and Kromspruit and will allow for gravitational flow, i.e. the location of the WWTW is important to allow for adequate functioning of the pipeline network.

As indicated, the natural vegetation in the area has already been largely transformed by numerous impacts though largely associated with the urban area (Map 1). The WWTW site consists of existing oxidation ponds which has already transformed the majority of the site with remaining vegetation also heavily degraded and dominated by pioneer grasses. It was also noted that the oxidation ponds are leaking into the Kromspruit. The adjacent Kromspruit, though also heavily modified, remains a sensitive system but will be discussed in detail in the wetland assessment section of the report. The majority of the pipeline route will be situated within the urban area and consequently here the natural vegetation has been mostly removed. Low density

urban areas dominate with rural farming activities also being prominent. Small portions between residential areas has for the most part been transformed by cropfields. Only a few small portions of remaining natural vegetation remain though it was also notable that even these areas are heavily degraded by overgrazing of domestic livestock. The pipeline network will largely follow the existing road network with large sections also situated along the R392 tarred road. Here the road reserve is also largely transformed. From the above it should be evident that the layout of the WWTW and associated pipelines is almost completely situated within transformed areas and should therefore considerably decrease the impact.

The area has been shown to be affected by Karoo invasion which is linked to overgrazing by domestic livestock, consequent erosion and the proliferation of dwarf karroid shrubs. Geologically the area is characterized by Molteno and Elliot Formations. The uppermost formation, namely the Clarens Formation forms exposed rocky cliffs along the summits of the larger mountains. The Ca and Ib land types are the most prominent in the study area. Generally the soils in the area are referred to as 'Podsollic' (pH < 7) soils with donga and surface erosion being a common phenomenon of these soils (Malan *et al* 1999). This was also clearly observed in the area. The rainfall is erratic and approximately 600-800 mm per annum.

As can be deduced from the above, the WWTW and pipeline routes will be largely situated in areas that has already been transformed (Map 1). Those small portions containing remnants of the natural vegetation was also found to be heavily degraded. An overview of the remnant vegetation will be provided below in order to substantiate the poor condition. A high number of watercourses and wetlands will also be affected by the pipeline but will be discussed in the following sections (Section 4.3.6).

Waste Water Treatment Works (WWTW) (Appendix A: Map 2)

The site of the WWTW has been almost completely transformed from the natural conditions (Map 2). A large portion of the site consists of the current oxidation ponds which, as can be expected, cause the transformation of a large portion of the site. The terrestrial portions around the oxidation ponds is dominated by a short grass layer and an abundance of exotic weeds neither of which is characteristic of the natural vegetation.

The grass layer is very short and heavily affected by overgrazing of domestic livestock. As a result the identification of grass species could not easily be done and it is likely that several grass species were overlooked and unidentifiable. The dominant grass species on the site included *Eragrostis lehmanniana*, *Hyparrhenia hirta*, *Aristida congesta*, *A. junciformis*, *Cynodon dactylon*, *Sporobolus africanus* and *Eleusine coracana*. Almost all of these are pioneer species and is a clear indication of extensive disturbance and transformation of the natural grass layer. In addition, the exotic *Pennisetum clandestinum* (Kikuyu) was also abundant, especially along the fringes of the oxidation ponds and is a further indication of transformation.

As indicated, exotic are also abundant and include *Argemone ochroleuca*, *Alternanthera pungens*, *Verbena bonariensis*, *Papaver aculeatum*, *Plantago lanceolata*, *Oxalis corniculata*, *Pseudognaphalium luteo-album*, *Tagetes minuta*, *Cirsium vulgare*, *Xanthium strumarium* and *Datura ferox*. These are also clear indicators of the degraded condition of the vegetation on the site.

A few herbaceous species are present though these are also all pioneer species common in disturbed areas. These species include *Salvia stenophylla*, *Tribulus terrestris*, *Gazania krebsiana*

and *Medicago lacineata*. Furthermore, the geophyte, *Moraea pallida*, is also very abundant. This is an indigenous species but is also a pioneer and poisonous to livestock and is a quite clear indication of degraded areas with a high degree of overgrazing by domestic livestock.

It was also noted that along the fringes of the WWTW dwarf karroid shrubs were also abundant, a further indication of high levels of overgrazing. These species included *Pentzia incana*, *Lycium horridum*, *Chrysocoma ciliata*, *Felicia fillifolia*, *F. muricata* and *Selago albida*.

From the description of the vegetation on the WWTW site it should be abundantly clear that almost no natural vegetation remain and vegetation currently on the site is dominated by pioneer and exotic species. Overgrazing by domestic livestock is evidently quite high. Due to high levels of disturbance and transformation of the natural vegetation it is also highly unlikely that any species of conservation significance would be present. The proposed development of the WWTW should therefore not result in a significant impact on natural vegetation. The Kromspruit adjacent to the site, although also heavily modified, does retain a high conservation value but will be discussed in the wetland assessment section of the study.



Figure 1: Panorama of the WWTW site, the location of the oxidation ponds are indicated. Note high levels of disturbance, a short grass layer and transformation of the natural vegetation.



Figure 2: Another view of the WWTW site. Again note heavily modified grass layer.

Bulk infrastructure network (Appendix A: Map 1)

As previously discussed the WWTW will also entail an extensive network of bulk transport pipelines (Map 1). These will be almost entirely situated within the urban surroundings. Small portions of vegetation remain along sections of the pipeline route though the following description should illustrate that these areas have also been heavily degraded by the surrounding urban areas and current land use.

The region is dominated by an uneven terrain with hills, ridges, mountains and plains and under natural conditions should be dominated by grassland with a shrub component being present to

varying degrees on the surrounding slopes. Due to high levels of overgrazing and trampling by domestic livestock the grass layer is very short with species not being easily identifiable. Pioneer species dominate and include *Hyparrhenia hirta*, *Eragrostis lehmanniana*, *Aristida congesta* and *Tragus koelerioides*. These are indicative of degraded natural vegetation.

Slopes also contain several dwarf shrubs and include *Felicia fillifolia*, *Melolobium sp.*, *Selago albida*, *Searsia erosa* and *Amphiglossa triflora*. These species would naturally form a component of the vegetation though where they significantly increase in abundance as is the case here, it is a clear indication of overgrazing.

Along slopes and rock ledges, shrubs and small trees are also present and include *Searsia burchellii* and *Diospyros lycioides*. These are considered a natural component of the vegetation. Other herbaceous species observed and which also form part of the natural vegetation include *Gazania krebsiana*, *Hermannia depressa* and *Barleria macrostegia*.

Disturbance of the natural vegetation also promote the establishment of exotic invasive species such as *Agave americana* and *Opuntia ficus-indica*. Stands of the exotic tree, *Eucalyptus camaldulensis* is also present in some areas and is utilised for firewood.

From the description of the vegetation along sections of the pipeline routes still consisting of natural vegetation it is clear that although vegetation remain here it is heavily modified and degraded from the natural condition (Map 1). Pioneer species dominated and high levels of overgrazing by domestic livestock is evident. As a result of high levels of disturbance it is considered unlikely that protected or Red Listed species would occur though this probability cannot completely be discounted. The high levels of disturbance and modification of the natural vegetation, low species diversity, the urban surroundings and the low likelihood of species of conservation importance occurring all contribute to decrease the impact that the proposed pipeline network will have.

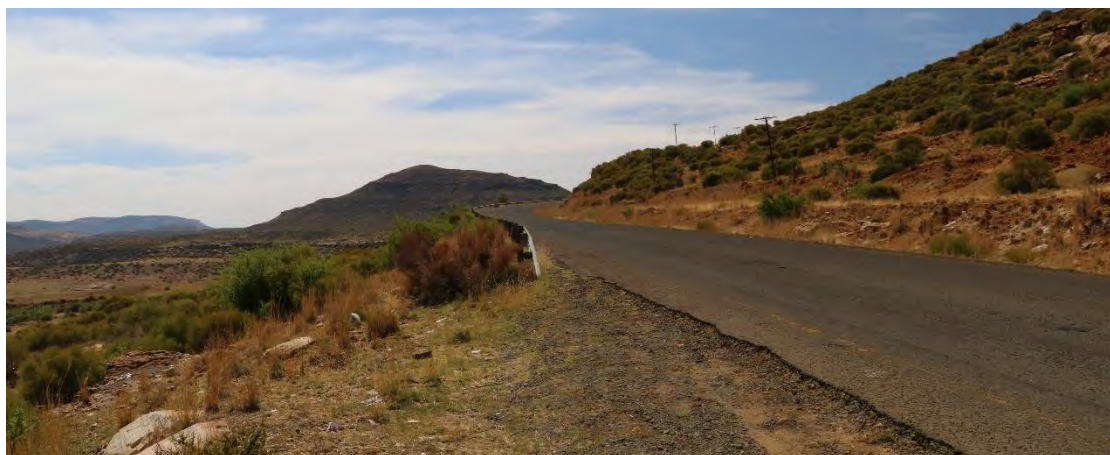

Figure 3: View of small portion of remaining natural vegetation along the pipelines route. Note a short grass layer with abundant shrubs along slopes.



Figure 4: Illegal dumping is highly problematic along the pipeline routes.



Figure 5: Another view of remaining natural areas. Though natural vegetation remain it is heavily modified.



Figure 6: Overgrazing in remaining natural areas are quite high and results in a short grass layer dominated by pioneer species.

4.2 Overview of fauna

Signs and tracks of mammals are largely absent from both the WWTW site and the associated pipeline network. This is most likely a result of the urban surroundings, transformation of the remaining natural areas and extensive overgrazing by domestic livestock. Coupled with livestock grazing are also an abundance of herding dogs which would also have a further significant impact on any remaining mammals. As a consequence it is considered highly unlikely that any species of conservation concern would remain in the area. Furthermore, any remaining mammals are considered highly likely to consist of generalist species able to survive in these urban and transformed areas.

Several soil mounds due to excavation by Common Mole, *Cryptomys hottentotus*, occur at the WWTW site as well as a few areas along the pipeline routes. This species is opportunistic and often occur in disturbed environments including urban gardens. The species is widespread, common and well adapted to disturbance and are not of a significant concern to the development. The species will vacate the site while construction occurs but will re-colonise the site as soon as construction ceases. However, the species should in no way be harmed during construction.

The oxidation ponds on the WWTW site support a high amount of water fowl. This is a common occurrence on almost any open water body such as the oxidation ponds. These waterbodies are also often utilised as overwintering areas by water fowl. During the site visit the following water fowl and water dependant birds were observed: *Ardea cinerea* (Grey Heron), *Theskiornis aethiopicus* (African Sacred Ibis), *Alopochen aegyptiaca* (Egyptian Goose), *Anas undulata* (Yellow-billed Duck), *Gallinula chloropus* (Common Moorhen) and *Fulica cristata* (Red-knobbed Coot). These species are all common inhabitants of any open water areas and are widespread. They can consequently not be considered as significant to conservation. It is also considered unlikely that any species of conservational concern would occur on the site as the oxidation dams contain inadequate habitat. The vegetation does not consist of any significant wetland areas which would be able to support wetland bird species of conservational concern. The water fowl currently utilising the oxidation ponds would also not be negatively affected to a high degree as they would merely relocate to adjacent water bodies and would return to the WWTW after construction.

The impact that the proposed WWTW and associated pipelines will have is mainly concerned with the loss of habitat. However, as previously indicated the habitat which will be affected has already been transformed and degraded to a large extent by the urban environment and associated land uses. Furthermore, the footprint of the development will not be extensive and should therefore limit the impact on mammals. The impact would also be mostly temporary as long as adequate rehabilitation is undertaken. Similar pipeline projects have indicated that adequate rehabilitation and topsoil management allows the affected area to return to a close to natural condition which would therefore re-instate the habitat for fauna and minimise the impact on the faunal population.

The hunting, capturing or harming in any way of fauna on the site must be prohibited. In the event of venomous animals, such as snakes, encountered on the site an experienced snake handler should be contacted to remove it from the site.

Table 2: Red Listed mammals likely to occur in the study area (Child *et al* 2016).

Common name	Scientific name	Status
SA hedgehog	<i>Erinaceus frontalis</i>	Near Threatened
Striped Weasel	<i>Poecilogale albinucha</i>	Near Threatened
White-tailed mouse	<i>Mastomys albicaudatus</i>	Vulnerable
Small spotted cat	<i>Felis nigripes</i>	Vulnerable
Vaal Rhebok	<i>Pelea capreolus</i>	Near Threatened
Serval	<i>Leptailurus serval</i>	Near Threatened
Brown Hyena	<i>Hyaena brunnea</i>	Near Threatened
Southern African Vlei Rat	<i>Otomys auratus</i>	Near Threatened
African Clawless Otter	<i>Aonyx capensis</i>	Near Threatened

The likelihood that one or several of these endangered species may occur on the site is considered highly unlikely.

4.3 Assessment of watercourses and wetlands

4.3.1 Introduction

The WWTW is situated adjacent to the Kromspruit River and final effluent will be discharged into the river (Map 2). In addition, the associated pipeline network will also cross over several watercourses and associated wetlands (Map 1). The Kromspruit will form the focus of this section though the pipeline crossings will also briefly be discussed.

The term watercourse refers to a river, stream, wetland or pan. The National Water Act (NWA, 1998) includes rivers, streams, pans and wetlands in the definition of the term watercourse. This definition follows:

Watercourse means:

- A river or spring.
- A natural channel in which water flows regularly or intermittently.
- A wetland, lake or dam into which water flows.
- Any collection of water which the Minister may, by notice in the Gazette, declare to be a watercourse, and a reference to a watercourse includes, where relevant, its bed and banks.

Riparian habitat is an accepted indicator of watercourses used to delineate the extent of wetlands, rivers, streams and pans (Department of Water Affairs and Forestry 2005).

The following guidelines and frameworks were used to determine and delineate the watercourses and wetlands being affected by the proposed WWTW and pipelines:

- Department of Water Affairs and Forestry. 2005. A practical field procedure for identification and delineation of wetlands and riparian areas. Edition 1. Department of Water Affairs and Forestry, Pretoria.
- Marnewecke & Kotze 1999. Appendix W6: Guidelines for delineation of wetland boundary and wetland zones. In: MacKay (Ed.), H. Resource directed measures for protection of water resources: wetland ecosystems. Department of Water Affairs and Forestry, Pretoria.

The classification of stream orders from 1 to 3 can be illustrated by means of the Strahler 1952 classification:

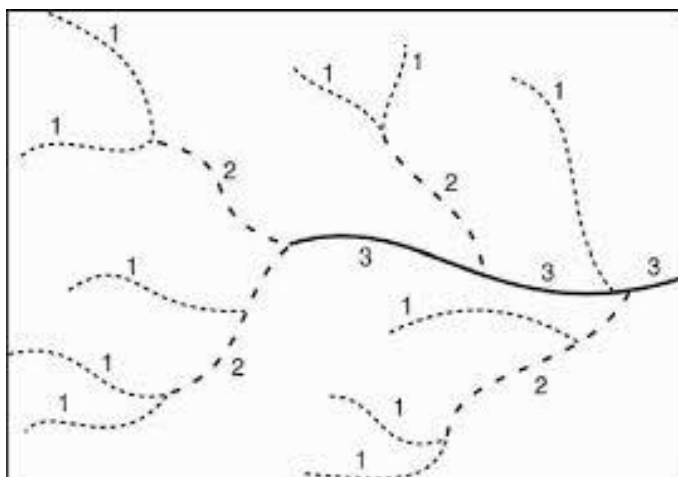

Figure 7: The classification of stream orders from 1 to 3 (Strahler 1952)

4.3.2 Wetland indicators

Obligate wetland vegetation was utilised to determine the presence and border of wetland conditions. Due to time constraints and the length of the associated pipeline network soil samples were only used to confirm the presence of wetland conditions where obligate wetland vegetation indicated wetland conditions (Section 4.3.6). Soil samples were investigated for the presence of anaerobic evidence which characterises wetland soils.

More detailed soil sampling was conducted along the banks of the Kromspruit at the WWTW site in order to provide a more accurate delineation of the wetland boundaries and riparian zone. Soil samples clearly indicate a perennial zone of wetness along the main channel and transition into a seasonal and temporary zone along the lower zone of the river (Map 2). The upper zone or bank of the river is however devoid of wetland conditions though still forming part of the riparian zone (Map 2). Obligate wetland plants along the marginal and lower zones of the river also clearly confirms the presence of wetland conditions here while the upper zone consists exclusively of terrestrial species.

Soil samples indicated that all of the watercourses being crossed by the pipeline network contain wetland conditions. The majority of these are however seasonal systems, i.e. flowing for only a portion of the year when rainfall occurs. It should however be kept in mind that wetland conditions occur as a result of saturated soils and not active flow or visible surface water. As a result, where soils in seasonal systems become saturated for short periods wetland conditions may occur. The majority of stream systems have a distinctive main channel and especially so where wetland conditions occur. As a result the topography also substantiate the occurrence of wetland conditions in these watercourses. Obligate wetland species clearly indicate the presence of wetland conditions in these watercourses. These species are listed for each specific watercourse (Section 4.3.6). Obligate wetland species are confined to wetlands and cannot occur in conditions outside of these systems. As a result, where they occur, wetland conditions can be considered to occur.

4.3.3 Classification of wetland systems

The Kromspruit as well as watercourses being crossed by the pipeline network are all very similar in their functioning and can all be characterised as channel wetland systems with wetland conditions mainly present along the main channel (SANBI 2009):

“An open conduit with clearly defined margins that (i) continuously or periodically contains flowing water, or (ii) forms a connecting link between two water bodies. Dominant water sources include concentrated surface flow from upstream channels and tributaries, diffuse surface flow or interflow, and/or groundwater flow. Water moves through the system as concentrated flow and usually exits as such but can exit as diffuse surface flow because of a sudden change in gradient. Unidirectional channel-contained horizontal flow characterises the hydrodynamic nature of these units. Note that, for purposes of the classification system, channels generally refer to rivers or streams (including those that have been canalised) that are subject to concentrated flow on a continuous basis or periodically during flooding, as opposed to being characterised by diffuse flow (see unchannelled valley-bottom wetland). As a result of the erosive forces associated with concentrated flow, channels characteristically have relatively obvious active channel banks. An active channel is a channel that is inundated at sufficiently regular intervals to maintain channel form and keep the channel free of established terrestrial vegetation. These channels are typically filled to capacity during bankfull discharge (i.e. during the annual flood, except for intermittent rivers **that do not flood annually).”**

This accurately describes the wetland conditions along the Kromspruit and watercourses being crossed by the pipeline network. In the majority of watercourses the wetland conditions are most prominent along the main channel and decrease in distance from the channel. However, a few watercourses also sustain a floodplain wetland system.

A few of the watercourses and especially the larger systems also contain a floodplain wetland system (SANBI 2009):

“The mostly flat or gently sloping wetland area adjacent to and formed by a Lowland or Upland Floodplain river, and subject to periodic inundation by overtopping of the channel bank. For purposes of the classification system, the location adjacent to a river in the Lowland or Upland Floodplain Zone is the key criterion for distinguishing a floodplain wetland from a channelled valley-bottom wetland. Water and sediment input to floodplain wetland areas is mainly via overtopping of a major channel, although there could be some overland or subsurface flow from adjacent valley side-slopes (if present). Water movement through the wetland is dominantly horizontal and bidirectional, in the form of diffuse surface flow and interflow, although there can be significant temporary containment of water in depressional areas (within which water movement is dominantly vertical and bidirectional). Water generally exits as diffuse surface flow and/or interflow, but infiltration and evaporation of water from a floodplain wetland can also be significant, particularly if there are a number of depressional areas within the wetland.”

This accurately describes the wetland conditions which occurs in the floodplain of a few of the larger watercourses though was absent from the Kromspruit in the vicinity of the WWTW site.

4.3.4 Description of the Kromspruit

The Kromspruit, its banks and riparian zone were surveyed along three transects across the channel and banks of the river.

Where FW or OW is indicated it refers to Facultative or Obligate Wetland species. A facultative wetland species is often associated with wetlands but is also able to occur in non-wetland areas. Obligate wetland species are confined to wetlands and are only able to occur in wetlands. They are therefore reliable indicators of wetland conditions. Field observations over time as well as the following sources were used to determine Facultative Wetland (FW) and Obligate Wetland (OW) species:

- Marnewecke, G. & Kotze, D. 1999. Appendix W6: Guidelines for delineation of wetland boundary and wetland zones. In: MacKay (Ed.), H. Resource directed measures for protection of water resources: wetland ecosystems. Department of Water Affairs and Forestry, Pretoria.
- DWAf. 2008. Updated manual for the identification and delineation of wetlands and riparian areas, prepared by M.Rountree, A.L. Batchelor, J. MacKenzie and D. Hoare. Stream Flow Reduction Activities, Department of Water Affairs and Forestry, Pretoria, South Africa.

Watercourses can be divided into different riparian zones within the lateral section of the system. These zones are as follows (Figure 14):

The marginal zone is the lowest zone and is always present in watercourses while the other two zones may not always be present. The zone is situated from the water level at low flow, if present, up to the features that are hydrologically activated for the most of the year (Figure 14). The marginal zone along the banks of the Kromspruit is easily distinguished and is dominated by sand banks, exposed rocky riverbed and a fringe of wetland vegetation along the **water's** edge. It is considered to be relatively intact though erosion is visible and vegetation also modified to a significant degree by overgrazing as well as the presence of exotic vegetation. Several obligate wetland plants are abundant in the marginal zone and include the sedge *Cyperus marginatus*, hygrophilous and semi-aquatic grasses such as *Paspalum distichum*, the fern *Equisetum ramosissimum* and several semi-aquatic herbaceous species such as *Centella asiatica*, *Gomphostigma virgatum*, *Persicaria lapathifolia* and *Berula erecta*. Wetland conditions are therefore clearly present within the marginal zone and saturated throughout the year (Map 2). As indicated, exotic species are also abundant and include *Pennisetum clandestinum*, *Oenothera rosea*, *Pseudognaphalium luteo-album* and *Plantago lanceolata*.



Figure 8: View of the marginal zone (red). Note erosion along the left bank with a sand bank, exposed rockbed and wetland vegetation along the margins.



Figure 9: View of the marginal (red). Note again erosion with sparse vegetation.

The lower zone is characterised by seasonal features and extends from the marginal zone up to an area of marked elevation. This area may be accompanied by a change in species distribution patterns. The lower zone consists of geomorphic features that are activated on a seasonal basis (Figure 14). The lower zone along this section of the river is quite uniform and consist of a moderately steep bank with a width of approximately 10 meters. The vegetation here is quite modified and often dominated by the exotic grass, *Pennisetum clandestinum*. The zone is also affected by erosion which results in the exposure of sandbanks. The species diversity is very low although a few obligate wetland plants are still present and indicative of a seasonal zone of wetness (Map 2). Obligate wetland plants include the grass, *Leptochloa fusca* and the sedge, *Cyperus marginatus*. Overgrazing is quite high in this zone and it is likely that several species may have been overlooked. Terrestrial species are also present and indicate the transitional nature of this zone. These species include, *Passerina montana*, *Gazania krebsiana*, *Sporobolus africanus* and *Artemisia afra*. Exotic weeds are present though not abundant and include *Tagetes*

minuta and *Papaver aculeatum*. However, keep in mind that the exotic grass, *P. clandestinum* is dominant and still indicates significant modification of this zone.



Figure 10: The lower zone is clearly visible between the marginal (red) and upper (yellow) zones. It consists of a short grass layer dominated by the exotic *Pennisetum clandestinum*.



Figure 11: Another view of the lower zone indicating the relatively broad grassy slope. The marginal (red) and upper zones (yellow) are indicated.

The upper zone is characterised by ephemeral features as well as the presence of both riparian and terrestrial species. The zone extends from the lower zone to the riparian corridor. The upper zone contains geomorphic features that are hydrologically activated on an ephemeral basis (Figure 14). This zone is discernible where the floodplain of the river levels off from the lower zone and is dominated by a definite but more gradual slope. Essentially this zone consists of the floodplain or riparian zone of the river (Map 2). The zone is heavily modified by overgrazing of domestic livestock and the oxidation ponds also encroach into it, further modifying it. It is completely dominated by terrestrial vegetation and is dominated by grasses and dwarf karroid shrubs. Grass species include *Aristida congesta*, *Digitaria eriantha* and *Sporobolus africanus*. Dwarf karroid shrubs include *Selago albida*, *Pentzia incana*, *Lycium horridum*, *Chrysocoma ciliata*, *Felicia muricata* and *F. fillifolia*. This assemblage of species is indicative of high levels of overgrazing. The geophyte, *Moraea pallida* is also very abundant. This is an indigenous species but is also a pioneer and poisonous to livestock and is a quite clear indication of degraded areas with a high degree of overgrazing by domestic livestock. Exotic weeds are also very abundant and further substantiates the degraded condition of the riverbanks. These include *Argemone ochroleuca*, *Schkuhria pinata*, *Anthemis cotula*, *Papaver aculeatum* and *Tagetes minuta*.



Figure 12: The upper zone (red) is easily distinguished from the lower zone. Note the high abundance of the pioneer geophyte, *Moraea pallida* (yellow flowers).



Figure 13: Another view of the upper zone (red).

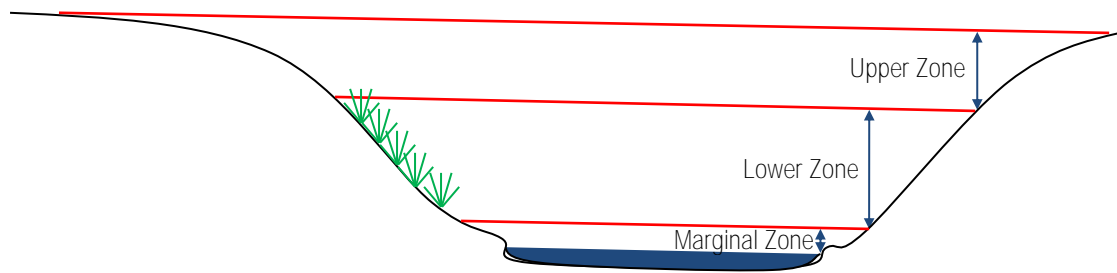

Figure 14: Illustration showing the different riparian zones at the Kromspruit adjacent to the WWTW.

4.3.5 Condition and importance of the affected watercourses

Due to the high number of watercourses being crossed by the pipeline a determination of the Index of Habitat Integrity (IHI) will only be conducted for the perennial Kromspruit which will be affected by the WWTW (Appendix C). The remaining smaller watercourses which will be crossed by the pipeline network all drain in to this system and they therefore form part of the same system being affected by the same impacts and will also impact the same downstream areas (Map 1). The impacts in the catchment will also be discussed as a whole and the effect on these watercourses taken into account and the condition of the watercourses should therefore be determined with relative accuracy. This is considered to give an adequate representation of the overall condition of the Kromspruit affected by the WWTW and watercourses being crossed by the pipeline network. The IHI will be taken as representative of the Present Ecological State (PES) of these systems.

Table 3 refers to the determination and categorisation of the Present Ecological State (PES; health or integrity) of various biophysical attributes of rivers relative to the natural or close to the natural reference condition. The purpose of the EcoClassification process is to gain insights and understanding into the causes and sources of the deviation of the PES of biophysical attributes from the reference condition. This provides the information needed to derive desirable and attainable future ecological objectives for the river (Kleynhans & Louw 2007).

Table 4 refers to the Ecological Importance and Sensitivity (EIS) of wetlands. "Ecological importance" of a water resource is an expression of its importance to the maintenance of ecological diversity and functioning on local and wider scales. "Ecological sensitivity" refers to the system's ability to resist disturbance and its capability to recover from disturbance once it has occurred. The Ecological Importance and Sensitivity (EIS) provides a guideline for determination of the Ecological Management Class (EMC).

Table 3: Ecological categories for Present Ecological Status (PES).

Ecological Category	Description
A	Unmodified, natural
B	Largely natural with few modifications. A small change in natural habitats and biota may have taken place but the ecosystem functions are essentially unchanged.
C	Moderately modified. Loss and change of natural habitat and biota have occurred, but the basic ecosystem functions are still predominately unchanged.
D	Largely modified. A large loss of natural habitat, biota and basic ecosystem function has occurred.
E	Seriously modified. The loss of natural habitat, biota and basic ecosystem functions is extensive.
F	Critically/Extremely modified. Modifications have reached a critical level and the system has been modified completely with an almost complete loss of natural habitat and biota. In the worst instances the basic ecosystem functions have been destroyed and the changes are irreversible.

Table 4: Ecological importance and sensitivity categories.

Ecological Importance and Sensitivity Category (EIS)	Range of Median	Recommended Ecological Management Class
Very High Floodplains that are considered ecologically important and sensitive on a national or even international level. The biodiversity of these floodplains is usually very sensitive to flow and habitat modifications. They play a major role in moderating the quantity and quality of water of major rivers.	>3 and <=4	A
High Floodplains that are considered to be ecologically important and sensitive. The biodiversity of these floodplains may be sensitive to flow and habitat modifications. They play a role in moderating the quantity and quality of water of major rivers.	>2 and <=3	B
Moderate Floodplains that are considered to be ecologically important and sensitive on a provincial or local scale. The biodiversity of these floodplains is not usually sensitive to flow and habitat modifications. They play a small role in moderating the quantity and quality of water of major rivers.	>1 and <=2	C
Low/marginal Floodplains that are not ecologically important and sensitive at any scale. The biodiversity of these floodplains is ubiquitous and not sensitive to flow and habitat modifications. They play an insignificant role in moderating the quantity and quality of water of major rivers.	>0 and <=1	D

Desktop assessments of the Kromspruit was previously conducted (Kleynhans 2000). However, the current assessment has indicated that this is not an accurate estimate, at least for this section of the river being affected by the Sterkspruit urban area.

Despite the poor condition of the Kromspruit and associated tributaries being crossed by the pipeline network they should all be considered as sensitive and providing essential services in terms of water transportation and ecological functioning. Furthermore, the Kromspruit is listed as a National Freshwater Ecosystems Priority Areas: Upstream System and forms part of the upstream catchment of the region and therefore plays an important role in water provision. This also substantiates the importance of the river

However, several large impacts cause a high level of modification of the river. The area is subjected to heavy and sustained overgrazing which has led to significantly low vegetation cover which in turn leads to greater runoff, increased erosion and high sediment loads. The area contains a moderate density but expansive area of residential and light industrial development. This area is also highly affected by insufficient sewage systems and is highly affected by rubbish dumping and littering. As a result the runoff from these residential areas is highly polluted and has a high impact on the Kromspruit. Algal growth is abundant and also indicates high nutrient levels as a result of pollution. High nutrient levels also promote dominance by exotic weeds and invaders. These areas also lack surface cover in the form of vegetation or paving. As a result the area is subjected to high erosion, increased sediment loads and increased runoff which further negatively impacts on the Kromspruit. The river would naturally have a seasonal to slightly perennial flow. However, due to increased runoff from urban areas it has now become perennial. This is considered a large alteration to the flow and flood regime. It has also had a significant impact on the riparian vegetation and the composition and structure thereof. The existing WWTW has oxidation ponds where sewage is being pumped into. These ponds are deteriorating and leaking and as a result highly polluted water enters the Kromspruit and causes high levels of pollution, algal blooms and consequently eutrophication of the river. The Kromspruit is also subjected to several other impacts including bridge crossing of roads, abstraction for irrigation, polluted runoff from irrigated and dryland crop cultivation, rubbish dumping and excavation of material from the river.

The riparian vegetation along the Kromspruit has been severely degraded and vegetation cover is quite low. As previously indicated, exotic weeds and Kikuyu Grass (*Pennisetum clandestinum*) also dominated large portions of the riparian vegetation. Through high amounts of overgrazing, trampling and over utilisation of the river and its banks the riparian vegetation has been severely degraded. No protected, rare or endangered species occur along the river and due to the high level of disturbance it is also considered unlikely.

From the above it should be clear that the Kromspruit and its associated tributaries are affected by numerous activities mostly as a result of the urban area of Sterkspruit. An Index of Habitat Integrity (IHI) was conducted for the Kromspruit. The results of this IHI also indicated that the Kromspruit in the area adjacent to the WWTW has an Instream IHI of category C/D: Moderately to Largely modified and a Riparian IHI of category D: Largely modified. A summary of these results are included in Appendix C.

The EI&S of the Kromspruit and associated tributaries has been rated as being Moderate: Floodplains that are considered to be ecologically important and sensitive on a provincial or local scale. The biodiversity of these floodplains is not usually sensitive to flow and habitat

modifications. They play a small role in moderating the quantity and quality of water of major rivers.

Although highly degraded the Kromspruit remains a vital water resource. It is anticipated that the construction of a new WWTW would alleviate the current impacts on the river and should therefore improve its condition.

As previously indicated, though the WWTW will affect the Kromspruit, the proposed pipeline network will also cross several smaller watercourses and wetlands (Map 1). All of these will be summarised separately within Section 4.3.6 of the report.

4.3.6 Overview of each watercourse crossing

The following description will provide a short description of each watercourse being crossed by the pipeline network (Table 5) (Map 1 & 2).

Where FW or OW is indicated it refers to Facultative or Obligate Wetland species. A facultative wetland species is often associated with wetlands but is also able to occur in non-wetland areas. Obligate wetland species are confined to wetlands and are only able to occur in wetlands. They are therefore reliable indicators of wetland conditions. Field observations over time as well as the following sources were used to determine FW and OW species:

- Marnewecke, G. & Kotze, D. 1999. Appendix W6: Guidelines for delineation of wetland boundary and wetland zones. In: MacKay (Ed.), H. Resource directed measures for protection of water resources: wetland ecosystems. Department of Water Affairs and Forestry, Pretoria.
- DWAF. 2008. Updated manual for the identification and delineation of wetlands and riparian areas, prepared by M.Rountree, A.L. Batchelor, J. MacKenzie and D. Hoare. Stream Flow Reduction Activities, Department of Water Affairs and Forestry, Pretoria, South Africa.

Table 5: Description of the specific points of crossing by the proposed pipeline network over watercourses and wetlands (Map 1 & 2) (FW – Facultative wetland species, OW – Obligate wetland species, * - Exotic species).

Watercourse name: #1 Unnamed drainage line – Tributary of the Kromspruit	Coordinates of crossing: S 30.518131°, E 27.379398°	Flow regime: Seasonal drainage line
<p>Description of watercourse: A small drainage line forming a distinct channel but which is clearly only seasonal in nature. It is evidently quite heavily modified and affected by severe erosion, located within the urban area and therefore also affected by it and crossed by several roads, including the R392 tarred road at the site. Drainage of the culverts underneath the road is quite poor and will also affect the flow of the drainage line. The drainage line originates a short distance to the west and flows into the Kromspruit to the south.</p> <p>Soils within the stream is clearly indicative of a seasonal zone of wetness with clear mottling and a grey matrix (<10%). Obligate wetland plants are not well represented though identification could not be easily done due to overgrazing and it is possible that several other</p>		

wetland plants area present. Exotic weeds are abundant and also indicate the poor condition of the drainage line.

Dominant plant species:



Paspalum distichum (OW), *Conyza podocephala*, **Sonchus oleraceus*, **Anthemis cotula*, *Moraea pallida*, **Argemone ochroleuca*, **Pennisetum clandestinum*, **Plantago lanceolata*, **Bidens bipinnata*, *Diospyros lycioides*, *Gazania krebsiana*, *Lycium cinerium*, **Tagetes minuta*, *Hyparrhenia hirta*.

Protected plant species:

None observed.

Soil sample:



Watercourse name: #2 Unnamed stream - tributary of the Kromspruit	Coordinates of crossing: S 30.519968°, E 27.379228° S 30.520361°, E 27.378877°	Flow regime: Seasonal stream
<p>Description of watercourse: A small seasonal stream which will be crossed by the pipeline at two locations adjacent to each other and which confluences with the Kromspruit a short distance of approximately 1 km downstream of the site. The stream is modified to a significant degree though erosion is not as prominent at the site of crossing. The urban surroundings and significant rubbish dumping does impact on the stream. The R392 tarred road also crosses the stream and will further impact on it. A clear and quite deep channel is present.</p> <p>The streambed is dominated by bedrock and adequate soil sampling could not be done. A thin sand layer is present but is not sufficient to indicate wetland conditions. However, significant obligate wetland vegetation is present to confirm wetland conditions, at least along the main channel. Exotic weeds are abundant and confirm a degraded condition for the stream.</p>		
<p>Dominant plant species: <i>Diopsiros lycioides</i>, *<i>Pennisetum clandestinum</i>, *<i>Rosa rubiginosa</i>, <i>Selago albida</i>, <i>Moraea pallida</i>, <i>Eragrostis lehmanniana</i>, <i>Leptochloa fusca</i> (OW), <i>Hyparrhenia hirta</i>, <i>Salvia verbenaca</i>, *<i>Tagetes minuta</i>, *<i>Agave americana</i>, <i>Cyperus marginatus</i> (OW), *<i>Schkuhria pinata</i>.</p>		
<p>Protected plant species: None observed.</p>		
<p>Soil sample:</p>		
		
		



Watercourse name: #3 Kromspruit – Bridge crossing	Coordinates of crossing: S 30.524390°, E 27.371659°	Flow regime: Perennial river
--	--	---------------------------------

Description of watercourse:
The Kromspruit will be crossed by one of the bulk transport pipelines a short distance upstream of the WWTW by means of a bridge crossing. Please refer to a comprehensive description of the river and its conditions under section 4.3.4. and 4.3.5.

Dominant plant species:
Refer to section 4.3.4.

Protected plant species:
None observed

Soil sample:



Watercourse name: #4 Unnamed stream – tributary of the Kromspruit.	Coordinates of crossing: S 30.543412°, E 27.379140°	Flow regime: Seasonal stream
<p>Description of watercourse:</p> <p>This is quite a large stream which drains into the Kromspruit a short distance, approximately 1 km, to the north. The pipeline will cross the stream also occur in close proximity to it for a short distance. The stream is evidently quite heavily affected by the surrounding urban area with erosion being prominent. Rubbish dumping is also abundant and the dumping of used diapers is also worrying as this will lead to high levels of pollution. The stream is also already affected by road and infrastructure crossings. The stream has a distinct and wide main channel and it is evident that though it does not flow throughout the year, surface water and pools are always present.</p> <p>The streambed is dominated by cobbles and sand and as a result soil samples did not exhibit distinct wetland conditions. However, obligate wetland vegetation is abundant along the main channel and confirm the presence of wetland conditions. Exotic weeds are not as abundant though it remains clear that the stream is quite heavily degraded.</p>		
<p>Dominant plant species:</p> <p><i>Juncus rigidus</i> (OW), <i>Salvia stenophylla</i>, <i>Cyperus</i> sp., *<i>Verbena tenuisecta</i>, *<i>Pseudognaphalium luteo-album</i>, <i>Conyza podocephala</i>, <i>Moraea pallida</i>, <i>Cyperus marginatus</i> (OW), <i>Berula erecta</i>, <i>Salvia verbenaca</i>, <i>Cynodon dactylon</i>.</p>		
<p>Protected plant species:</p> <p>None observed</p>		
<p>Soil sample:</p> 		



Watercourse name: #5 Unnamed stream – tributary of the Kromspruit	Coordinates of crossing: S 30.529410°, E 27.348249° S 30.535210°, E 27.346717° S 30.544729°, E 27.344046°	Flow regime: Seasonal stream
Description of watercourse: This is quite a large stream which drains into the Kromspruit a short distance, approximately 1 km, to the north. The pipeline will cross the stream at three separate locations. The stream is evidently quite heavily affected by the surrounding urban area with erosion being prominent. Rubbish dumping is also abundant and the dumping of used diapers is also worrying as this will lead to high levels of pollution. The stream is also crossed by the R392 tarred road.		

Overgrazing by domestic stock along its banks was also noted to be quite high and brick making using the clays along the stream was also extensive. These impacts will all cause significant modification and degradation of the stream. The stream has a distinct and wide main channel and it is evident that though it does not flow throughout the year, surface water and pools are always present.

Soils along the stream indicated a prominent grey matrix and mottling and indicate clear seasonal wetland conditions. This is also confirmed by an abundance of obligate wetland vegetation along the banks. Exotic weeds are not as abundant although the exotic grass, *Pennisetum clandestinum*, is quite abundant. The stream is clearly heavily degraded by surrounding land use.

Dominant plant species:

Moraea pallida, *Cyperus marginatus* (OW), *Cyperus sp.*, **Pseudognaphalium luteo-album*, **Plantago lanceolata*, **Pennisetum clandestinum*, *Gazania krebsiana*, *Chrysocoma ciliata*, *Felicia muricata*, *Eragrostis lehmanniana*, *Berula erecta*, *Medicago lacinata*, *Diospyros lycioides*.

Protected plant species:

None observed

Soil sample:





Watercourse name: #6 Unnamed stream – upstream tributary of #5 stream	Coordinates of crossing: S 30.549772°, E 27.338470° S 30.551482°, E 27.327565°	Flow regime: Seasonal stream
<p>Description of watercourse:</p> <p>This is a small stream which forms the upper reaches of the #5 stream system. The pipeline will cross the stream at two separate locations. The stream is quite heavily affected by erosion, not clearly evident at the site, but prominent in the upstream reaches. Being located on the outskirts of the urban area it seems to be somewhat less affected by rubbish dumping. It is however crossed by a gravel road which will impact on its flow regime and overgrazing and trampling by domestic stock is quite high. Though less affected the stream will here still be quite significantly modified. A distinct channel is present though clearly much smaller than downstream sections and will here be strictly seasonal in flow regime.</p> <p>Soils along the stream indicated a prominent grey matrix and mottling and indicate clear seasonal wetland conditions. This is also confirmed by an abundance of obligate wetland</p>		

vegetation along the banks. Exotic weeds are abundant and also confirm it to be quite degraded.

Dominant plant species:

Moraea pallida, *Cyperus marginatus* (OW), **Oxalis corniculata*, *Leptochloa fusca*, **Argemone ochroleuca*, **Pseudognaphalium luteo-album*, **Pennisetum clandestinum*.

Protected plant species:

None observed

Soil sample:



Watercourse name: #7 Unnamed stream – tributary of the Kromspruit	Coordinates of crossing: S 30.536590° , E 27.316204°	Flow regime: Seasonal stream
--	---	---------------------------------

Description of watercourse:
This is a small stream system originating nearby to the east of the crossing. It is also a tributary of the Kromspruit and drains into it to the north of the site (approximately 3 km). From the survey of the stream it seems to be heavily affected by the surrounding urban areas. Erosion is quite prominent in the catchment, with prominent rubbish dumping and high algal concentrations indicating elevated nutrient values. The stream is also crossed by the R392 tarred road. Overgrazing by domestic stock along its banks was also noted to be quite high. These impacts will all cause significant modification and degradation of the stream. The stream has a distinct though narrow channel and is clearly only seasonal in nature.

Soils along the stream indicated a prominent grey matrix and mottling and indicate clear seasonal wetland conditions. This is also confirmed by an abundance of obligate wetland vegetation along the banks. Exotic weeds are not as abundant though it is still clear that it is heavily affected by surrounding land use.

Dominant plant species:
Moraea pallida, *Diospyros lycioides*, *Searsia erosa*, *Typha capensis* (OW), *Crassula natans*, *Cyperus marginatus* (OW), *Cyperus sp.*, *Pentzia incana*, *Selago albida*, *Leptochloa fusca* (OW).

Protected plant species:
None observed

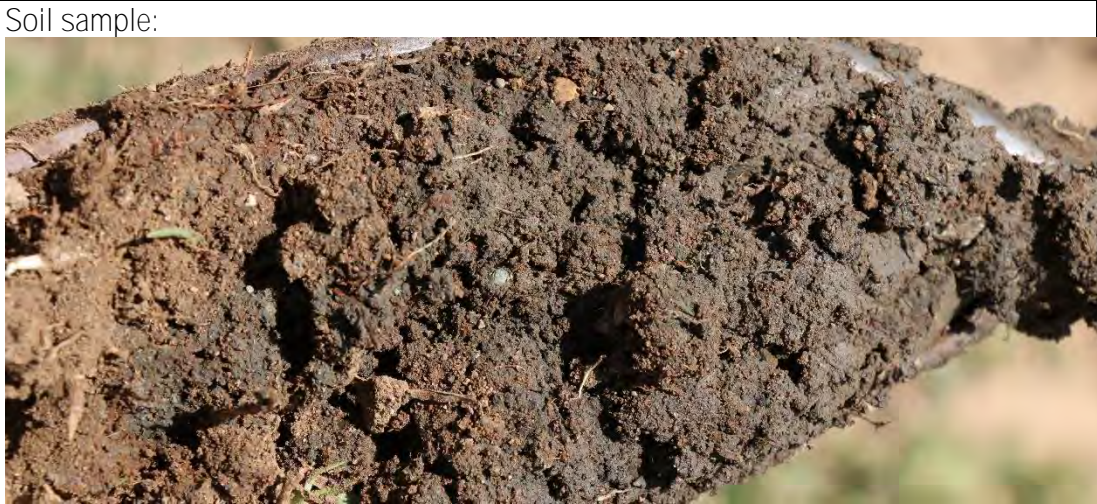



<p>Watercourse name: #8 Unnamed drainage line – tributary of stream #5</p>	<p>Coordinates of crossing: S 30.533042°, E 27.343020°</p>	<p>Flow regime: Seasonal drainage line</p>
<p>Description of watercourse: A small drainage line forming a distinct and deep channel but which is clearly only seasonal in nature. It is evidently quite heavily modified and affected by severe erosion, subjected to high levels of overgrazing and crossed by the R392 tarred road at the site. The drainage line is situated near its origin in an areas with steep slopes which also contributes to the severe effect of erosion. It flows into stream #5 a short distance downstream (approximately 400 meters).</p> <p>Soils within the drainage line has a high gravel content and wetland conditions are not clearly apparent. This may also be associated with the high levels of erosion here. However, obligate wetland plants are present and confirm the presence of wetland conditions although clearly only on a seasonal nature. Although exotic plants are not abundant it is clear that the drainage line is severely degraded and affected by high levels of erosion.</p>		
<p>Dominant plant species: <i>*Agave americana, Felicia fillifolia, Hyparrhenia hirta, Diospyros lycioides, Searsia erosa, Aristida junciformis, Selago albida, Gazania krebsiana, *Plantago lanceolata, Juncus rigidus</i></p>		

(OW), *Juncus exertus* (OW), *Senecio consanguineus*, *Stoebe plumosa*, **Oenothera stricta*,
Jamesbrittenia aurantiaca, **Bidens bipinnata*.

Protected plant species:
None observed

Soil sample:





4.4 Anticipated impacts on watercourses

The construction of the WWTW will largely affect the Kromspruit while the associated pipeline network will impact on surrounding watercourses (Map 1 & 2).

Spillages or leakages of sewage from the system into watercourses will cause significant impacts and this should be taken into account in the design, construction and management of the WWTW and associated pipeline network.

A comprehensive monitoring programme should be initiated which should focus on the water quality within the Kromspruit adjacent to the WWTW. At least two monitoring points must be established; one upstream and one downstream. These must be analysed on a monthly basis to determine if the WWTW is causing pollution of the Kromspruit. It is also recommended that bi-annual biomonitoring of the Kromspruit be initiated during the construction phase and sustained throughout its operation. This should include SASS5 and IHI indices during the wet- and dry seasons.

During construction the release of sediments and pollutants may occur into the Kromspruit. Likewise, during operation, flooding of the WWTW may contaminate the water within the river. In order to prevent this the footprint of the WWTW should remain outside the border of the upper zone (refer to Map 2). Storm water measures such as berms and cut-off trenches should be designed and implemented in order to keep dirty water within the operational area separate from the water within the Kromspruit. This should also prevent flooding of the WWTW. The Kromspruit and its banks should be treated as a no-go area and no activities either during construction or operation should encroach onto the banks.

The construction of the pipeline network and crossing of watercourses will also result in significant impacts. Although in most instances the pipeline will be constructed as a bridge attachment in these instances the impact will be low. However, installation of the pipeline may still result in the disturbance of the bed and banks of the watercourses. This in turn will promote erosion, prevent the banks from stabilising and lead to increased sedimentation of the watercourses. As a result disturbance of the banks should be kept to a minimum and erosion remediated where it occurs. As indicated in the descriptions of these watercourses, erosion is

highly problematic and the implementation of erosion prevention structures may have to be considered. Where steep banks occur and erosion is evidently problematic it is recommended that geotextiles be utilised to stabilise soils. Available options include contouring, berms, gabions and geotextile netting.

The following general mitigation should also be implemented at the WWTW and pipeline network where applicable:

- The disturbance caused by construction will also cause susceptible conditions for further establishment of exotics. It is therefore recommended that weed eradication be initiated at the WWTW and crossing sites prior to construction and continued until rehabilitation of the WWTW and pipeline route has been completed.
- Where concrete is utilised the detrimental impacts of uncured cement on watercourses must be taken into consideration.
- When excavating in watercourses the upper 30 cm, or topsoil, should be removed together with the vegetation and stored as sods on the site. These should then be replaced on top of the installed pipeline.
- Subsoil should be used as backfilling and not as top dressing. Only removed sods and topsoil should be utilised to rehabilitate the bed and bank surface.
- The soil surface should also be re-instated to the virgin soil level and not depressed or elevated as this will promote erosion and cause flow barriers.
- After rehabilitation any excess soil or material should be removed and disposed of at a registered disposal facility.
- Construction through watercourses should be completed in the shortest timeframe to minimise the likelihood of flooding taking place and that no open trenches through watercourses be left for any extended period.
- Where trenches are being excavated through seasonal watercourses this should preferably be done during the winter months when flooding is unlikely to take place.
- Where this is not possible and the main channel experiences active connected flow only half of the channel should be blocked off for construction whilst the remaining half is allowed to maintain flow.
- Adequate monitoring and remediation of erosion should be implemented.

5. Ecological description of affected area

Habitat diversity and species richness:

Habitat diversity at the WWTW and associated pipelines are considered moderate. The area contains a varied topography with hills, ridges, plains and mountains and a high amount of watercourses and wetlands and would therefore have a relatively high habitat diversity under natural conditions. However, as the majority of the development is situated within an urban area this considerably decreases the available habitat diversity. Species diversity was noted to be quite low and may be coupled to the urban environment, high levels of overgrazing and general disturbance caused by the current land use.

Presence of rare and endangered species:

No species of concern, i.e. protected, rare or endangered, occur on the site or the associated pipeline routes. Due to the large-scale transformation and degradation it is also considered unlikely that any such species would occur.

Ecological function:

The ecological function of the WWTW site and associated pipelines has been altered to a large extent. The majority of available habitat has been altered and together with this the ecological function has also been altered to a large degree. Likewise the habitat that these areas would have provided to fauna would therefore also be largely modified. The ecological function of the Kromspruit and associated tributaries is still intact although highly degraded. The flow pattern and ecological functioning of these watercourses should not be further degraded in any way by the proposed WWTW and associated pipelines. The Kromspruit is regarded as sensitive and provide a vital ecological functioning.

Degree of rarity/conservation value:

The vegetation in the area consists of Zastron Moist Grassland (Gm 1) (Map 1). This vegetation type is not currently considered threatened according to the National Environmental Management: Biodiversity Act, 2004 (Act No. 10 of 2004). Furthermore, the majority of this vegetation type within this area has been transformed. As a consequence the vegetation in this area can no longer be considered to be of significant conservation value.

The Kromspruit and associated tributaries are highly degraded but nonetheless still provide a vital ecological function and must therefore be considered to have a high conservation value. The current WWTW is contributing to a large degree to the impacts on the stream. Construction of a new WWTW is anticipated to alleviate these impacts caused by redundant infrastructure.

Percentage ground cover:

Percentage ground cover at the WWTW site and the associated pipeline routes is exceptionally low. This is primarily due to urbanisation and overgrazing.

Vegetation structure:

The dominant vegetation structure consists of grassland although weeds also dominate in many areas. The vegetation structure is considered highly modified. Overgrazing of the area is considered the main cause of this.

Infestation with exotic weeds and invader plants:

Weeds dominate in many areas on the site and associated pipelines (Appendix B).

Degree of grazing/browsing impact:

Grazing and browsing in the area is exceptionally high and has led to a transformation in species composition and vegetation structure.

Signs of erosion:

Erosion on the WWTW site and associated pipelines is very high. This is due to the low vegetation cover which liberates sediments and coupled with increased runoff result in high erosion. As indicated by the description of the affected watercourses this is especially evident along the watercourse channels.

Terrestrial animals:

Due to the degraded condition of the vegetation and habitat on the site and associated pipelines the area is not able to sustain a viable mammal population. It is considered highly unlikely that any species of concern would occur in the area.

Table 6: Biodiversity Sensitivity Rating for the proposed Sterkspruit WWTW and associated pipelines.

	Low (3)	Medium (2)	High (1)
Vegetation characteristics			
Habitat diversity & Species richness	3		
Presence of rare and endangered species	3		
Ecological function			1
Uniqueness/conservation value			1
Vegetation condition			
Percentage ground cover	3		
Vegetation structure	3		
Infestation with exotic weeds and invader plants or encroachers	3		
Degree of grazing/browsing impact	3		
Signs of erosion	3		
Terrestrial animal characteristics			
Presence of rare and endangered species	3		
Sub total	24	0	2
Total		26	

6. Biodiversity sensitivity rating (BSR) interpretation

Table 7: Interpretation of Biodiversity Sensitivity Rating.

Site	Score	Site Preference Rating	Value
Sterkspruit WWTW and pipelines	26	Advanced Degraded	4

7. Discussion and conclusions

The site for the proposed WWTW and associated pipeline network has been rated as being in an advanced state of degradation and was quite evident from the survey. It is therefore evident that the ecological condition is very poor. However, elements of important ecological function and high conservation value do remain and are mostly associated with the Kromspruit and affected tributaries (Map 1 & 2).

The proposed Waste Water Treatment Works (WWTW) will be constructed in the town of Sterkspruit on the banks of the Kromspruit along the northern peripheries of the town (Map 1 & 2). From the WWTW a series of bulk transport pipelines will be constructed to service the urban areas of the town and will include the areas of Sterkspruit, Esilindini, Tapoleng and Mokhesi. The WWTW consists of existing oxidation ponds but without any treatment plant. The extent of the WWTW is approximately 3.6 hectares. The site of the WWTW is therefore already largely transformed although it may still have an impact on the adjacent Kromspruit. The associated pipeline system will be situated within the urban area and although small portions of remaining vegetation is present these are also heavily degraded. The pipelines will however also cross numerous watercourses and wetlands.

According to Mucina & Rutherford (2006) the area consists of Zastron Moist Grassland (Gm 1) (Map 1). This vegetation type is not currently considered threatened according to the National Environmental Management: Biodiversity Act, 2004 (Act No. 10 of 2004). Furthermore, the majority of this vegetation type within this area has been transformed by the urban area and associated disturbances. This results in a significant decrease in the conservation value of any remaining vegetation.

The Eastern Cape Biodiversity Conservation Plan (ECBCP – 2007) has been published in order to identify areas which are essential to meeting conservation targets for specific vegetation types, i.e. Critical Biodiversity Areas. The WWTW and associated pipelines fall almost completely within a Critical Biodiversity Area 1 (CBA 1) as a result of it consisting of Maloti-Drakensberg critically endangered vegetation types (Map 3). However, the survey has confirmed that the development is almost completely situated within the urban area and that any remaining vegetation has also been heavily degraded. As a result, the conservation value will be relatively low.

The area has quite a varied and uneven topography with hills, mountains, ridges, plateaus and plains dominating. The WWTW will be situated on a relatively flat alluvial plain adjacent to the Kromspruit. The river forms a horseshoe bend with the WWTW site located within this bend (Map 2). The WWTW will be situated at an elevation of 1436 m with the surrounding areas which will be serviced by the proposed pipeline network varying but having a maximum elevation of 1543 m. The decrease in altitude from the surrounding pipeline areas toward the WWTW clearly indicate the low lying position of the site and Kromspruit and will allow for gravitational flow, i.e. the location of the WWTW is important to allow for adequate functioning of the pipeline network.

As indicated, the natural vegetation in the area has already been largely transformed by numerous impacts though largely associated with the urban area (Map 1). The WWTW site consists of existing oxidation ponds which has already transformed the majority of the site with remaining vegetation also heavily degraded and dominated by pioneer grasses. It was also noted that the oxidation ponds are leaking into the Kromspruit. The majority of the pipeline route will be situated within the urban area and consequently here the natural vegetation has been mostly removed. Low density urban areas dominate with rural farming activities also being prominent.

Only a few small portions of remaining natural vegetation remain though it was also notable that even these areas are heavily degraded by overgrazing of domestic livestock. The pipeline network will largely follow the existing road network with large sections also situated along the R392 tarred road. Here the road reserve is also largely transformed. From the above it should be evident that the layout of the WWTW and associated pipelines is almost completely situated within transformed areas and should therefore considerably decrease the impact.

From the description of the vegetation on the WWTW site it should be abundantly clear that almost no natural vegetation remain and vegetation currently on the site is dominated by pioneer and exotic species. Overgrazing by domestic livestock is evidently quite high. Due to high levels of disturbance and transformation of the natural vegetation it is also highly unlikely that any species of conservation significance would be present. The proposed development of the WWTW should therefore not result in a significant impact on natural vegetation.

From the description of the vegetation along sections of the pipeline routes still consisting of natural vegetation it is clear that although vegetation remain here it is heavily modified and degraded from the natural condition. Pioneer species dominated and high levels of overgrazing by domestic livestock is evident. As a result of high levels of disturbance, it is considered unlikely that protected or Red Listed species would occur though this probability cannot completely be discounted. The high levels of disturbance and modification of the natural vegetation, low species diversity, the urban surroundings and the low likelihood of species of conservation importance occurring all contribute to decrease the impact that the proposed pipeline network will have.

Signs and tracks of mammals are largely absent from both the WWTW site and the associated pipeline network. This is most likely a result of the urban surroundings, transformation of the remaining natural areas and extensive overgrazing by domestic livestock. Coupled with livestock grazing are also an abundance of herding dogs which would also have a further significant impact on any remaining mammals. As a consequence it is considered highly unlikely that any species of conservation concern would remain in the area. Furthermore, any remaining mammals are considered highly likely to consist of generalist species able to survive in these urban and transformed areas. The impact that the proposed WWTW and associated pipelines will have is mainly concerned with the loss of habitat. However, as previously indicated the habitat which will be affected has already been transformed and degraded to a large extent by the urban environment and associated land uses. Furthermore, the footprint of the development will not be extensive and should therefore limit the impact on mammals.

The WWTW is situated adjacent to the Kromspruit River and final effluent will be discharged into the river (Map 2). In addition, the associated pipeline network will also cross over several watercourses and associated wetlands (Map 1).

Soil samples along the Kromspruit at the WWTW clearly indicate a perennial zone of wetness along the main channel and transition into a seasonal and temporary zone along the lower zone of the river (Map 2). The upper zone or bank of the river is however devoid of wetland conditions though still forming part of the riparian zone (Map 2). Obligate wetland plants along the marginal and lower zones of the river also clearly confirms the presence of wetland conditions here while the upper zone consists exclusively of terrestrial species.

Soil samples indicated that all of the watercourses being crossed by the pipeline network contain wetland conditions. The majority of stream systems have a distinctive main channel and

especially so where wetland conditions occur. Obligate wetland species clearly indicate the presence of wetland conditions in these watercourses.

The Kromspruit as well as watercourses being crossed by the pipeline network are all very similar in their functioning and can all be characterised as channel wetland systems with wetland conditions mainly present along the main channel (SANBI 2009). A few of the watercourses and especially the larger systems also contain a floodplain wetland system (SANBI 2009). This accurately describes the wetland conditions which occurs in the floodplain of a few of the larger watercourses though was absent from the Kromspruit in the vicinity of the WWTW site.

Due to the high number of watercourses being crossed by the pipeline a determination of the Index of Habitat Integrity (IHI) will only be conducted for the perennial Kromspruit which will be affected by the WWTW (Appendix C). The remaining smaller watercourses which will be crossed by the pipeline network all drain in to this system and they therefore form part of the same system being affected by the same impacts and will also impact the same downstream areas. This is considered to give an adequate representation of the overall condition of the Kromspruit affected by the WWTW and watercourses being crossed by the pipeline network. The IHI will be taken as representative of the Present Ecological State (PES) of these systems.

Despite the poor condition of the Kromspruit and associated tributaries being crossed by the pipeline network they should all be considered as sensitive and providing essential services in terms of water transportation and ecological functioning. Furthermore, the Kromspruit is listed as a National Freshwater Ecosystems Priority Areas: Upstream System and forms part of the upstream catchment of the region and therefore plays an important role in water provision. This also substantiates the importance of the river

The Kromspruit and its associated tributaries are affected by numerous activities mostly as a result of the urban area of Sterkspruit. An Index of Habitat Integrity (IHI) was conducted for the Kromspruit. The results of this IHI also indicated that the Kromspruit in the area adjacent to the WWTW has an Instream IHI of category C/D: Moderately to Largely modified and a Riparian IHI of category D: Largely modified. A summary of these results are included in Appendix C.

The EI&S of the Kromspruit and associated tributaries has been rated as being Moderate: Floodplains that are considered to be ecologically important and sensitive on a provincial or local scale. The biodiversity of these floodplains is not usually sensitive to flow and habitat modifications. They play a small role in moderating the quantity and quality of water of major rivers.

Although highly degraded the Kromspruit remains a vital water resource. It is anticipated that the construction of a new WWTW would alleviate the current impacts on the river and should therefore improve its condition.

As previously indicated, though the WWTW will affect the Kromspruit, the proposed pipeline network will also cross several smaller watercourses and wetlands. All of these has been summarised separately within Section 4.3.6 of the report.

Table 8: Summary of watercourses and the position of the pipeline crossings (Map 1 & 2).

Watercourse	Position of crossing
#1 Unnamed drainage line – Tributary of the Kromspruit	S 30.518131°, E 27.379398°
#2 Unnamed stream - tributary of the Kromspruit	S 30.519968°, E 27.379228° S 30.520361°, E 27.378877°
#3 Kromspruit – Bridge crossing	S 30.524390°, E 27.371659°
#4 Unnamed stream – tributary of the Kromspruit.	S 30.543412°, E 27.379140°
#5 Unnamed stream – tributary of the Kromspruit	S 30.529410°, E 27.348249° S 30.535210°, E 27.346717° S 30.544729°, E 27.344046°
#6 Unnamed stream – upstream tributary of #5 stream	S 30.549772°, E 27.338470° S 30.551482°, E 27.327565°
#7 Unnamed stream – tributary of the Kromspruit	S 30.536590°, E 27.316204°
#8 Unnamed drainage line – tributary of stream #5	S 30.533042°, E 27.343020°

Spillages or leakages of sewage from the system into watercourses will cause significant impacts and this should be taken into account in the design, construction and management of the WWTW and associated pipeline network. A comprehensive monitoring programme should be initiated which should focus on the water quality within the Kromspruit adjacent to the WWTW. At least two monitoring points must be established; one upstream and one downstream. These must be analysed on a monthly basis to determine if the WWTW is causing pollution of the Kromspruit. It is also recommended that bi-annual biomonitoring of the Kromspruit be initiated during the construction phase and sustained throughout its operation. This should include SASS5 and IHI indices during the wet- and dry seasons.

During construction the release of sediments and pollutants may occur into the Kromspruit. Likewise, during operation, flooding of the WWTW may contaminate the water within the river. In order to prevent this the footprint of the WWTW should remain outside the border of the upper zone (refer to Map 2). Storm water measures such as berms and cut-off trenches should be designed and implemented in order to keep dirty water within the operational area separate from the water within the Kromspruit. This should also prevent flooding of the WWTW. The Kromspruit and its banks should be treated as a no-go area and no activities either during construction or operation should encroach onto the banks.

The construction of the pipeline network and crossing of watercourses will also result in significant impacts. Although in most instances the pipeline will be constructed as a bridge attachment in these instances the impact will be low. However, installation of the pipeline may still result in the disturbance of the bed and banks of the watercourses. This in turn will promote erosion, prevent the banks from stabilising and lead to increased sedimentation of the watercourses. As a result disturbance of the banks should be kept to a minimum and erosion remediated where it occurs. As indicated in the descriptions of these watercourses, erosion is highly problematic and the implementation of erosion prevention structures may have to be considered. Where steep banks occur and erosion is evidently problematic it is recommended that geotextiles be utilised to stabilise soils. Available options include contouring, berms, gabions and geotextile netting.

8. Recommendations

- After construction of the WWTW and pipeline network the area must be rehabilitated. This includes removal of all construction material. Excavated rock may not be left in heaps and must be removed or distributed evenly over the terrain to represent a natural environment. Compacted areas must be ripped. Construction roads not being utilised afterwards must be rehabilitated.
- Problematic weeds must be eradicated where these establish on the constructed pipeline route (Appendix B). The watercourse crossings especially should be monitored for establishment of weeds.
- The route must be inspected for erosion due to construction. This is particularly relevant where watercourses or slopes are involved. Where erosion is evident this must be remedied.
- No littering must be allowed and all litter must be removed from the site.
- No hunting, harming, capturing or trapping of fauna must be allowed and this must be strictly prohibited.
- Open trenches may act as pitfall traps to mammals, reptiles and amphibians and trenches should be daily monitored for trapped animals which should be removed promptly.
- In the event of poisonous snakes or other dangerous animals encountered on the site an experienced and certified snake handler or zoologist must remove these animals from the site and re-locate them to a suitable area.
- Monitoring of construction and compliance with recommended mitigation measures must take place.
- The following mitigation is recommended where watercourses and wetlands will be affected:
 - The footprint of the WWTW should remain outside the border of the upper zone (refer to Map 2). Storm water measures such as berms and cut-off trenches should be designed and implemented in order to keep dirty water within the operational area separate from the water within the Kromspruit. This should also prevent flooding of the WWTW.
 - The Kromspruit and its banks should be treated as a no-go area and no activities either during construction or operation should encroach onto the banks (Map 2).
 - The disturbance caused by construction will also cause susceptible conditions for further establishment of exotics. It is therefore recommended that weed eradication be initiated at the WWTW and crossing sites prior to construction and continued until rehabilitation of the WWTW and pipeline route has been completed.
 - Where concrete is utilised the detrimental impacts of uncured cement on watercourses must be taken into consideration.

- It is evident that erosion is highly problematic along watercourses in the area. As a result disturbance of the banks should be kept to a minimum and erosion remediated where it occurs.
- Where steep banks occur and erosion is evidently problematic it is recommended that geotextiles be utilised to stabilise soils. Available options include contouring, berms, gabions and geotextile netting.
- When excavating in watercourses the upper 30 cm, or topsoil, should be removed together with the vegetation and stored as sods on the site. These should then be replaced on top of the installed pipeline.
- Subsoil should be used as backfilling and not as top dressing. Only removed sods and topsoil should be utilised to rehabilitate the bed and bank surface.
- The soil surface should also be re-instated to the virgin soil level and not depressed or elevated as this will promote erosion and cause flow barriers.
- After rehabilitation any excess soil or material should be removed and disposed of at a registered disposal facility.
- Construction through watercourses should be completed in the shortest timeframe to minimise the likelihood of flooding taking place and that no open trenches through watercourses be left for any extended period.
- Where trenches are being excavated through seasonal watercourses this should preferably be done during the winter months when flooding is unlikely to take place.
- Where this is not possible and the main channel experiences active connected flow only half of the channel should be blocked off for construction whilst the remaining half is allowed to maintain flow.
- Adequate monitoring and remediation of erosion should be implemented.
- A comprehensive monitoring programme should be initiated and at least two water quality sampling points must be established; one upstream and one downstream. These must be analysed on a monthly basis to determine if the WWTW is causing pollution of the Kromspruit.
- It is also recommended that bi-annual biomonitoring of the Kromspruit be initiated during the construction phase and sustained throughout its operation. This should include SASS5 and IHI indices during the wet- and dry seasons.

9. References

- Bromilow, C. 1995. Problem Plants of South Africa. Briza Publications CC, Cape Town.
- Bromilow, C. 2010. Problem plants and alien weeds of South Africa. Briza Publications CC, Cape Town.
- Child MF, Roxburgh L, Do Linh San E, Raimondo D, Davies-Mostert HT, editors. The 2016 Red List of Mammals of South Africa, Swaziland and Lesotho. South African National Biodiversity Institute and Endangered Wildlife Trust, South Africa.
- Coates-Palgrave, M. 2002. Keith Coates-Palgrave Trees of Southern Africa, edn 3, imp. 4. Random House Struik (Pty.) Ltd, Cape Town.
- Conservation of Agricultural Resources Act, 1983 (ACT No. 43 OF 1983) Department of Agriculture.
- Duthie, A. 1999. Appendix W5: IER (floodplain and wetlands) determining the Ecological Importance and Sensitivity (EIS) and Ecological Management Class (EMC). In: MacKay (Ed.), H. Resource directed measures for protection of water resources: wetland ecosystems. Department of Water Affairs and Forestry, Pretoria.
- Department of Water Affairs and Forestry. 2004. Development of a framework for the assessment of wetland ecological integrity in South Africa. Phase 1: Situation Analysis. by MC Uys. Contributors G Marneweck And P Maseti. Report No. 0000/00/REQ/0904 ISBN No.: 0-621-35474-0. Resource Quality Services, Department of Water Affairs and Forestry, Pretoria, South Africa.
- Department of Water Affairs and Forestry. 2005. A practical field procedure for identification and delineation of wetlands and riparian areas. Edition 1. Department of Water Affairs and Forestry, Pretoria.
- Fish, L., Mashau, A.C., Moeaha, M.J. & Nembudani, M.T. 2015. Identification guide to the southern African grasses. An identification manual with keys, descriptions and distributions. *Strelitzia* 36. South African National Biodiversity Institute, Pretoria.
- Gerber, A., Cilliers, C.J., Van Ginkel, C. & Glen, R. 2004. Easy identification of aquatic plants. Department of Water Affairs, Pretoria.
- Germishuizen, G. & Meyer, N.L. (eds) 2003. Plants of Southern Africa: an annotated checklist. *Strelitzia* 14. National Botanical Institute, Pretoria.
- Gibbs Russell, G.E., Watson, L., Koekemoer, M., Smook, L., Barker, N.P., Anderson, H.M. & Dallwitz, M.J. 1990. Grasses of Southern Africa. Memoirs of the Botanical Survey of South Africa No. 58. Botanical Research Institute, South Africa.
- Government of South Africa. 2008. National Protected Area Expansion Strategy for South Africa 2008: Priorities for expanding the protected area network for ecological sustainability and climate change adaptation. Government of South Africa, Pretoria.

Griffiths, C., Day, J. & Picker, M. 2015. *Freshwater Life: A field guide to the plants and animals of southern Africa*. Penguin Random House South Africa (Pty) Ltd, Cape Town.

Kleynhans, C.J., Thirion, C. and Moolman, J. 2005. A level I River Ecoregional classification system for South African, Lesotho and Swaziland. Report No: N/0000/00/REQ0104. Resource Quality Services, Department of Water Affairs and Forestry, Pretoria, South Africa.

Kleynhans, C.J. 2000. Desktop estimates of the ecological importance and sensitivity categories (EISC), default ecological management classes (DEMC), present ecological status categories (PESC), present attainable ecological management classes (present AEMC), and best attainable ecological management class (best AEMC) for quaternary catchments in South Africa. DWAF report, Institute for Water Quality Studies, Pretoria, South Africa.

Malan, P.W., Venter, H.J.T. & Du Preez, P.J. 1999. Vegetation ecology of the southern Free State: 1. Plant communities of the Zastron area. *South African Journal of Botany*. 65(4): 260-269.

Manning, J. 2009. *Field Guide to Wild Flowers*. Struik Nature, Cape Town.

Marnewecke, G. & Kotze, D. 1999. Appendix W6: Guidelines for delineation of wetland boundary and wetland zones. In: MacKay (Ed.), H. Resource directed measures for protection of water resources: wetland ecosystems. Department of Water Affairs and Forestry, Pretoria.

Moffett, R. 1997. *Grasses of the Eastern Free State: Their description and uses*. UNIQWA, the Qwa-Qwa campus of the University of the North, Phuthaditjhaba.

Mucina, L. & Rutherford, M.C. (eds.) 2006. *The Vegetation of South Africa, Lesotho and Swaziland*. *Strelitzia* 19. South African National Biodiversity Institute, Pretoria.

National Environmental Management: Biodiversity Act (10/2004): National list of ecosystems that are threatened and in need of protection. Government Notice 1002 of 2011, Department of Environmental Affairs.

National Water Act (Act No. 36 of 1998). Republic of South Africa.

Nel, J.L., Murray, K.M., Maherry, A.M., Petersen, C.P., Roux, D.J., Driver, A., Hill, L., Van Deventer, H., Funke, N., Swartz, E.R., Smith-Adao, L.B., Mbona, N., Downsborough, L. and Nienaber, S. (2011). Technical Report for the National Freshwater Ecosystem Priority Areas project. WRC Report No. K5/1801.

Pooley, E. 1998. *A field guide to wild flowers: Kwazulu-Natal and the Eastern Region*. Natal Flora Publications Trust, Durban.

Pooley, E. 2003. *Mountain Flowers: A field guide to the flora of the Drakensberg and Lesotho*. The Flora Publications Trust, Durban.

Raymondo, D. Van Staden, L. Foden, W. Victor, J.E. Helme, N.A. Turner, R.C. Kamundi, D.A. Manyama, P.A. (eds.) 2009. *Red List of South African Plants*. *Strelitzia* 25. South African National Biodiversity Institute, Pretoria.

- Retief, E. & Meyer, N.L. 2017. Plants of the Free State: Inventory and identification guide. *Strelitzia* 38. South African National Biodiversity Institute, Pretoria.
- SANBI. 2009. Further Development of a Proposed National Wetland Classification System for South Africa. Primary Project Report. Prepared by the Freshwater Consulting Group (FCG) for the South African National Biodiversity Institute (SANBI).
- Smithers, R.H.N. 1986a. Land Mammals of Southern Africa. Macmillan, Johannesburg.
- Smithers, R.H.N. 1986b. South African Red Data Book - Terrestrial Mammals. *South African National Scientific Programmes Report No. 125*. A report for the Committee for Nature Conservation Research National Programme for Ecosystem Research.
- Strahler, A.N. 1952. Hypsometric (area-altitude) analysis of erosional topology. *Geological Society of American Bulletin* 63 (11): 1117-1142.
- Van Ginkel, C.E., Glen, R.P., Gordon-Grey, K.D., Cilliers, C.J., Musaya, M. & Van Deventer, P.P. 2011. Easy Identification of some South African Wetland Plants. WRC Report No. TT 479/10.
- Van Oudtshoorn, F. 2004. Gids tot Grasse van Suider-Afrika. Briza Publications, Pretoria.
- Van Wyk, B. & Malan, S. 1998. Field guide to the wild flowers of the Highveld. Struik Publishers, Cape Town.
- Van Wyk, B. & Van Wyk, P. 1997. Field guide to trees of Southern Africa. Struik Publishers, Cape Town.
- Venter, H.J.T. & Joubert, A.M. 1985. Climbers, trees and shrubs of the Orange Free State. P.J. de Villiers Publishers, Bloemfontein.

Annexure A: Maps and Site photos

Locality map for the proposed Waste Water Treatment Works (WWTW) and associated bulk infrastructure pipelines in the town of Sterkspruit, Eastern Cape Province.

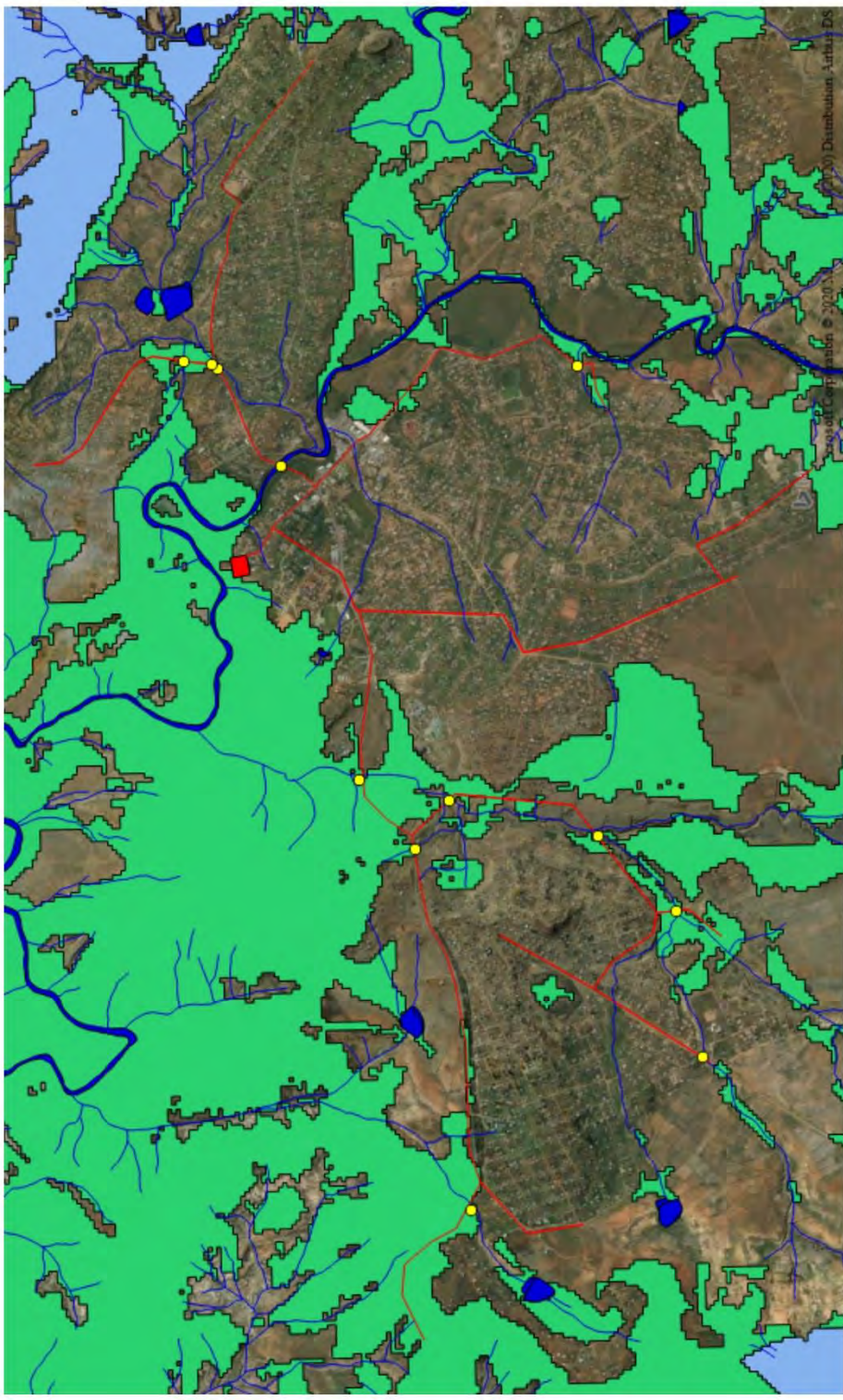

Map 1: Locality map of the proposed WWTW and bulk infrastructure pipeline in Sterkspruit. Note that the majority of the natural vegetation has been transformed with only remnant patches remaining. The major watercourses and the location of crossing points has also been indicated.



Prepared for:
 EKO Environmental
 Suite 227, Private Bag X01
 Brandhof
 9324

Legend:

- Watercourses
- Pipeline route
- Points of crossing
- Wetlands and impoundments
- Zastron Moist Grassland
- Senqu Montane Shrubland

Map Information

Spheroid: WGS 84
 Quantum GIS
Scale: 1:45 000

DPR Ecologists
Contact Darius van Rensburg at:
 danius@dprecologists.co.za
 P.O. Box 12726, Brandhof, 9324
 Tel: 083 410 0770





Wetland delineation map for the proposed Waste Water Treatment Works (WWTW) in the town of Sterkspruit, Eastern Cape Province.



Map 2: Wetland delineation map of the proposed WWTW in Sterkspruit. The location of the existing WWTW and oxidation ponds are visible. Note that it is located in a horseshoe bend formed by the Kromspruit. Wetland conditions are present along the marginal and lower zones of the river while the upper zone still contains the riparian zone of the river. The construction footprint of the WWTW should be retained outside the riparian zone.



Prepared for:
EKO Environmental
Suite 227, Private Bag X01
Brandhof
9324

Legend:



Map Information

Spheroid: WGS 84

Quantum GIS

Scale: 1:5 000

DPR Ecologists
Contact Darius van Rensburg at:
darius@dprecologists.co.za
P.O. Box 12726, Brandhof, 9324
Tel: 083 410 0770





Eastern Cape Biodiversity Conservation Plan (ECBCP) map for the proposed Waste Water Treatment Works (WWTW) and associated bulk infrastructure pipelines in the town of Sterkspruit, Eastern Cape Province.

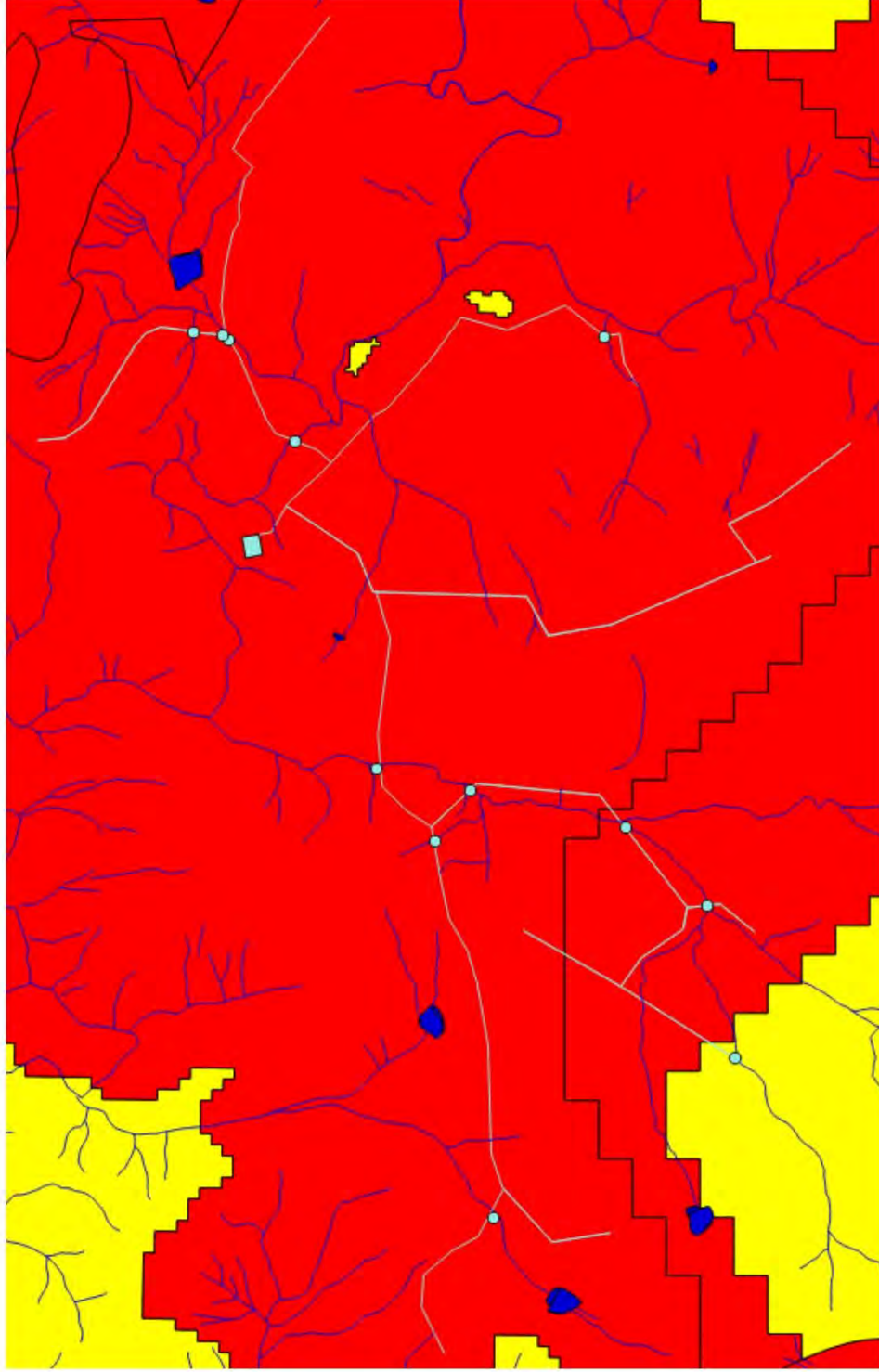

Prepared for:
EKO Environmental
Suite 227, Private Bag X01
Brandhof
9324

Legend:

- Watercourses
- Pipeline route
- Points of crossing
- Wetlands and impoundments
- Critical Biodiversity Area 1
- Critical Biodiversity Area 2
- Critical Biodiversity Area 3

Map Information

Spheroid: WGS 84

Quantum GIS

Scale: 1:45 000

DPR Ecologists

Contact Darius van Rensburg at:

darius@dprecologists.co.za

P.O. Box 12726, Brandhof, 9324

Tel: 083 410 0770



Map 3: ECBCP map of the proposed WWTW and bulk infrastructure pipeline in Sterkspruit. Note that the area is considered a Critical Biodiversity Area 1 (CBA 1) due to it being situated in the endangered Drakensberg-Maloti area. However, available data as well as the on-site surveys confirmed that natural vegetation within this area has almost completely been transformed.

Appendix B: Species list

Species indicated with an * are exotic.

Protected species are coloured orange and Red Listed species red.

Species	Growth form
* <i>Agave americana</i>	Succulent
* <i>Anthemis cotula</i>	Herb
* <i>Argemone ochroleuca</i>	Herb
* <i>Bidens bipinnata</i>	Herb
* <i>Oenothera rosea</i>	Herb
* <i>Oenothera stricta</i>	Herb
* <i>Opuntia ficus-indica</i>	Succulent
* <i>Oxalis corniculata</i>	Geophyte
* <i>Papaver aculeatum</i>	Herb
* <i>Pennisetum clandestinum</i>	Grass
* <i>Plantago lanceolata</i>	Herb
* <i>Pseudognaphalium luteo-album</i>	Herb
* <i>Rosa rubiginosa</i>	Shrub
* <i>Schkuhria pinata</i>	Herb
* <i>Sonchus oleraceus</i>	Herb
* <i>Tagetes minuta</i>	Herb
* <i>Verbena tenuisecta</i>	Herb
<i>Amphiglossa triflora</i>	Dwarf shrub
<i>Aristida congesta</i>	Grass
<i>Aristida junciformis</i>	Grass
<i>Artemisia afra</i>	Shrub
<i>Atriplex semibaccata</i>	Herb
<i>Barleria macrostegia</i>	Herb
<i>Berula erecta</i>	Herb
<i>Centella asiatica</i>	Herb
<i>Cheilanthes eckloniana</i>	Fern
<i>Chrysocoma ciliata</i>	Dwarf shrub
<i>Conyza podocaphala</i>	Herb
<i>Crassula natans</i>	Succulent
<i>Cynodon dactylon</i>	Grass
<i>Cyperus marginatus</i>	Sedge
<i>Cyperus sp.</i>	Sedge
<i>Digitaria eriantha</i>	Grass
<i>Diospyros lycioides</i>	Shrub
<i>Equisetum ramosissimum</i>	Fern
<i>Eragrostis lehmanniana</i>	Grass
<i>Felicia fillifolia</i>	Dwarf shrub
<i>Felicia muricata</i>	Dwarf shrub
<i>Gazania krebsiana</i>	Herb
<i>Gomphostigma virgatum</i>	Dwarf shrub

<i>Hermannia depressa</i>	Herb
<i>Hyparrhenia hirta</i>	Grass
<i>Jamesbrittenia aurantiaca</i>	Herb
<i>Juncus rigidus</i>	Rush
<i>Leptochloa fusca</i>	Grass
<i>Lycium cinerium</i>	Dwarf shrub
<i>Medicago laciniata</i>	Herb
<i>Melolobium sp.</i>	Dwarf shrub
<i>Moraea pallida</i>	Geophyte
<i>Paspalum distichum</i>	Grass
<i>Passerina montana</i>	Shrub
<i>Pentzia incana</i>	Dwarf shrub
<i>Persicaria lapathifolia</i>	Herb
<i>Salvia stenophylla</i>	Herb
<i>Salvia verbenaca</i>	Herb
<i>Searsia burchellii</i>	Shrub
<i>Searsia erosa</i>	Shrub
<i>Selago albida</i>	Dwarf shrub
<i>Senecio consanguineus</i>	Herb
<i>Sporobolus africanus</i>	Grass
<i>Stoebe plumosa</i>	Dwarf shrub
<i>Tragus koelerioides</i>	Grass
<i>Tribulus terrestris</i>	Herb
<i>Trifolium burchellianum</i>	Herb
<i>Typha capensis</i>	Bulrush

Appendix D: Index of Habitat Integrity (IHI) Summary

ASSESSMENT UNIT INFORMATION	
ASSESSMENT UNIT INFORMATION	Sterkspruit WWTW
UPPER LATITUDE	S 30.518920
UPPER LONGITUDE	E 27.367770
UPPER ALTITUDE	1438m
LOWER LATITUDE	S 30.517934
LOWER LONGITUDE	E 27.36666
LOWER ALTITUDE	1436m
SURVEY SITE (if applicable)	Kromspruit
SITE LATITUDE (if applicable)	
SITE LONGITUDE (if applicable)	
SITE ALTITUDE (if applicable)	
WMA	Upper Orange
QUATERNARY	D12B
ECOREGION 2	15_2
DATE	13/10/2020
RIVER	Kromspruit
TRIBUTARY	
PERENNIAL (Y/N)	Y
GEOMORPH ZONE	FOOTHILL
WIDTH (m)	>15

METRIC GROUP	RATING	CONFIDENCE
HYDROLOGY MODIFICATION	1.5	2.0
PHYSICO-CHEMICAL MODIFICATION	2.6	3.0
BED MODIFICATION	2.5	4.0
BANK MODIFICATION	2.0	3.0
CONNECTIVITY MODIFICATION	2.0	4.0
INSTREAM IHI%	57.6	
CATEGORY	C/D	
CONFIDENCE	3.2	

HABITAT INTEGRITY CATEGORY	DESCRIPTION	RATING
		(% OF TOTAL)
A	Unmodified, natural.	90-100
B	Largely natural with few modifications. A small change in natural habitats and biota may have taken place but the ecosystem functions are essentially unchanged.	80-89
C	Moderately modified. Loss and change of natural habitat and biota have occurred, but the basic ecosystem functions are still predominantly unchanged.	60-79
D	Largely modified. A large loss of natural habitat, biota and basic ecosystem functions has occurred.	40-59
E	Seriously modified. The loss of natural habitat, biota and basic ecosystem functions is extensive.	20-39
F	Critically / Extremely modified. Modifications have reached a critical level and the system has been modified completely with an almost complete loss of natural habitat and biota. In the worst instances the basic ecosystem functions have been destroyed and the changes are irreversible.	0-19

METRIC GROUP	RATING	CONFIDENCE
HYDROLOGY	1.91	3.00
BANK STRUCTURE MODIFICATION	3.50	4.00
CONNECTIVITY MODIFICATION	2.30	4.00
RIPARIAN HABITAT INTEGRITY (%)	45.95	
CATEGORY	D	
CONFIDENCE	3.67	

HABITAT INTEGRITY CATEGORY	DESCRIPTION	RATING
		(% OF TOTAL)
A	Unmodified, natural.	90-100
B	Largely natural with few modifications. A small change in natural habitats and biota may have taken place but the ecosystem functions are essentially unchanged.	80-89
C	Moderately modified. Loss and change of natural habitat and biota have occurred, but the basic ecosystem functions are still predominantly unchanged.	60-79
D	Largely modified. A large loss of natural habitat, biota and basic ecosystem functions has occurred.	40-59
E	Seriously modified. The loss of natural habitat, biota and basic ecosystem functions is extensive.	20-39
F	Critically / Extremely modified. Modifications have reached a critical level and the system has been modified completely with an almost complete loss of natural habitat and biota. In the worst instances the basic ecosystem functions have been destroyed and the changes are irreversible.	0-19

	MRU				MRU
INSTREAM IHI				RIPARIAN IHI	
Base Flows	1.5			Base Flows	1.5
Zero Flows	-1.0			Zero Flows	-1.0
Floods	2.5			Moderate Floods	2.5
HYDROLOGY RATING	1.5			Large Floods	2.5
pH	2.5			HYDROLOGY RATING	1.9
Salts	2.5			Substrate Exposure (marginal)	2.0
Nutrients	2.5			Substrate Exposure (non-marginal)	3.0
Water Temperature	2.5			Invasive Alien Vegetation (marginal)	2.0
Water clarity	3.0			Invasive Alien Vegetation (non-marginal)	4.0
Oxygen	3.0			Erosion (marginal)	3.0
Toxics	2.5			Erosion (non-marginal)	3.0
PC RATING	2.6			Physico-Chemical (marginal)	2.5
Sediment	2.5			Physico-Chemical (non-marginal)	0.5
Benthic Growth	2.5			Marginal	3.0
BED RATING	2.5			Non-marginal	4.0
Marginal	2.0			BANK STRUCTURE RATING	3.5
Non-marginal	2.0			Longitudinal Connectivity	2.5
BANK RATING	2.0			Lateral Connectivity	2.0
Longitudinal Connectivity	2.0			CONNECTIVITY RATING	2.3
Lateral Connectivity	2.0				
CONNECTIVITY RATING	2.0			RIPARIAN IHI %	45.9
				RIPARIAN IHI EC	D
INSTREAM IHI %	57.6			RIPARIAN CONFIDENCE	3.7
INSTREAM IHI EC	C/D				
INSTREAM CONFIDENCE	3.2				

**Phase 1 Heritage Impact Assessment of the proposed
new construction of a new Waste Water Treatment
Works (WWTW) and associated pipe line infrastructure
in the town of Sterkspruit, EC Province.**



Report prepared for:
EKO Environmental Consultants
21 Dromedaris Street, Dan Pienaar, Bloemfontein 9301

by

Paleo Field Services
PO Box 38806
Langenhovenpark
9330

Executive Summary

At the request of Eko Environmental Consultants a Phase 1 Heritage Impact Assessment was carried out for the three-phase construction of a new Waste Water Treatment Works (WWTW) and associated pipeline infrastructure in the town of Sterkspruit in the Eastern Cape Province. A pedestrian survey revealed no evidence of *in situ* Stone Age archaeological material, capped or distributed as surface scatters on the landscape. There are also no indications of rock art, prehistoric structures or historical buildings older than 60 years within the vicinity of the study area. It is unlikely that the proposed development will result in any significant archaeological impact along the demarcated footprints. The proposed pipeline routes are regarded as of low archaeological significance and are assigned the rating of Generally Protected C (GP.C).

The palaeontological significance of the sedimentary bedrock at Sterkspruit is considered high and the nature of the proposed development suggests possible impact on potentially fossil-bearing Stormberg Group strata. It is considered likely that fossil remains may be encountered during excavation of sedimentary bedrock within the proposed pipeline and pump station footprints for Phase 1, 2, and 3. However, fossils are not evenly distributed in their occurrence in sedimentary strata so the probability of palaeontological impact resulting from a linear development of this scale may not be as high. The sedimentary bedrock component at Sterkspruit is rated Generally Protected A (GP.A). An investigation of alluvial deposits of the Kromspruit and associated tributaries indicates that impact on potential palaeontological heritage resources within the overlying Quaternary soils is unlikely. The palaeontological significance of the unconsolidated Quaternary soils is therefore considered as low. The superficial sediment component at Sterkspruit is rated Generally Protected C (GP.C).

Table of Contents

Executive Summary	2
Introduction.....	4
Terms of Reference.....	4
Methodology	4
Description of the Affected Area	4
Locality data.....	4
Background	5
Palaeontology.....	5
Archaeology	5
Field Assessment	6
Phase 1	6
Phase 2	6
Phase 3	6
Impact Statement	7
Recommendation	7
References.....	8
Tables and Figures	9

Introduction

At the request of Eko Environmental Consultants a Phase 1 Heritage Impact Assessment was carried out for the three-phase construction of a new Waste Water Treatment Works (WWTW) and associated pipeline infrastructure in the town of Sterkspruit in the Eastern Cape Province (**Fig. 1**). The study is required in terms of Section 38 of the National Heritage Resources Act 25 of 1999 as a prerequisite for any development which will change the character of a site exceeding 5 000 m² in extent or new linear development exceeding 300 m in length. The task involved identification and mapping of possible archaeological heritage within the proposed project area, an assessment of their significance, related impact by the proposed development and recommendations for mitigation where relevant.

Terms of Reference

- Identify and map possible heritage sites and occurrences using available resources.
- Determine and assess the potential impacts of the proposed development on potential heritage resources;
- Recommend mitigation measures to minimize potential impacts associated with the proposed development.

Methodology

The heritage significance of the affected area was evaluated through a desktop study and carried out on the basis of existing field data, database information and published literature. This was followed by a field assessment by means of a pedestrian survey. A Garmin Etrex Vista GPS hand model (set to the WGS 84 map datum) and a digital camera were used for recording purposes. Relevant archaeological and palaeontological information, aerial photographs and site records were consulted and integrated with data acquired during the on-site inspection. The study area is rated according to field rating categories as prescribed by SAHRA (**Table 1**).

Description of the Affected Area

Locality data

1 : 50 000 scale topographic map: 3027CB Sterkspruit

1 : 250 000 scale geological map 3026 Aliwal North

The study area is located within the town of Sterkspruit. The proposed footprint is primarily located within commercial and residential areas (**Fig. 2**).

Background

Palaeontology

Sterkspruit lies within the outcrop area of the Molteno Formation (Stormberg Group). The Molteno Formation overlies the Beaufort Group and consists of a sequence of coarse-grained sandstone and mudstone that was deposited in a braided river, fluvial environment. This formation contains an extremely rich fossil flora, silicified woods and palynomorphs (MacRae, 1999; McCarthy and Rubidge, 2005). Apart from important insect fauna, animal fossils are very sparse, including rare fish, conchostracans, bivalves as well as invertebrate trace fossils and dinosaur tracks. Rare trackways do provide some of the earliest indirect evidence for the first dinosaurs to appear in the South African fossil record (MacRae, 1999; McCarthy and Rubidge, 2005). The Elliot Formation consists of a sequence of red mudstone and subordinate sandstone that was deposited in an arid, braided river and playa lake environment. The formation contains one of the richest Late Triassic to Early Jurassic dinosaur faunas in the world, containing key data on early diversification of the dinosaurs. Several important new dinosaur taxa have recently been discovered in the Free State, including early dinosaurs, ornithischians, rare theropods and crocodylomorphs as well as rare amphibians, turtles, fish, advanced mammal-like reptiles and early mammals. Other fossil elements include petrified wood insects and trace fossils (MacRae, 1999; McCarthy and Rubidge, 2005). The lower Elliot Formation is associated with the Late Triassic aged “Euskelesaurus” Range Zone, whilst the upper Elliot Formation is associated with the Early Jurassic *Massospondylus* Range Zone.

There is currently no record of Quaternary fossil localities in the vicinity of Sterkspruit.

Archaeology

The archaeological footprint of the region is largely represented by rock art sites, Stone Age cave deposits and open sites. Rock paintings are numerous in the region, but are primarily restricted to sandstone cliffs, caves and overhangs. Rock paintings

have been recorded at a number of cave sites between Sterkspruit and Herschel (Van Riet Lowe 1941).

Field Assessment

Phase 1

The WWTW site is underlain by a thick mantle of Quaternary to recent superficial deposits that has been disturbed by previous construction activities (**Fig. 3**). A small farm cemetery is located at the entrance to the existing WWTW (**Fig. 4**). The footprint of the proposed gravity and pump lines are underlain by Stormberg Group sediments capped by shallow to deep superficial deposits of varying depth. The pipelines are located next to existing tar and gravel roads within the commercial and residential area of the town (**Fig. 5**).

There is no above-ground evidence of intact or capped Stone Age or prehistoric archaeological material within the confines of the footprint for the new WWTW and associated pipelines. There are no indications of prehistoric structures, rock art sites or historically significant structures older than 60 within the Phase 1 footprint area.

Phase 2

The footprint of the proposed pump station, pump and gravity lines is located next to existing tar and gravel roads within the commercial and residential area of the town (**Fig. 6 & 7**). The proposed route is underlain by Stormberg Group outcrop and geologically recent superficial deposits. No fossils were observed within exposed bedrock outcrop covered by the footprint. There is no above-ground evidence of intact or capped Stone Age or prehistoric archaeological material within the confines of the Phase 2 footprint. There are no indications of prehistoric structures, rock art sites or historically significant structures older than 60 within the Phase 1 footprint area.

Phase 3

The pump station site is located on Quaternary to recent superficial deposits. The associated pipeline footprint is located next to existing tar and gravel roads within the commercial and residential area of the town (**Fig. 8**). No fossils were observed within exposed bedrock outcrop covered by the footprint. There is no above-ground evidence of intact or capped Stone Age or prehistoric archaeological material within the

confines of the Phase 3. There are no indications of prehistoric structures, rock art sites or historically significant structures older than 60 within the Phase 3 footprint area.

Impact Statement

The palaeontological significance of the sedimentary bedrock at Sterkspruit is considered high and the nature of the proposed development suggests possible impact on potentially fossil-bearing Stormberg Group strata. It is considered likely that fossil remains may be encountered during excavation of sedimentary bedrock within the proposed pipeline and pump station footprints for Phase 1, 2, and 3. However, fossils are not evenly distributed in their occurrence in sedimentary strata so the probability of palaeontological impact resulting from a linear development of this scale may not be as high. The sedimentary bedrock component at Sterkspruit is rated Generally Protected A (GP.A).

An investigation of alluvial deposits of the Kromspruit and associated tributaries indicates that impact on potential palaeontological heritage resources within the overlying Quaternary soils is unlikely. The palaeontological significance of the unconsolidated Quaternary soils is therefore considered as low. The superficial sediment component at Sterkspruit is rated Generally Protected C (GP.C).

It is unlikely that the proposed development will result in any significant archaeological impact along the demarcated footprints. The terrain is regarded as of low archaeological significance and is assigned the rating of Generally Protected C (GP.C).

Recommendation

Sterkspruit is underlain by palaeontologically significant Stormberg Group sediments, and any damage to, or loss of fossils due to inadequate mitigation would be a highly negative palaeontological impact. On the other hand, exposure as a result of excavation and subsequent reporting of fossils could be seen as a positive palaeontological impact provided that SAHRA is notified immediately.

The graveyard located at the WWTW site should be fenced off and included into the development management plan as a no-go zone. The site must be strictly avoided.

References

- Groenewald, G.H. and Groenewald, D. 2013. Palaeontological heritage in the Free State. SAHRA Palaeotechnical Report.
- MacRae, C. 1999. *Life Etched in Stone*. Fossils of South Africa. The Geological Society of South Africa, Johannesburg.
- McCarthy, T. and Rubidge, B.S. 2005. *The Story of Earth and Life*. Struik Publishers, Cape Town.
- Kitching, J.W. Kitching & Raath, M.A. 1984. Fossils from the Elliot and Clarens Formations of the Northeastern Cape, Orange Free State and Lesotho, and a suggested biozonation based on tetrapods. *Palaeontologia africana* 25: 111 – 125.
- Kitching, J.W. 1977. *The distribution of the Karoo Vertebrate fauna*. BPI Memoir 1. University of the Witwatersrand.
- Van Riet Lowe, C. 1941. *Prehistoric Art in South Africa*. Archaeological Series No. V. Bureau of Archaeology, Dept. of the Interior. Pretoria.

Tables and Figures

Table 1. Field rating categories as prescribed by SAHRA.

Field Rating	Grade	Significance	Mitigation
National Significance (NS)	Grade 1	-	Conservation; national site nomination
Provincial Significance (PS)	Grade 2	-	Conservation; provincial site nomination
Local Significance (LS)	Grade 3A	High significance	Conservation; mitigation not advised
Local Significance (LS)	Grade 3B	High significance	Mitigation (part of site should be retained)
Generally Protected A (GP.A)	-	High/medium significance	Mitigation before destruction
Generally Protected B (GP.B)	-	Medium significance	Recording before destruction
Generally Protected C (GP.C)	-	Low significance	Destruction

Table 2. Features and localities recorded during the foot survey.

Feature	Coordinates
Phase 1 WWTW	30°31'6.88"S 27°22'0.85"E
Phase 2 Pump station	30°32'4.98"S 27°20'39.27"E
Phase 3 Pump station	30°31'23.17"S 27°22'18.08"E
Cemetery	30°31'10.08"S 27°21'56.26"E
Bridge	30°32'11.57"S 27°18'58.39"E

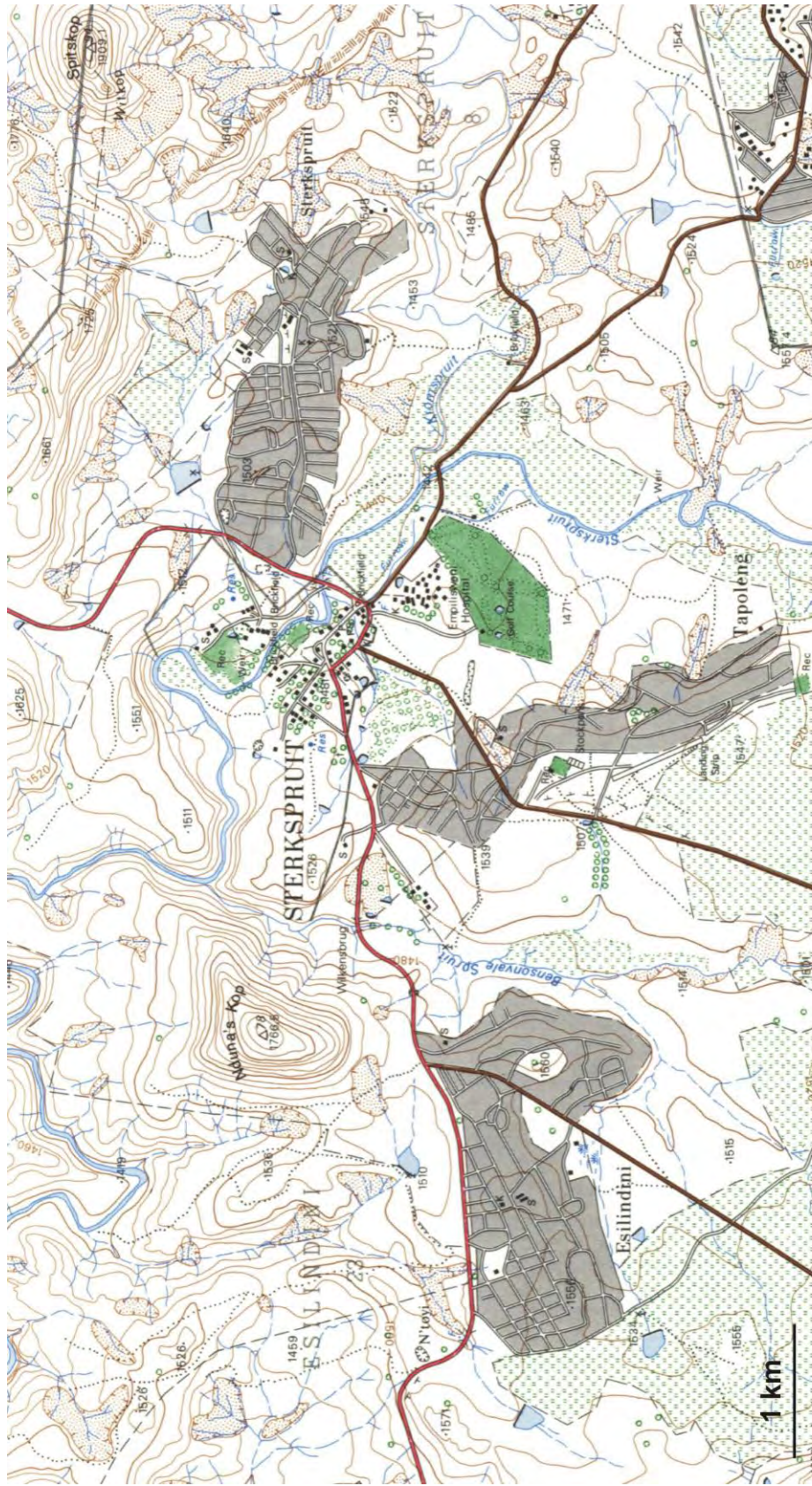

Figure 1. Map of Sterkspruit (portion of 1:50 000 topographical map 3027CB Sterkspruit)



NEW BULK CONNECTOR LAYOUT

ANNEXURE - E

Figure 2. Layout of the proposed development.



Figure 3. The WWTW site looking north (above) and overbank (alluvial) deposits of the Kromspruit at the WWTW site, looking southwest (below).



Figure 4. Small graveyard located near the entrance to the proposed new WWTW site.



Figure 5. Phase 1 pipeline route



Figure 6. Phase 2 pipe line route.

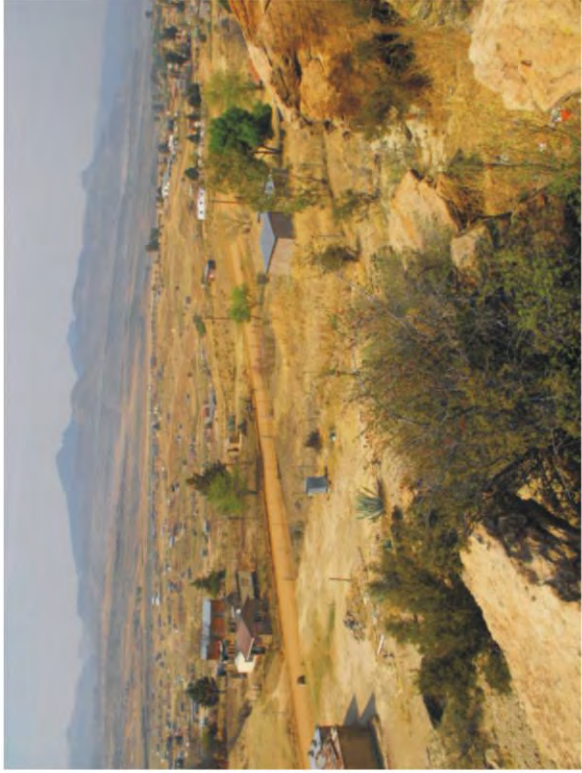
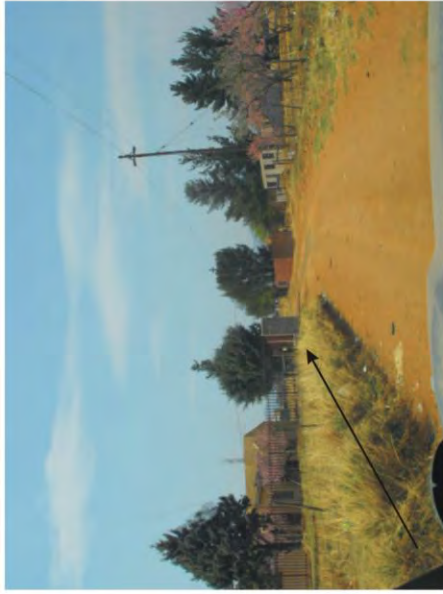

Figure 7. Phase 2 pipe line route.



Figure 8. Phase 3 pipe line route.

info@ekogroup.co.za
t • +27(0)51 444 4700
f • +27(0)86 697 6132
Suite 158 • Private Bag X01
BRANDHOF 9324
21 Dromedaris Street
Dan Pienaar
BLOEMFONTEIN 9301



**Ground- and Surface Water Assessment for the
establishment of a waste water treatment plant on
the remainder of Erf 1, Sterkspruit**

Jan 2015

Project Team:

Gys Hoon, B. Sc. Hons. Pr.Sci.Nat, Geohydrology

DECLARATION OF INDEPENDENCE

Eco Environmental is an independent company and has no financial, personal or other interest in the proposed project, apart from fair remuneration for work performed in the delivery of hydrogeological services. There are no circumstances that compromise the objectivity of the study.

Report Version	Final 1.0		
Title	Ground- and Surface Water Assessment for the establishment of a waste water treatment plant on the remainder of Erf 1, Sterkfontein		
Author	Gys Hoon		Jan'15

Table of Contents**Contents**

1	Introduction	4
1.1	Background	4
1.2	Scope of Work	4
1.3	Methodology	6
2	Surface Water	6
3	Geology	7
4	Groundwater	8
4.1	Groundwater occurrence:	8
	Groundwater Quality:	8
	Potential Impacts	8
5	Conclusion	9
6	Recommendations	9
7	Annexure -	10

1 INTRODUCTION

1.1 Background

The existing sewage treatment facility for the Sterkspruit area is an oxidation ponds system linked with a temporary package plant located on the banks of the Kromspruit River. The facility is situated within a bend in the Kromspruit and is situated between 20 and 30 meters from the river. The existing maturation ponds are not lined with clear evidence on the banks of the stream that water is seeping into the spruit. There are no evidence of a constant overflow into the spruit, but it is very likely that discharge to the spruit occurred in the pass especially during high rainfall events.

The new proposed WWTW will be situated on the same site (Remainder of Erf 1), and next to the existing facility. The natural habitat in the area is highly degraded and transformed.

The area around the maturation ponds were used in the past for the irrigation of fodder with the final effluent from the last maturation pond.

1.2 Scope of Work

It is proposed to upgrade the facility to treat 2 Ml The facility which will be sufficient for 5 years from start-up After the 5 year period the facility will be expanded to treat a total inflow of 6 Ml/day. The final effluent will comply with the general wastewater limits as defined in the revision of the General Authorisations In Terms Of Section 39 of The National Water Act, 1998 (Act No. 36 Of 1998) of 6 September 2013.

Wastewater limits for final effluent from the sewage treatment plant

Faecal Coliforms (per 100 ml)	1000
Chemical Oxygen Demand (COD) (mg/l)	75
ph	5.5-9.5
Ammonia (ionised and un-ionised) as Nitrogen (mg/l)	6
Nitrate/Nitrite as Nitrogen (mg/l)	15
Chlorine as Free Chlorine (mg/l)	0.25

Suspended Solids (mg/l)	25
Ortho-Phosphate as phosphorous (mg/l)	10

The main objective will be to re-use as much of the water for irrigation of fodder, town gardens and sport fields. It is however unlikely that all the effluent will be irrigated and it will necessary to discharge the balance into the Kromspruit. The available area that was previously used to irrigate the final effluent is approximately 3 ha and located around the existing maturation ponds as indicated below in figure 1:



Figure 1: Existing maturation ponds with the surrounding areas where the final effluent was previously irrigated.

The existing infrastructure, piping, pumps and sprayers are not operational at the moment.

It is estimated that approximately 82 000 litre (82 m³) can be irrigated on the available land based on an available area for irrigation of 3 ha and a capacity to irrigate 1000 mm/annum.

1.3 Methodology

- Desktop assessment of all available: water quality data, geological maps, geohydrological information and maps, areal images etc.
- On-site assessment, borehole census in a 1 km radius of the site, once off sampling of surface water bodies and measurements of available ground water levels.

2 SURFACE WATER

The proposed mine site falls within the D12A quaternary drainage area within the Upper Orange Water Management Area. The Kromspruit is a tributary of the Orange River with its confluence approximately 60 km (linear distance) upstream of Aliwal North. The Sterkspruit sewage treatment plant is located approximately 6 km (linear distance) south-east of the Kromspruit-Orange River confluence.

The average rainfall in the area is between 600-700 mm per annum which occurs largely as thunderstorms between November and April. The surface water runoff in the area is typically restricted to very high rainfall events with an estimate mean annual runoff of between 100 – 200 mm per annum (Water Resources of South Africa, 2005 Study, WR2005)

The Sterkspruit Sewage Treatment Plant (**STP**) is located on the banks of the Kromspruit and downstream of Sterkspruit town. The water quality in the Kromspruit is impacted by the runoff from various small rural areas and townships in the upper reaches of the D12A catchment upstream of the STP. There are no heavy industries, intensively irrigated agricultural activities or mines that may impact on the water quality or river health of the Kromspruit.

2.1 Water quality:

The water in the Kromspruit was sampled upstream and downstream of the Sterkspruit STP on 14 Sep'14 to assess existing water quality status (see water quality data in Appendix A). The monitoring was focussed on the relevant parameters that relates to the impact from urban runoff and the handling of sewage. The electric conductivity upstream and downstream of the site is very low with an average of 40 mS/m and in terms of this render the water a Class 1 in terms of the South African National Standards (SANS) 241:2006 & 20011 for drinking water. The relative high counts of E.coli and Faecal coliforms however indicate that raw untreated sewage is entering the system. The pathways of sewage contamination are currently poorly

reticulated residential areas, blockages and seepage from the existing maturation ponds into the spruit.

There are no comprehensive water quality data available in the Kromspruit as identified in the Orange River: Assessment of Water Quality Data Requirements for Water Quality Planning Purposes, 2009. In the report it was indicated that a national water quality monitoring point needs to be established at Sterkspruit. The main concern in the Orange River basin is soil erosion, sediment transport and siltation of downstream dams.

2.2 Potential impact:

The Sterkspruit STP may impact on the water quality in the Kromspruit along the following pathways:

- The discharge of final effluent into the Kromspruit will have an impact on the downstream water quality as it will be virtually impossible to treat sewage water that it comply with pristine water quality objectives in the upper reaches of the Kromspruit.
- Seepage from the maturation ponds

2.3 Mitigation:

- The plant should be designed and operated in manner that the final effluent comply with the general limits in Terms Of Section 39 of The National Water Act, 1998 (Act No. 36 Of 1998) of 6 September 2013
- The maturation ponds need to be upgraded in a manner that there is no seepage.
- The re-use of the final effluent to irrigate fodder, town gardens and sports fields should be maximised to reduce the total volumes that will be discharged.

3 GEOLOGY

The geology of the area is consisting mainly of the sedimentary deposits of the Karoo Super Group. The underlying formations consist of sedimentary deposits of sandstone, mudstone and shales of the Molteno formation. The Karoo formations have been intersected by dolomite sills and dykes which normally manifested as ridges or koppies because the higher resistance against natural weathering in relation to the surrounding sandstone, mudstone and shale sedimentary rocks of the Moteno.

4 GROUNDWATER

4.1 Groundwater occurrence:

Groundwater occurs as inter-granular and/or fractured zone aquifers. There are no high yield aquifers in a 1 km radius of the site that are developed. Groundwater is mainly used for livestock watering and domestic use where no surface water resources are available and that is not serviced by means of the local water reticulation network. The average yield of boreholes in the area is between 0.1 and 0.5 l/s.

There are no significant fountains in the area (1 km radius).

There are no production boreholes with a 1 km radius of the site.

4.2 Groundwater Quality:

There were no equipped boreholes in a 1 km radius that could be sampled or to determine the regional groundwater depth. .

4.3 Potential Impacts

The main concern in terms of the risk on ground water resources from a sewage treatment plant will be the risk that contaminated water seep from the facility and enter the ground water regime along potential preferential pathways. These pathways are normally fractured zones along faults or dolerite intrusions.

The existing maturation ponds could have had an impact on groundwater because of the historic existence of the facility and the prolonged seepage. The visible seepage along the banks of the spruit from the ponds indicates however that an impermeable or partially impermeable layer underlays the facility that created a preferential pathway for the movement of seepage. Water that seeps from the facility migrates along this feature to enter the spruit.

There are no evidence of extensive abstraction of groundwater within a 1 km radius of the facility and therefore no threat to any users.

4.4 Mitigation:

- The upgrade of the maturation ponds should include the lining thereof to prevent potential seepage.
- The irrigation of final effluent should be done in a manner that no pooling occurs.
- The quality of the final effluent should comply with the general limits.

5 CONCLUSION

The Kromspruit is a tributary of the Orange River and contribute to the water demand needs of many water users along the Orange River. There is no continuous water quality available on the national water quality database that is managed by the Department of Water and Sanitation. In a recent assessment of the Orange River basin it was recommended that a national water monitoring point should be established at Sterkfontein.

There or no significant abstraction from the Kromspruit between Sterkspruit and its confluence with Orange River.

From the once-off water quality date and a visual assessment of the river status it is clear that the spruit are affected by sub-standard water from sewage origin enter the system. This is mainly overflows as a result of overflow from sewage blockages, runoff from poorly reticulated areas and the seepage from the existing maturation ponds.

The upgrade of the Sterkfontein STP will have a significant positive impact on the general river health in the Kromspruit.

6 RECOMMENDATIONS

- During the construction phase with the clearance of vegetation care should be taken to divert upstream runoff around work areas during rain event to prevent unnecessary erosion.
- Storage of fuel and oil should be done according to best practices to prevent contamination of run-off.
- All waste must be stored according to best practices and disposed at an authorized waste disposal facility.
- Toilet facilities must be made available on site and maintained.

- The design of the facility and operational procedures should be done in manner to ensure compliance to the general wastewater limits as defined in the revision of the General Authorisations In Terms Of Section 39 of The National Water Act, 1998 (Act No. 36 Of 1998) of 6 September 2013.
- The irrigation of the final effluent can be considered an existing lawful use as this was practiced before the promulgation of the National Water Act'1998.
- The re-use of final effluent should also be maximized to support the national objectives to conserve natural resources.
- The discharge of the final effluent into the Kromspruit can also be considered as a general authorization for a volume up to a 2000 m³ (2 MI) any given day on condition that it complies with the general limits for waste water quality.
- The proposal also includes an additional upgrade in year 5 from the commissioning of the facility to a capacity of 6 MI/day. The water use license application should therefore include an authorization for the discharge of final effluent up to 6 MI/day.
- The storage and disposal of grid from the inlet works should be done according to best practices to prevent contamination of runoff and soil.
- The disposal of sludge should be done according to The Guideline for Permissible Utilisation and Disposal of Wastewater Sludge Volume 3: Requirements for the on-site and off-site disposal of sludge (2009).

7 ANNEXURE – MAPS AND OTHER SUPPORTING DOCUMENTATION

eko ENVIRONMENTAL is a Bloemfontein based company with extended expertise in specific environmental fields but also in the coordination of larger environmental management projects that involve outside contracted expertise for specialist investigations.

We provide our clients with a professional service and cost effective solutions to their environmental problems to conduct their activities, development or explore natural resources like minerals, surface and ground water, without adversely impacting on the environment.

eko ENVIRONMENTAL endeavours to provide a high quality service and prompt completion of deliverables.

services ...

- Biodiversity / Ecological assessments
- Environmental impact assessments
- Environmental management plans
- Water use license applications
- Environmental monitoring
- Waste license applications
- Environmental auditing
 - Mining Authorizations
 - Heritage assessments

APPENDIX: F



Environmental Management Programme (EMPr)

BLOEMFONTEIN OFFICE

info@ekogroup.co.za

t +27(0)51 444 4700

f +27(0)86 653 5718

Suite 227 Private Bag X01

BRANDHOF 9324

OFFICES: Vryheid Kimberley Port Elizabeth



EKO GROUP (PTY) LTD trading as Eko Environmental
Reg no. 2017/311178/07
VAT No. 4020225811

Final ENVIRONMENTAL MANAGEMENT PROGRAMME:

PROPOSED ESTABLISHMENT OF THE STERKSPRUIT
REGIONAL WASTE WATER TREATMENT WORKS
(WWTW) AND ASSOCIATED BULK INFRASTRUCTURE IN
SENQU LOCAL MUNICIPALITY, EASTERN CAPE
PROVINCE.

February 2021

Joe Gqabi District Municipality represented by Dibabani Consulting CC

Contact Person	P.F.R. Swanepoel
Address	3 Woodland Hills Boulevard Bloemfontein 9301
Tel	051 451 1814

BLOEMFONTEIN OFFICE

info@ekogroup.co.za

t +27(0)51 444 4700

f +27(0)86 653 5718

Suite 227 Private Bag X01

BRANDHOF 9324

OFFICES: Vryheid Kimberley Port Elizabeth



EKO GROUP (PTY) LTD trading as Eko Environmental

Reg no. 2017/311178/07

VAT No. 4020225811

Prepared by:

PROJECT TEAM

Environmental Assessment
Practitioner(s): Richard Williamson

Postal address: Suite 227
Private Bag X01
Brandhof
9324

Contact person(s): Richard Williamson

Tel: 051 444 4700

Fax: 086 653 5718

E-mail: richard@ekogroup.co.za

1. Objectives of the Environmental Management Plan (EMPr)

The Environmental Management Plan is intended to provide environmental specifications for the development of the Sterkspruit Regional Waste Water Treatment Works (WWTW) and associated bulk infrastructure and to put measures in place to mitigate and manage potential environmental impacts arising from the phases of the construction of the mentioned WWTW in Senqu Local Municipality, Eastern Cape Province.

The obligations of an EMPr are to:

- Ensure compliance with regulatory authority stipulations and guidelines which may be local, provincial, national and/or international;
- Ensure that there is sufficient allocation of resources on the project budget so that the scale of EMPr-related activities is consistent with the significance of project impacts;
- Verify environmental performance through information on impacts as they occur;
- Respond to unforeseen events;
- Provide feedback for continual improvement in environmental performance;
- Identify a range of mitigation measures which could reduce and mitigate the potential impacts to minimal or insignificant levels;
- Detail specific actions deemed necessary to assist in mitigating the environmental impact of the project;
- Identify measures that could optimize beneficial impacts;
- Create management structures that addresses the concerns and complaints of I&APs with regards to the development;
- Establish a method of monitoring and auditing environmental management practices during all phases of the activity;
- Ensure that safety recommendations are complied with;
- Specify time periods within which the measures contemplated in the final environmental management programme must be implemented, where appropriate;

2. Responsibility during planning and construction phase

- Identification of all possible environmental impacts that might be associated with the proposed construction of the WWTW.
- Development of the design plans in order to establish the proposed WWTW on the most suitable location on site (with the least potential environmental impacts). The WWTW should be constructed as per design plans.
- Protect the environment on the construction site.
- Minimise any potential impacts expected to be associated with the Construction Phase as far as possible (e.g. prevention of soil erosion as well as any potential groundwater impacts).
- Ensure controlled access to the site to prevent degradation.
- **Limit any potential impacts towards I&AP's during the construction of the school as far as possible.**
- Be held responsible for the implementation of the EMP.
- Be held responsible to have the EMP available on site at all times.
- Be held responsible for compliance with all relevant aspects of the EMP.
- Ensure that all problems identified during environmental audits or inspections during construction, are addressed and rectified as soon as reasonably possible.

3. Responsibility during operational phase

- Providing a budget for maintenance of infrastructure.
- Maintaining all approved infrastructure in good working order to effectively fulfil its intended purpose to prevent negative environmental impacts.
- To immediately remedy any factors that contribute to negative environmental impacts.

4. Responsibility of the Applicant

- The applicant is responsible for the implementation of the conditions in the EMP
- A responsible and suitably qualified person (Environmental Control Officer) must be appointed during the construction and operational phases to ensure that the contractor complies with the requirements in the EMP. To immediately remedy any factors that contribute to negative environmental impacts.

- During the operation phase the applicant must ensure that the relevant environmental biomonitoring is undertaken and that sufficient record is kept of this.

5. Responsibility of the Environmental Control Officer (ECO)

- Ensure that the EMP is implemented by the Contractor during the constructions phase and monitor all activities.
- Ensure that all employees, including the contractor on site are familiar with all the conditions and requirements in the EMP.
- Ensure that access routes and work areas are demarcated where activities will take place and also **“no-go” areas**.
- Communicate any information that relates to the management of environmental aspects or any change of the EMP conditions to the contractor and the applicant.
- Address any complaints from the public or official from a regulating authority appropriately and inform the applicant.
- Keep record of any complaints received: date, name, complaint and response.
- Keep a record of any non-compliance to the EMP: date, description and corrective actions.
- Report any non-compliance or incident that may have a significant impact on the environment or Kromspruit River, to Department of Environmental Affairs and the Department of Water Affairs.

6. Responsibility of the Contractor

- The contractor must be contractually bound to comply with all the conditions of the EMP
- The contractor must consult with the environmental coordinator with any matter on environmental issues
- Report any incident that may have an impact on the environment or a non-compliance of any EMP conditions to the environmental coordinator.

7. Layout plan

- A copy of the layout plan must be available at the site for scrutiny during construction when required.

8. Demarcating the development area

- The area under construction must be clearly demarcated by means of barricading.
- Identify and demarcate the extent of the construction site as indicated by the layout plan.
- Do not paint or mark any natural feature. Marking for surveying and other purposes must be done using pegs, beacons or rope and droppers.

9. Environmental Aspects to be considered during the construction phase of the project:

- The South African Heritage Resources Agency must be notified if any elements of cultural or historical importance are found.
- During the construction phase and prior to the lining of the sludge lagoons the Department of Water and Sanitation must be informed and should be present on site.
- Do not establish any activities or operations that, in the opinion of the ECO are likely to adversely affect the aesthetic quality of the environment.
- Ample chemical toilets must be placed on the site for use by the workforce. These toilets must be maintained and cleaned regularly and kept in a sanitary order.
- Potable drinking water must be available at the site office and other convenient locations on the site.
- All activities must be limited to the identified work areas and access roads.
- No hunting, capturing or harming of any faunal species on the site must be allowed.
- No open fires are allowed on site.
- The existing access roads shall be used.
- Unless otherwise specified normal work hours will apply (i.e. from 07h00 to 17h00, Mondays to Fridays).

- No emissions of gasses to the atmosphere are currently occurring or will occur as a result of the operation of the proposed WWTW.
- Chemical toilet facilities must be made available to employees during construction.
- Topsoil must be kept and stockpiled separate in an area not prone to erosion.
- Topsoil may not be utilized for construction activities and should be re-used during rehabilitation activities when construction has ceased to level the site and any disturbed areas where necessary.

- Handling of waste:
 - Non-biodegradable refuse such as glass bottles, plastic bags, metal scrap, etc., shall be disposed and stored in suitable containers at a collecting point and collected on a regular basis and disposed off at the Sterkspruit landfill site. Specific precautions shall be taken to prevent refuse from being dumped on or in the vicinity of the site.
 - Suitable covered receptacles shall be available at all times and conveniently placed for the disposal of waste for general and hazardous waste separately.
 - Spills of any product like paint, oil, diesel, petrol, cleaning agents etc. should be cleaned up immediately by removing the spillage together with the polluted soil and by disposing it at a recognised facility.
 - All used oils, grease or hydraulic fluids, paints, thinners etc. that cannot be re-used shall be placed in a hazardous waste container for disposal at a suitable waste disposal facility.
 - Best practices in terms of the management of any waste together with the recommended mitigation measures should be implemented as minimum.

- Handling of possible hazardous substances:
 - Ensure compliance with all national, regional and local legislation with regard to the disposal of hydrocarbons, chemicals, solvents and any other harmful and hazardous substances and materials.
 - Collect any hazardous waste in clearly marked receptacles located on a drip tray on site pending disposal. All receptacles should be suitably covered.
 - All spills should be cleaned up immediately by removing the spillage together with the polluted soil and be disposed of as hazardous waste.
 - Retain waste oils and batteries for recycling by the supplier wherever possible.

- Regularly dispose of all hazardous not earmarked for reuse, recycling or resale (such as oil contaminated with chlorinated hydrocarbons, electrical cleaning solvent, certain chemicals and fluorescent tubes) at a registered hazardous waste disposal site.
 - Contain chemical spills, and arrange for cleanup by the supplier, or by professional pollution control personnel.
 - Report major spills to the provincial Department of Water Affairs, as well as to the relevant Local Authority.
 - Carefully control all on-site operations that involve the use of cement and concrete.
 - Limit cement and concrete mixing to single sites as far as possible.
 - Use plastic trays or liners when mixing cement and concrete: Don not mix cement and concrete directly on the ground.
 - Dispose of all visible remains of excess cement and concrete after the completion of tasks. Dispose of cement and concrete waste in the approved manner (solid waste concrete may be treated as inert construction rubble).
 - Spill kits must be available on site and in all vehicles that transport hydrocarbons. Spill kits must be made up of material/product that is in line with environmental best practise (SUNSORB is a recommended product that is environmentally friendly).

- Bulk infrastructure pipelines:
 - The sewage pipes must be tested for defects and leaks before the trenches are closed.
 - Technically appropriate and SABS approved sewer material must be used.
 - Trenches should be barricaded and all safety measures implemented to ensure no accidents on site.

 - Topsoil must be kept and stockpiled separate in an area not prone to erosion.
 - Topsoil may not be utilized for construction activities and should be re-used during rehabilitation activities when construction has ceased to level the site and any disturbed areas where necessary.
 - All activities must be limited to the identified work areas and access roads.
 - No hunting, capturing or harming of any faunal species on the site must be allowed.
 - No open fires are allowed on site.
 - The existing access roads shall be used.

- Unless otherwise specified normal work hours will apply (i.e. from 07h00 to 17h00, Mondays to Fridays).
- Ample chemical toilets must be placed on the site for use by the workforce. These toilets must be maintained and cleaned regularly and kept in a sanitary order.
- The South African Heritage Resources Agency must be notified if any elements of cultural or historical importance are found.
- Topsoil and subsoil should not be mixed during construction and should be kept separate from another. After construction the topsoil and subsoil should be replaced in trenches and excavated holes in its original sequence.
- Storm water management measures (e.g. diversion berms, swales, channels and attenuation ponds adjacent the annual stream) will be implemented in areas where extensive erosion during the construction phase becomes problematic.
- Areas prone to damming and problematic storm water flow areas should be addressed by the implementation of appropriate storm water control measures.
- Topsoil will be stockpiled separately with the natural seed bank intact and protected against weed infestation and erosion.
- Topsoil will be replaced on top of the soil surface at disturbed areas to be rehabilitated as soon as possible.
- After cessation of the activities, the disturbed areas will be rehabilitated to acceptable standards.
- Areas that have become compacted due to the construction activities will be ripped.
- The road reserve and areas disturbed by the construction activities will be inspected regularly for the presence of invader weed species.
- Areas with extensive growth of alienated species will be cleared thereof.
- Alien species will be removed by hand prior to seeding, or by the aid of prescribed chemicals.
- Topsoil stockpile areas will be monitored for excessive growth of alienated species and well-managed not to promote erosion with the removal of any vegetation.
- The necessary wayleave application and supporting documents must be submitted to the Department of Roads and Public Works prior to commencing construction: Private Bag 1001, Aliwal North, 9750, johann.botha@dpw.ecape.gov.za, 051 633 2990.

- The Office of the District Road Engineer must be informed 14 days prior to construction and a Notice of Completion must also be submitted once construction is completed.

10. Environmental Aspects to be considered during the operational phase of the project:

- Drainage and Stormwater Control:
 - Flooding of the WWTW as well as leakage from the oxidation ponds can threaten groundwater and surface water resources. These impacts should be avoided by adopting proper engineering codes and adequate preventive measures such as a Stormwater Management Plan
 - The Contractor must compile a stormwater drainage plan for approval by the Engineer, which shall include proposals for protection against stormwater damage, and containment of flows and rehabilitation measures should any damage arise.
 - The design of oxidation ponds at the WWTW should incorporate free-board volumes which should compensate for most storm events.
 - Ensure that adequately lined drainage is in place around the outside of the ponds to ensure that any overflow is diverted back to the head of the WWTW.
 - Stormwater diversion berms should be incorporated into the site design.
- Facultative ponds, sludge lagoons and other infrastructure:
 - The design of ponds at the WWTW should incorporate free-board volumes which should compensate for most storm events.
 - Ensure that adequately lined drainage is in place around the outside of the ponds to ensure that any overflow is diverted back to the head of the WWTW.
 - Stormwater diversion berms should be incorporated into the site design.
 - Regular site inspection and critical observation of the ponds is recommended to ensure that possible leaks are identified and that environmental conditions have not impacted on the operation of the WWTW.
 - On-site operating staff **MUST** be trained and certified by the relevant authorities.
- Erosion Control:

- Increased flows in the Kromspruit due to discharge from the works can cause erosion / scour of the bed and banks below the discharge point, resulting in an increase in the supply of sediment to the downstream reaches of the river.
- In order to limit this erosion, it is recommended that erosion protection measures such as gabions and velocity dissipaters be established at the outflow point.
- Chlorine Handling:
 - As part of the wastewater treatment process, treated effluent will undergo disinfection prior to release to the environment. This will take place in chlorine contact chambers, requiring the storage of chlorine gas on the site.
 - Construction of the chlorine handling facilities must comply with the latest legal, environmental and health bylaws. The detail of this work includes:
 - The chlorine gas cylinder storeroom must be airtight;
 - Appropriate observation windows must be installed in this room;
 - Appropriate signboards must be erected within and in close proximity to this room;
 - Chlorine detectors must be installed in the storeroom, inclusive of warning light and alarm;
 - Breathing apparatus must be maintained in the storeroom;
 - A safety shower and eyewash facility must be installed and maintained in close proximity to the chlorine storeroom; and
 - Any other mechanical equipment required to facilitate the safe operation of the chlorine dosing system must be supplied and installed.
 - All equipment needed for the safe operation of chlorine dosing must be carefully maintained.
 - All pipes and dosing system infrastructure shall be maintained leak free.
- Water Quality Monitoring:
 - In general, activated sludge treatment systems produce a highly treated and well-nitrified effluent that typically meets the required effluent quality standards. Disinfection with chlorine will further suppress bacterial populations in the discharged effluent. Thus, the **proposed facilities' discharge effluent quality is expected to meet the DWA Minimum Standards** and WUL conditions for wastewater discharged into surface waters. However,

to ensure that acceptable standards are kept the effluent being discharged will be tested at regular intervals.

- Treated water will be discharged by a sewer outfall into the Kromspruit. Irrigation of treated water will not be used but will be kept as an option. However, if such an option is taken in future the necessary Water Use License will be applied for with DWS before such an activity will be undertaken.
- Monitoring must include points upstream and downstream within the Kromspruit from the WWTW to ascertain the impact and quality of discharge. Sampling points should be standardised to those currently utilised for water quality monitoring. This will ensure water samples always in approximately the same area. The following map (Map 1 below) illustrates sampling points which should be utilised for monitoring.
- There are no known boreholes located within 1 km of the site and as a result it is not possible to determine water table depth or high yield aquifers although it is considered highly unlikely. As a condition of the operation of the facility an upstream and downstream borehole should be sunk as soon as construction commences in order to be used as part of the water quality monitoring programme.
- The current water quality results are included below to serve as baseline for future water quality testing. These results also correspond to the sampling points as illustrated in Map 1 below.
- The utilisation of effluent from the WWTW must comply with the DWA Guidelines for Permissible utilisation and disposal of treated sewage effluent (1978) that allows the following uses for an oxidation pond system:
 - Irrigation of crops for human consumption which are not eaten raw.
 - Irrigation of cultivation of cut flowers.
 - Irrigation of fruit trees and vineyards.
 - Grazing for cattle (excluding milk producing animals).
 - Crops not for grazing, but utilised as dry fodder.

Table 1: Typical values for common tests (DWA 2010 Guidelines)

Test	Units	Raw Sewage	Final Effluent
COD	mg l ⁻¹	400 - 800	40 - 65

BOD	mg l ⁻¹	200 - 400	10 - 20
TKN (Total Nitrogen)	mg l ⁻¹	40 - 100	2 - 10
Ammonia	mg l ⁻¹	30 - 80	0 - 8
Nitrate	mg l ⁻¹	0	0 - 15
Suspended Solids	mg l ⁻¹	200	5 - 18
pH	-	6.5 - 8.0	6.5 - 7.5
Total Phosphorus	mg l ⁻¹	5 - 15	3 - 12
Total Phosphate	mg l ⁻¹	4 - 12	0.5 - 10

Table 2: Current water quality results at the sampling points as specified in Map 1.

Institute for Groundwater Studies IGS Laboratory Services University of the Free State 339, BLOEMFONTEIN, 9300 +27-(0)51 - 401 2317 +27-(0)51 - 401 3005 E-mail: igsiab@ufs.ac.za						
Tests Report						Page 1 of 1
Client:	Eko Environmental					
Contact:	Gys Hoon					
Reference:	Case no. 2014-989					
Sample Information						
Sample type:	4 x Sewage waters					
Date analysed:	16-Sep-14					
Date received:	16-Sep-14					
Delivered by:	Jaco 11:23					
Date sampled:	16-Sep-14					
Reporting date:	17-Sep-14					
Final report:	03-Oct-14					
Determindand	Sample number	Section 39 of the National Water Act of 1998	81	82	83	84
	Lab nr.	General Limit	889-1	889-2	889-3	889-4
	Units	Value	Value	Value	Value	Value
pH		5.5 - 9.5	8.33	8.17	8.42	7.53
Electrical conductivity	mS/m	70 - 150 mS/m above intake	34.8	47.8	37.3	44.1
Ammonia (NH3) as N	mg/L	6	0.065	0.059	0.079	16.77
Chemical Oxygen Demand (COD)	mg/L	75	14	7	16	812
Nitrate (NO3) / Nitrite (NO2) as N	mg/L	15	<0.5	<0.5	<0.5	<0.5
Orthophosphate (PO4)	mg/L	30.66	<1	<1	<1	3.46
Orthophosphate (PO4) as P	mg/L	10	<0.33	<0.33	<0.33	1.13
Suspendid Solids(SS)	mg/L	25	5.25	23.9	5.40	208
Faecal coliforms	cfu/100ml	1000	236	43	24	
E.coli	cfu/100ml		111	22	22	
Technical signature (laboratory manager): L. Doodal						
This report relates only to the samples supplied to the Laboratory at the Institute for Groundwater Studies						

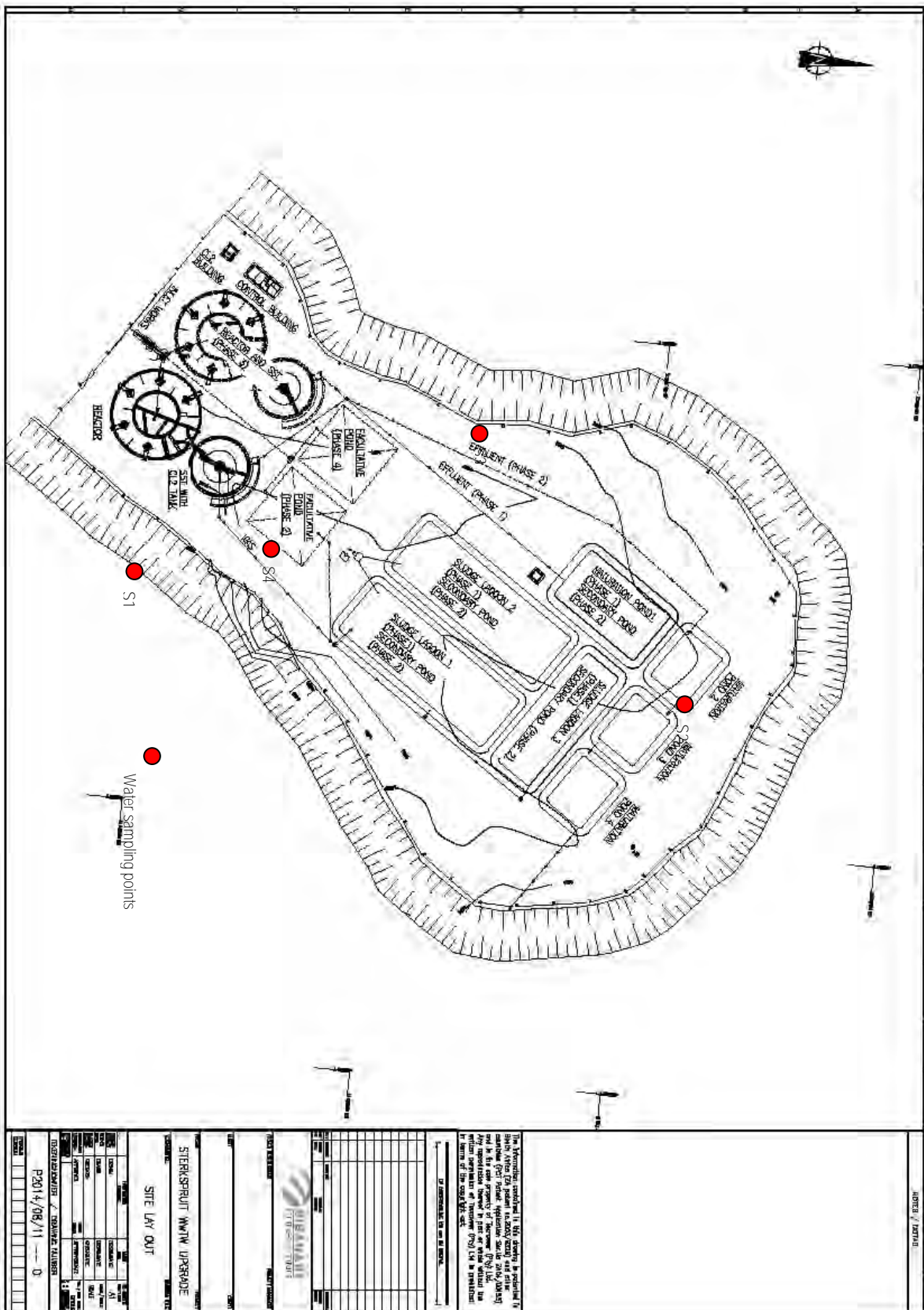

Map 1: Locations of water sampling points to be used during water quality monitoring.

- Sludge Management:
 - Following the drying of wasted sludge of the drying beds and prior to its removal off site for disposal, dried sludge will need to be stored.
 - It is recommended that sludge storage areas be designed in order to minimise the chances of sludge becoming windblown and minimise contact with stormwater to limit contamination of the environment.
 - Stabilised sewage sludge must be disposed of in accordance with the Guideline for Permissible Utilisation and Disposal of Wastewater Sludge Volume 3: Requirements for the on-site and off-site disposal of sludge (2009).
 - Stabilised sludge must be transported to the nearest registered landfill, unless a more beneficial use can be found.
 - The possible options for the disposal include the current new landfill site which is still in the planning phase and which can be investigated for the disposal of the sludge. Alternatively sludge may then be used as fertiliser on surrounding fields.
 - Since the sludge lagoons lifetime before de-sludging is required is 20 years. As a result the circumstances, technology and legislation may be markedly different at the time when sludge disposal becomes necessary. It is therefore recommended that disposal options be re-evaluated in detail at this time.

11. Health and Safety of Employees

- Any contractor and employees of the contractor responsible for the construction activities will at all times be equipped with protective gear.
- All workers on-site will undergo safety induction prior to commencement of construction activities at Sterkspruit WWTW.
- All areas posing potential safety risks and areas where protective gear is necessary will be indicated with conspicuous signs throughout the site.
- Employees must undergo training in Health and Safety of a WWTW in order to minimise the likelihood and severity of this impact.
- The municipality must implement extensive training for all employees and staff on the operation and maintenance of the WWTW.

12. Decommissioning and Rehabilitation

At present, it is not anticipated that the project will undergo decommissioning and/or closure. However, should the facility at some time become abandoned or demolished, the following minimum management measures will be implemented:

- The infrastructure will be removed during the Decommissioning Phase. Any scrap metal will be sold to a scrap metal business and any metal and scrap unable to be utilised will be removed and disposed of at a registered landfill site.
- Any concrete surfaces will be removed and compacted areas will be ripped and re-vegetated, depending on the end land use to be decided upon at the time.
- The minimum of vegetation present should be removed. Natural vegetation that is anticipated to have established during the operational phase must not be disturbed.
- Sludge will be dried and disposed of at a registered landfill site.
- Liner must be left to dry for a minimum of 30 dry weather days.

In addition to the above, the applicant should:

- Ensure that suitable arrangements are made to protect the environment against long term negative impacts.
- Clean up contaminants of the environment.
- Prevent erosion through regular monitoring and rehabilitation of degraded areas.
- Prevent spreading of exotic species from the site.
- Minimize negative visual impacts.

It is important to note that the decommissioning of a WWTW is currently a listed activity in terms of Environmental Impact Regulations of 1014, as amended. If the facility is therefore decommissioned in future the applicant would have to apply for Environmental Authorisation. This must be verified at the time of decommissioning.

13. Inspections and monitoring

The main objective of the proposed monitoring is to indicate any potential environmental impact prior to occurring and thus also provide the applicant with the opportunity to implement the proper management measures if found necessary prior to impacting on the environment.

- It is recommended that regular monitoring of all the environmental management measures and components should be undertaken during the construction phase to verify compliance to the EMPr.

- Ongoing and regular reporting of the progress of implementation of this EMPr will be done.
- Visual inspections on physical pollution shall be carried out on a regular basis.
- To ensure that acceptable standards are kept the effluent being discharged will be tested at regular intervals.
- Monitoring must include points upstream and downstream within the Kromspruit from the WWTW to ascertain the impact and quality of discharge.

14. Compliance reporting / submission of information

- An environmental officer will be appointed in terms of the specific site. The officer will be responsible to monitor all the environmental management measures and ensure compliance with the EMPr during the Construction and Operational Phase.
- A copy of the EMPr must be kept on site at all times and operation must comply with this document at all times. The EMPr is considered a legally binding document.
- Health and Safety, as well as Occupational Hygiene audits will be carried out as required by legislation during the Construction and Operational Phases.
- It is recommended that a compliance assessment should be undertaken by an independent Environmental Control Officer once during the Construction and Operational Phase to verify compliance with the EMPr. It is also recommended that an independent Environmental Control Officer should conduct a Compliance Assessment during the decommissioning phase (if applicable).
- Reports confirming compliance with various points identified in the EMPr will be kept and made available when requested.
- During the construction phase and prior to the lining of the sludge lagoons the Department of Water and Sanitation must be informed and should be present on site.
- Any emergency or unforeseen impact will be reported within 12 hours after identification to the Eastern Cape Department of Economic Development, Environmental Affairs and Tourism as well as the Department of Water and Sanitation telephonically and confirmed in writing.

APPENDIX: G



Impact Assessment

BLOEMFONTEIN OFFICE

info@ekogroup.co.za

t +27(0)51 444 4700

f +27(0)86 653 5718

Suite 227 Private Bag X01

BRANDHOF 9324

OFFICES: Vryheid Kimberley Port Elizabeth



EKO GROUP (PTY) LTD trading as Eko Environmental

Reg no. 2017/311178/07

VAT No. 4020225811

IMPACT ASSESSMENT:

THE PROPOSED ESTABLISHMENT OF THE
STERKSPRUIT REGIONAL WASTE WATER TREATMENT
WORKS (WWTW) AND ASSOCIATED BULK
INFRASTRUCTURE IN SENQU LOCAL MUNICIPALITY,
EASTERN CAPE PROVINCE.

February 2021

Joe Gqabi District Municipality represented by Dibabani Consulting CC

Contact Person Mr. P.F.R. Swanepoel
Address 3 Woodland Hills
Boulevard
Bloemfontein
9301
Tel: 051 451 1814

Prepared by:

BLOEMFONTEIN OFFICE
info@ekogroup.co.za
t +27(0)51 444 4700
f +27(0)86 653 5718

Suite 227 Private Bag X01
BRANDHOF 9324

OFFICES: Vryheid Kimberley Port Elizabeth



EKO GROUP (PTY) LTD trading as Eko Environmental
Reg no. 2017/311178/07
VAT No. 4020225811

PROJECT TEAM

Environmental Assessment Practitioner(s): Richard Williamson
Louis van Niekerk

Postal address: Suite 227
Private Bag X01
Brandhof
9324

Contact person(s): Richard Williamson

Tel: 051 444 4700

Fax: 086 653 5718

E-mail: richard@ekogroup.co.za

1. Assessment methodology

The environmental significance assessment methodology is based on the following determination:

Environmental Significance = Overall Consequence x Overall Likelihood.

1.1 Determination of Consequence

Consequence analysis is a mixture of quantitative and qualitative information and the outcome can be positive or negative. Several factors can be used to determine consequence. For the purpose of determining the environmental significance in terms of consequence, the following factors were chosen: Severity/Intensity, Duration and Extent/Spatial Scale. Each factor is assigned a rating of 1 to 5, as described in the tables below.

Determination of Severity

Severity relates to the nature of the event, aspect or impact to the environment and describes how severe the aspects impact on the biophysical and socio-economic environment (Table 1).

Table 1: Rating of severity

Type of criteria	Rating				
	1	2	3	4	5
Quantitative	0-20%	21-40%	41-60%	61-80%	81-100%
Qualitative	Insignificant / Non-harmful	Small / Potentially harmful	Significant / Harmful	Great / Very harmful	Disastrous / Extremely harmful
Social/ Community response	Acceptable / I&AP satisfied	Slightly tolerable / Possible objections	Intolerable/ Sporadic complaints	Unacceptable / Widespread complaints	Totally unacceptable / Possible legal action
Irreversibility	Very low cost to mitigate/ High potential to mitigate impacts to level of insignificance / Easily reversible	Low cost to mitigate	Substantial cost to mitigate / Potential to mitigate impacts / Potential to reverse impact	High cost to mitigate	Prohibitive cost to mitigate / Little or no mechanism to mitigate impact / Irreversible
Biophysical (Air quality, water quantity and quality, waste production, fauna and flora)	Insignificant change / deterioration or disturbance	Moderate change / deterioration or disturbance	Significant change / deterioration or disturbance	Very significant change / deterioration or disturbance	Disastrous change / deterioration or disturbance

Determination of Duration

Duration refers to the amount of time that the environment will be affected by the event, risk or impact, if no intervention e.g. remedial action takes place (Table 2).

Table 2: Rating of Duration

Rating	Description
1: Low	Almost never / almost impossible
2: Low-Medium	Very seldom / highly unlikely
3: Medium	Infrequent / unlikely / seldom
4: Medium-High	Often / regularly / likely / possible
5: High	Daily / highly likely / definitely

Determination of Extent/Spatial Scale

Extent refer to the spatial influence of an impact be local (extending only as far as the activity, or will be limited to the site and its immediate surroundings), regional (will have an impact on the region), national (will have an impact on a national scale) or international (impact across international borders) (Table 3).

Table 3: Rating of Extent / Spatial Scale

Rating	Description
1: Low	Immediate, fully contained area
2: Low-Medium	Surrounding area
3: Medium	Within Business Unit area of responsibility
4: Medium-High	Within Mining Boundary area
5: High	Regional, National, International

Determination of Overall Consequence

Overall consequence is determined by adding the factors determined above and summarised below, and then dividing the sum by 4 (Table 4).

Table 4: Example of calculating Overall Consequence

Consequence	Rating
Severity	Example 4
Duration	Example 2
Extent	Example 4

SUBTOTAL	Example 10
TOTAL CONSEQUENCE:(Subtotal divided by 4)	Example 3.3

Likelihood

The determination of likelihood is a combination of Frequency and Probability. Each factor is assigned a rating of 1 to 5, as described and in Tables 5 and 6.

Determination of Frequency

Frequency refers to how often the specific activity, related to the event, aspect or impact, is undertaken (Table 5).

Table 5: Rating of frequency

Rating	Description
1: Low	Once a year or once / more during operation / LOM
2: Low-Medium	Once / more in 6 Months
3: Medium	Once / more a Month
4: Medium-High	Once / more a Week
5: High	Daily

Determination of Probability

Probability refers to how often the activity/event or aspect has an impact on the environment (Table 6).

Table 6: Rating of probability

Rating	Description
1: Low	Almost never / almost impossible
2: Low-Medium	Very seldom / highly unlikely
3: Medium	Infrequent / unlikely / seldom
4: Medium-High	Often / regularly / likely / possible
5: High	Daily / highly likely / definitely

Overall Likelihood

Overall likelihood is calculated by adding the factors determined above and summarised below, and then dividing the sum by 2 (Table 7).

Table 7: Example of calculating the overall likelihood

Consequence	Rating
Frequency	Example 4
Probability	Example 2
SUBTOTAL	Example 6
TOTAL LIKELIHOOD (Subtotal divided by 2)	Example 3

Determination of Overall Environmental Significance

The multiplication of overall consequence with overall likelihood will provide the environmental significance, which is a number that will then fall into a range of LOW, LOW-MEDIUM, MEDIUM, MEDIUM, MEDIUM-HIGH or HIGH, as shown in the table below (Table 8).

Table 8: Determination of overall environmental significance

Significance or Risk	Low	Low-Moderate	Moderate	Moderate-High	High
Overall Consequence X Overall Likelihood	1 - 4.9	5 - 9.9	10 - 14.9	15 – 19.9	20 - 25

Qualitative description or magnitude of Environmental Significance

This description is qualitative and is an indication of the nature or magnitude of the Environmental Significance. It also guides the prioritisations and decision making process associated with this event, aspect or impact (Table 9).

Table 9: Description of the environmental significance and the related action required.

Significance	Low	Low-Moderate	Moderate	Moderate-High	High
Impact Magnitude	Impact is of very low order and therefore likely to have very little real effect. Acceptable.	Impact is of low order and therefore likely to have little real effect. Acceptable.	Impact is real, and potentially substantial in relation to other impacts. Can pose a risk to the company	Impact is real and substantial in relation to other impacts. Pose a risk to the company. Unacceptable	Impact is of the highest order possible. Unacceptable. Fatal flaw.
Action Required	Maintain current management measures. Where possible improve.	Maintain current management measures. Implement monitoring and evaluate to determine	Implement monitoring. Investigate mitigation measures and improve management measures to	Improve management measures to reduce risk.	Implement significant mitigation measures or implement alternatives.

Significance	Low	Low-Moderate	Moderate	Moderate-High	High
		potential increase in risk. Where possible improve	reduce risk, where possible.		

1.2 Environmental Impact Assessment

Alternative 1 - Proposed project									
Activity and potential impacts	Mitigation	Significance with or without mitigation	Severity	Duration	Extent	Consequence	Frequency	Probability	Likelihood
<p>Health and safety: Potential dangerous working conditions, e.g. height of structure to be constructed, construction vehicles, etc.</p> <ul style="list-style-type: none"> • Potential safety risks to employees and the general public 	<ul style="list-style-type: none"> • Equip all employees and / or contractors working on the site with the necessary protective gear. • Implementation of safety induction. • Training on the relevant machinery. • Adequate fencing must be erected around the site. • Warning signs must be attached to fencing and at the entrance of the construction site. • The pipeline construction areas must be clearly marked off. • Excavations for the pipelines must be closed as quickly as possible to decrease the likelihood of accidents. • Measures must be implemented to ensure that pipeline excavations are safe to the general public. This is especially relevant to night times when excavations are not easily visible. • Construction of the chlorine handling 	<p>Without : 11.5 With: 5.6</p>	<p>4 2</p>	<p>2 2</p>	<p>1 1</p>	<p>2.3 1.6</p>	<p>5 5</p>	<p>5 2</p>	<p>5 3.5</p>

Alternative 1 - Proposed project									
Activity and potential impacts	Mitigation	Significance with or without mitigation	Severity	Duration	Extent	Consequence	Frequency	Probability	Likelihood
	facilities must comply with the latest legal, environmental and health bylaws.								
Clearance of site, protection of vegetation and animals <ul style="list-style-type: none"> • Loss of natural occurring vegetation • Establishment of alien species in the surrounding area • Erosion • Soil loss 	<ul style="list-style-type: none"> • In cases where topsoil is to be removed from the construction area, the topsoil should be handled as discussed in Stockpile Management (EMPr). • Clearance of vegetation will be limited to the area under construction, within the site boundaries and pipeline route. • Establishment of alien vegetation should be monitored on a regular basis. • Areas with extensive growth of alienated species should be removed by hand. • As states within the BAR and ecological assessment the condition of the site is highly degraded and 	Without: 2.4 With: 1.6	1 1	3 3	1 1	1.6 1.6	1 1	2 1	1.5 1

Alternative 1 - Proposed project									
Activity and potential impacts	Mitigation	Significance with or without mitigation	Severity	Duration	Extent	Consequence	Frequency	Probability	Likelihood
	<p>transformed and the impact on the vegetation would therefore be minimal.</p> <ul style="list-style-type: none"> No harming, hunting, capturing or trapping of animals on the site may occur. No open fires will be allowed. 								
<p>Waste Management</p> <ul style="list-style-type: none"> General Waste Camp Site Waste Hazardous waste Negative visual impact Hazardous environment for animals Soil and water (surface and underground resources) contamination Waste Dumping on site 	<ul style="list-style-type: none"> Identify and separate waste streams. Suitable receptacles should be placed at convenient areas (where construction is currently active) for the collection of general waste. These receptacles should be emptied on a regular basis (or when necessary) and disposed of at an authorized landfill site in Sterkspruit/Lady Grey. No construction and or any other waste may be dumped in the veld. All building rubble will be removed by the contractor on a regular basis and disposed of at an authorised landfill site in Sterkspruit or used as filling material during construction. 	<p>Without: 13.3 With: 5.3</p>	<p>3 2</p>	<p>4 4</p>	<p>3 2</p>	<p>3.3 2.7</p>	<p>4 3</p>	<p>4 3</p>	<p>4 2</p>

Alternative 1 - Proposed project

Activity and potential impacts	Mitigation	Significance with or without mitigation	Severity	Duration	Extent	Consequence	Frequency	Probability	Likelihood
	<ul style="list-style-type: none"> • All used oils, grease or hydraulic fluids, paints, thinners etc. that cannot be re-used shall be placed in a hazardous waste container for disposal at a suitable waste disposal facility. Scrap metal should be collected and sold to a local scrap metal recycler. • Provide suitable containers for collection of waste (general, scrap metal, building rubble, etc.) • Any hazardous waste should be managed according to best practice and dispose of at an authorized facility. • General Waste will be disposed of at an authorized waste site in Sterkspruit/Lady Grey. • Temporary ablution facilities must be made available on site during the construction phase. • These facilities must be implemented in such a way that no water or other resources are polluted by these 								

Alternative 1 - Proposed project									
Activity and potential impacts	Mitigation	Significance with or without mitigation	Severity	Duration	Extent	Consequence	Frequency	Probability	Likelihood
	<p>facilities.</p> <ul style="list-style-type: none"> A contractor should clean the facilities on a regular basis. Proof of the cleaning schedule should be made available on request. 								
<p>Storm Water Management</p> <ul style="list-style-type: none"> Potential erosion of the exposed soil. Possible spillage of untreated sewage to the surrounding environment. Discharged treated water may not meet DWS minimum standards. Pollution due to spillage or seepage of sewage and sludge from the lagoons into groundwater and the surrounding Komspruit. Increased flows in the Kromspruit due to discharge from the works can cause erosion of the bed and banks and an increase in sediment to the downstream reaches. 	<ul style="list-style-type: none"> Appropriate storm water measures. Repair damage to culverts and other storm water management systems. Rehabilitation of the riparian habitat. Removal of alien vegetation. During construction, storm water measures such as channels, diversion berms, etc. will be constructed around the construction site in order to limit and/or prevent erosion and separate clean and dirty runoff. Maintenance of the WWTW should be continued to ensure an optimal working area. The design of the WWTW reticulation system should be such to ensure competent operation and separated from the consumable water system. 	<p>Without: 10.8 With: 2.3</p>	<p>4 2</p>	<p>4 2</p>	<p>3 3</p>	<p>3.6 2.3</p>	<p>4 1</p>	<p>2 1</p>	<p>3 1</p>

Alternative 1 - Proposed project

Activity and potential impacts	Mitigation	Significance with or without mitigation	Severity	Duration	Extent	Consequence	Frequency	Probability	Likelihood
	<ul style="list-style-type: none"> • Conduct regular inspections of infrastructure at intervals so as to identify any potential failure of infrastructure and repair immediately. • Develop a contingency plan for periods of load shedding that will prevent the release of raw sewage into the Kromspruit. • Adopt proper engineering codes and implement a storm water management plan. • The design of oxidation ponds should incorporate free- board volumes which should compensate for most storm events. • Ensure that adequately lined drainage is in place around the outside of the ponds to ensure that any overflow is diverted back to the head of the WWTW. • Stormwater diversion berms should be incorporated into the site design. • Regular site inspection and critical observation of the ponds is 								

Alternative 1 - Proposed project									
Activity and potential impacts	Mitigation	Significance with or without mitigation	Severity	Duration	Extent	Consequence	Frequency	Probability	Likelihood
	<p>recommended to ensure that possible leaks are identified and that environmental conditions have not impacted on the operation of the WWTW.</p> <ul style="list-style-type: none"> • On-site operating staff MUST be trained and certified by the relevant authorities. • The sewage pipes must be tested for defects and leaks before the trenches are closed. • Technically appropriate and SABS approved sewer material must be used. • In order to limit erosion measures such as gabions and velocity dissipaters must be established at the outflow point. • Activated sludge treatment systems produce a highly treated and well-nitrified effluent that typically meets the required effluent quality standards. However, to ensure that acceptable standards are kept the 								

Alternative 1 - Proposed project									
Activity and potential impacts	Mitigation	Significance with or without mitigation	Severity	Duration	Extent	Consequence	Frequency	Probability	Likelihood
	effluent being discharged will be tested at regular intervals.								
Handling of hazardous substances • Contamination of soil and water resources (surface and underground resources)	<ul style="list-style-type: none"> Hydraulic substances (Petrol, Diesel, Oil, Grease) should each be kept separate, within an area enclosed with a bunded wall. Drip trays should be used during transfer of any hazardous substances from transportation vehicles. Any spill of potential hazardous substances into any water resource should be reported to DWS. Any spillage should be cleaned immediately to prevent contamination of storm water and groundwater resources. No dumping of any waste material (including construction rubble) into any water resource. 	Without: 11.0 With: 5.0	4 2	3 2	4 2	3.7 2	3 3	3 2	3 2.5
Protection of cultural environment • The adjacent cultural environment could be harmed due to the rehabilitation process of the said road	<ul style="list-style-type: none"> If any signs of culturally or historically significant elements (including archaeological or paleontological elements) are discovered during the 	Without: 2.5 With: 2.5	1 1	1 1	1 1	1 1	4 4	1 1	2.5 2.5

Alternative 1 - Proposed project									
Activity and potential impacts	Mitigation	Significance with or without mitigation	Severity	Duration	Extent	Consequence	Frequency	Probability	Likelihood
	<p>construction process of the said WWTW and associated pipelines.</p> <ul style="list-style-type: none"> • All activities on and close to the discovery should discontinue. • An archaeologist paleontologist should be notified. • SAHRA should be notified. • The activities may continue if the contractor received written consent from SAHRA and / or the specialists (paleontologist / archaeologist). 								
<p>Noise generation</p> <ul style="list-style-type: none"> • Elevated noise levels could disturb adjacent land owners. 	<ul style="list-style-type: none"> • The construction process should be limited to normal working hours in order to limit the significance of the noise levels. • The nearest residences are located 500 meters from the site and is therefore unlikely to be affected by noise caused by construction. 	<p>Without: 18.5 With: 5.6</p>	<p>2 1</p>	<p>5 3</p>	<p>4 1</p>	<p>3.7 1.6</p>	<p>5 5</p>	<p>5 2</p>	<p>5 3.5</p>
<p>Air Quality</p> <ul style="list-style-type: none"> • The liberation of dust during construction might have a negative effect on the visual impact in the surrounding environment. 	<ul style="list-style-type: none"> • The formation of dust should be controlled if it becomes problematic by the use of, inter alia, water spraying and / or other dust-allaying agents. 	<p>Without: 10 With: 5.6</p>	<p>1 1</p>	<p>3 3</p>	<p>2 1</p>	<p>2 1.6</p>	<p>5 5</p>	<p>5 2</p>	<p>5 3.5</p>

Alternative 1 - Proposed project									
Activity and potential impacts	Mitigation	Significance with or without mitigation	Severity	Duration	Extent	Consequence	Frequency	Probability	Likelihood
<ul style="list-style-type: none"> Emissions in the form of engine emissions might negatively affect the air quality on site as well as the surrounding environment Increased odour levels at the WWTW. 	<ul style="list-style-type: none"> The speed of trucks and other construction vehicles on the access road must be limited to 35 km/hour to minimize the formation of dust. Vehicles should be in a good working condition. The current WWTW is not functional and as a consequence odour levels are high and the new WWTW is anticipated to alleviate this problem. Odour control must be adequately provided for in the design and specification of the new WWTW. 								
<p>Stockpile Management</p> <ul style="list-style-type: none"> Contamination of different stockpiled material Erosion Loss of topsoil 	<ul style="list-style-type: none"> Different materials should be stored separately in order to protect the material from being contaminated with other material to be stockpiled / stored. The surface of the site will be levelled to ensure a free-draining surface to prevent ponding of surface water as well as to limit erosion. No construction with topsoil is allowed. 	Without: 13.3 With: 4.0	3 1	4 3	3 2	3.3 2	4 3	4 1	4 2

Alternative 1 - Proposed project

Activity and potential impacts	Mitigation	Significance with or without mitigation	Severity	Duration	Extent	Consequence	Frequency	Probability	Likelihood
	<ul style="list-style-type: none"> • Topsoil should be removed from all areas where physical disturbance of the surface will occur. • Topsoil must be kept separate and shall not be used for building or maintenance of access roads. • Topsoil should be protected from material that might contaminate the topsoil (for example: hydraulic waste). • Erosion of topsoil stockpiles should be limited. • Topsoil may be used for leveling after the construction phase has been completed. • Excess topsoil will be removed by the contractor after the construction phase has been completed. 								

Alternative 2 - Oxidation ponds

Activity and potential impacts	Mitigation	Significance with or without mitigation	Severity	Duration	Extent	Consequence	Frequency	Probability	Likelihood
<p>Health and safety: Potential dangerous working conditions, e.g. height of structure to be constructed, construction vehicles, etc.</p> <ul style="list-style-type: none"> • Potential safety risks to employees and the general public 	<ul style="list-style-type: none"> • Equip all employees and / or contractors working on the site with the necessary protective gear. • Implementation of safety induction. • Training on the relevant machinery. • Adequate fencing must be erected around the site. • Warning signs must be attached to fencing and at the entrance of the construction site. • The pipeline construction areas must be clearly marked off. • Excavations for the pipelines must be closed as quickly as possible to decrease the likelihood of accidents. • Measures must be implemented to ensure that pipeline excavations are safe to the general public. This is especially relevant to night times when excavations are not easily visible. • Construction of the chlorine handling facilities must comply with the latest legal, environmental and health bylaws. 	<p>Without : 11.5 With: 5.6</p>	<p>4 2</p>	<p>2 2</p>	<p>1 1</p>	<p>2.3 1.6</p>	<p>5 5</p>	<p>5 2</p>	<p>5 3.5</p>

Alternative 2 - Oxidation ponds									
Activity and potential impacts	Mitigation	Significance with or without mitigation	Severity	Duration	Extent	Consequence	Frequency	Probability	Likelihood
Clearance of site, protection of vegetation and animals <ul style="list-style-type: none"> • Loss of natural occurring vegetation • Establishment of alien species in the surrounding area • Erosion • Soil loss 	<ul style="list-style-type: none"> • In cases where topsoil is to be removed from the construction area, the topsoil should be handled as discussed in Stockpile Management (EMPr). • Clearance of vegetation will be limited to the area under construction, within the site boundaries and pipeline route. • Establishment of alien vegetation should be monitored on a regular basis. • Areas with extensive growth of alienated species should be removed by hand. • As states within the BAR and ecological assessment the condition of the site is highly degraded and transformed and the impact on the vegetation would therefore be minimal. • No harming, hunting, capturing or trapping of animals on the site may occur. 	Without: 5.2 With: 3.9	1 1	3 3	4 4	2.6 2.6	1 1	3 2	2 1.5

Alternative 2 - Oxidation ponds									
Activity and potential impacts	Mitigation	Significance with or without mitigation	Severity	Duration	Extent	Consequence	Frequency	Probability	Likelihood
	<ul style="list-style-type: none"> No open fires will be allowed. The oxidation pond system will require a very large area to be transformed and it is therefore anticipated that the impact on the vegetation will be exceedingly higher. Due to the large area required for the oxidation ponds it is anticipated that there will be an impact on the animals in the area. 								
Waste Management <ul style="list-style-type: none"> General Waste Camp Site Waste Hazardous waste Negative visual impact Hazardous environment for animals Soil and water (surface and underground resources) contamination Waste Dumping on site 	<ul style="list-style-type: none"> Identify and separate waste streams. Suitable receptacles should be placed at convenient areas (where construction is currently active) for the collection of general waste. These receptacles should be emptied on a regular basis (or when necessary) and disposed of at an authorized landfill site in Sterkspruit/Lady Grey. No construction and or any other waste may be dumped in the veld. All building rubble will be removed by the contractor on a regular basis 	Without: 13.3 With: 5.3	3 2	4 4	3 2	3.3 2.7	4 3	4 3	4 2

Alternative 2 - Oxidation ponds									
Activity and potential impacts	Mitigation	Significance with or without mitigation	Severity	Duration	Extent	Consequence	Frequency	Probability	Likelihood
	<p>and disposed of at an authorised landfill site in Sterkspruit or used as filling material during construction.</p> <ul style="list-style-type: none"> • All used oils, grease or hydraulic fluids, paints, thinners etc. that cannot be re-used shall be placed in a hazardous waste container for disposal at a suitable waste disposal facility. Scrap metal should be collected and sold to a local scrap metal recycler. • Provide suitable containers for collection of waste (general, scrap metal, building rubble, etc.) • Any hazardous waste should be managed according to best practice and dispose of at an authorized facility. • General Waste will be disposed of at an authorized waste site in Sterkspruit/Lady Grey. • Temporary ablution facilities must be made available on site during the construction phase. 								

Alternative 2 - Oxidation ponds									
Activity and potential impacts	Mitigation	Significance with or without mitigation	Severity	Duration	Extent	Consequence	Frequency	Probability	Likelihood
	<ul style="list-style-type: none"> • These facilities must be implemented in such a way that no water or other resources are polluted by these facilities. • A contractor should clean the facilities on a regular basis. Proof of the cleaning schedule should be made available on request. 								
<p>Storm Water Management</p> <ul style="list-style-type: none"> • Potential erosion of the exposed soil. • Possible spillage of untreated sewage to the surrounding environment. • Discharged treated water may not meet DWS minimum standards. • Pollution due to spillage or seepage of sewage and sludge from the lagoons into groundwater and the surrounding Komspruit. • Increased flows in the Kromspruit due to discharge from the works can cause erosion of the bed and banks and an increase in sediment to the downstream reaches. 	<ul style="list-style-type: none"> • Appropriate storm water measures. • Repair damage to culverts and other storm water management systems. • Rehabilitation of the riparian habitat. • Removal of alien vegetation. • During construction, storm water measures such as channels, diversion berms, etc. will be constructed around the construction site in order to limit and/or prevent erosion and separate clean and dirty runoff. • Maintenance of the WWTW should be continued to ensure an optimal working area. • The design of the WWTW reticulation 	<p>Without: 10.8 With: 6.6</p>	4 4	4 4	3 2	3.6 3.3	4 2	2 2	3 2

Alternative 2 - Oxidation ponds									
Activity and potential impacts	Mitigation	Significance with or without mitigation	Severity	Duration	Extent	Consequence	Frequency	Probability	Likelihood
	<p>system should be such to ensure competent operation and separated from the consumable water system.</p> <ul style="list-style-type: none"> • Conduct regular inspections of infrastructure at intervals so as to identify any potential failure of infrastructure and repair immediately. • Develop a contingency plan for periods of load shedding that will prevent the release of raw sewage into the Kromspruit. • Adopt proper engineering codes and implement a storm water management plan. • The design of oxidation ponds should incorporate free- board volumes which should compensate for most storm events. • Ensure that adequately lined drainage is in place around the outside of the ponds to ensure that any overflow is diverted back to the head of the WWTW. • Stormwater diversion berms should 								

Alternative 2 - Oxidation ponds									
Activity and potential impacts	Mitigation	Significance with or without mitigation	Severity	Duration	Extent	Consequence	Frequency	Probability	Likelihood
	<p>be incorporated into the site design.</p> <ul style="list-style-type: none"> • Regular site inspection and critical observation of the ponds is recommended to ensure that possible leaks are identified and that environmental conditions have not impacted on the operation of the WWTW. • On-site operating staff MUST be trained and certified by the relevant authorities. • The sewage pipes must be tested for defects and leaks before the trenches are closed. • Technically appropriate and SABS approved sewer material must be used. • In order to limit erosion measures such as gabions and velocity dissipaters must be established at the outflow point. • The oxidation pond system cannot be discharged into the Kromspruit due to unacceptable water quality 								

Alternative 2 - Oxidation ponds									
Activity and potential impacts	Mitigation	Significance with or without mitigation	Severity	Duration	Extent	Consequence	Frequency	Probability	Likelihood
	standards and treated water will have to irrigated.								
Handling of hazardous substances • Contamination of soil and water resources (surface and underground resources)	<ul style="list-style-type: none"> Hydraulic substances (Petrol, Diesel, Oil, Grease) should each be kept separate, within an area enclosed with a bunded wall. Drip trays should be used during transfer of any hazardous substances from transportation vehicles. Any spill of potential hazardous substances into any water resource should be reported to DWS. Any spillage should be cleaned immediately to prevent contamination of storm water and groundwater resources. No dumping of any waste material (including construction rubble) into any water resource. 	Without: 11.0 With: 5.0	4 2	3 2	4 2	3.7 2	3 3	3 2	3 2.5
Protection of cultural environment • The adjacent cultural environment could be harmed due to the rehabilitation process of the said road	<ul style="list-style-type: none"> If any signs of culturally or historically significant elements (including archaeological or paleontological elements) are discovered during the 	Without: 2.5 With: 2.5	1 1	1 1	1 1	1 1	4 4	1 1	2.5 2.5

Alternative 2 - Oxidation ponds									
Activity and potential impacts	Mitigation	Significance with or without mitigation	Severity	Duration	Extent	Consequence	Frequency	Probability	Likelihood
	<p>construction process of the said WWTW and associated pipelines.</p> <ul style="list-style-type: none"> • All activities on and close to the discovery should discontinue. • An archaeologist paleontologist should be notified. • SAHRA should be notified. • The activities may continue if the contractor received written consent from SAHRA and / or the specialists (paleontologist / archaeologist). 								
<p>Noise generation</p> <ul style="list-style-type: none"> • Elevated noise levels could disturb adjacent land owners. 	<ul style="list-style-type: none"> • The construction process should be limited to normal working hours in order to limit the significance of the noise levels. • The nearest residences are located 500 meters from the site and is therefore unlikely to be affected by noise caused by construction. • Oxidation ponds will require a much larger footprint which will generate more noise and will impact on a larger area. 	<p>Without: 18.5 With: 10.3</p>	<p>2 1</p>	<p>5 3</p>	<p>4 3</p>	<p>3.7 2.3</p>	<p>5 5</p>	<p>5 4</p>	<p>5 4.5</p>

Alternative 2 - Oxidation ponds									
Activity and potential impacts	Mitigation	Significance with or without mitigation	Severity	Duration	Extent	Consequence	Frequency	Probability	Likelihood
<p>Air Quality</p> <ul style="list-style-type: none"> • The liberation of dust during construction might have a negative effect on the visual impact in the surrounding environment. • Emissions in the form of engine emissions might negatively affect the air quality on site as well as the surrounding environment • Increased odour levels at the WWTW. 	<ul style="list-style-type: none"> • The formation of dust should be controlled if it becomes problematic by the use of, inter alia, water spraying and / or other dust-allaying agents. • The speed of trucks and other construction vehicles on the access road must be limited to 35 km/hour to minimize the formation of dust. • Vehicles should be in a good working condition. • The current WWTW is not functional and as a consequence odour levels are high and the new WWTW is anticipated to alleviate this problem. • Odour control must be adequately provided for in the design and specification of the new WWTW. • Due to the large area required for the oxidation ponds it is anticipated that the odour impact will be considerably higher. 	<p>Without: 20 With: 10.4</p>	<p>2 2</p>	<p>4 3</p>	<p>5 3</p>	<p>4 2.6</p>	<p>5 5</p>	<p>5 3</p>	<p>5 4</p>

Alternative 2 - Oxidation ponds									
Activity and potential impacts	Mitigation	Significance with or without mitigation	Severity	Duration	Extent	Consequence	Frequency	Probability	Likelihood
Stockpile Management <ul style="list-style-type: none"> • Contamination of different stockpiled material • Erosion • Loss of topsoil 	<ul style="list-style-type: none"> • Different materials should be stored separately in order to protect the material from being contaminated with other material to be stockpiled / stored. • The surface of the site will be levelled to ensure a free-draining surface to prevent ponding of surface water as well as to limit erosion. • No construction with topsoil is allowed. • Topsoil should be removed from all areas where physical disturbance of the surface will occur. • Topsoil must be kept separate and shall not be used for building or maintenance of access roads. • Topsoil should be protected from material that might contaminate the topsoil (for example: hydraulic waste). • Erosion of topsoil stockpiles should be limited. • Topsoil may be used for leveling 	Without: 13.3 With: 4.0	3 1	4 3	3 2	3.3 2	4 3	4 1	4 2

Alternative 2 - Oxidation ponds

Activity and potential impacts	Mitigation	Significance with or without mitigation	Severity	Duration	Extent	Consequence	Frequency	Probability	Likelihood
	after the construction phase has been completed. • Excess topsoil will be removed by the contractor after the construction phase has been completed.								

In summary:

All of the above alternatives will have a similar environmental impact as the preferred alternative. The exceptions are listed below:

Activity and potential impacts	Mitigation	Significance with or without mitigation	Severity	Duration	Extent	Consequence	Frequency	Probability	Likelihood
Alternative 2 - Oxidation ponds									
Clearance of site, protection of vegetation and animals <ul style="list-style-type: none"> • Loss of natural occurring vegetation • Establishment of alien species in the surrounding area • Erosion • Soil loss 	<ul style="list-style-type: none"> • The same as the preferred except: • The oxidation pond system will require a very large area to be transformed and it is therefore anticipated that the impact on the vegetation will be exceedingly higher. • Due to the large area required for the oxidation ponds it is anticipated that there will be an impact on the animals in the area. 	Without: 5.2 With: 3.9	1 1	3 3	4 4	2.6 2.6	1 1	3 2	2 1.5
Storm Water Management <ul style="list-style-type: none"> • Potential erosion of the exposed soil. • Possible spillage of untreated sewage to the surrounding environment. • Discharged treated water may not meet DWS minimum standards. • Pollution due to spillage or seepage of sewage and sludge from the lagoons into groundwater and the surrounding Komspruit. • Increased flows in the Kromspruit due to 	<ul style="list-style-type: none"> • The same as the preferred except: • The oxidation pond system cannot be discharged into the Kromspruit due to unacceptable water quality standards and treated water will have to irrigated. 	Without: 10.8 With: 6.6	4 4	4 4	3 2	3.6 3.3	4 2	2 2	3 2

Activity and potential impacts	Mitigation	Significance with or without mitigation	Severity	Duration	Extent	Consequence	Frequency	Probability	Likelihood
discharge from the works can cause erosion of the bed and banks and an increase in sediment to the downstream reaches.									
Noise generation Elevated noise levels could disturb adjacent land owners.	<ul style="list-style-type: none"> • The same as the preferred except: • Oxidation ponds will require a much larger footprint which will generate more noise and will impact on a larger area. 	Without: 18.5 With: 10.3	2 1	5 3	4 3	3.7 2.3	5 5	5 4	5 4.5
Air Quality <ul style="list-style-type: none"> • The liberation of dust during construction might have a negative effect on the visual impact in the surrounding environment. • Emissions in the form of engine emissions might negatively affect the air quality on site as well as the surrounding environment • Increased odour levels at the WWTW. 	<ul style="list-style-type: none"> • The same as the preferred except: • Due to the large area required for the oxidation ponds it is anticipated that the odour impact will be considerably higher. 	Without: 20 With: 10.4	2 2	4 3	5 3	4 2.6	5 5	5 3	5 4

Conclusion

The proposed development was conducted in accordance with the Environmental Impact Assessment Regulations of 2014, as amended, in terms of the National Environmental Management Act (NEMA), 1998 (Act 107 of 1998). The Environmental Impact Assessment (EIA) process consisted of several phases:

- The notification stage in which directly affected landowners, ward councillors, stakeholders, communities, interested parties, key stakeholders as well as authorities were notified of the proposed development. Initial information in the form of a Background Information Document (BID) was also supplied to these parties. Additionally, site notices in three languages as well as notifications in a local newspaper (i.e. Daily Dispatch) and a regional newspaper (Aliwal Weekblad) also contributed to **notifying possible I&AP's of the proposed project**. A communication channel was initiated with these parties to obtain queries and concerns and also to provide information to these parties.
- This document incorporates all concerns and potential impacts relating to the development and identifies the specialist need within the process.
- The EIA stage wherein the specialist input is incorporated and the likely impacts arising from these are considered in respect of the proposed development. The phase includes the development of mitigation measures and the development of an Environmental Management Program (EMPr).

Summary of the proposed project:

The project entails the replacement of the Sterkspruit Regional Waste Water Treatment Works (WWTW) and associated bulk infrastructure. Dibabani Consulting has been appointed to apply for Environmental Authorisation on behalf of Je Gqabi District Municipality and thereafter to construct a WWTW as well as lift pump stations and bulk connector services. The bulk connector sewer system will service Sterkspruit, Esilindini, Mogesi and Tapoleng townships.

The proposed WWTW site falls within the D12A quaternary drainage area within the Upper Orange Water Management Area. The Kromspruit is a tributary of the Orange River with its confluence approximately 60 km (linear distance) upstream of Aliwal North. The Sterkspruit sewage treatment plant is located approximately 6 km (linear distance) south-east of the Kromspruit-Orange River confluence.

Groundwater occurs as inter-granular and/or fractured zone aquifers. There are no high yield aquifers in a 1 km radius of the site that are developed. Groundwater is mainly used for livestock watering and domestic use where no surface water resources are available and that is not serviced by means of the local water reticulation network. The average yield of boreholes in the area is between 0.1 and 0.5 l/s.

The average rainfall in the area is between 600-700 mm per annum which occurs largely as thunderstorms between November and April. The surface water runoff in the area is typically restricted to very high rainfall events with an estimate mean annual runoff of between 100 – 200 mm per annum (Water Resources of South Africa, 2005 Study, WR2005)

The replacement of the sewage bulk connector systems entail division of the systems into three major drainage zones, one for each community. The replacement will aim to maximise the delivery of sewer services to the communities. The communities of Sterkspruit, Esilindini, Tapoleng and Mokhesi will all be serviced and connected to the WWTW by these bulk connector systems.

The sewer connector services will consist out of the following infrastructure:

- The construction of 1200 m of 160 mm diameter sewer pump lines.
- The construction of 6000 m of 200 mm diameter sewer pipes.
- The construction of 12000 m of 250 mm diameter sewer pipes.
- The construction of 5000 m of 355 mm diameter sewer pipes.
- The construction of 2000 m of 400 mm diameter sewer pipes.
- The construction of 350 manholes.

The WWTW will be replaced and will have an initial capacity of 2MI per day. The final effluent will be irrigated onto sports fields and other designated irrigation areas. This 2MI capacity will be sufficient for 5 years and will accommodate all excess sewage that the current WWTW cannot handle. After the 5 year period the WWTW will be upgraded to handle 6MI per day. During this upgrade the re-use of the final effluent will be investigated or the installation of an outfall sewer to evaporation dams will be investigated.

The WWTW will consist of amongst others:

- Inlet works with screening and de-gritting
- Flow measurements
- Biological reactor
- Secondary sedimentation tanks
- Maturation rivers

The process that will be used for the WWTW will be the well known and proven "three-stage Phoredox" activated sludge treatment process.

The main objective will be to re-use as much of the water for irrigation of fodder, town gardens and sport fields.

The eventual 6 MI per day WWTW will be constructed over three phases:

Flow description	Phase 1	Phase 2	Phase 3
Description of work	2.5MI/d inlet works, 3460m ³ reactor, 22 m diameter Secondary Sedimentation Tanks (SST) with chlorination channels, chlorination building, control building	Petro division box, facultative pond 2500 m ³ , Petro recycle pump station and pipe work	Mirror of phase 1 and 2. Construct 5 MI/d inlet works, additional 3460 m ³ reactor, additional 22 m diameter SST with chlorination channels (30 min contact time)
Structures shared from previous phases		Share 2.5 MI/d inlet works, chlorination channels, chlorination building and control building	Share chlorination building and control building
ADWF	1712 m ³ /d	2440 m ³ /d	4880 m ³ /d

capacity			
PDWF	4491 m ³ /d	6037 m ³ /d	12 635 m ³ /d
Number of stands	3058 stands	4366 stands	8732 stands

The different components and stages within the WWTW will consist of:

- Inlet works where raw sewage will enter the plant from the bulk connector system.
- Reactors which will facilitate aeration by means of six vertical shaft aerators.
- Secondary Settling Tanks (SST) which will enable settling of solids and separation of water.
- Petro system oxidation secondary ponds which will enable aerobic sludge digestion which will further aid in an increase in sludge storage capacity.
- Effluent from the chlorination basin will be discharged through a series of maturation channels. The channels will be shaped according to the natural contours on the site. The channels are approximately three meters wide with a maximum depth of 300 mm. These channels will be planted with reed.
- Gas chlorination will be done with auto-change over and in accordance with SANS requirements.

The site currently contains an oxidation pond. New sludge lagoons will be constructed on top of this oxidation pond. Upon consultation between the engineers and the municipality it has been concluded that the local Sterkspruit landfill site does not currently have capacity for the accumulated sludge within the existing oxidation ponds. The best course of action for the construction of the new sludge lagoons will be to rehabilitate the current oxidation pond by means of capping the existing oxidation pond and constructing the new sludge lagoons on top. In this manner the existing oxidation pond will be contained within capped clay layers which will prevent infiltration and pollution of the groundwater as well as the surrounding environment. The following figure should illustrate this:

Existing oxidation pond:

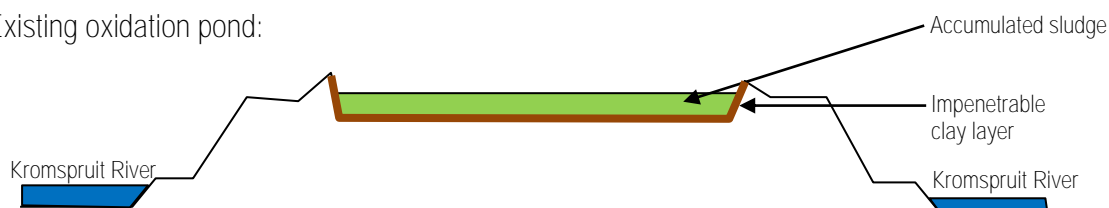

Rehabilitated oxidation pond and newly constructed sludge lagoon:

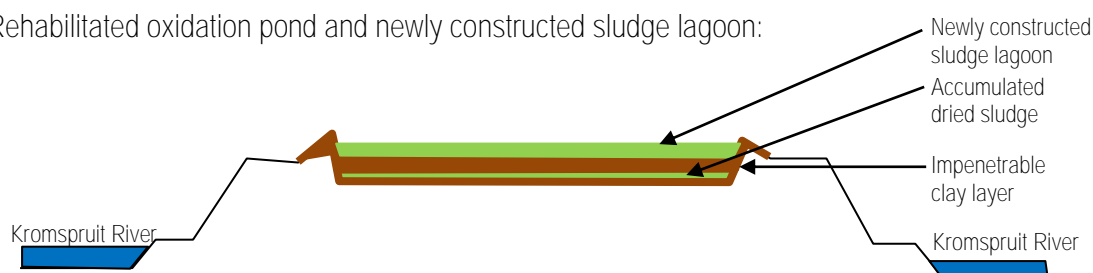

The newly constructed sludge lagoon will have a lifetime of 20 years before it will require de-sludging. This will be the only period when the WWTW will produce solid waste. The expected volume of sludge to be disposed of at this time will be approximately 500 m³. This sludge waste will then be disposed of in accordance with the Department of Water and Sanitation, Guideline for Permissible Utilisation and

Disposal of Wastewater Sludge Volume 3: Requirements for the on-site and off-site disposal of sludge (2009) which is currently available or whichever may be available at that time. The possible options for the disposal include the current new landfill site which is still in the planning phase and which can be investigated for the disposal of the sludge. Alternatively sludge may then be used as fertiliser on surrounding fields.

A series of lift pump stations will also be constructed to accommodate the bulk connector services where gravitational feeds cannot carry any raw sewage to the WWTW. A total of 7 sewer lift pump stations will be constructed along bulk connector systems.

The following specifications will be applicable to the pump stations:

- 20-hour pumping per day.
- Sized for the summer peak demand
- Sized for a minimum of 33% standby capacity.

Due to the fact that the existing WWTW is overloaded at present it is of critical importance that the construction of the new WWTW commence. From the once-off water quality data and a visual assessment of the river status it is clear that the spruit are affected by sub-standard water from sewage origin enter the system. This is mainly overflows as a result of overflow from sewage blockages, runoff from poorly reticulated areas and the seepage from the existing maturation ponds.

The upgrade of the Sterkfontein STP will have a significant positive impact on the general river health in the Kromspruit. For detailed specifications and description of the WWTW and associated pipelines please refer to Appendix G and the technical feasibility report.

Discussion on the assessed alternatives:

Alternative 2 – Oxidation ponds

This alternative will entail the use of oxidation ponds exclusively for treatment of sewage and the WWTW will not be upgraded to an activated sludge system. The alternative will entail several other impacts which renders it unfeasible.

Firstly an oxidation pond WWTW will require a large surface area (Approximately 15 ha) which is not present on the site and there is therefore not enough surface area to construct such a WWTW. The large surface area to be transformed will also have a much higher impact on the vegetation and fauna of the area.

This alternative will also entail oxidation pond treatment which has been proven to be much less effective than activated sludge treatment. The treated water will therefore have much higher levels of pollution after treatment. It will then not be possible to release the treated water back into the Kromspruit. The treated water will have to be irrigated on crop fields or grazing. The area has been urbanised and does not contain any such areas in close proximity. It will therefore not be possible to irrigate the treated water.

Due to the above constraints it will not be possible to implement this alternative.

Discussion on the 'no-go' alternatives:

The current WWTW has reached capacity several years ago and the infrastructure is no longer able to service the Sterkspruit area. The area does not contain any pipeline infrastructure and the small portion of existing pipeline is exceedingly dilapidated and is causing leakage of sewage into groundwater and surface water resources. The population of Sterkspruit require adequate Waste Water Treatment Works and the capacity of the current WWTW must be enlarged. The no-go alternative would entail a higher environmental impact than the construction of the new WWTW. The current oxidation ponds and pipeline infrastructure is causing raw sewage to leak into the groundwater and surface water resources. The construction of the new WWTW and pipeline infrastructure will improve these impacts.

After consideration of the Environmental Impact Assessments the following conclusions are drawn:

The likelihood of significant expected impacts actually occurring is highly unlikely and limited if recommended mitigation measures are implemented throughout the phases of the project.

The proposed site is already transformed, highly degraded and cannot be considered to be of significant conservation value. The site which will be affected by the WWTW is already highly disturbed and the anticipated impacts caused by the construction will not cause a high disturbance of the site since it is already highly disturbed.

The site is subjected to numerous impacts which include the following. The area is subjected to heavy and sustained overgrazing which has lead to significantly low vegetation cover which in turn leads to greater runoff, increased erosion and high sediment loads. The area contains a moderate density but expansive area of residential and light industrial development. This area is also highly affected by insufficient sewage systems and is highly affected by rubbish dumping and littering. As a result the runoff from these residential areas is highly polluted and has a high impact on the Kromspruit. These areas also lack surface cover in the form of vegetation or paving. As a result the area is subjected to high erosion, increased sediment loads and increased runoff which further negatively impacts on the Kromspruit. The existing WWTW has oxidation ponds where sewage is being pumped into. These ponds are inadequate and leaking and as a result highly polluted water enters the Kromspruit and causes high levels of pollution, algal blooms and consequently eutrofication of the river. The Kromspruit is also subjected to several other impacts including bridge crossing of roads, abstraction for irrigation, polluted runoff from irrigated and dryland crop cultivation, rubbish dumping and excavation of material from the river.

It is anticipated that the establishment of the new WWTW will alleviate and improve the current conditions as the treated water will be of better quality and the oxidation ponds will be upgrading and re-constructed so that leakages into the Kromspruit no longer take place.

Impacts that will be associated with the Construction Phase will be temporary in nature. Although the activities that will be associated with the Operational Phase will be permanent it should be clear from the above as well as the nature of the development that the potential impacts associated with this phase will be minimal and local in nature. The likelihood of potential impacts occurring during the operational phase is highly unlikely.



water & sanitation

Department:
Water and Sanitation
REPUBLIC OF SOUTH AFRICA

Private Bag X313, Pretoria 0001, 185 Francis Baard Street, Sedibeng Building, Pretoria,
Tel: 012 336 7500, Fax: (012) 323 4472/ (012) 326 2715. www.dws.gov.za

LICENCE IN TERMS OF CHAPTER 4 OF THE NATIONAL WATER ACT, 1998 (ACT NO. 36 OF 1998)

I, **Sifiso Mkhize**, in my capacity as Director-General (Acting) in the Department of Water and Sanitation and acting under authority of the powers delegated to me by the Minister of Water and Sanitation hereby authorise the following water uses in respect of this licence.

SIGNED: _____

DATE: 17 | 05 | 2018

LICENCE NO: 10/D12B/F/6730
FILE NUMBER: 27/2/2/D212/3/9

1. **Licensee**
Postal Address
Joe Gqabi District Municipality (Sterkspruit Waste Water Treatment Works)
Private bag X102
Barkly East
9786
2. **Water Uses**
 - 2.1 Section 21(f) of the Act: Discharging waste or water containing waste into a water resource, subject to the conditions set out in Appendices I and II.
 - 2.2 Section 21(c) of the Act: Impeding or diverting the flow of water in a water resource, subject to the conditions as set out in Appendices I and III.
 - 2.3 Section 21(i) of the Act: Altering the bed, banks, course or characteristics of a water resource, subject to the conditions as set out in Appendices I and III.
3. **Properties in respect of which this licence is issued**
 - 3.1 Sterkspruit Erf 1
 - 3.2 Remainder of Esilindini 68
 - 3.3 Remainder of Sterkspruit 82
4. **Registered owner of the Property**
 - 4.1 Senqu Local Municipality

B 11478

5. Licence and Review Period

- 5.1 This licence is valid for a period of twenty (20) years from the date of issuance and it may be reviewed at intervals of not more than five (5) years.

6. Definitions

“Any word or term defined under the National Water Act, 1998 (Act 36 of 1998) shall have the same meaning as defined in the Act, unless otherwise specifically stated.”

“The Provincial Head” means Head of Provincial Operations: Free State, Department of Water and Sanitation, Private Bag X528, Bloemfontein, 9300”.

“Department” means Department of Water and Sanitation

“Minister” means Minister of Department of Water and Sanitation

“The Act” means the National Water Act, 1998 (Act 36 of 1998)

“WWTWs”- Waste Water Treatment Works

7. Description of activity

The proposed activity entails upgrading of the Sterkspruit WWTWs to a 6ML of effluent per day. The total volume of 2 190 000 m³/a, of treated effluent will be discharged in to the Kromspruit which is a tributary of the Orange River. The WWTW is located within the D12B quaternary catchment in the Orange Water Management Area. The geographic location is S30⁰ 31' 04.2", E27⁰ 22' 08.9".

APPENDIX I

1. This licence is subject to all applicable provisions of the National Water Act, 1998 (Act 36 of 1998).
2. The responsibility for complying with the provisions of the licence is vested in the Licensee and not any other person or body.
3. The Licensee must immediately inform the Provincial Head of any change of name, address, premises and/or legal status.
4. If the property in respect of which this licence is issued is subdivided or consolidated, the Licensee must provide full details of all changes in respect of the properties to the Provincial Head of the Department within 60 days of the said change taking place.
5. If a water user association is established in the area to manage the resource, membership of the Licensee to this association is compulsory.
6. The Licensee shall be responsible for any water use charges or levies imposed by a Responsible Authority.
7. While effect must be given to the Reserve as determined in terms of the Act, where a desktop determination of the Reserve has been used in issuance of a licence, when a comprehensive determination of the Reserve has finally been made; it shall be given effect to.
8. The licence shall not be construed as exempting the Licensee from compliance with the provisions of any other applicable Act, Ordinance, Regulation or By-law.
9. The licence and amendment of this licence are also subject to all the applicable procedural requirements and other applicable provisions of the Act, as amended from time to time.
10. The Licensee shall conduct an annual internal audit on compliance with the conditions of licence. A report on the audit shall be submitted to the Provincial Head within one month of the finalisation of the audit.
11. The Licensee shall appoint an independent external auditor to conduct an annual audit on compliance with the conditions of this licence. The first audit must be conducted within 3 (three) months of the date of issuance of this licence and a report on the audit shall be submitted to the Provincial Head within one month of finalisation of the report.
12. Flow metering, recording and integrating devices shall be maintained in a sound state of repair and calibrated by a competent person at intervals of not more than two years. Calibration certificates shall be available for inspection by the Provincial Head or his| her representative upon request.
13. Any incident that causes or may cause water pollution must be reported to the Provincial Head or his/her designated representative within 24 hours.
14. Prior to the approval of any new development, the Licensee must check and verify the capacity and adequacy of available wastewater infrastructure to ensure that the systems can handle the additional load arising from the new development.

APPENDIX II

Section 21(f) of the Act: Discharging waste or water containing waste into a water resource

1. QUANTITY OF WATER CONTAINING WASTE

- 1.1 This licence authorises Joe Gqabi District Municipality: Sterkspruit WWTWs to treat and discharge of a maximum quantity of two million one hundred and ninety thousand cubic metres per annum (2 190 000 m³/a) of water containing waste based on an average of 6 000 m³/d (six thousand cubic metres per day) into the Kromspruit located at **S: 30° 31' 04.2"** and **E: 27° 22' 08.9"**.
- 1.2 The quantity of water containing waste authorised to be discharged of in terms of this licence must not be exceeded

2. QUALITY OF WATER CONTAINING WASTE DISCHARGED

- 2.1 The quality of water containing waste discharged into the Kromspruit may not exceed the following values or range shown in Table 1.

Table 1: showing limits recommended for discharge into Kromspruit

Variable	Limits
pH	5.5-9.5
Electrical Conductivity EC	75 mS/m
Chemical Oxygen Demand	75 mg/l
Suspended Solids	25 mg/l
Free saline Ammonia	10 mg/l
Orthophosphate as N	10 mg/l
E.coli (counts per 100ml)	0
Temperature	25 ^o C
Dissolved Oxygen	<5
Soap, grease or oil	2.5 mg/l
Nitrate (as N)	<6 mg/l
Residual Chlorine	0.35 mg/l
Faecal Coliforms (per 100 ml)	1000 mg/l

3. MONITORING

3.1. Quantity

- 3.1.1. The quantity of the water containing waste discharged into the Kromspruit must be metered and recorded daily.
- 3.1.2. Monitoring for the quantity of water containing waste shall be done at the inlet of the WWTWs.
- 3.1.3. Flow metering, recording and integrating devices shall be maintained in a sound state of repair and calibrated by a competent person at intervals of not more than two years or as the design specifications. Calibration certificates shall be available for inspection by the Provincial Head representative upon request.

3.2 Quality of the water containing waste

- 3.2.1 Monitoring points for quality must be at the outlet of the WWTWs, and at the upstream and downstream of the discharge point in Kromspruit.
- 3.2.2 The monitoring points shall not be changed without prior notification to and written approval by the Provincial Head.
- 3.2.3 The quality of the water containing waste shall be monitored by taking grab samples every month at the monitoring points described in condition 3.2.1 of Appendix II. Each sample shall be analysed according to condition 4.1 of Appendix II for the variables, shown in Table 2 in Appendix II and/or any other variable as may be required from time by the Provincial Head.

Table 2: Variables to be monitored and monitoring Frequency

Variable	Frequency
pH	Monthly
Electrical Conductivity EC	Monthly
Chemical Oxygen Demand	Monthly
Suspended Solids	Monthly
Ammonia	Monthly
Nitrate/Nitrite	Monthly
Orthophosphate	Monthly
E.Coli (counts per 100ml)	Monthly
Soap, grease or oil	Monthly
Residual Chlorine	Monthly
Dissolved Oxygen	Monthly
Faecal Coliforms	Monthly

- 3.2.4 The date, time and monitoring point in respect of each sample taken shall be recorded together with the results of the analysis.
- 3.2.5 The Licensee must summarise surface water quality data and interpretation thereof in an annual report to be submitted to the Provincial Head for the purposes of quantifying the potential impact of the Sterkspruit Wastewater Treatment Works.

3.3 Bio-Monitoring

- 3.3.1 The Licensee must develop and submit a bio-monitoring programme to the Provincial Head within six (6) months of issuance of this licence which include the compilation of an initial database from which the scope and frequency of future bio-monitoring can be developed. This initial assessment must lead to the establishment of a reliable site-specific long-term bio-monitoring programme. This programme must be able to qualify and quantify the impact on biological systems in the water environment in the area directly affected by WWTWs activities as well as downstream from these activities.
- 3.3.2 A competent and capable aquatic scientist must be appointed by the Licensee to submit a monitoring programme for aquatic macro-invertebrates and habitat integrity. Aquatic macro-invertebrates must be sampled using the latest SASS (South African Scoring System) method. Habitat Integrity must be assessed using the Rapid Bio-assessment Analysis (C.J. Kleynhans 1999) method described by the Department (SASS 2002).

4. METHODS OF ANALYSIS

- 4.1 Analyses shall be carried out in accordance with methods prescribed by and obtainable from the South African Bureau of Standards, in terms of the Standards Act, Act 30 of 1982.
- 4.2 The methods of analysis shall not be changed without prior notification to and written approval by the Provincial Head.

5. REPORTING

- 5.1.1 The information required in terms of condition 3 of Appendix II shall be submitted monthly to the Provincial Head, under reference 27/2/2/D212/3/9 within one month of the close of the period concerned.
- 5.2 Information submitted must be graphically analysed to illustrate trends in the compliance of the effluent with the standards.
- 5.3 The occurrence of any incident which causes or may cause water pollution must be immediately reported to the Provincial Head.

6. STORMWATER MANAGEMENT AND DISPOSAL

- 6.1 Stormwater leaving the Licensee's premises must not be contaminated by any substance, whether such substance is a solid, liquid, vapour or gas or a combination thereof which is produced, used, stored, dumped or spilled on the premises.
- 6.2 No effluent shall be discharged into any storm water drain or furrow, whether by a positive act and/or by omission.
- 6.3 The licensee must submit stormwater management plan must be submitted for approval within three (3) of the issuance of this licence.
- 6.4 No stormwater from any development should be connected to the sewer pipeline connected to the WWTWs. The Licence must monitor illegal connection of the stormwater into the sewer pipeline.
- 6.5 The stormwater around the WWTWs must be diverted away from before the head of the works to avoid flooding of the WWTWs.
- 6.6 All stormwater management facilities within the site must be lined to reduce the deposition of sediments in the plant and separation of the clean and dirty water.
- 6.7 All manholes and sewer pipelines connected to the plan must be sealed to avoid ingress of the stormwater and run-off.

7. POLLUTION PREVENTION

- 7.1. Pollution caused by spills either accidental or from mechanical or electrical breakdown or power disruptions must be prevented through proper maintenance and effective protective measures.
- 7.2. All reagent and chemical storage areas must be supplied with a banded area built to the capacity of the facility and provided with sumps and pumps to contain the spilled material. The system shall be maintained in a state of good repair and standby pumps must be provided.

- 7.3 Any hazardous substances must be handled according to the relevant legislation relating to the transport, storage and use of the substance.
- 7.3 All sewage spills must be contained on site and directed back to the works for further treatment. All areas affected must be rehabilitated.
- 7.4 All waste (screenings) must be disposed in the bin and disposed in licence land fill. A service agreement between the applicant and service provider must be on site all the time.
- 7.5 An emergency response plan must be developed and used during all emergencies on plant.
- 7.6 Where possible the licensee must construct to two screening area to avoid spilling of raw sewage when the one screening area of works is blocked or during the maintenance of the works.

8 ACCESS CONTROL

- 8.1. Strict access procedures must be followed in order to gain access to the properties. Access to the Sterkspruit Wastewater Treatment works must be limited to authorised employees of the Licensee and their Contractors only.
- 8.2. Notices prohibiting unauthorised persons from entering the areas referred to in condition.
- 8.2. As well as internationally acceptable signs in three official languages used in the area indicating the risks involved in case of an unauthorised entry must be displayed along the boundary fence of these areas.

9. CONTINGENCIES

- 9.1. Accurate and up-to-date records shall be kept of all system malfunctions resulting in non-compliance with the requirements of this licence. The records shall be available for inspection by the Provincial Head upon request. Such malfunctions shall be tabulated under the following headings with a full explanation of all the contributory circumstances:
 - 9.1.1 operating errors;
 - 9.1.2 mechanical failures (including design, installation or maintenance);
 - 9.1.3 environmental factors (e.g. flood);
 - 9.1.4 loss of supply services (e.g. power failure); and
 - 9.1.5 other causes.
- 9.2. The Licensee must notify the Provincial Head within 24 hours of the occurrence or potential occurrence of any incident which has the potential to cause, or has caused water pollution, pollution of the environment or health risks or which is a contravention of the licence conditions.
- 9.3. The Licensee must submit an action plan within 14 days to the Provincial Head which assesses the occurrence or detection of any incident referred to above.
- 9.4. The action plan must include a detailed time schedule that meets with the satisfaction of the Provincial Head of measures taken to:
 - 9.4.1 correct the impacts resulting from the incident;
 - 9.4.2 prevent the incident from causing any further impacts; and
 - 9.4.3 prevent a recurrence of a similar incident.

10 OPERATION OF THE SEWAGE PURIFICATION WORKS

- 10.1. The wastewater treatment works must be supervised and controlled by a suitably qualified and experienced employee of the Licensee who shall have under his/her control an adequate number of process controllers who have been classified in terms of regulation 2834 dated 27 December 1985 (or any update thereto) and in terms of section 26 of the Act, to ensure proper functioning of the works and processes at all times.
- 10.2. Suitably qualified and experienced mechanical and electrical artisans shall be available to be called in for inspection and maintenance of the works.

11. PIPELINES

- 11.1 Pipelines used for the conveyance of effluent must be painted in a conspicuous colour or manufactured of a coloured material distinctly different from the colour of the pipelines in which drinking water is flowing to avoid the possibility of any cross-connections of different pipelines.
- 11.2 All stop-valves and taps on the pipelines conveying water containing waste must be of a type that can be opened and closed by means of a loose wrench. This wrench must be in the safekeeping of a responsible member of the staff to prevent unauthorised use thereof.
- 11.3 Pollution caused by spills from the conveyances must be prevented through proper maintenance and effective protective.
- 11.4 Any hazardous substances must be handled according to the relevant legislation relating to the transport, storage and use of the substance.

12. PUMP STATIONS

- 12.1 The Licensee shall develop and implement a scheduled monitoring and maintenance plan for all wastewater pump stations and manholes under its control.
- 12.2 All pump stations shall have an emergency containment facility with sufficient capacity to ensure untreated effluent retention up to a 24-hour period.

13. MANHOLES

- 13.1 The Licensee must ensure that:
 - 13.1.1 Manholes are covered at all times with a suitable cover that cannot be removed by unauthorised persons;
 - 13.1.2 Manhole covers of a material that is less prone to theft are used.
 - 13.1.3 No new WWTWs lines and manholes are constructed in the 1:100 year flood line and
 - 13.1.4 Existing WWTWs lines and manholes situated within the 1:100 year flood lines are sealed adequately to ensure minimal ingress of water during any rainfall event.

14. MALFUNCTIONS/ABNORMAL CONDITIONS

- 14.1 Accurate and up-to-date records must be kept of all system malfunctions resulting in non-compliance with the requirements of this licence. The records must be available for inspection by the Provincial Head upon request.
- 14.2 The records shall be tabulated under the following headings with a full explanation of all the contributory circumstances:

- 14.2.1 Operating errors
 - 14.2.2 Mechanical failures (including design, installation or maintenance)
 - 14.2.3 Environmental factors (e.g. floods)
 - 14.2.4 Loss of supply services (e.g. power failure)
 - 14.2.5 Other causes
- 14.3 The Licensee must, within 14 days, or a shorter period of time, as specified by the Provincial Head, from the occurrence or detection of any incident referred above, submit an action plan, which must include a detailed time schedule, to the satisfaction of the Provincial Head of measures taken to:
- 14.3.1 Correct the impacts resulting from the incident;
 - 14.3.2 Prevent the incident from causing any further impacts; and
 - 14.3.3 Prevent a recurrence of a similar incident.
- 14.4 The Licensee must notify by the Provincial Head within 24 hours of the occurrence or potential occurrence of any incident which has the potential to cause, or has caused water and environmental pollution, health risks or which is a contravention of the licence conditions.
- 15. GENERAL**
- 15.1. No intractable or toxic waste, which may deleteriously affect the efficient functioning of the wastewater treatment works or the quality of the final discharge, shall be received in the wastewater treatment works.
- 15.2. The Licensee shall take all steps possible including the administration of wastewater and industrial effluent bylaws to prevent the discharge of any substance into the sewerage system which is connected to the wastewater treatment works, and which could have a deleterious effect on the operation of works and/or the final discharge of water containing waste to the tributary Orange River.

APPENDIX III

Section 21(c) of the Act: Impeding or diverting the flow of water in a watercourse and
Section 21(i) of the Act: Altering the bed, banks, course or characteristic of a watercourse

1. GENERAL

1.1 This licence authorises Joe Gqabi District Municipality for the construction, operation and maintenance of Section 21(c) and (i) water use activities as set out in Table 3 and in the water use licence application reports submitted to the Responsible Authority.

Table 3: Summary of water uses applied for:

Water use(s)	Purpose	Capacity/ Volume (m³, tonnes and/or m³/annum)	Property Description	Co-ordinates
21(c) & (i)	Attachment of sewer pipeline on the existing road across the Kromspruit	N/A	Sterkspruit Erf 1	S: 30 ⁰ 31' 37.10" E: 27 ⁰ 22' 32.10"
21(c) & (i)	Construction of a sewer pipeline across a seasonal stream at R392 road	N/A	Remainder of Esilindini 68	S: 30 ⁰ 31' 11.88" E: 27 ⁰ 22' 45.83"
21(c) & (i)	Construction of a sewer pipeline across a drainage line at R392 road	N/A	Remainder of Esilindini 68	S: 30 ⁰ 31' 05.27" E: 27 ⁰ 22' 45.83"
21(c) & (i)	Construction of a sewer pipeline across a drainage line at Wittenberg suburb	N/A	Remainder of Sterkspruit 82	S: 30 ⁰ 32' 36.28" E: 27 ⁰ 22' 44.90"
21(c) & (i)	Construction of a sewer pipeline across a seasonal stream at R392 road	N/A	Remainder of Sterkspruit 82	S: 30 ⁰ 31' 45.87" E: 27 ⁰ 20' 53.69"
21(c) & (i)	Construction of a sewer pipeline across a seasonal stream at Tienbank suburb	N/A	Remainder of Sterkspruit 82	S: 30 ⁰ 32' 06.75" E: 27 ⁰ 20' 48.18"
21(c) & (i)	Construction of a sewer pipeline across a seasonal stream at Mfirikini suburb	N/A	Remainder of Esilindini 68	S: 30 ⁰ 32' 41.02" E: 27 ⁰ 20' 38.56"
21(c) & (i)	Construction of a sewer pipeline across a seasonal stream	N/A	Remainder of Esilindini 68	S: 30 ⁰ 32' 59.17" E: 27 ⁰ 20' 18.49"

Water use(s)	Purpose	Capacity/ Volume (m ³ , tonnes and/or m ³ /annum)	Property Description	Co-ordinates
	at Mfirikini suburb			
21(c) & (i)	Construction of a sewer pipeline across a drainage line at Etshantolo suburb	N/A	Remainder of Esilindini 68	S: 30° 33' 05.33" E: 27° 19' 39.23"
21(c) & (i)	Construction of a sewer pipeline across a drainage line at the R392 road	N/A	Remainder of Esilindini 68	S: 30° 31' 58.95" E: 27° 20' 34.87"
21(c) & (i)	Construction of a sewer pipeline across a seasonal stream at the R392 road	N/A	Remainder of Esilindini 68	S: 30° 32' 11.72" E: 27° 18' 58.33"

- 1.2 The licensee must carry out and complete all the activities listed under condition 1.1 according to the following:
- 1.2.1. The river crossing drawing, referenced DIB 106-2016 for Sterkpruit RBIG Bulk Sewerage project, by Dibanani Consulting Engineers, in the water use licence application provided to the Department.
- 1.3 The conditions of the authorisation must be brought to the attention of all persons (employees, sub-consultants, contractors etc.) associated with the undertaking of these activities and the licensee must take such measures that are necessary to bind such persons to the conditions of this licence.
- 1.4 A suitably qualified person(s), appointed by the licensee, and approved in writing by the Provincial Head: Free State must be responsible for ensuring that activities are undertaken in compliance with the specifications as set out in reports submitted to the Department or the Responsible Authority and the conditions of this licence.

2. FURTHER STUDIES AND INFORMATION REQUIREMENTS

- 2.1 For water use activities in Table 3:
- 2.1.1. No fundamental alterations of the work method statements, site plan(s) and drawings are allowed, unless a modification is requested and granted by the Provincial Head in writing; and
- 2.2 If the Licensee is not the end user/beneficiary of the water use related infrastructure and will not be responsible for long term maintenance and management of the infrastructure, the Licensee must provide a programme for hand over to the successor-in-title including a brief management/maintenance plan and the agreement for infrastructure along with allocation of responsibilities, within three (3) months of the date of issuing of this licence.
- 2.3 For the activity listed under condition 1.1, Table 3, "as-built" plan(s) and engineering drawing(s) prepared by a registered professional engineer, must be submitted to the Provincial Head within six (6) months of completion of activity. These plan(s) and

drawing(s) must indicate the watercourse(s) including wetland boundaries and layout and structure location(s) of all infrastructure impeding and/or diverting flow of watercourses as well as alterations to watercourse(s) on the properties.

- 2.4 Pipeline Maintenance Plan must be submitted within one month of issuance of this licence.

3. PROTECTIVE MEASURES

3.1 General Conditions on Stormwater Management

- 3.1.1 Stormwater shall be diverted from the construction works and roads and shall be managed in such a manner as to disperse runoff and to prevent the concentration of stormwater flow.
- 3.1.2 Where necessary works must be constructed to attenuate the velocity of the stormwater discharge and to protect the banks of the watercourse.
- 3.1.3 Stormwater control works must be constructed, operated and maintained in a sustainable manner throughout the project.
- 3.1.4 Increased runoff due to vegetation clearance and/or soil compaction must be managed, and steps must be taken to ensure that stormwater does not lead to bank instability and excessive levels of silt entering the watercourse.

4. WATER USE ACTIVITIES IN RELATION TO THE CHARACTERISTICS OF A WATERCOURSE

4.1 Water Quality

- 4.1.1 The licensee must ensure that the quality of the water to downstream water users does not decrease because of the water use activities listed under condition 1.1.
- 4.1.2 In-stream water quality must be analysed on a two-weekly basis during construction otherwise monthly at monitoring points both upstream and downstream of the activities for the following variables, but not limited to:
- 4.1.2.1 Suspended solids (mg/l) : <20 mg/l;
 - 4.1.2.2 Total dissolved Solids (mg/l) : <450MG/l;
 - 4.1.2.3 Dissolved Oxygen (mg/l) : <6mg/l and
 - 4.1.2.4 Turbidity (NTU): <3NTU
- 4.1.3. Monitoring must be undertaken as set out in condition 4.
- 4.1.4. Monitoring must continue for 3 years after cessation of the activities listed in condition 1.1.
- 4.1.5 Turbidity, sedimentation and chemical changes to the composition of the water must be limited and monitored both upstream and downstream of activities.
- 4.1.6 Activities that lead to elevated levels of turbidity of any watercourse must be minimised. Activities must be scheduled to take place during the dry seasons when flows are lowest where reasonably possible. If this is not possible and if management measures have not been provided for activities in a wet season in the reports submitted to the Department or the Responsible Authority, the licensee must submit such to the Regional Chief Director for written approval before these activities commence. Natural in-stream hydrology is to be used to determine which months constitute the low flow months.

- 4.1.7 Pollution of and disposal/spillage of any material into the watercourse must be prevented, reduced, or otherwise remediated through proper operation, maintenance and effective protective measures.
- 4.1.8 Vehicles and other machinery must be serviced well above the 1:100 year flood-line or outer edge of the riparian habitat whichever is the greatest. Oils and other potential pollutants must be disposed off at an appropriate licensed site, with the necessary agreement from the owner of such a site.
- 4.1.9 Any hazardous substances must be handled according to the relevant legislation relating to transport, storage and use of the substance.
- ~~4.1.10 No material with pollution generating potential will be used in any of the operation and maintenance activities.~~
- 4.1.11 All reagent storage tanks and reaction units must be supplied with a bunded area built to the capacity of the facility and provided with sumps and pumps return the spilled material back into the system. The system must be maintained in a state of good repair and standby pumps must be provided.

4.2 Flow

- 4.2.1 The water use must not result in a change in the quality, velocity, pattern, timing water level and assurance of flow in the watercourse.
- 4.2.2 The licensee must ensure that the overall magnitude and frequency of flow in the water course/s does not decrease, other than for natural evaporative losses and authorised attenuation volumes.
- 4.2.3 Increased run-off during construction must be managed using berms and other suitable structures as required to ensure flow velocities are reduced, special care must be given to ensure velocity is slowed before reaching the watercourse.

4.3 Riparian Habitat (Vegetation and Morphology)

- 4.3.1 Activities must start up-stream and proceed into a down-stream direction, so that the recovery processes can start immediately, without further disturbance from upstream works.
- 4.3.2 The proposed construction should not increase bank instability and the erosive potential of a stream. Steps should be taken to ensure that the channel is able to withstand the most probable maximum flood events without undue bank instability or erosion.
- 4.3.3 Operation and storage of equipment within the riparian habitat must only take place within the approved limits of disturbance indicated in an approved site plan and work method statements.
- 4.3.4 Activities must not occur in sensitive riffle habitats or where there are rock outcrops.
- 4.3.5 Indigenous riparian vegetation, including dead trees, outside the limits of disturbance indicated in the site plans, referred to in condition 2, may not be removed from the area.
- 4.3.6 Removal of riparian forest must be authorised in terms of the National Forest Act (Act No. 84 of 1998).

- 4.3.7 The vegetation of the surrounding catchment on the property must also be managed to prevent erosion and siltation of the watercourse.
- 4.3.8 Alien and invader vegetation must not be allowed to further colonise the area, and all new alien vegetation recruitment must be eradicated or controlled, using standard methods approved by the Department.
- 4.3.9 Existing vegetation composition in riparian zones by maintaining the natural variability in flow fluctuations must be maintained.
- 4.3.10 Recruitment and maintaining of a range of size classes of dominant riparian species in perennial channels must be stimulated.
- 4.3.11 Encroachment of additional exotic species and terrestrial species in riparian zones must be discouraged.
- 4.3.12 Accumulation of woody debris on terraces by periodic flooding must be discouraged.
- 4.3.13 Existing flood terraces and deposition of sediments on these terraces to ensure optimum growth, spread and recruitment of these species must be maintained.
- 4.3.14 All reasonable steps must be taken to minimise noise and mechanical vibrations in the vicinity of the watercourses.
- 4.3.15 The necessary erosion prevention mechanisms must be employed to ensure the sustainability of all structures and activities and to prevent in stream sedimentation.
- 4.3.16 Soils that have become compacted through the water use activities must be loosened to an appropriate depth to allow seed germination.
- 4.3.17 Slope/bank stabilisation measures must be implemented.
- 4.3.18 Stockpiling of removed soil and material must be stored outside of the 1:100 year flood line or riparian habitat, whichever is the greater, to prevent being washed into the watercourse and must be covered to prevent wind and rain erosion.
- 4.3.19 The indiscriminate use of machinery within the in stream and riparian habitat may lead to compaction of soils and vegetation and must therefore be strictly controlled.

4.4 Biota

- 4.4.1 The licensee must take all reasonable steps to allow movement of aquatic species, including migratory species.
- 4.4.2 All reasonable steps must be taken not to disturb the breeding, nesting and/or feeding habitats and natural movement patterns of aquatic biota.
- 4.4.3 The current level of diversity of biotopes and communities of animals, plants and microorganisms must be maintained.

5. GENERAL SPECIFICATIONS

- 5.1 A suitably qualified person, appointed by the licensee, and approved, in writing, by the Provincial Head, must be responsible for ensuring that the structure is constructed, operated and maintained in line with the design specifications.

- 5.2 The licensee must ensure that the pipeline shall not be damaged excessively by floods exceeding the magnitude of floods occurring on average once in every 100 years.
- 5.3 The necessary erosion prevention mechanisms shall be employed to ensure the sustainability of all the abstraction works and the pipeline.

6. PROTECTIVE MEASURES

- 6.1 All activities within the riparian zone should be restricted as far as possible.
- 6.2 Alien vegetation must not be allowed to further colonise the area, and all new alien vegetation recruitment must be eradicated or controlled, using standard methods approved by the Department.
- 6.3 Soils that have become compacted through the activities of the development must be loosened to an appropriate depth to allow seed germination.
- 6.4 Increased runoff due to vegetation clearance and/or soil compaction must be managed and steps must be taken to ensure that stormwater does not lead to the watercourse instability and excessive levels of silt entering the watercourse.
- 6.5 The extent of disturbance should be limited by limiting all construction activities to the development area as indicated on the general layout plan as far as practically possible.
- 6.7 As far as possible, the existing road and farm tracks should be used as the access road to provide access during construction as this will reduce the extent of the disturbed area.

7. REHABILITATION

- 7.1 All disturbed areas must be re-vegetated with an indigenous seed mix in consultation with an indigenous plant expert, ensuring that during rehabilitation only indigenous shrubs, trees and grasses are used in restoring the biodiversity.
- 7.2 The vegetation of the surrounding catchment should also be managed to prevent erosion and siltation of the watercourse including wetland/pan.
- 7.3 The licensee shall embark on a systematic long-term rehabilitation programme to restore natural watercourses (wetland/pan) to environmentally acceptable and sustainable conditions after construction, which shall include, but not be limited to:
 - 7.3.1 The rehabilitation of disturbed and degraded riparian areas to restore and upgrade the riparian habitat integrity to sustain a bio-diverse riparian ecosystem; and
 - 7.3.2 Annually assess the habitat to monitor the sustainability of the solar panels and compliance with these conditions. Action must be taken to rectify any negative impacts.
- 7.4 The licensee shall ensure that the volume of runoff to the wetlands/pans is not reduced or excessively increased except for natural evaporative losses and the authorised attenuation volumes.

8. GENERAL SURFACE WATER DESIGN REQUIREMENTS AND CRITERIA

- 8.1 The licensee shall clearly indicate all wetlands boundaries within the project area on layout plans.

- 8.2 Design and planning of all proposed construction activities adjacent to or in the vicinity of rivers, streams and wetlands shall consider the following measures:
- 8.2.1 Impact of alignment on springs and wetlands shall be investigated and monitored and ensure their continued functioning.
 - 8.2.2 Where appropriate, large individual indigenous riparian trees shall be avoided during construction and shall be clearly marked on site.
 - 8.2.3 All construction roads in or adjacent to the riparian zone shall be minimised and if required, shall be aligned and managed so as to minimise disturbance of the riparian zone and in-stream habitats.

9. BUDGETARY PROVISIONS

- 9.1 The water user must ensure that there is a budget sufficient to complete and maintain the water use and for successful implementation of the rehabilitation programme as set out in this licence.
- 9.2 The Department may at any stage of the process request proof of budgetary provisions.

[END OF LICENCE]

Bulk connector pipelines	
Phase 1 Pipeline	
S 30° 31' 07.30"	E 27° 21' 59.82"
S 30° 31' 22.54"	E 27° 21' 54.27"
S 30° 31' 26.05"	E 27° 22' 01.08"
S 30° 31' 42.01"	E 27° 21' 48.71"
S 30° 31' 45.42"	E 27° 21' 39.05"
S 30° 32' 18.27"	E 27° 21' 38.98"
S 30° 32' 23.85"	E 27° 21' 28.25"
S 30° 33' 10.32"	E 27° 21' 46.61"
S 30° 33' 13.36"	E 27° 21' 48.33"
S 30° 33' 04.26"	E 27° 21' 56.15"
S 30° 33' 29.84"	E 27° 22' 14.35"
S 30° 32' 04.69"	E 27° 22' 49.72"
S 30° 32' 15.54"	E 27° 22' 46.41"
S 30° 32' 27.44"	E 27° 22' 52.65"
S 30° 32' 34.73"	E 27° 22' 45.26"
S 30° 32' 36.94"	E 27° 22' 44.73"
S 30° 32' 42.96"	E 27° 22' 31.51"
Phase 2 Pipeline	
S 30° 31' 45.41"	E 27° 21' 39.08"
S 30° 31' 49.31"	E 27° 21' 21.48"
S 30° 31' 45.38"	E 27° 20' 54.03"
S 30° 31' 51.79"	E 27° 20' 39.00"
S 30° 32' 00.29"	E 27° 20' 20.17"
S 30° 32' 09.98"	E 27° 19' 52.51"
S 30° 32' 15.60"	E 27° 19' 05.12"
S 30° 32' 09.04"	E 27° 18' 54.52"
S 30° 31' 57.65"	E 27° 18' 46.29"
S 30° 32' 00.67"	E 27° 18' 22.89"
S 30° 32' 25.20"	E 27° 18' 53.02"
S 30° 32' 37.97"	E 27° 18' 54.59"
S 30° 32' 08.52"	E 27° 20' 49.82"
S 30° 32' 32.61"	E 27° 20' 46.87"
S 30° 32' 54.95"	E 27° 20' 17.77"
S 30° 33' 02.11"	E 27° 20' 19.02"
S 30° 33' 11.74"	E 27° 20' 10.30"
S 30° 32' 53.56"	E 27° 20' 11.21"
S 30° 32' 46.11"	E 27° 20' 06.09"
S 30° 32' 39.89"	E 27° 19' 58.00"
S 30° 32' 21.46"	E 27° 20' 11.06"
S 30° 33' 06.40"	E 27° 19' 38.28"
Phase 3 Pipeline	
S 30° 31' 35.96"	E 27° 22' 12.50"
S 30° 31' 23.61"	E 27° 22' 19.84"

S 30° 31' 12.52"	E 27° 22' 45.21"
S 30° 31' 18.65"	E 27° 23' 28.20"
S 30° 31' 14.17"	E 27° 23' 33.09"
S 30° 31' 35.56"	E 27° 24' 06.88"
S 30° 30' 55.65"	E 27° 22' 46.58"
S 30° 30' 37.85"	E 27° 22' 19.06"
S 30° 30' 30.87"	E 27° 22' 18.04"



water & sanitation

Department:
Water and Sanitation
REPUBLIC OF SOUTH AFRICA

STERKSPRUIT BULK SANITATION SYSTEM – PHASE 2A – TECHNICAL FEASIBILITY

NOVEMBER 2014

Compiled for:



JOE GQABI DISTRICT
MUNICIPALITY

Compiled by:



PO BOX 43335
HEUWELSIG
9332
TEL: +27 (0) 51 451 1814

Contents

- 1 INTRODUCTION 3
 - 1.1 PHASE 2A: TECHNICAL FEASIBILITY STUDY3
 - 1.1.1 Project Background and Objectives3
- 2 DEMAND ANALYSIS 5
 - 2.1 Existing Sewer Demand Analysis5
 - 2.2 Future Demand Projections7
 - 2.2.1 Identify the demand drivers for the various consumers7
 - 2.2.2 Factors affecting population growth.....7
 - 2.2.3 Population size and growth13
 - 2.2.4 Future demand projections.....17
 - 2.3 WATER SUPPLY INFRASTRUCTURE18
 - 2.3.1 Water Treatment Works18
 - 2.3.2 Service Storage.....19
- 3 WATER CONSERVATION & WATER DEMAND MANAGEMENT 21
 - 3.1 Introduction21
 - 3.1.1 Project Background and Objectives21
 - 3.2 WC / WDM Options.....21
 - 3.2.1 Leakage Reduction and Wastage in Herschel / Sterkspruit Town Area 21
 - 3.2.2 Consumer Water Use Reduction.....22
 - 3.2.3 Re-use Options22
 - 3.2.4 Infrastructure and Management Options.....22
 - 3.2.5 Potential Impact of WC/WDM on Future Water Requirement Projections
25
 - 3.2.6 Water Conservation and Water Demand Management Strategy
(Recommendation of this Study).....25
 - 3.2.7 Summary of WC/WDM Strategy.....27
- 4 WATER QUALITY INVESTIGATION 28
 - 4.1 Water quality assessment.....28
 - 4.1.1 Raw-water quality.....28
 - 4.1.2 Problem Constituents28

4.2	Upstream Pollution and Possible Risks	28
4.2.1	Catchments Serving Kromspruit.....	28
4.2.2	Water Quality Monitoring and Management Plan	29
4.2.3	Recommendations	29
5	ANALYSIS OF EXISTING INFRASTRUCTURE	30
5.1	Optimization of Existing Infrastructure	31
5.2	Upgrading Existing Infrastructure.....	31
5.3	Reduction of Reticulation Losses and Insufficient Water Usage.....	32
5.4	Reduction of Storm water Infiltration (for Waste Water Treatment Works).....	32
5.5	Assessment on the Capacity of Existing Infrastructure	32
5.6	Assessment on the Performance of Existing Infrastructure	32
5.7	Assessment the Condition of Existing Infrastructure.....	32
6	IDENTIFY VARIOUS OPTIONS	33
6.1	Option A: Sedimentation	33
6.2	Option B: Biological Filtration.....	34
6.3	Option C: The Rotating Biological Contactor	34
6.4	Option D: The Activated Sludge System.....	35
6.5	Option E: Sand Filtration.....	36
6.6	Option F: Pond Systems	37
7	DEFINE DESIGN/PLANNING CRITERIA	38
7.1	Key Design Criteria	38
7.2	Short term plan	38
7.3	Long term plan.....	38
7.3.1	Phase 1: drainage zone one.....	38
7.3.2	Phase 2: Drainage zone two	39
7.3.3	Phase 3: Drainage zone three.....	39
7.4	Scope of Works.....	39
7.4.1	WasteWater Treatment Works	39
7.4.2	Sewer Lift Pump Stations	40
7.4.3	Bulk Sewer Line	40
7.4.4	Electricity supply.....	40
7.5	Design Philosophy and Criteria for New WWTW	40
7.5.1	Hydraulic Considerations	40

7.5.2	Process considerations	41
7.5.3	Liquid and Sludge Unit Phases	41
7.6	Civil Requirements.....	45
7.6.1	Topographical Survey	45
7.6.2	Geotechnical Investigation	45
7.6.3	Structural Considerations	45
7.6.4	Site Access.....	46
7.6.5	Electrical and Instrumentation Requirements	48
8	FEASIBILITY OF VARIOUS OPTIONS	50
8.1	Pond system	50
8.2	Activated Sludge System	50
9	OPTION ANALYSIS.....	50

Figure 1:	Area of Joe Gqabi.....	3
Figure 2:	Sterkspruit Location.....	4
Figure 3:	Waste Water Treatment Works (Joe Gqabi District Municipality, 2010-11)	6
Figure 4:	Migration within and to the Greater Sterkspruit	9
Figure 5:	Age and sex of the Sterkspruit and surrounding areas population	12
Figure 6:	Average household size	13
Figure 7:	Annual population & household growth rates 2001-2011	15
Figure 8:	Greater Sterkspruit population estimate 2011 to 2035	16
Figure 9:	Water Distribution of Sterkspruit Urban Edge.....	19
Figure 10:	Schematic of Water Supply	20
Figure 11:	Oxidation Ponds	30
Figure 12:	Oxidation pond full to capacity.....	30
Figure 13:	Overgrow in oxidation pond.....	30
Figure 14:	AC sewer pipe repair with smaller PVC.....	31
Figure 15:	Gabions collapsed at river bank	31

Figure 16: B1 - Sterkspruit SDF..... 53
Figure 17: B2 - Population and households of Sterkspruit and surrounding areas (Census 2011) 54
Figure 18: B3 - Structure count (Eskom 2010) count..... 55

LIST OF ACRONYMS

BEE	Black Economic Empowerment
BOTT	Built-operate-train-and-transfer
CIP	Consolidated Infrastructure Programme
CoGTA	Cooperative Governance and Traditional Affairs
CMA	Catchment Management Agency
CMS	Catchment Management Strategy
DoRA	Division of Revenue Bill
DWS	Department of Water and Sanitation
EIA	Environmental Impact Assessment
EPWP	Expanded Public Works Programme
GDP	Gross Domestic Product
HDI	Historically Disadvantaged Individuals
IDP	Integrated Development Plans
ILI	Infrastructure Leakage Index
IRS	Implementation Ready Study
IRP	Integrated Resource Planning
IWA	International Water Association
IWRP	Integrated Water Resource Planning
IWRM	Integrated Water Resource Management
KPI	Key Performance Indicators
kℓ	Kilolitre = cubic meter = m ³ = 1 000 litre
LA	Local Authority
l/c/d	Litre per capita per day
m	Meter (10 meter water pressure = 1 bar)
Mℓ	Megalitre = 1 000kℓ = 1 000m ³
Mm ³ /a	Million cubic metres per annum
MNF	Minimum Night Flow
MoA	Memorandum of Agreement
MIS	Management Information System
NRW	Non-Revenue Water
NT	National Treasury

NWA	National Water Act
NWRS	National Water Resource Strategy
O&M	Operation and Maintenance
PMC	Project Management Committee
PRV	Pressure Reducing Valve
PSP	Professional Service Provider
PRV	Pressure Reducing Valve
PPP	Private Public Partnerships
RBIG	Regional Bulk Infrastructure Grant
RO	Regional Office
Reconciliation Strategy	Reconciliation Strategies for Sterkspruit Town, in Joe Gqabi District Local Municipality in lower Orange WMA. Final may 2011
SABS	South African Bureau of Standards
SC	Steering Committee
Section 78	Section 78(1) Assessment on Water and Sanitation Services (Draft) 12 July 2011
SMME	Small, Medium and Micro Enterprise
UAW	Un-accounted-for Water
WC	Water Conservation
WDM	Water Demand Management
WfGD	Water for Growth and Development
WRC	Water Research Commission of South Africa
WRM	Water Resource Management
WSA	Water Services Authorities
WSDP	Water Services Development Plans
WSI	Water Services Institutions
WSRF	Water Services Reference Framework
WTW	Water Treatment Works
WWTW	Waste Water Treatment Works

1 INTRODUCTION

1.1 PHASE 2A: TECHNICAL FEASIBILITY STUDY

The purpose of this phase is to carry out a demand analysis, quantify the need, identify the options and carry out an options analysis to determine the most viable option. At the end of this phase, all key stakeholders should agree to the proposed infrastructure option.

Step 2: The provincial planning forum together with DWS will review the technical feasibility studies and request changes, if required. Technical feasibility studies should also be aligned and reviewed by water resource planning and water services officials of DWS.



Figure 1: Area of Joe Gqabi

1.1.1 PROJECT BACKGROUND AND OBJECTIVES

Sterkspruit urban edge falls under the jurisdiction of the Joe Gqabi District Municipality (JGDM), which is located in the eastern part of the Eastern Cape Province. Sterkspruit urban edge is situated approximately 48km north-east of Lady Grey and 50 km south-east from Zastron. See **Figure 2** for a location of Sterkspruit.



Figure 2: Sterkspruit Location

The Sterkspruit area is within the Senqu Local Municipality within the Joe Gqabi District Municipality

2 DEMAND ANALYSIS

This technical feasibility phase will analyse the current demand and will formulate a projection of the future demands based on the circumstances described under Phase 1 “Scoping Report” of the previous report to this IRS and attached as **Appendix A**.

The methodology to execute this exercise will be a theoretical wastewater balance based on the data and assumptions obtained from previous studies compiled for this specific area, as well as information from current operations based within the municipal area pertaining to the service delivery of wastewater infrastructure. Other information, such as the All Town Reconciliation Strategy and WCWDM studies, will be utilized to predict future growth and to compile this report. A baseline survey will be conducted in order to verify the above mentioned information. This survey will also be used for community awareness and to identify skills within the area.

Sanitation refers to the principles and practices relating to the collection, removal or disposal of human excreta, household wastewater and refuse as they impact upon people and their environment. Good sanitation includes appropriate health and hygiene awareness and behaviour as well as acceptable, affordable and sustainable sanitation services. There is no doubt that sanitation is affected by and affects water resource availability, and therefore it needs to be incorporated when developing water reconciliation strategies.

2.1 EXISTING SEWER DEMAND ANALYSIS

It is estimated that a total of 113 households in Sterkspruit are serviced with a full waterborne sewerage system. Government institutions such as the prison, municipal offices, police station and a few businesses in the CBD area are also connected to the current sewer reticulation system.

The Sterkspruit Hospital has its own sewerage plant which is not functional and it is now connected to the municipal sewerage reticulation system. This also has a significant impact on the loading of the already overcapacity oxidation ponds.

Other areas such as Esilindini, Tapoleng and Mokhesi also form part of the study area and currently these areas do not have access to formal sewer systems, instead using buckets and/or dry systems. Some of the residents, however, constructed their own flush systems that require de-sludging on regular basis by means of a municipal suction tanker. As these even were not part of the original planning and development of the oxidation ponds, the additional loading causes overloading of the oxidation ponds.

The diagram below reflects the basic layout of the current infrastructure for the Sterkspruit sewer infrastructure.

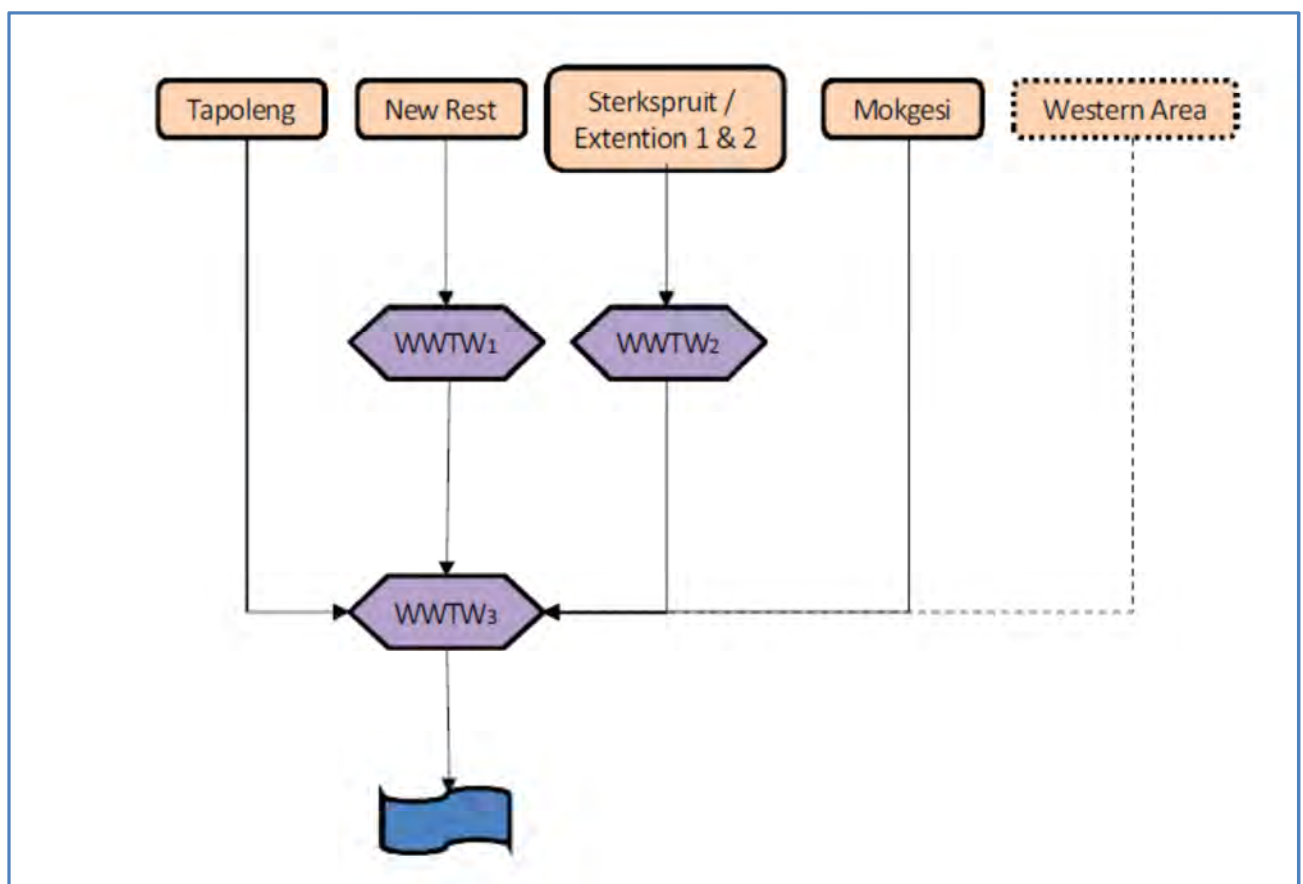

Figure 3: Waste Water Treatment Works (Joe Gqabi District Municipality, 2010-11)

As mentioned previously, Sterkspruit is the only area that has access to a sewer reticulation network, and the rest of the study area is served by tanker if and when required. Therefore, no existing sewage flow figures for the Sterkspruit study area are available.

Table 1: Waste Water Infrastructure Details (Joe Gqabi District Municipality, 2010-11)

Name	Description of WWTW
<i>WWTW 1:</i>	<i>Hospital – Activated Sludge Treatment</i>
Capacity	? Mℓ/d
Technology	Oxidation Ponds - Effluent return to River
<i>WWTW 2:</i>	<i>Prison Treatment Facility</i>
Capacity	? Mℓ/d
Technology	Oxidation Ponds - Effluent return to River
<i>WWTW 3:</i>	<i>High School Treatment Facility</i>
Capacity	0.5 Mℓ/d ¹
Technology	Oxidation Ponds - Effluent return to River

2.2 FUTURE DEMAND PROJECTIONS

2.2.1 IDENTIFY THE DEMAND DRIVERS FOR THE VARIOUS CONSUMERS

The possible activities driving the wastewater demand at the Sterkspruit area can be summarized as follows:

- Influx of people from the surrounding farms to the Sterkspruit area;
- Seasonal workers returning from work from other provinces;
- Growth from housing scheme developments by COGHSTA;
- The main driver on the wastewater demand lies in the increasing need of higher water and sanitation levels of services.

2.2.2 FACTORS AFFECTING POPULATION GROWTH

Population growth is determined by migration and natural growth, which is a function of fertility and mortality.

2.2.2.1 MIGRATION

Migration, together with fertility and mortality, is an aspect of population change. The people of the Eastern Cape are relatively immobile and tend to stay in the same place for their lifetime more frequently than the average South African. In 2011, 89% of Senqu's

¹ Green drop (2012) page 131

population had been there at least since 2001 or were born later and had not moved, which implies that its population is similarly mobile to the Eastern Cape (88%) overall, yet less mobile than the average South African (81%).²

The table below shows the extent of in-migration into Greater Sterkspruit since 2001; out-migration information is unavailable. Overall, 2 826 people moved into Greater Sterkspruit since 2001 or were born after 2001 and had moved there. Mokhesi (1 271) was the main recipient of this in-migration, followed by Tapoleng (946). Sterkspruit town received the fewest (137). However, the proportions of population that moved into the four areas of Greater Sterkspruit are similar ranging from 11% in Esilindini to 18% into Mokhesi. Senqu LM experienced a population movement of 11%, similar to JGDM (10%) and the Eastern Cape (12%).

Table 2: 2011 Population living in the current location since October 2001³

Migration	Number			%	
	Lived in same place since 2001/born after	Moved since 2001/born after & moved	Total	Lived in same place since 2001/born after	Moved since 2001/born after & moved
Esilindini	4 029	473	4 502	89%	11%
Mokhesi	5 713	1 271	6 984	82%	18%
Sterkspruit	804	137	941	85%	15%
Tapoleng	6 086	946	7 032	87%	13%
Total	16 631	2 826	19 457	85%	15%

² StatsSA, Census 2011.

³ StatsSA. Census 2011, Interactive data in Super Cross. Excludes Unspecified.

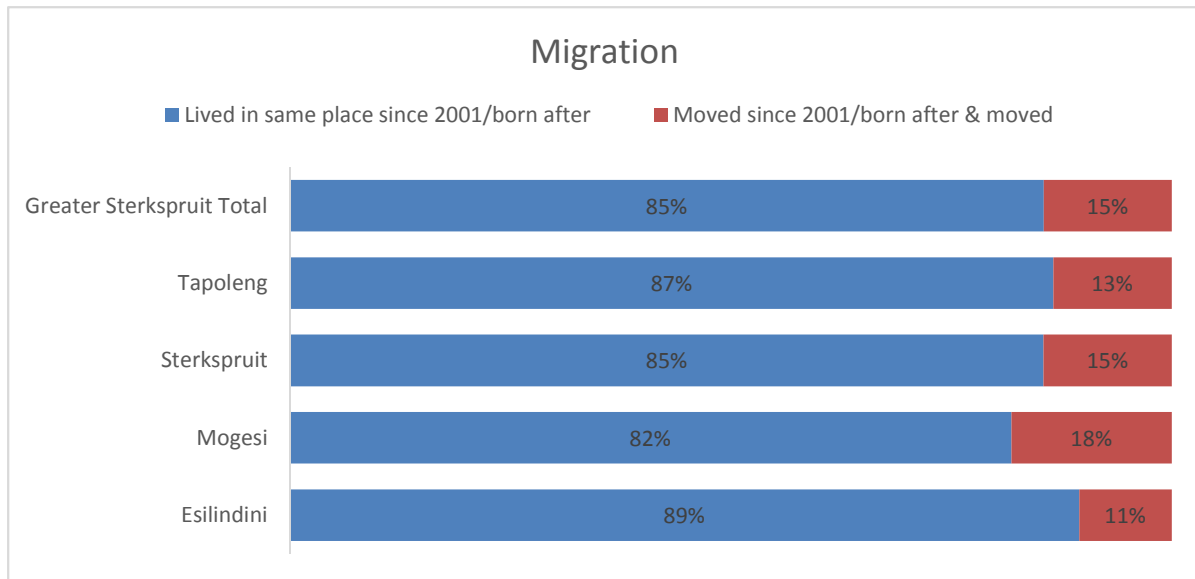

Figure 4: Migration within and to the Greater Sterkspruit⁴

Overall, a decline of immigration into the province is predicted. The 2011 Census indicated a net out-migration of 436 466 persons from the Eastern Cape and an in-migration of 158 205 resulting in a net migration of -278 261.⁴ Senqu Municipality, with its few strong pull-factors may not be able to attract immigrants from other parts of the Eastern Cape and beyond, although its proximity to Lesotho may be appealing.

Nevertheless, rural to urban migration remains prevalent.⁵ Rural migrants choose to relocate to small towns such as Sterkspruit and peri-urban areas closer to their rural areas of origin. This is because of the cost of migration, lower cost of living in smaller towns and the better access to government social services and transportation. Living closer to areas of origin enables retention of family links providing support in the event of illness or unemployment.⁶ Many migrants relocate to places where they have social networks, access to tenure or where a supply of housing is available. Although migrants are primarily attracted by employment opportunities, smaller towns and settlements offering the promise of access to housing and services, even with relatively weak economies making employment unlikely, are attractive.⁷

⁴ StatsSA. Census 2011, Statistical Release P0301.4.

⁵ Roux. N (2009) Migration and urbanization: Towards A 10-Year Review of the Population Policy Implementation in South Africa (1998-2008). Department of Social Development. [Online]. Available: <http://stepsa.org/resources/shared-documents/migration-and-urbanisation--dept-of-social> [cited 9 August 2013]. P ii.

⁶ Ibid. P iii, 14.

⁷ Ibid. P ii.

In 2001, 86% of Senqu households were rural in nature i.e. rural villages and farm households. By 2011, it reduced to 84%.⁸ This rural dynamic occurs because of migration into the urban areas of Senqu. The majority of the Senqu urban areas are situated around the town of Sterkspruit, and people are moving to live in villages towards the urban centre of Sterkspruit. The concept of a rural countryside with scattered homesteads is disappearing. An out migration of people from both the rural areas and urban areas of JGDM to other districts is also a feature. Nevertheless, an inward migration from Lesotho to Mt Fletcher and Sterkspruit is also experienced.⁹

The Senqu population decreased between 2001 and 2011, which can be attributed to out migration as people move to seek jobs and schooling and increasing urbanisation which is linked to decreased family sizes and women starting families later.¹⁰

However, household numbers in Senqu and Sterkspruit increased mainly due to the effect of the RDP housing programme. Increasing urbanisation and densification of Sterkspruit and surrounding settlements is further foreseen because the SDF makes spatial proposals for the area which includes the following:¹¹

- formalising settlements abutting Sterkspruit town and densification and infill of the surrounding settlements
- expansion of the higher order services business district to the south and to the east
- commonage and vacant land around the town needs to be reserved for service orientated land-use
- the construction of a southern ring-road and the upgrading of key linkage and access roads

According to the Senqu IDP, the spatial development framework highlights the roles played by settlements in the area and identifies key spatial development priorities for Sterkspruit as follows:¹²

⁸ StatsSA, Census 2011 and 2001. It is unclear whether the same definition of rural and urban was used in 2001 and 2011.

⁹ http://www.senqumunicipality.co.za/Downloads/Doc_306.pdf

¹⁰ <http://www.senqu.gov.za/AboutUs.html>

¹¹ UKHAHLAMBA DISTRICT SPATIAL DEVELOPMENT FRAMEWORK: Review 2009.

¹² Senqu IPD 2013/14. P 30.

- Key role as a high order service centre
- The need for land management and administration
- Linkages between the town and the surrounding settlements

It is also noted in the IDP that the rural settlement nodes listed below require strengthened linkages to Sterkspruit, and their accessibility to surrounding settlements must be enhanced to provide efficient localities for the provision of higher order facilities in these rural areas: ¹³

- N dofela
- Qoboshane/Telle-B
- Hillside-E
- Herschel
- Tourism potential in Senqu
- Holo Hlahatsi Dam
- Tourism nodes – Rhodes, Tiffindell, Barky East and Lady Grey

During the next five years, the district will focus on economic development programmes with the support and cooperation of strategic partners to revitalise small towns of which Sterkspruit (vision 2016), Ugie, Maclear and Mt Fletcher are listed. ¹⁴

These aspects will contribute to the continued in migration to Sterkspruit and the surrounding settlements.

2.2.2.2 NATURAL POPULATION GROWTH

Besides migration, population growth is determined by natural growth, which is a function of fertility and mortality.

The population pyramid of Sterkspruit and the surrounding settlements shows that the fertility rate has not decreased significantly because the youngest age group of 0 to 4 year olds is the broadest age category, although between the age categories of 15 to 24 the female population bulges and the males between age categories 10 to 24 years. The reason for this is not evident. Typically females have a longer life expectancy than males which can be seen at the top of the pyramid. The pyramid is fairly symmetrical i.e.

¹³ Senqu IPD 2013/14. P 30.

¹⁴ Senqu IPD 2013/14. P 38.

balanced between males and females. The sex ratio is 0.88 i.e. 0.88 males to 1 female, the same as that of Senqu LM but lower than the South Africa average of 95. This may indicate a migrant male population.

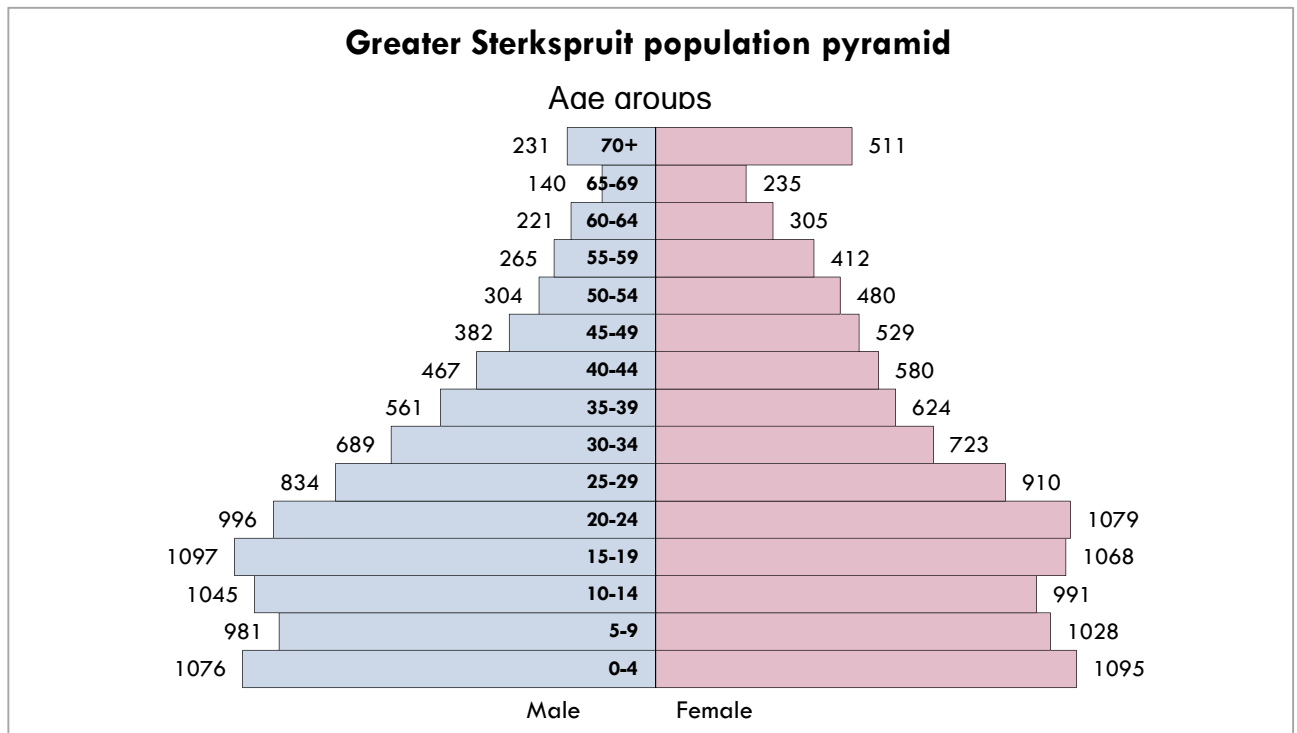

Figure 5: Age and sex of the Sterkspruit and surrounding areas population

According to the 2013/14 IDP, the levels of migration from Joe Gqabi are higher than the provincial average. At least 18% of JGDM household's reports of at least one migrant household member compared to 15.2% of provincial households. Approximately 7% of the JGDM population migrates from their households, while the provincial migration rate is 5.6%.

It is estimated that natural growth will continue to play a dominant role in population increase in the Eastern Cape in the near future because:

- Fertility rates will remain higher than the replacement rate of 2.2, decreasing from 3.40 in 2001 to 2.75 at end 2016.¹⁵ A UN report, states that the South African fertility rate will reduce from a current 2.40 to 2.18 by 2025.¹⁶

¹⁵Statistics South Africa. Mid-year population estimates 2013. P0302. [Online]. Available: <http://www.statssa.gov.za/publications/P0302/P03022013.pdf> [cited 11 August 2013] P 9.

¹⁶ United Nations, Department of Economic and Social Affairs, Population Division (2013). World Population Prospects: The 2012 Revision, Highlights and Advance Tables. Working Paper No. ESA/P/WP.228. [Online]. Available: http://esa.un.org/unpd/wpp/Documentation/pdf/WPP2012_HIGHLIGHTS.pdf [cited 11 August 2013] P 77.

- Life expectancy at birth of Eastern Cape males will increase to 53.7 years and females to 59.3 years in 2016.¹⁷ South African life expectancy will increase from current 57.1 years to 59.0 years in 2025, with decreasing infant and child mortality contributing to this.¹⁸

2.2.3 POPULATION SIZE AND GROWTH

2.2.3.1 POPULATION IN 2011

The 2011 Census recorded that there were 19 859 persons in Sterkspruit and surrounding settlements and almost 6 000 households resided there. The average household size was 3.43.

Table 3: Households, population and average household size in 2011¹⁹

	Households	Persons	Average household size
Esilindini	1 293	4 504	3.48
Mokhesi	1 956	6 985	3.57
Sterkspruit	386	1 274	3.30
Tapoleng	2 150	7 096	3.30
Total	5 785	19 859	3.43

The average household size for the Greater Sterkspruit area i.e. town and surrounding

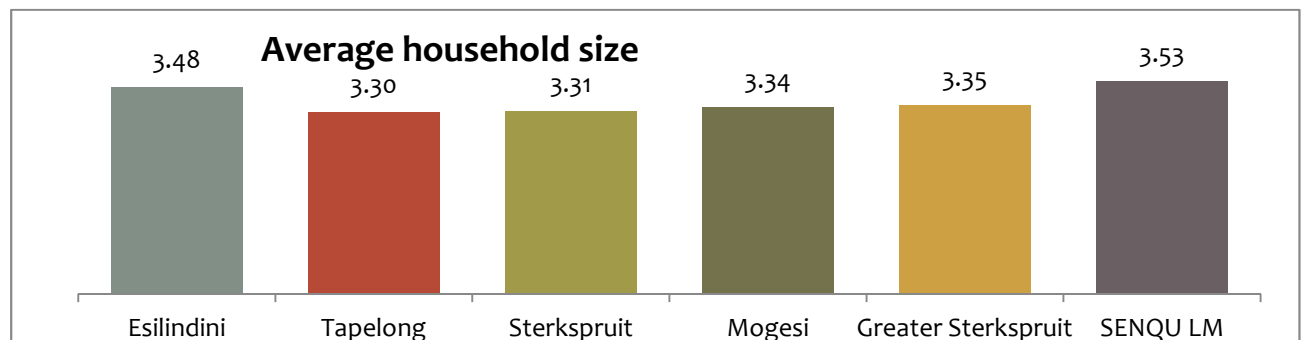

Figure 6: Average household size

¹⁷Statistics South Africa. Mid-year population estimates 2013. P0302. [Online]. Available:

<http://www.statssa.gov.za/publications/P0302/P03022013.pdf> [cited 11 August 2013]

¹⁸ United Nations, Department of Economic and Social Affairs, Population Division (2013). World Population Prospects:

The 2012 Revision, Highlights and Advance Tables. Working Paper No. ESA/P/WP.228. [Online]. Available:

http://esa.un.org/unpd/wpp/Documentation/pdf/WPP2012_HIGHLIGHTS.pdf [cited 11 August 2013] P 77.

¹⁹ Data source: StatsSA Census 2011.

area of Esilindini, Tapoleng and Mokhesi, and Senqu LM is shown in the adjacent figure. It illustrates that the household size of Greater Sterkspruit was 3.35, slightly lower than the average for the Senqu LM in 2011. Esilindini had a slightly higher average household size (3.48) while Tapeleng displayed the lowest (3.30).

Household size distribution shows that almost a third of households consisted of one person only (32%), while 6% of households consisted of seven or more persons.

Table 4: Household size distributions 2011²⁰

Household size	Total HH	%
1	1 847	32%
2	967	17%
3	891	15%
4	757	13%
5	515	9%
6	352	6%
7	189	3%
8	115	2%
9	66	1%
10+	86	1%
Total	5 785	100%

To validate the data from StatsSA, data from Eskom was consulted. Estimates from the Eskom spot count²¹ suggest that the population was 19 625 in 2010. This is based on Eskom's 2010 structure counts, to which the average household sizes are applied. It corresponds with the 2011 Census data.

To further verify the 2011 Census data, the baseline study results for Esilindini were consulted.²² This indicated an average household size of 3.81 and 1 202 occupied dwellings. The result is a population estimate of 4 585 for Esilindini, which corresponds to that of the 2011 Census.

²⁰ Data source: StatsSA Census 2011.

²¹ Data sources: Eskom Spot Data, 2010

²² A baseline study is being undertaken in Sterkspruit and surrounding settlements of which the data for Esilindini has been captured.

2.2.3.2 HISTORICAL POPULATION TRENDS AND FUTURE GROWTH EXPECTATIONS

Historical trends show that the population of the Sterkspruit town and surrounding area increased by approximately 2.64% p.a. between 2001 and 2011.²³ Households increased by an average of 3.4% during this same period. However, the population of Senqu decreased by -0.12% p.a. and its households increased by 1.16%. Sterkspruit and surrounding settlements are possibly still in a growth phase although this is expected to decline over the next 20 years.

It is expected that rural to urban migration will slow down, and natural growth will become the dominant growth factor due to the relatively large number of women in their reproductive ages of 15-44 years although fertility rates will continue to decline, and from increasing life expectancy and declining mortality rates.

Nevertheless, considering the past trends, Sterkspruit's relative attraction as a place to migrate to given its economy, relatively high fertility rate and increasing life expectancy rate results in the predominant growth to be natural

increases, supplemented with immigration into the area. The Reconciliation Strategy predicted negative annual growth rates from 2008 to 2030 of -0.14% in a high scenario and of -0.57% in a low scenario for the Herschel/Sterkspruit town areas.²⁴ However, this area is significantly larger than the study area, and a decline in the study area population is not foreseen.

In this study, low growth rates of 1.70% p.a. are applied in the initial period of 2011 declining to 0.6% by the end of 2035. A high growth scenario applies a growth rate of 2.45% in the initial period 2011 to 2015 declining to 1.5% in the last period 2030 to 2035. Between 2001 and 2011 a population growth rate of 2.64% p.a. was attained in the study

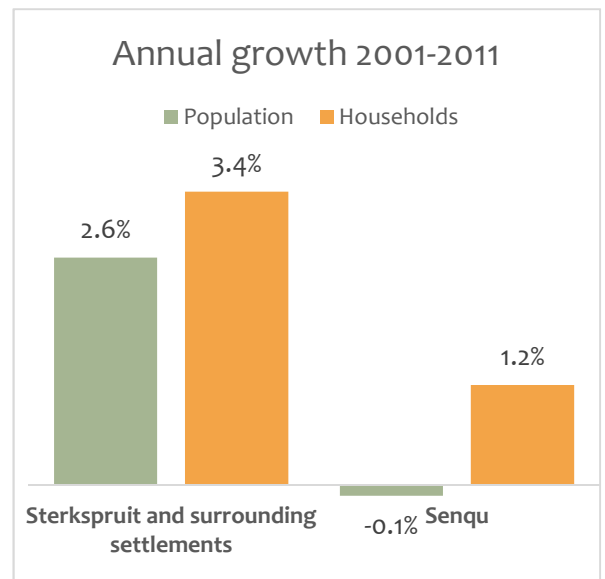

Figure 7: Annual population & household growth rates 2001-2011

²³ Census 2001 and 2011. EA were matches as closely as possible.

²⁴ DWA (2009) Reconciliation Strategy for Herschel/Sterkspruit town area, May 2011. P 13.

area. The population of Sterkspruit and the surrounding settlements is estimated to reach between 25 286 and 31 642 in 2035.

Table 5: Sterkspruit and surrounding areas population estimates from 2011 to 2035

Population of Sterkspruit and surrounding settlements	2011	2015	2020	2025	2030	2035
Population low	19 859	21 244	22 661	23 700	24 541	25 286
Population high	19 859	21 878	24 452	26 997	29 372	31 642
Growth p.a. low	2.64%	1.70%	1.30%	0.90%	0.70%	0.60%
Growth p.a. high	2.64%	2.45%	2.25%	2.00%	1.70%	1.50%

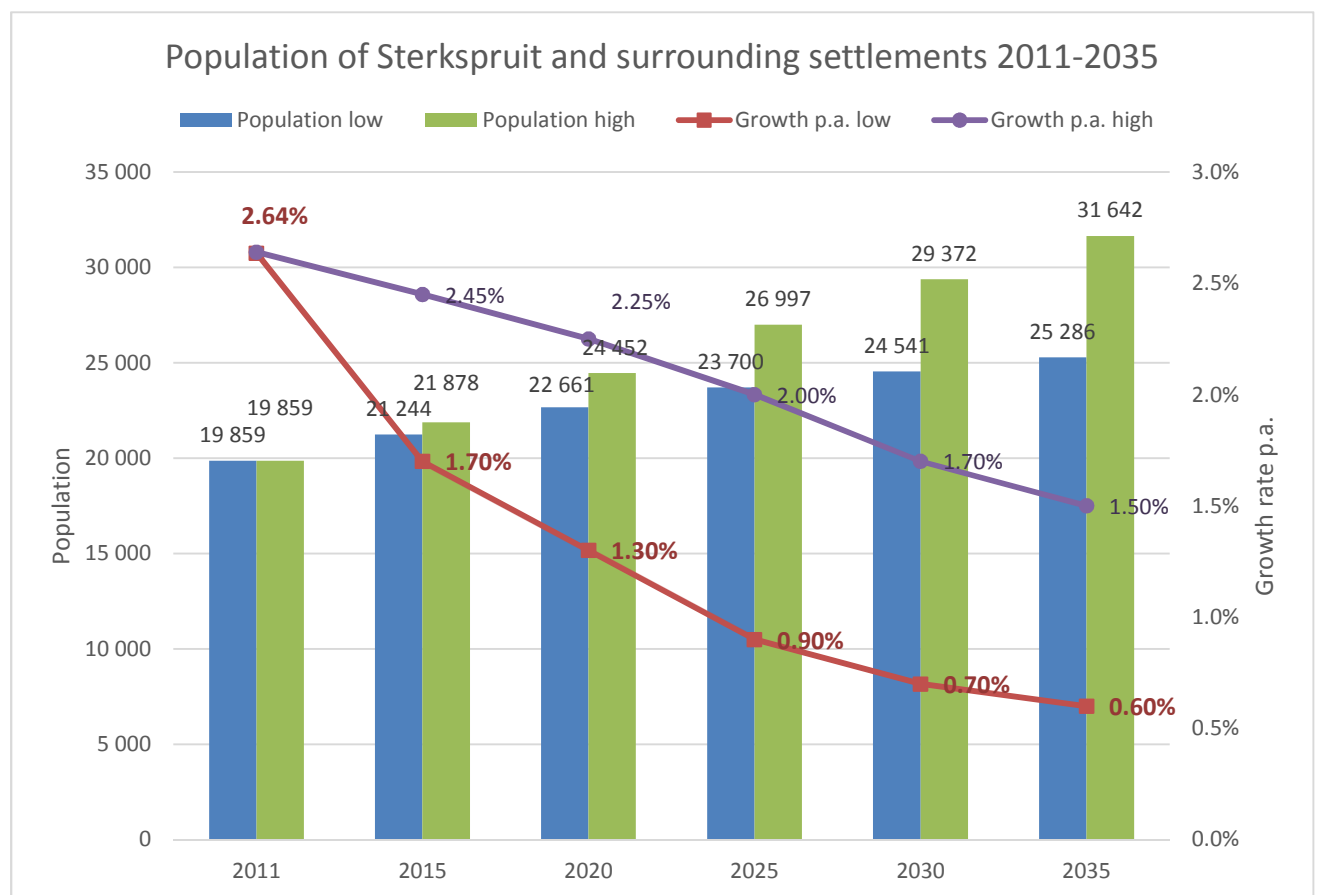

Figure 8: Greater Sterkspruit population estimate 2011 to 2035

Table 6: Key Statistics of Senqu

Key Statistics: SENQU ²⁵	2011	2001
Total population	134 150	135 734
Young (0-14)	34%	38%
Working Age (15-64)	58%	58%
Elderly (65+)	8%	8%
Dependency ratio	71.4	83.5
Sex ratio	88.0	88.5
Growth rate p.a.	-0.12%	0.67%
Population density in person per km ²	18	
Unemployment rate	35.5%	54.5%
Youth unemployment rate	43.6%	63.1%
No schooling aged 20+	14.5%	26.6%
Higher education aged 20+	5.4%	5.0%
Matric aged 20+	13.2%	8.9%
Number of households	38 046	33 904
Number of Agricultural households	17 222	
Average household size	3.5	3.9
Female headed households	50.5%	52.1%
Formal dwellings	70.2%	70.9%
Housing owned/paying off	68.5%	68.2%
Flush toilet connected to sewerage	11.9%	3.7%
Weekly refuse removal	12.5%	10.8%
Piped water inside dwelling	8.7%	4.1%
Electricity for lighting	81.1%	62.0%

See maps of Sterkspruit SDF, Population and households in Sterkspruit and surrounding areas (Census 2011) and Structure count (Eskom 2010) in **Appendix B**.

2.2.4 FUTURE DEMAND PROJECTIONS

In order to estimate the flow for the area, average daily flow figures were taken from past experiences in other similar towns, as well as the “Guidelines for the Provision of Engineering Services in Residential Townships”. Assumptions made are detailed below.

²⁵ Statistics South Africa.

Table 7: Design Criteria

Income Group	Lower	Middle	Higher	Population
Litre per unit per day	560	750	1000	700
Persons per unit	7	6	5	3.5
Litres per capita per day	80	125	200	200

To calculate the design flow, it was assumed that an infiltration rate of 15% should be added during rainstorms. The normal peak factors derived from the Harmon Formulae is applicable and the average dry weather flows were calculated as shown in **Table 8**.

Table 8: Estimated Sewage Flow: Average Dry Weather Flow (ADWF) in kl/day

Town	kl/d (200 l/c/d clean water)						
	Peak factor	2011	2015	2020	2025	2030	2035
Sterkspruit	2.6 -2.25	228.42	241.83	270.85	286.24	298.91	315.97
Esilindini	2-1.87	588.58	644.07	710.64	769.61	825.98	878.05
Tapoleng	1.87-1.8	915.08	1 001.21	1 121.44	1 220.36	1 315.62	1 405.23
Mokhesi	1.87-1.8	832.51	911.04	1 020.26	1 110.22	1 197.15	1 278.63
TOTAL		2 564.59	2 798.15	3 123.19	3 386.43	3 637.66	3 877.88

As indicated above the theoretical current flow for the Average Dry Weather Flow (ADWF) will be 2,5 kl per day during 2014 and 3,8 kl per day during 2035.

2.3 WATER SUPPLY INFRASTRUCTURE

2.3.1 WATER TREATMENT WORKS

A water purification plant is situated between Sterkspruit, Region 2, Region 3 and the Holohlatsi dam. A second plant is situated between Region 1 and the Holohlatsi dam. The Department of Water and Sanitation is the current owner and the operator is Amatola Water.

The combined capacity of the existing plants is indicated as 6.845 Ml/day (6.4 Ml/day according to Blue drop 2012). The water works are running at an operational capacity (% to design) of 117.19 % and obtain a score of 95.9 % according to Blue drop 2012.

Bigen Africa was appointed by Joe Gqabi District Municipality on the 14th July 2010 to prepare a Water, Sanitation and Electrical Master Plan for the rural areas of the Senqu Local Municipality. The Upgrading of the Sterkspruit Water Treatment Works and Bulk Supply lines: Phase II was a technical report drafted in November 2010 by Bigen Africa. This report states that under phase I the water treatment works is upgraded to a 12 M³/day plant.

2.3.2 SERVICE STORAGE

Purified water from the water purification plants is transferred to seven reservoirs with a combined capacity of 9.05 MI. A 25 kl reservoir obtains water from a borehole and supplies Herschel. The Sterkspruit reservoirs are in fair condition and will not require replacement but will need to be upgraded within the next 10 years. The Herschel reservoir is in a poor condition and will require an upgrade within the next 10 years.

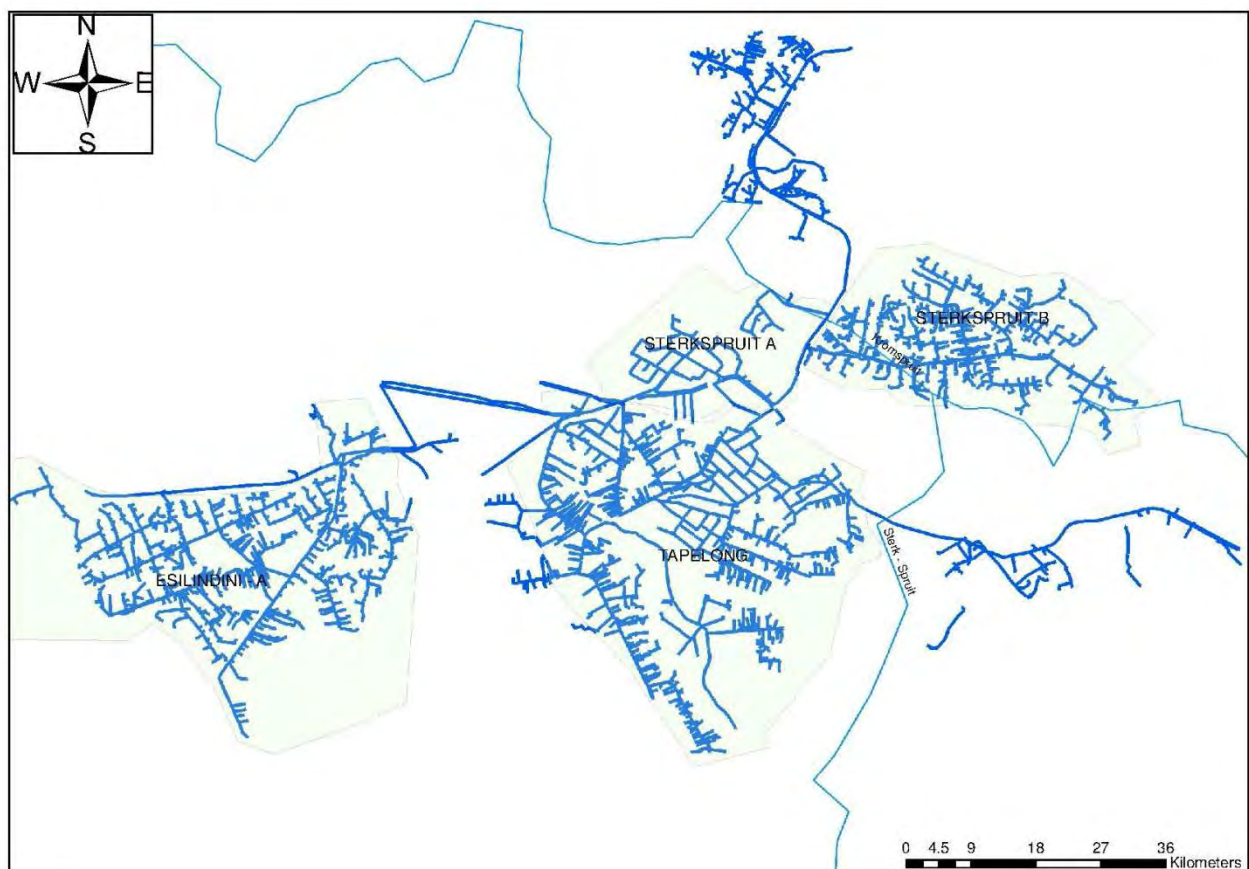

Figure 9: Water Distribution of Sterkspruit Urban Edge

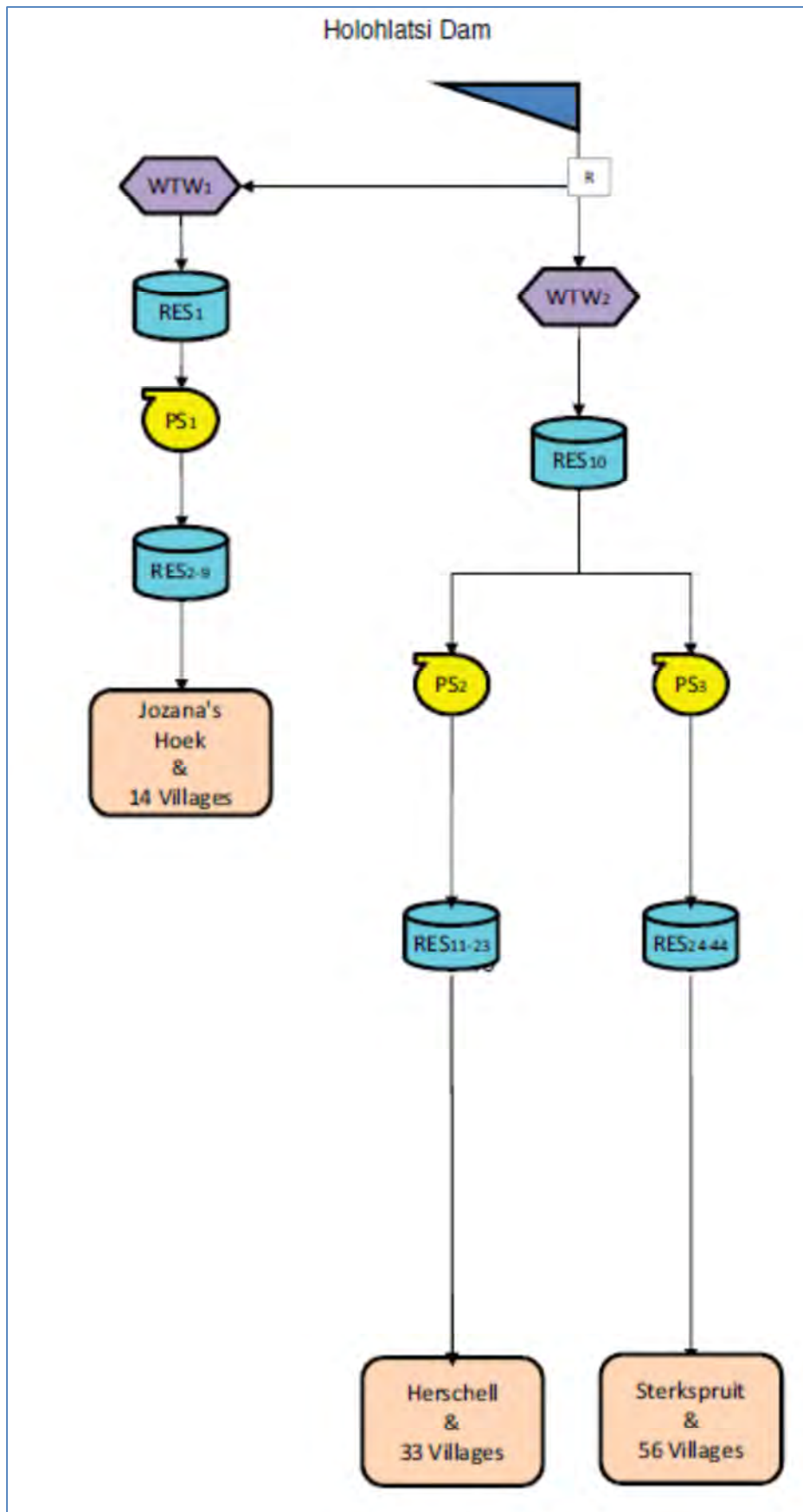

Figure 10: Schematic of Water Supply

3 WATER CONSERVATION & WATER DEMAND MANAGEMENT

3.1 INTRODUCTION

3.1.1 PROJECT BACKGROUND AND OBJECTIVES

The Joe Gqabi District Municipality is currently running a water conservation and water demand management programme in association with Bigen Africa (Pty) Ltd. The implementation of a waterborne sewage system will impact on the water use of the area. The WC/WDM programme will need to be adapted to include sewage systems and include steps taken to effect water conservation.

The Joe Gqabi District Municipality does not have a formal water conservation and demand management (WC/WDM) strategy. Repairs of leaks in urban areas are done by the municipal staff as they occur but there is a lack of a structured maintenance programme. Thus leaks are usually repaired once they occur rather than prevented. The response time to repair leaks is often slow, resulting in considerable water losses and disgruntled communities. The situation is worse in the rural areas than in urban areas. A structured maintenance and repair programme does not exist in most areas. There is no reporting system in place so often leaks are not attended to for days due to the fact that no official knows about them, or due to a shortage of staff. The failure of the community to report may be linked to a lack of ownership of the systems. The WC/WDM for Joe Gqabi District Municipality is to be commissioned and it will address and identify the gaps and a strategy. (WRP Consulting Engineers (Pty) Ltd in association with DMM and Sub-Consultants, May 2011)

3.2 WC / WDM OPTIONS

3.2.1 LEAKAGE REDUCTION AND WASTAGE IN HERSCHEL / STERKSPRUIT TOWN AREA

A preliminary analysis of the Herschel / Sterkspruit area, water supply system estimates that about no savings can be obtained by implementing WC/WDM. The main reason for this is firstly, limited information on the current system is available and as a result, certain inputs into the standard water balance model have been estimated. The current information already shows a low consumption per household per day when comparing the

bulk system input volume with the number of households. Secondly, some of the towns in the area operate on an intermittent supply, and any reduction of losses will merely result in an increased level of service to all consumers, which will therefore not reduce the water use. (WRP Consulting Engineers (Pty) Ltd in association with DMM and Sub-Consultants, May 2011)

3.2.2 CONSUMER WATER USE REDUCTION

There is potential for implementing consumer water use reduction through instruments such as tariff structures and consumer awareness and education. Consideration should be given to implement a properly designed increasing block tariff together with the water loss control measures. This is only efficient if billing and payment levels are high. (WRP Consulting Engineers (Pty) Ltd in association with DMM and Sub-Consultants, May 2011)

3.2.3 RE-USE OPTIONS

Sewage from the Sterkspruit town is treated by three treatment plants which consist of oxidation ponds. After treatment, it is returned to the river. No re-use takes place nor is it foreseen in the near future. (WRP Consulting Engineers (Pty) Ltd in association with DMM and Sub-Consultants, May 2011)

Re-use of effluent will be limited to irrigation of school sport fields.

3.2.4 INFRASTRUCTURE AND MANAGEMENT OPTIONS

Although the preliminary analysis WC/WDM estimated that no saving can be obtained by implementing WC/WDM. The potential for WC/WDM however needs to be investigated in more detail as there are apparently large volumes of losses within the system. Removing these losses might not lower the demand but will reduce the intermittent supply to some areas. (WRP Consulting Engineers (Pty) Ltd in association with DMM and Sub-Consultants, May 2011)

Table 9: Summary of WC/WDM Strategy for Sterkspruit Urban Edge

Item	Summary of Tasks	Estimated Costs (Rand)	Priority	Potential Water Saving
Water Audit	The municipality should create a software module to enable easy extraction of the billed consumption data for Sterkspruit urban edge and to use that data to prepare annual water balances. Update water balance annually.	Cost for software module to extract billing data per town will be included in WC/WDM plan.	1	None
Pressurised System	None	None	n/a	None
Consumer Metering	The meter for the municipal building should be read and included in the billing system. The municipality should continue to ensure that all connections are metered, meters remain in good working order and readings are obtained monthly.	None additional. Included in O&M	1	None
Effective and Informative Billing System	A separate exercise should be undertaken to re-assess the block tariffs for the Joe Gqabi District Municipality. Smaller intervals between block tariffs should be used and the rate per kℓ should increase as the consumption increase (typically 0-6kℓ, 7kℓ – 15kℓ, 16kℓ - 25kℓ etc.) The purpose thereof is to curb excessive consumption of individual consumers and to generate additional income for the municipality from consumers that use in excess of 25kℓ per month.	Undertaken by the Municipality	1	None
Complaints System	The municipality should ensure that consumers are familiar with the telephone numbers to lodge complaints/ report leaks – this can be linked to awareness campaign on water conservation.	Included elsewhere in strategy	2	None
Asset Register	No additional tasks	None	n/a	None
Asset Management: Capital Works	The condition of water infrastructure in Sterkspruit urban edge varies between fair and good and fortunately the leakage levels are low. The Joe Gqabi District Municipality should continue to monitor the condition of infrastructure. When the condition starts deteriorating budget should be allocated for the replacement of between 8% (National Treasury, 2011) of the water infrastructure annually	To be determined by the municipality	3	None
Asset Management: O&M	Even though the budget available for O&M in Sterkspruit urban edge seems relatively low the municipality have managed to keep the water losses under control. No recommendations.	None additional. To be determined by the municipality.	3	None

Item	Summary of Tasks	Estimated Costs (Rand)	Priority	Potential Water Saving
Active Leakage Control	Leakage levels are currently low/moderate. Active leak detection not currently required. The municipality should continue to repair leakages as soon as they are reported. Every five years the municipality can repeat the leak detect and repair exercise.	None	2	Estimate 0.5% of Input Volume = 350kℓ/a
Sectoring	No need for sectoring network. Every five years the minimum night flow can be logged and analysed to determine if there has been an increase in leakage.	R15 000 every few years for logging and analysing	2	None
Bulk Metering	All boreholes and reservoir outlets are currently metered.	Undertaken by municipality	2	None
Credit Control	Enforce credit control policy	Undertaken by Municipality	1	None
Pressure Management	No tasks	None	n/a	None
As-Build Drawings & Master Planning	No tasks	None	n/a	None
Regulation of water fittings	The new proposed bylaws should be accepted and promulgated and the regulation of water fittings should be enforced.	Undertaken by the Municipality	3	None
By-laws	The new proposed bylaws should be accepted and promulgated and the regulation of water fittings should be enforced.	Undertaken by the Municipality	3	None
Removal of illegal connections	According to the Joe Gqabi District Municipality there are no un-metered or un-authorized connections that they are aware of.	None	n/a	None
Community Awareness on WDM	The Joe Gqabi District Municipality may consider alerting consumers of possible leaks on their properties. For instance, if the consumption for a particular month is more than 20% higher than the average consumption of the previous months the consumer may be alerted of a possible leak on the property.	To be determined by the municipality.	3	Estimate 0.5% of Input Volume = 350kℓ/a
	The Joe Gqabi District Municipality can also consider adding helpful hints on effective water usage on the monthly bills.	R10 000/yr	2	None
Schools Education on WDM	Once a year a school education programme on water conservation should be undertaken. The municipality should assist the schools with the monitoring (water audit) of their water consumption.	R10 000/yr	2	None
Waste Effluent Re-use	No effluent.	None	n/a	None

Item	Summary of Tasks	Estimated Costs (Rand)	Priority	Potential Water Saving
Retrofit internal plumbing leaks	Retrofit tip-tray urinal at schools to operate with a push button. Also inspect all water use points at schools during this exercise and repair all leaks identified.	R15 000	1	± 2000kl/a
	On-going exercises to repair leakages at 12 properties using in excess of 50kl/month.	R20 000/exercise	1	± 2000kl/a

3.2.4.1 BULK WATER INFRASTRUCTURE

The bulk water supply infrastructure for the Sterkspruit urban edge is in place. See **Figure 9** for distribution of the pipelines as recorded in the Assets Register of Joe Gqabi District Municipality.

3.2.4.2 WATER TREATMENT CAPACITY

Bigen Africa was appointed by Joe Gqabi District Municipality on the 14th July 2010 to prepare a Water, Sanitation and Electrical Master Plan for the rural areas of the Senqu Local Municipality. The Upgrading of the Sterkspruit Water Treatment Works and Bulk Supply lines: Phase II was a technical report drafted in November 2010 by Bigen Africa. This report states that under phase I the water treatment works is upgraded to a 12 Ml/day plant.

3.2.4.3 BULK WATER METERS

No mention was made of bulk water metering in the abovementioned report.

3.2.5 POTENTIAL IMPACT OF WC/WDM ON FUTURE WATER REQUIREMENT PROJECTIONS

Based on the results from the water balance it can be concluded that water losses are low/moderate and consumers are generally using water efficiently. If the municipality and consumers continue to limit water losses and use water efficiently in the future it is not expected that WC/WDM will have a significant impact on projected water requirements.

3.2.6 WATER CONSERVATION AND WATER DEMAND MANAGEMENT STRATEGY (RECOMMENDATION OF THIS STUDY)

A basic scorecard (as shown in the table below) was used to assess the potential for WC/WDM efforts in Sterkspruit. This assessment was undertaken by the project team. The aim of the scorecard was to establish areas where the municipality has made good progress in relation to WC/WDM and where there is still room for improvement.

Table 10: Summary of WC/WDM Scorecard for Sterkspruit

Item No.	Description	Max Points	Score
1	Development of Standard Water Balance	5	5
2	Pressurised Supply to all consumers 100% of time	5	5
3	Consumer Metering System	5	5
4	Effective Billing System including Informative Billing	5	5
5	General Complaints System	5	5
6	Asset Register for Water Reticulation System	5	5
7	Asset Management - Capital Works	5	3
8	Asset Management - Operations and Maintenance	5	3
9	Active Leakage Control	5	3
10	Effective Sectorisation	5	5
11	Effective Bulk Meter Management	5	5
12	Credit Control Policy and Implementation	4	3
13	Pressure Management	4	4
14	As-Built Draw ings of Bulk and Reticulation Infrastructure	5	5
15	Regulation of Water Fittings	5	3
16	By-Law s that relate to Water Conservation	5	3
17	Removal of un-authorized connections	5	4
18	Community Aw areness and Education Programmes	5	2
19	Schools Aw areness and Education Programmes	5	2
20	Waste Effluent Re-use Investigation	3	3
21	Retrofit Internal Plumbing in Public Buildings & Indigent Properties	4	2
	Totals	100	80

It can be seen in the table above that there are 21 questions each of which carries a maximum of 3 to 5 points providing a possible maximum score of 100. If the Municipality has the specific item completely under control, it receives the maximum point and if it is neglecting the item completely it receives no point. There are various levels between the

maximum and minimum number of points assigned to the municipality for each item depending on the level of completeness or lack thereof.

It can also be seen that the scorecard suggests a total score of **80** out of a possible **100** suggesting that the Joe Gqabi District Municipality has made good progress in addressing water conservation and water demand management in Sterkspruit.

Based on the scorecard results a water demand management / water conservation strategy was developed. It has been mentioned that the water losses in Sterkspruit are currently low to moderate and in addition the consumers are generally using water efficiently. The water demand management / water conservation strategy recommended is therefore not aimed at reducing high leakage levels but rather to provide guidelines on where the municipality can improve further and also maintain the good management of the water reticulation system.

3.2.7 SUMMARY OF WC/WDM STRATEGY

It has been mentioned that the water losses in Sterkspruit are currently low/moderate and that consumers are generally using water efficiently. The water demand management / water conservation (WC/WDM) strategy recommended is therefore not aimed at reducing high leakage levels but rather to provide guidelines on where the municipality can improve further and also maintain the good management of the water reticulation system.

4 WATER QUALITY INVESTIGATION

4.1 WATER QUALITY ASSESSMENT

4.1.1 RAW-WATER QUALITY

Four sewage water samples were taken and analyzed in the laboratory. A detailed summary of the raw water quality is attached, and below is a summary of the average water quality in the distribution network.

Table 11: Average water quality in the distribution network

Parameter	Unit	Value
Turbidity	NTU	2
EC	mS/m	101
pH @ 25°C		7.7
Total Hardness	mg/l as CaCO ₃	414.6
Calcium	mg/l	71.1
Magnesium	mg/l	57.5
Chlorides	mg/l	84
Fluoride	mg/l	0.5
E.Coli	cfu/100 ml	2.2
Total Coliform Count	cfu/100 ml	13.6
Free chlorine	mg/l	0.6

4.1.2 PROBLEM CONSTITUENTS

From the parameters that were tested, no major concerns arise for health implications and problem constituents are mainly related to aesthetic concerns

4.2 UPSTREAM POLLUTION AND POSSIBLE RISKS

4.2.1 CATCHMENTS SERVING KROMSPRUIT

Potential pollution risks related to the Kromspruit near Sterkspruit will be associated with pollution of surface water during the rainy season due to a lack of proper sanitation in the Sterkspruit urban edge.

This surface water is used downstream of Sterkspruit to supply water to other towns in the Joe Gqabi District Municipality.

4.2.2 WATER QUALITY MONITORING AND MANAGEMENT PLAN

The Joe Gqabi District Municipality takes part in the Blue Drop certification programme and is adequate in its quality monitoring and management planning for Sterkspruit.

4.2.3 RECOMMENDATIONS

Latest information on the water supply system needs to be obtained and addressed in the follow-up reports.

5 ANALYSIS OF EXISTING INFRASTRUCTURE

It is estimated that a total of 113 households in Sterkspruit are serviced with a full waterborne sewerage system. Government institutions such as the prison, municipal offices, police station and a few businesses in the CBD area are also connected to the current sewer reticulation system.



Figure 11: Oxidation Ponds



Figure 13: Oxidation pond full to capacity

the banks of the river are eroded by flood waters, it has exposed the sewerage pipeline and caused it to break at critical places. Temporary

The existing oxidation ponds at the northern side of Sterkspruit alongside the Kromspruit are filled to capacity and effluent is overflowing into the river. The position of the oxidation ponds are also situated in an area where no further development can take place. See the aerial photo below indicating the locality.

See **Annexure C** for the larger layout and positioning of oxidation ponds between mountains area.

The existing bulk sewerage supply pipeline connecting Sterkspruit with the oxidation ponds is partially constructed on the banks of the Kromspruit. At some places where



Figure 12: Overgrow in oxidation pond



Figure 14: AC sewer pipe repair with smaller PVC

repaired with smaller uPVC pipes. This also has a negative hydraulic effect on the delivery system from Sterkspruit to the oxidation ponds.

repairs to the pipeline do not seem to be sufficient.

It is also clear that the older AC pipe was



Figure 15: Gabions collapsed at river bank

5.1 OPTIMIZATION OF EXISTING INFRASTRUCTURE

It will not be desirable to expand the current infrastructure in the form of oxidation ponds. The current pond system is situated within a natural drainage area on the banks of the Kromspruit, within a ravine that is enclosed by surrounding mountain topography. The area to expand to is also limited in size, and will not be sufficient for the demand of 4.5Mℓ/day. It is estimated that a total area of at least 10 ha will be required to accommodate the future demand if the oxidation ponds need to be expanded. It is also not recommended to develop oxidation ponds with a demand of more than 2 Mℓ/day.

5.2 UPGRADING EXISTING INFRASTRUCTURE

The existing infrastructure should not be upgraded for the same reasons as per paragraph 5.1 mentioned above.

5.3 REDUCTION OF RETICULATION LOSSES AND INSUFFICIENT WATER USAGE

Training programmes by the Joe Gqabi District Municipality will help to inform the residents on how to maintain and manage a waterborne sewage system in order to limit water usage.

5.4 REDUCTION OF STORM WATER INFILTRATION (FOR WASTE WATER TREATMENT WORKS)

Storm water in Sterkspruit may infiltrate the current sewer reticulation system. It is recommended that efficient manhole placing and sealing thereof be implemented with especially new reticulation systems.

The current oxidation pond system is also not secure against storm water inflows. The oxidation ponds are also more than 100% full to capacity which influences the water quality of the Kromspruit and later Orange River when spillages occur.

5.5 ASSESSMENT ON THE CAPACITY OF EXISTING INFRASTRUCTURE

The sewage emanating from the Sterkspruit area is treated at the Sterkspruit oxidation ponds (WWTW) which has a theoretical capacity of 513 kℓ/day.

As can be seen in paragraph 5.1 the theoretical future sewage outflow to a WWTW will be 4.5Mℓ/ day. It is also far more than the existing 0.5 Mℓ/ day, currently treated by the oxidation ponds. It is clear that the future demand supersedes the current capacity nine times over.

5.6 ASSESSMENT ON THE PERFORMANCE OF EXISTING INFRASTRUCTURE

The overall performance of the existing infrastructure can be rated as poor. The oxidation ponds are overflowing and need attention to be functional. The bulk sewer connector between Sterkspruit and the oxidation ponds needs attention as it is repaired with uneven piping and is a risk so close to the Kromspruit.

5.7 ASSESSMENT THE CONDITION OF EXISTING INFRASTRUCTURE

As discussed earlier in this report, the overall condition of the existing infrastructure for bulk wastewater supply in Sterkspruit can be classified as poor.

6 IDENTIFY VARIOUS OPTIONS

The design of a new sewage treatment works, or the extension to an existing works should be based on the following information:

- Volumetric assessment of the flow rate which will determine hydraulic aspects of the works; and
- Sewage strength according to various parameters which will determine the biological and chemical processes in the works.

If the existing works has to be extended and records of flow, sewage constituents and plant performance are available, the future trends could be based on that data. A careful study of the rate of flow, the fluctuation in sewage strength and the performance data of the various existing units in the plant will of considerable value.

In this case however, no reliable data on the existing or the proposed new works is available; therefore a water sample was taken and tested on the 16 September 2014.

Samples of the current effluent was taken and analysed. The following parameters were obtained to characterise the domestic sewage:

i.	pH value	7.53
ii.	Electrical conductivity	44.1 mS/m
iii.	Ammonia (NH ₃ as N)	15.77 mg/ ℓ
iv.	Chemical oxygen demand (COD)	612 mg/ ℓ
v.	Nitrate (NO ₃) /Nitrite (NO ₂) as N	<0.5 mg/ ℓ
vi.	Orthophosphate (PO ₄)	3.46 mg/ ℓ
vii.	Orthophosphate (PO ₄) as P	1.13 mg/ ℓ
viii.	Suspended Solids (SS)	208 mg/ ℓ

The following are different options that can be investigated for a possible solution to the growing increase in demand for wastewater treatment.

6.1 OPTION A: SEDIMENTATION

Sedimentation is the backbone of efficient sewage treatment practice. It is not confined to one method of treatment but is common to all and it is the least expensive method of separating suspended matter from liquid under the influence of gravity. In practice it

consists of reducing the velocity of the flowing liquid to allow suspended particles, having a certain specific gravity, to separate from the main body of the liquid and settle on the floor of the tank as a sludge which may then be removed. (WISA, 1988)

A sedimentation tank is defined as a tank in which sewage or treated effluent is retained long enough to bring about sedimentation of suspended matter but short enough to prevent anaerobic decomposition.

6.2 OPTION B: BIOLOGICAL FILTRATION

Biological filtration provides a reliable and simple unit process for sewage treatment. A biological filter comprises a bed of media, which is usually a granular material such as crushed stone, but may also be plastic material in various shapes, over which settled sewage is sprayed and through which it percolates. Slime, containing a large number of organisms, forms on the surface of the media. As the sewage flows over this slime a series of complex bio-chemical reactions takes place by which organic material is removed from the sewage. The effluent is directed to collector drains by slopes in the floor.

The organisms require oxygen which is obtained from the air circulating in the filter bed. Maximum ventilation should be provided to supply enough oxygen to the organisms.

The slime increases in thickness until eventually portions break away and are carried out of the bed in the effluent. This material is known as “humus” which has to separate from the effluent in a bio filter. (WISA, 1988)

6.3 OPTION C: THE ROTATING BIOLOGICAL CONTACTOR

The Rotating Biological Contactor (RBC) belongs to the family of aerobic biological attached-growth sewage treatment system. The RBC may also be referred to as a rotating disc unit, rotating disc process, rotating biological filter and rotating biological surface.

The RBC is in effect an oxygen mass transfer device and generally consists of a large number of circular discs spaced uniformly along the length of a shaft. The shaft is mounted across a tank above water level such that approximately 40% of the disc area is

submerged in the sewage to be treated. The discs are usually between 1 and 3.5 mm diameter and are manufactured of a material, or in a manner, which gives a large surface area to void ratio. The contactor is rotated at between 1 to 5 rpm.

A biomass film 1 to 4 mm thick develops on the discs. As the contactor rotates, a film of sewage attaches to the biofilm and is carried through the air resulting in aeration of biofilm and sewage. Shearing forces cause excess biomass to be stripped intermittently from the rotating discs. To produce a clear effluent the sloughed biomass is removed in a sedimentation tank, and the final effluent is chlorinated.

RBCs may be used to treat primary sewage effluent i.e. sewage which has been treated in a primary sedimentation tank and may also be used in conjunction with pond systems.

Extended power failures may cause drying of exposed sections of the discs resulting in an imbalance. On subsequent start-up this may cause excessive torque resulting in gear stripping.

RBCs are relatively capital intensive and are therefore more suited to steady sewage flow situations.

6.4 OPTION D: THE ACTIVATED SLUDGE SYSTEM

The activated sludge process effects oxidation of organic compounds similar to the biological filter but whereas sewage is poured through air in the latter, the activated sludge process necessitates that air is blown through the sewage which may be either raw or settled. In the biological filter, the micro-organisms are attached to the media as a relatively thin film, but in the activated sludge process these micro-organisms are in the "active" sludge.

The process comprises a reactor basin in which micro-organisms are suspended in the sewage, oxygen is introduced by mechanical means and bio-chemical reactions take place by which organic pollutants are removed from the sewage. The suspended active sludge is separated from the effluent in a clarifier and is returned to the reactor. The mass

of active sludge continually grows and sludge has to be wasted from the system to maintain the correct balance. (WISA, 1988)

The active sludge is a living microbial culture which develops in the process. This active sludge is not composed of sludge which is introduced with the sewage, but grows as a result of the organic “food” present in the effluent.

The activated sludge process may be used as a complete treatment stage when preceded only by an inlet works comprising of a bar screen and grit channels. It may also be used as the secondary stage of treatment following primary sedimentation.

6.5 OPTION E: SAND FILTRATION

Filtration through a porous media is a physical and chemical process capable of removing not only suspended and colloidal material from liquid, but also bacterial contaminants. The removal mechanisms include adsorption, flocculation, sedimentation and straining processes. Adsorption is a function of both physical characteristics such as filter media grain size, flock size, strength and adhesive properties and also electrochemical characteristics and the Van der Waal molecular cohesive forces between particles.

Sand filtration with or without the addition of chemicals provides the means of upgrading biological treated sewage for re-use in industrial and agricultural applications or to obtain an effluent quality superior to that of the General Standard.

Various types of sand filters are available such as “Slow Rapid Gravity” and “Pressure” filters each of which have specific applications in different circumstances.

Sand filtration should not be considered to be a substitute for adequate biological treatment. A biological poor effluent contains very fine colloidal material which does not settle readily and may also not be filtered out. Effluent fed to filters should be settled, completely stable, and well nitrified.

6.6 OPTION F: POND SYSTEMS

Pond systems provide low-cost sewage treatment system for small communities. Their function relies on the natural self-purification process that occurs in the body of water and therefore is dependent on natural conditions such as temperature, sunshine, wind action, humidity, exposure time, etc. The quality of the pond effluent will improve with longer exposure to these conditions.

Treatment of sewage in a pond system is suitable for locations where:

- i. the population is too small to justify a conventional treatment system;
- ii. the land is inexpensive;
- iii. large flat open areas of land available;
- iv. climatic conditions are suitable;
- v. loadings fluctuate seasonally; and
- vi. funds are limited.

7 DEFINE DESIGN/PLANNING CRITERIA

7.1 KEY DESIGN CRITERIA

Sterkspruit is the business hub that is serving the surrounding rural areas. As Sterkspruit has a high level of economic activity, it is classified in the Senqu SDF as a secondary urban node. In the Joe Gqabi SDF it is also recognised as an important node, the second largest to Aliwal North in the Maletswai Municipality.

With the growth in the level of urban settlement there is also a need to improve the central business district to enable development. Sterkspruit plays a vital role in providing higher order services and retail facilities, not only to its resident population but also to the surrounding rural communities. Both the Joe Gqabi DM and Senqu Municipality SDF recommend that this centre be prioritised and attention given to improve infrastructure and services and as well as sustainable human settlement (with a range of housing options, infrastructure upgrade, social and economic amenities).

7.2 SHORT TERM PLAN

Emergency works: Package plant with 1 Mℓ/day

Continuous discussions with the Department of Water and Sanitation have led to a decision that a temporary wastewater treatment package plant with a capacity to treat 1 Mℓ/day household sewerage be installed. It would be able to be moved to various sewer related problem areas within the boundaries of the Joe Gqabi District Municipality after the commissioning of the new wastewater treatment works. The package plant will be in operation until a new activated sludge or bio-filter plant is constructed.

7.3 LONG TERM PLAN

As a matter of urgency and to prevent any further contamination of the natural water ways in the Sterkspruit area, the phasing of the proposed works is divided as follows.

7.3.1 PHASE 1: DRAINAGE ZONE ONE

This zone includes Sterkspruit and Tapoleng development of bulk infrastructure and the construction of the first phase WWTW (2 Mℓ/day). Part of the implementation plan for the construction works includes an EIA investigation of potential sites where construction works are proposed and a detailed geotechnical investigation into the proposed area

where the WWTW will be constructed. The capacity (0.5Mℓ/day) of the existing oxidation ponds is inadequate for the design flow and it is overflowing. The bulk infrastructure will consist of pump lines, gravity lines and pump stations as required.

7.3.2 PHASE 2: DRAINAGE ZONE TWO

This zone represents the bulk infrastructure to connect the Esilindini to the WWTW. The constructions of the different pump stations in different zones can commence after the completion of phase one WWTW (2 Mℓ/day). Pump stations will be built as required for the drainage zones and first priority will be given to the areas that can drain by gravity to the WWTW. With the current population in Sterkspruit, Tapoleng and Esilindini, the WWTW (2 Mℓ/day) with the package plant (emergency) can cope with the flow rate; otherwise the WWTW needs to be upgraded to a 4 Mℓ/day plant.

7.3.3 PHASE 3: DRAINAGE ZONE THREE

The bulk infrastructure for the Mokhesi will be constructed during this phase. This will consist of bulk gravity reticulation, pump stations and pump lines. If the WWTW has not been upgraded during Phase 2, the WWTW needs to be upgraded to a 6 Mℓ/day plant which will cater for the demand of 2035.

7.4 SCOPE OF WORKS

The scopes of infrastructure development in Phase 1, which have been identified in the 'Scoping Report' are detailed below.

7.4.1 WASTEWATER TREATMENT WORKS

A 2 MI/day capacity treatment works comprises of following units:

- Inlet works with screening and de-gritting
- Flow measurement
- Biological reactor
- Petro process
- Secondary sedimentation tanks
- Maturation rivers
- Disinfection
- Sludge handling facility

7.4.2 SEWER LIFT PUMP STATIONS

There are several natural drainage areas within the Sterkspruit area to be covered by the proposed bulk connector sewerage systems, which will demand pumping of sewage to the proposed new WWTW via intermediate pump stations. Some of the identified drainage areas are:

- Portions of Tapoleng draining the south, the north, the west and the east.
- The majority portions of Sterkspruit drain to the east.

7.4.3 BULK SEWER LINE

The 'Scoping Report' has estimated the requirement of about 26.55 km of bulk sewer lines of diameters varying from 160 mm to 400 mm to cover the Sterkspruit area along with a number of manholes and other associated features and fixtures.

7.4.4 ELECTRICITY SUPPLY

In order for all the pump stations and the WWTW to run, different electricity supply points will be needed. This will be identified during the detail design stage and the planning will be communicated to Eskom.

A standby power generating unit is also included in the extension with the intention of that unit being able to sustain the most critical process components of the new works during grid power failures.

7.5 DESIGN PHILOSOPHY AND CRITERIA FOR NEW WWTW

7.5.1 HYDRAULIC CONSIDERATIONS

The following hydraulic design criteria shall be used:

- Peak factors of 2.5 for PDWF and 3.5 for PWWF shall be adopted for hydraulic design of conduits
- A Manning n value of 0.015 shall be used for the design of concrete channels
- A conservative value 0.05mm for GRP pipe roughness co-efficient shall be used for the Darcy-Weisbach and Colebrook White equations
- Flow conduits shall be designed to achieve self-cleansing velocities of at least 0.7 m/s once a day

7.5.2 PROCESS CONSIDERATIONS

The following parameters, criteria and assumptions shall be used in the process design:

- A nitrate removal biological process with a minimum operating sludge age of 15 days
- Process temperatures between 14 °C and 35 °C
- A standard oxygen transfer rate (SOTR) of 2 kg O₂/kWh from the vertical shaft aerators is assumed
- Dissolved oxygen (DO) of 2 mg/l and peak oxygen demand factor of 1,3
- Internal A-recycle ratio of 3:5 inside the reactor channels
- A diluted sludge volume index (DSVI) of 150 ml/g has been used for the design of clarifiers
- The sludge gravity thickener loading rate shall be between 1 and 3 kg/m²/h and the maximum hydraulic overflow rate shall be 0.7 m³/m²/h
- Sludge shall be thickened to minimum settled solids concentration of 3% and the capture efficiency is assumed to be at least 97 %
- Disinfection will be by gas chlorination

7.5.3 LIQUID AND SLUDGE UNIT PHASES

7.5.3.1 INLET WORKS

The equipment for the inlet works will cater for a flow of 2,5 Ml/day and will include coarse hand-raked screen, rag catcher, manual grit channels and flume, ultrasonic flow meter with data logger. By-pass and overflow facilities shall be provided with full automation to direct excess flow either to the downstream units or a balancing tank should this be required. However, it is preferable that the new inlet works be designed to handle hydraulic peaks of 3.5 times the ADWF.

7.5.3.2 PRIMARY SETTLING TANK DESIGN

No primary settling will be provided.

7.5.3.3 BIOLOGICAL TREATMENT DESIGN

The biological treatment design consists of the following:

- 3 460 m³ reactor and 22 m diameter SST with chlorination channels and chlorination- and control building
- Petro division box, facultative pond 2 500 m³ and Petro recycle pump station and associated pipe work

7.5.3.3.1 REACTOR (3 460 M³)

The reactor is a circular reinforced concrete water retaining structure with a life expectancy exceeding 30 years with free span bridge aerators complete with walkway and hand railing.

The inner reactor will have separate anoxic reactor consisting of:

- Two 3 kW slow speed transfer mixers with patented bottom A-recycle (3 to 7 ADWF adjustable recycle rate)
- Two 7.5 kW slow speed vertical radial mixers with patented RAS recycle. (0.5 to 1.5 ADWF adjustable recycle rate)

The outer reactor consists of:

- Aerobic reactor - Five 37 kW Vertical aerators
- The aerators are equipped with VSDs and the aeration will be adjusted through the use of DO meters

7.5.3.3.2 PETRO PROCESS

The advantages of the Petro process are the following:

- i. C:N ratio less disturbed resulting in bigger reduction before exceeding the C:N ratio capacity where it starts to inhibit the de-nitrification process when compared to anaerobic ponds and the conventional oxidation ponds
- ii. In the Petro process algae can settle due to the formation of Polysaccharide in the readily biodegradable portion of the facultative pond.
 - a. Polysaccharides are polymeric carbohydrate molecules composed of long chains of monosaccharide units bound together by glycoside bonds
 - b. This process condition was discovered and patented by PG Meiring in conjunction with WRC

- c. No other pond system generating algae can produce settle-able algae
- iii. The Petro process has less smell due to aerobic layer over the top
- iv. Algae is used to reduce the loading to the reactor, of which only the Petro produces algae that can settle, as well as a reduction of Nitrogen more efficient than primary settling and digestion
- v. Effluent can comply due to the system flexibility and the option to adjust to organic loading
- vi. Far less sludge generation than the conventional primary settling tanks and or anaerobic ponds
- vii. Petro recirculation two pumps are proposed, duty standby providing recirculation at a flow of ADWF.

Mode of Operation

The operation of the system relay on, the development of a large biofilm surface area and for that it needs 1) oxygen and 2) substrates from the bulk liquid.

The design of the aerator must ensure high displacement performance and minimises the risk of clogging. Large quantities of water particles must be sprayed in the air and the agitation of the water surface must intensify oxygen entrainment.

The recommended operating parameters for the new reactors are indicated in **Table 7.1** below:

Table 12: Required Effluent Quality

Substance / Parameter	Unit	General Limit
Faecal Coliforms	per 100 ml	1000
Chemical Oxygen Demand (COD)	mg/l	75*
PH		5,5-9,5
Ammonia (ionised and un-ionised) as Nitrogen	mg/l	6
Nitrate/Nitrite as Nitrogen	mg/l	15
Chlorine as Free Chlorine	mg/l	0,25
Suspended Solids	mg/l	25
Electrical Conductivity	mS/m	70
Electrical Conductivity maximum	mS/m	150
Ortho-Phosphate as phosphorous	mg/l	10
Fluoride	mg/l	1
Soap, oil or grease	mg/l	2,5

7.5.3.4 DISINFECTION

The gas chlorination facility will be designed to serve all the phases of the upgrading of the plant. Variable dosage rates of between 2 and 7 mg/l and auto changeover are catered for.

The following safety and emergency equipment will be supplied in order to comply with regulations:

- Spanners to allow cylinder changes set
- Full gas mask (canister set)
- Canister for gas mask (chlorine gas use)
- Chemical gloves
- Set of safety signs (in English and Xhosa)
- Gas mask box with breakable glass and key
- Test ammonia
- First aid kit (special for Chlorine room only)
- Full BA set with compressed air cylinder

7.5.3.5 SLUDGE TREATMENT AND HANDLING

Sludge wasting shall take place from either the underflow of the clarifiers or at the overflow of the reactors. Providing both these facilities will ensure that operational staff are able to waste large quantities of sludge via the clarifier underflow when the total sludge mass in the process needs to be reduced. The reactor overflow should however be used for sludge wasting during normal circumstances to control the sludge age. Thickening of waste activated sludge will be required prior to dewatering thereof. The volume of sludge wasted daily will depend largely on the design of the reactor and the type of process selected.

By wasting the sludge into the oxidation ponds of the Petro system, aerobic sludge digestion takes place resulting in additional sludge storage capacity in comparison to conventional sludge lagoons. Due to the size of the secondary pond system and the Petro recycle stream, it is estimated that the pond system will have a 20 year cycle before de-sludging will need to take place.

7.6 CIVIL REQUIREMENTS

7.6.1 TOPOGRAPHICAL SURVEY

A topographical survey of the proposed site has been conducted and used as the base plan for design drawings. Known pegs on site have been located and recorded and will be protected during the duration of the construction activities or reinstated where these have been disturbed as prescribed by the Land Survey Act.

7.6.2 GEOTECHNICAL INVESTIGATION

A geotechnical investigation needs to be done.

7.6.3 STRUCTURAL CONSIDERATIONS

The following structural requirements are recommended and shall be used in the design of the new structures:

- Maximum design foundation bearing pressures shall be 150 kPa;
- Design imposed loading on floors and slabs shall be 5 kPa;

- 75mm blinding to be provided under all reinforced concrete structures and blinding to be placed within 3 hours of exposure of the in-situ clay to minimize moisture variation;
- For all water retaining structures, 28-day concrete cube compressive strengths for walls, slabs and floors shall be Class 35/19. The minimum cement content in water-retaining structures shall be 325 kg/m³, and the maximum cement content shall be 400 kg/m³ in reinforced concrete. The maximum water: cement ratio for water-retaining structures shall be 0.53;
- Minimum cover to the reinforcing steel in walls, slabs and floors shall be 40 mm;
- Pull-out bars for water retaining structures shall not be permitted;
- The exposure conditions for the concrete shall be regarded as “very severe” and protective measures in the form of approved epoxy-cement sealing compounds shall be specified;
- Corrosion and erosion resistant linings to the formed concrete surfaces shall be put in place at areas of high turbulence;
- A horizontal joint required as a “kicker” (in wall above base or floor slab), shall be compulsory to all water retaining structures;
- Where pipes pass through walls of water retaining structures, they shall be cast into the wall simultaneously with the casting of the wall – only in exceptional cases will box-outs for the installation of pipes be allowed;
- All water retaining structures shall be tested for water-tightness. The stabilizing period shall be 7 days for a maximum design-crack width of 0.1mm or 21 days for 0.2mm;
- All brickwork shall comply with SABS 227. All joints in brick walls shall be 10 mm wide; and
- All structural steelwork for ladders, steps, hand railing and open-floor grating shall be galvanised mild steel with additional corrosion protection.

7.6.4 SITE ACCESS

A major portion of the access road to the WWTW is in a good condition and upgrading of this road is not regarded necessary.

7.6.4.1 INTERNAL ROADS

It is suggested that new roads be constructed within and around the new extensions. The roads will have a minimum of 5,5 m width with edge restraints such as mountable kerbs. The roads should preferably be surfaced in concrete bricks due to its lower maintenance requirements. The surfacing of the roads will be undertaken at completion of the project so that construction traffic does not damage the roads.

7.6.4.2 EARTHWORKS

It is a specific design condition that the structural components of the new works i.e. primary settling tanks, reactors and secondary settling tanks, should be at a level that the pumping (energy use) is at a minimum. Excavation and levelling will be planned from the topographical survey information.

7.6.4.3 LANDSCAPING AND GRASSING

It was proposed that grassing will be done on all open landscaped areas, embankments slopes and new road verges. The maintenance of grassed areas presents problems for the staff at the WWTW and the areas to be grassed will be revisited when the work is nearing completion.

7.6.4.4 IRRIGATION

The existing works has an irrigation system installed. Irrigation water will be required for the landscaped grass areas of the new plant and therefore piping and sprinklers will have to be provided and connected to the existing network or new network. The position of stand-pipes/sprinklers and the network layout will be finalised once the areas to be grassed have been agreed upon.

7.6.4.5 SITE STORM WATER

It is imperative that no storm water system (clean water) is connected to wastewater (dirty water) or sludge conduits or structures as the works are not designed to accommodate storm water flows from the plant. The storm water drainage arrangement for the new WWTW envisages that the roads will be employed for major drainage with runoff flows directed towards the existing storm water system. It will be part of the design to keep the clean and dirty water separate.

The whole portion of land on which the existing works and the extension are located will be surrounded by a berm and foot drain designed to divert storm water from the surrounding areas entering the WWTW precinct.

7.6.4.6 POTABLE WATER

No major additional potable water requirements are envisaged and the existing potable water system at the site is regarded adequate for future needs. New pipelines may be required from the existing supply to cater for additional needs.

7.6.4.7 EXISTING SERVICES

Existing services within existing WWTW site will be located and plotted on the drawings.

Notwithstanding the collection and verification of the services on drawings, all existing services will need to be located during construction where these may be affected by the works. Services shall be located and carried out by careful hand excavation at such positions and to such dimensions as shown on the drawings.

7.6.4.8 PERIMETER SECURITY

Vandalism and theft have had a major impact on the operations and maintenance of the WWTW. As part of the extension, a new and more secure fence will be erected around the whole WWTW and following the storm water diversion berm to maximise visibility.

7.6.5 ELECTRICAL AND INSTRUMENTATION REQUIREMENTS

This section covers new electrical installations required for the new module or works.

7.6.5.1 TRANSFORMERS

Currently the WWTW is fed by 25 kVA transformer. It was determined that the package plant currently uses 10 kW, or 25 kVA, at full load. It will therefore be necessary to extend the feeding capacity to the WWTW. An additional 466 kVA will be required for phase 1 and 2. The total demand with the package plant will therefore be 500 kVA. Phase 3 will need an additional 405 kVA capacity and therefor bring the total load to 895 kVA.

In order to supply the electricity as needed the municipality must apply for a 1 MVA transformer. The tariff structure for 1 MVA and 500 kVA is the same. There is a difference in the capital cost.

7.6.5.2 ELECTRICAL DISTRIBUTION

Electrical distribution will be addressed during the detail planning of the WWTW.

7.6.5.3 PLANT AUTOMATION

Automation developments for the plant will be done in a manner allowing ease of work for plant operators. Full automation of the plant with complete feedback and control systems will be considered. It is important that automation equipment and systems that are installed for this project are designed and implemented in such a way that it can accommodate further automation in the future.

The recommended control system to be installed involves various PLCs (programmable logic controllers). The PLC will be housed inside the relevant MCC combined with an integrated relay and termination panel. All VSDs (variable speed drives) and field instrumentation or measuring equipment (i.e. pressure switches, level meters, flow meter, electrically actuated penstocks) will also have to be linked to the relevant PLC to allow control and feedback.

The PLCs will be connected in an optic fibre cable ring, which will originate and terminate at the main control system SCADA (Supervisory Control and Data Acquisition). The cable ring will enable communication between the PLCs and the SCADA system, despite a cable failure between any of the PLC nodes. The precise configuration of the layout and process on the screens of the SCADA system is left for the system engineer's advice and the operator's requirements.

All control will be housed in the one control room. This will enable the plant operators to work from a central position.

8 FEASIBILITY OF VARIOUS OPTIONS

In the Joe Gqabi District Municipality there are oxidation ponds and activated sludge systems. (DWA, 2012) The activated sludge systems have sludge lagoons, drying beds and land disposal of sludge. In order to keep to known technology in the area only oxidation ponds and activated sludge systems will be discussed as feasible options.

8.1 POND SYSTEM

As indicated in the report, the pond system will not work due to a lack of space to construct the works. More than 2 Ml/day does not conform to the general limit set by DWS due to size and treatment technology.

8.2 ACTIVATED SLUDGE SYSTEM

Activated sludge system is known to the Joe Gqabi District Municipality. The existing ponds are converted to secondary oxidation ponds as part of the PERTO ponds system. The system can be built in phase and are easily upgraded.

9 OPTION ANALYSIS

The applicability of a process is evaluated on the basis of past experience, data from full scale plants, published data, and from pilot-plant studies.

The Joe Gqabi District Municipality has past experience of the activated sludge process and will therefore be able to operate and maintain the system.

APPENDIX A: Scoping Report

APPENDIX B: Maps

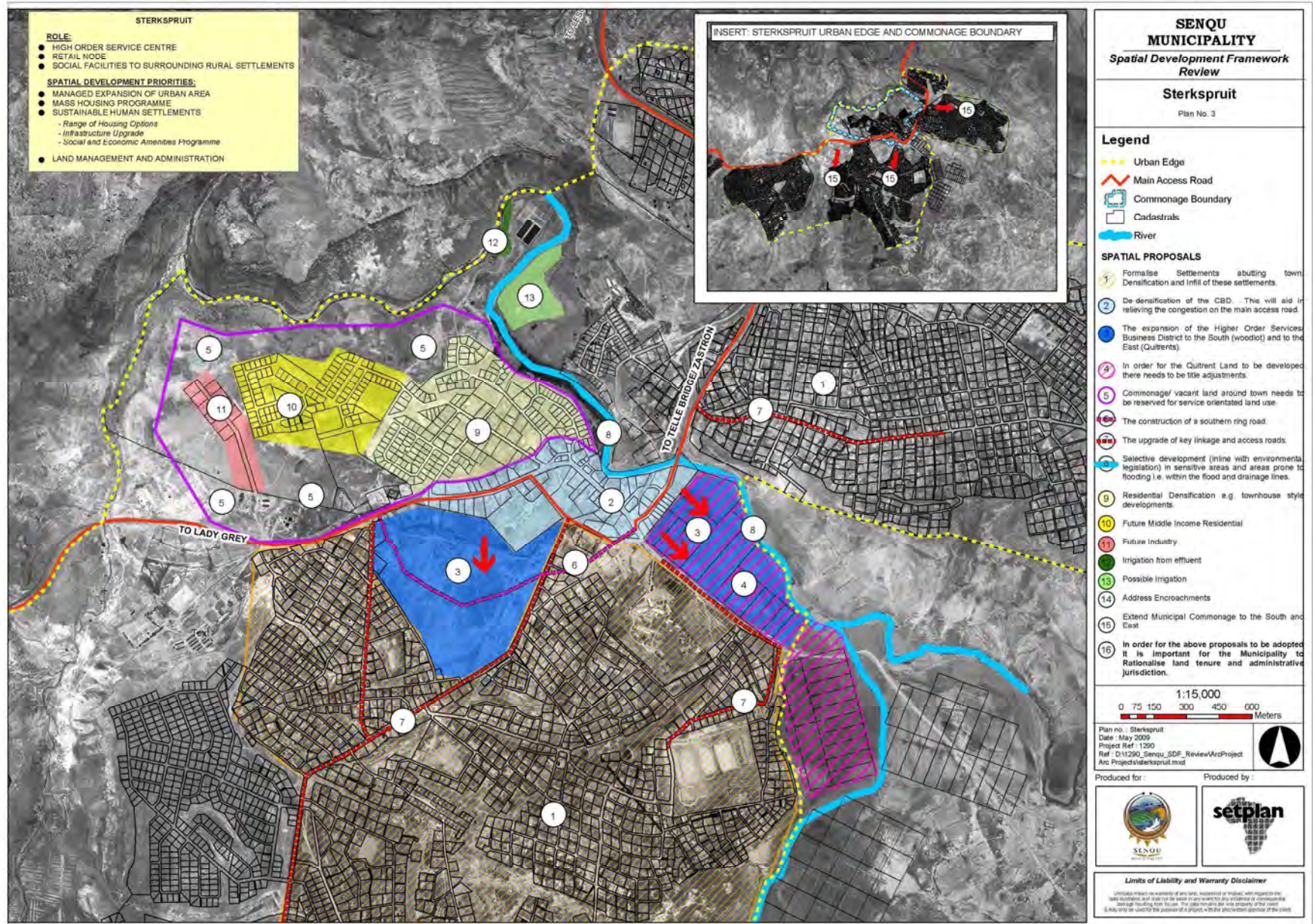

Figure 16: B1 - Sterkspruit SDF

STERKSPRUIT TOWN AND SURROUNDING SETTLEMENTS

HOUSEHOLD COUNT - CENSUS 2011

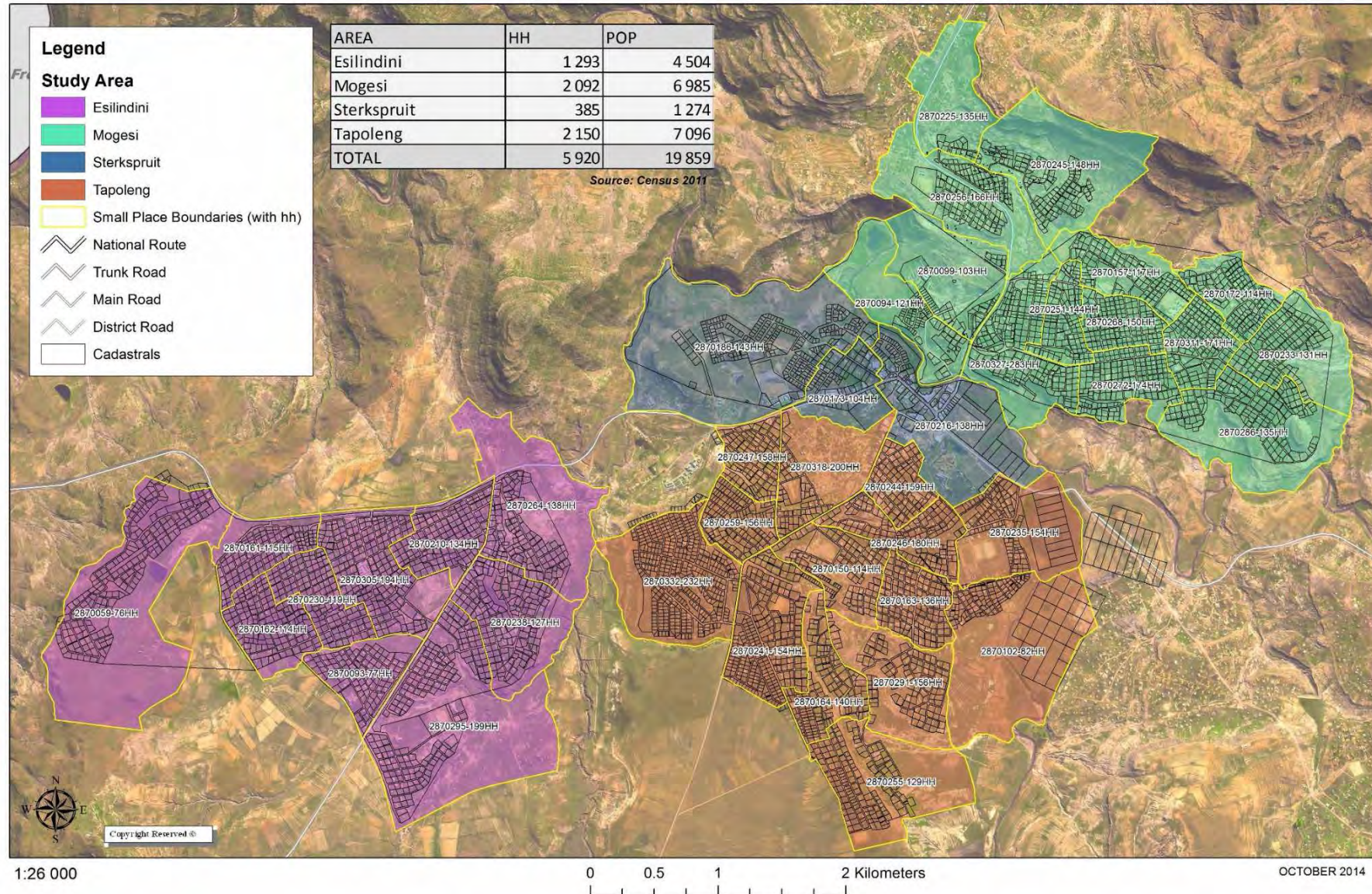
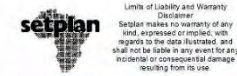

Figure 17: B2 - Population and households of Sterkspruit and surrounding areas (Census 2011)

STERKSPRUIT TOWN AND SURROUNDING SETTLEMENTS

HOUSE COUNT DOT COUNT

setplan
 Limits of Liability and Warranty
 Disclaimer
 Setplan makes no warranty of any kind, expressed or implied, with regards to the data illustrated, and shall not be liable in any event for any incidental or consequential damage resulting from its use.

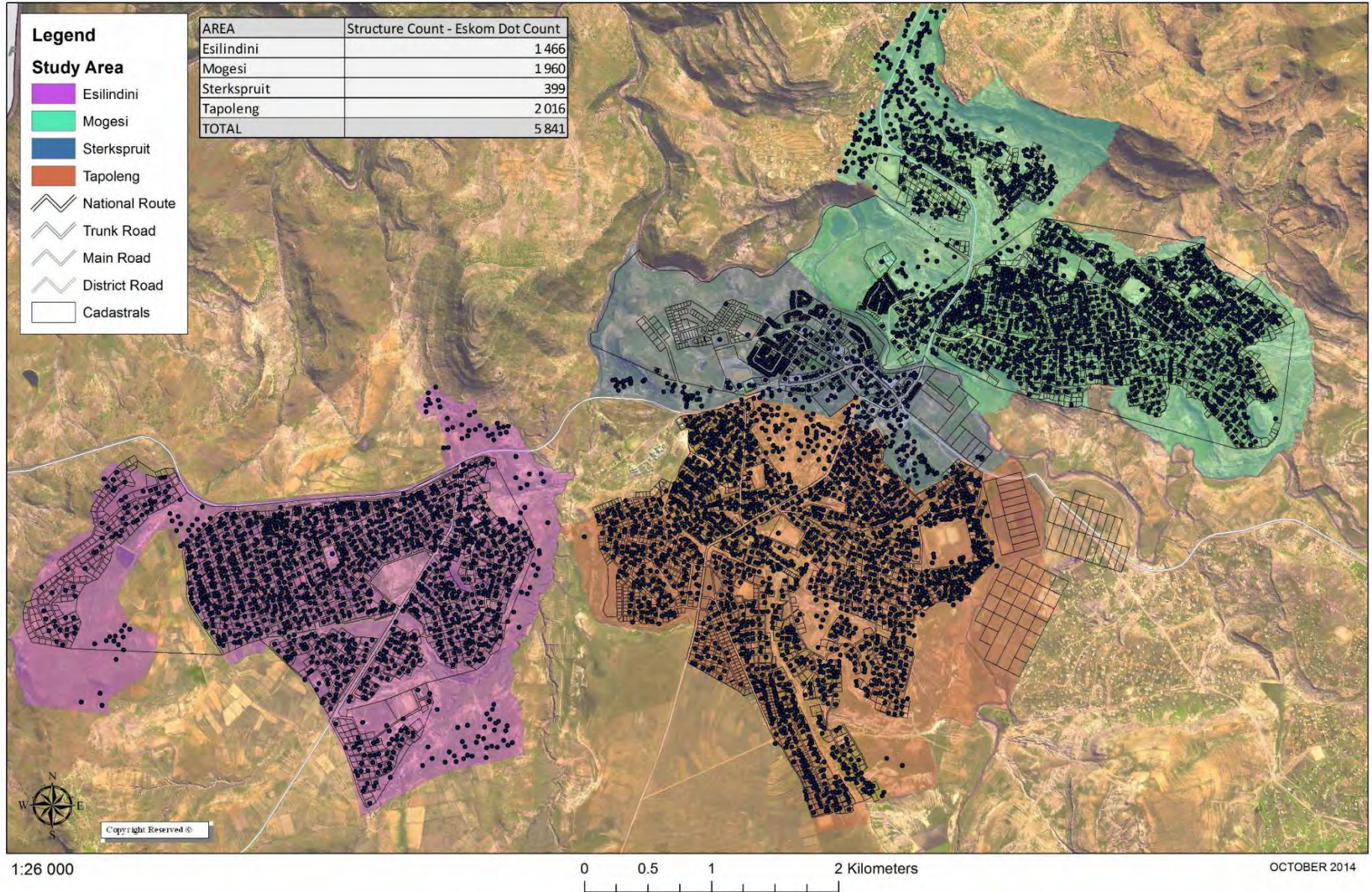

Figure 18: B3 - Structure count (Eskom 2010) count



COMPANY PROFILE

www.ekogroup.co.za



GENERAL INFORMATION

REGISTERED NAME

Eko Group (PTY) LTD trading
as Eko Environmental

REG. NUMBER

2017/ 311178/ 07

VAT NUMBER

4020225811

CONTACT DETAILS



RVN Office Suites,
94 Victoria Road, Park
West, Bloemfontein



info@ekogroup.co.za



+27 51-444-4700



Eko Environmental (Pty) Ltd

COMPANY OVERVIEW

For the last 18 years, EKO Environmental has been providing innovative environmental management services that meets the needs of our clients throughout South Africa.

Based in Bloemfontein- EKO Environmental has completed projects all over the 9 provinces of the Republic.

EKO Environmental is one of South Africa's leading providers of environmental management and consulting and serves a diverse customer base. Our customer base spans over several industries- including Agriculture, Energy, Mining, Oil & Gas, Water, Engineering and Construction, as well as numerous government agencies.

These customers rely on EKO Environmental to deliver a broad range of services such as integrated water and waste management, geological and geohydrological investigations, botanical and soil surveys and rehabilitation, GIS and data management, pollution control, environmental impact assessments and water use licence applications- to name a few.

OUR APPROACH

TO SUCCESS

EKO Environmental provides professional, innovative services and cost-effective solutions to environmental problems - allowing our clients to conduct their various activities at a minimum cost and within the required legal framework.

We are driven to deliver value to our clients through providing them with safe and sustainable project solutions, developing the full potential of our employees and effectively contributing to the communities we work in.

Our team has extended expertise in a variety of environmental fields as well as in the organisation of larger environmental management projects- that involve outside contracted expertise for specialist investigations.

Our broad service network, world class technologies and professional teams enable EKO Environmental to effectively tackle any environmental problem at its origin and reduce environmental costs for the client- making EKO Environmental one of the top choices among environmental management companies.

When evaluating environmental management service companies, clients know they can rely on EKO Environmental.

TEAM OF EXPERTS

Louis van Niekerk



Education:

1988 - B.Sc. Geochemistry Geology and Geohydrology

1989 - B.Sc. Hons. in Geohydrology

1991 - M.Sc. Geohydrology (Surface & Groundwater Pollution)

Registered as a professional scientist

Pr.Sci.Nat 400077/93

Member of the Institute of Waste Management

Member of the Ground Water Division of the Geological Society of South Africa

Specialist Fields:

Environmental control & management

Aquifer testing

Groundwater exploration and resource evaluation

Groundwater management

Monitoring and evaluation of groundwater pollution

Borehole siting and drilling supervision

Site investigation and design of solid waste disposal sites

Contact Information:

Cell: +27 82-652-2992

Email: louisvn@ekogroup.co.za

OUR APPROACH

TO SUSTAINIBLE RESOURCE MANAGEMENT

EKO Environmental believes in a community- and GIS-based approach to sustainable resource management and development.

A combined approach utilising GIS, Participatory Rural Appraisal (PRA) and Focus Group Discussion (FGD) has been developed for resource mapping in an area. This model integrated GIS and participatory tools to include the voices of the community in assessing available resources and needs.

The resource mapping framework, developed using PRA with local community people is aimed at sustainable resource management, and ArcView GIS is used to digitise the resource maps as a Decision Support System (DSS).

A detailed assessment and analysis of the quality, quantity and physical status of resources is first mapped in the field and then digitised using GIS.

FGD-based interaction with the community reveals stakeholders' opinions on land and water body management.

This data is used to develop a sustainable model for improving the management and development of natural resources in any area.

When sustainable resource management and development is needed you can rely on EKO Environmental.

TEAM OF EXPERTS

Alré Groenewald



Education:

2007 - B.Sc. Hons. in Geohydrology

Registered as a professional scientist

Pr.Sci.Nat Earth Science

Specialist Fields:

Determination of aquifer vulnerability at various waste sites

Development and management of ground- and surface water monitoring programs

Environmental Impact Assessments

Environmental Management Reports

Hydro geological and hydrological investigations of power station pollution problems

Integrated water and waste management

Mining authorizations

Waste license applications

Water Quality Assessments

Water use license application

Contact Information:

Cell: +27 83-267-0128

Email: alre@ekogroup.co.za

OUR APPROACH

TO BBEE

Broad Based Black

Economic Empowerment has the potential to redress inequality, boost economic growth and create a better life for all. EKO Environmental believes that B-BBEE is a component of the broader transformation imperative in South Africa. Currently EKO Environmental is rated a level four B-BBEE contributor.

As a responsible

corporate citizen, EKO Environmental has actively demonstrated its commitment to Transformation and Sustainability through strategies that address all the elements of the B-BBEE scorecard.

EKO Environmental

takes a holistic view on transformation and focuses its efforts on both the external and internal environment.

Our external

transformation efforts encompass our investments in BEE ownership transactions, engagement with our suppliers and ensuring that we continuously focus on diversifying our supply chain through the support of small business and through the communities we impact. We continue to focus on procurement from B-BBEE rated suppliers with a particular focus on procurement from black women owned suppliers. Our business is conducted with the imperative to support black-owned businesses and those that meet at least a level 4 of compliance according to the B-BBEE scorecard.

Our internal

transformation efforts are focused on our people and creating a more inclusive and diverse workforce who are trained and developed to meet our strategic business objectives. We continuously seek to promote skills development and to empower youth by providing learnerships and bursaries to previously disadvantaged groups.

We are currently

in a process of reshaping our transformation strategy for the next 3 years and ensuring that we focus on the various elements where we have gaps. The company is committed to principles of transformation and would undertake processes that are sustainable and have true grass roots impact, rather than engage in behaviour that seeks to "buy points" on the B-BBEE scorecard.

TEAM OF EXPERTS

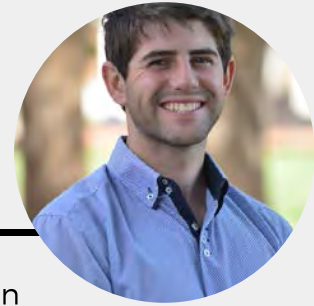

Richard Williamson

Richard Deneys Williamson

recently completed his Masters degree in Environmental management at the University of the Free State where he worked as a research assistant during his studies. In that period he co-authored several academic papers and attended conferences, of which he was a speaker at some. In addition he was responsible for the maintenance and operation of the wet laboratory that was run by Centre and conducted routine water sampling and analysis.

Richard has recently started working as a Scientist at Eko Environmental where he has been in charge of several projects. These include the environmental impact reports for township establishments, chicken houses, diesel depots, mining permits and water use licenses to name a few. In addition he is also responsible for all environmental compliance monitoring and auditing at Eko Environmental and has experience auditing road construction and rehabilitation, construction of schools and township establishments as well as compliance to licenses such as water use licenses.

Education:

2014 - B.Sc. Hons Geology

2017 - M.Sc. Environmental
Management

Registered as a professional scientist
Pr.Sci.Nat Earth Science

Specialist Fields:

Auditing

Basic Assessment Reports

Environmental Control Officer

Environmental Impact Assessments

Environmental Management Reports

GIS and data management

Contact Information:

Cell: +27 76-193-9311

Email: richard@ekogroup.co.za

OUR APPROACH

TO CLIENT LOYALTY

At EKO Environmental we pride ourselves in building strong relationships with our clients and delivering top quality job performance. We do this by providing innovative services and cost-effective solutions to environmental problems - allowing our clients to conduct their various activities at a minimum cost and within the required legal framework, while maximising their profits.

We are driven to deliver value to our clients through providing them with safe and sustainable project solutions, developing the full potential of our employees and effectively contributing to the communities we work in.

If you want loyal clients, amazing client service is a must. We allow our clients to evaluate every interaction he or she has with our staff.

This means that our staff is always friendly, helpful and efficient; our client support team is easy to access and able to solve problems in a timely fashion; and our business works to answer questions quickly - even on social media.

At EKO Environmental we make an effort to collect feedback from clients and listen to it. This feedback allows us to improve the way we conduct our business.

When evaluating environmental management service companies, clients know they can rely on EKO Environmental.

TEAM OF EXPERTS



Martin van Niekerk

Martin van Niekerk is currently in his first year at EKO Environmental. "I pride myself in my ability and willingness to improve through learning new skills. My aim is to be the best at what I do, while providing top quality job performance and building client loyalty." Martin's duties include examining data to determine patterns and trends in economic activity; and conducting research to collect market data and samples. This data is used to form predictions obtained from our research to inform, influence, and improve the business decisions of clients and agricultural organisations. This data collection and market analysis allow our clients to maximise their profits through increasing agricultural outputs and productivity. Martin also assists in Basic Assessment Reports, Environmental Impact Assessments and GIS and data management etc.

Education: 2019 - B.a. Agricultural Economics

Specialist Fields:

Determining patterns and trends in economic activity
Basic Assessment Reports
Data collection and market samples
Economic research reports and data analysis
Environmental Impact Assessments
Environmental Management Reports
GIS and data management
Construction of business plans and profit maximisation models

Contact Information:

Cell: +27 72-180-2066

Email: martin@ekogroup.co.za

FIELDS OF EXPERTISE

MINING AUTHORISATION APPLICATION

Mining permits, Environmental authorisation, Application fees, Notifying and Consulting affected parties.

ENVIRONMENTAL IMPACT ASSESSMENTS

Assessment of the environmental consequences of a plan, policy, program, or projects prior to the decision to move forward with the proposed action.

SOLID WASTE MANAGEMENT

Activities required to manage waste from its inception to its final disposal. Includes the collection, transport, treatment and disposal of waste, while monitoring and regulating the waste management process.

ENVIRONMENTAL AUDITING

Process of assessing activities and services to comply with relevant statutory and internal requirements. Facilitating management control of environmental practices.

ISO14001 IMPLEMENTATION AND AUDITING

International standard for organisations to minimize how their operations negatively affect the environment; comply with applicable laws, regulations, and other environmentally oriented requirements.

WATER USE LICENCE APPLICATIONS

Applications for water use licences and specialist studies for the activity that requires a licence.

INTEGRATED WATER AND WASTE MANAGEMENT

Handling wastewater, to make it suitable to either be recycled into a water system or to be disposed of in an environmentally conscious manner.

PUBLIC CONSULTATION PROCESSES

Regulatory process by which the public's input on matters affecting them are gathered. The main goals are improving efficiency, transparency and public involvement in large-scale projects or laws and policies.

WATER QUALITY ASSESSMENTS

Assessment of the degree to which water is clean and usable for variable activities.

GIS AND DATA MANAGEMENT

Capturing, storing, analysing, managing, and interpreting all types of geographical data.

DEVELOPMENT AND MANAGEMENT OF GROUND- AND SURFACE WATER MONITORING PROGRAMS

Measuring the quality of groundwater and surface water- including sediment quality, depth to watertable, trends of watertable and salinity.

BIOMONITORING

Assessing the state and changes in ecosystems, components of biodiversity and landscape, including the types of natural habitats, populations and species.

GEOLOGICAL AND GEOHYDROLOGICAL INVESTIGATIONS

Evaluations for potential wastewater disposal alternatives, Spray irrigation systems, Well installation, Sink holes, Wetland mitigations, Water supply levels, Groundwater levels, etc.

HERITAGE IMPACT ASSESSMENTS

The impact of a new development on heritage sites and mitigation measures to limit the effects of that impact.

BOTANICAL SURVEYS

The survey, research and conservation of plant resources, flora and endangered plant species.

SOIL SURVEYS

The systematic examination, description, classification, and mapping of soils in a specific area.

REHABILITATION

The process of returning an area that has been disturbed due to a development, back to the state it was prior to the development.

WATER SUPPLY

Includes Rural or urban project management, Scientific borehole siting, Borehole design and construction, Borehole and aquifer tests, Management of groundwater resources.

POLLUTION CONTROL

The process of reducing or eliminating the release of pollutants into the environment. It is regulated by environmental agencies which establish pollutant discharge limits for air, water, and land.

ATMOSPHERIC EMISSION LICENSE APPLICATIONS

Including Annual Reports, Dispersion Models, Greenhouse Gas Emissions Calculations, and Pollution Prevention Plans.

Relevant Projects

Last 24 Months

PROJECT DESCRIPTION	CLIENT	LOCALITY
Water Use License Application and Basic Assessment for the proposed construction of a gauging weir in the Wilge River on the farms Riverview and Schurwe Poort	Dept of Water & Sanitation	Reitz, Free State
Water Use License Application and Basic Assessment for the proposed construction of a gauging weir in the Vals river on the farm Brandhoek	Dept of Water & Sanitation	Lindley, Free State
Biodiversity and Ecological Assessment for a proposed Township development	Marguerite Cronje	Riemvasmaak, Postmasburg, Northern
Wetland Assessment for the proposed Mangaung Integrated Public Transport Network (IPTN)	GA Environment	Bloemfontein, Free State
Wetland delineation of the proposed upgrading of the Potchefstroom water network with regard to the proximity to the Spitskopspruit	Baker Square	Potchefstroom, North West
BAR for Township establishment on Bloemspruit plot 146, Bloemfontein	Urban Dynamics	Bloemfontein, Free State
EIA for Township establishment on Remainder of farm Bergendal 1706	Urban Dynamics	Bloemfontein, Free State
EIA for Township establishment on Lilyvale plot 30/2313	Urban Dynamics	Bloemfontein, Free State
BAR for Township establishment on Bloemspruit plot 146, Bloemfontein	Urban Dynamics	Bloemfontein, Free State
BAR for construction of Chicken Layer Houses on Farm Tochgeuk 37, Brandfort	Barry Bekker	Brandfort, Free State
BAR for construction of Chicken Broiler Houses on Farm Fransina 2060, Botshabelo	Du Plessis Family Trust	Botshabelo, Free State
Environmental Compliance Monitoring during construction of Dawiesville Primary School	SMEC South Africa (Pty) Ltd	Tweespruit, Free State, South Africa
Environmental Compliance Monitoring during construction of Ebenhaeserhoogte Intermediate School	SMEC South Africa (Pty) Ltd	Wepener, Free State, South Africa
Environmental Compliance Monitoring during construction of Hermana Primary School	SMEC South Africa (Pty) Ltd	Tweespruit, Free State, South Africa
NRA N001-170-2014/2: The rehabilitation and upgrade of the N1 between Ventersburg and the Holfontein Interchange - Environmental Compliance Monitoring	SMEC South Africa (Pty) Ltd	Free State, South Africa
NRA-N001-170-2014/4: Ventersburg Dorpsgronden Quarry - Environmental Compliance Monitoring	SMEC South Africa (Pty) Ltd	Free State, South Africa
NRA N001-170-2014/3: The rehabilitation and upgrade of the N1 between Kroonstad and the Holfontein Interchange - Environmental Compliance Monitoring	SMEC South Africa (Pty) Ltd	Free State, South Africa
The township establishment on the Remainder of Farm Hillandale 2960 - Environmental Compliance Monitoring	CDL (Clarence De Wet Lesela)	Bloemfontein, Free State, South Africa
Section 24 Application for Toll blending Plant, Anderbolt Boksburg	African Group Lubricants (Pty) Ltd	Anderbolt, Boksburg, Gauteng
BAR for Diesel Depot, Hopetown	Al 2 Stadler (Pty) Ltd	Hopetown, Northern Cape
BAR for Diesel Depot, Kimberley	Al 2 Stadler (Pty) Ltd	Hopetown, Northern Cape

Environmental & Compliance Monitoring

Last 24 Months

Name of Project	Project Location	Client	Project Description	Contact
Annual Compliance Audit to the Water Use License for Groengoud Boerdery	North West Province South Africa	Winter Strom Investment 110 CC	Conducted an annual compliance audit in regards to the Water Use License for Groengoud Boerdery	Ms. Lurette Jansen van Rensburg M: 082 325 7179
Annual Audit of Compliance to the Water Use License for West End Diamond Mine	Postmansburg Northern Cape South Africa	Rex Exploraion (Pty) Ltd	Annual Audit of Compliance in regards to the Water Use License for the mine	Mr. Christo Snyman Tel: 0533133945 M: 0835388777
NRA N001-170-2014/3: The rehabilitation and upgrade of the N1 between Kroonstad and the Holfontein Interchange	Free State South Africa	SMEC South Africa (Pty) Ltd	Conducted monthly environmental compliance audits during the rehabilitation and upgrading of the N1 between Kroonstad and the Holfontein Interchange	Deidre De Koker M: 083 272 2538 Tel: 051 411 8720
NRA-N001-170-2014/4: Ventersburg Dorsprongden Quarry	Free State South Africa	SMEC South Africa (Pty) Ltd	Conduct monthly environmental compliance audits while the Ventersburg Dorsprongden Quarry remains active until rehabilitation is completed.	Deidre De Koker M: 083 272 2538 Tel: 051 411 8721
NRA N001-170-2014/2: The rehabilitation and upgrade of the N1 between Ventersburg and the Holfontein Interchange	Free State South Africa	SMEC South Africa (Pty) Ltd	Conducted monthly environmental compliance audits during the rehabilitation and upgrading of the N1 between Ventersburg and the Holfontein Interchange	Deidre De Koker M: 083 272 2538 Tel: 051 411 8722
The construction of Hermana Primary School	Tweespruit Free State South Africa	SMEC South Africa (Pty) Ltd	Conducted monthly environmental compliance audits during the construction of Hermana Primary School	Smiley Marais M: 082 828 9325 Tel: 051 411 8709
The construction of Ebenhaeserhoogte Intermediate School	Wepener Free State South Africa	SMEC South Africa (Pty) Ltd	Conducted monthly environmental compliance audits during the construction of Ebenhaeserhoogte Intermediate School	Smiley Marais M: 082 828 9325 Tel: 051 411 8710
The construction of Daviesville Primary School	Tweespruit Free State South Africa	SMEC South Africa (Pty) Ltd	Conducted monthly environmental compliance audits during the construction of Daviesville Primary School	Smiley Marais M: 082 828 9325 Tel: 051 411 8711

Environmental & Compliance Audits

Last 24 Months

PROJECT	CLIENT	CONTACT PERSON	SAFETY OFFICER
R56 Indwe-Maclear	KBK Engineers	Henk Pretorius E: henkp@kbkengineers.co.za C:	Thys Norval E: mnorval@taupele C: 072 636 2254
N1 Winburg	SMEC	Jan-Hendrik Els E: janhendrike@bviwc.co.za C:	Pierre de Villiers E: pierre_devilliers@wbho.co.za C: 081 588 0808
Ventersburg Quarry	SMEC	Willie Loots E: willie.loots@smec.com C: 083 561 5999	Pierre Henniker E: phe nniker@triamic.co.za C: 079 506 4552
N1 Ventersburg-Hoffontein	SMEC	Kevin Hulley E: Kevin.Hulley@smec.com C: 061 667 4780	John Makhanya E: john.makhanya@grinaker-ita.co.za C: 079 591 1029
N1 Hoffontein-Kroonstad	SMEC	Josef Swanepoel E: josef.swane poel@smec.com C:	Joseph Lebea E: safetyj@hillary.co.za C: 082 941 5359
Free State Schools	SMEC	Smiley Marais E: Smiley.Marais@smec.com C: 082 828 9925	Godfrey Mokoena E: godfrey@ruwaco.co.za C: 072 620 5583
Woodlandhills Development	SMEC	Smiley Marais E: Smiley.Marais@smec.com C: 082 828 9925	Frederik E: Frederik.d@raubex.com C: 076 526 4845 Wimpie Malan (QS) E: wimpie@cdl.co.za C: 082 556 5095
Van Niekerk's Rust	Nick van Niekerk	Nick van Niekerk E: nick.vanniekerk@korg.co.za C: 0834451399	Mr. Strydom (adjacent landowner) E: C:
Bergendal EIA	Urban Dynamics (Pitberg- Renee Haddad)	Ms. Rene Haddad E: C: 078 358 9690	Me. M. Lombaard E: C:
Indwe Quarry Renewal	KBK Engineers	Mr. Vusi Khubekha E: vusi.khubeka@dmr.gov.za Ms. Nontobeko Mdakane E: Nontobeko.mdakane@dmr.gov.za	Deidre Watkins E: deidre.watkins@dmr.gov.za C: 041 396 3900 (DMR office)
Metsimatlé final School Audit	SMEC	Reinhardt Steyn E: steyn.r@sna.co.za C: 071 437 0603	Smiley Marais E: smiley.marais@smec.com C: 083 828 9925
Bergendal EIA, Bloemspruit EIA, Lilyvale BA	Urban Dynamics	Leon E: C:	Munette Lombaard E: munette@udi.co.za C: 078 087 9956
N1 Kroonstad Skole Audits	SMEC	Deidre de Koker E: deidre.dekoker@smec.com C:	Smiley Marais E: smiley.marais@smec.com C: 083 828 9925 Ivan Jacobs E: ivan.jacobs@smec.com C: 083 784 8913
Kimberley intersections	SMEC		Henno van Graan E: henno.van graan@smec.com C: 021 417 2900
Thabong Water Use Licence	LSB	Henk Wolmarans E: hpw@lsbgroup.co.za C: 082 565 4201	Henk Wolmarans E: hpw@lsbgroup.co.za C: 082 565 4201
Klipdam IWWMP	Klipdam Mining Operations	Ben Nell E: bennell@kdmcc.co.za C: 072 313 8134	Roe lien Oosthuizen E: roosthui ze n950@gmail.com C: 084 208 9088



WE SOLVE ENVIRONMENTAL
PROBLEMS.

www.ekogroup.co.za