



Appendix E

PUBLIC PARTICIPATION



Appendix E1

PROOF OF ADVERTS AND SITE NOTICES

ENVIRONMENTAL IMPACT ASSESSMENTS (EIAs) FOR THE PROPOSED DEVELOPMENT OF THE TWO (2) TLI SITSENG 75MW SOLAR PHOTOVOLTAIC (PV) ENERGY FACILITIES AND BASIC ASSESSMENTS (BAs) FOR THE ASSOCIATED 132KV POWER LINES NEAR LICHTENBURG, NORTH WEST PROVINCE

Co-ordinates: 26° 4'19.35"S & 26° 7'29.32"E



Figure 1: Western entrance to Houthaalbomen (PV Site) - off the R505



Figure 2: Left gate post of the western entrance to the Farm Houthaalboomen (Afrikaans site notice)



Figure 3: Left gate post of the western entrance to the Farm Houthaalboomen



Figure 4: Right gate post of the western entrance to the Farm Houthaalboomen (English site notice)



Figure 5: Right gate post of the western entrance to the Farm Houthaalboomen

Co-ordinates: 32°56'55.09"S & 22°32'37.35"E



Figure 6: Eastern entrance to Houthaalbomen (PV Site) - off the R505



Figure 7: Left gate post of the eastern entrance to the Farm Houthaalboomen (Afrikaans site notice)

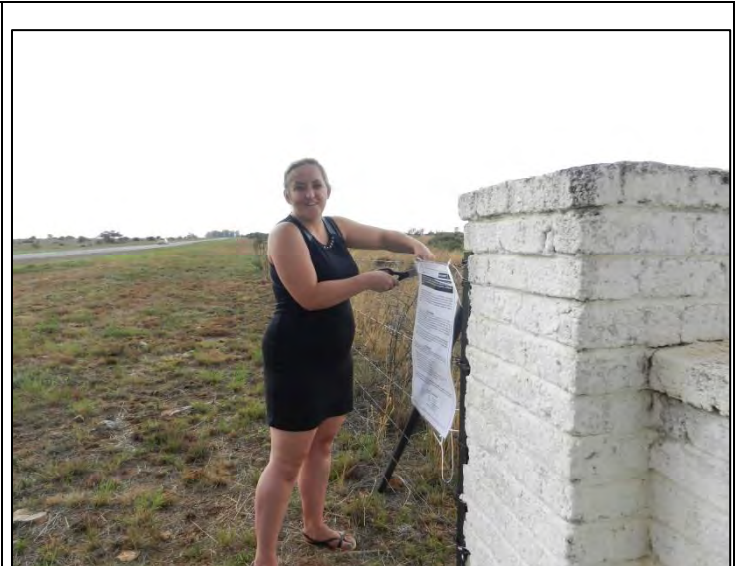

Figure 8: Left gate post of the eastern entrance to the Farm Houthaalboomen (erected by Mariette Steynberg, Socio-Economic Specialist)



Figure 9: Right gate post of the eastern entrance to the Farm Houthaalboomen (Afrikaans site notice)



Figure 10: Right gate post of the eastern entrance to the Farm Houthaalboomen (erected by Mariette Steynberg, Socio-Economic Specialist)

OMGEWINGSIMPAKEVALUERINGS (OIE's) VIR DIE BEOOGDE ONTWIKKELING VAN DIE TWEE (2) TLISITSENG 75 MW FOTOVOLTAÏESE (FV) SONKRAGAANLEGTE EN BASIESE EVALUERINGS (BE'S) VIR DIE GEPAARDGAANDE 132 KV KRAGLYNE NABY LICHTENBURG, NOORDWES-PROVINSIE

Ingevolge die Nasionale Wet op Omgewingsbestuur, 1998 (Wet 107 van 1998) (NEMA), soos gewysig, en die Regulasies op Omgewingsimpevaluering (OIE-regulasies) ingevolge Staatskennisgewing R982, R983, R984 en R985 wat op 4 Desember 2014 ingevolge kennis hiermee dat BioTherm Energy (Edms.) Bpk. SIVEST SA (Edms.) Bpk. aangestel het as die onafhanklike omgewingsevalueringpraktisyn (OEP) ten einde die nodige OIE en openbare deelnameproses vir die bogenoemde voorgestelde projekte te onderneem:

PROJEKBESKRYWING

BioTherm Energy (Edms.) Bpk. (hierna BioTherm genoem) stel die oprigting voor twee (2) Tlisitseng fotovoltaiëse (FV) sonkragaanlegte (hierna die "beoogde ontwikkeling" genoem) naby Lichtenburg, Noordwes-provinsie. Die beoogde ontwikkeling sal bestaan uit twee (2) FV-sonkragaanlegte van 75 MW elk wat as Tlisitseng 1 en Tlisitseng 2 sal bekendstaan. Daarbenewens beoog BioTherm die oprigting van twee 132 kV kraglyne ten einde die beoogde FV-sonkragaanlegte met die bestaande Watershed Hooftransmissiesubstasie (HTS) te verbind. Die oorkoepelende doelwit van die projek is om elektrisiteit op te wek om in Eskom se nasionale kragnet in te voer.

Derhalwe sal twee (2) OIE's onderneem word; een vir elk van die beoogde Tlisitseng FV-sonkragaanlegte. Daarbenewens sal twee (2) BE's onderneem word; een vir elk van die geaardgaande 132 kV kraglyne. Hoewel elke FV-aanleg en die elektriese infrastruktuur apart geëvalueer sal word, word 'n enkele openbare deelnameproses vir al vier (4) beoogde projekte onderneem.

PROJEKLIIGING

Die beoogde projek is geleë in die Noordwes-provinsie, sowat 8 km noordwes van Lichtenburg. Dit is in die Ditsobotla Plaaslike Munisipaliteit geleë, wat deel vorm van die Ngaka Modiri Molema Distriksmunisipaliteit. Die projek sluit die volgende plase in:

- Gedeelte 25 van die plaas Houthaalboom No. 31 (FV-aanleg)
- Gedeelte 2 van die plaas Talene No. 25 (Kraglyne)
- Gedeelte 3 van die plaas Talene No. 25 (Kraglyne)
- Gedeelte 4 van die plaas Talene No. 25 (Kraglyne)
- Restant van Gedeelte 1 van die plaas Lichtenburg Town and Townlands No. 27 (Kraglyne)
- Gedeelte 10 van die plaas Lichtenburg Town and Townlands No. 27 (Kraglyne)
- Gedeelte 24 van die plaas Houthaalboomen No. 31 (Kraglyne)

Ten einde as 'n Belangstellende en/of Geaffekteerde Party (B&GP) te registreer en/of om meer inligting te bekom, moet u asseblief u naam, kontakbesonderhede en die belang wat u by die aansoek het aan die Omgewingskonsultante hieronder:

Andrea Gibb of Lynsey Rimbault	
SIVEST Environmental	
Posbus 2921	Tel: 011 798 0600
RIVONIA	Faks: 011 803 7272
2128	E-pos: andreag@sivest.co.za of lynseyr@sivest.co.za
Webwerf: www.sivest.co.za	

ENVIRONMENTAL IMPACT ASSESSMENTS (EIAs) FOR THE PROPOSED DEVELOPMENT OF THE TWO (2) TLISITSENG 75MW SOLAR PHOTOVOLTAIC (PV) ENERGY FACILITIES AND BASIC ASSESSMENTS (BAs) FOR THE ASSOCIATED 132kV POWER LINES NEAR LICHTENBURG, NORTH WEST PROVINCE

In terms of the National Environmental Management Act, 1998 (Act No. 107 of 1998) (NEMA) as amended and the Environmental Impact Assessment (EIA) Regulations, under Government Notices No R982, R983, R984 and R985 promulgated on 4 December 2014, notice is hereby given that BioTherm Energy (Pty) Ltd has appointed SiVEST SA (Pty) Ltd, as the independent environmental assessment practitioner (EAP), to undertake the required EIA and public participation processes for the above-mentioned proposed projects:

PROJECT DESCRIPTION

BioTherm Energy (Pty) Ltd (hereafter referred to as BioTherm) are proposing to develop two (2) Tlisitseng solar photovoltaic (PV) energy facilities (hereafter referred to as the "proposed development") near Lichtenburg, North West Province. The proposed development will consist of two (2) 75MW solar PV energy facilities, namely Tlisitseng 1 and Tlisitseng 2. In addition, BioTherm are proposing to construct two 132kV power lines in order to connect the proposed solar PV energy facilities to the existing Watershed Main Transmission Substation (MTS). The overall objective of the project is to generate electricity to feed into the national grid.

As such, two (2) EIAs will be undertaken, one for each proposed Tlisitseng solar PV energy facility. In addition, two (2) BAs will be undertaken, one for each associated 132kV power line. Although each PV energy facility and the electrical infrastructure will be assessed separately, a single public participation process is being undertaken for all four (4) proposed projects.

PROJECT LOCATION

The proposed project is located within the North West Province approximately 8km north-west of Lichtenburg. It falls within the Ditsobotla Local Municipality that forms part of the Ngaka Modiri Molema District Municipality. The project includes the following farms:

- Portion 25 of the farm Houthaalboom No. 31
- Remainder of Portion 1 of the farm Lichtenburg Town and Townlands No. 27
- Portion 10 of the farm Lichtenburg Town and Townlands No. 27

AVAILABILITY OF THE DRAFT SCOPING REPORTS FOR PUBLIC REVIEW

The Draft Scoping Reports (DSRs) for the proposed development of the two (2) Tlisitseng 75MW solar PV energy facilities will be available for public comment and review as from **Thursday 29 September 2016 to Monday 31 October 2016** (end of business day). Should you wish to receive an electronic copy of the DSRs (CD) please forward your request in writing to us. Hard copies of the DSRs can be reviewed at the following public place:

VENUE	STREET ADDRESS	HOURS	CONTACT NO
Lichtenburg Public Library	Nelson Mandela Drive, Lichtenburg	Mondays- Thursdays 09h00 – 17h30 Fridays 09h00 – 17h00 Saturdays 09h00 – 12h00	018 633 3904

The reports are also available on SiVEST's website: <http://www.sivest.co.za/>, then browse to the folder '13303 Tlisitseng PV Energy Development'.

To register as an Interested and / or Affected Party (I&AP) and / or to obtain additional information please submit your name, contact details and the interest which you have in the application within 30 days from the date of this notice. Please direct enquiries, **in writing**, to the Environmental Consultants below:

Andrea Gibb	
SiVEST Environmental P O Box 2921 RIVONIA 2128	Tel: (011) 798 0600 Fax: (011) 803 7272 E-mail: andreag@sivest.co.za Website: www.sivest.co.za

OMGEWINGSIMPAKEVALUERINGS (OIE's) VIR DIE BEOOGDE ONTWIKKELING VAN DIE TWEE (2) TLISITSENG 75 MW FOTOVOLTAÏESE (FV) SONKRAGAANLEGTE EN BASIESE EVALUERINGS (BE'S) VIR DIE GEPAARDGAANDE 132 KV KRAGLYNE NABY LICHTENBURG, NOORDWES-PROVINSIE

Ingevolge die Nasionale Wet op Omgewingsbestuur, 1998 (Wet 107 van 1998) (NEMA), soos gewysig, en die Regulasies op Omgewingsimpakevaluering (OIE-regulasies) ingevolge Staatskennisgewing R982, R983, R984 en R985 wat op 4 Desember 2014 ingevolge kennis hiermee dat BioTherm Energy (Edms.) Bpk. SiVEST SA (Edms.) Bpk. aangestel het as die onafhanklike omgewingsevalueringpraktisyn (OEP) ten einde die nodige OIE en openbare deelnameproses vir die bogenoemde voorgestelde projekte te onderneem:

PROJEKBESKRYWING

BioTherm Energy (Edms.) Bpk. (hierna BioTherm genoem) stel die oprigting voor twee (2) Tlisitseng fotovoltaïese (FV) sonkragaanlegte (hierna die "beoogde ontwikkeling" genoem) naby Lichtenburg, Noordwes-provinsie. Die beoogde ontwikkeling sal bestaan uit twee (2) FV-sonkragaanlegte van 75 MW elk wat as Tlisitseng 1 en Tlisitseng 2 sal bekendstaan. Daarbenewens beoog BioTherm die oprigting van twee 132 kV kraglyne ten einde die beoogde FV-sonkragaanlegte met die bestaande Watershed Hooftransmissiesubstasie (HTS) te verbind. Die oorkoepelende doelwit van die projek is om elektrisiteit op te wek om in die nasionale kragnet in te voer.

Derhalwe sal twee (2) OIE's onderneem word; een vir elk van die beoogde Tlisitseng FV-sonkragaanlegte. Daarbenewens sal twee (2) BE's onderneem word; een vir elk van die gepaardgaande 132 kV kraglyne. Hoewel elke FV-aanleg en die elektriese infrastruktuur apart geëvalueer sal word, word 'n enkele openbare deelnameproses vir al vier (4) beoogde projekte onderneem.

PROJEKLIIGING

Die beoogde projek is geleë in die Noordwes-provinsie, sowat 8 km noordwes van Lichtenburg. Dit is in die Ditsobotla Plaaslike Munisipaliteit geleë, wat deel vorm van die Ngaka Modiri Molema Distriksmunisipaliteit. Die projek sluit die volgende plase in:

- Gedeelte 25 van die plaas Houthaalboom No. 31
- Restant van Gedeelte 1 van die plaas Lichtenburg Town and Townlands No. 27
- Gedeelte 10 van die plaas Lichtenburg Town and Townlands No. 27

UITNODIGING OM KOMENTAAR TE LEWER OP DIE KONSEP BESTEKOPNAMEVERSLAE

Die Konsep Bestekopnameverslae vir die beoogde ontwikkeling van die twee (2) Tlisitseng 75 MW FV sonkragaanlegte beskikbaar sal wees vir openbare kommentaar en oorsig vanaf **Donderdag 29 September 2016 tot Maandag 31 Oktober 2016** (teen sluitingstyd). Sou u graag 'n elektroniese kopie van die Konsep Bestekopnameverslae op CD wil ontvang, kan u dit skriftelik by ons aanvra. Gedrukte eksemplare van die Konsep Bestekopnameverslae sal ook by die volgende openbare plek beskikbaar wees vir besigtiging:

PLEK	STRAATADRES	KANTOOR URE	KONTAKNO.
Lichtenburg Openbare Biblioteek	Nelson Mandela Drive, Lichtenburg	Maandae- Donderdae 09h00 – 17h30 Vrydae 09h00 – 17h00 Saterdag 09h00 – 12h00	018 633 3904

Die Verslae is ook op SiVEST se webtuiste beskikbaar: <http://www.sivest.co.za/>, klik dan op die legger '13303 Tlisitseng PV Energy Development'.

Ten einde as 'n Belangstellende en/of Geaffekteerde Party (B&GP) te registreer en/of om meer inligting te bekom, moet u asseblief u naam, kontakbesonderhede en die belang wat u by die aansoek het binne 30 dae vanaf die datum van hierdie kennisgewing indien. Rig asseblief u **skriftelike** navrae aan die Omgewingskonsultante hieronder:

Andrea Gibb	
SiVEST Environmental Posbus 2921 RIVONIA 2128	Tel: 011 798 0600 Faks: 011 803 7272 E-pos: andrea@sivest.co.za Webwerf: www.sivest.co.za

Trokke deur slaggate-nagmerrie

NOORDWESTER – LICHTENBURG – Ter aansluiting by die berig verlede week van die steurnis wat trokke in die dorp op die publiek het, het inwoners van Retiefpark en omliggende buurte naby Ferdi Hartzenberg Rylaan ook hulle misnoë uitgespreek oor trokke wat dag en nag deur die slaggate op die pad knars.

Inwoners is dit eens dat die pad wat voordurend deur groot trokke gebruik word almal in die omgewing se rus verstoort omdat dit veral in die nagtelike ure is, wanneer klank verder trek, dat mens kan hoor hoe hulle hul weg moet baan deur reuse slaggate. Volgens een van die inwoners word tussen 20 en 30 trokke per nag op die pad getel. Ferdi Hartzenberg Rylaan is lankal nie meer slegs 'n teerpad nie. Groot dele van die pad word gekenmerk deur slaggate en groot gedeeltes grond waar die teer al lankal tot niet is.

Die woonbuurte en besighede in die omgewing van die pad is pal toe onder stof

en die veertse, kwekery en Dierewelsyn is moeilik bereikbaar omdat die publiek nie meer kans sien om hul voertuie op dié pad op die spel te plaas nie.

Die pad is al vir baie lank in die swak toestand en is nou onbegaanbaar, miskien moet die Departement van Paaie dringende ondersoek instel en 'n daadwerklike poging aanwend om die pad te herstel sodat padgebruikers dit weer met hul voertuie op die pad kan waag en inwoners nie in die nag deur die klank van trokke wat deur slaggate "val" gehinderd hoef te word nie!



Ferdi Hartzenberg Rylaan wat verby 'n kwekery en die veertse loop is tans 'n warboel van slaggate en stof wat pal in die lug hang.



Ferdi Hartzenberg Rylaan is 'n provinsiale pad wat glad nie in stand gehou word nie. Swaar verkeer veral deur trokke het die pad reeds laat disintegreer. Inwoners van veral Retiefpark word swaar getref deur stofwolke wat oor huise hang en rusverstooring in die nag as trokke deur die slaggate beur.



Oppad na die draai by die Wildteelsentrum word Ferdi Hartzenberg Rylaan gekenmerk deur reuse slaggate en stofpaaie waar die teer al tot niet is. Skade aan trokke is onvermydelik.

SIVEST
Environmental Division

SIVEST
Established in 1952

ENVIRONMENTAL IMPACT ASSESSMENTS (EIAs) FOR THE PROPOSED DEVELOPMENT OF THE TWO (2) TLISITSENG 75MW SOLAR PHOTOVOLTAIC (PV) ENERGY FACILITIES AND BASIC ASSESSMENTS (BAs) FOR THE ASSOCIATED 132kV POWER LINES NEAR LICHTENBURG, NORTH WEST PROVINCE

In terms of the National Environmental Management Act, 1998 (Act No. 107 of 1998) (NEMA) as amended and the Environmental Impact Assessment (EIA) Regulations, under Government Notices No R982, R983, R984 and R985 promulgated on 4 December 2014, notice is hereby given that BioTherm Energy (Pty) Ltd has appointed SiVEST SA (Pty) Ltd, as the independent environmental assessment practitioner (EAP), to undertake the required EIA and public participation processes for the above-mentioned proposed projects:

PROJECT DESCRIPTION

BioTherm Energy (Pty) Ltd (hereafter referred to as BioTherm) are proposing to develop two (2) Tlisitseng solar photovoltaic (PV) energy facilities (hereafter referred to as the "proposed development") near Lichtenburg, North West Province. The proposed development will consist of two (2) 75MW solar PV energy facilities, namely Tlisitseng 1 and Tlisitseng 2. In addition, BioTherm are proposing to construct two 132kV power lines in order to connect the proposed solar PV energy facilities to the existing Watershed Main Transmission Substation (MTS). The overall objective of the project is to generate electricity to feed into the national grid.

As such, two (2) EIAs will be undertaken, one for each proposed Tlisitseng solar PV energy facility. In addition, two (2) BAs will be undertaken, one for each associated 132kV power line. Although each PV energy facility and the electrical infrastructure will be assessed separately, a single public participation process is being undertaken for all four (4) proposed projects.

PROJECT LOCATION

The proposed project is located within the North West Province approximately 8km north-west of Lichtenburg. It falls within the Ditsobotla Local Municipality that forms part of the Ngaka Modiri Molema District Municipality. The project includes the following farms:

- Portion 25 of the farm Houthaalboom No. 31
- Remainder of Portion 1 of the farm Lichtenburg Town and Townlands No. 27
- Portion 10 of the farm Lichtenburg Town and Townlands No. 27

AVAILABILITY OF THE DRAFT SCOPING REPORTS FOR PUBLIC REVIEW

The Draft Scoping Reports (DSRs) for the proposed development of the two (2) Tlisitseng 75MW solar PV energy facilities will be available for public comment and review as from **Thursday 29 September 2016 to Monday 31 October 2016** (end of business day). Should you wish to receive an electronic copy of the DSRs (CD) please forward your request in writing to us. Hard copies of the DSRs can be reviewed at the following public place:

VENUE	STREET ADDRESS	HOURS	CONTACT NO
Lichtenburg Public Library	Nelson Mandela Drive, Lichtenburg	Mondays- Thursdays 09h00 – 17h30 Fridays 09h00 – 17h00 Saturdays 09h00 – 12h00	018 633 3904

The reports are also available on SIVEST's website: <http://www.sivest.co.za/>, then browse to the 'older' '13303 Tlisitseng PV Energy Development'.

To register as an Interested and / or Affected Party (I&AP) and / or to obtain additional information please submit your name, contact details and the interest which you have in the application within 30 days from the date of this notice. Please direct enquiries, in writing, to the Environmental Consultants below:

Andrea Gibb	
SIVEST Environmental P O Box 2921 RIVONIA 2128	Tel: (011) 798 0600 Fax: (011) 803 7272 E-mail: andreag@sivest.co.za Website: www.sivest.co.za

SIVEST
Omgewingsafdeling

SIVEST
Gestig in 1952

OMGEWINGSIMPAKEVALUERINGS (OIE's) VIR DIE BEOOGDE ONTWIKKELING VAN DIE TWEË (2) TLISITSENG 75 MW FOTOVOLTAÏESE (FV) SONKRAGAAANLEGTE EN BASIESE EVALUERINGS (BE'S) VIR DIE GEPAARDGAANDE 132 KV KRAGLYNE NABY LICHTENBURG, NOORDWES-PROVINSIE

Ingevolge die Nasionale Wet op Omgewingsbestuur, 1998 (Wet 107 van 1998) (NEMA), soos gewysig, en die Regulasies op Omgewingsimpekevaluering (OIE-regulasies) ingevolge Staatskenningsgewing R982, R983, R984 en R985 wat op 4 Desember 2014 ingevolge kennis hiermee dat BioTherm Energy (Edms.) Bpk. SIVEST SA (Edms.) Bpk. aangestel het as die onafhanklike omgewingsimpekevalueringsoptreksyn (OEP) ten einde die nodige OIE en openbare deelnameprosesse vir die bogenoemde voorgestelde projekte te onderneem:

PROJEKBESKRYWING

BioTherm Energy (Edms.) Bpk. (hierna BioTherm genoem) stel die oprigting voor twee (2) Tlisitseng fotovoltaïese (FV) sonkragaanlegte (hierna die "beoogde ontwikkeling" genoem) naby Lichtenburg, Noordwes-provinsie. Die beoogde ontwikkeling sal bestaan uit twee (2) FV-sonkragaanlegte van 75 MW elk wat as Tlisitseng 1 en Tlisitseng 2 sal bekendstaan. Daarbenewens beoog BioTherm die oprigting van twee 132 kV kraglyne ten einde die beoogde FV-sonkragaanlegte met die bestaande Watershed Hooftransmissie-substansie (HTS) te verbind. Die oorkoepende doelwit van die projek is om elektrisiteit op te wek om in die nasionale kraglyn te voer.

Derhalwe sal twee (2) OIE's onderneem word; een vir elk van die beoogde Tlisitseng FV-sonkragaanlegte. Daarbenewens sal twee (2) BE's onderneem word; een vir elk van die gepaardgaande 132 kV kraglyne. Hoewel elke FV-aanleg en die elektriese infrastruktuur apart geëvalueer sal word, word 'n enkele openbare deelnameproses vir al vier (4) beoogde projekte onderneem.

PROJEKLEGGING

Die beoogde projek is geleë in die Noordwes-provinsie, sowat 8 km noordwes van Lichtenburg. Dit is in die Ditsobotla Plaaslike Munisipaliteit geleë, wat deel vorm van die Ngaka Modiri Molema Distriksmunisipaliteit. Die projek sluit die volgende plekke in:

- Gedeelte 25 van die plaas Houthaalboom No. 31
- Restant van Gedeelte 1 van die plaas Lichtenburg Town and Townlands No. 27
- Gedeelte 10 van die plaas Lichtenburg Town and Townlands No. 27

UITNODIGING OM KOMENTAAR TE LEWER OP DIE KONSEP BESTEKOPNAMEVERSLAE

Die Konsep Bestekopnameverslae vir die beoogde ontwikkeling van die twee (2) Tlisitseng 75 MW FV sonkragaanlegte beskikbaar sal wees vir openbare kommentaar en oorsig vanaf **Donderdag 29 September 2016 tot Maandag 31 Oktober 2016** (teen sluitingstyd). Sou u graag 'n elektroniese kopie van die Konsep Bestekopnameverslae op CD wil ontvang, kan u dit skriftelik by ons aanvra. Gedrukte eksemplare van die Konsep Bestekopnameverslae sal ook by die volgende openbare plek beskikbaar wees vir besigtiging:

PLEK	STRAATADRES	KANTOOR URE	KONTAKNO.
Lichtenburg Openbare Biblioteek	Nelson Mandela Drive, Lichtenburg	Maandae- Donderdae 09h00 – 17h30 Vrydae 09h00 – 17h00 Saterdag 09h00 – 12h00	018 633 3904

Die Verslae is ook op SIVEST se webtuiste beskikbaar: <http://www.sivest.co.za/>, klik dan op die legger '13303 Tlisitseng PV Energy Development'.

Ten einde as 'n Belangstellende en/of Geaffekteerde Party (B&GP) te registreer en/of om meer inligting te bekom, moet u asseblief u naam, kontakbesonderhede en die belang wat u by die aansoek het binne 30 dae vanaf die datum van hierdie kennisgewing indien. Rig asseblief u skriftelike navrae aan die Omgewingskonsultante hieronder:

Andrea Gibb	
SIVEST Environmental Posbus 2921 RIVONIA 2128	Tel: 011 798 0600 Faks: 011 803 7272 E-pos: andreag@sivest.co.za Webwêrf: www.sivest.co.za



Appendix E2

PROOF OF WRITTEN NOTIFICATIONS

ENVIRONMENTAL IMPACT ASSESSMENTS (EIAs) FOR THE PROPOSED DEVELOPMENT OF THE TWO (2) TLI SITSENG 75MW SOLAR PHOTOVOLTAIC (PV) ENERGY FACILITIES AND BASIC ASSESSMENTS (BAs) FOR THE ASSOCIATED 132KV POWER LINES NEAR LICHTENBURG, NORTH WEST PROVINCE

Co-ordinates: 26° 8'50.75"S & 26° 9'36.51"E



Figure 1: Ditsobotla Public Library, Nelson Mandela Drive, Lichtenburg



Invitation to participate
letter & Registration
Forms

BIDs

Figure 2: Assistant Librarian, Ms Virginia Tau

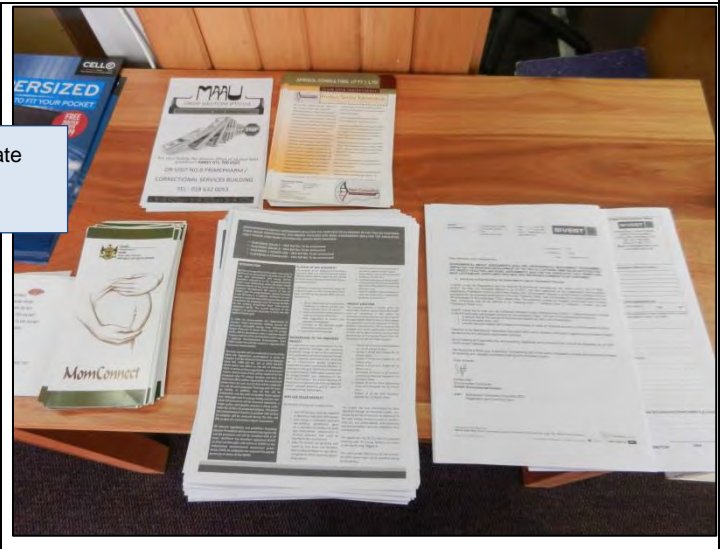

Figure 3: BIDs, Invitation letter to participate & Registration Forms in Library's foyer

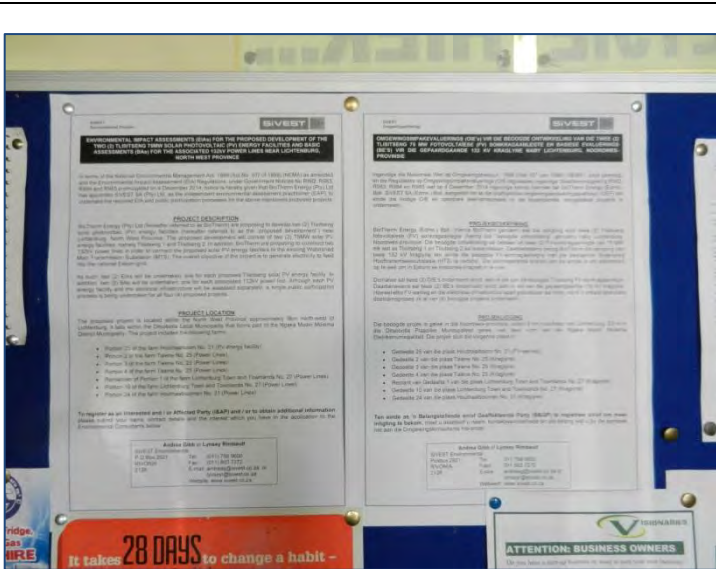

Figure 4: Ditsobotla Public Library Entrance Hall Notice Board

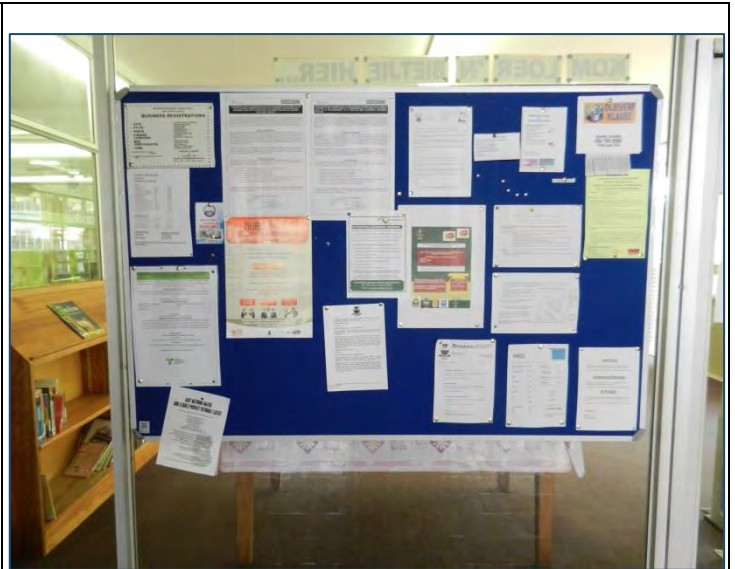

Figure 5: Ditsobotla Public Library Entrance Hall Notice Board



Figure 6: Ditsobotla Public Library Entrance Community Notice Board



Figure 7: Mr Thabelo Dikgang (Student & Blydeville Resident)

Co-ordinates: 26° 8'49.97"S & 26° 9'42.54"E



Figure 8: Ditsobotla Local Municipality (Account Payments)

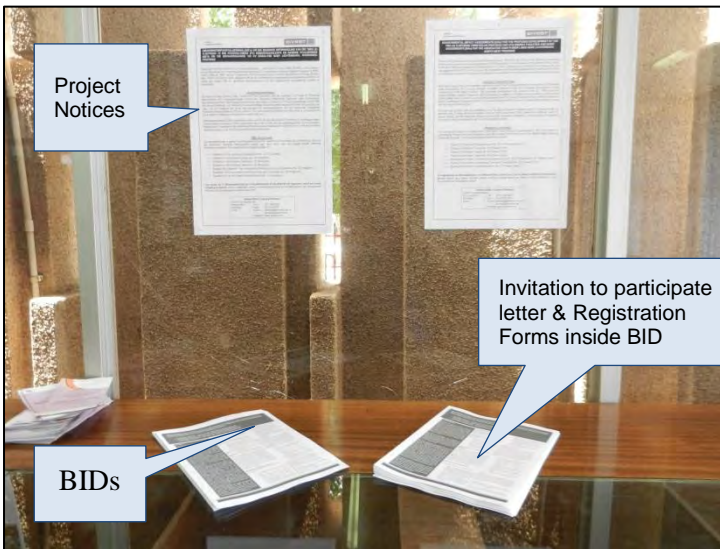

Figure 9: Account Payments Public Desk



Figure 10: Account Payments Public Desk

Andrea Gibb

From: sivest_PPP
Sent: Thursday, September 29, 2016 3:12 PM
Cc: Andrea Gibb
Subject: 13303 Revised Two Proposed Tlisitseng Solar Photovoltaic Energy Facilities
Attachments: 13303_Tlisitseng PV and Grid_ Invite Letter_Rev 1_28Sept2016_AG (Afrikaa....pdf; 13303_Tlisitseng PV and Grid_ Invite Letter_Rev 1_28Sept2016_AG.PDF; 13033 BID TLISITSENG (AFR).pdf; 13033 BID TLISITSENG.PDF; Tlisitseng Solar PV Plant DSR Comment Form rev 1 28Sept2016 AG - Combine....pdf; 13303_Lichtenburg Tlisitseng 1 PV_DSR Executive Summary_Ver 1_23Sep2016pdf; 13303_Lichtenburg Tlisitseng 1 PV_DSR Executive Summary_Ver 1_23Sep2016pdf; 13303_Lichtenburg Tlisitseng 2 PV_DSR Executive Summary_Ver 1_23Sep2016pdf; 13303_Lichtenburg Tlisitseng 2 PV_DSR Executive Summary_Ver 1_23Sep2016pdf

***** Please note that this email was sent from a NO REPLY email address. Please do not reply to this address as it is an unmonitored email account.*****

Dear Interested and/or Affected Party

ENVIRONMENTAL IMPACT ASSESSMENTS (EIAs) FOR THE PROPOSED CONSTRUCTION OF THE TWO (2) TLISITSENG 75MW SOLAR PHOTOVOLTAIC (PV) ENERGY FACILITIES, AND BASIC ASSESSMENTS (BAs) FOR THE ASSOCIATED 132kV POWER LINES NEAR LICHTENBURG, NORTH WEST PROVINCE (DEA REFERENCE NUMBERS TO BE CONFIRMED)

We would like to take this opportunity to inform you that in terms of the EIA Regulations, 2014 and the National Environmental Management Act, 1998 (Act No. 107 of 1998), SiVEST has been appointed as the independent Environmental Assessment Practitioner (EAP) by BioTherm Energy to re-conduct the EIA processes for the proposed development of the two (2) Tlisitseng 75MW solar photovoltaic (PV) energy facilities near Lichtenburg, North West Province. Due to a change in the layouts SiVEST was not able to submit the Final Environmental Impact Assessment Reports (FEIARs) within the legislated timeframes and therefore the applications for environmental authorisation (EA) lapsed in accordance with Regulation 45 of the EIA Regulations, 2014 and the departmental files were closed for the projects.

We would also like to inform you that the Draft Scoping Reports (DSRs) for the two (2) proposed Tlisitseng 75MW solar PV energy facilities will be available for public comment and review as from Thursday 29 September 2016 to Monday 31 October 2016 (end of business day).

Attached for your information is an English and Afrikaans Letter, Background Information Document (BID), Registration and Comment Form, as well as the DSR Executive Summaries for both proposed Tlisitseng 75MW solar PV energy facilities.

We would like to thank you, in advance, for becoming part of the public participation process and are looking forward to receiving your valuable comments relating to the proposed projects.

Yours sincerely

Andrea Gibb (B.Sc. Landscape Architecture; B.Sc.(Hons) Environmental Management) Environmental Practitioner and Visual Specialist SiVEST Environmental Division

SiVEST is a Level 3 BBBEE Contributor

Direct +27 11 798 0638 Tel +27 11 798 0600 fax +27 11 803 7272
email andreas@sivest.co.za website www.sivest.co.za

Consulting Engineers - Project Managers - Environmental Consultants - Town and Regional Planners
Durban - Johannesburg - Pietermaritzburg - Richards Bay - Ladysmith - Cape Town - Harare (Zimbabwe)

ENVIRONMENTAL IMPACT ASSESSMENTS (EIAs) FOR THE PROPOSED DEVELOPMENT OF THE TWO (2) TLISITSENG 75MW SOLAR PHOTOVOLTAIC (PV) ENERGY FACILITIES AND BASIC ASSESSMENTS (BAs) FOR THE ASSOCIATED 132kV POWER LINES NEAR LICHTENBURG, NORTH WEST PROVINCE

- TLISITSENG SOLAR 1 – DEA Ref No: To be announced
- TLISITSENG SOLAR 2 – DEA Ref No: To be announced
- TLISITSENG 1 POWER LINE – DEA Ref No: To be announced
- TLISITSENG 2 POWER LINE – DEA Ref No: To be announced

INTRODUCTION

BioTherm Energy (Pty) Ltd (hereafter referred to as BioTherm) are proposing to develop two (2) Tlisitseng solar photovoltaic (PV) energy facilities (hereafter referred to as the “proposed development”) near Lichtenburg within the Ngaka Modiri Molema District of the North West Province. The proposed development will consist of two (2) 75MW solar PV energy facilities, namely Tlisitseng 1 and Tlisitseng 2. In addition, BioTherm are proposing to construct two 132kV power lines in order to connect the proposed solar PV energy facilities to the existing Watershed Main Transmission substation (MTS). The overall objective of the project is to generate electricity to feed into the national Eskom grid.

Each PV energy facility will be developed under a separate Special Purpose Vehicle (SPV) and therefore each requires a separate Environmental Authorisation. Each 132kV power line will also require a separate Environmental Authorisation.

The EIAs and BAs will be conducted in terms of the 2014 EIA Regulations promulgated in terms of Chapter 5 of the National Environmental Management Act, 1998 (Act No. 107 of 1998) (NEMA), which came into effect on the 8th of December 2014. In terms of these regulations, Environmental Impact Assessments (EIAs) will be required for the proposed solar PV energy facilities and Basic Assessments (BAs) will be required for the associated power lines. As such, two (2) EIAs will be undertaken, one for each proposed Tlisitseng solar PV energy facility. In addition, two (2) BAs will be undertaken, one for each associated 132kV power line. Although each PV energy facility and the electrical infrastructure will be assessed separately, a single public participation process is being undertaken for all four (4) proposed projects. The potential environmental impacts associated with all four (4) projects will be assessed during the EIAs and BAs as part of a cumulative impact assessment.

All relevant legislations and guidelines (including Equator Principles) will be consulted during the EIA and BA processes and will be complied with at all times. BioTherm has therefore appointed SiVEST SA (Pty) Ltd (hereafter referred to as SiVEST) as the independent environmental assessment practitioner (EAP), to undertake the required EIA and BA processes in terms of the NEMA.

PURPOSE OF THIS DOCUMENT

The purpose of this Background Information Document (BID) is to inform Interested and/or Affected Parties (I&APs) about the EIA and BA processes that are being conducted for the proposed development.

In addition to supplying information about the proposed project and the environmental processes, this BID will also provide I&APs with the opportunity to:

- Better understand the proposed development in order to provide comments and raise issues of concern;
- Understand the EIA and BA process in order to participate effectively;
- Make suggestions to enhance the proposed development;
- Comment on the specialist studies that will be conducted; and
- Contribute local knowledge.

BACKGROUND TO THE PROPOSED PROJECT

In support of, the need to find solutions for the current electricity shortages, the increasing demand for energy, as well as the need to find more sustainable and environmentally friendly energy resources, South Africa has embarked on an infrastructure growth programme supported by various government initiatives. In response to this goal; BioTherm are proposing to establish two (2) 75MW export capacity solar PV energy facilities near Lichtenburg in the North West Province. The overall objective of the project is to generate electricity to feed into the national electricity grid by means of renewable energy technologies.

WHY USE SOLAR ENERGY?

The benefits of using solar energy include:

- Solar PV facilities have the capability of delivering large-scale utility power;
- Solar energy is renewable, clean and non-polluting (greenhouse gases etc.), and does not produce by-products (atmospheric contaminants or thermal pollution) that could be harmful to the environment;
- Solar PV facilities are generally well suited to rural areas and therefore

have a reduced impact on agriculture compared to other electricity generating options;

- Solar PV plants can also contribute to economic growth in these regions;
- Solar energy is one of the lowest-cost producers of electricity;
- Localised production of energy reduces transmission line losses associated with transmitting electricity over long distances; and
- Solar PV facilities improve energy security for South Africa, reducing dependency on fossil fuels.

PROJECT LOCATION

The proposed project is located within the North West Province approximately 8km north-west of Lichtenburg. It falls within the Ditsobotla Local Municipality that forms part of the Ngaka Modiri Molema District Municipality. The application site for the proposed PV energy facilities is approximately 1000 ha however the buildable area will be significantly smaller than this and will be determined by sensitive areas identified during the Scoping Phase of the EIA. The project includes the following farms:

- Portion 25 of the farm Houthaalboom No. 31 (PV energy facility)
- Remainder of Portion 1 of the farm Lichtenburg Town and Townlands No. 27 (Power Lines)
- Portion 10 of the farm Lichtenburg Town and Townlands No. 27 (Power Lines)

The project site near Lichtenburg has been identified through pre-feasibility studies conducted by BioTherm based on an estimation of the solar energy resource as well as weather, dust, dirt, and surface albedo. Grid connection and land availability were also important initial considerations.

The application site for the two (2) proposed Tlisitseng solar PV energy facilities are shown on the locality map (**Figure 1**).

The route corridor alternatives for the associated 132kV power lines will be provided during the BA process.

EIA/BA PROCESSES

What is an EIA?

An EIA is a process of collecting, organising, analysing, interpreting and communicating information that is relevant to consider a particular environmental application. EIAs are used by planning authorities/developers to obtain an independent and objective view of the potential environmental (biophysical and social) impacts that could arise during the construction and operation of the proposed development. This information needs to provide the Competent Authority with a sound basis for their decision-making.

What is a BA?

A BA is a similar process to an EIA, but is undertaken where the impacts are less likely to have significant impacts on the receiving environment. Like EIAs, BAs identify potential environmental impacts and provide the Competent Authority with a sound basis for their decision-making.

Legal requirements

According to the NEMA as amended, an EIA process is required for the proposed solar energy facilities as several listed notice 2 activities (GN R. 984) are triggered by each proposed project. A BA process is required for the associated power lines as several listed notice 1 activities (GN R. 983) are triggered by each proposed project.

The EIA and BA processes that will be followed are illustrated in Figure 2 and Figure 3 below.

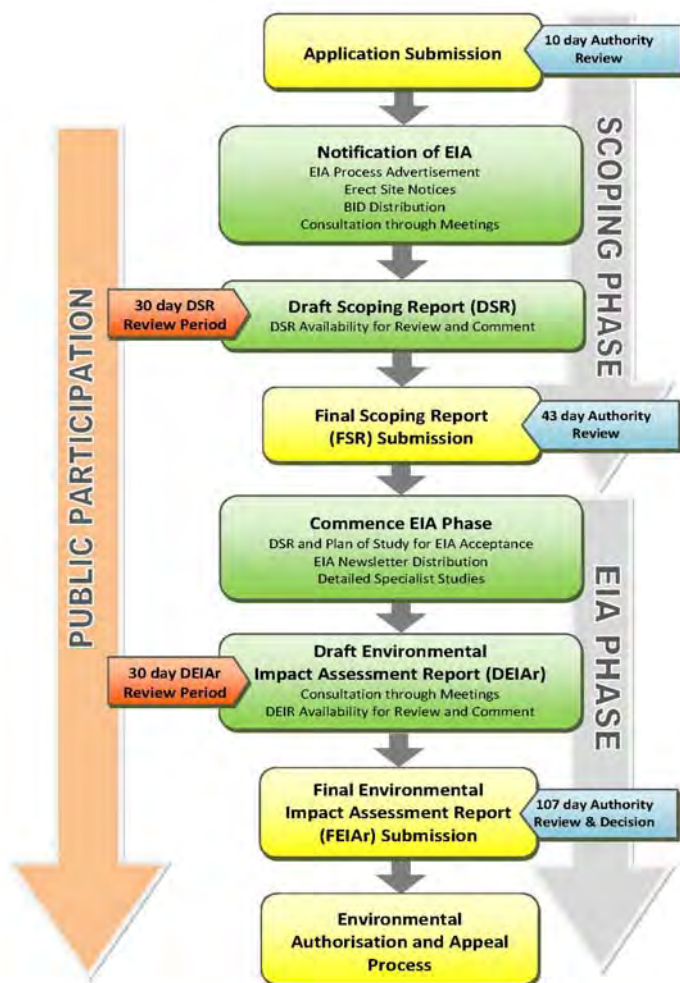

Figure 2: EIA process diagram

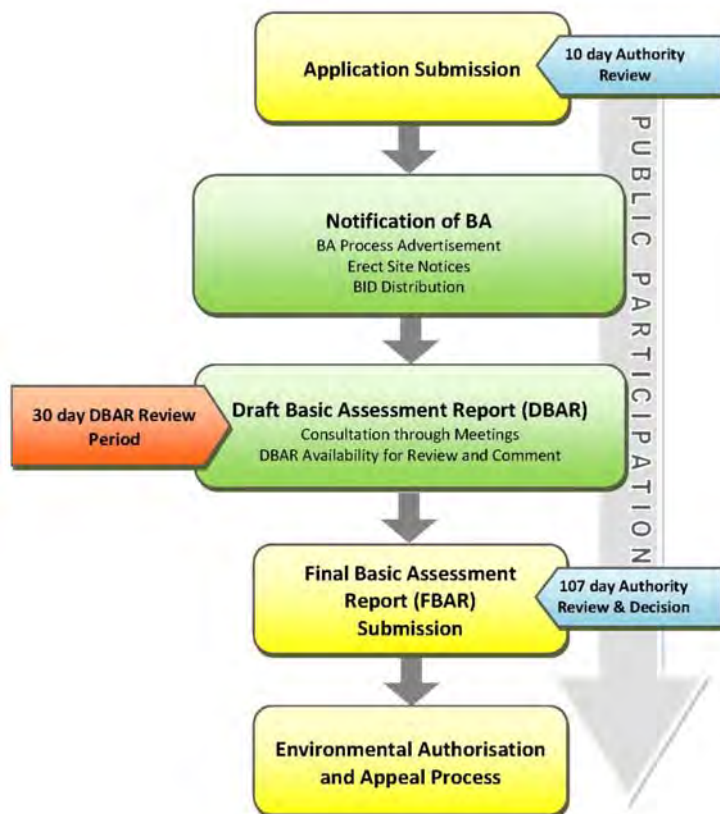

Figure 3: BA process diagram

Competent authority

The Competent Authority for this proposed projects is the DEA. However, the provincial authority will also be consulted (i.e. the North West Department of Rural, Environment and Agricultural Development).

Environmental issues to be investigated during the EIA and BA

Various environmental parameters have been identified that will require investigation for the proposed development. These are listed in Table 1 below.

Table 1. List of specialists and specialist studies to be undertaken for the proposed development

SKILL	NAME
Biodiversity	David Hoare Consulting – David Hoare
Avifauna	Chris van Rooyen Consulting – Chris van Rooyen
Surface Water	SiVEST – Shaun Taylor
Agricultural Potential and Soils	Agricultural Research Council (ARC): Institute for Soil, Climate and Water – Garry Paterson
Heritage and Palaeontology	PGS – Wouter Fourie, Jessica Angel
Visual	SiVEST – Andrea Gibb, Stephan Jacobs
Socio-Economic	Urban Econ – Elena Broughton
Traffic	Aurecon – Hermanus Steyn
Geotechnical	Geopractica – Colin Dalton, Thanduxolo Msen-gana
Public Participation	Zitholele Consulting - Nicolene Venter

THE PUBLIC PARTICIPATION PROCESS

Public participation is the cornerstone of any EIA or BA, as it will be for this proposed projects. The principles of NEMA govern many aspects of an EIA or BA, including public participation. The key objective of public participation during the EIA and BA will be to provide I&APs with sufficient and relevant information and to conduct a transparent consultation process on an on-going basis, in order to ensure effective participation throughout the

Figure 1: Locality Map

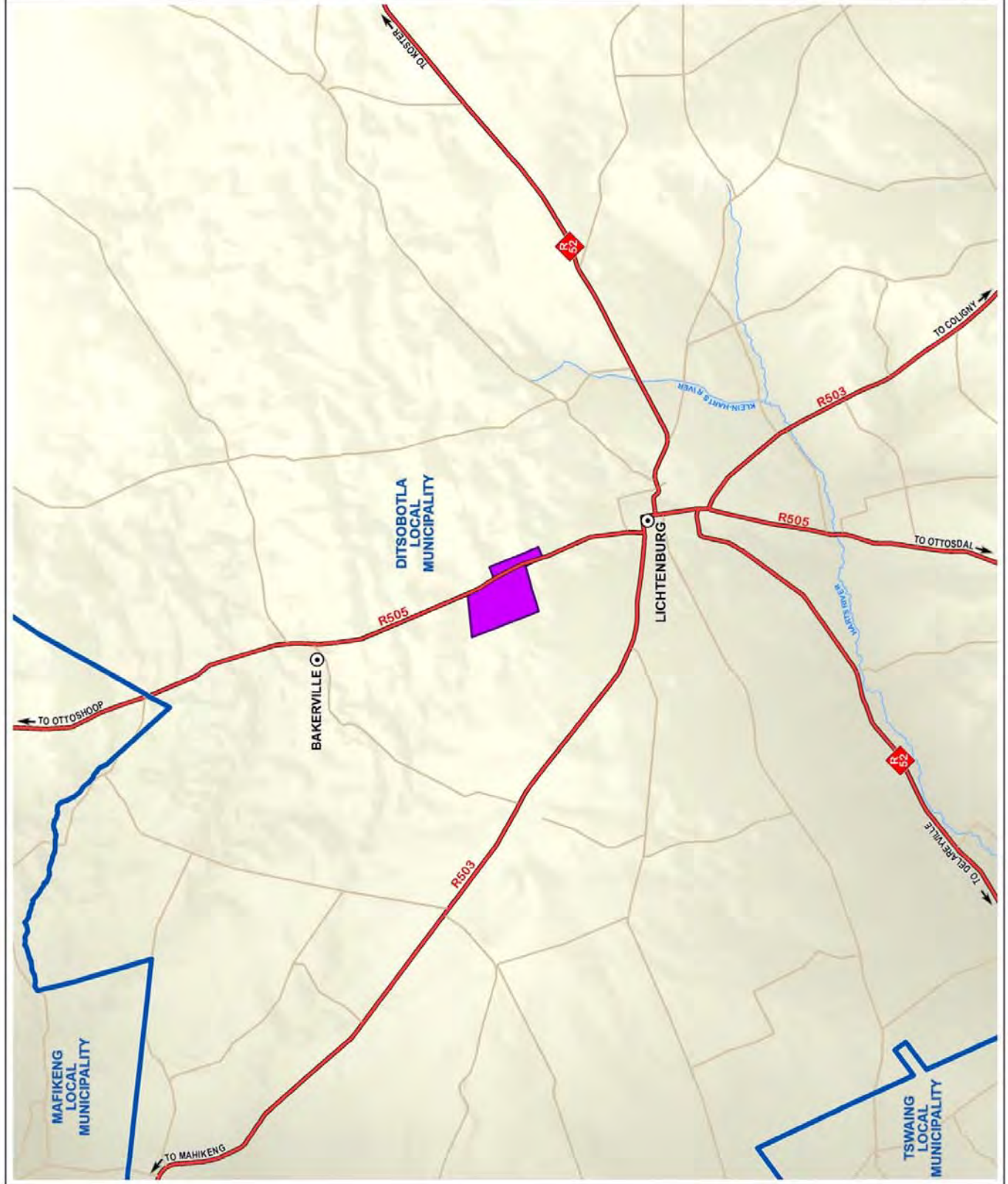
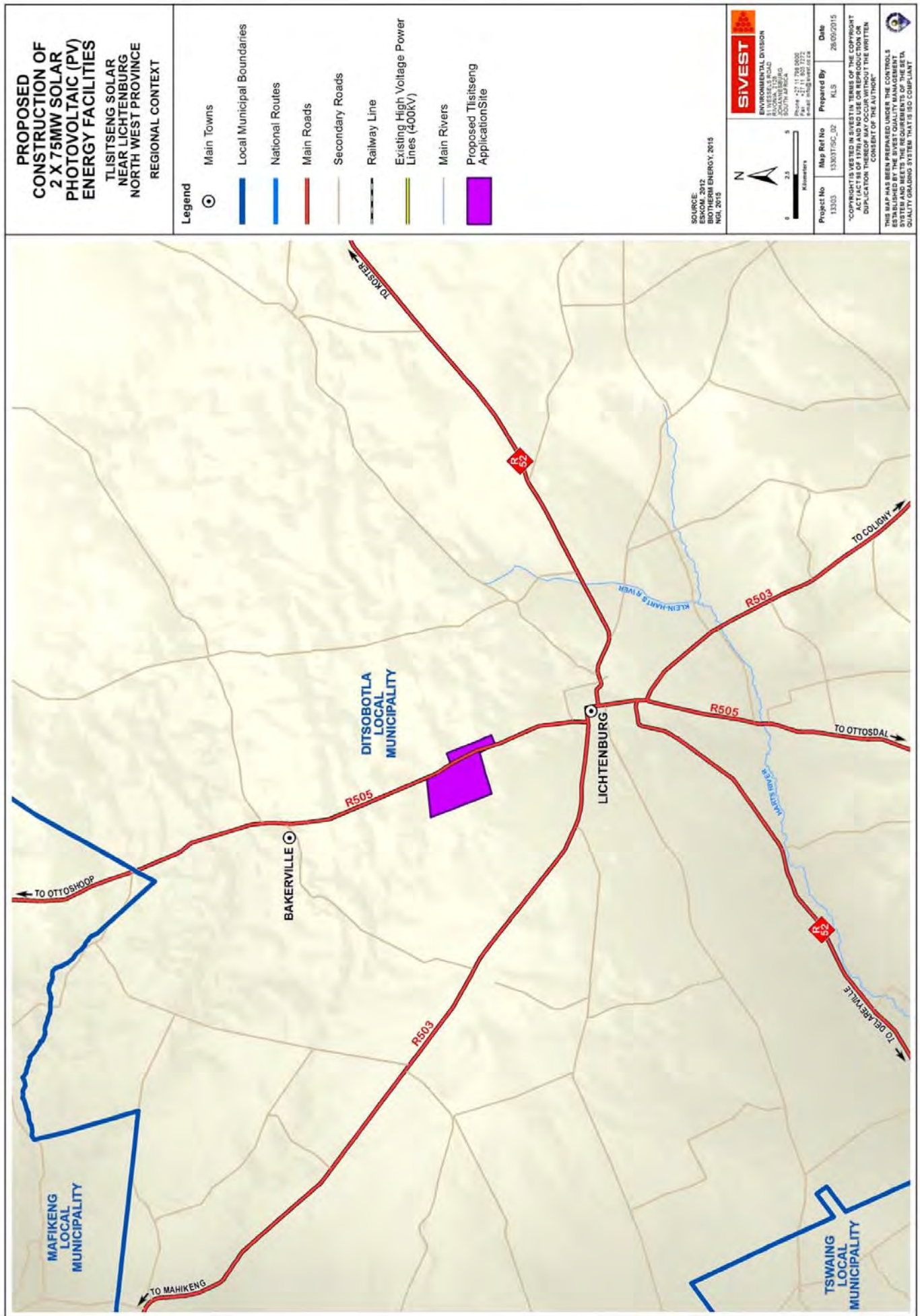

EIA and BA processes. As part of this public participation process you will also be provided with the opportunity to comment on the environmental findings as per the EIA and BA reports (Scoping, Impact Assessment and Basic Assessment), which will be made available for public review and comment during the processes.

It is important that relevant I&APs and Stakeholders are identified and involved in the public participation process from the outset of the proposed projects. As a registered I&AP, you will receive personal notifications, via e-mail, post, fax, and/or sms (where applicable), notifying you of all documents available for comment, the comment periods and the upcoming meetings.

Your responsibilities as an I&AP

In terms of the EIA Regulations, your attention is drawn to your responsibilities as an I&AP, which are to:

- Participate in the EIA and BA processes, register yourself on the project database;
- Inform any other parties (neighbours, friends, colleagues, etc.) who may be interested and/or affected by the proposed project about the EIA and BA processes and encourage them to become involved; and
- Ensure that any comments regarding the proposed projects are submitted within the legislated timeframes which will be communicated to you.

Our responsibilities as the independent EAP

In terms of the EIA Regulations, our responsibilities in the public consultation process include:

- Ensuring that sufficient information regarding the proposed project is made available to you, either through the BID or providing information as and when requested;
- Ensuring that you have an understanding of the proposed project to be able to comment informatively, and to enable you to submit any concern in an informed manner; and

- Ensuring that the following actions are taken upon receiving any comments/queries/issues:
 - The contact details provided by you will be entered into the project database;
 - You will be sent all further information releases; and
 - If you send us queries or comments, we will respond in writing (either via e-mail or within the comments and response report).

How to become involved

If you wish to register as an I&AP, you can do so by the following methods:

- Respond (by phone, fax, post or e-mail) to our invitation for your participation, which has been advertised in the printed media;
- Post, fax or e-mail the attached Registration and Comment Form to SiVEST;
- Contact us telephonically should you have a query, comment or require further project information; and
- Submit comments on the draft Scoping Report (DSR) and/or the draft Environmental Impact Assessment Report (DEIAR) and/or the draft Basic Assessment Report within the review periods that will be stipulated.

If you consider yourself an I&AP for these proposed projects, we urge you to make use of the opportunities created by the public participation process to become actively involved in the process and provide comment or concerns which affect and/or interest you, or about which you would like more information. Your input into this process forms a key part of the environmental studies and we would like to hear from you to obtain your views on the proposed project.

By completing and submitting the accompanying Registration and Comment Form, you automatically register yourself as an I&AP for this proposed projects, ensuring that your comments and/or concerns raised regarding will be noted and addressed. The environmental consultants will respond to all comments and queries received during the course of the EIA or BA.

Please be informed that all relevant public documents can be downloaded from the SiVEST's website



We look forward to your contributions

Contact: Andrea Gibb  **PO Box 2921, RIVONIA, 2128**

 **Phone: (011) 798 0600**

 **E-mail: andrea@sivest.co.za**

 **Fax: (011) 803 7272**

Websites: www.sivest.co.za

LIST OF ACRONYMS

BA	Basic Assessment
BID	Background Information Document
DBAR	Draft Basic Assessment Report
DEA	Department of Environmental Affairs
DEIAR	Draft Environmental Impact Report
DSR	Draft Scoping Report
EAP	Environmental Assessment Practitioner
EMPr	Environmental Management Programme
EIA	Environmental Impact Assessment
FBAR	Final Basic Assessment Report
FEIAR	Final Environmental Impact Report
Ha	Hectares
I&AP	Interested and/or Affected Party
Km	Kilometre
kV	Kilovolt

OMGEWINGSIMPAKEVALUERINGS (OIE's) VIR DIE BEOOGDE ONTWIKKELING VAN DIE TWEE (2) TLISITSENG 75 MW FOTOVOLTAÏESE (FV) SONKRAGANLEGTE EN BASIESE EVALUERINGS (BE'S) VIR DIE GEPAARDGAANDE 132 KV KRAGLYNE NABY LICHTENBURG, NOORDWES-PROVINSIE

- TLISITSENG SOLAR 1 – DO Verw. No.: Moet nog aangekondig word
- TLISITSENG SOLAR 2 – DO Verw. No.: Moet nog aangekondig word
- TLISITSENG 1 KRAGLYN – DO Verw. No.: Moet nog aangekondig word
- TLISITSENG 2 KRAGLYN – DO Verw. No.: Moet nog aangekondig word

INLEIDING

BioTherm Energy (Edms.) Bpk. (hierna BioTherm genoem) stel die oprigting voor twee (2) Tlisitseng fotovoltaiëse (FV) sonkragaanlegte (hierna die “beoogde ontwikkeling” genoem) naby Lichtenburg in die Ngaka Modiri Molema Distriksmunisipaliteit van die Noordwes-provinsie. Die beoogde ontwikkeling sal bestaan uit twee (2) FV-sonkragaanlegte van 75 MW elk wat as Tlisitseng 1 en Tlisitseng 2 sal bekendstaan. Daarbenewens beoog BioTherm die oprigting van twee 132 kV kraglyne ten einde die beoogde FV-sonkragaanlegte met die bestaande Watershed Hooftransmissiesubstasie (HTS) te verbind. Die oorkoepelende doelwit van die projek is om elektrisiteit op te wek om in Eskom se nasionale kragnet in te voer.

Elke FV-aanleg sal onder 'n aparte Spesiale-doelmedium (SDM) ontwikkel word, derhalwe vereis elke aanleg 'n aparte Omgewingsmagtiging. Elke 132 kV kraglyn sal ook 'n aparte Omgewingsmagtiging verg.

Die OIE's en BE's sal ingevolge die 2014 OIE-regulasies onderneem word wat kragtens Artikel 5 van die Nasionale Wet op Omgewingsbestuur, 1998 (Wet 107 van 1998) (NEMA) afgekondig is, wat op 8 Desember 2014 in werking getree het. Ingevolge hierdie regulasies sal Omgewingsimpakevaluerings (OIE's) vir die beoogde FV-sonkragaanlegte vereis word en Basiese Evaluering (BE's) sal vir die gepaardgaande kraglyne vereis word. Derhalwe sal twee (2) OIE's onderneem word; een vir elk van die beoogde Tlisitseng FV-sonkragaanlegte. Daarbenewens sal twee (2) BE's onderneem word; een vir elk van die gepaardgaande 132 kV kraglyne. Hoewel elke FV-aanleg en die elektriese infrastruktuur apart geëvalueer sal word, word 'n enkele openbare deelnameproses vir al vier (4) beoogde projekte onderneem. Die potensiele omgewingsimpakte wat verband hou met al vier (4) projekte sal tydens die OIE's en BE's as deel van 'n kumulatiewe impakevaluering geëvalueer word.

Alle tersaaklike wetgewing en riglyne (insluitend die Ekwatorbeginsels) sal tydens die OIE- en BE-proses geraadpleeg en ten alle tye aan voldoen word. BioTherm het SiVEST SA (Edms.) Bpk. (hierna SiVEST genoem) derhalwe as die onafhanklike omgewingsevalueringpraktisyn (OEP) aangestel om die nodige OIE- en BE-proses ingevolge die NEMA te onderneem.

DOEL VAN HIERDIE DOKUMENT

Die doel van hierdie Agtergrondinligtingsdokument (AID) is om Belangstellende en/of Geaffekteerde Partye (B&GP's) in te lig oor die OIE- en BE-proses wat vir die beoogde ontwikkeling onderneem word.

Benewens die verskaffing van inligting oor die beoogde projek en die omgewingsprosesse, sal hierdie AID ook aan B&GP's die geleentheid bied om:

- die beoogde ontwikkeling beter te verstaan ten einde kommentaar te lewer en knelpunte te opper;
- die OIE- en BE-proses te verstaan ten einde doeltreffend daaraan te kan deelneem;
- voorstelle te maak om die beoogde ontwikkeling te verbeter;

kommentaar te lewer oor die spesialisstudies wat onderneem gaan word; en

- plaaslike kennis by te dra.

AGTERGROND TOT DIE BEOOGDE PROJEK

Ter ondersteuning van die behoefte om oplossings te vind vir die huidige elektrisiteitstekorte, die groter vraag na elektrisiteit en ook die behoefte om meer volhoubare en omgewingsvriendelike kraghulpbronne te vind, het Suid-Afrika 'n infrastruktuur-groeiprogram aangepak wat deur verskeie staatsinisiatiewe ondersteun word. In antwoord op hierdie doelwit, doen BioTherm aan die hand om twee (2) 75 MW FV-sonkragaanlegte, elk met 'n uitvoervermoë van 75 MW, naby Lichtenburg in die Noordwes-provinsie op te rig. Die oorkoepelende doelwit van die projek is om elektrisiteit op te wek om in die nasionale kragrooster in te voer aan die hand van hernubare kragtegnologieë.

WAAROM SONKRAG GEBRUIK?

Die voordele van die benutting van sonkrag sluit die volgende in:

- FV-sonkragaanlegte het die vermoë om grootskaal kommersiële krag te lewer.
- Sonkrag is hernubbaar, skoon en nie-besoedelend (kweekhuisgasse, ens.) en lewer geen nuwe produkte (atmosferiese besoedelaars of termiese besoedeling) op wat skadelik vir die omgewing kan wees nie.

- FV-sonkragaanlegte is oor die algemeen baie gepas vir plattelandse omgewings en derhalwe het dit 'n kleiner impak op landbou in vergelyking met ander kragopwekkingsopsies.
- FV-sonkragaanlegte kan ook bydra tot ekonomiese groei in hierdie gebiede.
- Sonkrag is een van die goedkoopste maniere om elektrisiteit op te wek.
- Plaaslike kragproduksie verminder verliese deur transmissielyn wat gepaardgaan met die oorbring van elektrisiteit oor lang afstande.
- FV-sonkragaanlegte verbeter Suid-Afrika se kragsekerheid, wat sodoende afhanklikheid van fossielbrandstowwe verminder.

PROJEKLIIGING

Die beoogde projek is geleë in die Noordwes-provinsie, sowat 8 km noordwes van Lichtenburg. Dit is in die Ditsobotla Plaaslike Munisipaliteit geleë, wat deel vorm van die Ngaka Modiri Molema Distriksmunisipaliteit. Die aansoekterrein vir die beoogde FV-kragaanlegte beslaan sowat 1 000 ha, hoewel die beboubare gebied wesenlik kleiner as dit sal wees en deur sensitiwe gebiede bepaal sal word wat tydens die Bestekopnamefase en die OIE geïdentifiseer sal word. Die projek sluit die volgende fase in:

- Gedeelte 25 van die plaas Houthaalboom No. 31 (FV-aanleg)
- Restant van Gedeelte 1 van die plaas Lichtenburg Town and Townlands No. 27 (Kraglyne)
- Gedeelte 10 van die plaas Lichtenburg Town and Townlands No. 27 (Kraglyne)

Die projekterrein naby Lichtenburg is geïdentifiseer deur vooraf-bedryfbaarheidstudies wat BioTherm op grond van 'n beraming van die sonkraghulpbron asook die weer, stof, grond en oppervlakkalbedo onderneem het. 'n Roosterkonneksie en die beskikbaarheid van grond was ook aanvanklik belangrike oorwegings.

Die aansoekterrein vir die twee (2) beoogde Tlisitseng FV-sonkragaanlegte word op die ligingskaart aangedui (**Figuur 1**).

Die alternatiewe roetekorridors vir die gepaardgaande 132 kV kraglyne sal tydens die BE-proses voorsien word.

OIE-/BE-PROSES

Wat is 'n OIE?

'n OIE is 'n proses waardeur inligting wat tersaaklik is vir die oorweging van 'n betrokke omgewingsaansoek versamel, georganiseer, ontleed, vertolk en gekommunikeer word. OIE's word deur beplanningsowerhede/ ontwikkelers gebruik om 'n onafhanklike en objektiewe siening van die potensiële omgewingsimpakte (biofisies en maatskaplik) te verkry wat tydens die oprigting en bedryf van die beoogde ontwikkeling kan opduik. Hierdie inligting moet die Bevoegde Owerheid 'n konkrete grondslag vir hul besluitneming bied.

Wat is 'n BE?

'n BE is 'n proses soortgelyk aan 'n OIE, maar word onderneem wanneer die impakte minder waarskynlik 'n wesentliche impak op die ontvangsomgewing sal hê. Net soos OIE's, identifiseer BE's ook potensiële omgewingsimpakte en bied aan die Bevoegde Owerheid 'n konkrete grondslag vir hul besluitneming.

Wetlike vereistes

Kragtens NEMA, soos gewysig, moet 'n OIE-proses vir die beoogde sonkraanlegte onderneem word aangesien elk van die beoogde projekte aanleiding gee tot verskeie gelyste kennisgewing 2-aktiwiteite (Staatskennisgewing R984). 'n BE-proses word vir die gepaardgaande kraglyne vereis aangesien elk van die beoogde projekte aanleiding gee tot verskeie gelyste kennisgewing 1-aktiwiteite (Staatskennisgewing R983).

Die OIE- en BE-proses wat gevolg sal word, word in Figuur 2 en Figuur 3 hieronder uiteengesit.

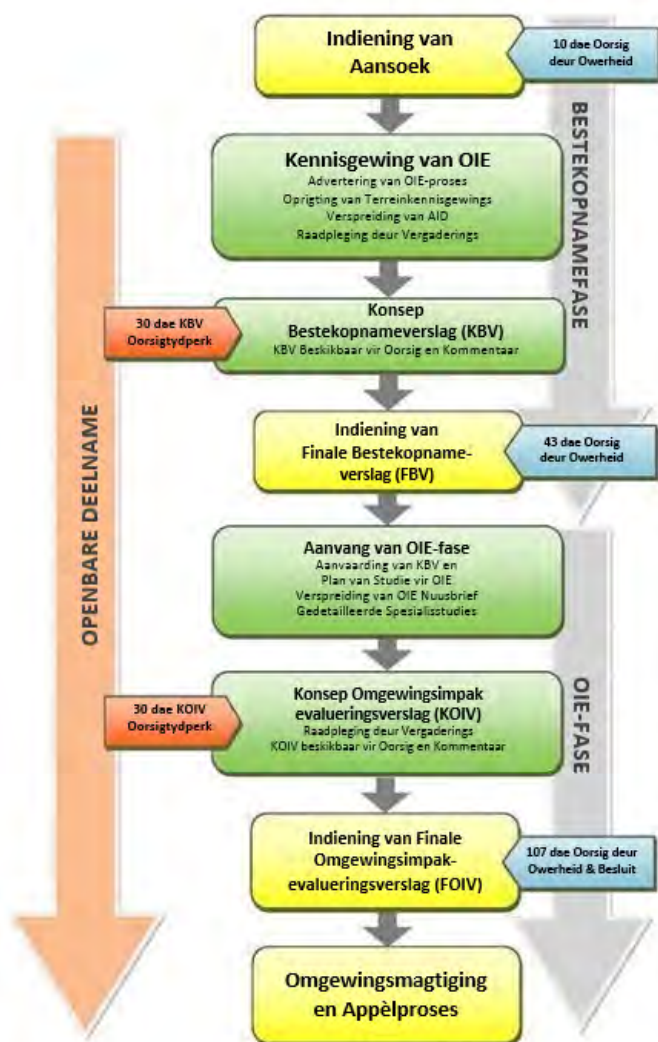

Figuur 2: Diagram van OIE-proses

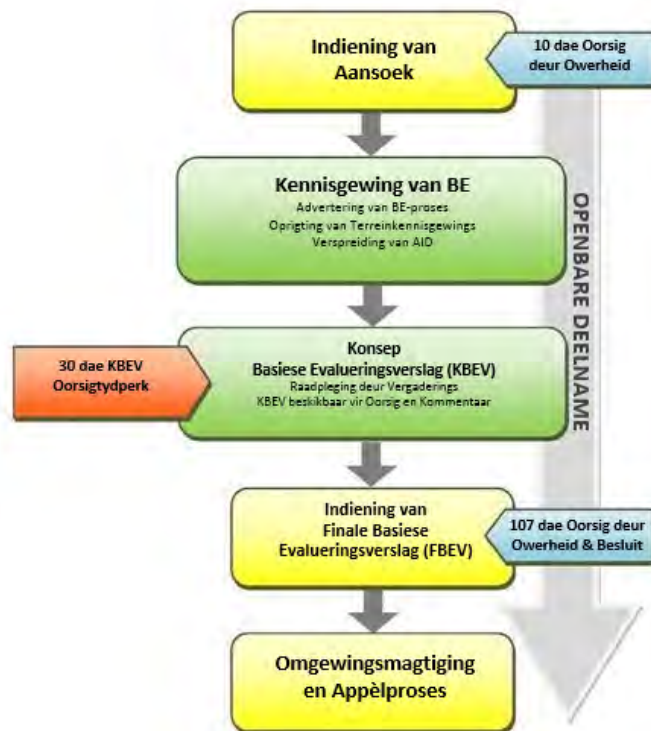

Figuur 3: Diagram van BE-proses

Bevoegde Owerheid

Die DO is die Bevoegde Owerheid vir hierdie beoogde projekte. Die provinsiale owerheid (d.i. die Noordwes Departement van Landelike, Omgewings- en Landbou-ontwikkeling) sal egter ook geraadpleeg word.

Omgewingsvraagstukke wat tydens die OIE en BE ondersoek gaan word. Verskeie omgewingsparameters is geïdentifiseer, wat vir die beoogde ontwikkeling ondersoek sal moet word. Dit word in Tabel 1 hieronder gelys.

Tabel 1. Lys van spesialiste en spesialisstudies wat vir die beoogde ontwikkeling onderneem word.

VAARDIGHEID	NAAM
Biodiversiteit	David Hoare Consulting – David Hoare
Avifauna	Chris van Rooyen Consulting – Chris van Rooyen
Oppervlaktwater	SiVEST – Shaun Taylor
Landboupotensiaal en Grondsoorte	Landbounavorsingsraad (LNR): Instituut vir Grond, Klimaat en Water – Garry Paterson
Erfenis en Paleontologie	PGS – Wouter Fourie, Jessica Angel
Visueel	SiVEST – Andrea Gibb, Stephan Jacobs
Sosio-ekonomies	Urban Econ – Elena Broughton
Verkeer	Aurecon – Hermanus Steyn
Geotegniese	Geopractica – Colin Dalton, Thanduxolo Msen-gana
Openbare Deelname	Zitholele Consulting – Nicolene Venter

DIE OPENBARE DEELNAMEPROSES

Openbare deelname is die hoeksteen van enige OIE of BE, soos ook die geval is vir hierdie beoogde projekte. Die beginsels van NEMA beheer baie aspekte van 'n OIE of BE, insluitend openbare deelname. Die primêre doelwit van openbare deelname gedurende die OIE en BE sal wees om B&GP's te voorsien van genoegsame en tersaaklike inligting en om 'n volgehoue, deursigtige oorlegplegingsproses te onderneem ten einde doeltreffende deelname regdeur die OIE- en BE-proses te verseker. As deel van hierdie openbare deelnameproses sal u ook die geleentheid gebied word om kommentaar te lewer oor die omgewingsbevindinge van die OIE-verslae (Bestekopname, Impakevaluering en Basiese Evaluering) wat tydens die prosesse vir openbare oorsig en kommentaar beskikbaar gestel sal word.

Dit is belangrik dat tersaaklike B&GP's en Belanghebbendes uit die staanspoor van die beoogde projekte geïdentifiseer en by die openbare deelnameproses betrek word. As 'n geregistreeerde B&GP sal u persoonlike kennisgewings per e-pos, pos, faks en/of sms (waar van toepassing) ontvang, wat u in kennis sal stel van alle dokumente wat beskikbaar is vir kommentaar, wat die kommentaartydperke is en van vergaderings wat binnekort gehou gaan word.

U verantwoordelikhede as 'n B&GP

Kragtens die OIE-regulasies, word u aandag gevestig op u verantwoordelikhede as 'n B&GP, naamlik:

- Deel neem aan die OIE- en BE-proses; registreer self op die projek se databasis.
- Stel alle ander partye (bure, vriende, kollegas, ens.) wat kan belangstel in en/of geaffekteer word deur die beoogde projek in kennis van die OIE- en BE-proses en moedig hulle aan om betrokke te raak.
- Sien toe dat enige kommentaar rakende die beoogde projekte binne die wetlike spertye ingedien word wat aan u gekommunikeer is.

Ons verantwoordelikhede as die Onafhanklike OEP

Ingevolge die OIE-regulasies, sluit ons verantwoordelikhede in die openbare deelnameproses die volgende in:

- Sien toe dat B&GP's genoegsame inligting betreffende die beoogde projek ontvang, hetsy deur die AID of deur inligting te verskaf soos en wanneer dit versoek word.
- Sorg dat B&GP's van 'n voldoende begrip van die beoogde projek verskaf word sodat hulle in staat is om betekenisvolle en ingeligte kommentaar te lewer en knelpunte te opper.
- Sien toe dat die volgende aksies met ontvangs van enige kommentaar/navraag/vraagstuk geneem word:
 - ♦ Die kontakbesonderhede wat u verskaf het sal in die projekdatabasis ingevoer word.
 - ♦ U sal alle toekomstige bekendmakings van inligting ontvang.

- ♦ Indien u navrae of kommentaar aan ons rig, sal ons reageer (hetsy per e-pos of in die kommentaar- en antwoordverslag).

Hoe om betrokke te raak

Indien u as 'n B&GP wil registreer, kan u dit aan die hand van die volgende metodes doen:

- Reageer (per telefoon, faks, pos of e-pos) op ons uitnodiging vir u deelname, wat in die gedrukte media geadverteer is.
- Pos, faks of e-pos die aangehegte Registrasie- en Kommentaarvorm aan SiVEST.
- Tree telefonies met ons in verbinding indien u 'n navraag of kommentaar het of verdere projekinligting verlang.
- Lewer kommentaar op die Konsep Bestekopnameverslag (KBEV) en/of die Konsep Omgewingsimpakevalueringverslag (KOIV) en/of die Konsep Basiese Evalueringverslag binne die oorsigtydperke wat bekendgemaak sal word.

Indien u self as 'n B&GP vir hierdie beoogde projekte ag, moedig ons u aan om gebruik te maak van die geleentheid wat deur die openbare deelnameproses geskep word om aktief by die proses betrokke te raak en kommentaar te lewer of daardie vraagstukke of knelpunte te opper wat u raak en/of waarin u belangstel of waaroor u meer inligting verlang. U insette in hierdie proses vorm 'n belangrike deel van die omgewingstudies en ons hoor graag van u om u siening oor die beoogde projek te bekom.

Deur die meegaande Registrasie en Kommentaarvorm in te vul en in te dien, registreer u self outomaties as 'n B&GP vir hierdie beoogde projekte en verseker u dat kennis geneem word van die kommentaar en/of knelpunte wat u opper. Die omgewingskonsultante sal op alle kommentaar en navrae reageer wat tydens die verloop van die OIE of BE ontvang word.

Let asseblief daarop dat alle tersaaklike publieke dokumente van SiVEST se webwerf afgelaai kan word.



Ons sien uit na u bydraes

Kontak: Andrea Gibb

Posbus 2921, RIVONIA, 2128

Tel: 011 798 0600

E-pos: andreaq@sivest.co.za

Faks: 011 803 7272

Webwerf: www.sivest.co.za

LYS VAN AKRONIEME

AID	Agtergrondinligtingsdokument
B&GP	Belangstellende en/of Geaffekteerde Party
BE	Basiese Evaluering
DO	Departement van Omgewingsake
FBEV	Finale Basiese Evalueringverslag
FOIV	Finale Omgewingsimpakverslag
FV	Fotovoltaïes
Ha	Hektaar
KBEV	Konsep Basiese Evalueringverslag
KBV	Konsep Bestekopnameverslag
Km	kilometer
KOIV	Konsep Omgewingsimpakverslag
kV	Kilovolt
MW	Megawatt
NEMA	Nasionale Wet op Omgewingsbestuur, 1998 (Wet 107 van 1998)
OBPr	Omgewingsbestuursprogram
OEP	Omgewingsevalueringpraktisyn
OIE	Omgewingsimpakevaluering

Your reference N/A
Our reference 13303 - Tlisitseng
Date 29 September 2016

Dear Interested and/or Affected Party

ENVIRONMENTAL IMPACT ASSESSMENTS (EIAs) FOR THE PROPOSED CONSTRUCTION OF THE TWO (2) TLISITSENG 75MW SOLAR PHOTOVOLTAIC (PV) ENERGY FACILITIES, AND BASIC ASSESSMENTS (BAs) FOR THE ASSOCIATED 132kV POWER LINES NEAR LICHTENBURG, NORTH WEST PROVINCE (DEA REFERENCE NUMBERS TO BE CONFIRMED)

- **INVITATION TO PARTICIPATE IN THE EIA AND BA PROCESSES**
- **AVAILABILITY OF DRAFT SCOPING REPORTS FOR PUBLIC REVIEW**

In terms of the EIA Regulations, 2014 and the National Environmental Management Act, 1998 (Act No. 107 of 1998), SiVEST SA (Pty) Ltd (hereafter referred to as SiVEST) has been appointed as the independent Environmental Assessment Practitioner (EAP) by BioTherm Energy (Pty) Ltd (hereafter referred to as BioTherm) to conduct the EIA processes for the proposed development of the two Tlisitseng 75MW solar photovoltaic (PV) energy facilities and the BA processes for the associated 132kV power lines. The proposed projects are located in the North West Province near Lichtenburg and will be referred to as Tlisitseng 1 Solar, Tlisitseng 2 Solar, Tlisitseng 1 Power Line, and Tlisitseng 2 Power Line.

SiVEST would like to invite you, as a potential Interested and/or Affected Party (I&AP), to become actively involved in the public participation process for this proposed projects. The aim of this process is as follows:

- to ensure that all the relevant environmental impacts are taken into consideration;
- to ensure public input; and
- provide decision-makers with sufficient information to make an informed decision on the proposed activities.

Attached is the Background Information Document (BID) which contains information regarding the proposed project as well as the EIA, BA and public participation process.

The Draft Scoping Reports (DSRs) for the proposed development of the two (2) proposed Tlisitseng 75MW solar PV energy facilities will also be available for public comment and review as from **Thursday 29 September 2016 to Monday 31 October 2016** (end of business day). Should you wish to receive an electronic copy of the DSRs (CD) please forward your request in writing to us. Hard copies of the DSRs can be reviewed at the following public place:

VENUE	STREET ADDRESS	HOURS	CONTACT NO
Lichtenburg Public Library	Nelson Mandela Drive, Lichtenburg	Mondays- Thursdays 09h00 – 17h30 Fridays 09h00 – 17h00 Saturdays 09h00 – 12h00	018 633 3904

The reports are also available on SiVEST's website: <http://www.sivest.co.za/>, then browse to the folder '13303 Tlisitseng PV Energy Development'.

It is important to note that these DSRs are the second versions which will be submitted to the DEA and made available for public comment. On the 18th of January 2016 applications for environmental authorisation (EA) and the

DSRs for the two (2) proposed Tlisitseng 75MW solar PV energy facilities were received by the DEA and reference numbers were allocated to the proposed development (**DEA reference number: 14/12/16/3/3/2/889 and 14/12/16/3/3/2/890**). These original DSRs were made available for public review from the 11th of January 2016 to the 9th of February 2016. The DSRs were thereafter updated and the Final Scoping Reports (FSRs) were submitted to the DEA on the 19th of February 2016. After evaluating the FSRs the DEA issued letters indicating that the documents complied with the minimum requirements of the EIA Regulations, 2014 and that SiVEST could proceed with the EIA processes. The original FSRs were therefore accepted by the DEA. It should however be noted that due to a change in the layout of the two (2) proposed Tlisitseng 75MW solar PV energy facilities, SiVEST was not able to submit the Final Environmental Impact Assessment Reports (FEIARs) within the legislated timeframes. On the 20th of June 2016, SiVEST sent the DEA a letter requesting a sixty (60) day extension in terms of Regulation 3 (7) of the EIA Regulations, 2014, in order to provide the specialists with the opportunity to update their specialist reports in-line with the revised layouts. On the 20th of July 2016, the DEA issued a letter refusing the extension request. For this reason the applications for EA lapsed in accordance with Regulation 45 of the EIA Regulations, 2014 and the departmental files were closed for the project.

In order to reapply for EA for the two (2) proposed Tlisitseng 75MW solar PV energy facilities, BioTherm has appointed SiVEST to recommence with the EIA and BA processes. It should however be noted that all comments received by Interested and Affected Parties (I&APs) during the Public Participation Process (PPP) which was undertaken for the original EIA processes (including those received during meetings) will form part of this EIA process. The public participation process will be re-conducted in accordance with the EIA Regulations, 2014 and all I&APs, Stakeholders and Organs of State will be afforded an extra opportunity to review the DSRs and to provide comments.

By completing and submitting the accompanying registration and comment form, you will be registered as an I&AP on the project database.

We would like to thank you, in advance, for becoming part of the public participation process and are looking forward to receiving your valuable comments relating to the proposed project.

Yours sincerely

A handwritten signature in black ink, appearing to read "Andrea Gibb".

Andrea Gibb
Environmental Practitioner
SiVEST Environmental Division

encl: Background Information Document (BID)
Registration and Comment Form
DSR Executive Summaries

U verwysing N.V.T.
Ons verwysing 13303 – Tlisitseng
Datum 29 September 2016

Geagte Belangstellende en/of Geaffekteerde Party

OMGEWINGSIMPAKEVALUERINGS (OIE's) VIR DIE BEOOGDE OPRIGTING VAN DIE TWEE (2) TLISITSENG 75 MW FOTOVOLTAÏESE (FV) SONKRAGAAANLEGTE EN BASIESE EVALUERINGS (BE's) VIR DIE GEPAARDGAANDE 132 KV KRAGLYNE NABY LICHTENBURG, NOORDWES-PROVINSIE (DO-VERWYSINGSNOMMERS MOET NOG BEVESTIG WORD)

- **UITNODIGING OM AAN DIE OIE- EN BE-PROSES DEEL TE NEEM**
- **BESKIKBAARHEID VAN KONSEP BESTEKOPNAMEVERSLAE VIR OPENBARE INSAE**

BioTherm Energy (Edms.) Bpk. (hierna BioTherm genoem) het SiVEST SA (Edms.) Bpk. (hierna SiVEST genoem) ingevolge die OIE-regulasies van 2014 en die Nasionale Wet op Omgewingsbestuur, 1998 (Wet 107 van 1998) aangestel as die onafhanklike Omgewingsevalueringspraktisyn (OEP) om die OIE-prosesse vir die beoogde ontwikkeling van die twee Tlisitseng 75 MW fotovoltaïese (FV) sonkragaanlegte en die BE-prosesse vir die gepaardgaande 132 kV kraglyne te onderneem. Die beoogde projekte is in die Noordwes-provinsie naby Lichtenburg geleë en sal as die Tlisitseng 1-sonkrag, Tlisitseng 2-sonkrag, Tlisitseng 1-kraglyn en Tlisitseng 2-kraglyn bekend staan.

SiVEST wil u, as 'n potensiële Belangstellende en/of Geaffekteerde Party (B&GP), uitnooi om aktief by die openbare deelnameproses vir hierdie beoogde projekte betrokke te raak. Die doel van hierdie proses is om:

- toe te sien dat oorweging aan al die tersaaklike omgewingsimpakte geskenk word;
- openbare insette te verseker; en
- besluitnemers van genoegsame inligting te voorsien om 'n ingeligte besluit oor die beoogde aktiwiteite te neem.

Aangeheg is die Agtergrondinligtingsdokument (AID) wat inligting rakende die beoogde projek, asook die OIE-, BE- en openbare deelnameproses bevat.

Die Konsep Bestekopnameverslae (KBV's) vir die beoogde ontwikkeling van die twee (2) beoogde Tlisitseng 75 MW FV-sonkragaanlegte sal ook beskikbaar wees vir openbare kommentaar en insae vanaf **Donderdag, 29 September 2016 tot Maandag, 31 Oktober 2016** (teen sluitingstyd). Indien u 'n elektroniese kopie van die KBV's (op CD) wil ontvang, moet u dit asseblief skriftelik by ons versoek. Gedrukte kopieë van die KBV's kan by enige van die volgende openbare plekke besigtig word:

PLEK	STRAATADRES	TYE	KONTAKNUMMER
Lichtenburg Openbare Biblioteek	Nelson Mandelarylaan, Lichtenburg	Maandae – Donderdae 09h00 – 17h30 Vrydae 09h00 – 17h00 Saterdag 09h00 – 12h00	018 633 3904

Die verslae is ook beskikbaar op SiVEST se webwerf: <http://www.sivest.co.za/>, soek dan die gids '13303 Tlisitseng PV Energy Development'.

Dit is belangrik om daarop te let dat hierdie KBV's die tweede weergawes is wat by die DO ingedien en vir openbare kommentaar beskikbaar gestel word. Op 18 Januarie 2016 is aansoeke om 'n Omgewingsmagtiging (OM) en die KBV's vir die twee (2) beoogde Tlitsiseng 75 MW FV-sonkragaanlegte deur die DO ontvang en verwysingsnommers is vir die beoogde ontwikkelings toegeken (**DO verwysingsnommer: 14/12/16/3/3/2/889 en 14/12/16/3/3/2/890**). Hierdie oorspronklike KBV's is vanaf 11 Januarie 2016 tot 9 Februarie 2016 beskikbaar gestel vir openbare insae. Daarna is die KBV's bygewerk en die Finale Bestekopnameverslae (FBV's) is op 19 Februarie 2016 by die DO ingedien. Nadat die DO die FBV's geëvalueer het, het hulle skrywes uitgereik wat aandui dat die dokumente voldoen het aan die minimumvereistes van die OIE-regulasies, 2014 en dat SiVEST kon voortgaan met die OIE-prosesse. Die oorspronklike FBV's is derhalwe deur die DO aanvaar. Kennis moet egter geneem word dat SiVEST, weens 'n verandering in die uitleg van die twee (2) beoogde Tlitsiseng 75 MW FV-sonkragaanlegte, nie in staat was om die Finale Omgewingsimpakevalueeringsverslae (FOIEV's) in die voorgeskrewe tydsraamwerke in te dien nie. Op 20 Junie 2016 het SiVEST 'n skrywe aan die DO gerig om 'n verlenging van sestig (60) dae ingevolge Regulasie 3(7) van die OIE-regulasies, 2014, te versoek ten einde die spesialiste die geleentheid te bied om hul spesialisverslae in lyn met die hersiene uitlegte by te werk. Op 20 Julie 2016 het die DO 'n skrywe uitgereik waarin die versoek om verlenging geweier is. Dit is die rede waarom die aansoeke om OM ingevolge Regulasie 45 van die OIE-regulasies, 2014, verstryk het en die departementele lêers vir die projek gesluit is.

Ten einde heraansoek te doen om die OM vir die twee (2) beoogde Tlitsiseng 75 MW FV-sonkragaanlegte, het BioTherm SiVEST aangestel om die OIE- en BE-prosesse te hervat. Kennis moet egter geneem word dat alle kommentaar wat tydens die Openbare Deelnameproses (ODP) van Belangstellende en Geaffekteerde Partye (B&GP's) ontvang is (insluitend kommentaar wat tydens vergaderings ontvang is) toe die oorspronklike OIE-prosesse onderneem is, deel van hierdie OIE-proses sal vorm. Die openbare deelnameproses sal weer ingevolge die OIE-regulasies, 2014, onderneem word en alle B&GP's, Belanghebbers en Staatsinstansies sal 'n bykomende geleentheid gegun word om die KBV's na te gaan en kommentaar te lewer.

Deur die meegaande registrasie- en kommentaarvorm in te vul en in te dien, sal u as 'n B&GP op die projek se databasis geregistreer word.

Ons bedank u by voorbaat dat u deel word van die openbare deelnameproses en ons sien uit daarna om u waardevolle insette betreffende die beoogde projek te ontvang.

Die uwe



Andrea Gibb
Omgewingspraktisyn
SiVEST Omgewingsafdeling

Ingeslote dokumentasie: Agtergrondinligtingsdokument (AID)
Registrasie- en Kommentaarvorm
KBV Beknopte Oorsigte



Appendix E3

COMMENTS AND RESPONSE REPORT (C&RR)

BASIC ASSESSMENT (BA) AND ENVIRONMENTAL MANAGEMENT PROGRAMME (EMPr)

COMMENTS AND RESPONSES REPORT – DBAR

**BASIC ASSESSMENTS (BAS) FOR THE PROPOSED DEVELOPMENT OF THE TWO (2)
TLISITSENG 132KV SUBSTATIONS AND POWER LINES NEAR LICHTENBURG, NORTH
WEST PROVINCE**

**SUMMARY OF ENVIRONMENTAL ISSUES/CONCERNS AND SUGGESTIONS RAISED BY INTERESTED
AND/OR AFFECTED PARTIES (I&APS)**

DECEMBER 2015 – MARCH 2017

It should be noted that the Public Participation Process (PPP) for the Basic Assessments has been running concurrently with the PPP for the Environmental Impact Assessments for the Tlisitseng 1 and Tlisitseng 2 PV Energy Facilities. Due to a change in the layout of the proposed Tlisitseng Solar PV Energy Facilities in 2016, SiVEST was not able to submit the FEIARs for the PV facilities within the legislated timeframes. For this reason the original applications for EA for the PV facilities lapsed in accordance with Regulation 45 of the EIA Regulations, 2014 and the departmental file was closed for the project. In order to reapply for EA for the two (2) proposed Tlisitseng solar PV energy facilities, BioTherm has appointed SiVEST to recommence with the EIA process and continue with the BA process for the substations and power lines. All comments received by Interested and Affected Parties (I&APs) during the PPP which was undertaken for the original EIA and BA process (including those received during meetings) will form part of this BA process, and are recorded in this Comments and Responses Report (C&RR). Full record of every issue raised is available from the public participation office and is also included in Appendix E6 of the DBAR. Similar issues raised have been grouped together. Additionally, **all comments raised on the PV energy facilities have also been included in this substation and power line C&RR, as the two projects are intrinsically linked. This is based on the fact that the power lines and substations are required in order to connect the proposed PV energy facilities to the national grid.** The name, affiliation and date of the commentator are also indicated. Technical comments made by the project team are not included in the C&RR.

INDEX TO ISSUES IN THIS TABLE

1.	Socio-Economic and Visual Related Comments/Issues	3
2.	Infrastructure in the Area Related Comments/Issues.....	8
3.	Project Related Comments/Issues.....	10
4.	Associated Infrastructure (Power Line) Related Comments/Issues	10
5.	Biodiversity Related Comments/Issues	13
6.	Heritage Related Comments/Issues	13
7.	Agricultural Related Comments/Issues.....	14
8.	Communication and Information Request Related Comments/Issues	15

ABBREVIATIONS

ATNS	Air Traffic Navigation Services
DAFF	Department of Agriculture Forestry and Fisheries
DBAR	Draft Basic Assessment Report
DEA	Department of Environmental Affairs
DEIAr	Draft Environmental Impact Assessment Report
DSR	Draft Scoping Report
EA	Environmental Authorisation
EIA	Environmental Impact Assessment
EMPr	Environmental Management Programme
EWT	Endangered Wildlife Trust
FEIAr	Final Environmental Impact Assessment Report
FGM	Focus Group Meeting
FSR	Final Scoping Report
NEMA	National Environmental Management Act, 1998 (Act No. 107 of 1998)
PIA	Palaeontological Impact Assessment
PV	Photovoltaic
REIPPPP	Renewable Energy Independent Power Producer Procurement Programme
SACAA	South African Civil Aviation Authority
SAHRA	South African Heritage Resource Agency
SANRAL	South African National Roads Agency SOC Limited

Issue/Comment	Raised By	Response
1. Socio-Economic and Visual Related Comments/Issues		
<p>Mr Samore enquired as to whether the proposed project would create permanent jobs to the surrounding community, expressing his acceptance of the project if this was the case. He also requested that BioTherm Energy avoid causing harm to the local community.</p>	<p>Godfrey Samore North West Provincial Government Email: 2 December 2016</p>	<p>The proposed project would directly create several permanent jobs as well as a large number temporary jobs during construction. It is also expected that the project would indirectly cause the creation of several jobs due to the stimulation of the local economy. As part of the Renewable Energy Independent Power Producer Procurement Programme (REIPPPP), project developers are required to provide a socio-economic development plan which aims to improve the socio-economic standing of the local community. This will be done prior to the start of the project to ensure that, as far as possible, the project developer avoids causing harm and benefits the local community. A detailed Socio-economic Impact Assessment, which assesses both the positive and negative impacts of the development, has been made available for public review and comment during the EIA phase of the project.</p> <p>Lynsey Rimbault, SiVEST</p>
<p>Formally appealed against the building the solar farm close to the Talene small holdings. Noted that his property is 1 Talene, which is adjacent to the project and is thus directly impacted by the building of the proposed solar farm. He purchased the property 12 years ago, as he was interested in living outside of town to get the tranquillity of the outside life and also begin building a business on his property. If the solar project were to continue this would impact on his view of the veld and would negate one of the reasons he initially moved to the farm.</p> <p>Noted that they are also in the process of building an entertainment business on the property. They have already secured business rights for portion of the property where we are developing it. They have, thus far, built the pub and expanded it to the point where it is now a going concern, with a regular customer base. There is also a well-established pool club at the venue, which is one of the biggest clubs in the North West. There is also a kitchen for visitors to eat from, and they have</p>	<p>Mark Hechter Owner of Adjacent Land – Ptn 1 of the Farm Talene No 25 Letter sent via Email: 23 June 2016</p>	<p>The visual impact of the proposed solar PV energy facilities has been assessed in detail as part of the EIA phase visual impact assessment. Following the initial EIA, the layout has been adjusted and the development area has been set back to ensure that no development takes place within 500m from any of the farmhouses located on the adjacent properties.</p> <p>The current and proposed future use of the property is noted and has been taken into consideration in the detailed visual and socio-economic impact assessments in the EIA phase. Although the proposed solar PV energy facilities will change the visual character of the area, there is no evidence to suggest that the proposed project will negatively impact on further expanding the local tourism and entertainment facilities on the farm. PV energy facilities are green technologies and do not create the same negative perceptions as heavy industry factories or coal-fired power stations do. Green energy areas are also seen as an important attraction to visit in tourism regions</p>

Issue/Comment	Raised By	Response
<p>developed a paintball course in the veld close to where the proposed solar farm is to be built.</p> <p>Noted that it is their intention to further develop this business to include the following:</p> <ul style="list-style-type: none"> ▪ A boma area for visitors to use and which will also be rented out to prospective customers and smaller business's in the Lichtenburg area. This will be in the veld and will be available as a function venue for private persons as well as businesses. Part of the attraction for this will be the outside veld and the rustic atmosphere created. ▪ Self-catering chalets for persons staying over for a longer or shorter period. Again the main attraction for these will be the outside life and the view of the veld and the sunsets, which are absolutely spectacular in the area. ▪ Viewing area toward the paintball and the veld, by increasing the size of the pub. This will be a great location for sundowners and a relaxing atmosphere. <p>Noted that the above would not be possible if the solar farm is built in the area.</p> <p>A further impact for them would be the additional people which would now be close to their area. They have sheep and cattle, which are part of their son's developing business. With extra personnel adjacent to their property is would increase their security risk and could possibly put their animals and their visitors at risk. The current environment in South Africa makes this a reality, and being able to give people a safe gateway area is absolutely crucial to the business development working.</p>		<p>(Terradis, 2007). In the Annapurna region of Nepal, there was a definite impact on tourism levels at guesthouses where renewable energy farms were used to supply energy (Prinsloo, 2015). The results indicate that the use of renewable energy and locally developed energy-saving technologies helped to increase tourist numbers. In a study done on visitors to test the impact of renewable energy farms on visitors to Cornwall, it was found that they have a positive attitude towards renewable energy (80%) and just 6% perceived it negatively (The South West Research Company Ltd, 2014). Despite various case studies which prove that tourists perceive renewable energy developments positively, the probability that the proposed project may negatively impact on the tourist potential on Portion 1 of Farm Talene 25 and the concerns raised cannot be negated. In order to accommodate the local land owner and residents, various incentives and compromises should be negotiated. One of these incentives could include educational tours to the proposed solar farm, to be packaged and sold by the businesses surrounding the solar farm. The aesthetic value of the solar farms should also be kept as natural as possible.</p> <p>The impact of the proposed solar PV energy facilities on safety and security has been assessed in detail as part of the EIA phase socio-economic impact assessments. Measures will be put in place to ensure that establishments surrounding the solar PV farm are kept safe. It will also be ensured that expectations regarding employment provision are carefully managed by the project proponent to avoid an influx of hopeful job seekers. If the movement of people increases in the proposed study area, the risk of stock theft may increase and personal safety may decrease. In order to limit this impact, project information will be clearly communicated prior to construction to minimise the influx of migrant job seekers. During construction the rules and regulations will be clearly communicated to all workers that adjacent properties must be respected and avoided. In addition, the movement of workers</p>

Issue/Comment	Raised By	Response
<p>The installation of the solar farm would negatively impact the value of their property, as the main reason for having the property would be in jeopardy, the view, safety and tranquillity of the area.</p> <p>Noted that he is in the process of developing an African Grey farming business. They have built four cages and are currently expanding these into eight cages and have ordered their first two pairs of African Greys. The extra activity in the area could negatively impact on this business.</p> <p>The above mentioned aspects are the main reasons for not supporting the Solar Farm initiative in their area. As landowners, they should be given a fair opportunity to develop their own business as well. The solar farm will negatively impact on their ability to develop this business. Noted that they were their first.</p> <p>There are many other areas in which the solar project can be developed. For example, it could be built deeper into the property of the current owner, so that it could not be seen at all by their property owners and would not have a massive effect on security.</p> <p>As landowners they genuinely hope that their concerns will be taken seriously. Noted that they enjoy where they live and want to stay on and develop the properties. Requested that this opportunity not be destroyed.</p>		<p>and vehicles on the roads linked to the construction activities will be limited to working hours and workdays.</p> <p>The impact of the proposed solar PV energy facilities on property values has been assessed in detail as part of the EIA phase socio-economic impact assessments. The effects on adjacent property values are difficult to determine. Land value could be reduced based on real or perceived adverse effects of the proposed development such as; noise levels, traffic and aesthetics. However, the proposed solar facility, could become a tourist hotspot and could result in the area attracting more people (locals or tourists passing through the area) interested in green technologies. Furthermore, solar PV sites are frequented by businesses tourists and can attract a greater number of visitors and leisure tourists passing through the area. This can increase the turnover of the local tourist attractions and therefore increase the value of these businesses and subsequently the properties themselves.</p> <p>Measures to reduce the impact of noise and dust have been included within the Environmental Management Programme (EMPr) which will reduce the potential impact on the African Grey breeding programme Andrea Gibb, SiVEST</p>
<p>Noted that the letter he submitted on 23 June 2016 should be referred to as it explains his issues with the project, which relate to the proximity of the activity to his property and the visual issues which could affect his lifestyle and business.</p>	<p>Mark Hechter Owner of Adjacent Land – Ptn 1 of the Farm Talene No 25 Comment Form: 2 November 2016</p>	<p>Mr Hechters comments were received on 23 June 2016, during the initial EIA, have been captured and responded to in this C&RR. Refer to the comment and response above. Andrea Gibb, SiVEST</p>
<p>Translation:</p> <ul style="list-style-type: none"> The security aspect is a concern. Noted that they have been living on the property since 1980 and moved to this property 	<p>Gys Goedhals Owner of Adjacent Land Letter: 25 June 2016</p>	<p>The impact of the proposed solar PV energy facilities on safety and security has been assessed in detail as part of the EIA phase socio-economic impact assessments. Measures will be put in place to ensure that establishments surrounding the solar PV farm are kept safe. It will</p>

Issue/Comment	Raised By	Response
<p>for the rest and peace of the area, to avoid the noise and traffic of the town and to enjoy the beauty of the nature.</p> <ul style="list-style-type: none"> ▪ Questioned what impact the erection of temporary living quarters and toilets will this have on the soil and water. ▪ Questioned what would happen should the solar panels break, what will happen to the waste and the potential impact of the liquids on the groundwater i.e. pollution of groundwater. ▪ Noted that the diagrammes that were made available are outdated and not reliable. ▪ What impact will the radiation have on the health of the residents. 		<p>also be ensured that expectations regarding employment provision are carefully managed by the project proponent to avoid an influx of hopeful job seekers. If the movement of people increases in the proposed study area, the risk of stock theft may increase and personal safety may decrease. In order to limit this impact, project information will be clearly communicated prior to construction to minimise the influx of migrant job seekers. During construction the rules and regulations will be clearly communicated to all workers that adjacent properties must be respected and avoided. In addition, the movement of workers and vehicles on the roads linked to the construction activities will be limited to working hours and workdays.</p> <p>The visual impact of the proposed solar PV energy facilities has been assessed in detail as part of the EIA phase visual impact assessment.</p> <p>The traffic impact of the proposed solar PV energy facilities have been assessed and the results are included in the Draft Scoping Report (DSR). A traffic management plan has also been included in the EMPr.</p> <p>The impact of the proposed solar PV energy facilities on surface water has been assessed in detail as part of the detailed EIA phase surface water impact assessment. Mitigation measures have also been included in the EMPr to ensure that onsite toilets do not impact on soil and water. Construction workers will not be housed on the property.</p> <p>Solar panels are manufactured to withstand harsh environments and will not break as a result of hail or high winds. The PV panels will be continuously monitored and maintained and any broken panels will be sent to a recycling facility. Materials that cannot be recycled will be disposed of at a registered disposal facility. The panels do not contain any liquids- hence pollution of groundwater will not occur as a result of the panels breaking.</p>

Issue/Comment	Raised By	Response
		<p>Updated maps indicating the development areas and project layouts are included in the DSR and BID which was made available for public review on 28 September 2016.</p> <p>No radiation is emitted from panels and therefore the proposed solar PV energy facilities will not impact on the health of residents. Andrea Gibb, SiVEST</p>
<p>Translation:</p> <ul style="list-style-type: none"> ▪ Questioned what the profit forecast for the long term would be. ▪ Noted that the value of their land would decrease. Question who would be responsible for valuing and compensating them for the reduction if they were to sell their land. ▪ Questioned how the current farm workers and surrounding community would be affected by the proposed development. ▪ Questioned if the proposed project is to be expanded and how this would affect the surrounding property owners. 	<p>Mark Hechter Owner of Adjacent Land – Ptn 1 of the Farm Talene No 25 Email: 30 June 2016</p>	<p>It is anticipated that each proposed solar PV energy facility will have a capital expenditure (CAPEX) of approximately R 1.85 billion and an operating expenditure (OPEX) of approximately 1.75 billion. Once operational it is anticipated that each proposed solar PV energy facility will produce an average annual revenue of approximately R 350 million.</p> <p>The impact of the proposed solar PV energy facilities on property values have been assessed in detail as part of the EIA phase socio-economic impact assessments. The effects on adjacent property values are difficult to determine. Land value could be reduced based on real or perceived adverse effects of the proposed development such as; noise levels, traffic, aesthetics and possible water supply shortages. However, the proposed solar facility, could become a tourist hotspot and could result in the area attracting more people interested in green technologies. This can increase the value of surrounding businesses and subsequently the properties themselves.</p> <p>The impact of the proposed solar PV energy facilities on the local community have been assessed in detail as part of the EIA phase socio-economic impact assessments. The project will not negatively affect current farm workers as the cultivation practices taking place on the site will continue. The solar PV energy facilities will not disturb any of the centre pivots located on the development site or in the larger area. In addition, each solar PV energy facility will create approximately 130 jobs during construction and 40-50% of these jobs</p>

Issue/Comment	Raised By	Response
		<p>will be made available to local labour. When compared to the employment created by existing activities on the site, the potential for local job creation as a result of the proposed development is significantly higher. As part of the Renewable Energy Independent Power Producer Procurement Programme (REIPPPP), project developers are also required to provide a socio-economic development plan which aims to improve the socio-economic standing of the local community. This will be done prior to the start of the project to ensure that, as far as possible, the project developer avoids causing harm and benefits the local community.</p> <p>At this stage, the applicant is proposing to develop two solar PV energy facilities on Portion 25 of the fam Houthaalboom No. 31 and there are no plans to expand the proposed project.</p> <p>Andrea Gibb, SiVEST</p>
2. Infrastructure in the Area Related Comments/Issues		
<p>Eskom provided their requirements for work at or near Eskom infrastructure. For full details of the requirements, refer to Appendix 7J. They also requested copies of all documents on CD via registered mail.</p>	<p>John Geeringh Eskom GC: Land Development Email: 11 January 2016</p>	<p>Eskom's requirements have been included in the Environmental Management Programme (EMPr) to ensure that any development at or near Eskom infrastructure will adhere to the prescribed requirements. The CD containing all relevant documents was sent to Eskom via registered mail.</p> <p>Lynsey Rimbault, SiVEST</p>
<p>Air Traffic Navigation Services (ATNS) stated that a PV project at the proposed project site location would not affect any of the Annex 14 surfaces or Flight Procedures, however they requested that they be kept informed if the development changes. ATNS also commented that they will duly conduct the general assessment as required when the project is ready for construction.</p>	<p>Simphiwe Masilela ATNS Email: 12 February 2016</p>	<p>The comments from ATNS are noted, and they will continue to be kept informed as the project progresses. All relevant technical details will be provided to ATNS prior to the start of construction.</p> <p>Lynsey Rimbault, SiVEST</p>
<p>Noted that the SACAA has a process whereby permission is applied for with regard to obstacles which could pose an aviation hazard.</p>	<p>Lizell Stroh SACAA: Obstacle Specialist Email: 10 March 2016</p>	<p>The process is noted and the applicant will make a formal application for obstacle approval prior to construction, once the layout has been finalised.</p> <p>Andrea Gibb, SiVEST</p>

BASIC ASSESSMENTS (BAS) AND ENVIRONMENTAL MANAGEMENT PROGRAMME (EMPr) FOR THE PROPOSED DEVELOPMENT OF THE TWO (2) TLISITSENG 132KV SUBSTATIONS AND POWER LINES NEAR LICHTENBURG, NORTH WEST PROVINCE

Draft Basic Assessment Report (DBAR)

Issue/Comment	Raised By	Response
<p>Advised that the proposed services are approved in terms of Section 22 of the Electronic Communications Act 36 of 2005. Details were provided for whom to call before the work commences.</p> <p>It was noted that the positioning of the cables as indicated on the attached plan must be regarded as a guideline only. Telkom does not guarantee that the information provided is complete in every respect, and the fact that the information was requested and provided does not limit the responsibility of anyone who is working in the vicinity of Telkom SA SOC Limited's services, to ensure that no damage is caused to Telkom SA SOC Limited's network. The person or organisation responsible for any damages to cables or telecommunication equipment during their excavations or construction work will be held responsible for the repair costs. Prior to the commencement of any work, Telkom must be contacted to have the position of the cables identified. It was requested that their office be notified after completion of the work.</p>	<p>Linda Meyfarth Telkom SA SOC Limited: Wayleave Office Letter: 23 May 2016</p>	<p>The approval is noted and the conditions of such have been communicated to the applicant for their consideration. The applicant will ensure that Telkom SA SOC Limited is notified prior to and after completion of the work. Andrea Gibb, SiVEST</p>
<p>Noted that the company has no objection to the proposal. The proposal is approved in terms of Section 22 of the Electronic Communications Act 36 of 2005, subject to the stipulations as indicated within the letter.</p> <p>Telkom SA SOC Limited's plant affected by the proposal were indicated in blue on the map. Due to various reasons, the position of the plant cannot be indicated as exact and must be regarded as a guideline only, to inform the presence of the plant. Noted that the Network Field Officer must be contacted prior to excavation to point out the location of the plant on the site. Any removal or repositioning of existing plant must be done on a repayable basis. The requester will be duly held responsible for all costs incurred, should damages be caused to the Telkom services during construction.</p> <p>Telkom do not guarantee the information provided is complete in every respect, and the fact that the information was requested and provided,</p>	<p>B.S. Bezuidenhout Open Serve: Wayleave Section Letter 26 October 2016</p>	<p>The approval is noted and the conditions of such have been communicated to the applicant for their consideration. The applicant will ensure that Telkom SA SOC Limited is notified as required. Andrea Gibb, SiVEST</p>

Issue/Comment	Raised By	Response
<p>does not limit the responsibility of anyone who is working in the vicinity of Telkom SA SOC Limited's services, to ensure that no damage is caused to Telkom SA SOC Limited's network.</p> <p>Note that the approval is valid for six months only. If construction has not commenced within this time the file must be resubmitted for approval. Any changes/deviations from the original planning during or prior to construction must be immediately communicated to this office. Should Telkom SA SOC Limited's infrastructure be damaged while work is undertaken the Toll Free number should be contacted immediately.</p>		
3. Project Related Comments/Issues		
<p>Mr Masipa acknowledged receipt of the Draft Scoping Report and confirmed that the Department will be inviting Independent Power Producers to submit proposals under the REIPPPP during the second quarter of 2016. Mr Masipa stated that the Department has gone through the report and has no comments, however they would like to be kept informed as the project progresses.</p>	<p>Pheladi Masipa Department of Energy Email: 15 February 2016</p>	<p>Mr Masipa's comments are noted and the Department of Energy will continue to receive updates and invitations to comment as the project progresses. Lynsey Rimbault, SiVEST</p>
<p>Requested whether an amended EA has been approved for the proposed development.</p>	<p>Carmen Barends Leads 2 Business Email: 24 February 2017</p>	<p>Noted that the project is currently still in the Impact Phase and SiVEST have not submitted the DEIAr to the DEA yet. Andrea Gibb, SiVEST</p>
4. Associated Infrastructure (Power Line) Related Comments/Issues		
<p>Expressed his dissatisfaction regarding the proposed power line corridor for project 1 crossing through a portion of his property. This corridor will cover approximately one third of his property influencing future plans he may have for that specific section. He therefor does not give consent towards the development of such power lines and servitude road running through his property. He suggested that the power line be established on the same property (Portion 25 of the fam Houthaalboom No. 31) as the solar PV energy facilities are proposed to be established on.</p>	<p>Fazal VarVariawa Owner of Adjacent Land Letter: 22 June 2016</p>	<p>The proposed power lines running from the onsite substations to the Eskom Watershed substation are not part of the EIA processes for the proposed Tlisitseng solar PV energy facilities, and will be applied for as part of separate ongoing Basic Assessment (BA) processes.</p> <p>In addition, the proposed power line corridors have been amended so that they primarily fall within Portion 25 of the fam Houthaalboom No. 31 and no longer traverse the adjacent land located to the south of this farm (i.e. the Talene No 25 farmsteads). Andrea Gibb, SiVEST</p>

Issue/Comment	Raised By	Response
<p>Translation: Noted that he objects to the proposed power line development (Project 1) as the corridor traverses a portion of his property.</p> <ul style="list-style-type: none"> ▪ If he reveals the project to a potential buyer of the property, as it is good practice, it will scare him off. The value of the property will be negatively affected by the power line crossing it. The corridor would have a financial impact as the property value would decrease. ▪ It would provide access to unwanted people and workers which would threaten their privacy and safety. ▪ It would affect the current development on their property as a fence could not be erected without gates. ▪ The security aspect is also a concern. They have lived for a long period of time on the property and they moved here to interact and appreciate nature in a quiet environment. ▪ Clarified that they are in favour of such a development but not on their property. This development can be moved to ensure that the corridor and the remainder of the unsightly development is routed on Portion 25 of the farm Houthaalboom No. 31. ▪ Declared as owner of Portion 2 of the farm Talene 25 IP, District Lichtenburg, that, under no circumstances, do they give permission for this development as it is currently proposed. 	<p>Andries van Rooyen Owner of Adjacent Land – Ptn 2 of the Farm Talene No 25 Letter: 24 June 2016</p>	<p>The proposed power lines running from the onsite substations to the Eskom Watershed substation are not part of the EIA processes for the proposed Tlisitseng solar PV energy facilities, and will be applied for as part of separate ongoing BA processes.</p> <p>In addition, the proposed power line corridors have been amended so that they primarily fall within Portion 25 of the fam Houthaalboom No. 31 and no longer traverse the adjacent land located to the south of this farm (i.e. the Talene No 25 farmsteads).</p> <p>The impact of the proposed power line development on safety and security has been assessed in the socio-economic impact assessments undertaken as part of the BAs. In addition, the impact of the proposed solar PV energy facilities on safety and security has been assessed in detail as part of the EIA phase socio-economic impact assessments.</p> <p>It will be ensured that expectations regarding employment provision are carefully managed by the project proponent to avoid an influx of hopeful job seekers. If the movement of people increases in the proposed study area, the risk of stock theft may increase and personal safety may decrease. In order to limit this impact, project information will be clearly communicated prior to construction to minimise the influx of migrant job seekers. During construction the rules and regulations will be clearly communicated to all workers that adjacent properties must be respected and avoided. In addition, the movement of workers and vehicles on the roads linked to the construction activities will be limited to working hours and workdays.</p> <p>Andrea Gibb, SiVEST</p>
<p>Translation: Noted that the erection of the high steel structures will have the following consequences:</p> <ul style="list-style-type: none"> ▪ Unsightly view of nature on his farm. 	<p>Gys Goedhals Owner of Adjacent Land Letter: 25 June 2016</p>	<p>The proposed power lines running from the onsite substations to the Eskom Watershed substation are not part of the EIA processes for the proposed Tlisitseng solar PV energy facilities, and will be applied for as part of separate ongoing BA processes. The visual impact of the</p>

BASIC ASSESSMENTS (BAS) AND ENVIRONMENTAL MANAGEMENT PROGRAMME (EMPr) FOR THE PROPOSED DEVELOPMENT OF THE TWO (2) TLISITSENG 132KV SUBSTATIONS AND POWER LINES NEAR LICHTENBURG, NORTH WEST PROVINCE

Draft Basic Assessment Report (DBAR)

Issue/Comment	Raised By	Response
<ul style="list-style-type: none"> ▪ Cause mortality of wildlife i.e. vultures flying into the overhead cables. ▪ Chase away small game such as Bat-eared fox (<i>Otocyon megalotis</i>) – bokoorjakkalsies – duikers (<i>Sylvicapra Grimmia</i>) and steenbokkies (<i>Raphicerus Campestris</i>) ▪ Cause veld fires. ▪ The value of the property will be negatively affected and if the project is revealed to a potential buyer, as is good practice, it will scare him off. ▪ It would negatively impact the small holdings as a fence could not be erected and gates would be left open at a regular basis by workers. ▪ It would provide access to unwanted people and workers which would threaten our privacy and safety. ▪ Would like to state it clearly that I am in favour of such a development provided the development and the corridor be moved (and the rest of the unsightly development) to Portion 25 of the fam Houthaalboom No. 31 ▪ I hereby declare, as owner of small holding 3 of the farm Talene 25 IP, District Lichtenburg, that I do not give my permission for this development as it is currently proposed. ▪ As the development falls within a portion of my property, I recommend that the small holding is purchase in it totality at a price determined by us. 		<p>proposed power lines will be assessed in detail as part of the BA visual impact assessment. The impact of the proposed solar PV energy facilities on fauna and avifauna have been assessed in detail as part of the BA biodiversity impact assessment. Mitigation measures have also been included in the EMPr to reduce the impact on large raptors and other small game.</p> <p>In general fires are caused under the following scenarios</p> <ul style="list-style-type: none"> ▪ Flashovers between the conductor and vegetation (or mechanical harvesters) that grow too close. ▪ Falling trees ▪ Poor line maintenance and the pylon falls over <p>Once constructed the power lines will be handed over to Eskom. In recent years Eskom has acquired the use of two satellites to identify and track fires near their lines. An early warning system alerts managers to fires within 5km of power lines. The facility also has a fire weather forecasting system. It is understood this information is available to municipalities and Fire Protection Agencies / Fire Fighting Associations, and interested parties are given access to the website. Eskom also maintains it servitudes, keeping it clear of vegetation that could act as fuel during a fire events.</p> <p>The impact of the proposed power line development on safety and security has been assessed in the socio-economic impact assessments undertaken as part of the BAs. In addition, the impact of the proposed solar PV energy facilities on safety and security has been assessed in detail as part of the EIA phase socio-economic impact assessments.</p> <p>It will be ensured that expectations regarding employment provision are carefully managed by the project proponent to avoid an influx of hopeful job seekers. If the movement of people increases in the</p>

Issue/Comment	Raised By	Response
		<p>proposed study area, the risk of stock theft may increase and personal safety may decrease. In order to limit this impact, project information will be clearly communicated prior to construction to minimise the influx of migrant job seekers. During construction the rules and regulations will be clearly communicated to all workers that adjacent properties must be respected and avoided. In addition, the movement of workers and vehicles on the roads linked to the construction activities will be limited to working hours and workdays.</p> <p>The proposed power line corridors have been amended so that they primarily fall within Portion 25 of the farm Houthaalboom No. 31 and no longer traverse the adjacent land located to the south of this farm (i.e. the Talene No 25 farmsteads).</p> <p>Andrea Gibb, SiVEST</p>
5. Biodiversity Related Comments/Issues		
<p>The Endangered Wildlife Trust (EWT) stated that they have reviewed the Avifaunal Specialist Report and that they have no comments at this stage, but that they would like to be kept up to date with further correspondence on the project.</p>	<p>Lourens Leeuwner Endangered Wildlife Trust Email: 16 February 2016</p>	<p>EWT will continue to receive all project reports and updates.</p> <p>Lynsey Rimbault, SiVEST</p>
6. Heritage Related Comments/Issues		
<p>Noted that SAHRA accepts the Heritage Scoping Report and its recommendations and requires the following studies:</p> <ul style="list-style-type: none"> ▪ A full PIA should be conducted to assess the development area as it is situated in a region of very high palaeontological significance. ▪ A field survey is required during the EIA phase of the project. Should any finds be made during the field survey, they must be assessed according to the methodology stipulated in Appendix C of the Heritage Scoping Report (Fourie, 2014), and a HIA be submitted for comment. <p>SAHRA requires the location of the project to be submitted either through SAHRIS or as a KML file.</p>	<p>Nokukhanya Khumalo Heritage Officer: SAHRA Letter: 10 March 2016</p>	<p>A full PIA has been undertaken to assess the development and the results are included within the DEIAr and will made available to SAHRA for comment. A field survey has been undertaken by the heritage specialist and the finds have been assessed according to the methodology stipulated in the Heritage Scoping Report. The results of the HIA have been included in the DEIAr and will also be made available to SAHRA for comment.</p> <p>The location of the project and all reports and appendices will be made available to on SAHRIS.</p> <p>Andrea Gibb, SiVEST</p>

BASIC ASSESSMENTS (BAS) AND ENVIRONMENTAL MANAGEMENT PROGRAMME (EMPr) FOR THE PROPOSED DEVELOPMENT OF THE TWO (2) TLISITSENG 132KV SUBSTATIONS AND POWER LINES NEAR LICHTENBURG, NORTH WEST PROVINCE

Draft Basic Assessment Report (DBAR)

Issue/Comment	Raised By	Response
<p>Final comments will be issued when the above has been completed. Please submit the Final Scoping Report (FSR) and/or Environmental Impact Assessment upon completion.</p>		
<p>Noted that the requirements mentioned in SAHRA's comments published 10 March 2016 still stand:</p> <ul style="list-style-type: none"> ▪ A full PIA should be conducted to assess the development area as it is situated in a region of very high paleontological significance. ▪ A field survey is required during the EIA phase of the project. Should any finds be made during the field survey, they must be assessed according to the methodology stipulated in Appendix C of the Heritage Scoping Report (Fourie, 2014), and a HIA be submitted for comment. 	<p>Nokukhanya Khumalo Heritage Officer: SAHRA Letter: 27 October 2016</p>	
7. Agricultural Related Comments/Issues		
<p>Noted that in terms of Section 4 of Act, 70 of 1970, DAFF still does not support the development of two Photovoltaic Solar Energy Facilities. Noted that in a previous letter dated 28 July 2016 that the proposed PV facilities will affect the cultivation in the area. The layout plans in the Draft Scoping Report showed that the area of the pivots will be affected, and therefore the proposal will have a negative effect on the agricultural activities taking place on the property. The land can still be used for agricultural purposes with a clear agricultural character which must be preserved for food production. This will set a precedent that will compromise agricultural production in the area. Therefore an alternative area should be identified.</p>	<p>Dr. M.P. Rampedi Department of Agriculture Forestry and Fisheries (DAFF): Deputy Director-General – Forestry and Natural Resource Management Letter: 10 March 2017</p>	<p>The development of the two (2) Tlisitseng facilities will not disturb any of the pivots located on the proposed development site or in the larger area. BioTherm has made great effort to avoid the pivots in the planning of the development areas as such, the pivots have been marked as no-go areas for the project. As such, the PV facilities layout avoids the pivots located on Portion 25 of the Farm Houthaalboom No. 31.</p> <p>Additionally, a detailed Soils and Agricultural Assessment was conducted on the proposed PV Facilities development area. The specialist noted that <i>“due to the generally low potential agricultural environment, little or no mitigation measures are required. The footprint of the development should be kept to a minimum, so that at least the effect on grazing land for livestock is reduced”</i>. In conjunction with the above, after a meeting held with DAFF and Biotherm on 11 October 2016, Biotherm proposed to come up with a rehabilitation plan for the development which will minimise the impacts to agricultural land.</p>

BASIC ASSESSMENTS (BAS) AND ENVIRONMENTAL MANAGEMENT PROGRAMME (EMPr) FOR THE PROPOSED DEVELOPMENT OF THE TWO (2) TLISITSENG 132KV SUBSTATIONS AND POWER LINES NEAR LICHTENBURG, NORTH WEST PROVINCE

Draft Basic Assessment Report (DBAR)

Issue/Comment	Raised By	Response
<p>Noted that in terms of Section 4 of Act, 70 of 1970, it does not grant consent for the above-mentioned application. The proposed project will affect the pivots in the area, therefore an alternative area should be identified. This is a unique agricultural land used for agricultural purposes with a clear agricultural character which must be preserved for food production. This will set a precedent that will compromise agricultural production in the area.</p>	<p>Dr. M.E. Tau Department of Agriculture Forestry and Fisheries (DAFF): Deputy Director-General – Forestry and Natural Resource Management Letter: 28 July 2016</p>	<p>Veronique Evans, SiVEST BioTherm acknowledges the presence of pivots on Portion 25 of the Farm Houhaalboomen No. 31 on which the proposed developments are planned to be located. BioTherm understands and respects the importance of agricultural land by ensuring that it is a no-go area for development. The development of the two (2) Tlisitseng facilities will not disturb any of the pivots located on the proposed development site or in the larger area. BioTherm has made great effort to avoid the pivots in the planning of the development areas as such, the pivots have been marked as no-go areas for the project. The project infrastructure will not cause any disturbance to the pivots. A meeting was requested with DAFF in order to clarify details of the project development area and answer any questions that DAFF may have with regards to the proposed development. Jasandra Nyker, BioTherm Energy</p>
<p>Confirmed receipt of BioTherm's meeting request. Noted that the request has been forwarded to Mabule one of their land use advisors who will schedule a meeting regarding this matter. It was noted that the department at this stage is currently busy with workshops for public comments on the new Preservation and Development of Agricultural Land Bill. Mabule will only be in the office after the 28th of September and will only be in a position to schedule a meeting after this time.</p>	<p>Thoko Buthelezi DAFF: Agricultural Support Group Email: 14 September 2016</p>	<p>BioTherm awaited for further details regarding the meeting. Irene Bezuidenhout, BioTherm Energy</p>
<p>It was noted that DAFF are available for the meeting on 11 October 2016. Requested that BioTherm indicate a suitable time so that the necessary officials can be invited.</p>	<p>Thoko Buthelezi DAFF: Agricultural Support Group Email: 06 October 2016</p>	<p>A meeting invite was sent out and the meeting took place on 11 October 2016 at 10h15. Draft minutes of the meeting held between DAFF and BioTherm have been compiled and were sent to the DEA for consideration. The minutes are also included in the DEIAr. Andrea Gibb, SiVEST</p>
<p>8. Communication and Information Request Related Comments/Issues</p>		
<p>Ms April informed SiVEST that her colleagues Mr Masipa and Mr Govender are the relevant contact people at the Department of Energy.</p>	<p>Lerato April Department of Energy Email: 10 February 2016</p>	<p>Ms April's comment is noted and all future communication with the Department of Energy will be with Mr Masipa and Mr Govender. Lynsey Rimbault, SiVEST</p>

BASIC ASSESSMENTS (BAS) AND ENVIRONMENTAL MANAGEMENT PROGRAMME (EMPr) FOR THE PROPOSED DEVELOPMENT OF THE TWO (2) TLISITSENG 132KV SUBSTATIONS AND POWER LINES NEAR LICHTENBURG, NORTH WEST PROVINCE

Draft Basic Assessment Report (DBAR)

Issue/Comment	Raised By	Response
Requested for the KMZ files of the sites, layouts and routes for the proposed power lines to be sent to him for his records and proper checking against their plans.	John Geeringh Eskom GC: Land Development Email: 22 February 2016	KMLs indicating the site boundaries, power line corridors and substation sites were sent to Mr Geeringh on 07 March 2016. Lynsey Rimbault, SiVEST
Requested for more information regarding the application including a sketch so that they can understand where the proposed infrastructure is to be located.	Annette Van Zyl-Swart Openserve: Planner (Highload Clearances, Wayleave & Poles) Email: 22 February 2016	The notification letter, kmIs and maps of the proposed Tlisitseng PV projects were sent to Ms Van Zyl-Swart on 07 March 2016. Lynsey Rimbault, SiVEST
Noted that SANRAL is only interested in the locality of facilities, substations and power lines, in order to comment on access to the facilities and to determine if any national road is affected. We are not interested in the environmental aspects and supports the approval by the relevant authority. Further noted that they will not attend public hearings due to time constraints.	Jan Oliver SANRAL: Statutory Control Section Emails: 08 March 2016	SANRAL's support for the project is noted. Andrea Gibb, SiVEST
Requested for a locality map showing the location and extent of the two Tlisitseng Solar Energy Facilities so that they can see whether a national road will be affected.		The locality map showing the location of the proposed Tlisitseng PV projects was sent to Jan Oliver on 12 April 2016. Lynsey Rimbault, SiVEST
Noted that the Department received an application for the proposed development of the two Tlisitseng 75MW solar PV energy facilities. They requested for a complete EIA to be sent to them in order for them to process and finalise the application.	Cherity Gombela DAFF: Senior Administration Clerk – Land Use and Soil Management Email: 01 September 2016	The applications for environmental authorisation for the Tlisitseng Solar PV Facilities have lapsed as the legislated timeframes could not be adhered to due to a layout change which affected both projects. As such, applications for environmental authorisation have been resubmitted to the DEA and the project restarted in late September 2016. DAFF will be notified as the project progresses. Andrea Gibb, SiVEST
<p>Translation:</p> <ul style="list-style-type: none"> ▪ It was mentioned that a public meeting was held. Questioned what inputs were received and requested that the points raised be revealed to him in Afrikaans. ▪ Requested that the environmental impact study be made available in Afrikaans ▪ Questioned which newspaper the public meeting was advertised in. 	Gys Goedhals Owner of Adjacent Land Letter: 25 June 2016	<p>A landowner Focus Group Meeting (FGM) was held on the 14th of March 2016. All comments raised at this meeting are provided in Afrikaans and are included within the Meeting Minutes which are attached to the DSR as Appendix 7G.</p> <p>The executive summary of the DSR, FSR, DEIAr and FEIAr will be made available to all I&APs in Afrikaans.</p> <p>The public participation process has been undertaken in accordance with the National Environmental Management Act, 1998 (Act No. 107</p>

BASIC ASSESSMENTS (BAS) AND ENVIRONMENTAL MANAGEMENT PROGRAMME (EMPr) FOR THE PROPOSED DEVELOPMENT OF THE TWO (2) TLISITSENG 132KV SUBSTATIONS AND POWER LINES NEAR LICHTENBURG, NORTH WEST PROVINCE
Draft Basic Assessment Report (DBAR)

Issue/Comment	Raised By	Response
<ul style="list-style-type: none"> Noted that a meeting should be held to provide persons affected the opportunity to provide inputs and to discuss the points raised in his letter dated 25 June 2016. 		<p>of 1998) (NEMA) as amended and the EIA Regulations, under Government Notices No R982, R983, R984 and R985 promulgated on 4 December 2014. Accordingly the EIA processes were advertised in the Noordwester and meeting invitations were sent out via email, post and fax.</p> <p>A Public Meeting, Authority FGM and Landowner FGM were undertaken for the initial EIA in March 2016. These meetings have been deemed sufficient and no further meetings will be held. Mr Goedhals was invited to the Landowner FGM and Public Meeting. All Mr Goedhals comments and questions have been responded to in this C&RR and he will be given further opportunity to comment and raise issues and questions throughout the EIA process.</p>
Requested to be notified if the FEIAR is available yet and what the progress has been made on the Tlisitseng Solar 1 and 2 Projects.	Carmen Barends Leads to Business: Regional Content Researcher Email: 24 August 2016	The applications for environmental authorisation for the Tlisitseng Solar PV Facilities have lapsed as the legislated timeframes could not be adhered to due to a layout change which affected both projects. As such, applications for environmental authorisation have been resubmitted to the DEA and the project restarted in September 2016. You will be notified as the project progresses. Andrea Gibb, SiVEST
Requested that the FSR be uploaded to the SAHRIS Case file (Case ID: 9119). Please ensure that when the DEIAR is completed that it is uploaded to the case file for review.	Natasha Higgitt Heritage Officer: SAHRA Email: 14 November 2016	All documents were uploaded to the relevant case on SAHRIS as requested. Andrea Gibb, SiVEST
Requested for the site locality maps so that they can see where the facilities are located.	Jan Oliver SANRAL: Statutory Control Section Emails: 08 March 2017	The locality map showing the location of the proposed Tlisitseng PV projects was sent to Jan Oliver on 08 March 2017. Andrea Gibb, SiVEST
Requested that the DEIAR to be uploaded to the relevant case on SAHRIS.	Natasha Higgitt Heritage Officer: SAHRA Email: 14 November 2016	All documents were uploaded to the relevant case on SAHRIS as requested. Andrea Gibb, SiVEST
Requested for a map showing the power line corridors in relation to the neighbouring farmers.	Gys Goedhals Owner of Adjacent Land Telephone: 08 March 2017	The maps showing the power line assessment corridors in relation to the neighbouring farms were sent to Gys Goedhals on 08 March 2017.

BASIC ASSESSMENTS (BAS) AND ENVIRONMENTAL MANAGEMENT PROGRAMME (EMPr) FOR THE PROPOSED DEVELOPMENT OF THE TWO (2) TLISITSENG 132KV SUBSTATIONS AND POWER LINES NEAR LICHTENBURG, NORTH WEST PROVINCE

Draft Basic Assessment Report (DBAR)

Issue/Comment	Raised By	Response
		As indicated the corridors have been adjusted so that they do not traverse the neighbouring Talene Farms. Andrea Gibb, SiVEST



Appendix E4

PROOF OF NOTIFICATION TO AUTHORITIES

SIVEST

51 Wessel Road, Rivonia
PO Box 2921, Rivonia
2128
Gauteng, South Africa

Phone + 27 11 798 0600
Fax + 27 11 803 7272
Email info@sivest.co.za
www.sivest.co.za



Established 1952

SANRAL
Private Bag X19
BELLVILLE
7535

Your reference

Our reference 13303 - Grid

Date 23 March 2017

ATTENTION: MS VICTORIA BOTA

Dear Ms V Bota,

BASIC ASSESSMENTS (BAS) FOR THE PROPOSED DEVELOPMENT OF THE TWO (2) TLISITSENG 132KV SUBSTATIONS AND POWER LINES NEAR LICHTENBURG, NORTH WEST PROVINCE

SiVEST is in the process of undertaking the Basic Assessments (BAs) for the proposed development of two (2) 132kV substations and power lines near Lichtenburg in the North West Province, namely the Tlisitseng 1 and Tlisitseng 2 132kV substations and power lines. The proposed substations and power lines will connect the proposed Tlisitseng 1 and Tlisitseng 2 solar PV energy facilities to the existing Eskom Watershed substation.

We would like to take this opportunity to inform you that, in accordance with the National Environmental Management Act (NEMA), the Draft Basic Assessment Report (DBARs) will be made available for public comment and review as from **Thursday 23 March 2017 to Monday 24 April 2017** (end of business day).

An electronic copy (on CD) of the DBARs as well as the accompanying appendices has been posted to you. The reports are also available on SiVEST's website: <http://www.sivest.co.za>, click on downloads and then browse to the folder '13303 Tlisitseng Substations and Power lines. We kindly request that you submit your comments to Public Participation Office at the below details, on or before **Monday 24 April 2017** (end of business day). SiVEST will forward any comments received after this comment and review period directly to the relevant case officer at the Department of Environmental Affairs (DEA).

Should you have any questions or queries please do not hesitate to contact us at:

Andrea Gibb / Veronique Evans
PO BOX 2921, Rivonia, 2128
Tel – (011) 798 0600
Fax – (011) 803 7272
Email – andrea@sivest.co.za / veronique@sivest.co.za

Yours sincerely

Andrea Gibb
Environmental Practitioner
SiVEST Environmental Division

Encl: 1 x Electronic copy (on CD) of the Tlisitseng 1 DBAR and Tlisitseng 2 DBAR

SIVEST

51 Wessel Road, Rivonia
PO Box 2921, Rivonia
2128
Gauteng, South Africa

Phone + 27 11 798 0600
Fax + 27 11 803 7272
Email info@sivest.co.za
www.sivest.co.za



Established 1952

Directorate Land Use and Soil Management
Department of Agriculture, Forestry & Fisheries
Private Bag X120
PRETORIA
0001

Your reference

Our reference 13303 - Grid

Date 23 March 2017

ATTENTION: MS THOKO BUTHELEZI

Dear Ms T Buthelezi,

BASIC ASSESSMENTS (BAS) FOR THE PROPOSED DEVELOPMENT OF THE TWO (2) TLIISITSENG 132KV SUBSTATIONS AND POWER LINES NEAR LICHTENBURG, NORTH WEST PROVINCE

SiVEST is in the process of undertaking the Basic Assessments (BAs) for the proposed development of two (2) 132kV substations and power lines near Lichtenburg in the North West Province, namely the Tlisitseng 1 and Tlisitseng 2 132kV substations and power lines. The proposed substations and power lines will connect the proposed Tlisitseng 1 and Tlisitseng 2 solar PV energy facilities to the existing Eskom Watershed substation.

We would like to take this opportunity to inform you that, in accordance with the National Environmental Management Act (NEMA), the Draft Basic Assessment Report (DBARs) will be made available for public comment and review as from **Thursday 23 March 2017 to Monday 24 April 2017** (end of business day).

An electronic copy (on CD) of the DBARs as well as the accompanying appendices has been posted to you. The reports are also available on SiVEST's website: <http://www.sivest.co.za>, click on downloads and then browse to the folder '13303 Tlisitseng Substations and Power lines. We kindly request that you submit your comments to Public Participation Office at the below details, on or before **Monday 24 April 2017** (end of business day). SiVEST will forward any comments received after this comment and review period directly to the relevant case officer at the Department of Environmental Affairs (DEA).

Should you have any questions or queries please do not hesitate to contact us at:

Andrea Gibb / Veronique Evans
PO BOX 2921, Rivonia, 2128
Tel – (011) 798 0600
Fax – (011) 803 7272
Email – andrea@sivest.co.za / veronique@sivest.co.za

Yours sincerely

Andrea Gibb
Environmental Practitioner
SiVEST Environmental Division

Encl: 1 x Electronic copy (on CD) of the Tlisitseng 1 DBAR and Tlisitseng 2 DBAR

SIVEST

51 Wessel Road, Rivonia
PO Box 2921, Rivonia
2128
Gauteng, South Africa

Phone + 27 11 798 0600
Fax + 27 11 803 7272
Email info@sivest.co.za
www.sivest.co.za



Established 1952

Department of Water and Sanitation
Pvt Bag X5
MMABATHO
2745

Your reference

Our reference 13303 - Grid

Date 23 March 2017

ATTENTION: MS SM MATSHEKA

Dear Ms SM Matsheka,

BASIC ASSESSMENTS (BAS) FOR THE PROPOSED DEVELOPMENT OF THE TWO (2) TLISITSENG 132KV SUBSTATIONS AND POWER LINES NEAR LICHTENBURG, NORTH WEST PROVINCE

SiVEST is in the process of undertaking the Basic Assessments (BAs) for the proposed development of two (2) 132kV substations and power lines near Lichtenburg in the North West Province, namely the Tlisitseng 1 and Tlisitseng 2 132kV substations and power lines. The proposed substations and power lines will connect the proposed Tlisitseng 1 and Tlisitseng 2 solar PV energy facilities to the existing Eskom Watershed substation.

We would like to take this opportunity to inform you that, in accordance with the National Environmental Management Act (NEMA), the Draft Basic Assessment Report (DBARs) will be made available for public comment and review as from **Thursday 23 March 2017 to Monday 24 April 2017** (end of business day).

An electronic copy (on CD) of the DBARs as well as the accompanying appendices has been posted to you. The reports are also available on SiVEST's website: <http://www.sivest.co.za>, click on downloads and then browse to the folder '13303 Tlisitseng Substations and Power lines. We kindly request that you submit your comments to Public Participation Office at the below details, on or before **Monday 24 April 2017** (end of business day). SiVEST will forward any comments received after this comment and review period directly to the relevant case officer at the Department of Environmental Affairs (DEA).

Should you have any questions or queries please do not hesitate to contact us at:

Andrea Gibb / Veronique Evans
PO BOX 2921, Rivonia, 2128
Tel – (011) 798 0600
Fax – (011) 803 7272
Email – andrea@sivest.co.za / veronique@sivest.co.za

Yours sincerely

Andrea Gibb
Environmental Practitioner
SiVEST Environmental Division

Encl: 1 x Electronic copy (on CD) of the Tlisitseng 1 DBAR and Tlisitseng 2 DBAR

SIVEST

51 Wessel Road, Rivonia
PO Box 2921, Rivonia
2128
Gauteng, South Africa

Phone + 27 11 798 0600
Fax + 27 11 803 7272
Email info@sivest.co.za
www.sivest.co.za



Established 1952

Obstacle Evaluator
AIR TRAFFIC AND NAVIGATION SERVICES (ATNS)
Private Bag X15
KEMPTON PARK
1620

Your reference
Our reference 13303 - Grid
Date 23 March 2017

ATTENTION: MS SIMPHIWE MASILELA

Dear Ms S Masilela,

BASIC ASSESSMENTS (BAS) FOR THE PROPOSED DEVELOPMENT OF THE TWO (2) TLISITSENG 132KV SUBSTATIONS AND POWER LINES NEAR LICHTENBURG, NORTH WEST PROVINCE

SiVEST is in the process of undertaking the Basic Assessments (BAs) for the proposed development of two (2) 132kV substations and power lines near Lichtenburg in the North West Province, namely the Tlisitseng 1 and Tlisitseng 2 132kV substations and power lines. The proposed substations and power lines will connect the proposed Tlisitseng 1 and Tlisitseng 2 solar PV energy facilities to the existing Eskom Watershed substation.

We would like to take this opportunity to inform you that, in accordance with the National Environmental Management Act (NEMA), the Draft Basic Assessment Report (DBARs) will be made available for public comment and review as from **Thursday 23 March 2017 to Monday 24 April 2017** (end of business day).

An electronic copy (on CD) of the DBARs as well as the accompanying appendices has been posted to you. The reports are also available on SiVEST's website: <http://www.sivest.co.za>, click on downloads and then browse to the folder '13303 Tlisitseng Substations and Power lines. We kindly request that you submit your comments to Public Participation Office at the below details, on or before **Monday 24 April 2017** (end of business day). SiVEST will forward any comments received after this comment and review period directly to the relevant case officer at the Department of Environmental Affairs (DEA).

Should you have any questions or queries please do not hesitate to contact us at:

Andrea Gibb / Veronique Evans
PO BOX 2921, Rivonia, 2128
Tel – (011) 798 0600
Fax – (011) 803 7272
Email – andrea@sivest.co.za / veronique@sivest.co.za

Yours sincerely

Andrea Gibb
Environmental Practitioner
SiVEST Environmental Division

Encl: 1 x Electronic copy (on CD) of the Tlisitseng 1 DBAR and Tlisitseng 2 DBAR

SIVEST

51 Wessel Road, Rivonia
PO Box 2921, Rivonia
2128
Gauteng, South Africa

Phone + 27 11 798 0600
Fax + 27 11 803 7272
Email info@sivest.co.za
www.sivest.co.za



Established 1952

Municipal Manager
Ngaka Modiri Molema District Municipality
Private Bag X2165
MAHIKENG
2765

Your reference

Our reference 13303 - Grid

Date 23 March 2017

ATTENTION: MS NONO DINCE

Dear Ms N Dince,

BASIC ASSESSMENTS (BAS) FOR THE PROPOSED DEVELOPMENT OF THE TWO (2) TLISITSENG 132KV SUBSTATIONS AND POWER LINES NEAR LICHTENBURG, NORTH WEST PROVINCE

SiVEST is in the process of undertaking the Basic Assessments (BAs) for the proposed development of two (2) 132kV substations and power lines near Lichtenburg in the North West Province, namely the Tlisitseng 1 and Tlisitseng 2 132kV substations and power lines. The proposed substations and power lines will connect the proposed Tlisitseng 1 and Tlisitseng 2 solar PV energy facilities to the existing Eskom Watershed substation.

We would like to take this opportunity to inform you that, in accordance with the National Environmental Management Act (NEMA), the Draft Basic Assessment Report (DBARs) will be made available for public comment and review as from **Thursday 23 March 2017 to Monday 24 April 2017** (end of business day).

An electronic copy (on CD) of the DBARs as well as the accompanying appendices has been posted to you. The reports are also available on SiVEST's website: <http://www.sivest.co.za>, click on downloads and then browse to the folder '13303 Tlisitseng Substations and Power lines. We kindly request that you submit your comments to Public Participation Office at the below details, on or before **Monday 24 April 2017** (end of business day). SiVEST will forward any comments received after this comment and review period directly to the relevant case officer at the Department of Environmental Affairs (DEA).

Should you have any questions or queries please do not hesitate to contact us at:

Andrea Gibb / Veronique Evans
PO BOX 2921, Rivonia, 2128
Tel – (011) 798 0600
Fax – (011) 803 7272
Email – andrea@sivest.co.za / veronique@sivest.co.za

Yours sincerely

Andrea Gibb
Environmental Practitioner
SiVEST Environmental Division

Encl: 1 x Electronic copy (on CD) of the Tlisitseng 1 DBAR and Tlisitseng 2 DBAR

SIVEST

51 Wessel Road, Rivonia
PO Box 2921, Rivonia
2128
Gauteng, South Africa

Phone + 27 11 798 0600
Fax + 27 11 803 7272
Email info@sivest.co.za
www.sivest.co.za



Established 1952

North West Dept of Rural, Environment and Agricultural
Private Bag X2039
MMABATHO
2735

Your reference

Our reference 13303 - Grid

Date 23 March 2017

ATTENTION: MS MAFU NKOSI

Dear Ms Mafu Nkosi,

BASIC ASSESSMENTS (BAS) FOR THE PROPOSED DEVELOPMENT OF THE TWO (2) TLISITSENG 132KV SUBSTATIONS AND POWER LINES NEAR LICHTENBURG, NORTH WEST PROVINCE

SiVEST is in the process of undertaking the Basic Assessments (BAs) for the proposed development of two (2) 132kV substations and power lines near Lichtenburg in the North West Province, namely the Tlisitseng 1 and Tlisitseng 2 132kV substations and power lines. The proposed substations and power lines will connect the proposed Tlisitseng 1 and Tlisitseng 2 solar PV energy facilities to the existing Eskom Watershed substation.

We would like to take this opportunity to inform you that, in accordance with the National Environmental Management Act (NEMA), the Draft Basic Assessment Report (DBARs) will be made available for public comment and review as from **Thursday 23 March 2017 to Monday 24 April 2017** (end of business day).

An electronic copy (on CD) of the DBARs as well as the accompanying appendices has been posted to you. The reports are also available on SiVEST's website: <http://www.sivest.co.za>, click on downloads and then browse to the folder '13303 Tlisitseng Substations and Power lines. We kindly request that you submit your comments to Public Participation Office at the below details, on or before **Monday 24 April 2017** (end of business day). SiVEST will forward any comments received after this comment and review period directly to the relevant case officer at the Department of Environmental Affairs (DEA).

Should you have any questions or queries please do not hesitate to contact us at:

Andrea Gibb / Veronique Evans
PO BOX 2921, Rivonia, 2128
Tel – (011) 798 0600
Fax – (011) 803 7272
Email – andreag@sivest.co.za / veronique@sivest.co.za

Yours sincerely

Andrea Gibb
Environmental Practitioner
SiVEST Environmental Division

Encl: 1 x Electronic copy (on CD) of the Tlisitseng 1 DBAR and Tlisitseng 2 DBAR

SIVEST

51 Wessel Road, Rivonia
PO Box 2921, Rivonia
2128
Gauteng, South Africa

Phone + 27 11 798 0600
Fax + 27 11 803 7272
Email info@sivest.co.za
www.sivest.co.za



Established 1952

DEA – Biodiversity
Private Bag X447
Pretoria
0001

Your reference

Our reference 13303 - Grid

Date 23 March 2017

ATTENTION: MS MMATLALA RABOTHATA

Dear Ms M Rabothata,

BASIC ASSESSMENTS (BAS) FOR THE PROPOSED DEVELOPMENT OF THE TWO (2) TLISITSENG 132KV SUBSTATIONS AND POWER LINES NEAR LICHTENBURG, NORTH WEST PROVINCE

SiVEST is in the process of undertaking the Basic Assessments (BAs) for the proposed development of two (2) 132kV substations and power lines near Lichtenburg in the North West Province, namely the Tlisitseng 1 and Tlisitseng 2 132kV substations and power lines. The proposed substations and power lines will connect the proposed Tlisitseng 1 and Tlisitseng 2 solar PV energy facilities to the existing Eskom Watershed substation.

We would like to take this opportunity to inform you that, in accordance with the National Environmental Management Act (NEMA), the Draft Basic Assessment Report (DBARs) will be made available for public comment and review as from **Thursday 23 March 2017 to Monday 24 April 2017** (end of business day).

An electronic copy (on CD) of the DBARs as well as the accompanying appendices has been posted to you. The reports are also available on SiVEST's website: <http://www.sivest.co.za>, click on downloads and then browse to the folder '13303 Tlisitseng Substations and Power lines. We kindly request that you submit your comments to Public Participation Office at the below details, on or before **Monday 24 April 2017** (end of business day). SiVEST will forward any comments received after this comment and review period directly to the relevant case officer at the Department of Environmental Affairs (DEA).

Should you have any questions or queries please do not hesitate to contact us at:

Andrea Gibb / Veronique Evans
PO BOX 2921, Rivonia, 2128
Tel – (011) 798 0600
Fax – (011) 803 7272
Email – andrea@sivest.co.za / veronique@sivest.co.za

Yours sincerely

Andrea Gibb
Environmental Practitioner
SiVEST Environmental Division

Encl: 1 x Electronic copy (on CD) of the Tlisitseng 1 DBAR and Tlisitseng 2 DBAR

SIVEST

51 Wessel Road, Rivonia
PO Box 2921, Rivonia
2128
Gauteng, South Africa

Phone + 27 11 798 0600
Fax + 27 11 803 7272
Email info@sivest.co.za
www.sivest.co.za



Established 1952

Department of Rural, Environmental, & Agricultural
Development
Pvt Bag X 2039
MMABATHO
2745

Your reference

Our reference 13303 - Grid

Date 23 March 2017

ATTENTION: MS MAFU NKOSI

Dear Ms M Nkosi,

BASIC ASSESSMENTS (BAS) FOR THE PROPOSED DEVELOPMENT OF THE TWO (2) TLISITSENG 132KV SUBSTATIONS AND POWER LINES NEAR LICHTENBURG, NORTH WEST PROVINCE

SiVEST is in the process of undertaking the Basic Assessments (BAs) for the proposed development of two (2) 132kV substations and power lines near Lichtenburg in the North West Province, namely the Tlisitseng 1 and Tlisitseng 2 132kV substations and power lines. The proposed substations and power lines will connect the proposed Tlisitseng 1 and Tlisitseng 2 solar PV energy facilities to the existing Eskom Watershed substation.

We would like to take this opportunity to inform you that, in accordance with the National Environmental Management Act (NEMA), the Draft Basic Assessment Report (DBARs) will be made available for public comment and review as from **Thursday 23 March 2017 to Monday 24 April 2017** (end of business day).

An electronic copy (on CD) of the DBARs as well as the accompanying appendices has been posted to you. The reports are also available on SiVEST's website: <http://www.sivest.co.za>, click on downloads and then browse to the folder '13303 Tlisitseng Substations and Power lines. We kindly request that you submit your comments to Public Participation Office at the below details, on or before **Monday 24 April 2017** (end of business day). SiVEST will forward any comments received after this comment and review period directly to the relevant case officer at the Department of Environmental Affairs (DEA).

Should you have any questions or queries please do not hesitate to contact us at:

Andrea Gibb / Veronique Evans
PO BOX 2921, Rivonia, 2128
Tel – (011) 798 0600
Fax – (011) 803 7272
Email – andrea@sivest.co.za / veronique@sivest.co.za

Yours sincerely

Andrea Gibb
Environmental Practitioner
SiVEST Environmental Division

Encl: 1 x Electronic copy (on CD) of the Tlisitseng 1 DBAR and Tlisitseng 2 DBAR

SIVEST

51 Wessel Road, Rivonia
PO Box 2921, Rivonia
2128
Gauteng, South Africa

Phone + 27 11 798 0600
Fax + 27 11 803 7272
Email info@sivest.co.za
www.sivest.co.za



Established 1952

Assistant Director
Department of Agriculture, Forestry & Fisheries
Private Bag X120
PRETORIA
0001

Your reference

Our reference 13303 - Grid

Date 23 March 2017

ATTENTION: MS MASHUDU MARUBINI

Dear Ms M Marubini,

BASIC ASSESSMENTS (BAS) FOR THE PROPOSED DEVELOPMENT OF THE TWO (2) TLISITSENG 132KV SUBSTATIONS AND POWER LINES NEAR LICHTENBURG, NORTH WEST PROVINCE

SiVEST is in the process of undertaking the Basic Assessments (BAs) for the proposed development of two (2) 132kV substations and power lines near Lichtenburg in the North West Province, namely the Tlisitseng 1 and Tlisitseng 2 132kV substations and power lines. The proposed substations and power lines will connect the proposed Tlisitseng 1 and Tlisitseng 2 solar PV energy facilities to the existing Eskom Watershed substation.

We would like to take this opportunity to inform you that, in accordance with the National Environmental Management Act (NEMA), the Draft Basic Assessment Report (DBARs) will be made available for public comment and review as from **Thursday 23 March 2017 to Monday 24 April 2017** (end of business day).

An electronic copy (on CD) of the DBARs as well as the accompanying appendices has been posted to you. The reports are also available on SiVEST's website: <http://www.sivest.co.za>, click on downloads and then browse to the folder '13303 Tlisitseng Substations and Power lines. We kindly request that you submit your comments to Public Participation Office at the below details, on or before **Monday 24 April 2017** (end of business day). SiVEST will forward any comments received after this comment and review period directly to the relevant case officer at the Department of Environmental Affairs (DEA).

Should you have any questions or queries please do not hesitate to contact us at:

Andrea Gibb / Veronique Evans
PO BOX 2921, Rivonia, 2128
Tel – (011) 798 0600
Fax – (011) 803 7272
Email – andreaq@sivest.co.za / veroniquee@sivest.co.za

Yours sincerely

Andrea Gibb
Environmental Practitioner
SiVEST Environmental Division

Encl: 1 x Electronic copy (on CD) of the Tlisitseng 1 DBAR and Tlisitseng 2 DBAR

SIVEST

51 Wessel Road, Rivonia
PO Box 2921, Rivonia
2128
Gauteng, South Africa

Phone + 27 11 798 0600
Fax + 27 11 803 7272
Email info@sivest.co.za
www.sivest.co.za



Established 1952

NW Department of Energy
Pvt Bag X2075
MMABATHO
2745

Your reference

Our reference 13303 - Grid

Date 23 March 2017

ATTENTION: MS MATSHIDISO MAHLAKU

Dear Ms M Mahlaku,

BASIC ASSESSMENTS (BAS) FOR THE PROPOSED DEVELOPMENT OF THE TWO (2) TLISITSENG 132KV SUBSTATIONS AND POWER LINES NEAR LICHTENBURG, NORTH WEST PROVINCE

SiVEST is in the process of undertaking the Basic Assessments (BAs) for the proposed development of two (2) 132kV substations and power lines near Lichtenburg in the North West Province, namely the Tlisitseng 1 and Tlisitseng 2 132kV substations and power lines. The proposed substations and power lines will connect the proposed Tlisitseng 1 and Tlisitseng 2 solar PV energy facilities to the existing Eskom Watershed substation.

We would like to take this opportunity to inform you that, in accordance with the National Environmental Management Act (NEMA), the Draft Basic Assessment Report (DBARs) will be made available for public comment and review as from **Thursday 23 March 2017 to Monday 24 April 2017** (end of business day).

An electronic copy (on CD) of the DBARs as well as the accompanying appendices has been posted to you. The reports are also available on SiVEST's website: <http://www.sivest.co.za>, click on downloads and then browse to the folder '13303 Tlisitseng Substations and Power lines. We kindly request that you submit your comments to Public Participation Office at the below details, on or before **Monday 24 April 2017** (end of business day). SiVEST will forward any comments received after this comment and review period directly to the relevant case officer at the Department of Environmental Affairs (DEA).

Should you have any questions or queries please do not hesitate to contact us at:

Andrea Gibb / Veronique Evans
PO BOX 2921, Rivonia, 2128
Tel – (011) 798 0600
Fax – (011) 803 7272
Email – andrea@sivest.co.za / veronique@sivest.co.za

Yours sincerely

Andrea Gibb
Environmental Practitioner
SiVEST Environmental Division

Encl: 1 x Electronic copy (on CD) of the Tlisitseng 1 DBAR and Tlisitseng 2 DBAR

SIVEST

51 Wessel Road, Rivonia
PO Box 2921, Rivonia
2128
Gauteng, South Africa

Phone + 27 11 798 0600
Fax + 27 11 803 7272
Email info@sivest.co.za
www.sivest.co.za



Established 1952

Environmental Manager
Ngaka Modiri Molema District Municipality
Private Bag X2165
MAHIKENG
2765

Your reference

Our reference 13303 - Grid

Date 23 March 2017

ATTENTION: MS MARCH LEHLOHONOLO

Dear Ms M Lehlohonolo,

BASIC ASSESSMENTS (BAS) FOR THE PROPOSED DEVELOPMENT OF THE TWO (2) TLISITSENG 132KV SUBSTATIONS AND POWER LINES NEAR LICHTENBURG, NORTH WEST PROVINCE

SiVEST is in the process of undertaking the Basic Assessments (BAs) for the proposed development of two (2) 132kV substations and power lines near Lichtenburg in the North West Province, namely the Tlisitseng 1 and Tlisitseng 2 132kV substations and power lines. The proposed substations and power lines will connect the proposed Tlisitseng 1 and Tlisitseng 2 solar PV energy facilities to the existing Eskom Watershed substation.

We would like to take this opportunity to inform you that, in accordance with the National Environmental Management Act (NEMA), the Draft Basic Assessment Report (DBARs) will be made available for public comment and review as from **Thursday 23 March 2017 to Monday 24 April 2017** (end of business day).

An electronic copy (on CD) of the DBARs as well as the accompanying appendices has been posted to you. The reports are also available on SiVEST's website: <http://www.sivest.co.za>, click on downloads and then browse to the folder '13303 Tlisitseng Substations and Power lines. We kindly request that you submit your comments to Public Participation Office at the below details, on or before **Monday 24 April 2017** (end of business day). SiVEST will forward any comments received after this comment and review period directly to the relevant case officer at the Department of Environmental Affairs (DEA).

Should you have any questions or queries please do not hesitate to contact us at:

Andrea Gibb / Veronique Evans
PO BOX 2921, Rivonia, 2128
Tel – (011) 798 0600
Fax – (011) 803 7272
Email – andreaq@sivest.co.za / veroniquee@sivest.co.za

Yours sincerely

Andrea Gibb
Environmental Practitioner
SiVEST Environmental Division

Encl: 1 x Electronic copy (on CD) of the Tlisitseng 1 DBAR and Tlisitseng 2 DBAR

SIVEST

51 Wessel Road, Rivonia
PO Box 2921, Rivonia
2128
Gauteng, South Africa

Phone + 27 11 798 0600
Fax + 27 11 803 7272
Email info@sivest.co.za
www.sivest.co.za



Established 1952

Obstacle Specialist
SA Civil Aviation Authority (SA CAA)
Private Bag X73
HALFWAY HOUSE
1685

Your reference

Our reference 13303 - Grid

Date 23 March 2017

ATTENTION: MS LIZELL STOH

Dear Ms L Stoh,

BASIC ASSESSMENTS (BAS) FOR THE PROPOSED DEVELOPMENT OF THE TWO (2) TLISITSENG 132KV SUBSTATIONS AND POWER LINES NEAR LICHTENBURG, NORTH WEST PROVINCE

SiVEST is in the process of undertaking the Basic Assessments (BAs) for the proposed development of two (2) 132kV substations and power lines near Lichtenburg in the North West Province, namely the Tlisitseng 1 and Tlisitseng 2 132kV substations and power lines. The proposed substations and power lines will connect the proposed Tlisitseng 1 and Tlisitseng 2 solar PV energy facilities to the existing Eskom Watershed substation.

We would like to take this opportunity to inform you that, in accordance with the National Environmental Management Act (NEMA), the Draft Basic Assessment Report (DBARs) will be made available for public comment and review as from **Thursday 23 March 2017 to Monday 24 April 2017** (end of business day).

An electronic copy (on CD) of the DBARs as well as the accompanying appendices has been posted to you. The reports are also available on SiVEST's website: <http://www.sivest.co.za>, click on downloads and then browse to the folder '13303 Tlisitseng Substations and Power lines. We kindly request that you submit your comments to Public Participation Office at the below details, on or before **Monday 24 April 2017** (end of business day). SiVEST will forward any comments received after this comment and review period directly to the relevant case officer at the Department of Environmental Affairs (DEA).

Should you have any questions or queries please do not hesitate to contact us at:

Andrea Gibb / Veronique Evans
PO BOX 2921, Rivonia, 2128
Tel – (011) 798 0600
Fax – (011) 803 7272
Email – andrea@sivest.co.za / veronique@sivest.co.za

Yours sincerely

Andrea Gibb
Environmental Practitioner
SiVEST Environmental Division

Encl: 1 x Electronic copy (on CD) of the Tlisitseng 1 DBAR and Tlisitseng 2 DBAR

SIVEST

51 Wessel Road, Rivonia
PO Box 2921, Rivonia
2128
Gauteng, South Africa

Phone + 27 11 798 0600
Fax + 27 11 803 7272
Email info@sivest.co.za
www.sivest.co.za



Established 1952

National Department of Energy
Private Bag x96
Pretoria
0001

Your reference

Our reference 13303 - Grid

Date 23 March 2017

ATTENTION: MS LERATO APRIL

Dear Ms L April,

BASIC ASSESSMENTS (BAS) FOR THE PROPOSED DEVELOPMENT OF THE TWO (2) TLISITSENG 132KV SUBSTATIONS AND POWER LINES NEAR LICHTENBURG, NORTH WEST PROVINCE

SiVEST is in the process of undertaking the Basic Assessments (BAs) for the proposed development of two (2) 132kV substations and power lines near Lichtenburg in the North West Province, namely the Tlisitseng 1 and Tlisitseng 2 132kV substations and power lines. The proposed substations and power lines will connect the proposed Tlisitseng 1 and Tlisitseng 2 solar PV energy facilities to the existing Eskom Watershed substation.

We would like to take this opportunity to inform you that, in accordance with the National Environmental Management Act (NEMA), the Draft Basic Assessment Report (DBARs) will be made available for public comment and review as from **Thursday 23 March 2017 to Monday 24 April 2017** (end of business day).

An electronic copy (on CD) of the DBARs as well as the accompanying appendices has been posted to you. The reports are also available on SiVEST's website: <http://www.sivest.co.za>, click on downloads and then browse to the folder '13303 Tlisitseng Substations and Power lines. We kindly request that you submit your comments to Public Participation Office at the below details, on or before **Monday 24 April 2017** (end of business day). SiVEST will forward any comments received after this comment and review period directly to the relevant case officer at the Department of Environmental Affairs (DEA).

Should you have any questions or queries please do not hesitate to contact us at:

Andrea Gibb / Veronique Evans
PO BOX 2921, Rivonia, 2128
Tel – (011) 798 0600
Fax – (011) 803 7272
Email – andreaq@sivest.co.za / veroniquee@sivest.co.za

Yours sincerely

Andrea Gibb
Environmental Practitioner
SiVEST Environmental Division

Encl: 1 x Electronic copy (on CD) of the Tlisitseng 1 DBAR and Tlisitseng 2 DBAR

SIVEST

51 Wessel Road, Rivonia
PO Box 2921, Rivonia
2128
Gauteng, South Africa

Phone + 27 11 798 0600
Fax + 27 11 803 7272
Email info@sivest.co.za
www.sivest.co.za



Established 1952

Environmental Health Practitioner
Ditsobotla Local Municipality
PO Box 7
LICHTENBURG
2740

Your reference

Our reference 13303 - Grid

Date 23 March 2017

ATTENTION: MS KRJ ZANDAMELA

Dear Ms KRJ Zandamela,

BASIC ASSESSMENTS (BAS) FOR THE PROPOSED DEVELOPMENT OF THE TWO (2) TLISITSENG 132KV SUBSTATIONS AND POWER LINES NEAR LICHTENBURG, NORTH WEST PROVINCE

SiVEST is in the process of undertaking the Basic Assessments (BAs) for the proposed development of two (2) 132kV substations and power lines near Lichtenburg in the North West Province, namely the Tlisitseng 1 and Tlisitseng 2 132kV substations and power lines. The proposed substations and power lines will connect the proposed Tlisitseng 1 and Tlisitseng 2 solar PV energy facilities to the existing Eskom Watershed substation.

We would like to take this opportunity to inform you that, in accordance with the National Environmental Management Act (NEMA), the Draft Basic Assessment Report (DBARs) will be made available for public comment and review as from **Thursday 23 March 2017 to Monday 24 April 2017** (end of business day).

An electronic copy (on CD) of the DBARs as well as the accompanying appendices has been posted to you. The reports are also available on SiVEST's website: <http://www.sivest.co.za>, click on downloads and then browse to the folder '13303 Tlisitseng Substations and Power lines. We kindly request that you submit your comments to Public Participation Office at the below details, on or before **Monday 24 April 2017** (end of business day). SiVEST will forward any comments received after this comment and review period directly to the relevant case officer at the Department of Environmental Affairs (DEA).

Should you have any questions or queries please do not hesitate to contact us at:

Andrea Gibb / Veronique Evans
PO BOX 2921, Rivonia, 2128
Tel – (011) 798 0600
Fax – (011) 803 7272
Email – andrea@sivest.co.za / veronique@sivest.co.za

Yours sincerely

Andrea Gibb
Environmental Practitioner
SiVEST Environmental Division

Encl: 1 x Electronic copy (on CD) of the Tlisitseng 1 DBAR and Tlisitseng 2 DBAR

SIVEST

51 Wessel Road, Rivonia
PO Box 2921, Rivonia
2128
Gauteng, South Africa

Phone + 27 11 798 0600
Fax + 27 11 803 7272
Email info@sivest.co.za
www.sivest.co.za



Established 1952

Manager: Corporate Sustainability and Environment
AIR TRAFFIC AND NAVIGATION SERVICES (ATNS)
Private Bag X15
KEMPTON PARK
1620

Your reference

Our reference 13303 - Grid

Date 23 March 2017

ATTENTION: MS JOHANA MOROBANE

Dear Ms J Morobane,

BASIC ASSESSMENTS (BAS) FOR THE PROPOSED DEVELOPMENT OF THE TWO (2) TLISITSENG 132KV SUBSTATIONS AND POWER LINES NEAR LICHTENBURG, NORTH WEST PROVINCE

SiVEST is in the process of undertaking the Basic Assessments (BAs) for the proposed development of two (2) 132kV substations and power lines near Lichtenburg in the North West Province, namely the Tlisitseng 1 and Tlisitseng 2 132kV substations and power lines. The proposed substations and power lines will connect the proposed Tlisitseng 1 and Tlisitseng 2 solar PV energy facilities to the existing Eskom Watershed substation.

We would like to take this opportunity to inform you that, in accordance with the National Environmental Management Act (NEMA), the Draft Basic Assessment Report (DBARs) will be made available for public comment and review as from **Thursday 23 March 2017 to Monday 24 April 2017** (end of business day).

An electronic copy (on CD) of the DBARs as well as the accompanying appendices has been posted to you. The reports are also available on SiVEST's website: <http://www.sivest.co.za>, click on downloads and then browse to the folder '13303 Tlisitseng Substations and Power lines. We kindly request that you submit your comments to Public Participation Office at the below details, on or before **Monday 24 April 2017** (end of business day). SiVEST will forward any comments received after this comment and review period directly to the relevant case officer at the Department of Environmental Affairs (DEA).

Should you have any questions or queries please do not hesitate to contact us at:

Andrea Gibb / Veronique Evans
PO BOX 2921, Rivonia, 2128
Tel – (011) 798 0600
Fax – (011) 803 7272
Email – andrea@sivest.co.za / veronique@sivest.co.za

Yours sincerely

Andrea Gibb
Environmental Practitioner
SiVEST Environmental Division

Encl: 1 x Electronic copy (on CD) of the Tlisitseng 1 DBAR and Tlisitseng 2 DBAR

SIVEST

51 Wessel Road, Rivonia
PO Box 2921, Rivonia
2128
Gauteng, South Africa

Phone + 27 11 798 0600
Fax + 27 11 803 7272
Email info@sivest.co.za
www.sivest.co.za



Established 1952

Department of Water and Sanitation
Pvt Bag X5
MMABATHO
2745

Your reference

Our reference 13303 - Grid

Date 23 March 2017

ATTENTION: MS DORIS MUEMELA

Dear Ms D Maumela,

BASIC ASSESSMENTS (BAS) FOR THE PROPOSED DEVELOPMENT OF THE TWO (2) TLISITSENG 132KV SUBSTATIONS AND POWER LINES NEAR LICHTENBURG, NORTH WEST PROVINCE

SiVEST is in the process of undertaking the Basic Assessments (BAs) for the proposed development of two (2) 132kV substations and power lines near Lichtenburg in the North West Province, namely the Tlisitseng 1 and Tlisitseng 2 132kV substations and power lines. The proposed substations and power lines will connect the proposed Tlisitseng 1 and Tlisitseng 2 solar PV energy facilities to the existing Eskom Watershed substation.

We would like to take this opportunity to inform you that, in accordance with the National Environmental Management Act (NEMA), the Draft Basic Assessment Report (DBARs) will be made available for public comment and review as from **Thursday 23 March 2017 to Monday 24 April 2017** (end of business day).

An electronic copy (on CD) of the DBARs as well as the accompanying appendices has been posted to you. The reports are also available on SiVEST's website: <http://www.sivest.co.za>, click on downloads and then browse to the folder '13303 Tlisitseng Substations and Power lines. We kindly request that you submit your comments to Public Participation Office at the below details, on or before **Monday 24 April 2017** (end of business day). SiVEST will forward any comments received after this comment and review period directly to the relevant case officer at the Department of Environmental Affairs (DEA).

Should you have any questions or queries please do not hesitate to contact us at:

Andrea Gibb / Veronique Evans
PO BOX 2921, Rivonia, 2128
Tel – (011) 798 0600
Fax – (011) 803 7272
Email – andrea@sivest.co.za / veronique@sivest.co.za

Yours sincerely

Andrea Gibb
Environmental Practitioner
SiVEST Environmental Division

Encl: 1 x Electronic copy (on CD) of the Tlisitseng 1 DBAR and Tlisitseng 2 DBAR

SIVEST

51 Wessel Road, Rivonia
PO Box 2921, Rivonia
2128
Gauteng, South Africa

Phone + 27 11 798 0600
Fax + 27 11 803 7272
Email info@sivest.co.za
www.sivest.co.za



Established 1952

Planner
TELKOM
PO Box 1025,
Klerksdorp
2570

Your reference

Our reference 13303 - Grid

Date 23 March 2017

ATTENTION: MS ANNETTE VAN ZYL-SWART

Dear Ms A van Zyl-Swart,

BASIC ASSESSMENTS (BAS) FOR THE PROPOSED DEVELOPMENT OF THE TWO (2) TLISITSENG 132KV SUBSTATIONS AND POWER LINES NEAR LICHTENBURG, NORTH WEST PROVINCE

SiVEST is in the process of undertaking the Basic Assessments (BAs) for the proposed development of two (2) 132kV substations and power lines near Lichtenburg in the North West Province, namely the Tlisitseng 1 and Tlisitseng 2 132kV substations and power lines. The proposed substations and power lines will connect the proposed Tlisitseng 1 and Tlisitseng 2 solar PV energy facilities to the existing Eskom Watershed substation.

We would like to take this opportunity to inform you that, in accordance with the National Environmental Management Act (NEMA), the Draft Basic Assessment Report (DBARs) will be made available for public comment and review as from **Thursday 23 March 2017 to Monday 24 April 2017** (end of business day).

An electronic copy (on CD) of the DBARs as well as the accompanying appendices has been posted to you. The reports are also available on SiVEST's website: <http://www.sivest.co.za>, click on downloads and then browse to the folder '13303 Tlisitseng Substations and Power lines. We kindly request that you submit your comments to Public Participation Office at the below details, on or before **Monday 24 April 2017** (end of business day). SiVEST will forward any comments received after this comment and review period directly to the relevant case officer at the Department of Environmental Affairs (DEA).

Should you have any questions or queries please do not hesitate to contact us at:

Andrea Gibb / Veronique Evans
PO BOX 2921, Rivonia, 2128
Tel – (011) 798 0600
Fax – (011) 803 7272
Email – andreag@sivest.co.za / veronique@sivest.co.za

Yours sincerely

Andrea Gibb
Environmental Practitioner
SiVEST Environmental Division

Encl: 1 x Electronic copy (on CD) of the Tlisitseng 1 DBAR and Tlisitseng 2 DBAR

SIVEST

51 Wessel Road, Rivonia
PO Box 2921, Rivonia
2128
Gauteng, South Africa

Phone + 27 11 798 0600
Fax + 27 11 803 7272
Email info@sivest.co.za
www.sivest.co.za



Established 1952

Department of Agriculture, Forestry & Fisheries
Private Bag X120
PRETORIA
0001

Your reference

Our reference 13303 - Grid

Date 23 March 2017

ATTENTION: MRS ANNELIZA COLLETT

Dear Mrs A Collett,

BASIC ASSESSMENTS (BAS) FOR THE PROPOSED DEVELOPMENT OF THE TWO (2) TLISITSENG 132KV SUBSTATIONS AND POWER LINES NEAR LICHTENBURG, NORTH WEST PROVINCE

SiVEST is in the process of undertaking the Basic Assessments (BAs) for the proposed development of two (2) 132kV substations and power lines near Lichtenburg in the North West Province, namely the Tlisitseng 1 and Tlisitseng 2 132kV substations and power lines. The proposed substations and power lines will connect the proposed Tlisitseng 1 and Tlisitseng 2 solar PV energy facilities to the existing Eskom Watershed substation.

We would like to take this opportunity to inform you that, in accordance with the National Environmental Management Act (NEMA), the Draft Basic Assessment Report (DBARs) will be made available for public comment and review as from **Thursday 23 March 2017 to Monday 24 April 2017** (end of business day).

An electronic copy (on CD) of the DBARs as well as the accompanying appendices has been posted to you. The reports are also available on SiVEST's website: <http://www.sivest.co.za>, click on downloads and then browse to the folder '13303 Tlisitseng Substations and Power lines. We kindly request that you submit your comments to Public Participation Office at the below details, on or before **Monday 24 April 2017** (end of business day). SiVEST will forward any comments received after this comment and review period directly to the relevant case officer at the Department of Environmental Affairs (DEA).

Should you have any questions or queries please do not hesitate to contact us at:

Andrea Gibb / Veronique Evans
PO BOX 2921, Rivonia, 2128
Tel – (011) 798 0600
Fax – (011) 803 7272
Email – andreag@sivest.co.za / veronique@sivest.co.za

Yours sincerely

Andrea Gibb
Environmental Practitioner
SiVEST Environmental Division

Encl: 1 x Electronic copy (on CD) of the Tlisitseng 1 DBAR and Tlisitseng 2 DBAR

SIVEST

51 Wessel Road, Rivonia
PO Box 2921, Rivonia
2128
Gauteng, South Africa

Phone + 27 11 798 0600
Fax + 27 11 803 7272
Email info@sivest.co.za
www.sivest.co.za



Established 1952

NW Department of Energy
Pvt Bag X2075
MMABATHO
2745

Your reference

Our reference 13303 - Grid

Date 23 March 2017

ATTENTION: MR TEBOGO SETHOSA

Dear Mr T Sethosa,

BASIC ASSESSMENTS (BAS) FOR THE PROPOSED DEVELOPMENT OF THE TWO (2) TLISITSENG 132KV SUBSTATIONS AND POWER LINES NEAR LICHTENBURG, NORTH WEST PROVINCE

SiVEST is in the process of undertaking the Basic Assessments (BAs) for the proposed development of two (2) 132kV substations and power lines near Lichtenburg in the North West Province, namely the Tlisitseng 1 and Tlisitseng 2 132kV substations and power lines. The proposed substations and power lines will connect the proposed Tlisitseng 1 and Tlisitseng 2 solar PV energy facilities to the existing Eskom Watershed substation.

We would like to take this opportunity to inform you that, in accordance with the National Environmental Management Act (NEMA), the Draft Basic Assessment Report (DBARs) will be made available for public comment and review as from **Thursday 23 March 2017 to Monday 24 April 2017** (end of business day).

An electronic copy (on CD) of the DBARs as well as the accompanying appendices has been posted to you. The reports are also available on SiVEST's website: <http://www.sivest.co.za>, click on downloads and then browse to the folder '13303 Tlisitseng Substations and Power lines. We kindly request that you submit your comments to Public Participation Office at the below details, on or before **Monday 24 April 2017** (end of business day). SiVEST will forward any comments received after this comment and review period directly to the relevant case officer at the Department of Environmental Affairs (DEA).

Should you have any questions or queries please do not hesitate to contact us at:

Andrea Gibb / Veronique Evans
PO BOX 2921, Rivonia, 2128
Tel – (011) 798 0600
Fax – (011) 803 7272
Email – andreag@sivest.co.za / veronique@sivest.co.za

Yours sincerely

Andrea Gibb
Environmental Practitioner
SiVEST Environmental Division

Encl: 1 x Electronic copy (on CD) of the Tlisitseng 1 DBAR and Tlisitseng 2 DBAR

SIVEST

51 Wessel Road, Rivonia
PO Box 2921, Rivonia
2128
Gauteng, South Africa

Phone + 27 11 798 0600
Fax + 27 11 803 7272
Email info@sivest.co.za
www.sivest.co.za



Established 1952

DEA – Biodiversity
Private Bag X447
Pretoria
0001

Your reference

Our reference 13303 - Grid

Date 23 March 2017

ATTENTION: MR SEOKA LEKOTA

Dear Mr S Lekota,

BASIC ASSESSMENTS (BAS) FOR THE PROPOSED DEVELOPMENT OF THE TWO (2) TLISITSENG 132KV SUBSTATIONS AND POWER LINES NEAR LICHTENBURG, NORTH WEST PROVINCE

SiVEST is in the process of undertaking the Basic Assessments (BAs) for the proposed development of two (2) 132kV substations and power lines near Lichtenburg in the North West Province, namely the Tlisitseng 1 and Tlisitseng 2 132kV substations and power lines. The proposed substations and power lines will connect the proposed Tlisitseng 1 and Tlisitseng 2 solar PV energy facilities to the existing Eskom Watershed substation.

We would like to take this opportunity to inform you that, in accordance with the National Environmental Management Act (NEMA), the Draft Basic Assessment Report (DBARs) will be made available for public comment and review as from **Thursday 23 March 2017 to Monday 24 April 2017** (end of business day).

An electronic copy (on CD) of the DBARs as well as the accompanying appendices has been posted to you. The reports are also available on SiVEST's website: <http://www.sivest.co.za>, click on downloads and then browse to the folder '13303 Tlisitseng Substations and Power lines. We kindly request that you submit your comments to Public Participation Office at the below details, on or before **Monday 24 April 2017** (end of business day). SiVEST will forward any comments received after this comment and review period directly to the relevant case officer at the Department of Environmental Affairs (DEA).

Should you have any questions or queries please do not hesitate to contact us at:

Andrea Gibb / Veronique Evans
PO BOX 2921, Rivonia, 2128
Tel – (011) 798 0600
Fax – (011) 803 7272
Email – andreag@sivest.co.za / veronique@sivest.co.za

Yours sincerely

Andrea Gibb
Environmental Practitioner
SiVEST Environmental Division

Encl: 1 x Electronic copy (on CD) of the Tlisitseng 1 DBAR and Tlisitseng 2 DBAR

Offices: **South Africa** Durban, Johannesburg, Ladysmith, Pietermaritzburg, Richards Bay
Africa Port Louis (Mauritius)

Part of the SiVEST Group

SiVEST SA (Pty) Ltd Registration No. 2000/006717/07 t/a SiVEST



SIVEST

51 Wessel Road, Rivonia
PO Box 2921, Rivonia
2128
Gauteng, South Africa

Phone + 27 11 798 0600
Fax + 27 11 803 7272
Email info@sivest.co.za
www.sivest.co.za



Established 1952

Policy and Advocacy Manager
BirdLife South Africa
PO Box 515
RANDBURG
2125

Your reference

Our reference 13303 - Grid

Date 23 March 2017

ATTENTION: MR SIMON GEAR

Dear Mr S Gear,

BASIC ASSESSMENTS (BAS) FOR THE PROPOSED DEVELOPMENT OF THE TWO (2) TLISITSENG 132KV SUBSTATIONS AND POWER LINES NEAR LICHTENBURG, NORTH WEST PROVINCE

SiVEST is in the process of undertaking the Basic Assessments (BAs) for the proposed development of two (2) 132kV substations and power lines near Lichtenburg in the North West Province, namely the Tlisitseng 1 and Tlisitseng 2 132kV substations and power lines. The proposed substations and power lines will connect the proposed Tlisitseng 1 and Tlisitseng 2 solar PV energy facilities to the existing Eskom Watershed substation.

We would like to take this opportunity to inform you that, in accordance with the National Environmental Management Act (NEMA), the Draft Basic Assessment Report (DBARs) will be made available for public comment and review as from **Thursday 23 March 2017 to Monday 24 April 2017** (end of business day).

An electronic copy (on CD) of the DBARs as well as the accompanying appendices has been posted to you. The reports are also available on SiVEST's website: <http://www.sivest.co.za>, click on downloads and then browse to the folder '13303 Tlisitseng Substations and Power lines. We kindly request that you submit your comments to Public Participation Office at the below details, on or before **Monday 24 April 2017** (end of business day). SiVEST will forward any comments received after this comment and review period directly to the relevant case officer at the Department of Environmental Affairs (DEA).

Should you have any questions or queries please do not hesitate to contact us at:

Andrea Gibb / Veronique Evans
PO BOX 2921, Rivonia, 2128
Tel – (011) 798 0600
Fax – (011) 803 7272
Email – andreag@sivest.co.za / veronique@sivest.co.za

Yours sincerely

Andrea Gibb
Environmental Practitioner
SiVEST Environmental Division

Encl: 1 x Electronic copy (on CD) of the Tlisitseng 1 DBAR and Tlisitseng 2 DBAR

SIVEST

51 Wessel Road, Rivonia
PO Box 2921, Rivonia
2128
Gauteng, South Africa

Phone + 27 11 798 0600
Fax + 27 11 803 7272
Email info@sivest.co.za
www.sivest.co.za



Established 1952

Environmental Manager: Freight Rail
TRANSNET
PO Box 255
BLOEMFONTEIN
9300

Your reference

Our reference 13303 - Grid

Date 23 March 2017

ATTENTION: MR SAM FIFF

Dear Mr S Fiff,

BASIC ASSESSMENTS (BAS) FOR THE PROPOSED DEVELOPMENT OF THE TWO (2) TLISITSENG 132KV SUBSTATIONS AND POWER LINES NEAR LICHTENBURG, NORTH WEST PROVINCE

SiVEST is in the process of undertaking the Basic Assessments (BAs) for the proposed development of two (2) 132kV substations and power lines near Lichtenburg in the North West Province, namely the Tlisitseng 1 and Tlisitseng 2 132kV substations and power lines. The proposed substations and power lines will connect the proposed Tlisitseng 1 and Tlisitseng 2 solar PV energy facilities to the existing Eskom Watershed substation.

We would like to take this opportunity to inform you that, in accordance with the National Environmental Management Act (NEMA), the Draft Basic Assessment Report (DBARs) will be made available for public comment and review as from **Thursday 23 March 2017 to Monday 24 April 2017** (end of business day).

An electronic copy (on CD) of the DBARs as well as the accompanying appendices has been posted to you. The reports are also available on SiVEST's website: <http://www.sivest.co.za>, click on downloads and then browse to the folder '13303 Tlisitseng Substations and Power lines. We kindly request that you submit your comments to Public Participation Office at the below details, on or before **Monday 24 April 2017** (end of business day). SiVEST will forward any comments received after this comment and review period directly to the relevant case officer at the Department of Environmental Affairs (DEA).

Should you have any questions or queries please do not hesitate to contact us at:

Andrea Gibb / Veronique Evans
PO BOX 2921, Rivonia, 2128
Tel – (011) 798 0600
Fax – (011) 803 7272
Email – andreag@sivest.co.za / veronique@sivest.co.za

Yours sincerely

Andrea Gibb
Environmental Practitioner
SiVEST Environmental Division

Encl: 1 x Electronic copy (on CD) of the Tlisitseng 1 DBAR and Tlisitseng 2 DBAR

SIVEST

51 Wessel Road, Rivonia
PO Box 2921, Rivonia
2128
Gauteng, South Africa

Phone + 27 11 798 0600
Fax + 27 11 803 7272
Email info@sivest.co.za
www.sivest.co.za



Established 1952

Manager: Statutory Control
SANRAL
Private Bag X19
BELLVILLE
7535

Your reference

Our reference 13303 - Grid

Date 23 March 2017

ATTENTION: MR SHAUN DYERS

Dear Mr S Dyers,

BASIC ASSESSMENTS (BAS) FOR THE PROPOSED DEVELOPMENT OF THE TWO (2) TLISITSENG 132KV SUBSTATIONS AND POWER LINES NEAR LICHTENBURG, NORTH WEST PROVINCE

SiVEST is in the process of undertaking the Basic Assessments (BAs) for the proposed development of two (2) 132kV substations and power lines near Lichtenburg in the North West Province, namely the Tlisitseng 1 and Tlisitseng 2 132kV substations and power lines. The proposed substations and power lines will connect the proposed Tlisitseng 1 and Tlisitseng 2 solar PV energy facilities to the existing Eskom Watershed substation.

We would like to take this opportunity to inform you that, in accordance with the National Environmental Management Act (NEMA), the Draft Basic Assessment Report (DBARs) will be made available for public comment and review as from **Thursday 23 March 2017 to Monday 24 April 2017** (end of business day).

An electronic copy (on CD) of the DBARs as well as the accompanying appendices has been posted to you. The reports are also available on SiVEST's website: <http://www.sivest.co.za>, click on downloads and then browse to the folder '13303 Tlisitseng Substations and Power lines. We kindly request that you submit your comments to Public Participation Office at the below details, on or before **Monday 24 April 2017** (end of business day). SiVEST will forward any comments received after this comment and review period directly to the relevant case officer at the Department of Environmental Affairs (DEA).

Should you have any questions or queries please do not hesitate to contact us at:

Andrea Gibb / Veronique Evans
PO BOX 2921, Rivonia, 2128
Tel – (011) 798 0600
Fax – (011) 803 7272
Email – andreag@sivest.co.za / veronique@sivest.co.za

Yours sincerely

Andrea Gibb
Environmental Practitioner
SiVEST Environmental Division

Encl: 1 x Electronic copy (on CD) of the Tlisitseng 1 DBAR and Tlisitseng 2 DBAR

SIVEST

51 Wessel Road, Rivonia
PO Box 2921, Rivonia
2128
Gauteng, South Africa

Phone + 27 11 798 0600
Fax + 27 11 803 7272
Email info@sivest.co.za
www.sivest.co.za



Established 1952

Department of Mineral Resources
Private bag a1
KLERKSDORP
2570

Your reference

Our reference 13303 - Grid

Date 23 March 2017

ATTENTION: MR PIETER SWART

Dear Mr P Swart,

BASIC ASSESSMENTS (BAS) FOR THE PROPOSED DEVELOPMENT OF THE TWO (2) TLISITSENG 132KV SUBSTATIONS AND POWER LINES NEAR LICHTENBURG, NORTH WEST PROVINCE

SiVEST is in the process of undertaking the Basic Assessments (BAs) for the proposed development of two (2) 132kV substations and power lines near Lichtenburg in the North West Province, namely the Tlisitseng 1 and Tlisitseng 2 132kV substations and power lines. The proposed substations and power lines will connect the proposed Tlisitseng 1 and Tlisitseng 2 solar PV energy facilities to the existing Eskom Watershed substation.

We would like to take this opportunity to inform you that, in accordance with the National Environmental Management Act (NEMA), the Draft Basic Assessment Report (DBARs) will be made available for public comment and review as from **Thursday 23 March 2017 to Monday 24 April 2017** (end of business day).

An electronic copy (on CD) of the DBARs as well as the accompanying appendices has been posted to you. The reports are also available on SiVEST's website: <http://www.sivest.co.za>, click on downloads and then browse to the folder '13303 Tlisitseng Substations and Power lines. We kindly request that you submit your comments to Public Participation Office at the below details, on or before **Monday 24 April 2017** (end of business day). SiVEST will forward any comments received after this comment and review period directly to the relevant case officer at the Department of Environmental Affairs (DEA).

Should you have any questions or queries please do not hesitate to contact us at:

Andrea Gibb / Veronique Evans
PO BOX 2921, Rivonia, 2128
Tel – (011) 798 0600
Fax – (011) 803 7272
Email – andreag@sivest.co.za / veronique@sivest.co.za

Yours sincerely

Andrea Gibb
Environmental Practitioner
SiVEST Environmental Division

Encl: 1 x Electronic copy (on CD) of the Tlisitseng 1 DBAR and Tlisitseng 2 DBAR

SIVEST

51 Wessel Road, Rivonia
PO Box 2921, Rivonia
2128
Gauteng, South Africa

Phone + 27 11 798 0600
Fax + 27 11 803 7272
Email info@sivest.co.za
www.sivest.co.za



Established 1952

National Department of Energy
Private Bag x96
Pretoria
0001

Your reference

Our reference 13303 - Grid

Date 23 March 2017

ATTENTION: MR PHELADI MASIPHA

Dear Mr P Masipa,

BASIC ASSESSMENTS (BAS) FOR THE PROPOSED DEVELOPMENT OF THE TWO (2) TLISITSENG 132KV SUBSTATIONS AND POWER LINES NEAR LICHTENBURG, NORTH WEST PROVINCE

SiVEST is in the process of undertaking the Basic Assessments (BAs) for the proposed development of two (2) 132kV substations and power lines near Lichtenburg in the North West Province, namely the Tlisitseng 1 and Tlisitseng 2 132kV substations and power lines. The proposed substations and power lines will connect the proposed Tlisitseng 1 and Tlisitseng 2 solar PV energy facilities to the existing Eskom Watershed substation.

We would like to take this opportunity to inform you that, in accordance with the National Environmental Management Act (NEMA), the Draft Basic Assessment Report (DBARs) will be made available for public comment and review as from **Thursday 23 March 2017 to Monday 24 April 2017** (end of business day).

An electronic copy (on CD) of the DBARs as well as the accompanying appendices has been posted to you. The reports are also available on SiVEST's website: <http://www.sivest.co.za>, click on downloads and then browse to the folder '13303 Tlisitseng Substations and Power lines. We kindly request that you submit your comments to Public Participation Office at the below details, on or before **Monday 24 April 2017** (end of business day). SiVEST will forward any comments received after this comment and review period directly to the relevant case officer at the Department of Environmental Affairs (DEA).

Should you have any questions or queries please do not hesitate to contact us at:

Andrea Gibb / Veronique Evans
PO BOX 2921, Rivonia, 2128
Tel – (011) 798 0600
Fax – (011) 803 7272
Email – andreag@sivest.co.za / veronique@sivest.co.za

Yours sincerely

Andrea Gibb
Environmental Practitioner
SiVEST Environmental Division

Encl: 1 x Electronic copy (on CD) of the Tlisitseng 1 DBAR and Tlisitseng 2 DBAR

SIVEST

51 Wessel Road, Rivonia
PO Box 2921, Rivonia
2128
Gauteng, South Africa

Phone + 27 11 798 0600
Fax + 27 11 803 7272
Email info@sivest.co.za
www.sivest.co.za



Established 1952

Head of Department
Department of Water and Sanitation
Pvt Bag x2080
MMABATHO
2745

Your reference

Our reference 13303 - Grid

Date 23 March 2017

ATTENTION: MR M THAMAE

Dear Mr M Thamae,

BASIC ASSESSMENTS (BAS) FOR THE PROPOSED DEVELOPMENT OF THE TWO (2) TLISITSENG 132KV SUBSTATIONS AND POWER LINES NEAR LICHTENBURG, NORTH WEST PROVINCE

SiVEST is in the process of undertaking the Basic Assessments (BAs) for the proposed development of two (2) 132kV substations and power lines near Lichtenburg in the North West Province, namely the Tlisitseng 1 and Tlisitseng 2 132kV substations and power lines. The proposed substations and power lines will connect the proposed Tlisitseng 1 and Tlisitseng 2 solar PV energy facilities to the existing Eskom Watershed substation.

We would like to take this opportunity to inform you that, in accordance with the National Environmental Management Act (NEMA), the Draft Basic Assessment Report (DBARs) will be made available for public comment and review as from **Thursday 23 March 2017 to Monday 24 April 2017** (end of business day).

An electronic copy (on CD) of the DBARs as well as the accompanying appendices has been posted to you. The reports are also available on SiVEST's website: <http://www.sivest.co.za>, click on downloads and then browse to the folder '13303 Tlisitseng Substations and Power lines. We kindly request that you submit your comments to Public Participation Office at the below details, on or before **Monday 24 April 2017** (end of business day). SiVEST will forward any comments received after this comment and review period directly to the relevant case officer at the Department of Environmental Affairs (DEA).

Should you have any questions or queries please do not hesitate to contact us at:

Andrea Gibb / Veronique Evans
PO BOX 2921, Rivonia, 2128
Tel – (011) 798 0600
Fax – (011) 803 7272
Email – andreag@sivest.co.za / veronique@sivest.co.za

Yours sincerely

Andrea Gibb
Environmental Practitioner
SiVEST Environmental Division

Encl: 1 x Electronic copy (on CD) of the Tlisitseng 1 DBAR and Tlisitseng 2 DBAR

SIVEST

51 Wessel Road, Rivonia
PO Box 2921, Rivonia
2128
Gauteng, South Africa

Phone + 27 11 798 0600
Fax + 27 11 803 7272
Email info@sivest.co.za
www.sivest.co.za



Established 1952

Environmental Governance Programme Manager
WESSA
PO Box 12444
Central Hill
Port Elizabeth
6006

Your reference

Our reference 13303 - Grid

Date 23 March 2017

ATTENTION: MR MORGAN GRIFFITHS

Dear Mr M Griffiths,

BASIC ASSESSMENTS (BAS) FOR THE PROPOSED DEVELOPMENT OF THE TWO (2) TLISITSENG 132KV SUBSTATIONS AND POWER LINES NEAR LICHTENBURG, NORTH WEST PROVINCE

SiVEST is in the process of undertaking the Basic Assessments (BAs) for the proposed development of two (2) 132kV substations and power lines near Lichtenburg in the North West Province, namely the Tlisitseng 1 and Tlisitseng 2 132kV substations and power lines. The proposed substations and power lines will connect the proposed Tlisitseng 1 and Tlisitseng 2 solar PV energy facilities to the existing Eskom Watershed substation.

We would like to take this opportunity to inform you that, in accordance with the National Environmental Management Act (NEMA), the Draft Basic Assessment Report (DBARs) will be made available for public comment and review as from **Thursday 23 March 2017 to Monday 24 April 2017** (end of business day).

An electronic copy (on CD) of the DBARs as well as the accompanying appendices has been posted to you. The reports are also available on SiVEST's website: <http://www.sivest.co.za>, click on downloads and then browse to the folder '13303 Tlisitseng Substations and Power lines. We kindly request that you submit your comments to Public Participation Office at the below details, on or before **Monday 24 April 2017** (end of business day). SiVEST will forward any comments received after this comment and review period directly to the relevant case officer at the Department of Environmental Affairs (DEA).

Should you have any questions or queries please do not hesitate to contact us at:

Andrea Gibb / Veronique Evans
PO BOX 2921, Rivonia, 2128
Tel – (011) 798 0600
Fax – (011) 803 7272
Email – andreag@sivest.co.za / veronique@sivest.co.za

Yours sincerely

Andrea Gibb
Environmental Practitioner
SiVEST Environmental Division

Encl: 1 x Electronic copy (on CD) of the Tlisitseng 1 DBAR and Tlisitseng 2 DBAR

SIVEST

51 Wessel Road, Rivonia
PO Box 2921, Rivonia
2128
Gauteng, South Africa

Phone + 27 11 798 0600
Fax + 27 11 803 7272
Email info@sivest.co.za
www.sivest.co.za



Established 1952

Renewable Energy Project
The Endangered Wildlife Trust
86 Capricorn Drive,
Capricorn Business Park
Muizenberg
CAPE TOWN

Your reference

Our reference 13303 - Grid

Date 23 March 2017

ATTENTION: MR LOURENS LEEUNWNER

Dear Mr L Leeuwner,

BASIC ASSESSMENTS (BAS) FOR THE PROPOSED DEVELOPMENT OF THE TWO (2) TLISITSENG 132KV SUBSTATIONS AND POWER LINES NEAR LICHTENBURG, NORTH WEST PROVINCE

SiVEST is in the process of undertaking the Basic Assessments (BAs) for the proposed development of two (2) 132kV substations and power lines near Lichtenburg in the North West Province, namely the Tlisitseng 1 and Tlisitseng 2 132kV substations and power lines. The proposed substations and power lines will connect the proposed Tlisitseng 1 and Tlisitseng 2 solar PV energy facilities to the existing Eskom Watershed substation.

We would like to take this opportunity to inform you that, in accordance with the National Environmental Management Act (NEMA), the Draft Basic Assessment Report (DBARs) will be made available for public comment and review as from **Thursday 23 March 2017 to Monday 24 April 2017** (end of business day).

An electronic copy (on CD) of the DBARs as well as the accompanying appendices has been posted to you. The reports are also available on SiVEST's website: <http://www.sivest.co.za>, click on downloads and then browse to the folder '13303 Tlisitseng Substations and Power lines. We kindly request that you submit your comments to Public Participation Office at the below details, on or before **Monday 24 April 2017** (end of business day). SiVEST will forward any comments received after this comment and review period directly to the relevant case officer at the Department of Environmental Affairs (DEA).

Should you have any questions or queries please do not hesitate to contact us at:

Andrea Gibb / Veronique Evans
PO BOX 2921, Rivonia, 2128
Tel – (011) 798 0600
Fax – (011) 803 7272
Email – andreag@sivest.co.za / veronique@sivest.co.za

Yours sincerely

Andrea Gibb
Environmental Practitioner
SiVEST Environmental Division

Encl: 1 x Electronic copy (on CD) of the Tlisitseng 1 DBAR and Tlisitseng 2 DBAR

SIVEST

51 Wessel Road, Rivonia
PO Box 2921, Rivonia
2128
Gauteng, South Africa

Phone + 27 11 798 0600
Fax + 27 11 803 7272
Email info@sivest.co.za
www.sivest.co.za



Established 1952

Department of Water and Sanitation
Pvt Bag X5
MMABATHO
2745

Your reference

Our reference 13303 - Grid

Date 23 March 2017

ATTENTION: MR L BOGOPA

Dear Mr L Bogopa,

BASIC ASSESSMENTS (BAS) FOR THE PROPOSED DEVELOPMENT OF THE TWO (2) TLISITSENG 132KV SUBSTATIONS AND POWER LINES NEAR LICHTENBURG, NORTH WEST PROVINCE

SiVEST is in the process of undertaking the Basic Assessments (BAs) for the proposed development of two (2) 132kV substations and power lines near Lichtenburg in the North West Province, namely the Tlisitseng 1 and Tlisitseng 2 132kV substations and power lines. The proposed substations and power lines will connect the proposed Tlisitseng 1 and Tlisitseng 2 solar PV energy facilities to the existing Eskom Watershed substation.

We would like to take this opportunity to inform you that, in accordance with the National Environmental Management Act (NEMA), the Draft Basic Assessment Report (DBARs) will be made available for public comment and review as from **Thursday 23 March 2017 to Monday 24 April 2017** (end of business day).

An electronic copy (on CD) of the DBARs as well as the accompanying appendices has been posted to you. The reports are also available on SiVEST's website: <http://www.sivest.co.za>, click on downloads and then browse to the folder '13303 Tlisitseng Substations and Power lines. We kindly request that you submit your comments to Public Participation Office at the below details, on or before **Monday 24 April 2017** (end of business day). SiVEST will forward any comments received after this comment and review period directly to the relevant case officer at the Department of Environmental Affairs (DEA).

Should you have any questions or queries please do not hesitate to contact us at:

Andrea Gibb / Veronique Evans
PO BOX 2921, Rivonia, 2128
Tel – (011) 798 0600
Fax – (011) 803 7272
Email – andreag@sivest.co.za / veronique@sivest.co.za

Yours sincerely

Andrea Gibb
Environmental Practitioner
SiVEST Environmental Division

Encl: 1 x Electronic copy (on CD) of the Tlisitseng 1 DBAR and Tlisitseng 2 DBAR

SIVEST

51 Wessel Road, Rivonia
PO Box 2921, Rivonia
2128
Gauteng, South Africa

Phone + 27 11 798 0600
Fax + 27 11 803 7272
Email info@sivest.co.za
www.sivest.co.za



Established 1952

Statutory Control Section
SANRAL
Private Bag X17
Lynnwood Ridge
0040

Your reference

Our reference 13303 - Grid

Date 23 March 2017

ATTENTION: MR JAN OLIVER

Dear Mr J Oliver,

BASIC ASSESSMENTS (BAS) FOR THE PROPOSED DEVELOPMENT OF THE TWO (2) TLISITSENG 132KV SUBSTATIONS AND POWER LINES NEAR LICHTENBURG, NORTH WEST PROVINCE

SiVEST is in the process of undertaking the Basic Assessments (BAs) for the proposed development of two (2) 132kV substations and power lines near Lichtenburg in the North West Province, namely the Tlisitseng 1 and Tlisitseng 2 132kV substations and power lines. The proposed substations and power lines will connect the proposed Tlisitseng 1 and Tlisitseng 2 solar PV energy facilities to the existing Eskom Watershed substation.

We would like to take this opportunity to inform you that, in accordance with the National Environmental Management Act (NEMA), the Draft Basic Assessment Report (DBARs) will be made available for public comment and review as from **Thursday 23 March 2017 to Monday 24 April 2017** (end of business day).

An electronic copy (on CD) of the DBARs as well as the accompanying appendices has been posted to you. The reports are also available on SiVEST's website: <http://www.sivest.co.za>, click on downloads and then browse to the folder '13303 Tlisitseng Substations and Power lines. We kindly request that you submit your comments to Public Participation Office at the below details, on or before **Monday 24 April 2017** (end of business day). SiVEST will forward any comments received after this comment and review period directly to the relevant case officer at the Department of Environmental Affairs (DEA).

Should you have any questions or queries please do not hesitate to contact us at:

Andrea Gibb / Veronique Evans
PO BOX 2921, Rivonia, 2128
Tel – (011) 798 0600
Fax – (011) 803 7272
Email – andreag@sivest.co.za / veronique@sivest.co.za

Yours sincerely

Andrea Gibb
Environmental Practitioner
SiVEST Environmental Division

Encl: 1 x Electronic copy (on CD) of the Tlisitseng 1 DBAR and Tlisitseng 2 DBAR

SIVEST

51 Wessel Road, Rivonia
PO Box 2921, Rivonia
2128
Gauteng, South Africa

Phone + 27 11 798 0600
Fax + 27 11 803 7272
Email info@sivest.co.za
www.sivest.co.za



Established 1952

Municipal Manager
Ditsobotla Local Municipality
PO Box 7
LICHTENBURG
2740

Your reference

Our reference 13303 - Grid

Date 23 March 2017

ATTENTION: MR J MOLEFE

Dear Mr J Molefe,

BASIC ASSESSMENTS (BAS) FOR THE PROPOSED DEVELOPMENT OF THE TWO (2) TLISITSENG 132KV SUBSTATIONS AND POWER LINES NEAR LICHTENBURG, NORTH WEST PROVINCE

SiVEST is in the process of undertaking the Basic Assessments (BAs) for the proposed development of two (2) 132kV substations and power lines near Lichtenburg in the North West Province, namely the Tlisitseng 1 and Tlisitseng 2 132kV substations and power lines. The proposed substations and power lines will connect the proposed Tlisitseng 1 and Tlisitseng 2 solar PV energy facilities to the existing Eskom Watershed substation.

We would like to take this opportunity to inform you that, in accordance with the National Environmental Management Act (NEMA), the Draft Basic Assessment Report (DBARs) will be made available for public comment and review as from **Thursday 23 March 2017 to Monday 24 April 2017** (end of business day).

An electronic copy (on CD) of the DBARs as well as the accompanying appendices has been posted to you. The reports are also available on SiVEST's website: <http://www.sivest.co.za>, click on downloads and then browse to the folder '13303 Tlisitseng Substations and Power lines. We kindly request that you submit your comments to Public Participation Office at the below details, on or before **Monday 24 April 2017** (end of business day). SiVEST will forward any comments received after this comment and review period directly to the relevant case officer at the Department of Environmental Affairs (DEA).

Should you have any questions or queries please do not hesitate to contact us at:

Andrea Gibb / Veronique Evans
PO BOX 2921, Rivonia, 2128
Tel – (011) 798 0600
Fax – (011) 803 7272
Email – andreag@sivest.co.za / veronique@sivest.co.za

Yours sincerely

Andrea Gibb
Environmental Practitioner
SiVEST Environmental Division

Encl: 1 x Electronic copy (on CD) of the Tlisitseng 1 DBAR and Tlisitseng 2 DBAR

SIVEST

51 Wessel Road, Rivonia
PO Box 2921, Rivonia
2128
Gauteng, South Africa

Phone + 27 11 798 0600
Fax + 27 11 803 7272
Email info@sivest.co.za
www.sivest.co.za



Established 1952

Renewable Projects
SENTECH
Private Bag X06
Honeydew
2040

Your reference

Our reference 13303 - Grid

Date 23 March 2017

ATTENTION: MR JOHAN KOEGELENBERG

Dear Mr J Koegelenberg,

BASIC ASSESSMENTS (BAS) FOR THE PROPOSED DEVELOPMENT OF THE TWO (2) TLISITSENG 132KV SUBSTATIONS AND POWER LINES NEAR LICHTENBURG, NORTH WEST PROVINCE

SiVEST is in the process of undertaking the Basic Assessments (BAs) for the proposed development of two (2) 132kV substations and power lines near Lichtenburg in the North West Province, namely the Tlisitseng 1 and Tlisitseng 2 132kV substations and power lines. The proposed substations and power lines will connect the proposed Tlisitseng 1 and Tlisitseng 2 solar PV energy facilities to the existing Eskom Watershed substation.

We would like to take this opportunity to inform you that, in accordance with the National Environmental Management Act (NEMA), the Draft Basic Assessment Report (DBARs) will be made available for public comment and review as from **Thursday 23 March 2017 to Monday 24 April 2017** (end of business day).

An electronic copy (on CD) of the DBARs as well as the accompanying appendices has been posted to you. The reports are also available on SiVEST's website: <http://www.sivest.co.za>, click on downloads and then browse to the folder '13303 Tlisitseng Substations and Power lines. We kindly request that you submit your comments to Public Participation Office at the below details, on or before **Monday 24 April 2017** (end of business day). SiVEST will forward any comments received after this comment and review period directly to the relevant case officer at the Department of Environmental Affairs (DEA).

Should you have any questions or queries please do not hesitate to contact us at:

Andrea Gibb / Veronique Evans
PO BOX 2921, Rivonia, 2128
Tel – (011) 798 0600
Fax – (011) 803 7272
Email – andreag@sivest.co.za / veronique@sivest.co.za

Yours sincerely

Andrea Gibb
Environmental Practitioner
SiVEST Environmental Division

Encl: 1 x Electronic copy (on CD) of the Tlisitseng 1 DBAR and Tlisitseng 2 DBAR

SIVEST

51 Wessel Road, Rivonia
PO Box 2921, Rivonia
2128
Gauteng, South Africa

Phone + 27 11 798 0600
Fax + 27 11 803 7272
Email info@sivest.co.za
www.sivest.co.za



Established 1952

Chief Planner
ESKOM
PO Box 1091
JOHANNESBURG
2000

Your reference

Our reference 13303 - Grid

Date 23 March 2017

ATTENTION: MR JOHN GEERINGH

Dear Mr J Geeringh,

BASIC ASSESSMENTS (BAS) FOR THE PROPOSED DEVELOPMENT OF THE TWO (2) TLISITSENG 132KV SUBSTATIONS AND POWER LINES NEAR LICHTENBURG, NORTH WEST PROVINCE

SiVEST is in the process of undertaking the Basic Assessments (BAs) for the proposed development of two (2) 132kV substations and power lines near Lichtenburg in the North West Province, namely the Tlisitseng 1 and Tlisitseng 2 132kV substations and power lines. The proposed substations and power lines will connect the proposed Tlisitseng 1 and Tlisitseng 2 solar PV energy facilities to the existing Eskom Watershed substation.

We would like to take this opportunity to inform you that, in accordance with the National Environmental Management Act (NEMA), the Draft Basic Assessment Report (DBARs) will be made available for public comment and review as from **Thursday 23 March 2017 to Monday 24 April 2017** (end of business day).

An electronic copy (on CD) of the DBARs as well as the accompanying appendices has been posted to you. The reports are also available on SiVEST's website: <http://www.sivest.co.za>, click on downloads and then browse to the folder '13303 Tlisitseng Substations and Power lines. We kindly request that you submit your comments to Public Participation Office at the below details, on or before **Monday 24 April 2017** (end of business day). SiVEST will forward any comments received after this comment and review period directly to the relevant case officer at the Department of Environmental Affairs (DEA).

Should you have any questions or queries please do not hesitate to contact us at:

Andrea Gibb / Veronique Evans
PO BOX 2921, Rivonia, 2128
Tel – (011) 798 0600
Fax – (011) 803 7272
Email – andreag@sivest.co.za / veronique@sivest.co.za

Yours sincerely

Andrea Gibb
Environmental Practitioner
SiVEST Environmental Division

Encl: 1 x Electronic copy (on CD) of the Tlisitseng 1 DBAR and Tlisitseng 2 DBAR

SIVEST

51 Wessel Road, Rivonia
PO Box 2921, Rivonia
2128
Gauteng, South Africa

Phone + 27 11 798 0600
Fax + 27 11 803 7272
Email info@sivest.co.za
www.sivest.co.za



Established 1952

SA Civil Aviation Authority (SA CAA)
Private Bag X73
HALFWAY HOUSE
1685

Your reference

Our reference 13303 - Grid

Date 23 March 2017

ATTENTION: MR HARRY ROBERTS

Dear Mr H Roberts,

BASIC ASSESSMENTS (BAS) FOR THE PROPOSED DEVELOPMENT OF THE TWO (2) TLISITSENG 132KV SUBSTATIONS AND POWER LINES NEAR LICHTENBURG, NORTH WEST PROVINCE

SiVEST is in the process of undertaking the Basic Assessments (BAs) for the proposed development of two (2) 132kV substations and power lines near Lichtenburg in the North West Province, namely the Tlisitseng 1 and Tlisitseng 2 132kV substations and power lines. The proposed substations and power lines will connect the proposed Tlisitseng 1 and Tlisitseng 2 solar PV energy facilities to the existing Eskom Watershed substation.

We would like to take this opportunity to inform you that, in accordance with the National Environmental Management Act (NEMA), the Draft Basic Assessment Report (DBARs) will be made available for public comment and review as from **Thursday 23 March 2017 to Monday 24 April 2017** (end of business day).

An electronic copy (on CD) of the DBARs as well as the accompanying appendices has been posted to you. The reports are also available on SiVEST's website: <http://www.sivest.co.za>, click on downloads and then browse to the folder '13303 Tlisitseng Substations and Power lines. We kindly request that you submit your comments to Public Participation Office at the below details, on or before **Monday 24 April 2017** (end of business day). SiVEST will forward any comments received after this comment and review period directly to the relevant case officer at the Department of Environmental Affairs (DEA).

Should you have any questions or queries please do not hesitate to contact us at:

Andrea Gibb / Veronique Evans
PO BOX 2921, Rivonia, 2128
Tel – (011) 798 0600
Fax – (011) 803 7272
Email – andreag@sivest.co.za / veronique@sivest.co.za

Yours sincerely

Andrea Gibb
Environmental Practitioner
SiVEST Environmental Division

Encl: 1 x Electronic copy (on CD) of the Tlisitseng 1 DBAR and Tlisitseng 2 DBAR

SIVEST

51 Wessel Road, Rivonia
PO Box 2921, Rivonia
2128
Gauteng, South Africa

Phone + 27 11 798 0600
Fax + 27 11 803 7272
Email info@sivest.co.za
www.sivest.co.za



Established 1952

Manager: Site Categorisation
Square Kilometre Array (SKA)
PO Box 522
SAXONWOLD
2132

Your reference

Our reference 13303 - Grid

Date 23 March 2017

ATTENTION: DR ADRIAN TIPLADY

Dear Dr A Tiplady,

BASIC ASSESSMENTS (BAS) FOR THE PROPOSED DEVELOPMENT OF THE TWO (2) TLISITSENG 132KV SUBSTATIONS AND POWER LINES NEAR LICHTENBURG, NORTH WEST PROVINCE

SiVEST is in the process of undertaking the Basic Assessments (BAs) for the proposed development of two (2) 132kV substations and power lines near Lichtenburg in the North West Province, namely the Tlisitseng 1 and Tlisitseng 2 132kV substations and power lines. The proposed substations and power lines will connect the proposed Tlisitseng 1 and Tlisitseng 2 solar PV energy facilities to the existing Eskom Watershed substation.

We would like to take this opportunity to inform you that, in accordance with the National Environmental Management Act (NEMA), the Draft Basic Assessment Report (DBARs) will be made available for public comment and review as from **Thursday 23 March 2017 to Monday 24 April 2017** (end of business day).

An electronic copy (on CD) of the DBARs as well as the accompanying appendices has been posted to you. The reports are also available on SiVEST's website: <http://www.sivest.co.za>, click on downloads and then browse to the folder '13303 Tlisitseng Substations and Power lines. We kindly request that you submit your comments to Public Participation Office at the below details, on or before **Monday 24 April 2017** (end of business day). SiVEST will forward any comments received after this comment and review period directly to the relevant case officer at the Department of Environmental Affairs (DEA).

Should you have any questions or queries please do not hesitate to contact us at:

Andrea Gibb / Veronique Evans
PO BOX 2921, Rivonia, 2128
Tel – (011) 798 0600
Fax – (011) 803 7272
Email – andreag@sivest.co.za / veronique@sivest.co.za

Yours sincerely

Andrea Gibb
Environmental Practitioner
SiVEST Environmental Division

Encl: 1 x Electronic copy (on CD) of the Tlisitseng 1 DBAR and Tlisitseng 2 DBAR



Appendix E5

I&AP DATABASE

**DRAFT BASIC ASSESSMENT PROPOSED CONSTRUCTION OF THE TLISITSENG 1 AND TLISITSENG 2 132KV
SUBSTATION AND POWER LINE NEAR LICHTENBURG, NORTH WEST PROVINCE**

DISTRIBUTION OF THE DRAFTBASIC ASSESSMENT REPORT (DBAR)

MARCH 2017

First Name	Last Name	Company
Marlaine	Andersen	Leads 2 Business
Lerato	April	Department of Energy
Carmen	Barends	Leads 2 Business
L	Bogopa	North West DWS
Victoria	Bota	SANRAL
Steven	Botlhoko	Ditsobola Local Municipality
Thoko	Buthelezi	Dept of Agriculture, Forestry & Fisheries
Anneliza	Collett	Department of Agriculture, Forestry & Fisheries
Nono	Dince	Ngaka Modiri Molema District Municipality
Tsholofelo	Dintwe	NW Dept of Rural, Environment and Agricultural
Shaun	Dyers	SANRAL Western Region
Neil	Faber	
Sam	Fiff	Transnet Freight Rail (Jhb)
Simon	Gear	Birdlife South Africa
John	Geeringh	Eskom: Transmission
Gysbert	Goedhals	Landowner: Talene 3
Morgan	Griffiths	WESSA: National
Ferdinand	Hartzenberg	Kleinuitschot Boerdery
Mark	Hechter	Landowner: Talene 1
J	Hechter	Landowner: Talenehoewe 1
Natasha	Higgitt	South African Heritage Resources Agency
Lesego	Holele	Ditsobola Local Municipality
Nokukhanya	Khumalo	SAHRA
Johan	Koegelenberg	SENTECH
Eric	Landsman	Ngaka Modiri Molema District Municipality
Lourens	Leeuwner	EWT
Seoka	Lekota	Department of Environmental Affairs
Mamokete	Mafume	Eskom Transmission
Alfred	Mafune	NW Department of Roads and Transport
Matshediso	Mahlaku	North West Department of Energy
Pogiso	Maitshotlo	Ditsobola Local Municipality
Tshepo Justice	Makolomakwa	Ngaka Modiri Molema District Municipality
Lehlohonolo	March	Ngaka Modiri Molema District Municipality
Mashudu	Marubini	DAFF Provinical Department
Simphiwe	Masilela	Air Traffic Navigation Services
Pheladi	Masipa	Department of Energy
SM	Matsheka	North West DWS
Ntanganedzeni	Maumela	Department of Agriculture, Forestry & Fisheries
Abe	Metswamere	Ngaka Modiri Molema District Municipality
M W	Moholatsi	Ngaka Modiri molema District Municipality
J	Molefe	Ditsobotla Local Municipality
Johanna	Morobane	Air Traffic Navigation Services
JH	Nel	Landowner: Houthaalbomen
Mafu	Nkosi	North West Dept of Rural, Environment and Agricultural
Chris	Nthaudi	Telkom SA SOC Limited

J	Oliver	SANRAL
Jan	Olivier	The South African National Road Agency SOC Limited
Mpho	Phiri	Ngaka Modiri Molema District
G	Pieterse	Landowner: Houthaalbomen
Mmatlala	Rabothata	Department of Environmental Affairs
Harry	Roberts	SA CAA
Godfrey	Samore	Community Police Forum / LIBRARIAN
Yoliswa	Sechoaro	Ngaka Modiri Molema District Municipality
Tebogo	Sethosa	North West Department of Energy
Jan	Steunman	Landowner: Lichtenburg Farm and Townlands 27 Portion 10
Mariette	Steynberg	
Lizell	Stroh	SA Civil Aviation Authority
Pieter	Swart	Department of Mineral Resources
M	Thamae	North West Department of Roads and Transport
Claire	Threadingham	Leads 2 Business
Adriaan	Tiplady	Square Kilometre Array
Andries	Van Rooyen	
Annette	Van Zyl-Swart	Telkom SA SOC Limited
Anna	Variwa	Landowner: Talene 4
Kobus	Visser	Agri SA
Fasel	Wariyawu	Talene Landbouhoewe
Wessel	Wessels	Landowner: Houthaalboomen 31, Ptns 3, 4, 5, 6, 7
KRJ	Zandamela	Ditsobotla Local Municipality

DRAFT BASIC ASSESSMENT FOR THE PROPOSED CONSTRUCTION OF THE TLISITSENG 1 AND TLISITSENG 2 132KV SUBSTATION AND POWER LINE NEAR LICHTENBURG, NORTH WEST PROVINCE

DISTRIBUTION OF THE DRAFT BASIC ASSESSMENT REPORT (DBAR) TO ORGANS OF STATE FOR COMMENT

TITLE	SURNAME	NAME	POSITION	POSTAL ADDRESS	EMAIL ADDRESS
DITSOBOTLA LOCAL MUNICIPALITY					
Mr	Molefe	J	Municipal Manager	PO Box 7 LICHTENBURG 2740	digoamajel@mitsobotla.co.za
Ms	Zandamela	KRJ	Environmental Health Practitioner	PO Box 7 LICHTENBURG 2740	info@mitsobotla.gov.za
NGAKA MODIRI MOLEMA DISTRICT MUNICIPALITY					
Ms	Dince	Nono	Municipal Manager	Private Bag X2165 MAHIKENG 2765	municipalmanager@nmmdm.gov.za
Ms	March	Lehlohonolo	Environmental Manager	Private Bag X2165 MAHIKENG 2765	matsosel@nmmdm.gov.za
DEPARTMENT OF ENERGY					
<i>Provincial - NORTH WEST</i>					
Mr	Sethosa	Tebogo		Pvt Bag X2075 MMABATHO 2745	Tebogo.sethosa@energy.gov.za
Ms	Mahlaku	Matshediso		Pvt Bag X2075 MMABATHO 2745	Matshediso.mahlaku@energy.gov.za
<i>National</i>					
Ms	April	Lerato		Private Bag x96 Pretoria 0001	lerato.april@energy.gov.za
Mr	Masipa	Pheladi		Private Bag x96 Pretoria 0001	Pheladi.Masipa@energy.gov.za
DEPARTMENT OF WATER AND SANITATION					
Ms	Matsheka	SM		Private Bag X5 MMABATHO 2735	MatshekaS@dwa.gov.za
Mr	Bogopa	L		Private Bag X5 MMABATHO 2735	
Ms	Maumela	Doris		Private Bag X5 MMABATHO 2735	MaumelaD@dws.gov.za
NORTH WEST DEPARTMENT OF RURAL, ENVIRONMENTAL AND AGRICULTURAL DEVELOPMENT					
Ms	Mafu	Nkosi	Acting Director	Private Bag X2039 MMABATHO 2735	tmnkosi@nwpg.gov.za
DEPARTMENT OF AGRICULTURE, FORESTRY AND FISHERIES					
Mrs	Collett	Anneliza		Private Bag X120 PRETORIA 0001	annelizac@nda.agric.za
Ms	Buthelezi	Thoko	Directorate Land Use and	Private Bag X120 PRETORIA 0001	ThokoB@nda.agric.za
Ms	Marubini	Mashudu	Assistant Director	Private Bag X120 PRETORIA 0001	mashuduma@daff.gov.za
DEPARTMENT OF MINERAL RESOURCES (DMR)					
Mr	Swart	Pieter		Private bag a1 KLERKSDORP 2570	Pieter.Swart@dmr.gov.za

TITLE	SURNAME	NAME	POSITION	POSTAL ADDRESS	EMAIL ADDRESS
SANRAL					
	Oliver	Jan	Statutory Control Section	Private Bag X17 Lynnwood Ridge 0040	oliverj@nra.co.za
Mr	Dyers	Shaun	Manager: Statutory Control	Private Bag X19 BELLVILLE 7535	Dyerss@nra.co.za
Ms	Bota	Victoria			BotaV@nra.co.za
NORTH WEST DEPARTMENT OF ROADS AND TRANSPORT					
Mr	Thamae	M	Head of Department	Private Bag x2080 MMABATHO 2735	
SAHRA: HEAD OFFICE					
Ms	Higgitt	Natasha	Heritage Officer: Archaeology, Palaeontology and Meteorites Unit	PO Box 4637 CAPE TOWN 8000	nhiggitt@sahra.org.za
	Khumalo	Nokukhanya	Heritage Officer	PO Box 4637 CAPE TOWN 8000	nkhumalo@sahra.or.za
ESKOM					
Mr	Geeringh	John	Chief Planner	PO Box 1091 JOHANNESBURG 2000	GeerinJH@eskom.co.za
SA CIVIL AVIATION AUTHORITY (SA CAA)					
Mr	Roberts	Harry		Private Bag X73 HALFWAY HOUSE 1685	Robertsh@caa.za
Ms	Stoh	Lizell	Obstacle Specialist	Private Bag X73 HALFWAY HOUSE 1685	strohl@caa.co.za
AIR TRAFFIC AND NAVIGATION SERVICES (ATNS)					
Ms	Morobane	Johanna	Manager: Corporate Sustainability and Environment	Private Bag X15 KEMPTON PARK 1620	JohannaM@atns.co.za
Mr	Masilela	Simphiwe	Obstacle Evaluator		SimphiweM@atns.co.za
TRANSNET FREIGHT RAIL					
Mr	Fiff	Sam	Environmental Manager:	PO Box 255 BLOEMFONTEIN 9300	sam.fiff@transnet.net
SENTECH					
Mr	Koegelenberg	Johan	Renewable Projects	Private Bag X06 Honeydew 2040	koegelenbergj@sentech.co.za
TELKOM					
Ms	van Zyl-Swart	Annette	Planner	PO Box 1025, Klerksdorp 2570	vzyla7@telkom.co.za
ENDANGERED WILDLIFE TRUST					

TITLE	SURNAME	NAME	POSITION	POSTAL ADDRESS	EMAIL ADDRESS
Mr	Leeuwner	Lourens	Renewable Energy Project	The Endangered Wildlife Trust, 86 Capricorn Drive, Capricorn Business Park Muizenberg CAPE TOWN	lourensl@ewt.org.za
WESSA					
Mr	Griffiths	Morgan	Environmental Governance Programme Manager	PO Box 12444 Central Hill Port Elizabeth 6006	morgan.griffiths@wessa.co.za info@wessa.co.za wessanc@yahoo.com
BIRDLIFE SOUTH AFRICA					
Mr	Gear	Simon	Policy and Advocacy Manager	PO Box 515 RANDBURG 2125	advocacy@birdlife.org.za
SQUARE KILOMETRE ARRAY					
Dr	Tiplady	Adriaan	Manager: Site Categorisation	PO Box 522 SAXONWOLD 2132	atiplady@ska.ac.za
DEPARTMENT OF ENVIRONMENTAL AFFAIRS BIODIVERSITY					
Mr	Lekota	Seoka		Private Bag X447 Pretoria 0001	slekota@environment.gov.za
Ms	Rabothata	Mmatlala		Private Bag X447 Pretoria 0001	slekotamrabothata@environment.gov.za



Appendix E6

CORRESPONDENCE AND MEETING MINUTES



SiVEST Environmental (Pty) Ltd

Contact: Lynsey Rimbault

Address: PO Box 2921
51 Wessels Road
Rivonia 2128

Tel: 011 798 0600

Fax: 011 803 7272

E-mail: lynseyr@sivest.co.za

**Environmental Impact Assessments (EIA)
for the Two Tlisitseng Solar Photovoltaic
(PV) Energy Facilities, and Basic
Assessments for the Associated
Substations and Power Lines, near
Lichtenburg, North West Province**

**Feedback of the
Public Meeting**

**Held on
Monday 14 March 2016 at 18h00**

**Lichtenburg Town Hall, Nelson Mandela Drive,
Lichtenburg.**

North West Province

PUBLIC MEETING

Venue: Lichtenburg Town Hall, Cnr Nelson Mandela Drive, Lichtenburg
Date: Monday, 14 March 2016
Time: 18h00 – 19h00

Except for the representatives from SiVEST, Zitholele and BioTherm Energy, no one attended the Focus Group Meeting (FGM). A copy of the Attendance Record is attached as **Annexure A**. All Interested and Affected Parties on the project database were invited to the workshop in writing (email notification, **Appendix C**).

Due to the lack of attendees nothing was presented at the meeting, however, a copy of the presentation (as prepared) is attached as **Annexure B**.

Annexure A

ATTENDANCE RECORD

**TLISITSENG SOLAR PROJECTS: PUBLIC MEETING
ATTENDANCE RECORD**

First Name	Last Name	Company
Irene	Bezuidenhout	BioTherm Energy
Siphelele	Dunga	BioTherm Energy
Thulani	Koom	BioTherm Energy
Daniel	Lowings	BioTherm Energy
Lynsey	Rimbault	SiVEST
Stephan	Jacobs	SiVEST
Nicolene	Venter	Zitholele Consulting

Annexure B

COPY OF PRESENTATION

ENVIRONMENTAL IMPACT ASSESSMENTS FOR THE TWO TLISITSENG SOLAR PHOTOVOLTAIC ENERGY FACILITIES, AND BASIC ASSESSMENTS FOR THE ASSOCIATED SUBSTATIONS AND POWER LINES, NEAR LICHTENBURG, NORTH WEST PROVINCE

DEA Ref. No.: TLISITSENG PV SOLAR 1: 14/12/16/3/3/2/889
 TLISITSENG PV SOLAR 2: 14/12/16/3/3/2/890
 TLISITSENG 1 SUBSTATION AND POWER LINE: To be confirmed
 TLISITSENG 2 SUBSTATION AND POWER LINE: To be confirmed

A PROFESSIONAL TEAM DELIVERING CREATIVE PROJECT SOLUTIONS

SIVEST

Consulting Engineers • Project Managers • Environmental Consultants • Town and Regional Planners

PUBLIC MEETING

PRESENTATION DATE: 14 March 2016

1

AGENDA

SIVEST

- Welcome, introduction and apologies
- Purpose and conduct of meeting
- Background to the proposed development
- Environmental process followed and findings
- Discussion session
- Closure

2

CONDUCT OF MEETING

SIVEST

- Focus on issues relating to the EIAs/BAs
- Equal participation
- Identify yourselves
- Recorder
- Cell phone etiquette

3

PURPOSE OF MEETING

SIVEST

- To provide an overview of the proposed project
- To provide feedback on the findings as documented in EIA phase and BA specialist reports
- Provide an opportunity to raise comments and/or concerns regarding the proposed project
- To record comments, issues and concerns raised

4

PROJECT OVERVIEW

SIVEST

5

PROJECT OVERVIEW

SIVEST

- **What does the proposed development entail?**
 - Construction of Tlisitseng 1 and Tlisitseng 2 Solar Photovoltaic (PV) energy facilities, each with a maximum generation capacity of 75MW.
 - Including associated infrastructure for each facility
 - New onsite substation
 - Access road upgrades
 - Construction laydown area
 - Admin and warehouse building
 - Tlisitseng 1 and Tlisitseng 2 substations and 132kV power lines to connect the proposed substation to the existing Watershed MTS
- **Why is the project being proposed?**
 - To generate electricity to feed into the national grid
 - Promote use of renewable energy
 - To help meet future energy consumption requirements

6

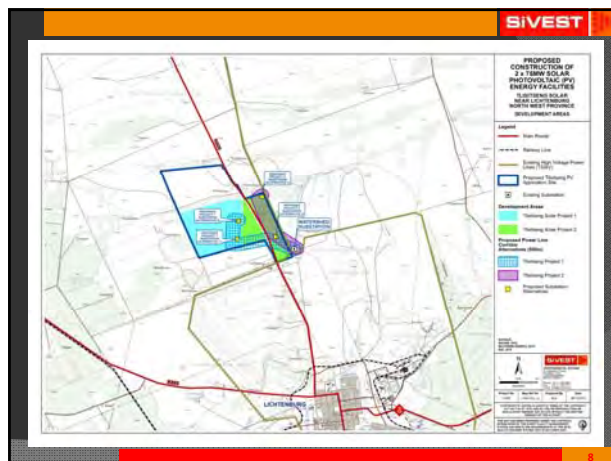
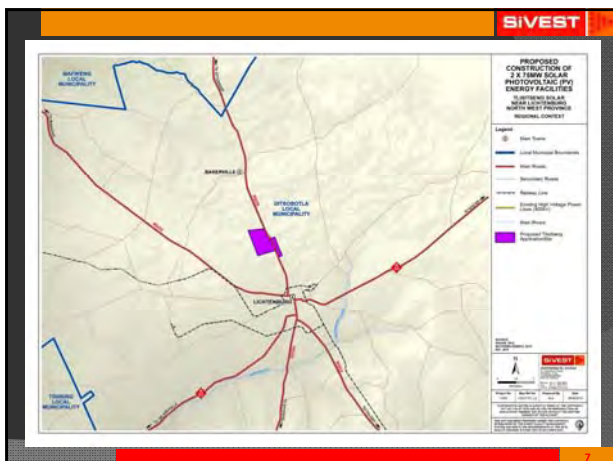

PROJECT OVERVIEW

- Who is the independent EAP?**
 - SIVEST SA
- Why undertake an EIA / BA?**
 - Legal requirement
 - Consider environmental impacts and mitigation measures
 - Provide stakeholders/I&APs the opportunity to participate
- Who is the applicant?**
 - BioTherm Energy
- Who is the decision-making authority?**
 - Department of Environmental Affairs (DEA)

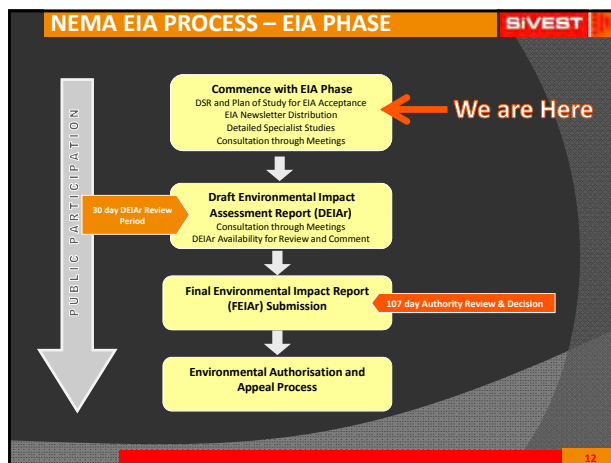
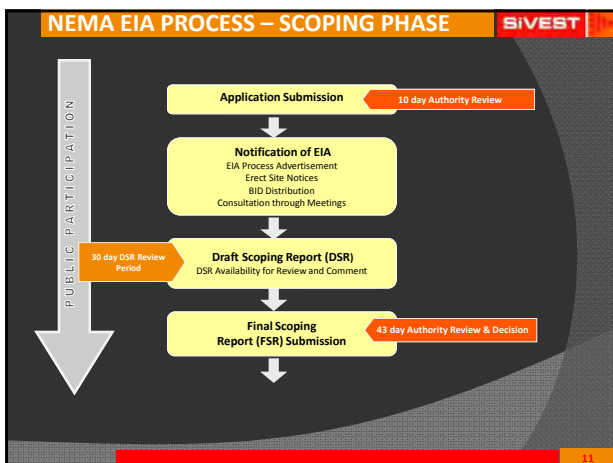

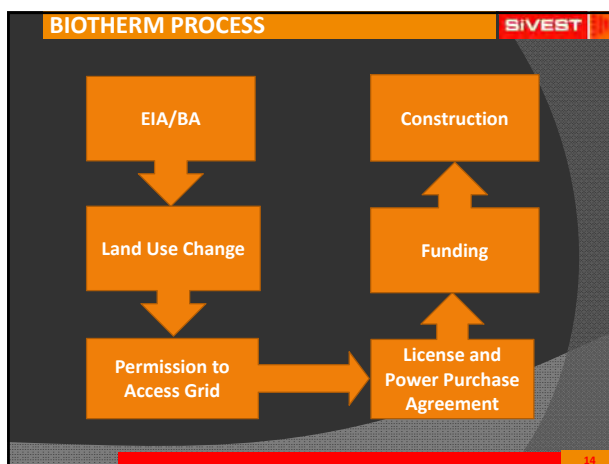
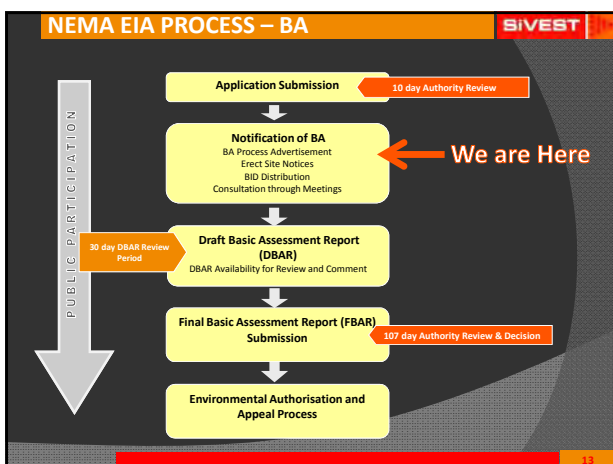

ENVIRONMENTAL FINDINGS

- ### ENVIRONMENTAL FINDINGS
- **EIA phase / BA underway**
 - Rating of significance of impacts
 - Compliance with Equator Principles
 - Compliance with all National legislation
 - Comparative assessment of on site alternatives
 - Environmental Management Programme
 - **Environmental aspects being assessed**
 - Biodiversity (flora and fauna)
 - Avifauna
 - Surface Water
 - Soils and Agricultural Potential
 - Visual
 - Heritage and Palaeontology
 - Socio-economic

BIODIVERSITY

	Tlitseng PV 1	Tlitseng PV 2	Tlitseng 1 Substation and Power Line	Tlitseng 2 Substation and Power Line
General Findings	<ul style="list-style-type: none"> • Vegetation (Carletonville Dolomite Grassland) is classified as Vulnerable, but has a wide distribution and extent, therefore considered to have moderately high conservation value • However, Provincial Biodiversity Conservation Assessment identifies Critical Biodiversity Areas and Ecological Support Areas → buffer areas for pans, and dolomite aquifer recharge zone. • Potential presence of: <ul style="list-style-type: none"> • 4 plant species of concern, the bulbs, <i>Boophone disticha</i> and <i>Crinum macowanii</i>, the succulent herb, <i>Brachystelma incanum</i>, and the herb, <i>Cleome conrathii</i>. • 1 protected plant species, <i>Harpagophytum procumbens</i>. • 3 protected tree species, <i>Acacia erioloba</i>, <i>Combretum imberbe</i> and <i>Boscia albitrunca</i>. The tree <i>Acacia erioloba</i> occurs in large numbers on site. • Brown Hyena, Honey badger, Southern African Hedgehog, White-tailed Rat, Giant Bullfrog. 			
Mitigation	Undertaking a botanical walk-through survey, search-and-rescue for any appropriate species, obtaining permits for any protected species.			
	Some issues related to the ecology of the site could result in potentially significant impacts but the seriousness of these impacts is not considered to be high.			

AVIFAUNA

	Tlitseng PV 1	Tlitseng PV 2	Tlitseng 1 Substation and Power Line	Tlitseng 2 Substation and Power Line
General Findings	<ul style="list-style-type: none"> • The projects are located in the Grassland avifaunal endemic region which has the fourth highest number of endemic bird species in southern Africa. • An estimated 284 species could potentially occur at the core study area and immediate surroundings (including the Lichtenburg Game Breeding Centre and wetland areas south-east of the project). Of these, 21 are South African Red Data species, 12 are southern African endemics and 21 are near-endemics. • The application site should therefore be regarded as moderately sensitive. • Highly sensitive areas are: surface water (boreholes) and high voltage lines which are used for roosting by Cape and White-backed Vultures. • Beyond the core study area, high voltage lines, a vulture restaurant, and wetlands and dams are potential high sensitive areas 			
Mitigation	No fatal flaws identified thus far, and the proposed development could therefore be authorised, provided all proposed mitigation measures are implemented.			
	Monitoring is ongoing and in depth statistical analyses will be performed on the full dataset after the monitoring has been completed.			

SURFACE WATER				
	Tlitseng PV 1	Tlitseng PV 2	Tlitseng 1 Substation and Power Line	Tlitseng 2 Substation and Power Line
General Findings	<ul style="list-style-type: none"> Vaal Primary Catchment (C31A quaternary catchment); Lower Vaal Water Management Area Depression wetland on greater application site has small chance of being indirectly affected by the proposed development. 			
	No pan wetlands would be directly affected.	One depression wetland could be directly affected.	No pan wetlands would be directly affected.	One depression wetland could be directly affected.
Mitigation	Preventing loss of wetland habitat, increased run-off, erosion and sedimentation			

SOILS AND AGRICULTURAL POTENTIAL				
	Tlitseng PV 1	Tlitseng PV 2	Tlitseng 1 Substation and Power Line	Tlitseng 2 Substation and Power Line
General Findings	<ul style="list-style-type: none"> Soils in the vicinity of the project were generally shallow to very shallow, however, some areas of deeper red soils, which will have a higher agricultural potential, can also occur. The soils are reddish-brown to brown, and belong to the Mispah, Glenrosa and Hutton soil forms This part of North West is well suited for grazing but here the grazing capacity is relatively low, around 12 ha/large stock unit Despite the dominance of shallow soils in the area, areas of cultivation on the deeper soils can be seen in the vicinity, including various centre pivot fields. 			
	At one point red Hutton soil of approximately 1 000 mm deep was observed.	At several points, the soil was seen to be deep (>750 mm), but these points were generally isolated.	Although there are deeper soils in the vicinity there is no evidence of cultivation along the rest of the corridor.	Although there are deeper soils that were observed in places, there is no evidence of cultivation along the rest of the corridor
Mitigation	Due to low agricultural potential, little or no mitigation measures are required. The footprint of the development should be kept to a minimum, so that at least the effect on grazing land for livestock is reduced.			

VISUAL				
	Tlitseng PV 1	Tlitseng PV 2	Tlitseng 1 Substation and Power Line	Tlitseng 2 Substation and Power Line
General Findings	<ul style="list-style-type: none"> Study area has a natural visual character, with a rural or pastoral component. Not generally valued for its tourism significance and is rated as having a low visual sensitivity. The R505 main road is considered to be a visually sensitive road and the relatively high volumes of motorists would be visually exposed to the project. Several farmsteads are regarded as potentially sensitive visual receptors. 			
	One sensitive receptor is present in the study area, namely the Lichtenburg Game Breeding Centre. This visually sensitive receptor was used as a tourism facility.	Two sensitive receptors are present in the study area, namely the Game Breeding Centre and the Lichtenburg Vakansie Oord which is used as a tourism facility.		
Mitigation	Minimise vegetation clearing and rehabilitate cleared areas as soon as possible. Ensure that dust suppression techniques are implemented. Light fittings for security at night should reflect the light toward the ground and prevent light spill.			
<p style="text-align: center;">Low visual impact during construction, Medium-visual impact during operation</p>				

HERITAGE AND PALAEOANTHROPOLOGY				
	Tlitseng PV 1	Tlitseng PV 2	Tlitseng 1 Substation and Power Line	Tlitseng 2 Substation and Power Line
General Findings	<ul style="list-style-type: none"> Two Stone Age sites were found, both of low significance Five historical structures were located, the age of which has not been determined, most are likely older than 60 years. An informal cemetery of approx. 60 graves is located at the eastern side of the application site. Micro-stromatolites and possible sites with cave breccia have been identified. 			
			Two historical structures were located, and are not significant.	
	Several arbitrary finds of dolomite and chert with significantly well-defined stromatolites as well as a few potential sites with either associated sinkholes or cave breccias were recorded.			
Mitigation	Sensitive sites will require mitigation work, including destruction permits in terms of section 34 of the NHRA. A 50m buffer must be provided around the cemetery, alternatively a grave relocation process will need to occur			
<p style="text-align: center;">The overall impact on heritage resources is acceptable, mitigation measures address any impacts on heritage</p>				

SOCIO-ECONOMIC				
	Tlitseng PV 1	Tlitseng PV 2	Tlitseng 1 Substation and Power Line	Tlitseng 2 Substation and Power Line
General Findings	<ul style="list-style-type: none"> Positive and negative impacts → including skills development and employment creation, but also change in sense of place among others. The significance of the possible positive impacts of the proposed development outweighs the negative impacts. The project would generate positive socio-economic returns for the local economy and its community and should be considered for implementation 			
	The directly impacted land owner has indicated that alternative land can be acquired, to allow him to continue the current levels of agriculture production.		Some land owners have objected due to the possible visual impact.	
Mitigation	Mitigation measures should be implemented to maximise the benefit to the local community.			
	Care should be taken not to affect the supply of water extracted from boreholes on nearby farms.		It is recommended that the corridor be shifted to remain within Portion 25 of Farm Houthaalboom 31.	
	The issues of safety and livestock theft should be addressed.			

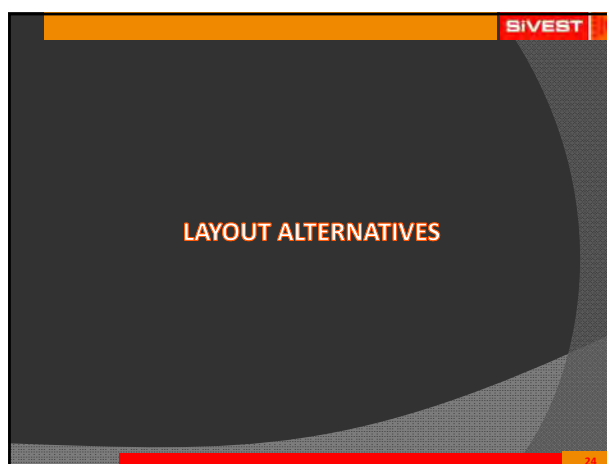

LAYOUT ALTERNATIVES SIVEST

- Layout alternatives will be presented in the DEIARs and DBARs.
- Design to incorporate specialist findings and stakeholder input.

25

PUBLIC PARTICIPATION

SIVEST

26

PUBLIC PARTICIPATION – SCOPING PHASE SIVEST

ONGOING I&AP IDENTIFICATION & CONSULTATION

- Site Notices and Stakeholder Consultation**
December 2015
- BID Comment Period**
December 2015 – January 2016
- EIA Process Advertisement**
January 2016
- DSR Availability**
DSR Review Period: 11 January 2016 – 09 February 2016
- FSR Availability and Submission to DEA**
February 2016

27

PUBLIC PARTICIPATION – EIA PHASE AND BA SIVEST

ONGOING I&AP IDENTIFICATION & CONSULTATION

- Environmental Meetings**
14 March 2016
- DEA Acceptance of FSR and EIA Plan of Study**
April 2016
- EIA Newsletter**
April 2016
- DEIAR and DBAR Availability**
April 2016
- FEIAR and FBAR Availability and Submission to DEA**
June 2016
- Notify I&APs of EA and Appeal Process**
September/October 2016

28

DISCUSSION

SIVEST

29

CONTACT DETAILS SIVEST

SIVEST Environmental Division
 PO Box 2921
 Rivonia
 2128

Lynsey Rimbault/ Nicolene Venter
 ☎ Phone: (011) 798 0600
 ☎ Fax: (011) 803 7272
 ✉ E-mail: lynseyr@sivest.co.za / nicolenev@zitholele.co.za
 🌐 Website: www.sivest.co.za

30

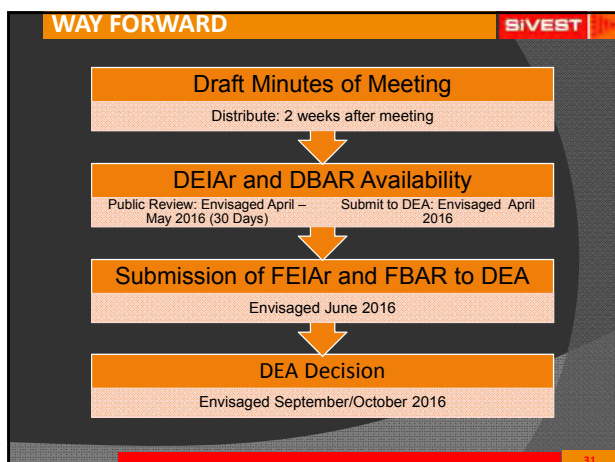

Annexure C

PROOF OF NOTIFICATION

Hlengiwe Ntuli

From: Hlengiwe Ntuli
Sent: 07 March 2016 06:10 PM
Cc: Rebecca Thomas; Lynsey Rimbault; 'nicolenev@zitholele.co.za'
Subject: Tlisitseng PV Public Meeting Invitation
Attachments: 13303 Tlisitseng PM Agenda Rev 1_7March2016 RT_combined.pdf; 13303 Tlisitseng PM Registration Form_Rev 1_7March2016 RT_combined.pdf

Tracking:	Recipient	Delivery	Read
	Rebecca Thomas	Delivered: 2016/03/07 06:10 PM	Read: 2016/03/08 09:32 AM
	Lynsey Rimbault	Delivered: 2016/03/07 06:10 PM	
	'nicolenev@zitholele.co.za'		
	'Neil Faber'		
	'Mariette Steynberg'		
	'Kobus Visser'		
	'Simphiwe Masilela'		
	'Johanna Morobane'		
	'Simon Gear'		
	'Godfrey Samore'		
	'Mashudu Marubini'		
	'Anneliza Collett'		
	'Thoko Buthelezi'		
	'Pheladi Masipa'		
	'Lerato April'		
	'Seoka Lekota'		
	'Mmatlala Rabothata'		
	'Pieter Swart'		
	'Doris Maumela'		
	'Lesego Holele'		
	'Pogiso Maitshotlo'		
	'J Molefe'		
	'KRJ Zandamela'		
	'John Geeringh'		
	'Lourens Leeuwner'		
	'Ferdinand Hartzenberg'		
	'JH Nel'		
	'G Pieterse'		
	'Wessel Wessels'		
	'Jan Steunman'		
	'Gysbert Goedhals'		
	'J Hechter'		
	'Marlaine Andersen'		
	'Mpho Phiri'		
	'M W Moholatsi'		
	'Lehlohonolo March'		

Recipient	Delivery	Read
'Nono Dince'		
'Yoliswa Sechoaro'		
'Alfred Mafune'		
'Matshediso Mahlaku'		
'Tebogo Sethosa'		
'Bonolo Mohlakoana'		
'SM Matsheka'		
'Lizell Stroh'		
'Harry Roberts'		
'J Oliver'		
'Shaun Dyers'		
'Johan Koegelenberg'		
'Chris Nthaudi'		
'Annette Van Zyl-Swart'		
'Sam Fiff'		
'Suzanne Erasmus'		
'Morgan Griffiths'		

***** Please note that this email was sent from a NO REPLY email address. Please do not reply to this address as it is an unmonitored email account. *****

Dear Interested and Affected Party,

ENVIRONMENTAL IMPACT ASSESSMENT (EIA) AND ENVIRONMENTAL MANAGEMENT PROGRAMME (EMPr) FOR THE TWO TLISITSENG SOLAR PHOTOVOLTAIC (PV) ENERGY FACILITIES, AND BASIC ASSESSMENTS (BA) FOR THE ASSOCIATED SUBSTATIONS AND POWER LINES, NEAR LICHTENBURG, NORTH WEST PROVINCE

DEA Ref. TLISITSENG PV SOLAR 1: 14/12/16/3/3/2/889
 TLISITSENG PV SOLAR 2: 14/12/16/3/3/2/890 TLISITSENG 1 SUBSTATION AND POWER LINE: To be confirmed
 TLISITSENG 2 SUBSTATION AND POWER LINE: To be confirmed

- INVITATION TO PUBLIC MEETING

We would like to take this opportunity to invite you to attend the Public Meeting that will be held for the above-mentioned proposed project on:

DATE	TIMES	VENUES
Monday, 14 March 2016	Starts at: 18h00 Registration from: 17h45	Lichtenburg Town Hall / Soepe Hall, on Nelson Mandela Drive, Lichtenburg

To ensure that sufficient seating is provided at the venue, we kindly request that you complete the attached Registration Form and return it to the Public Participation team on or before Thursday, 10 March 2016.

The purpose of the Public Meeting is outlined in the attached draft agenda.

Your input into this EIA process is highly valued as it will help identify, and if required address, any environmental impacts that may be associated with this proposed project during the Scoping phase.

We encourage you to attend and participate in the Public Meeting and thank you in anticipation for your active and meaningful contribution to the EIA process.

Beste Belangstellende en/of Geaffekteerde Party,

OMGEWINGSIMPAKEVALUERING (OIE) EN OMGEWINGSBESTUURSPROGRAM (OBPr) VIR DIE VOORGESTELDE ONTWIKKELING VAN DIE TWEE (2) TLISITSENG 75MW FOTOVOLTAÏESE (FV) SONKRAGAAANLEGTE, EN BASIESE EVALUERING (BE) VIR DIE GEASSOSIEERDE 132KV KRAGLYNE NABY LICHTENBURG, NOORDWES PROVINSIE

DO Verw. No. TLISITSENG PV SOLAR 1: 14/12/16/3/3/2/889

TLISITSENG PV SOLAR 2: 14/12/16/3/3/2/890 TLISITSENG 1 SUBSTATION AND POWER LINE: Ter bevestiging

TLISITSENG 2 SUBSTATION AND POWER LINE: Ter bevestiging

• UITNODIGING NA PUBLIEKEVERGADERING

Ons maak graag van hierdie geleentheid gebruik om u uit te nooi om die Publiekevergadering wat vir die bogenoemde voorgestelde projek gehou word op:

DATUM	TYD	PLEK
Maandag, 14 Maart 2016	Begin om: 18h00 Registrasie vanaf: 17h45	Lichtenburg Town Hall / Soepee Hall, Nelson Mandela Drive, Lichtenburg

Om te verseker dat ons voorsiening maak vir alle teenwoordiges, versoek ons u vriendelik om die ingeslote Registrasievorm te voltooi en aan die Openbare Deelname span te stuur voor of op Donderdag, 10 Maart 2016.

Die doel van die Publiekevergadering is vervat in die ingeslote konsep agenda.

U insette in die OIS-proses word hoog op prys gestel aangesien dit sal bydrae tot die identifisering van, en indien nodig die gepaardgaande ondersoek tydens die Bestekopnamefase, van enige omgewingsimpakte wat met hierdie voorgestelde projek geassosieer mag word.

Ons moedig u bywoning en deelname by die Publiekevergadering aan en dank u byvoorbaat vir u aktiewe en betekenisvolle bydrae tot die OIS-proses.

REBECCA THOMAS (B.Sc Env. Sc.; PDM Business Management) Senior Environmental Scientist SiVEST Environmental Division

SiVEST is a Level 3 BBBEE Contributor

direct +27 11 798 0634 tel +27 11 798 0600 fax +27 11 803 7272 cell +27 82 302 9010

email rebeccat@sivest.co.za website www.sivest.co.za

Consulting Engineers - Project Managers - Environmental Consultants - Town and Regional Planners Durban - Johannesburg - Pietermaritzburg - Richards Bay - Ladysmith - Cape Town - Harare (Zimbabwe)

SiVEST is a Level 3 BBBEE Contributor

Direct +27 11 798 0691 Tel +27 11 798 0600 fax +27 11 803 7272 cell +27 72 779 4899

email shaunt@sivest.co.za website www.sivest.co.za

Consulting Engineers - Project Managers - Environmental Consultants - Town and Regional Planners Durban - Johannesburg - Pietermaritzburg - Richards Bay - Ladysmith - Cape Town - Harare (Zimbabwe)

Your reference

Our reference 13303

Date 7 March 2016

Dear Interested and Affected Party,

ENVIRONMENTAL IMPACT ASSESSMENT (EIA) AND ENVIRONMENTAL MANAGEMENT PROGRAMME (EMPr) FOR THE TWO TLISITSENG SOLAR PHOTOVOLTAIC (PV) ENERGY FACILITIES, AND BASIC ASSESSMENTS (BA) FOR THE ASSOCIATED SUBSTATIONS AND POWER LINES, NEAR LICHTENBURG, NORTH WEST PROVINCE

DEA Ref. TLISITSENG PV SOLAR 1: 14/12/16/3/3/2/889
TLISITSENG PV SOLAR 2: 14/12/16/3/3/2/890
TLISITSENG 1 SUBSTATION AND POWER LINE: To be confirmed
TLISITSENG 2 SUBSTATION AND POWER LINE: To be confirmed

• **INVITATION TO PUBLIC MEETING**

We would like to take this opportunity to invite you to attend the Public Meeting that will be held for the above-mentioned proposed project on:

DATE	TIMES	VENUES
Monday, 14 March 2016	Starts at: 18h00 Registration from: 17h45	Lichtenburg Town Hall / Soepee Hall, on Nelson Mandela Drive, Lichtenburg

To ensure that sufficient seating is provided at the venue, we kindly request that you complete the attached Registration Form and return it to the Public Participation team on or before **Thursday, 10 March 2016**.

The purpose of the Public Meeting is outlined in the attached draft agenda.

Your input into this EIA process is highly valued as it will help identify, and if required address, any environmental impacts that may be associated with this proposed project during the Scoping phase.

We encourage you to attend and participate in the Public Meeting and thank you in anticipation for your active and meaningful contribution to the EIA process.

Yours sincerely,



Rebecca Thomas
Environmental Practitioner
SIVEST Environmental Division

Documents attached: Draft Agenda
Registration Form

Your reference

Our reference 13303

Date 7 Maart 2016

Beste Belangstellende en/of Geaffekteerde Party,

OMGEWINGSIMPAAKEVALUERING (OIE) EN OMGEWINGSBESTUURSPROGRAM (OBPr) VIR DIE VOORGESTELDE ONTWIKKELING VAN DIE TWEE (2) TLISITSENG 75MW FOTOVOLTAÏESE (FV) SONKRAGAAANLEGTE, EN BASIESE EVALUERING (BE) VIR DIE GEASSOSIEERDE 132KV KRAGLYNE NABY LICHTENBURG, NOORDWES PROVINSIE

**DO Verw. No. TLISITSENG PV SOLAR 1: 14/12/16/3/3/2/889
TLISITSENG PV SOLAR 2: 14/12/16/3/3/2/890
TLISITSENG 1 SUBSTATION AND POWER LINE: Ter bevestiging
TLISITSENG 2 SUBSTATION AND POWER LINE: Ter bevestiging**

• **UITNODIGING NA PUBLIEKEVERGADERING**

Ons maak graag van hierdie geleentheid gebruik om u uit te nooi om die Publiekevergadering wat vir die bogenoemde voorgestelde projek gehou word op:

DATUM	TYD	PLEK
Maandag, 14 Maart 2016	Begin om: 18h00 Registrasie vanaf: 17h45	Lichtenburg Town Hall / Soepee Hall, Nelson Mandela Drive, Lichtenburg

Om te verseker dat ons voorsiening maak vir alle teenwoordiges, versoek ons u vriendelik om die ingeslote Registrasievorm te voltooi en aan die Openbare Deelname span te stuur voor of op Donderdag, 10 Maart 2016.

Die doel van die Publiekevergadering is vervat in die ingeslote konsep agenda.

U insette in die OIS-proses word hoog op prys gestel aangesien dit sal bydrae tot die identifisering van, en indien nodig die gepaardgaande ondersoek tydens die Bestekopnamefase, van enige omgewingsimpakte wat met hierdie voorgestelde projek geassosieer mag word.

Ons moedig u bywoning en deelname by die Publiekevergadering aan en dank u byvoorbaat vir u aktiewe en betekenisvolle bydrae tot die OIS-proses.

Vriendelike groete,



Rebecca Thomas
Omgewingskonsultant
SIVEST Omgewingsafdeling

Ingeslote Dokumente: Konsep Agenda
Registrasievorm

SIVEST



**ENVIRONMENTAL IMPACT
ASSESSMENTS (EIAs) FOR THE TWO
TLISITSENG SOLAR PHOTOVOLTAIC
(PV) ENERGY FACILITIES, AND BASIC
ASSESSMENTS FOR THE
ASSOCIATED SUBSTATIONS AND
POWER LINES, NEAR LICHTENBURG,
NORTH WEST PROVINCE**

**MINUTES OF THE
FOCUS GROUP MEETING**

Landowners

**Held on
Monday, 14 March 2016 at 11h00
Rafters Bushpub & Sports Bar, Lichtenburg**

North West Province

SiVEST Environmental (Pty) Ltd

Contact: Lynsey Rimbault

Address: PO Box 2921
51 Wessels Road
Rivonia 2128

Tel: 011 798 0600

Fax: 011 803 7272

E-mail: lynseyr@sivest.co.za

Draft Minutes prepared by:

Lynsey Rimbault

Please address any comments to Lynsey Rimbault at the above address

TABLE OF CONTENTS

1	WELCOME, INTRODUCTIONS	1
2	MEETING ATTENDEES	1
3	PURPOSE OF THE MEETING.....	1
4	PROJECT CONTEXT AND OVERVIEW	1
5	DISCUSSION SESSION AND QUESTIONS	1
6	CLOSURE AND WAY FORWARD	2

YOUR COMMENTS ON THE DRAFT MINUTES

Your comments on these draft Minutes will be appreciated. In particular, we request you to verify that your comments during the meeting have been minuted correctly. **It is important to note that the draft Minutes are not verbatim and any comments and questions raised by the technical specialists and the project proponent are not included in the discussion document.** Please address your comments, in writing (preferably email) to Lynsey Rimbault at the address given on the cover page on or before **Wednesday 11 May 2016**.

FOCUS GROUP MEETING

Venue: Rafters Bushpub & Sports Bar, Lichtenburg
Date: Monday, 14 March 2016
Time: 11h00 – 12h00

1 WELCOME, INTRODUCTIONS

Nicolene Venter welcomed everyone who attended the Focus Group Meeting (FGM) and thanked them for attending. She then proceeded to discuss the agenda of the meeting. Nicolene introduced herself and noted that Zitholele Consultants have been appointed by SiVEST to assist with the Public Participation Process (PPP) for the proposed projects. Nicolene asked if the representatives from SiVEST and BioTherm Energy who were present at the meeting could please introduce themselves and explain their roles with regards to the proposed projects.

2 MEETING ATTENDEES

The Focus Group Meeting (FGM) was attended by representatives from SiVEST, Zitholele, BioTherm as well as local landowners. A copy of the Attendance Record is attached as **Annexure A**.

3 PURPOSE OF THE MEETING

Nicolene Venter informed the attendees that the purpose of the FGM was to:

- To provide an overview of the proposed project;
- To provide feedback on the findings as documented in the EIA phase specialist reports;
- To provide an opportunity to raise comments and/or concerns regarding the proposed project; and
- To record comments, issues and concerns raised.

4 PROJECT CONTEXT AND OVERVIEW

Lynsey Rimbault presented an overview of the proposed project explaining the background to the project, what the project would entail, what the EIA and BA process entails, and the current status of the EIA and BA process.

Refer to **Annexure B** for a copy of the presentation.

5 DISCUSSION SESSION AND QUESTIONS

Please refer to **Annexure C** for the discussion session.

6 CLOSURE AND WAY FORWARD

Nicolene Venter closed the meeting at approximately 12h30. She informed the attendees that the FGM minutes, presentation, and attendance record would be forwarded to everyone who attended the meeting.

Annexure A

ATTENDANCE RECORD

TLISITSENG SOLAR PROJECTS: LANDOWNER FOCUS GROUP MEETING ATTENDANCE RECORD		
First Name	Last Name	Company
Irene	Bezuidenhout	BioTherm Energy
Siphelele	Dunga	BioTherm Energy
Thulani	Koom	BioTherm Energy
Daniel	Lowings	BioTherm Energy
Jackie	Hechter	
Fazel	Yarihawa	
Lynsey	Rimbault	SiVEST
Stephan	Jacobs	SiVEST
Nicolene	Venter	Zitholele Consulting

Annexure B

COPY OF PRESENTATION

ENVIRONMENTAL IMPACT ASSESSMENTS FOR THE TWO TLISITSENG SOLAR PHOTOVOLTAIC ENERGY FACILITIES, AND BASIC ASSESSMENTS FOR THE ASSOCIATED SUBSTATIONS AND POWER LINES, NEAR LICHTENBURG, NORTH WEST PROVINCE

DEA Ref. No.: TLISITSENG PV SOLAR 1: 14/12/16/3/3/2/889
 TLISITSENG PV SOLAR 2: 14/12/16/3/3/2/890
 TLISITSENG 1 SUBSTATION AND POWER LINE: To be confirmed
 TLISITSENG 2 SUBSTATION AND POWER LINE: To be confirmed

A PROFESSIONAL TEAM DELIVERING CREATIVE PROJECT SOLUTIONS

Consulting Engineers • Project Managers • Environmental Consultants • Town and Regional Planners

FOCUS GROUP MEETING

PRESENTATION DATE: 14 March 2016

1

AGENDA

SIVEST

- Welcome, introduction and apologies
- Purpose and conduct of meeting
- Background to the proposed development
- Environmental process followed and findings
- Discussion session
- Closure

2

PURPOSE OF MEETING

SIVEST

- To provide an overview of the proposed project
- To provide feedback on the findings as documented in EIA phase and BA specialist reports
- Provide an opportunity to raise comments and/or concerns regarding the proposed project
- To record comments, issues and concerns raised

3

PROJECT OVERVIEW

SIVEST

4

PROJECT OVERVIEW

SIVEST

- **What does the proposed development entail?**
 - Construction of Tlisitseng 1 and Tlisitseng 2 Solar Photovoltaic (PV) energy facilities, each with a maximum generation capacity of 75MW.
 - Including associated infrastructure for each facility
 - New onsite substation
 - Access road upgrades
 - Construction laydown area
 - Admin and warehouse building
 - Tlisitseng 1 and Tlisitseng 2 substations and 132kV power lines to connect the proposed substation to the existing Watershed MTS
- **Why is the project being proposed?**
 - To generate electricity to feed into the national grid
 - Promote use of renewable energy
 - To help meet future energy consumption requirements

5

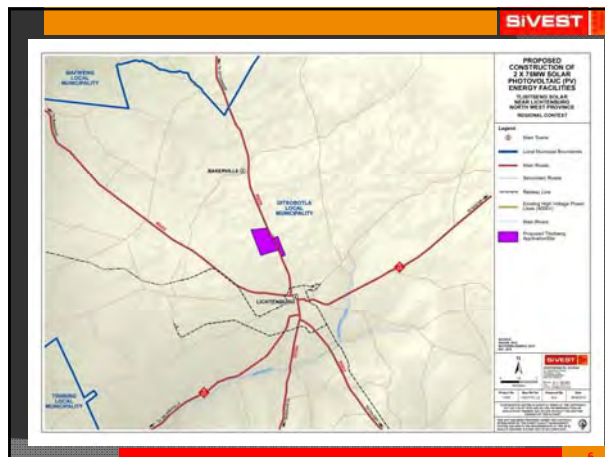

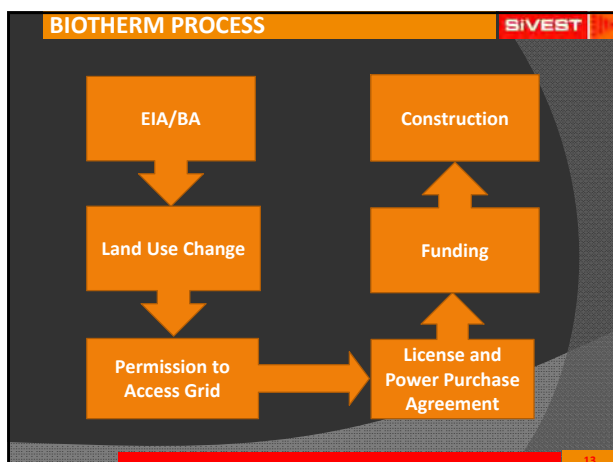

6



ENVIRONMENTAL FINDINGS



- ### ENVIRONMENTAL FINDINGS
- EIA phase / BA underway
 - Rating of significance of impacts
 - Compliance with Equator Principles
 - Compliance with all National legislation
 - Comparative assessment of on site alternatives
 - Environmental Management Programme
 - Environmental aspects being assessed
 - Biodiversity (flora and fauna)
 - Avifauna
 - Surface Water
 - Soils and Agricultural Potential
 - Visual
 - Heritage and Palaeontology
 - Socio-economic

BIODIVERSITY

	Tlitseng PV 1	Tlitseng PV 2	Tlitseng 1 Substation and Power Line	Tlitseng 2 Substation and Power Line
General Findings	<ul style="list-style-type: none"> • Vegetation (Carletonville Dolomite Grassland) is classified as Vulnerable, but has a wide distribution and extent, therefore considered to have moderately high conservation value • However, Provincial Biodiversity Conservation Assessment identifies Critical Biodiversity Areas and Ecological Support Areas → buffer areas for pans, and dolomite aquifer recharge zone. • Potential presence of: <ul style="list-style-type: none"> • 4 plant species of concern, the bulbs, <i>Boophone disticha</i> and <i>Crinum macowanii</i>, the succulent herb, <i>Brachystelma incanum</i>, and the herb, <i>Cleome conrathii</i>. • 1 protected plant species, <i>Harpagophytum procumbens</i>. • 3 protected tree species, <i>Acacia erioloba</i>, <i>Commersonia imberbe</i> and <i>Boscia albitrunca</i>. The tree <i>Acacia erioloba</i> occurs in large numbers on site. • Brown Hyaena, Honey badger, Southern African Hedgehog, White-tailed Rat, Giant Bullfrog. 			
Mitigation	Undertaking a botanical walk-through survey, search-and-rescue for any appropriate species, obtaining permits for any protected species.			
	 <p><i>Boophone disticha</i></p>		 <p><i>Acacia erioloba</i></p>	



Some issues related to the ecology of the site could result in potentially significant impacts but the seriousness of these impacts is not considered to be high.

AVIFAUNA



	Tlitseng PV 1	Tlitseng PV 2	Tlitseng 1 Substation and Power Line	Tlitseng 2 Substation and Power Line
General Findings	<ul style="list-style-type: none"> • The projects are located in the Grassland avifaunal endemic region which has the fourth highest number of endemic bird species in southern Africa. • An estimated 284 species could potentially occur at the core study area and immediate surroundings (including the Lichtenburg Game Breeding Centre and wetland areas south-east of the project). Of these, 21 are South African Red Data species, 12 are southern African endemics and 21 are near-endemics. • The application site should therefore be regarded as moderately sensitive. • Highly sensitive areas are: surface water (boreholes) and high voltage lines which are used for roosting by Cape and White-backed Vultures. • Beyond the core study area, high voltage lines, a vulture restaurant, and wetlands and dams are potential high sensitive areas 			
Mitigation	No fatal flaws identified thus far, and the proposed development could therefore be authorised, provided all proposed mitigation measures are implemented.			
	 <p>Northern Black Korhaan</p>		 <p>White-backed Vulture</p>	



Monitoring is ongoing and in depth statistical analyses will be performed on the full dataset after the monitoring has been completed.

SURFACE WATER

	Tlitseng PV 1	Tlitseng PV 2	Tlitseng 1 Substation and Power Line	Tlitseng 2 Substation and Power Line
General Findings	<ul style="list-style-type: none"> • Vaal Primary Catchment (C31A quaternary catchment); Lower Vaal Water Management Area • Depression wetland on greater application site has small chance of being indirectly affected by the proposed development. 			
	No pan wetlands would be directly affected.	One depression wetland could be directly affected.	No pan wetlands would be directly affected.	One depression wetland could be directly affected.
Mitigation	Preventing loss of wetland habitat, increased run-off, erosion and sedimentation			
				

SOILS AND AGRICULTURAL POTENTIAL				
	Tlitsitseng PV 1	Tlitsitseng PV 2	Tlitsitseng 1 Substation and Power Line	Tlitsitseng 2 Substation and Power Line
General Findings	<ul style="list-style-type: none"> Soils in the vicinity of the project were generally shallow to very shallow, however, some areas of deeper red soils, which will have a higher agricultural potential, can also occur. The soils are reddish-brown to brown, and belong to the Mispah, Glenrosa and Hutton soil forms This part of North West is well suited for grazing but here the grazing capacity is relatively low, around 12 ha/large stock unit Despite the dominance of shallow soils in the area, areas of cultivation on the deeper soils can be seen in the vicinity, including various centre pivot fields. 			
	At one point red Hutton soil of approximately 1 000 mm deep was observed.	At several points, the soil was seen to be deep (>750 mm), but these points were generally isolated.	Although there are deeper soils in the vicinity there is no evidence of cultivation along the rest of the corridor.	Although there are deeper soils that were observed in places, there is no evidence of cultivation along the rest of the corridor
Mitigation	Due to low agricultural potential, little or no mitigation measures are required. The footprint of the development should be kept to a minimum, so that at least the effect on grazing land for livestock is reduced.			

VISUAL				
	Tlitsitseng PV 1	Tlitsitseng PV 2	Tlitsitseng 1 Substation and Power Line	Tlitsitseng 2 Substation and Power Line
General Findings	<ul style="list-style-type: none"> Study area has a natural visual character, with a rural or pastoral component. Not generally valued for its tourism significance and is rated as having a low visual sensitivity. The R505 main road is considered to be a visually sensitive road and the relatively high volumes of motorists would be visually exposed to the project. Several farmsteads are regarded as potentially sensitive visual receptors. 			
	One sensitive receptor is present in the study area, namely the Lichtenburg Game Breeding Centre. This visually sensitive receptor was used as a tourism facility.		Two sensitive receptors are present in the study area, namely the Game Breeding Centre and the Lichtenburg Vakansie Oord which is used as a tourism facility.	
Mitigation	Minimise vegetation clearing and rehabilitate cleared areas as soon as possible. Ensure that dust suppression techniques are implemented. Light fittings for security at night should reflect the light toward the ground and prevent light spill.			
	 <p style="text-align: center;">Low visual impact during construction, Medium visual impact during operation</p> 			

HERITAGE AND PALAEOLOGY				
	Tlitsitseng PV 1	Tlitsitseng PV 2	Tlitsitseng 1 Substation and Power Line	Tlitsitseng 2 Substation and Power Line
General Findings	<ul style="list-style-type: none"> Two Stone Age sites were found, both of low significance Five historical structures were located, the age of which has not been determined, most are likely older than 60 years. An informal cemetery of approx. 60 graves is located at the eastern side of the application site. Micro-stromatolites and possible sites with cave breccia have been identified. 		<ul style="list-style-type: none"> Two historical structures were located, and are not significant. Several arbitrary finds of dolomite and chert with significantly well-defined stromatolites as well as a few potential sites with either associated sinkholes or cave breccias were recorded. 	
Mitigation	Sensitive sites will require mitigation work, including destruction permits in terms of section 34 of the NHRA. A 50m buffer must be provided around the cemetery, alternatively a grave relocation process will need to occur			
	 <p style="text-align: center;">The overall impact on heritage resources is acceptable, mitigation measures address any impacts on heritage.</p> 			

SOCIO-ECONOMIC				
	Tlitsitseng PV 1	Tlitsitseng PV 2	Tlitsitseng 1 Substation and Power Line	Tlitsitseng 2 Substation and Power Line
General Findings	<ul style="list-style-type: none"> Positive and negative impacts → including skills development and employment creation, but also change in sense of place among others. The significance of the possible positive impacts of the proposed development outweighs the negative impacts. The project would generate positive socio-economic returns for the local economy and its community and should be considered for implementation The directly impacted land owner has indicated that alternative land can be acquired, to allow him to continue the current levels of agriculture production. 			
			Some land owners have objected due to the possible visual impact.	
Mitigation	<ul style="list-style-type: none"> Mitigation measures should be implemented to maximise the benefit to the local community. Care should be taken not to affect the supply of water extracted from boreholes on nearby farms. The issues of safety and livestock theft should be addressed. 			
			It is recommended that the corridor be shifted to remain within Portion 25 of Farm Houthaalboomem 31.	

LAYOUT ALTERNATIVES

- Layout alternatives will be presented in the DEIARs and DBARs.
- Design to incorporate specialist findings and stakeholder input.

PUBLIC PARTICIPATION

SIVEST

25

PUBLIC PARTICIPATION – SCOPING PHASE

SIVEST

ONGOING I&AP IDENTIFICATION & CONSULTATION

- Site Notices and Stakeholder Consultation
December 2015
- BID Comment Period
December 2015 – January 2016
- EIA Process Advertisement
January 2016
- DSR Availability
DSR Review Period: 11 January 2016 – 09 February 2016
- FSR Availability and Submission to DEA
February 2016

26

PUBLIC PARTICIPATION – EIA PHASE AND BA

SIVEST

ONGOING I&AP IDENTIFICATION & CONSULTATION

- Environmental Meetings
14 March 2016
- DEA Acceptance of FSR and EIA Plan of Study
April 2016
- EIA Newsletter
April 2016
- DEIAr and DBAR Availability
April 2016
- FEIAr and FBAR Availability and Submission to DEA
June 2016
- Notify I&APs of EA and Appeal Process
September/October 2016

27

DISCUSSION

SIVEST

28

CONTACT DETAILS

SIVEST

SIVEST Environmental Division
PO Box 2921
Rivonia
2128

Lynsey Rimbault/ Nicolene Venter
Phone: (011) 798 0600
Fax: (011) 803 7272
E-mail: lynseyr@sivest.co.za / nicolenev@zitholele.co.za
Website: www.sivest.co.za

29

WAY FORWARD

SIVEST

- Draft Minutes of Meeting
Distribute: 2 weeks after meeting
- DEIAr and DBAR Availability
Public Review: Envisaged April – May 2016 (30 Days) | Submit to DEA: Envisaged April 2016
- Submission of FEIAr and FBAR to DEA
Envisaged June 2016
- DEA Decision
Envisaged September/October 2016

30

Annexure C

DISCUSSION DOCUMENT

**OMGEWINGSIMPAKEVALUERINGS (OIEs) VIR DIE BEOOGDE ONTWIKKELING VAN DIE TWEE
(2) TLISITSENG 75MW FOTOVOLTAÏESE (FV) SONKRAGAAANLEGTE EN BASIESE
EVALUERINGS (BE's) VIR DIE GEPAARDGAANDE 1323kV KRAGLYNE NABY LICHTENBURG,
NOORDWES-PROVINSIE**

**ENVIRONMENTAL IMPACT ASSESSMENTS (EIAs) FOR THE PROPOSED DEVELOPMENT OF
THE TWO (2) 75MW TLISITSENG SOLAR PHOTOVOLTAIC (PV) ENERGY FACILITIES AND
BASIC ASSESSMENTS (BAs) FOR THE ASSOCIATED 132kV POWER LINES NEAR
LICHTENBURG, NORTH-WEST PROVINCE**

TLISITSEN SOLAR 1 – DO Verw.No./DEA Ref. No.: 14/12/16/3/3/2/889

TLISITSEN SOLAR 2 - DO Verw.No. /DEA Ref. No.: 14/12/16/3/3/2/890

TLISITSEN 1 KRAGLYN - DO Verw.No. /DEA Ref. No.: Moet aangekondig word/To be announced

TLISITSEN 1 KRAGLYN - DO Verw.No. /DEA Ref. No.: Moet aangekondig word/To be announced

**KONSEP BESPREKINGSKONFERENSIE
FOKUSGROEPVERGADERING: GRONDEIENAARS**

**DRAFT DISCUSSION DOCUMENT
FOCUS GROUP MEETING: LANDOWNERS**

Rafters Bos- en Sportskroeg, Elandsfonteinpad (af van R505) / Rafters Busch and Sports Bar, Elandsfontein Road
(off the R505), Lichtenburg

Maandag, 14 Maart 2016 om 11h00 / Monday, 14 March 2016 at 11h00

INHOUDSOPGAWE / TABLE OF CONTENT

1.	Avifauna Aanverwante Kommentaar/Kwessies – Related Comments/Concerns	1
2.	Water Aanverwante Kommentaar/Kwessies - Related Comments/Concerns	1
3.	Visuële Aanverwante Kommentaar/Kwessies – Visual Related Comments/Concerns	2
4.	Sosio- en Sosio-Ekonomiese Aanverwante Kommentaar/Kwessies – Social and Socio-economic Related Comments/Concerns.....	2
5.	Projek Aanverwante Kommentaar/Kwessies – Project Related Comments/Concerns	3
6.	Kraglyn Korridor Aanverwante Kommentaar/Kwessies – Power Line Corridor Related Comments/Concerns.....	4
7.	Kommunikasie Aanverwante Kommentaar/Kwessies - Communication Related Comments/Concerns	4

Kommentaar / kwessies is gekategoriseer volgens omgewingsimpak en daarna volgens teenwoordiger se VAN / Comments / concerns / issues have been categorised according to environmental impact and thereafter according to SURNAME.

Kommentaar / kwellinge / kwessies vasgelê is nie verbatim nie maar 'n opsomming van kommentaar / kwellinge / kwessies geopper.
The comments / concerns / issues captured are not verbatim, but a summary.

AFKORTINGS / ABBREVIATIONS:

DEIAr	Draft Environmental Impact Assessment Report	EMPr	Environmental Management Programme
OBP	Omgewingsbestuursprogram	OIE	Omgewingsimpakevaluering

Issue/Comment	Raised By & When	Response
1. Avifauna Aanverwante Kommentaal/Kwessies – Related Comments/Concerns		
<p>Die projekspan was ingelig dat die vestiging van 'n voël teëlplaas op die eiendom beplan word en die voorgestelde ontwikkeling kan 'n negatiewe impak op die voëls se teëlpotensiaal hê.</p> <p>Translation: The project team was informed that they are planning to establish a bird breeding farm on the property and that the proposed development could impact on the breeding potential of the birds.</p>	<p>HECTOR, Jackie Grondeienaar: Talene Landbouhoeve No1 & Eienaar: Rafters Bos- en Sportskroeg / Landowner: Talene Agricultural Holdings No 1 & Owner: Rafters Busch & Sports Bar</p>	<p>Dit is die verwagting dat die voorgestelde ontwikkeling nie 'n impak op die teëlvermoë van voëls sal hê nie, maar die kwessie sal aan die spesialis deurgegee word vir terugvoer. Lynsey Rimbault, Environmental Consultant, SiVEST</p> <p>Translation: It is anticipated that the proposed development would not have an impact on the breeding potential of birds. This concern will be forwarded to the specialist for a response.</p> <p>Post-meeting note: The concern was forwarded to the avifaunal specialist on the proposed project, who responded that given the nature of the proposed project no impact on the breeding potential of the captive birds is foreseen.</p>
2. Water Aanverwante Kommentaal/Kwessies - Related Comments/Concerns		
<p>Die projekspan was ingelig oor 'n vorige insident wat deur die eienaars van Talene Landbouhewes meegemaak het toe die eienaar van die plaas Houthaalbomen (voorgestelde ontwikkelingsterrein) om 'n waterlisensie aangedoen het vir besproeiing op die plaas. Die negatiewe impak was van so 'n aard dat van Talene Landbouhewes se boorgate opgedroog het en ook 'n groot finansiële verlies gelei het deurdat hulle nuwe boorgate moes sink om watervoorsiening na hul eiendomme te herstel. Na aanleiding van bogenoemde negatiewe ondervinding, was dit verneem waar wil BioTherm vandaan kry vir konstruksie asook die skoonmaak van die panele.</p> <p>Translation: The project was informed regarding a previous incident experienced by the owners of Talene Agricultural Holdings when the owner of the</p>	<p>YARIHAWA, Fazel, Grondeienaar: Talene Landbouhoeve No 4 / Landowner: Talene Agricultural Holdings No 4</p>	<p>Die projekspan neem kennis van Talene Landbouhewes se kwellinge en wantroue in die proses rakende waterkwessies. Nicolene Venter, Publieke Deelnamekonsultant, Zitholele Consulting</p> <p>Volgens huidige inligting tot BioTherm se beskikking is daar voldoende watervoorsiening op die voorgestelde terrein wat aan beidie die konstruksie en operasionele fase van die projek sal kan voorsien. Indien addisionele watervoorsiening nodig is, sal daar met die Ditsobotla Plaaslike Munisipaliteit kontak gemaak word. Irene Bezuidenhout, Omgewingsbestuurder, BioTherm Energy</p> <p>Translation:</p>

<p>farm Houthaalbomen (the site for the proposed development) applied for a water use license for irrigation on his farm.</p> <p>The negative impact thereof was so severe to the Talene Agricultural Holdings that their boreholes dried up and also resulted in huge financial impacts as they had to sink new boreholes to reinstate their water supply.</p> <p>Due to above-mentioned negative experience it was enquired where BioTherm will be sourcing their water requirements from during the construction and the cleaning of the panels.</p>		<p>The project team take note of Talene Agricultural Holdings' concerns and mistrust in the process followed for the water related matter.</p> <p>According to current information available to BioTherm, there is sufficient water supply at the site where the proposed project is located and would be sufficient for both the construction and operational phase of the project. Should additional water supply be needed, discussion will take place with Ditsobotla Local Municipality.</p>
3. Visuële Aanverwante Kommentaar/Kwessies – Visual Related Comments/Concerns		
<p>Kommer is uitgespreek oor die moontlike impak wat die ontwikkeling op hul bestaande besigheid sal hê. Besoekers kom na hul fasiliteit om uit die dorp / stad te kom en 'n rustige atmosfeer en natuurskoon te ervaar.</p> <p>Translation: Concern was expressed regarding the possible impact that the proposed development would have on their existing business. Patrons visit their establishment to escape the town / city to experience calm atmosphere and the nature.</p>	<p>HECTOR, Jackie Grondeienaar: Talene Landbouhoeve No1 & Eienaar: Rafters Bos- en Sportskroeg / Landowner: Talene Agricultural Holdings No 1 & Owner: Rafters Busch & Sports Bar</p>	<p>Die visuele impak is beoordeel in die Visuele Impak Evaluering wat ingesluit moet word in die Konsep Omgewingsimpakevalueringverslag .Verder is die versagtende maatreeël wat voorgestel word dat bome om die perimeter van die ontwikkeling aangebring word wat die panele sal verbloem.</p> <p>Stephan Jacobs, Environmental Consultant, SiVEST</p> <p>Translation: The visual impact has been assessed in the Visual Impact Assessment to be included in the Draft Environmental Impact Assessment Report (DEIAR). In addition, one of the mitigation measures suggested is that trees be planted along the perimeter of the development, which will lessen the view of the panels.</p>
4. Sosio- en Sosio-Ekonomiese Aanverwante Kommentaar/Kwessies – Social and Socio-economic Related Comments/Concerns		
<p>Misnoeë is uitgespreek dat slegs een grondeienaar finansiële voordeel sal kry uit die voorgestelde ontwikkeling. Dit was genoem dat omliggende grondeienaars wat met die impakte gaan sit moet ook vergoeding ontvang.</p> <p>Translation: Displeasure was expressed that only one landowner will gain financial advantage from the proposed development. It was mentioned that the</p>	<p>YARIHAWA, Fazel, Grondeienaar: Talene Landbouhoeve No 4 / Landowner: Talene Agricultural Holdings No 4</p>	<p>Dit is standaard praktyk dat die eienaar op wie se grond 'n ontwikkeling voorgestel word, vergoeding ontvang en enige impakte op omliggende eiendomme, indien enige, moet versag word en dié word gedoen deur die versagtens maatreeëls soos deur die betrokke omgewingspasielyst voorgestel in die konsep OBP.</p> <p>Indien die voorgestelde kraglyn oor die aangrensende landbouhoeves gaan, sal die betrokke eienaar(s) vergoeding ontvang vir die geregistreerde serwituu.</p>

<p>adjacent landowners who will be on the receiving end of negative impacts are not receiving any compensation.</p>		<p>Irene Bezuidenhout, Omgewingsbestuurder, BioTherm Energy</p> <p>Translation: It is standard practice that the owner on whose property a development is being proposed be compensated. Should there be any negative impacts on surrounding properties, these impacts must be mitigated as recommended by the relevant environmental specialist in the draft EMPr. If the proposed power line traverses the adjacent agricultural holdings, the relevant landowners(s) will receive compensation for the registered servitude.</p>
---	--	---

5. Projek Aanverwante Kommentaar/Kwessies – Project Related Comments/Concerns

<p>Dit was verneem watter proses is gevolg vir die besluitneming dat die voorgestelde ontwikkeling op Mnr Hartzenberg se plaas Houthaalbomen ontwikkel word.</p> <p>Translation: It was enquired as to what was the process followed to decide that the proposed development be sited on Mr Hartzenberg's farm Houthaalboomen.</p>	<p>YARIHAWA, Fazel, Grondeienaar: Talene Landbouhoeve No 4 / Landowner: Talene Agricultural Holdings No 4</p>	<p>BioTherm se proses behels kortliks die volgende:</p> <ul style="list-style-type: none"> • eerstens vas watter area is mees geskik vir 'n ontwikkeling soos bv sonkrag; • eiendom moet verkieslig naby Eskom elektrisiteitsnetwerk geleë wees bv substasie / kraglyne; • 'n minimum grootte eiendom is nodig om die MW kapasiteit te kan opwek; • daarna word gekyk na beskikbare eiendomme in die area; • eienaar(s) word genader; ens <p>Irene Bezuidenhout, Omgewingsbestuurder, BioTherm Energy</p> <p>Translation: BioTherm's process, in short, consist of the following:</p> <ul style="list-style-type: none"> • firstly, a suitable site needs to be determined for a development such as solar power; • the Property must be situated near Eskom's utility grid i.e. a substation / power lines; • a minimum size property is required to generate the required MW capacity;
---	---	--

		<ul style="list-style-type: none"> • then one looks for available properties in the area; • owner(s) will then be approached; etc.
6. Kraglyn Korridor Aanverwante Kommentaar/Kwessies – Power Line Corridor Related Comments/Concerns		
<p>Teenkanting teen die voorgestelde deurgang deur Talene Landbouhoewes word ten sterkste uitgespreek. Die landbouhoewes is klein porsies en dit sal die eiendomme frakmenteer wat enige toekomstige ontwikkeling kan belemmer.</p> <p>Dit word voorgestel dat die kraglyne op die voorgestelde solar terrein opgerig word.</p> <p>Translation: Objection was raised regarding the proposed power line corridor through Talene Agricultural Holdings and strongly objected to. The agricultural holdings' properties are very small and it would hamper any future development on the property.</p> <p>It is being proposed that the power lines be constructed on the property where the solar development is being proposed.</p>	<p>YARIHAWA, Fazel, Grondeienaar: Talene Landbouhoewe No 4 / Landowner: Talene Agricultural Holdings No 4</p>	<p>Die teenkanting word erken.</p> <p>Lynsey Rimbault, Omgewingskonsultant, SiVEST</p> <p>Translation: Objection was acknowledged.</p>
<p>Dit was voorgestel dat SiVEST die vernouing van die korridor deur Talene Landbouhoewes om enige moontlike magtiging van die korridor deur die DOE te verhoed.</p> <p>Translation: It was suggested that SiVEST consider narrowing the power line corridor traversing the Talene Agricultural Holdings to avoid the possible approval by the DEA for the corridor.</p>	<p>VENTER, Nicolene PPP, Zitholele Consulting</p>	<p>Hierdie kan 'n lewensvatbare opsie wees en SiVEST sal die aangeleentheid met die Aansoeker bespreek. Die uitkoms van die gesprek sal in die konsepnotule vervat word.</p> <p>Lynsey Rimbault, Omgewingskonsultant, SiVEST</p> <p>This could be a viable option and SiVEST will discuss this with the applicant. The outcome of the discussion will be included in the draft Minutes of the meeting.</p> <p>Post-meeting note: The corridor has been narrowed so that it no longer transects the Talene smallholdings. A map showing the amended corridor has been appended to the minutes.</p>
7. Kommunikasie Aanverwante Kommentaar/Kwessies - Communication Related Comments/Concerns		
<p>Dit was verneem hoekom die ander grondeienaars (spesifieke verwysing na Mnr Hartzenberg en ander landbouhoewes eienaars) nie by die vergadering teenwoordig is nie.</p>	<p>YARIHAWA, Fazel, Grondeienaar: Talene Landbouhoewe No 4 /</p>	<p>Al die omliggend grondeienaars is uitgenooi na die fokusgroepvergadering. Die onus en besluit berus by die uitgenooïdes of hulle die vergadering gaan / kan bywoon of nie. Die publieke deelname span kan nie grondeienaars dwing</p>

Die opinie is geopper dat die proses 'n "white wash" proses is aangesien Mnr Hartzenberg teenwoordig moes gewees het en die mening ook uitgespreek dat die OIE proses slegs 'n "tick box" oefening is.

Translation:

It was enquired as to why the other landowners (specific reference was made to Mr. Hartzenberg and other agricultural holding owners) were not present at the meeting.

The opinion was made that the process is a "white wash" process as Mr. Hartzenberg should have been present and the view that the EIA process was only a "tick box" exercise was expressed.

Die projekspan was ingelig dat die fokusgroepvergadering is nie die regte forum om die omliggende grondeienaars se kwessies te opper nie aangesien hulle nie volwaardig verteenwoordig is nie.

Landowner: Talene Agricultural Holdings No 4

om 'n vergadering by te woon nie end it is ook nie die rol en doel van die publieke deelname proses nie. Die vergadering is 'n geleentheid wat daargestel word om meer inligting oor die projek te bekom en om met die projekspan in gesprek te kan tree oor enige aspek van die projek en omgewingsproses.

Dieselfde rede genoem hierbo geld vir die eienaar op wie se eiendom die ontwikkeling voorgestel word.

Publieke deelname is 'n belangrike aspek van enige OIE en belanghebbendes en geaffekteerde partye so wyd as moontlik word van 'n voorgestelde ontwikkeling in kennis gestel. Om verdere inligting rakende 'n voorgestelde ontwikkeling te bekom, berus ook by die publiek en omliggende grondeienaars.

Nicolene Venter, Publieke Deelnamekonsultant, Zitholele Consulting

Translation:

All the surrounding landowners were invited to the focus group meeting. The onus and decision to attend or not attend the meeting rests with the invitees. The public participation team cannot force landowners to attend the meeting and it is also not the role and responsibility of the public participation process. The meeting is an event that is presented to obtain more information about the project and to interact with the project team regarding any aspect of the project and environmental process

The same reason mentioned above applies to the owner on whose property the development is proposed.

Public participation is an important aspect of any EIA and to inform interested and affected parties as widely as possible regarding a proposed development. To obtain further information regarding a proposed development is also the responsibility of the public and surrounding landowners.

Die versoek is aan die verteenwoordigtes gerig oor hoe hulle hul insette rakende die voorgestelde projek will lewer.

<p>Translation: The project team was informed that the focus group meeting is not the correct forum to raise their (the surrounding land owners) issues as they are not represented fully.</p>		<p>Die voorstel van die publieke deelname konsultant was dat die grondeienaars bymekaar kom en 'n gesamentlike dokument / brief aan die projekspan rig met hulle kwellinge / kwessies rakende die projek.</p> <p>Die projekspan versoek dat hierdie skrywe so spoedig moontlik ingedien moet word.</p> <p>Nicolene Venter, Publieke Deelnamekonsultant, Zitholele Consulting</p> <p>Translation: The request was made to the attendees as to how they would prefer to submit their inputs regarding the proposed project. The public participation consultant suggested that the landowners meet and submit a combined document / letter to the project team which document their concerns / issues regarding the project.</p> <p>The project team requested that this document be submitted to them as soon as possible.</p>
<p>Die voorstel dat 'n skriftelike dokument wat die kwellinge / kwessies van die omliggende grondeienaars bevat, word deur die teenwoordiges aanvaar.</p> <p>Translation: The recommendation that a written submission be made which reflects the concerns / issues of the surrounding landowners was accepted by those present.</p>	<p>YARIHAWA, Fazel, Grondeienaar: Talene Landbouhoewe No 4 / Landowner: Talene Agricultural Holdings No 1 en / and HECTOR, Jackie Grondeienaar: Talene Landbouhoewe No1 & Eienaar: Rafters Bos- en Sportskroeg / Landowner: Talene Agricultural Holdings No 1 & Owner: Rafters Busch & Sports Bar</p>	<p>Die teenwoordiges word voorlopig bedank vir hulle waardevolle insette.</p> <p>HECTOR, Jackie</p> <p>Nicolene Venter, Publieke Deelnamekonsultant, Zitholele Consulting</p> <p>Translation: The attendees were thanked, in advance, for their valuable inputs.</p>

Annexure D









AMENDED TLISITSENG 1 POWER LINE CORRIDOR MAP

PROPOSED CONSTRUCTION OF A 132kV POWER LINE TO SERVE PROPOSED PHOTOVOLTAIC (PV) ENERGY FACILITIES

TLITSSENSOLAR 1
NEAR LICHTENBURG
NORTH WEST PROVINCE

AMENDED CORRIDOR

Legend

-  Main Roads
-  Railway Line
-  Existing High Voltage Power Lines (132kV)
-  Adjoining Farm Boundaries
-  Proposed Tlitsensol PV Application Site
-  Existing Substation
-  Amended Power Line Corridor (Project 1)
-  Proposed Substation Alternatives

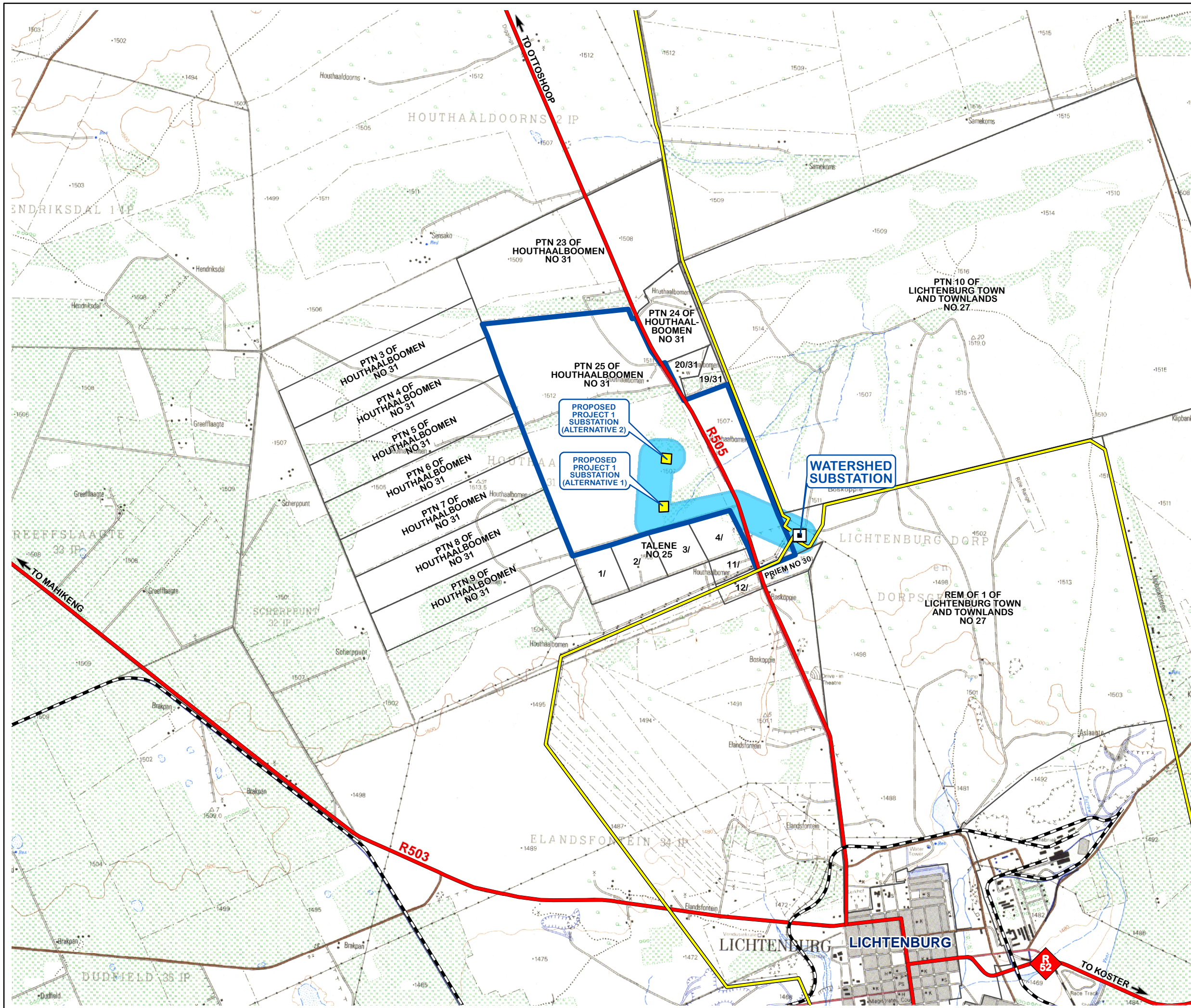

SOURCE:
ESKOM, 2012
BIOTHERM ENERGY, 2015
NGI, 2015

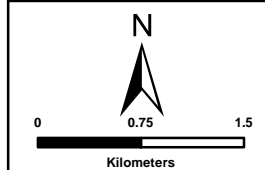

SIVEST

ENVIRONMENTAL DIVISION
51 WESSELS ROAD
RIVONIA, 2128
JOHANNESBURG
SOUTH AFRICA

Phone: +27 11 798 0600
Fax: +27 11 803 7272
e-mail: info@sivest.co.za

Project No 13303	Prepared By KLS	Date 28/04/2016
---------------------	--------------------	--------------------

Map Ref No 13303TPL/BA1_08	Revision 0	Date
-------------------------------	---------------	------

"COPYRIGHT IS VESTED IN SIVEST IN TERMS OF THE COPYRIGHT ACT (ACT 98 OF 1978) AND NO USE OR REPRODUCTION OR DUPLICATION THEREOF MAY OCCUR WITHOUT THE WRITTEN CONSENT OF THE AUTHOR"

THIS MAP HAS BEEN PREPARED UNDER THE CONTROLS ESTABLISHED BY THE SIVEST QUALITY MANAGEMENT SYSTEM WHICH HAS BEEN CERTIFIED ISO 9001:2008 COMPLIANT



SiVEST Environmental (Pty) Ltd

Contact: Lynsey Rimbault

Address: PO Box 2921
51 Wessels Road
Rivonia 2128

Tel: 011 798 0600

Fax: 011 803 7272

E-mail: lynseyr@sivest.co.za

**Environmental Impact Assessments (EIA)
for the Two Tlisitseng Solar Photovoltaic
(PV) Energy Facilities, and Basic
Assessments for the Associated
Substations and Power Lines, near
Lichtenburg, North West Province**

**Feedback of the
Focus Group Meeting (FGM)**

Authorities

**Held on
Monday 14 March 2016 at 14h00**

**Municipality Library, Civic Centre, Cnr Nelson Mandela
and Transvaal Streets.**

North West Province

FOCUS GROUP MEETING

Venue: Municipality Library, Civic Centre, Cnr Nelson Mandela and Transvaal Streets, Lichtenburg
Date: Monday, 14 March 2016
Time: 14h00 – 15h00

Except for the representatives from SiVEST, Zitholele and BioTherm Energy, no one attended the Focus Group Meeting (FGM). A copy of the Attendance Record is attached as **Annexure A**. All relevant authorities were invited to the workshop in writing (email notification, **Appendix C**).

Due to the lack of attendees nothing was presented at the meeting, however, a copy of the presentation (as prepared) is attached as **Annexure B**.

Annexure A

ATTENDANCE RECORD

TLISITSENG SOLAR PROJECTS: AUTHORITY FOCUS GROUP MEETING ATTENDANCE RECORD		
First Name	Last Name	Company
Irene	Bezuidenhout	BioTherm Energy
Siphelele	Dunga	BioTherm Energy
Thulani	Koom	BioTherm Energy
Daniel	Lowings	BioTherm Energy
Lynsey	Rimbault	SiVEST
Stephan	Jacobs	SiVEST
Nicolene	Venter	Zitholele Consulting

Annexure B

COPY OF PRESENTATION

ENVIRONMENTAL IMPACT ASSESSMENTS FOR THE TWO TLISITSENG SOLAR PHOTOVOLTAIC ENERGY FACILITIES, AND BASIC ASSESSMENTS FOR THE ASSOCIATED SUBSTATIONS AND POWER LINES, NEAR LICHTENBURG, NORTH WEST PROVINCE

DEA Ref. No.: TLISITSENG PV SOLAR 1: 14/12/16/3/3/2/889
 TLISITSENG PV SOLAR 2: 14/12/16/3/3/2/890
 TLISITSENG 1 SUBSTATION AND POWER LINE: To be confirmed
 TLISITSENG 2 SUBSTATION AND POWER LINE: To be confirmed

A PROFESSIONAL TEAM DELIVERING CREATIVE PROJECT SOLUTIONS

Consulting Engineers • Project Managers • Environmental Consultants • Town and Regional Planners

FOCUS GROUP MEETING

PRESENTATION DATE: 14 March 2016

1

AGENDA

SIVEST

- Welcome, introduction and apologies
- Purpose and conduct of meeting
- Background to the proposed development
- Environmental process followed and findings
- Discussion session
- Closure

2

PURPOSE OF MEETING

SIVEST

- To provide an overview of the proposed project
- To provide feedback on the findings as documented in EIA phase and BA specialist reports
- Provide an opportunity to raise comments and/or concerns regarding the proposed project
- To record comments, issues and concerns raised

3

PROJECT OVERVIEW

SIVEST

4

PROJECT OVERVIEW

SIVEST

- **What does the proposed development entail?**
 - Construction of Tlisitseng 1 and Tlisitseng 2 Solar Photovoltaic (PV) energy facilities, each with a maximum generation capacity of 75MW.
 - Including associated infrastructure for each facility
 - New onsite substation
 - Access road upgrades
 - Construction laydown area
 - Admin and warehouse building
 - Tlisitseng 1 and Tlisitseng 2 substations and 132kV power lines to connect the proposed substation to the existing Watershed MTS
- **Why is the project being proposed?**
 - To generate electricity to feed into the national grid
 - Promote use of renewable energy
 - To help meet future energy consumption requirements

5

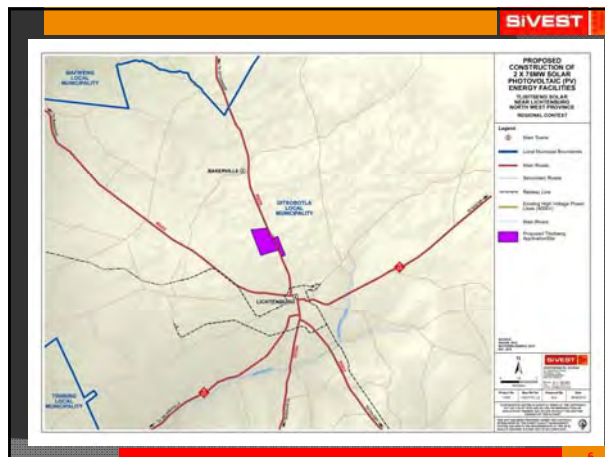

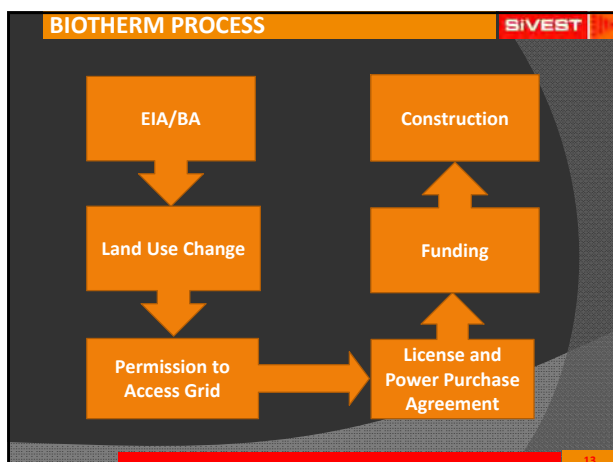

6



ENVIRONMENTAL FINDINGS



- ### ENVIRONMENTAL FINDINGS
- EIA phase / BA underway
 - Rating of significance of impacts
 - Compliance with Equator Principles
 - Compliance with all National legislation
 - Comparative assessment of on site alternatives
 - Environmental Management Programme
 - Environmental aspects being assessed
 - Biodiversity (flora and fauna)
 - Avifauna
 - Surface Water
 - Soils and Agricultural Potential
 - Visual
 - Heritage and Palaeontology
 - Socio-economic

BIODIVERSITY

	Tlitseng PV 1	Tlitseng PV 2	Tlitseng 1 Substation and Power Line	Tlitseng 2 Substation and Power Line
General Findings	<ul style="list-style-type: none"> • Vegetation (Carletonville Dolomite Grassland) is classified as Vulnerable, but has a wide distribution and extent, therefore considered to have moderately high conservation value • However, Provincial Biodiversity Conservation Assessment identifies Critical Biodiversity Areas and Ecological Support Areas → buffer areas for pans, and dolomite aquifer recharge zone. • Potential presence of: <ul style="list-style-type: none"> • 4 plant species of concern, the bulbs, <i>Boophone disticha</i> and <i>Crinum macowanii</i>, the succulent herb, <i>Brachystelma incanum</i>, and the herb, <i>Cleome conrathii</i>. • 1 protected plant species, <i>Harpagophytum procumbens</i>. • 3 protected tree species, <i>Acacia erioloba</i>, <i>Commersonia imberbe</i> and <i>Boscia albitrunca</i>. The tree <i>Acacia erioloba</i> occurs in large numbers on site. • Brown Hyaena, Honey badger, Southern African Hedgehog, White-tailed Rat, Giant Bullfrog. 			
Mitigation	Undertaking a botanical walk-through survey, search-and-rescue for any appropriate species, obtaining permits for any protected species.			
	 <p><i>Boophone disticha</i></p>		 <p><i>Acacia erioloba</i></p>	



Some issues related to the ecology of the site could result in potentially significant impacts but the seriousness of these impacts is not considered to be high.

AVIFAUNA



	Tlitseng PV 1	Tlitseng PV 2	Tlitseng 1 Substation and Power Line	Tlitseng 2 Substation and Power Line
General Findings	<ul style="list-style-type: none"> • The projects are located in the Grassland avifaunal endemic region which has the fourth highest number of endemic bird species in southern Africa. • An estimated 284 species could potentially occur at the core study area and immediate surroundings (including the Lichtenburg Game Breeding Centre and wetland areas south-east of the project). Of these, 21 are South African Red Data species, 12 are southern African endemics and 21 are near-endemics. • The application site should therefore be regarded as moderately sensitive. • Highly sensitive areas are: surface water (boreholes) and high voltage lines which are used for roosting by Cape and White-backed Vultures. • Beyond the core study area, high voltage lines, a vulture restaurant, and wetlands and dams are potential high sensitive areas 			
Mitigation	No fatal flaws identified thus far, and the proposed development could therefore be authorised, provided all proposed mitigation measures are implemented.			
	 <p>Northern Black Korhaan</p>		 <p>White-backed Vulture</p>	



Monitoring is ongoing and in depth statistical analyses will be performed on the full dataset after the monitoring has been completed.

SURFACE WATER

	Tlitseng PV 1	Tlitseng PV 2	Tlitseng 1 Substation and Power Line	Tlitseng 2 Substation and Power Line
General Findings	<ul style="list-style-type: none"> • Vaal Primary Catchment (C31A quaternary catchment); Lower Vaal Water Management Area • Depression wetland on greater application site has small chance of being indirectly affected by the proposed development. 			
	No pan wetlands would be directly affected.	One depression wetland could be directly affected.	No pan wetlands would be directly affected.	One depression wetland could be directly affected.
Mitigation	Preventing loss of wetland habitat, increased run-off, erosion and sedimentation			
				

SOILS AND AGRICULTURAL POTENTIAL				
	Tlitsitseng PV 1	Tlitsitseng PV 2	Tlitsitseng 1 Substation and Power Line	Tlitsitseng 2 Substation and Power Line
General Findings	<ul style="list-style-type: none"> Soils in the vicinity of the project were generally shallow to very shallow, however, some areas of deeper red soils, which will have a higher agricultural potential, can also occur. The soils are reddish-brown to brown, and belong to the Mispah, Glenrosa and Hutton soil forms This part of North West is well suited for grazing but here the grazing capacity is relatively low, around 12 ha/large stock unit Despite the dominance of shallow soils in the area, areas of cultivation on the deeper soils can be seen in the vicinity, including various centre pivot fields. 			
	At one point red Hutton soil of approximately 1 000 mm deep was observed.	At several points, the soil was seen to be deep (>750 mm), but these points were generally isolated.	Although there are deeper soils in the vicinity there is no evidence of cultivation along the rest of the corridor.	Although there are deeper soils that were observed in places, there is no evidence of cultivation along the rest of the corridor
Mitigation	Due to low agricultural potential, little or no mitigation measures are required. The footprint of the development should be kept to a minimum, so that at least the effect on grazing land for livestock is reduced.			

VISUAL				
	Tlitsitseng PV 1	Tlitsitseng PV 2	Tlitsitseng 1 Substation and Power Line	Tlitsitseng 2 Substation and Power Line
General Findings	<ul style="list-style-type: none"> Study area has a natural visual character, with a rural or pastoral component. Not generally valued for its tourism significance and is rated as having a low visual sensitivity. The R505 main road is considered to be a visually sensitive road and the relatively high volumes of motorists would be visually exposed to the project. Several farmsteads are regarded as potentially sensitive visual receptors. 			
	One sensitive receptor is present in the study area, namely the Lichtenburg Game Breeding Centre. This visually sensitive receptor was used as a tourism facility.		Two sensitive receptors are present in the study area, namely the Game Breeding Centre and the Lichtenburg Vakansie Oord which is used as a tourism facility.	
Mitigation	Minimise vegetation clearing and rehabilitate cleared areas as soon as possible. Ensure that dust suppression techniques are implemented. Light fittings for security at night should reflect the light toward the ground and prevent light spill.			
	 <p style="text-align: center;">Low visual impact during construction, Medium visual impact during operation</p> 			

HERITAGE AND PALAEOLOGY				
	Tlitsitseng PV 1	Tlitsitseng PV 2	Tlitsitseng 1 Substation and Power Line	Tlitsitseng 2 Substation and Power Line
General Findings	<ul style="list-style-type: none"> Two Stone Age sites were found, both of low significance Five historical structures were located, the age of which has not been determined, most are likely older than 60 years. An informal cemetery of approx. 60 graves is located at the eastern side of the application site. Micro-stromatolites and possible sites with cave breccia have been identified. 		<ul style="list-style-type: none"> Two historical structures were located, and are not significant. Several arbitrary finds of dolomite and chert with significantly well-defined stromatolites as well as a few potential sites with either associated sinkholes or cave breccias were recorded. 	
Mitigation	Sensitive sites will require mitigation work, including destruction permits in terms of section 34 of the NHRA. A 50m buffer must be provided around the cemetery, alternatively a grave relocation process will need to occur			
	 <p style="text-align: center;">The overall impact on heritage resources is acceptable, mitigation measures address any impacts on heritage.</p> 			

SOCIO-ECONOMIC				
	Tlitsitseng PV 1	Tlitsitseng PV 2	Tlitsitseng 1 Substation and Power Line	Tlitsitseng 2 Substation and Power Line
General Findings	<ul style="list-style-type: none"> Positive and negative impacts → including skills development and employment creation, but also change in sense of place among others. The significance of the possible positive impacts of the proposed development outweighs the negative impacts. The project would generate positive socio-economic returns for the local economy and its community and should be considered for implementation The directly impacted land owner has indicated that alternative land can be acquired, to allow him to continue the current levels of agriculture production. 			
			Some land owners have objected due to the possible visual impact.	
Mitigation	<ul style="list-style-type: none"> Mitigation measures should be implemented to maximise the benefit to the local community. Care should be taken not to affect the supply of water extracted from boreholes on nearby farms. The issues of safety and livestock theft should be addressed. 			
			It is recommended that the corridor be shifted to remain within Portion 25 of Farm Houthaalboom 31.	

LAYOUT ALTERNATIVES

- Layout alternatives will be presented in the DEIARs and DBARs.
- Design to incorporate specialist findings and stakeholder input.

PUBLIC PARTICIPATION

SIVEST

25

PUBLIC PARTICIPATION – SCOPING PHASE

SIVEST

ONGOING I&AP IDENTIFICATION & CONSULTATION

- Site Notices and Stakeholder Consultation
December 2015
- BID Comment Period
December 2015 – January 2016
- EIA Process Advertisement
January 2016
- DSR Availability
DSR Review Period: 11 January 2016 – 09 February 2016
- FSR Availability and Submission to DEA
February 2016

26

PUBLIC PARTICIPATION – EIA PHASE AND BA

SIVEST

ONGOING I&AP IDENTIFICATION & CONSULTATION

- Environmental Meetings
14 March 2016
- DEA Acceptance of FSR and EIA Plan of Study
April 2016
- EIA Newsletter
April 2016
- DEIAr and DBAR Availability
April 2016
- FEIAr and FBAR Availability and Submission to DEA
June 2016
- Notify I&APs of EA and Appeal Process
September/October 2016

27

DISCUSSION

SIVEST

28

CONTACT DETAILS

SIVEST

SIVEST Environmental Division
PO Box 2921
Rivonia
2128

Lynsey Rimbault/ Nicolene Venter
Phone: (011) 798 0600
Fax: (011) 803 7272
E-mail: lynseyr@sivest.co.za / nicolenev@zitholele.co.za
Website: www.sivest.co.za

29

WAY FORWARD

SIVEST

- Draft Minutes of Meeting
Distribute: 2 weeks after meeting
- DEIAr and DBAR Availability
Public Review: Envisaged April – May 2016 (30 Days) | Submit to DEA: Envisaged April 2016
- Submission of FEIAr and FBAR to DEA
Envisaged June 2016
- DEA Decision
Envisaged September/October 2016

30

Annexure C

PROOF OF NOTIFICATION

Hlengiwe Ntuli

From: Hlengiwe Ntuli
Sent: 07 March 2016 06:17 PM
To: Rebecca Thomas; Lynsey Rimbault; 'nicolenev@zitholele.co.za'
Cc: 'Kobus Visser'; 'Simpfiwe Masilela'; 'Johanna Morobane'; 'Simon Gear'; 'Godfrey Samore'; 'Mashudu Marubini'; 'Anneliza Collett'; 'Thoko Buthelezi'; 'Pheladi Masipa'; 'Lerato April'; 'Seoka Lekota'; 'Mmatlala Rabothata'; 'Pieter Swart'; 'Doris Maumela'; 'Lesego Holele'; 'Pogiso Maitshotlo'; 'J Molefe'; 'KRJ Zandamela'; 'John Geeringh'; 'Lourens Leeuwner'; 'Mpho Phiri'; 'M W Moholatsi'; 'Lehlohonolo March'; 'Nono Dince'; 'Yoliswa Sechoaro'; 'Alfred Mafune'; 'Matshediso Mahlaku'; 'Tebogo Sethosa'; 'Bonolo Mohlakoana'; 'SM Matsheka'; 'Lizell Stroh'; 'Harry Roberts'; 'J Oliver'; 'Shaun Dyers'; 'Johan Koegelenberg'; 'Chris Nthaudi'; 'Annette Van Zyl-Swart'; 'Sam Fiff'; 'Suzanne Erasmus'; 'Morgan Griffiths'
Subject: Tlisitseng PV Focus Group Meeting
Attachments: 13303 Tlisitseng Authority FGM Agenda_Rev 1_7March2016 RT.PDF; 13303 Tlisitseng Authority FGM Registration Form_Rev1_7March2016 RT.PDF

Tracking:	Recipient	Delivery	Read
	Rebecca Thomas	Delivered: 2016/03/07 06:17 PM	Read: 2016/03/08 09:32 AM
	Lynsey Rimbault	Delivered: 2016/03/07 06:17 PM	
	'nicolenev@zitholele.co.za'		
	'Kobus Visser'		
	'Simpfiwe Masilela'		
	'Johanna Morobane'		
	'Simon Gear'		
	'Godfrey Samore'		
	'Mashudu Marubini'		
	'Anneliza Collett'		
	'Thoko Buthelezi'		
	'Pheladi Masipa'		
	'Lerato April'		
	'Seoka Lekota'		
	'Mmatlala Rabothata'		
	'Pieter Swart'		
	'Doris Maumela'		
	'Lesego Holele'		
	'Pogiso Maitshotlo'		
	'J Molefe'		
	'KRJ Zandamela'		
	'John Geeringh'		
	'Lourens Leeuwner'		
	'Mpho Phiri'		
	'M W Moholatsi'		
	'Lehlohonolo March'		
	'Nono Dince'		
	'Yoliswa Sechoaro'		
	'Alfred Mafune'		

Recipient	Delivery	Read
'Matshediso Mahlaku'		
'Tebogo Sethosa'		
'Bonolo Mohlakoana'		
'SM Matsheka'		
'Lizell Stroh'		
'Harry Roberts'		
'J Oliver'		
'Shaun Dyers'		
'Johan Koegelenberg'		
'Chris Nthaudi'		
'Annette Van Zyl-Swart'		
'Sam Fiff'		
'Suzanne Erasmus'		
'Morgan Griffiths'		

***** Please note that this email was sent from a NO REPLY email address. Please do not reply to this address as it is an unmonitored email account. *****

Dear Stakeholder,

ENVIRONMENTAL IMPACT ASSESSMENT (EIA) AND ENVIRONMENTAL MANAGEMENT PROGRAMME (EMPr) FOR THE TWO TLISITSENG SOLAR PHOTOVOLTAIC (PV) ENERGY FACILITIES, AND BASIC ASSESSMENTS (BA) FOR THE ASSOCIATED SUBSTATIONS AND POWER LINES, NEAR LICHTENBURG, NORTH WEST PROVINCE

DEA Ref. TLISITSENG PV SOLAR 1: 14/12/16/3/3/2/889
 TLISITSENG PV SOLAR 2: 14/12/16/3/3/2/890 TLISITSENG 1 SUBSTATION AND POWER LINE: To be confirmed
 TLISITSENG 2 SUBSTATION AND POWER LINE: To be confirmed

• INVITATION TO FOCUS GROUP MEETING

This letter serves to cordially invite you to attend a Focus Group Meeting (FGM) that will be held on:

DATE: Monday, 14 March 2016

TIME: 14h00

VENUE: Auditorium of the Ditsobotla Local Municipality Library, Civic Centre, Cnr Nelson Mandela and Transvaal Streets, Lichtenburg

This FGM is part of the Environmental Impact Assessment (EIA) processes being undertaken by SiVEST for the above mentioned projects.

As stakeholder we would value your attendance at the FGM. The purpose of this FGM is to:

- ☐ provide feedback on the impact phase environmental findings;
- ☐ provide the opportunity to raise any questions for clarifications regarding the environmental findings;
- ☐ provide the opportunity to raise any comments and/or concerns regarding this proposed project; and
- ☐ record your comments and/or concerns raised at the FGM.

To ensure that sufficient seating is provided at the venue, we kindly request that you complete the attached Registration Form and return it to the Public Participation team on or before Thursday, 10 March 2016.

Please also note that a Public Meeting is being held on the evening of Monday, 14 March 2016 at Lichtenburg Town Hall / Soepe Hall on Nelson Mandela Drive, Lichtenburg at 18h00.

Please feel free to pass this invitation to any other relevant officials from your Department as you deem necessary. We are looking forward to your attendance and meaningful contributions.

Kind Regards,

REBECCA THOMAS (B.Sc Env. Sc.; PDM Business Management) Senior Environmental Scientist SiVEST Environmental Division

SiVEST is a Level 3 BBBEE Contributor

direct +27 11 798 0634 tel +27 11 798 0600 fax +27 11 803 7272 cell +27 82 302 9010
email rebeccat@sivest.co.za website www.sivest.co.za

Consulting Engineers - Project Managers - Environmental Consultants - Town and Regional Planners Durban - Johannesburg - Pietermaritzburg - Richards Bay - Ladysmith - Cape Town - Harare (Zimbabwe)

SiVEST is a Level 3 BBBEE Contributor

Direct +27 11 798 0691 Tel +27 11 798 0600 fax +27 11 803 7272 cell +27 72 779 4899
email shaunt@sivest.co.za website www.sivest.co.za

Consulting Engineers - Project Managers - Environmental Consultants - Town and Regional Planners Durban - Johannesburg - Pietermaritzburg - Richards Bay - Ladysmith - Cape Town - Harare (Zimbabwe)

Your reference

Our reference 13303

Date 7 March 2016

Dear Stakeholder,

ENVIRONMENTAL IMPACT ASSESSMENT (EIA) AND ENVIRONMENTAL MANAGEMENT PROGRAMME (EMPr) FOR THE TWO TLISITSENG SOLAR PHOTOVOLTAIC (PV) ENERGY FACILITIES, AND BASIC ASSESSMENTS (BA) FOR THE ASSOCIATED SUBSTATIONS AND POWER LINES, NEAR LICHTENBURG, NORTH WEST PROVINCE

DEA Ref. TLISITSENG PV SOLAR 1: 14/12/16/3/3/2/889
TLISITSENG PV SOLAR 2: 14/12/16/3/3/2/890
TLISITSENG 1 SUBSTATION AND POWER LINE: To be confirmed
TLISITSENG 2 SUBSTATION AND POWER LINE: To be confirmed

• **INVITATION TO FOCUS GROUP MEETING**

This letter serves to cordially invite you to attend a Focus Group Meeting (FGM) that will be held on:

DATE: Monday, 14 March 2016

TIME: 14h00

VENUE: Auditorium of the Ditsobotla Local Municipality Library, Civic Centre, Cnr Nelson Mandela and Transvaal Streets, Lichtenburg

This FGM is part of the Environmental Impact Assessment (EIA) processes being undertaken by SiVEST for the above mentioned projects.

As stakeholder we would value your attendance at the FGM. The purpose of this FGM is to:

- provide feedback on the impact phase environmental findings;
- provide the opportunity to raise any questions for clarifications regarding the environmental findings;
- provide the opportunity to raise any comments and/or concerns regarding this proposed project; and
- record your comments and/or concerns raised at the FGM.

To ensure that sufficient seating is provided at the venue, we kindly request that you complete the attached Registration Form and return it to the Public Participation team on or before Thursday, 10 March 2016.

Please also note that a **Public Meeting** is being held on the evening of **Monday, 14 March 2016** at Lichtenburg Town Hall / Soepe Hall on Nelson Mandela Drive, Lichtenburg at 18h00.

Please feel free to pass this invitation to any other relevant officials from your Department as you deem necessary. We are looking forward to your attendance and meaningful contributions.

Yours sincerely,



Rebecca Thomas
Environmental Practitioner
SiVEST Environmental Division

Documents attached: Draft Agenda
Registration Form



BioTherm Energy (Pty) Ltd
Building 1, Ground Floor
Leslie Ave East
The Design Quarter District, Four ways
Gauteng, South Africa
P O Box 69408, Bryans ton, 2021
Tel: +27 11 367 4600
Fax: +27 11 367 4601
www.biothermenergy.com
Registration Number: 2003/020443/07
VAT Registration Number: 4620220261

MEETING MINUTES

Purpose: Tlisitseng 2x75MW Solar PV Development
Date: 11 October 2016
Time: 10:15-11:00
Venue: C/o Annie Botha & Union Street, Riveria

Attendees:

Siphelele Dunga- BioTherm Energy
Irene Bezuidenhout- BioTherm Energy
Tonderai Munthumbira- BioTherm Energy
Mabule Ramodike- Department of Agriculture, Forestry and Fisheries

MATTERS ARISING

1. WELCOME AND INTRODUCTIONS

- 1.1 Mabule Ramodike ("Mabule") welcomed BioTherm Energy to the DAFF Offices.
- 1.2 A round of introductions was done including:
 - BioTherm Energy Proprietary Limited ("BioTherm")- Siphelele Dunga, Irene Bezuidenhout and Tonderai Munthumbira
 - Department of Agriculture, Forestry and Fisheries ("DAFF")- Mabule Ramodike

2. PROJECT CONCERNS

- 2.1 Mabule noted that the proposed Tlisitseng development lies within an area of high agricultural potential with a land capability of III.

3. DISCUSSION

- 3.1 Mabule noted that in terms of categorising land, the Department looks at the potential of the land for agricultural production. The character of the surrounding land is also looked at.
- 3.2 Mabule enquired whether BioTherm had looked at other development areas in the area which had less agricultural potential. BioTherm advised that they

have but the chosen area is the best for development as it is closer to the Eskom point of connection and has not been signed up by other parties. The site also has the best solar irradiance in the area and will be the best for development.

3.3 Mabule also noted that the Department does soil sampling in order to look for potential for agricultural production.

3.4 It was further noted that in future, BioTherm should submit the details of the property they intend to develop to the Department before doing any development work on the land.

- With their submission, BioTherm should attach title deeds or/and a power of attorney to the Department.

3.5 The Department is revising their criteria for agricultural land use and it will be divided into fifteen (15) land capability Classes from the current eight (8) zones.

- The current zones are ranked from one (1) having the most agricultural potential to 8 having the least agricultural potential.

3.6 The BioTherm development falls within the a land capability zone of three.

4. WAY FORWARD

4.1 The Department noted that it would prefer BioTherm utilising an area with less agricultural potential.

4.2 BioTherm proposed to look at other layout alternatives within the proposed development area.

4.3 BioTherm would also decrease the size of the BioTherm development from 2x75MW to 1x75MW in order to have less impact on the agricultural land.

4.4 BioTherm proposed to come up with a rehabilitation plan for the development which will minimise the impacts to agricultural land.

Andrea Gibb

From: Godfrey Samore <gsamore@nwpg.gov.za>
Sent: Wednesday, December 02, 2015 3:54 PM
To: Andrea Gibb; Lynsey Rimbault
Cc: Info
Subject: Job Creation

Good day

Title : Mr.	First Names: Godfrey Gaogakwe
Initials : GG	Surname: Samore
Organisation : Community Police Forum / LIBRARIAN	EMAIL: gsamore@nwpg.gov.za OR
ggsamore@gmail.com	
Postal Address: 372 Tilo Street Boikhutso Location Lichtenburg	Postal Code: 2740
Tel : 083 509 2695 OR 018 633 3904	Fax: 086 563 7433

I just want to know if this will be able to create a **permanent jobs** for the surrounding community if so then it is fine. Last other thing please let this BioTherm Energy not **cause harm** to our community please.

I will be waiting for you to call community meeting for Public Participation.

Thank you in advance for your attention.

Regards

GG Samore

TAKE ACTION. INSPIRE CHANGE.
MAKE EVERY DAY A MANDELA DAY.



Disclaimer

"This e-mail and any files transmitted with it may contain information which is confidential, private or privilege in nature and it is for the sole use of the recipient to whom it is addressed. If you are not the intended recipient, you must immediately notify the sender via electronic mail and further refrain from reading, disseminating, distributing, copying or using this message or any of its transmitted files. Any views of this message and its transmitted files are those of the sender unless the sender specifically states such views to be those of the North-West Provincial Government. Though this message and its transmitted files have been swept for the presence of computer viruses, the North-West Provincial Government accepts no liability whatsoever for any loss, damage or expenses resulting directly or indirectly from the use or access of this message or any of its transmitted files."

Andrea Gibb

From: John Geeringh <GeerinJH@eskom.co.za>
Sent: Monday, January 11, 2016 2:16 PM
To: Andrea Gibb
Subject: Tlitseng Solar PV Projects
Attachments: Eskom requirements for work in or near Eskom servitudes SOLAR (3).doc;
Renewable Energy Generation Plant Setbacks to Eskom Infrastructure - Signed.pdf

Categories: BioTherm

Please find attached requirements for renewable works at or near Eskom infrastructure. Please send me copies of all documents on CD via registered mail.

Regards

John Geeringh (Pr Sci Nat)
Senior Consultant Environmental Management

Eskom GC: Land Development
Megawatt Park
D1Y39
P O Box 1091
Johannesburg
2000

Tel: 011 516 7233
Fax: 086 661 4064
Cell: 083 632 7663

I'm part of the 49Million initiative...
<http://www.49Million.co.za>

NB: This Email and its contents are subject to the Eskom Holdings SOC Limited EMAIL LEGAL NOTICE which can be viewed at http://www.eskom.co.za/Pages/Email_Legal_Spam_Disclaimer.aspx

	<p style="text-align: center;">SCOT</p>	<p style="text-align: center;">Technology</p>
---	--	--

Title: **Renewable Energy Generation Plant Setbacks to Eskom Infrastructure** Unique Identifier: **240-65559775**

Alternative Reference Number: **N/A**

Area of Applicability: **Power Line Engineering**

Documentation Type: **Guideline**

Revision: **0**

Total Pages: **8**

Next Review Date: **N/A**

Disclosure Classification: **CONTROLLED DISCLOSURE**

Compiled by



J W Chetty
Mechanical Engineer

Date: 20/02/2014

Approved by



V Naidoo
Chief Engineer (Lines)

Date: 24/02/2014

Authorised by

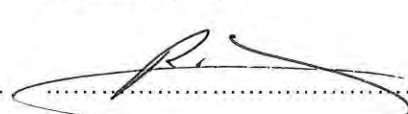

R A Vajeth
Acting Snr Manager (Lines)

Date: 27/2/2014

Supported by SCOT/SC



R Vajeth
SCOT/SC/ Chairperson

Date: 27/2/2014

PCM Reference: 240-65132732 **LINE ENGINEERING SERVICES**

SCOT Study Committee Number/Name : **OVERHEAD LINES**

CONTENTS

	Page
EXECUTIVE SUMMARY	3
1. INTRODUCTION.....	4
2. SUPPORTING CLAUSES	4
2.1 SCOPE	4
2.1.1 Purpose.....	4
2.1.2 Applicability	5
2.2 NORMATIVE/INFORMATIVE REFERENCES	5
2.2.1 Normative.....	5
2.2.2 Informative	5
2.3 DEFINITIONS	5
2.3.1 Disclosure Classification.....	6
2.4 ABBREVIATIONS	6
2.5 ROLES AND RESPONSIBILITIES	6
2.6 PROCESS FOR MONITORING	6
2.7 RELATED/SUPPORTING DOCUMENTS	6
3. DOCUMENT CONTENT	6
3.1 INTERNATIONAL SETBACK COMPARISON	6
3.2 ESKOM APPROACH FOR WIND FARMS.....	7
4. AUTHORISATION	8
5. REVISIONS.....	8
6. DEVELOPMENT TEAM	9

FIGURES

Figure 1: Horizontal Axis Wind Turbine	8
--	---

CONTROLLED DISCLOSURE

When downloaded from the EDMS, this document is uncontrolled and the responsibility rests with the user to ensure it is in line with the authorised version on the system.

EXECUTIVE SUMMARY

In recent decades, the use of wind turbines, concentrated solar plants and photovoltaic plants have been on the increase as it serves as an abundant source of energy. This document specifies setbacks for wind turbines and the reasons for these setbacks from infrastructure as well as setbacks for concentrated solar plants and photovoltaic plants. Setbacks for wind turbines employed in other countries were compared and a general setback to be used by Eskom was suggested for use with wind turbines and other renewable energy generation plants.

CONTROLLED DISCLOSURE

When downloaded from the EDMS, this document is uncontrolled and the responsibility rests with the user to ensure it is in line with the authorised version on the system.

1. INTRODUCTION

During the last few decades, a large amount of wind turbines have been installed in wind farms to accommodate for the large demand of energy and depleting fossil fuels. Wind is one of the most abundant sources of renewable energy. Wind turbines harness the energy of this renewable resource for integration in electricity networks. The extraction of wind energy is its primary function and thus the aerodynamics of the wind turbine is important. There are many different types of wind turbines which will all exhibit different wind flow characteristics. The most common wind turbine used commercially is the Horizontal Axis Wind Turbine. Wind flow characteristics of this turbine are important to analyse as it may have an effect on surrounding infrastructure.

Wind turbines also cause large turbulence downwind that may affect existing infrastructure. Debris or parts of the turbine blade, in the case of a failure, may be tossed behind the turbine and may lead to damage of infrastructure in the wake path.

This document outlines the minimum distances that need to be introduced between a wind turbine and Eskom infrastructure to ensure that debris and / or turbulence would not negatively impact on the infrastructure.

Safety distances of wind turbines from other structures as implemented by other countries were also considered and the reasons for their selection were noted.

Concentrated solar plants and photovoltaic plants setbacks away from substations were also to be considered to prevent restricting possible power line access routes to the substation.

2. SUPPORTING CLAUSES

2.1 SCOPE

This document provides guidance on the safe distance that a wind turbine should be located from any Eskom power line or substation. The document specifies setback distances for transmission lines (220 kV to 765 kV), distribution lines (6.6 kV to 132 kV) and all Eskom substations. Setbacks for concentrated solar plants and photovoltaic plants are also specified away from substations.

2.1.1 Purpose

Setbacks for wind turbines and power lines / substations are required for various reasons. These include possible catastrophic failure of the turbine blade that may release fragments and which may be thrown onto nearby power lines that may result in damage with associated unplanned outages. Turbulence behind the turbine may affect helicopter flight during routine Eskom live line maintenance and

CONTROLLED DISCLOSURE

When downloaded from the EDMS, this document is uncontrolled and the responsibility rests with the user to ensure it is in line with the authorised version on the system.

inspections that may lead to safety risk of the aircraft / personnel. Concentrated solar plants and photovoltaic plants setback away from substations were required to prevent substations from being boxed in by these renewable generation plants limiting line route access to the substations.

2.1.2 Applicability

This document is applicable to the siting of all new and existing wind turbines, concentrated solar plants and photovoltaic plants near power lines and substations.

2.2 NORMATIVE/INFORMATIVE REFERENCES

2.2.1 Normative

1. <http://www.envir.ee/orb.aw/class=file/action=preview/id=1170403/Hiiumaa+turbulence+impact+EMD.pdf>.
2. <http://www.energy.ca.gov/2005publications/CEC-500-2005-184/CEC-500-2005-184.PDF>
3. <http://www.adamscountywind.com/Revised%20Site/Windmills/Adams%20County%20Ordinance/Adams%20County%20Wind%20Ord.htm>
4. http://www.dsireusa.org/incentives/incentive.cfm?Incentive_Code=PA11R&RE=1&EE=1
5. <http://www.wind-watch.org/documents/european-setbacks-minimum-distance-between-wind-turbines-and-habitations/>
6. <http://www.publications.parliament.uk/pa/ld201011/ldbills/017/11017.1-i.html>
7. http://www.caw.ca/assets/pdf/Turbine_Safety_Report.pdf
8. Rogers J, Slegers N, Costello M. (2011) A method for defining wind turbine setback standards. Wind energy 10.1002/we.468

2.2.2 Informative

None

2.3 DEFINITIONS

Definition	Description
Setback	The minimum distance between a wind turbine and boundary line/dwelling/road/infrastructure/servitude etc.
Flicker	Effect caused when rotating wind turbine blades periodically cast shadows
Tip Height	The total height of the wind turbine ie. Hub height plus half rotor diameter (see Figure1)

CONTROLLED DISCLOSURE

When downloaded from the EDMS, this document is uncontrolled and the responsibility rests with the user to ensure it is in line with the authorised version on the system.

2.3.1 Disclosure Classification

Controlled disclosure: controlled disclosure to external parties (either enforced by law, or discretionary).

2.4 ABBREVIATIONS

Abbreviation	Description
None	

2.5 ROLES AND RESPONSIBILITIES

All personnel involved in the positioning wind turbines, concentrated solar plants and photovoltaic plants near power lines/substations must follow the setbacks outlined in this guideline.

2.6 PROCESS FOR MONITORING

Approval by Eskom in writing.

2.7 RELATED/SUPPORTING DOCUMENTS

None

3. DOCUMENT CONTENT

3.1 INTERNATIONAL SETBACK COMPARISON

Wind Turbine setbacks employed by various countries were considered. It was found that setbacks were determined for various reasons that include noise, flicker, turbine blade failure and wind effects. The distances (setbacks) varied based on these factors and were influenced by the type of infrastructure

Wind turbine setbacks varied for roads, power lines, dwellings, buildings and property and it was noted that the largest setbacks were employed for reasons of noise and flicker related issues [1-7]. Very few countries specified setbacks for power lines.

The literature survey [1-7], yielded information about studies and experiments were conducted to determine the distance that a broken fragment from a wind turbine might be thrown. Even though of low probability of hitting a power line [5.0×10^{-5}]^[8], the distances recorded were significant [750m]^[8]

Setbacks were thus introduced to prevent any damage to Eskom infrastructure.

CONTROLLED DISCLOSURE

When downloaded from the EDMS, this document is uncontrolled and the responsibility rests with the user to ensure it is in line with the authorised version on the system.

Wind turbines may also cause changes in wind patterns with turbulent effects behind the hub. These factors dictate the wind turbine setbacks specified in this document.

Concentrated solar plants and photovoltaic plants also can limit access into the substation for power lines of all voltages. A setback distance must therefore be employed to prevent the substation from being boxed in by these generation plants. These setback distances are specified in this document.

3.2 ESKOM REQUIRED SETBACKS

- Eskom requires a setback distance of 3 times the tip height of the wind turbine from the edge of the closest Eskom servitude (including vacant servitudes) for transmission lines.
- Eskom requires a setback distance of 1 times the tip height of the wind turbine from the edge of the closest Eskom servitude (including vacant servitudes) for distribution Lines.
- Eskom must be informed of any proposed wind turbine, concentrated solar plants and photovoltaic activity within a 5 km radius of a substation. No wind turbine structure shall be built within a 2 km radius of the closest point of the substation. Where concentrated solar plants and photovoltaic structures fall within a 2 km radius of the closest point of a substation, Eskom should be informed in writing during the planning phase of the construction of such plant or structure.
- Applicants must show that Eskom radio telecommunication systems (mainly microwave systems) will not be affected in any way by wind turbines.

CONTROLLED DISCLOSURE

When downloaded from the EDMS, this document is uncontrolled and the responsibility rests with the user to ensure it is in line with the authorised version on the system.

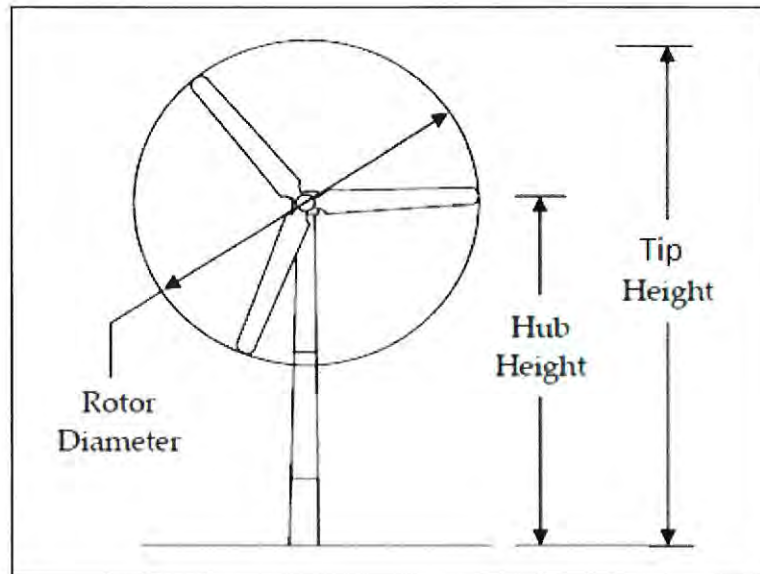

Figure 1: Horizontal Axis Wind Turbine ^[2]

4. AUTHORISATION

This document has been seen and accepted by:

Name & Surname	Designation
V Naidoo	Chief Engineer
Dr P H Pretorius	Electrical Specialist
J Geeringh	Snr Consultant Environ Mngt
B Haridass	Snr Consultant Engineer
R A Vajeth	Acting Snr Manager (Lines)

5. REVISIONS

Date	Rev.	Compiler	Remarks
November 2013	0	J W Chetty	First Publication - No renewable energy generation plant setback specification in existence

CONTROLLED DISCLOSURE

When downloaded from the EDMS, this document is uncontrolled and the responsibility rests with the user to ensure it is in line with the authorised version on the system.

6. DEVELOPMENT TEAM

The following people were involved in the development of this document:

Jonathan W Chetty (Mechanical Engineer)

Vivendhra Naidoo (Chief Engineer)

Dr Pieter H Pretorius (Electrical Specialist)

John Geeringh (Snr Consultant Environ Mngt)

Bharat Haridass (Snr Consultant Engineer)

Riaz A Vajeth (Acting Snr Manager (Lines))

CONTROLLED DISCLOSURE

When downloaded from the EDMS, this document is uncontrolled and the responsibility rests with the user to ensure it is in line with the authorised version on the system.

Eskom requirements for work in or near Eskom servitudes.

1. Eskom's rights and services must be acknowledged and respected at all times.
2. Eskom shall at all times retain unobstructed access to and egress from its servitudes.
3. Eskom's consent does not relieve the developer from obtaining the necessary statutory, land owner or municipal approvals.
4. Any cost incurred by Eskom as a result of non-compliance to any relevant environmental legislation will be charged to the developer.
5. If Eskom has to incur any expenditure in order to comply with statutory clearances or other regulations as a result of the developer's activities or because of the presence of his equipment or installation within the servitude restriction area, the developer shall pay such costs to Eskom on demand.
6. The use of explosives of any type within 500 metres of Eskom's services shall only occur with Eskom's previous written permission. If such permission is granted the developer must give at least fourteen working days prior notice of the commencement of blasting. This allows time for arrangements to be made for supervision and/or precautionary instructions to be issued in terms of the blasting process. It is advisable to make application separately in this regard.
7. Changes in ground level may not infringe statutory ground to conductor clearances or statutory visibility clearances. After any changes in ground level, the surface shall be rehabilitated and stabilised so as to prevent erosion. The measures taken shall be to Eskom's satisfaction.
8. Eskom shall not be liable for the death of or injury to any person or for the loss of or damage to any property whether as a result of the encroachment or of the use of the servitude area by the developer, his/her agent, contractors, employees, successors in title, and assignees. The developer indemnifies Eskom against loss, claims or damages including claims pertaining to consequential damages by third parties and whether as a result of damage to or interruption of or interference with Eskom's services or apparatus or otherwise. Eskom will not be held responsible for damage to the developer's equipment.
9. No mechanical equipment, including mechanical excavators or high lifting machinery, shall be used in the vicinity of Eskom's apparatus and/or services, without prior written permission having been granted by Eskom. If such permission is granted the developer must give at least seven working days' notice prior to the commencement of work. This allows time for arrangements to be made for supervision and/or precautionary instructions to be issued by the relevant Eskom Manager

Note: Where and electrical outage is required, at least fourteen work days are required to arrange it.

10. Eskom's rights and duties in the servitude shall be accepted as having prior right at all times and shall not be obstructed or interfered with.
11. Under no circumstances shall rubble, earth or other material be dumped within the servitude restriction area. The developer shall maintain the area concerned to Eskom's satisfaction. The developer shall be liable to Eskom for the cost of any remedial action which has to be carried out by Eskom.
12. The clearances between Eskom's live electrical equipment and the proposed construction work shall be observed as stipulated by *Regulation 15 of the Electrical Machinery Regulations of the Occupational Health and Safety Act, 1993 (Act 85 of 1993)*.
13. Equipment shall be regarded electrically live and therefore dangerous at all times.
14. In spite of the restrictions stipulated by Regulation 15 of the Electrical Machinery Regulations of the Occupational Health and Safety Act, 1993 (Act 85 of 1993), as an additional safety precaution, Eskom will not approve the erection of houses, or structures occupied or frequented by human beings, under the power lines or within the servitude restriction area.
15. Eskom may stipulate any additional requirements to highlight any possible exposure to Customers or Public to coming into contact or be exposed to any dangers of Eskom plant.
16. It is required of the developer to familiarise himself with all safety hazards related to Electrical plant.
17. Any third party servitudes encroaching on Eskom servitudes shall be registered against Eskom's title deed at the developer's own cost. If such a servitude is brought into being, its existence should be endorsed on the Eskom servitude deed concerned, while the third party's servitude deed must also include the rights of the affected Eskom servitude.

John Geeringh (Pr Sci Nat)

Senior Consultant Environmental Management
Eskom GC: Land Development

Hlengiwe Ntuli

From: Lerato April <Lerato.April@energy.gov.za>
Sent: 10 February 2016 02:47 PM
To: Pheladi Masipa; Niveshen Govender
Cc: Hlengiwe Ntuli
Subject: FW: Two Proposed Tlisitseng Solar Photovoltaic Energy Facilities: DSR Comment Period Ending
Attachments: Two Proposed Tlisitseng Solar Photovoltaic Energy Facilities: DSR Comment Period Starting; Three Proposed Sendawo Solar Photovoltaic Energy Facilities and associated Power Line: DSR Comment Period Ending
Importance: High

Dear Colleagues

Please note the attached document and the email below for your assistance.

Dear Hlengiwe

Please note the contacts details of my colleagues for follow up:

Pheladi Masipa – 012 406 7650

Niveshen Govender – 012 406 7654

Kind Regards
Lerato April

Project Admin
Directorate: Renewable Energy Initiatives
Dept of Energy
192 Cnr visagie & Paulkruger

Private Bag x96
Pretoria
0001
Tel: 012 406 7686
Fax: 086 619 2370

From: Hlengiwe Ntuli [mailto:HlengiweN@sivest.co.za]
Sent: 09 February 2016 02:23 PM
Subject: Two Proposed Tlisitseng Solar Photovoltaic Energy Facilities: DSR Comment Period Ending
Importance: High

***** Please note that this email was sent from a NO REPLY email address. Please do not reply to this address as it is an unmonitored email account. *****

Dear Interested and/or Affected Party

ENVIRONMENTAL IMPACT ASSESSMENTS (EIAs) AND ENVIRONMENTAL MANAGEMENT PROGRAMMES (EMPrs) FOR THE PROPOSED DEVELOPMENT OF THE TWO (2) TLISITSENG 75MW SOLAR PHOTOVOLTAIC (PV) ENERGY FACILITIES, NEAR LICHTENBURG, NORTH WEST PROVINCE (DEA REFERENCE NUMBERS TO BE CONFIRMED)

SIVEST sent the Draft Scoping Report for the proposed Tlisitseng Solar PV near Lichtenburg to your Department on 11 January 2016 for comment (refer to the attached email). Please can you advise if comments will be submitted to us for inclusion in the Final Scoping Report.

We would like to inform you that, the comment period for state departments is ending **today** and you are advised to send your comments to us before **Friday 12 February 2016**.

Kind Regards,

Hlengiwe Ntuli
Projects Secretary
SIVEST Environmental & Civils Divisions



SIVEST is a Level 3 BBBEE Contributor

Direct +27 11 798 0690 **Tel** +27 11 798 0600 **fax** +27 11 803 7272
email HlengiweN@sivest.co.za **website** www.sivest.co.za



Consulting Engineers - Project Managers - Environmental Consultants - Town and Regional Planners
Durban - Johannesburg - Pietermaritzburg - Richards Bay - Ladysmith - Cape Town - Harare (Zimbabwe)

Disclaimer

The information contained in this communication from the sender is confidential. It is intended solely for use by the recipient and others authorized to receive it. If you are not the recipient, you are hereby notified that any disclosure, copying, distribution or taking action in relation of the contents of this information is strictly prohibited and may be unlawful.

This email has been scanned for viruses and malware, and automatically archived by Mimecast SA (Pty) Ltd, an innovator in Software as a Service (SaaS) for business. Mimecast Unified Email Management ??? (UEM) offers email continuity, security, archiving and compliance with all current legislation. To find out more, [contact Mimecast](#).

This e-mail message is subject to the Department of Energy disclaimer, which may be viewed by clicking on the following link: <http://www.energy.gov.za/disclaimer.htm>

Hlengiwe Ntuli

From: Simphiwe Masilela <SimphiweM@atns.co.za>
Sent: 12 February 2016 02:47 PM
To: Hlengiwe Ntuli
Subject: RE: Two Proposed Tlisitseng Solar Photovoltaic Energy Facilities: DSR Comment Period Ending



Good day Hlengiwe,

RE: Two Proposed Tlisitseng Solar Photovoltaic Energy Facilities: DSR Comment Period Ending

Please note that ATNS is aware of the above mentioned.

The area in which the Solar PV will be situated does not affect any of the Annex 14 surfaces or Flight Procedures, however we request that you please update us should there be any new developments that may affect our interests.
Please note that there is a fee attached to the Annex 14 assessment, however we will waive this process as it does not affect any Procedures or Annex14 Surfaces.

We will duly conduct the general assessment as required when the project is ready for construction.

In order for us to carry out a successful assessment we require the following information:

1. LOCATION (Co-ordinates WGS84 system)
2. SITE/GROUND ELEVATION (AMSL)
3. HEIGHT TO TOP OF PROPOSED DEVELOPMENT(in meters)

You have provided us with the coordinates, we will just require point 2&3.

Kind Regards,

Simphiwe Masilela
Obstacle Evaluator | ATM
ATNS Head Office, Bruma, Johannesburg, South Africa

T: 011 607 1228 • F: 011 607 1466 • C:
E: SimphiweM@atns.co.za • W: www.atns.co.za



[View Disclaimer](#)

From: Hlengiwe Ntuli [mailto:HlengiweN@sivest.co.za]
Sent: Tuesday, February 09, 2016 2:23 PM
Subject: Two Proposed Tlisitseng Solar Photovoltaic Energy Facilities: DSR Comment Period Ending
Importance: High

***** Please note that this email was sent from a NO REPLY email address. Please do not reply to this address as it is an unmonitored email account. *****

Dear Interested and/or Affected Party

ENVIRONMENTAL IMPACT ASSESSMENTS (EIAs) AND ENVIRONMENTAL MANAGEMENT PROGRAMMES (EMPrs) FOR THE PROPOSED DEVELOPMENT OF THE TWO (2) TLISITSENG 75MW SOLAR PHOTOVOLTAIC (PV) ENERGY FACILITIES, NEAR LICHTENBURG, NORTH WEST PROVINCE (DEA REFERENCE NUMBERS TO BE CONFIRMED)

SiVEST sent the Draft Scoping Report for the proposed Tlisitseng Solar PV near Lichtenburg to your Department on 11 January 2016 for comment (refer to the attached email). Please can you advise if comments will be submitted to us for inclusion in the Final Scoping Report.

We would like to inform you that, the comment period for state departments is ending **today** and you are advised to send your comments to us before **Friday 12 February 2016**.

Kind Regards,

Hlengiwe Ntuli
Projects Secretary
SiVEST Environmental & Civils Divisions



SiVEST is a Level 3 BBBEE Contributor

Direct +27 11 798 0690 Tel +27 11 798 0600 fax +27 11 803 7272
email HlengiweN@sivest.co.za website www.sivest.co.za



Consulting Engineers - Project Managers - Environmental Consultants - Town and Regional Planners
Durban - Johannesburg - Pietermaritzburg - Richards Bay - Ladysmith - Cape Town - Harare (Zimbabwe)

Disclaimer

The information contained in this communication from the sender is confidential. It is intended solely for use by the recipient and others authorized to receive it. If you are not the recipient, you are hereby notified that any disclosure, copying, distribution or taking action in relation of the contents of this information is strictly prohibited and may be unlawful.

This email has been scanned for viruses and malware, and automatically archived by Mimecast SA (Pty) Ltd, an innovator in Software as a Service (SaaS) for business. Mimecast Unified Email Management ??? (UEM) offers email continuity, security, archiving and compliance with all current legislation. To find out more, [contact Mimecast](#).

The contents of this email are confidential and intended for the named recipient(s) only. The information may be privileged or otherwise protected from disclosure. The views expressed in this message are those of the sender, unless otherwise stated to be. This email is also subject to copyright. No part hereof may be reproduced, adapted, transmitted, or used in any way without the written consent of ATNS SOC Limited. Please do not hesitate to contact us immediately should you have any doubts regarding the authenticity of an email purportedly sent by the sender.

Hlengiwe Ntuli

From: Dineo Doreen Mogonediwa <ddmogonediwa@nwpg.gov.za>
Sent: 12 February 2016 12:44 PM
To: Hlengiwe Ntuli
Subject: RE: FW: Two Proposed Tlisitseng Solar Photovoltaic Energy Facilities: DSR Comment Period Ending

Afternoon

I dont have anything as yet due to the fact that Mr. Mafune is still not in the office and he will only be here on Monday.

Regards,

Dineo

>>> Hlengiwe Ntuli <HlengiweN@sivest.co.za> 2016/02/12 12:40 PM >>>
Good Day Dineo,

Do you have any feedback regarding this?

Kind Regards,

Hlengiwe Ntuli
Projects Secretary
SIVEST Environmental & Civils Divisions



SIVEST is a Level 3 BBBEE Contributor

Direct +27 11 798 0690 **Tel** +27 11 798 0600 **fax** +27 11 803 7272
email HlengiweN@sivest.co.za **website** www.sivest.co.za

Consulting Engineers - Project Managers - Environmental Consultants - Town and Regional Planners
Durban - Johannesburg - Pietermaritzburg - Richards Bay - Ladysmith - Cape Town - Harare (Zimbabwe)

From: Dineo Doreen Mogonediwa [mailto:ddmogonediwa@nwpg.gov.za]
Sent: 10 February 2016 12:25 PM
To: Hlengiwe Ntuli <HlengiweN@sivest.co.za>
Subject: Re: FW: Two Proposed Tlisitseng Solar Photovoltaic Energy Facilities: DSR Comment Period Ending

Afternoon

Your e-mail is received and will be forwarded to Mr. Mafune.

Regards,

Dineo Mogonediwa

>>> Hlengiwe Ntuli <HlengiweN@sivest.co.za> 2016/02/10 12:17 PM >>>

***** Please note that this email was sent from a NO REPLY email address. Please do not reply to this address as it is an unmonitored email account. *****

Dear Interested and/or Affected Party

ENVIRONMENTAL IMPACT ASSESSMENTS (EIAs) AND ENVIRONMENTAL MANAGEMENT PROGRAMMES (EMPrs) FOR THE PROPOSED DEVELOPMENT OF THE TWO (2) TLISITSENG 75MW SOLAR PHOTOVOLTAIC (PV) ENERGY FACILITIES, NEAR LICHTENBURG, NORTH WEST PROVINCE (DEA REFERENCE NUMBERS TO BE CONFIRMED)

SiVEST sent the Draft Scoping Report for the proposed Trisitseng Solar PV near Lichtenburg to your Department on 11 January 2016 for comment (refer to the attached email). Please can you advise if comments will be submitted to us for inclusion in the Final Scoping Report.

We would like to inform you that, the comment period for state departments has ended on **9 February** and you are advised to send your comments to us before **Friday 12 February 2016**.

Kind Regards,

Hlengiwe Ntuli
Projects Secretary
SiVEST Environmental & Civils Divisions



SiVEST is a Level 3 BBBEE Contributor

Direct +27 11 798 0690 **Tel** +27 11 798 0600 **fax** +27 11 803 7272
email HlengiweN@sivest.co.za **website** www.sivest.co.za

Consulting Engineers - Project Managers - Environmental Consultants - Town and Regional Planners
Durban - Johannesburg - Pietermaritzburg - Richards Bay - Ladysmith - Cape Town - Harare (Zimbabwe)

Disclaimer

The information contained in this communication from the sender is confidential. It is intended solely for use by the recipient and others authorized to receive it. If you are not the recipient, you are hereby notified that any disclosure, copying, distribution or taking action in relation of the contents of this information is strictly prohibited and may be unlawful.

This email has been scanned for viruses and malware, and automatically archived by Mimecast SA (Pty) Ltd, an innovator in Software as a Service (SaaS) for business. Mimecast Unified Email Management ??? (UEM) offers email continuity, security, archiving and compliance with all current legislation. To find out more, [contact Mimecast](#).

Disclaimer

The information contained in this communication from the sender is confidential. It is intended solely for use by the recipient and others authorized to receive it. If you are not the recipient, you are hereby notified that any disclosure, copying, distribution or taking action in relation of the contents of this information is strictly prohibited and may be unlawful.

This email has been scanned for viruses and malware, and automatically archived by Mimecast SA (Pty) Ltd, an innovator in Software as a Service (SaaS) for business. Mimecast Unified Email Management ??? (UEM) offers email continuity, security, archiving and compliance with all current legislation. To find out more, [contact Mimecast](#).

**energy**

Department:
Energy
REPUBLIC OF SOUTH AFRICA

Enquiries: Mr Pheladi Masipa, E-mail: Pheladi.Masipa@energy.gov.za
Private Bag X96, Pretoria 0001, Tel: 012 406 7650, Fax: 012 323 5819

Ms Andrea Gibb

SiVEST

P.O. Box 2921

Rivonia

2128

Tel: +27 (0)11 798 0600

E-mail: andreaq@sivest.co.za

Dear Ms Gibb

RE: DRAFT SCOPING REPORT FOR THE PROPOSED CONSTRUCTION OF THE TLISITSENG 75MW SOLAR PHOTOVOLTAIC (PV) ENERGY FACILITY NEAR LICHTENBURG, NORTH WEST PROVINCE

The Department of Energy hereby acknowledges receipt of the Draft Scoping Report for the proposed construction of the Tlisitseng 75MW Solar Photovoltaic (PV) Energy facility near Lichtenburg, North West Province

We would like to confirm that the Department will be inviting Independent Power Producers to submit proposals for the generation of electricity from renewable energy sources under the Renewable Energy Independent Power Producer Procurement Programme (REIPPPP) during the second quarter of 2016.

We have gone through the report and wish to SiVEST that we have no comments on the report. We further wish you all the best in securing a positive Environmental Authorization from the Department of Environmental Affairs.

The Department would appreciate being kept informed of progress with this project.

Should you need any energy policy related information or clarity, kindly contact: Mr Pheladi Masipa on 012 406 7650 or please send your query to Pheladi.Masipa@energy.gov.za.

Yours sincerely,



Mr P. MASIPA, Pr.Sci.Nat.

PROJECT COORDINATOR: RENEWABLE ENERGY INITIATIVES

DATE: 15/02/2016

Hlengiwe Ntuli

From: Lourens Leeuwner <lourensl@ewt.org.za>
Sent: 16 February 2016 11:56 AM
To: Hlengiwe Ntuli
Subject: RE: Two Proposed Tlisitseng Solar Photovoltaic Energy Facilities: DSR Comment Period Ending

Hi Hlengiwe

I have reviewed the Avifaunal specialist report. We have no comments at this stage.

Please keep the EWT up to date with further correspondence regarding this development. Thank you.

Regards

Lourens Leeuwner
Renewable Energy Project Manager
Endangered Wildlife Trust
W + 27 21 788 5661 | C + 27 72 775 5111
Email: lourensl@ewt.org.za | Web: www.ewt.org.za | Skype: lourenslleeuwner

Physical Address: 86 Capricorn Drive, Capricorn Business Park, Muizenberg, Cape Town



Physical Address: Building K2, Pinelands Office Park, Ardeer Road, Modderfontein, 1609
Postal Address: Private Bag X11, Modderfontein, 1645, Johannesburg, South Africa
GPS Co-ordinates: S 26° 05.591' | E 28° 09.247'
Tell: +27 11 372 3600 Fax: +27 11 608 4682

ENDANGERED WILDLIFE TRUST
www.ewt.org.za

Subscribe to EWTALK Newsletter

THE SMALLEST DONATION CAN MAKE A DIFFERENCE

This E-mail message and its attachments are subject to the disclaimer published at <http://www.ewt.org.za>.

From: Hlengiwe Ntuli [mailto:HlengiweN@sivest.co.za]
Sent: Wednesday, February 10, 2016 2:10 PM
To: Lourens Leeuwner <lourensl@ewt.org.za>
Subject: FW: Two Proposed Tlisitseng Solar Photovoltaic Energy Facilities: DSR Comment Period Ending
Importance: High

Good Day Lourens,

As discussed via telephone, please respond to us your written comment for the project even if you do not have a comment.

Kind Regards,

Hlengiwe Ntuli
Projects Secretary
SiVEST Environmental & Civils Divisions



SiVEST is a Level 3 BBBEE Contributor



Consulting Engineers - Project Managers - Environmental Consultants - Town and Regional Planners
Durban - Johannesburg - Pietermaritzburg - Richards Bay - Ladysmith - Cape Town - Harare (Zimbabwe)

***** Please note that this email was sent from a NO REPLY email address. Please do not reply to this address as it is an unmonitored email account. *****

Dear Interested and/or Affected Party

ENVIRONMENTAL IMPACT ASSESSMENTS (EIAs) AND ENVIRONMENTAL MANAGEMENT PROGRAMMES (EMPrs) FOR THE PROPOSED DEVELOPMENT OF THE TWO (2) TLISITSENG 75MW SOLAR PHOTOVOLTAIC (PV) ENERGY FACILITIES, NEAR LICHTENBURG, NORTH WEST PROVINCE (DEA REFERENCE NUMBERS TO BE CONFIRMED)

SiVEST sent the Draft Scoping Report for the proposed Tlisitseng Solar PV near Lichtenburg to your Department on 11 January 2016 for comment (refer to the attached email). Please can you advise if comments will be submitted to us for inclusion in the Final Scoping Report.

We would like to inform you that, the comment period for state departments has ended on **9 February** and you are advised to send your comments to us before **Friday 12 February 2016**.

Kind Regards,

Hlengiwe Ntuli
Projects Secretary
SiVEST Environmental & Civils Divisions



SiVEST is a Level 3 BBBEE Contributor



Consulting Engineers - Project Managers - Environmental Consultants - Town and Regional Planners
Durban - Johannesburg - Pietermaritzburg - Richards Bay - Ladysmith - Cape Town - Harare (Zimbabwe)

Disclaimer

The information contained in this communication from the sender is confidential. It is intended solely for use by the recipient and others authorized to receive it. If you are not the recipient, you are hereby notified that any disclosure, copying, distribution or taking action in relation of the contents of this information is strictly prohibited and may be unlawful.

This email has been scanned for viruses and malware, and automatically archived by Mimecast SA (Pty) Ltd, an innovator in Software as a Service (SaaS) for business. Mimecast Unified Email Management ??? (UEM) offers email continuity, security, archiving and compliance with all current legislation. To find out more, [contact Mimecast](#).

Lynsey Rimbault

From: Hlengiwe Ntuli
Sent: 22 February 2016 11:01
To: Lynsey Rimbault
Subject: FW: Tlisitseng Solar PV projects Final Scoping Reports submitted to the DEA

FYA

Kind Regards,

Hlengiwe Ntuli
Projects Secretary
SiVEST Environmental & Civils Divisions



SiVEST is a Level 3 BBBEE Contributor

Direct +27 11 798 0690 **Tel** +27 11 798 0600 **fax** +27 11 803 7272
email HlengiweN@sivest.co.za **website** www.sivest.co.za



Consulting Engineers - Project Managers - Environmental Consultants - Town and Regional Planners
Durban - Johannesburg - Pietermaritzburg - Richards Bay - Ladysmith - Cape Town - Harare (Zimbabwe)

From: John Geeringh [mailto:GeerinJH@eskom.co.za]
Sent: 22 February 2016 10:51 AM
To: Hlengiwe Ntuli <HlengiweN@sivest.co.za>
Subject: RE: Tlisitseng Solar PV projects Final Scoping Reports submitted to the DEA

Can you please send me KMZ files of the sites, layouts and line routes for the proposed power lines for my records and proper checking against our plans. Can you also send me the Sendawo KMZ files? I would appreciate it very much.

Regards
John

From: Hlengiwe Ntuli [mailto:HlengiweN@sivest.co.za]
Sent: 19 February 2016 03:48 PM
Cc: Rebecca Thomas; Lynsey Rimbault; nicolenev@zitholele.co.za
Subject: Tlisitseng Solar PV projects Final Scoping Reports submitted to the DEA

***** Please note that this email was sent from a NO REPLY email address. Please do not reply to this address as it is an unmonitored email account. *****

Dear Interested and/or Affected Party

ENVIRONMENTAL IMPACT ASSESSMENT (EIA) AND ENVIRONMENTAL MANAGEMENT PROGRAMME (EMPr) FOR THE TWO TLISITSENG SOLAR PHOTOVOLTAIC (PV) ENERGY FACILITIES NEAR LICHTENBURG, NORTH WEST PROVINCE

DEA Ref. TLISITSENG PV SOLAR 1: 14/12/16/3/3/2/889

* FSR AVAILABLE FOR REVIEW

We wish to express our appreciation to the stakeholders who submitted comments on the Draft Scoping Reports (DSRs) for the above mentioned proposed projects during the public review period (Monday 11 January 2016 to Tuesday 9 February 2016). After the public review period, the DSRs were updated, taking into consideration the issues and concerns raised by stakeholders.

The Final Scoping Reports (FSRs) were submitted to the Department of Environmental Affairs (DEA) for their consideration on Friday 19 February 2016.

In accordance with the National Environmental Management Act (NEMA), the FSRs will be available for public comment and review from Monday 22 February 2016 to Monday 7 March 2016 (end of business day). The FSRs are available on SiVEST's website: <http://www.sivest.co.za/> click on 'Downloads' (top right), then scroll down to 13303 Tlisitseng PV Energy Development. Alternatively, please contact SiVEST to obtain an electronic copy of the reports on CD.

Should you have any comments on the FSRs, please submit these in writing directly to the DEA on or before Monday 7 March 2016 (close of business day):

Department of Environmental Affairs (DEA)
Ms. Mmamohale Kabasa
Private Bag X447
PRETORIA
0001
Tel: 012 399 9420
Email: MKabasa@environment.gov.za

As per the EIA Regulations, please send a copy of your comments to the SiVEST Office at the following address:

SiVEST Environmental
Lynsey Rimbault
PO BOX 2921
Rivonia
2128
Tel: 011 798 0600
Fax: 011 803 7272
Email: lynseyr@sivest.co.za

Kind Regards,

REBECCA THOMAS (B.Sc Env. Sc.; PDM Business Management)
Senior Environmental Scientist
SiVEST Environmental Division

SiVEST is a Level 3 BBBEE Contributor

direct +27 11 798 0634 tel +27 11 798 0600 fax +27 11 803 7272 cell +27 82 302 9010
email rebeccat@sivest.co.za website www.sivest.co.za

Consulting Engineers - Project Managers - Environmental Consultants - Town and Regional Planners
Durban - Johannesburg - Pietermaritzburg - Richards Bay - Ladysmith - Cape Town - Harare (Zimbabwe)

Disclaimer

The information contained in this communication from the sender is confidential. It is intended solely for use by the recipient and others authorized to receive it. If you are not the recipient, you are hereby notified that any disclosure, copying, distribution or taking action in relation of the contents of this information is strictly prohibited and may be unlawful.

This email has been scanned for viruses and malware, and automatically archived by Mimecast SA (Pty) Ltd, an innovator in Software as a Service (SaaS) for business. Mimecast Unified Email Management ??? (UEM) offers email continuity, security, archiving and compliance with all current legislation. To find out more, [contact Mimecast](#).

I'm part of the 49Million initiative...

<http://www.49Million.co.za>

NB: This Email and its contents are subject to the Eskom Holdings SOC Limited EMAIL LEGAL NOTICE which can be viewed at http://www.eskom.co.za/Pages/Email_Legal_Spam_Disclaimer.aspx

Hlengiwe Ntuli

From: Annette Van Zyl-Swart (A) <VZylA7@telkom.co.za>
Sent: 22 February 2016 09:15 AM
To: Hlengiwe Ntuli
Cc: Johan Ferreira (JP)
Subject: FW: Tlisitseng Solar PV projects Final Scoping Reports submitted to the DEA

Goodday,

Can we have a sketch and letter for this application of yours.
Will you need indication of where our infrastructure is?

Regards,

Annette van Zyl-Swart

Planner (Highload Clearances, Wayleave & Poles SPOC MMB DSSU)

Openserve – 30 Electron Rd Uraniaville, Klerksdorp

Tel – 018 469 6517

Cell – 081 536 4727

Fax to Email – 086 569 8345

Office Fax – 018 469 6528

vzyla7@telkom.co.za



From: Chris Nthaudi (MC)
Sent: Friday, February 19, 2016 3:51 PM
To: Hlengiwe Ntuli; Annette Van Zyl-Swart (A)
Cc: Rebecca Thomas; Lynsey Rimbault; nicolenev@zitholele.co.za
Subject: RE: Tlisitseng Solar PV projects Final Scoping Reports submitted to the DEA

From: Hlengiwe Ntuli [<mailto:HlengiweN@sivest.co.za>]
Sent: 19 February 2016 03:48 PM
Cc: Rebecca Thomas; Lynsey Rimbault; nicolenev@zitholele.co.za
Subject: Tlisitseng Solar PV projects Final Scoping Reports submitted to the DEA

***** Please note that this email was sent from a NO REPLY email address. Please do not reply to this address as it is an unmonitored email account. *****

Dear Interested and/or Affected Party

ENVIRONMENTAL IMPACT ASSESSMENT (EIA) AND ENVIRONMENTAL MANAGEMENT PROGRAMME (EMPr) FOR THE TWO TLISITSENG SOLAR PHOTOVOLTAIC (PV) ENERGY FACILITIES NEAR LICHTENBURG, NORTH WEST PROVINCE

DEA Ref. TLISITSENG PV SOLAR 1: 14/12/16/3/3/2/889
TLISITSENG PV SOLAR 2: 14/12/16/3/3/2/890

* FSR AVAILABLE FOR REVIEW

We wish to express our appreciation to the stakeholders who submitted comments on the Draft Scoping Reports (DSRs) for the above mentioned proposed projects during the public review period (Monday 11 January 2016 to Tuesday 9 February 2016). After the public review period, the DSRs were updated, taking into consideration the issues and concerns raised by stakeholders.

The Final Scoping Reports (FSRs) were submitted to the Department of Environmental Affairs (DEA) for their consideration on Friday 19 February 2016.

In accordance with the National Environmental Management Act (NEMA), the FSRs will be available for public comment and review from Monday 22 February 2016 to Monday 7 March 2016 (end of business day). The FSRs are available on SiVEST's website: <http://www.sivest.co.za/> click on 'Downloads' (top right), then scroll down to 13303 Tlisitseng PV Energy Development. Alternatively, please contact SiVEST to obtain an electronic copy of the reports on CD.

Should you have any comments on the FSRs, please submit these in writing directly to the DEA on or before Monday 7 March 2016 (close of business day):

Department of Environmental Affairs (DEA)
Ms. Mmamohale Kabasa
Private Bag X447
PRETORIA
0001
Tel: 012 399 9420
Email: MKabasa@environment.gov.za

As per the EIA Regulations, please send a copy of your comments to the SiVEST Office at the following address:

SiVEST Environmental
Lynsey Rimbault
PO BOX 2921
Rivonia
2128
Tel: 011 798 0600
Fax: 011 803 7272
Email: lynseyr@sivest.co.za

Kind Regards,

REBECCA THOMAS (B.Sc Env. Sc.; PDM Business Management)
Senior Environmental Scientist
SiVEST Environmental Division

SiVEST is a Level 3 BBBEE Contributor

direct +27 11 798 0634 tel +27 11 798 0600 fax +27 11 803 7272 cell +27 82 302 9010

email rebeccat@sivest.co.za website www.sivest.co.za

**Consulting Engineers - Project Managers - Environmental Consultants - Town and Regional Planners
Durban - Johannesburg - Pietermaritzburg - Richards Bay - Ladysmith - Cape Town - Harare (Zimbabwe)**

Disclaimer

The information contained in this communication from the sender is confidential. It is intended solely for use by the recipient and others authorized to receive it. If you are not the recipient, you are hereby notified that any disclosure, copying, distribution or taking action in relation of the contents of this information is strictly prohibited and may be unlawful.

This email has been scanned for viruses and malware, and automatically archived by Mimecast SA (Pty) Ltd, an innovator in Software as a Service (SaaS) for business. Mimecast Unified Email Management (UEM) offers email continuity, security, archiving and compliance with all current legislation. To find out more, [contact Mimecast](#).

~~~~~  
This e-mail is subject to the Telkom SA SOC Ltd electronic communication legal notice,  
available at : <http://www.telkom.co.za/TelkomEMailLegalNotice.PDF>  
~~~~~

Lynsey Rimbault

From: Jan Oliver (NR) <OliverJ@nra.co.za>
Sent: 08 March 2016 09:28
To: Hlengiwe Ntuli
Subject: RE: Tlisitseng PV Public Meeting Invitation

Dear Hlengiwe Ntuli

SANRAL is only interested in the locality of the facilities, substations and power lines, in order to comment on access to the facilities and to determine if any national road is affected. We are not interested in the environmental aspects and supports the approval of Basic Assessment by the relevant authority. We further will not attend public hearings due to time constraints.

Yours sincerely,

Jan Oliver

Statutory Control Section

The South African National Road Agency SOC Limited

Northern Regional Office

38 Ida Street, Menlo Park, Pretoria, 0081

Private Bag X17, Lynnwood Ridge, 0040

Tel: (012) 426 - 6242

Fax: (012) 348 - 1512

Cell: 083 283 6083

e-Mail: oliverj@nra.co.za

www: www.sanral.co.za

From: Hlengiwe Ntuli [mailto:HlengiweN@sivest.co.za]

Sent: 07 March 2016 06:10 PM

Cc: Rebecca Thomas <RebeccaT@sivest.co.za>; Lynsey Rimbault <LynseyR@sivest.co.za>; nicolenev@zitholele.co.za

Subject: Tlisitseng PV Public Meeting Invitation

***** Please note that this email was sent from a NO REPLY email address. Please do not reply to this address as it is an unmonitored email account. *****

Dear Interested and Affected Party,

ENVIRONMENTAL IMPACT ASSESSMENT (EIA) AND ENVIRONMENTAL MANAGEMENT PROGRAMME (EMPr) FOR THE TWO TLISITSENG SOLAR PHOTOVOLTAIC (PV) ENERGY FACILITIES, AND BASIC ASSESSMENTS (BA) FOR THE ASSOCIATED SUBSTATIONS AND POWER LINES, NEAR LICHTENBURG, NORTH WEST PROVINCE

DEA Ref. TLISITSENG PV SOLAR 1: 14/12/16/3/3/2/889

TLISITSENG PV SOLAR 2: 14/12/16/3/3/2/890

TLISITSENG 1 SUBSTATION AND POWER LINE: To be confirmed

TLISITSENG 2 SUBSTATION AND POWER LINE: To be confirmed

. INVITATION TO PUBLIC MEETING

We would like to take this opportunity to invite you to attend the Public Meeting that will be held for the above-mentioned proposed project on:

DATE TIMES VENUES

Monday, 14 March 2016 Starts at: 18h00

Registration from: 17h45 Lichtenburg Town Hall / Soepe Hall, on Nelson Mandela Drive, Lichtenburg

To ensure that sufficient seating is provided at the venue, we kindly request that you complete the attached Registration Form and return it to the Public Participation team on or before Thursday, 10 March 2016.

The purpose of the Public Meeting is outlined in the attached draft agenda.

Your input into this EIA process is highly valued as it will help identify, and if required address, any environmental impacts that may be associated with this proposed project during the Scoping phase.

We encourage you to attend and participate in the Public Meeting and thank you in anticipation for your active and meaningful contribution to the EIA process.

Beste Belangstellende en/of Geaffekteerde Party,

OMGEWINGSIMPAAKEVALUERING (OIE) EN OMGEWINGSBESTUURSPROGRAM (OBPr) VIR DIE VOORGESTELDE ONTWIKKELING VAN DIE TWEE (2) TLISITSENG 75MW FOTOVOLTAÏESE (FV) SONKRAGAANLEGTE, EN BASIESE EVALUERING (BE) VIR DIE GEASSOSIEERDE 132kV KRAGLYNE NABY LICHTENBURG, NOORDWES PROVINSIE

DO Verw. No. TLISITSENG PV SOLAR 1: 14/12/16/3/3/2/889

TLISITSENG PV SOLAR 2: 14/12/16/3/3/2/890

TLISITSENG 1 SUBSTATION AND POWER LINE: Ter bevestiging

TLISITSENG 2 SUBSTATION AND POWER LINE: Ter bevestiging

. UITNODIGING NA PUBLIEKEVERGADERING

Ons maak graag van hierdie geleentheid gebruik om u uit te nooi om die Publiekevergadering wat vir die bogenoemde voorgestelde projek gehou word op:

DATUM TYD PLEK

Maandag, 14 Maart 2016 Begin om: 18h00

Registrasie vanaf: 17h45 Lichtenburg Town Hall / Soepe Hall, Nelson Mandela Drive, Lichtenburg

Om te verseker dat ons voorsiening maak vir alle teenwoordiges, versoek ons u vriendelik om die ingeslote Registrasievorm te voltooi en aan die Openbare Deelname span te stuur voor of op Donderdag, 10 Maart 2016.

Die doel van die Publiekevergadering is vervat in die ingeslote konsep agenda.

U insette in die OIS-proses word hoog op prys gestel aangesien dit sal bydrae tot die identifisering van, en indien nodig die gepaardgaande ondersoek tydens die Bestekopnamefase, van enige omgewingsimpakte wat met hierdie voorgestelde projek geassosieer mag word.

Ons moedig u bywoning en deelname by die Publiekevergadering aan en dank u byvoorbeeld vir u aktiewe en betekenisvolle bydrae tot die OIS-proses.

REBECCA THOMAS (B.Sc Env. Sc.; PDM Business Management) Senior Environmental Scientist
SiVEST Environmental Division

SiVEST is a Level 3 BBBEE Contributor

direct +27 11 798 0634 tel +27 11 798 0600 fax +27 11 803 7272 cell +27 82 302 9010
email rebeccat@sivest.co.za website www.sivest.co.za

Consulting Engineers - Project Managers - Environmental Consultants - Town and Regional Planners
Durban - Johannesburg - Pietermaritzburg - Richards Bay - Ladysmith - Cape Town - Harare (Zimbabwe)

SiVEST is a Level 3 BBBEE Contributor

Direct +27 11 798 0691 Tel +27 11 798 0600 fax +27 11 803 7272 cell +27 72 779 4899
email shaunt@sivest.co.za website www.sivest.co.za

Consulting Engineers - Project Managers - Environmental Consultants - Town and Regional Planners
Durban - Johannesburg - Pietermaritzburg - Richards Bay - Ladysmith - Cape Town - Harare (Zimbabwe)

Disclaimer

The information contained in this communication from the sender is confidential. It is intended solely for use by the recipient and others authorized to receive it. If you are not the recipient, you are hereby notified that any disclosure, copying, distribution or taking action in relation of the contents of this information is strictly prohibited and may be unlawful.

This email has been scanned for viruses and malware, and automatically archived by Mimecast SA (Pty) Ltd, an innovator in Software as a Service (SaaS) for business. Mimecast Unified Email Management ??? (UEM) offers email continuity, security, archiving and compliance with all current legislation. To find out more, [contact Mimecast](#).

Disclaimer:

This message contains confidential information and is intended only for the individual named.

If you are not the named addressee you should not disseminate, distribute or copy this e-mail.

Please notify the sender immediately by e-mail if you have received this e-mail by mistake and delete this e-mail from your system. E-mail transmission cannot be guaranteed to be secure or without errors as information could be intercepted, corrupted, lost, destroyed, arrive late or incomplete, or contain viruses.

The sender therefore does not accept liability for any errors or omissions in the contents of this message, which arise as a result of e-mail transmission.

If verification is required please request a hard-copy version. The South African National Roads Agency SOC Ltd, PO Box 415, Pretoria, 0001, South Africa, Tel +27-(0)12 844 8000, www.nra.co.za.

This Disclaimer is deemed to form part of the content of this email in terms of Section 11 of the Electronic Communications and Transactions Act, 25 of 2002.

Lynsey Rimbault

From: Jan Oliver (NR) <OliverJ@nra.co.za>
Sent: 08 March 2016 09:24
To: Hlengiwe Ntuli
Subject: RE: Tlisitseng PV Focus Group Meeting

Dear Rebecca Thomas / Hlengiwe Ntuli

Please email me a locality map showing the location and extent of the two Tlisitseng Solar energy to see whether any national road is affected or not.

Yours sincerely,

Jan Oliver

Statutory Control Section

The South African National Road Agency SOC Limited

Northern Regional Office

38 Ida Street, Menlo Park, Pretoria, 0081

Private Bag X17, Lynnwood Ridge, 0040

Tel: (012) 426 - 6242

Fax: (012) 348 - 1512

Cell: 083 283 6083

e-Mail: oliverj@nra.co.za

www: www.sanral.co.za

From: Hlengiwe Ntuli [mailto:HlengiweN@sivest.co.za]

Sent: 07 March 2016 06:17 PM

To: Rebecca Thomas <RebeccaT@sivest.co.za>; Lynsey Rimbault <LynseyR@sivest.co.za>; nicolenev@zitholele.co.za

Cc: 'Kobus Visser' <kobus@agrisa.co.za>; 'Simphiwe Masilela' <SimphiweM@atns.co.za>; 'Johanna Morobane' <JohannaM@atns.co.za>; 'Simon Gear' <advocacy@birdlife.org.za>; 'Godfrey Samore' <gsamore@nwpg.gov.za>; 'Mashudu Marubini' <MashuduMa@daff.gov.za>; 'Anneliza Collett' <annelizac@nda.agric.za>; 'Thoko Buthelezi' <ThokoB@nda.agric.za>; 'Pheladi Masipa' <Pheladi.Masipa@energy.gov.za>; 'Lerato April' <Lerato.April@energy.gov.za>; 'Seoka Lekota' <slekota@environment.co.za>; 'Mmatlala Rabothata' <mrabothata@environment.co.za>; 'Pieter Swart' <Pieter.Swart@dmr.gov.za>; 'Doris Maumela' <MaumelaD@dws.gov.za>; 'Lesego Holele' <lerato.diseko@gmail.com>; 'Pogiso Maitshotlo' <pjmaitshotlo@gmail.com>; 'J Molefe' <digoamajel@mitsobotla.co.za>; 'KRJ Zandamela' <info@mitsobotla.gov.za>; 'John Geeringh' <GeerinJH@eskom.co.za>; 'Lourens Leeuwner' <lourensl@ewt.org.za>; 'Mpho Phiri' <phirim@nwpg.gov.za>; 'M W Moholatsi' <fetshangm@moseskotane.co.za>; 'Lehlohonolo March' <matsosel@nmmdm.gov.za>; 'Nono Dince' <gopanel@nmmdm.gov.za>; 'Yoliswa Sechoaro' <msbole@nwpg.gov.za>; 'Alfred Mafune' <ddmogonediswa@nwpg.gov.za>; 'Matshediso Mahlaku' <Matshediso.mahlaku@energy.gov.za>; 'Tebogo Sethosa' <Tebogo.sethosa@energy.gov.za>; 'Bonolo Mohlakoana' <bmohlakoana@nwpg.gov.za>; 'SM Matsheka' <MatshekaS@dwa.gov.za>; 'Lizell Stroh' <strohl@caa.co.za>; 'Harry Roberts' <Robertsh@caa.co.za>; Jan Oliver (NR) <OliverJ@nra.co.za>; Shaun Dyers (WR) <DyersS@nra.co.za>; 'Johan Koegelenberg' <koegelenbergj@sentech.co.za>; 'Chris Nthaudi' <NthaudMC@telkom.co.za>; 'Annette Van Zyl-Swart' <VZYIA7@telkom.co.za>; 'Sam Fiff' <Francis.Rahlapane@transnet.net>; 'Suzanne Erasmus' <info@wessa.co.za>; 'Morgan Griffiths' <morgan.griffiths@wessa.co.za>

Subject: Tlisitseng PV Focus Group Meeting

***** Please note that this email was sent from a NO REPLY email address. Please do not reply to this address as it is an unmonitored email account. *****

Dear Stakeholder,

ENVIRONMENTAL IMPACT ASSESSMENT (EIA) AND ENVIRONMENTAL MANAGEMENT PROGRAMME (EMPr) FOR THE TWO TLISITSENG SOLAR PHOTOVOLTAIC (PV) ENERGY FACILITIES, AND BASIC ASSESSMENTS (BA) FOR THE ASSOCIATED SUBSTATIONS AND POWER LINES, NEAR LICHTENBURG, NORTH WEST PROVINCE

DEA Ref. TLISITSENG PV SOLAR 1: 14/12/16/3/3/2/889

TLISITSENG PV SOLAR 2: 14/12/16/3/3/2/890

TLISITSENG 1 SUBSTATION AND POWER LINE: To be confirmed

TLISITSENG 2 SUBSTATION AND POWER LINE: To be confirmed

• INVITATION TO FOCUS GROUP MEETING

This letter serves to cordially invite you to attend a Focus Group Meeting (FGM) that will be held on:

DATE: Monday, 14 March 2016

TIME: 14h00

VENUE: Auditorium of the Ditsobotla Local Municipality Library, Civic Centre, Cnr Nelson Mandela and Transvaal Streets, Lichtenburg

This FGM is part of the Environmental Impact Assessment (EIA) processes being undertaken by SiVEST for the above mentioned projects.

As stakeholder we would value your attendance at the FGM. The purpose of this FGM is to:

- ♣ provide feedback on the impact phase environmental findings;
- ♣ provide the opportunity to raise any questions for clarifications regarding the environmental findings;
- ♣ provide the opportunity to raise any comments and/or concerns regarding this proposed project; and
- ♣ record your comments and/or concerns raised at the FGM.

To ensure that sufficient seating is provided at the venue, we kindly request that you complete the attached Registration Form and return it to the Public Participation team on or before Thursday, 10 March 2016.

Please also note that a Public Meeting is being held on the evening of Monday, 14 March 2016 at Lichtenburg Town Hall / Soepe Hall on Nelson Mandela Drive, Lichtenburg at 18h00.

Please feel free to pass this invitation to any other relevant officials from your Department as you deem necessary. We are looking forward to your attendance and meaningful contributions.

Kind Regards,

REBECCA THOMAS (B.Sc Env. Sc.; PDM Business Management) Senior Environmental Scientist
SiVEST Environmental Division

SiVEST is a Level 3 BBBEE Contributor

direct +27 11 798 0634 tel +27 11 798 0600 fax +27 11 803 7272 cell +27 82 302 9010
email rebeccat@sivest.co.za website www.sivest.co.za

Consulting Engineers - Project Managers - Environmental Consultants - Town and Regional Planners
Durban - Johannesburg - Pietermaritzburg - Richards Bay - Ladysmith - Cape Town - Harare (Zimbabwe)

SiVEST is a Level 3 BBBEE Contributor

Direct +27 11 798 0691 Tel +27 11 798 0600 fax +27 11 803 7272 cell +27 72 779 4899
email shaunt@sivest.co.za website www.sivest.co.za

Consulting Engineers - Project Managers - Environmental Consultants - Town and Regional Planners
Durban - Johannesburg - Pietermaritzburg - Richards Bay - Ladysmith - Cape Town - Harare (Zimbabwe)

Disclaimer

The information contained in this communication from the sender is confidential. It is intended solely for use by the recipient and others authorized to receive it. If you are not the recipient, you are hereby notified that any disclosure, copying, distribution or taking action in relation of the contents of this information is strictly prohibited and may be unlawful.

This email has been scanned for viruses and malware, and automatically archived by Mimecast SA (Pty) Ltd, an innovator in Software as a Service (SaaS) for business. Mimecast Unified Email Management ??? (UEM) offers email continuity, security, archiving and compliance with all current legislation. To find out more, [contact Mimecast](#).

Disclaimer:

This message contains confidential information and is intended only for the individual named.

If you are not the named addressee you should not disseminate, distribute or copy this e-mail.

Please notify the sender immediately by e-mail if you have received this e-mail by mistake and delete this e-mail from your system. E-mail transmission cannot be guaranteed to be secure or without errors as information could be intercepted, corrupted, lost, destroyed, arrive late or incomplete, or contain viruses.

The sender therefore does not accept liability for any errors or omissions in the contents of this message, which arise as a result of e-mail transmission.

If verification is required please request a hard-copy version. The South African National Roads Agency SOC Ltd, PO Box 415, Pretoria, 0001, South Africa, Tel +27-(0)12 844 8000, www.nra.co.za.

This Disclaimer is deemed to form part of the content of this email in terms of Section 11 of the Electronic Communications and Transactions Act, 25 of 2002.



Lynsey Rimbault

From: Lizelle Stroh <StrohL@caa.co.za>
Sent: 10 March 2016 14:59
To: Hlengiwe Ntuli
Subject: RE: Two Proposed Tlitseng Solar Photovoltaic Energy Facilities: DSR Comment Period Ending
Attachments: Solar Park footprint corners.xls; Pylon Geographic co ordinates.xls

Your enquiry regarding approval from the SACAA with regard to PV farms refers. There is a SACAA process whereby permission is applied for wrt obstacles which could pose an aviation hazard. More information can be obtained at <http://www.caa.co.za>. Click on information for industry 'Obstacles' on the LHS. Forms, Part 139-27 and submit on the form itself.

- Kindly provide a **.kml (Google Earth) file reflecting the footprint of the proposed development site including the proposed overhead electric power line route that will evacuate the generated power to the national grid.**
- Also indicate the **highest** structure of the project & the Overhead electric power transmission line.
- Note that there may be other wind farms and PV farms in the area. Unique names are preferable.
- *Please always use the proposed PV farm name in the Subject box when corresponding via email with this office and indicate the name & address which should appear on the CAA approval/decline letter.*
- *There is an assessment fee of R725 per application.*
- *For billing purposes: company name VAT nr. and postal details.*
- *Kindly ensure that all the above data is forwarded. Incomplete data causes unnecessary delays.*



Lizell Stroh
Obstacle Specialist
PANS-OPS (Procedures for Air navigation Services – Aircraft Operations)
Air Navigation Services
Tel: +27 11 545 1232 | Fax: +27 011 545 1282 | Mobile: +27 83 461 6660 |
Email: strohl@caa.co.za
www.caa.co.za
Follow us on  

From: Hlengiwe Ntuli [mailto:HlengiweN@sivest.co.za]
Sent: 09 February 2016 02:23 PM
Subject: Two Proposed Tlitseng Solar Photovoltaic Energy Facilities: DSR Comment Period Ending
Importance: High

***** Please note that this email was sent from a NO REPLY email address. Please do not reply to this address as it is an unmonitored email account. *****

Dear Interested and/or Affected Party

ENVIRONMENTAL IMPACT ASSESSMENTS (EIAs) AND ENVIRONMENTAL MANAGEMENT PROGRAMMES (EMPrs) FOR THE PROPOSED DEVELOPMENT OF THE TWO (2) TLISITSENG 75MW SOLAR PHOTOVOLTAIC (PV) ENERGY FACILITIES, NEAR LICHTENBURG, NORTH WEST PROVINCE (DEA REFERENCE NUMBERS TO BE CONFIRMED)

SIVEST sent the Draft Scoping Report for the proposed Tlisitseng Solar PV near Lichtenburg to your Department on 11 January 2016 for comment (refer to the attached email). Please can you advise if comments will be submitted to us for inclusion in the Final Scoping Report.

We would like to inform you that, the comment period for state departments is ending **today** and you are advised to send your comments to us before **Friday 12 February 2016**.

Kind Regards,

Hlengiwe Ntuli
Projects Secretary
SIVEST Environmental & Civils Divisions



SIVEST is a Level 3 BBBEE Contributor

Direct +27 11 798 0690 **Tel** +27 11 798 0600 **fax** +27 11 803 7272
email HlengiweN@sivest.co.za **website** www.sivest.co.za



Consulting Engineers - Project Managers - Environmental Consultants - Town and Regional Planners
Durban - Johannesburg - Pietermaritzburg - Richards Bay - Ladysmith - Cape Town - Harare (Zimbabwe)

Disclaimer

The information contained in this communication from the sender is confidential. It is intended solely for use by the recipient and others authorized to receive it. If you are not the recipient, you are hereby notified that any disclosure, copying, distribution or taking action in relation of the contents of this information is strictly prohibited and may be unlawful.

This email has been scanned for viruses and malware, and automatically archived by Mimecast SA (Pty) Ltd, an innovator in Software as a Service (SaaS) for business. Mimecast Unified Email Management ??? (UEM) offers email continuity, security, archiving and compliance with all current legislation. To find out more, [contact Mimecast](#).



an agency of the
Department of Arts and Culture

T: +27 21 462 4502 | F: +27 21 462 4509 | E: info@sahra.org.za
South African Heritage Resources Agency | 111 Harrington Street | Cape Town
P.O. Box 4637 | Cape Town | 8001
www.sahra.org.za

Enquiries: Nokukhanya Khumalo
Tel: 021 462 4502
Email: nkhumalo@sahra.org.za
CaseID: 9119

Date: Thursday March 10, 2016
Page No: 1

Interim Comment

In terms of Section 38(8) of the National Heritage Resources Act (Act 25 of 1999)

Attention: Sivest - Gauteng
PO BOX 2921
Rivonia
2128

Proposed Construction of the Thlisitseng 1 and Thlisitsenf 2 75MW Solar Photovoltaic (PV) Energy Facilities near Lichtenburg, North West Province

SiVEST Environmental division commissioned PGS Heritage to conduct a Heritage Scoping Report as part of an Environmental Impact Assessment conducted for BioTherm Energy (Pty) Ltd for the proposed development of the Thlisitseng Projects. *Fourie, 2014. Biotherm Energy (Pty) Ltd. Two 75MW Solar Photovoltaic (PV) Energy Facilities - Thlisitseng Projects.*

The proposed development will take place on Portion 25 of the Farm Houthaalboomen No 31. The farm is located approximately 6km north of the town of Lichtenburg, in the Ngaka Modiri Molema District of the North West Province. The application site covers approximately 1000ha, with the development footprint being substantially smaller and directed by the findings and recommendations given in the scoping phase of the EIA.

The proposed Thlisitseng Solar development consists of two 75MW solar PV facilities. These will be named Thlisitseng 1 and 2. In addition to the PV solar development, 132kV power lines will be constructed to connect them with the Thlisitseng substation.

The development footprint falls in an area that is palaeontologically very sensitive. The Monte Christo formation (Malmani Subgroup of the Transvaal Sequence) is highly significant as stromatolites and constituent breccia containing fossiliferous materials which may contain hominid fossils may occur. The author suggests a full Palaeontological Impact Assessment (PIA) to be completed.

Archival research conducted on the area indicates that there is a chance of finding Heritage resources, although analysis of aerial photographs did not immediately indicate any within the proposed area (Fourie, 2014). One farmstead was located within the plan and will need to be assessed along with those in close proximity which may be impacted by the development.

Interim Comment

Our Ref: 9119



an agency of the
Department of Arts and Culture

T: +27 21 462 4502 | F: +27 21 462 4509 | E: info@sahra.org.za
South African Heritage Resources Agency | 111 Harrington Street | Cape Town
P.O. Box 4637 | Cape Town | 8001
www.sahra.org.za

Enquiries: Nokukhanya Khumalo

Tel: 021 462 4502

Email: nkhumalo@sahra.org.za

CaseID: 9119

Date: Thursday March 10, 2016

Page No: 2

SAHRA accepts the Heritage Scoping Report and its recommendations and requires the following studies:

- - A full PIA is conducted to assess the development area as it is situated in a region of very high palaeontological significance.
- - A field survey is required during the EIA phase of the project. Should any finds be made during the field survey, they must be assessed according to the methodology stipulated in Appendix C of the Heritage Scoping Report (Fourie, 2014), and a HIA be submitted for comment.

SAHRA requires the location of the project to be submitted either through SAHRIS or as a KML file.

Final comments will be issued when the above has been completed. Please submit the Final Scoping Report and/or Environmental Impact Assessment upon completion.

Should you have any further queries, please contact the designated official using the case number quoted above in the case header.

Yours faithfully

Nokukhanya Khumalo
Heritage Officer
South African Heritage Resources Agency

ADMIN:

Direct URL to case: <http://www.sahra.org.za/node/356388>

Our Ref: 9119



an agency of the
Department of Arts and Culture

T: +27 21 462 4502 | F: +27 21 462 4509 | E: info@sahra.org.za
South African Heritage Resources Agency | 111 Harrington Street | Cape Town
P.O. Box 4637 | Cape Town | 8001
www.sahra.org.za

Enquiries: Nokukhanya Khumalo
Tel: 021 462 4502
Email: nkhumalo@sahra.org.za
CaseID: 9119

Date: Thursday March 10, 2016
Page No: 3

(DEA, Ref: 14/12/16/3/3/2/890 and 14/12/16/3/3/2/889)

Terms & Conditions:

1. This approval does not exonerate the applicant from obtaining local authority approval or any other necessary approval for proposed work.
2. If any heritage resources, including graves or human remains, are encountered they must be reported to SAHRA immediately.
3. SAHRA reserves the right to request additional information as required.

Network Engineering and Build
Wayleave Management
NORTH EASTERN REGION

Telkom SA SOC Ltd
68 Oak Street
Pretoria
0001

Enquiries : Linda Meyfarth
Tel : (012) 311-8650
Fax : 086 579 2899
E-mail : nerwayleaves@telkom.co.za
Date : 23 May 2016
Expiry Date : 23 November 2016

Our Ref. No: **TK2016/338**
Your Ref: 13033 - Tlisitseng

SIVEST ENVIRONMENTAL

Attention: Andrea Gibb

WAYLEAVE APPLICATION: LICHTENBURG: TLISITSENG – PROPOSED DEVELOPMENT OF TWO SOLAR PHOTOVOLTAIC ENERGY FACILITIES AND BASIC ASSESSMENTS FOR THE ASSOCIATED 132KV POWERLINES NEAR LICHTENBURG - TELKOM AFFECTED

With reference to your above-mentioned application, I hereby inform you that the proposed services are approved in terms of section 22 of the Electronic Communications Act 36 of 2005.

The Planning liaison officer is Annette van Zyl-Swart : 018*469-6517 / 081 536 4727

CALL BEFORE YOU DIG:

Contact: Henk van Wyk : 018*384-0136 / 081 401 1267(Network Field Services) VWykHJ@telkom.co.za
prior to work commencing please.

As exact positions of the cables can only be assumed, due to various reasons, the positioning of the cables as indicated on the attached plan must be regarded as only a guideline. Telkom does not guarantee that the information provided is complete in every respect, and the fact that the information was requested and provided does not limit the responsibility of anyone who is working in the vicinity of Telkom SA SOC Limited's services, to ensure that no damage is caused to Telkom SA SOC Limited's network. The person or organization responsible for any damages to cables or telecommunication equipment during their excavations or construction work will be held responsible for the repair costs. Prior to the commencement of any work, Telkom must be contacted to have the position of the cables identified. Kindly advise this office after completion of the work.

All Telkom SA SOC LTD rights remain reserved.

Yours faithfully,



For: Wayleave Office
Name: Linda Meyfarth
NERWayleaves@telkom.co.za

CLIENT SITE PLAN & LAYOUT: 13033 - TLISITSENG

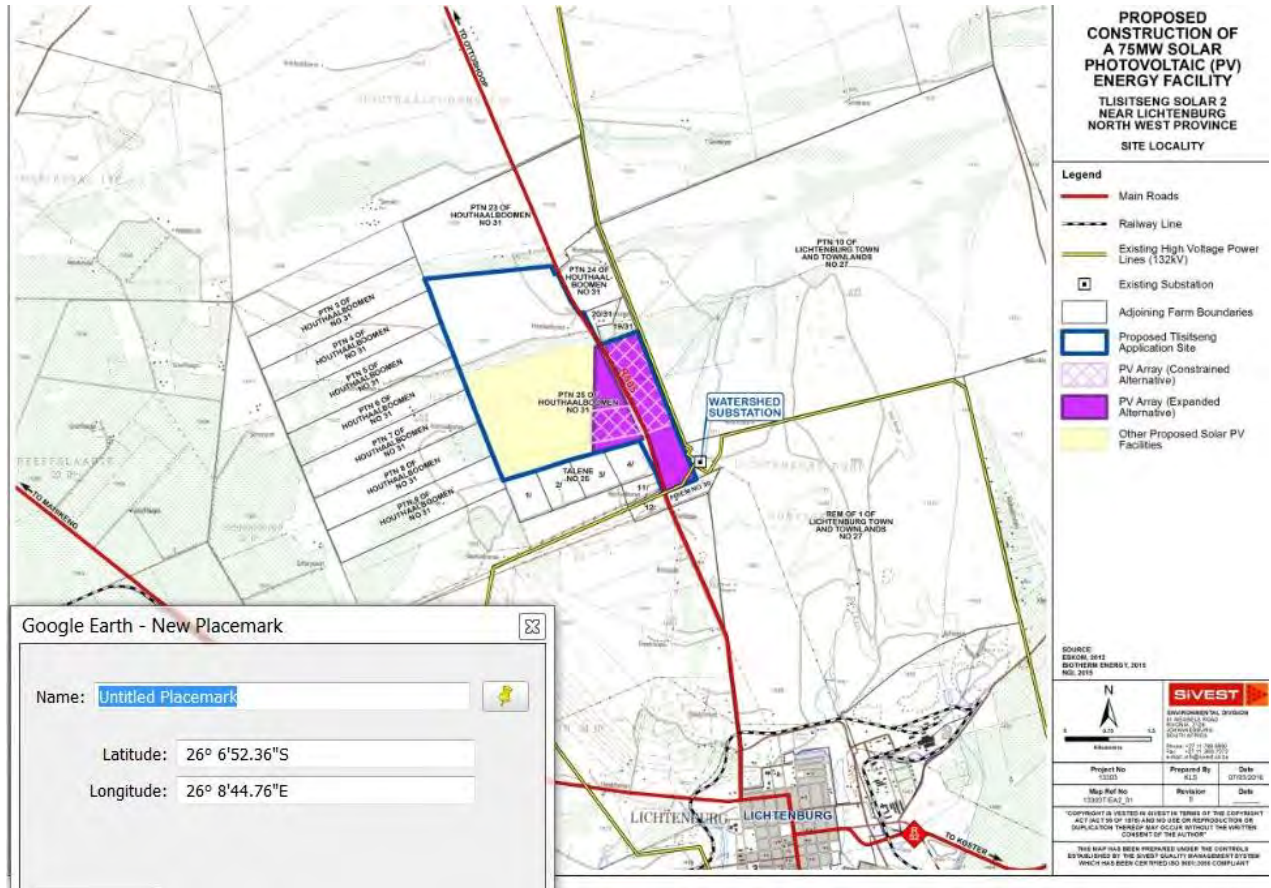

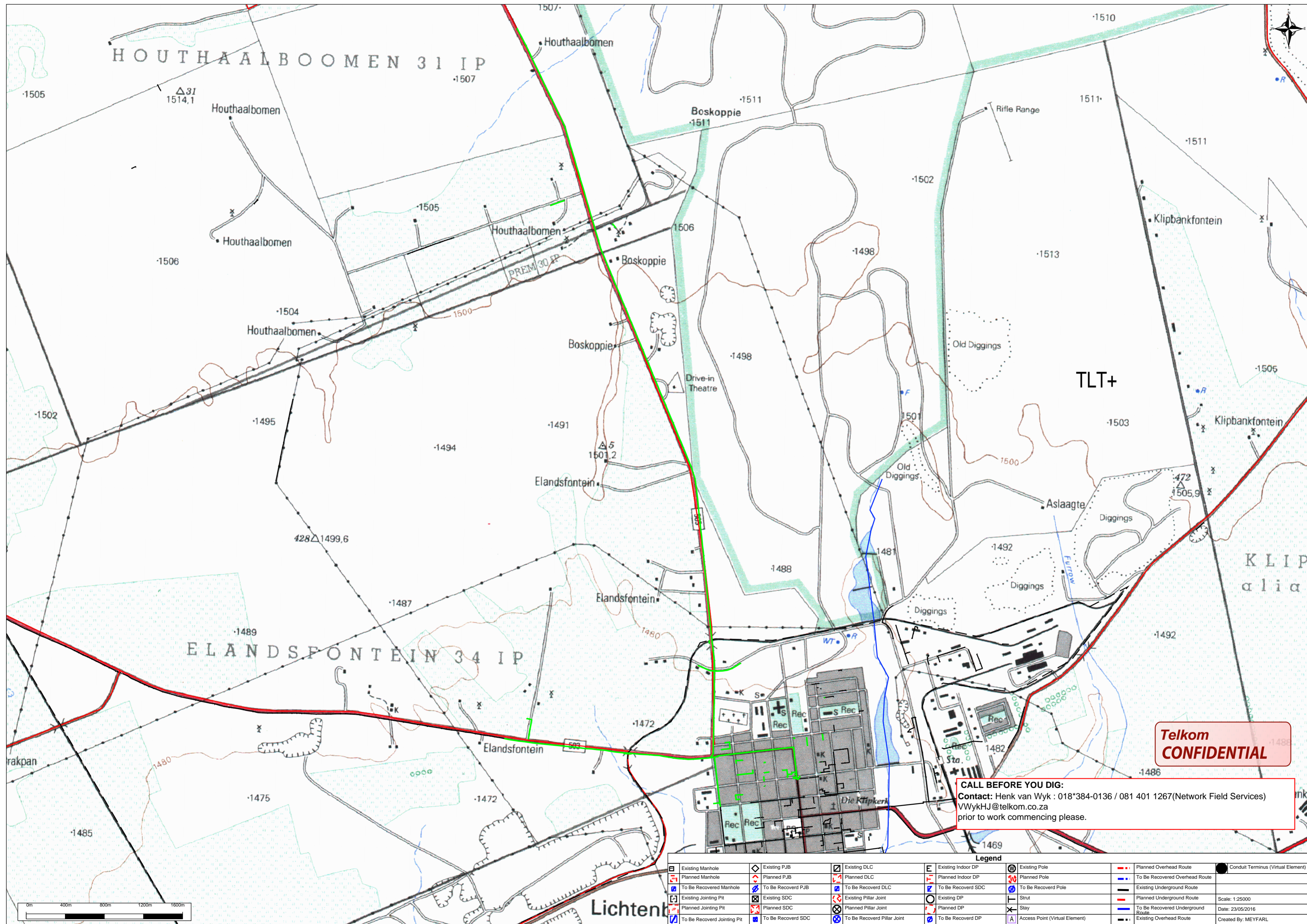

Telkom
CONFIDENTIAL

CALL BEFORE YOU DIG:
 Contact: Henk van Wyk : 018*384-0136 / 081 401 1267(Network Field Services)
 VWykHJ@telkom.co.za
 prior to work commencing please.

Legend										

Scale: 1:25000
 Date: 23/05/2016
 Created By: MEYFARL



agriculture, forestry & fisheries

Department:
Agriculture, Forestry and Fisheries
REPUBLIC OF SOUTH AFRICA

Private Bag X120, Pretoria (Tshwane), 0001
Delpen Building, C/o Annie Botha & Union Street, Riviera, 0084

From: Directorate Land Use and Soil Management
Tel: 012-319-7634 **Fax:** 012-329-5938, **E-mail:** Thokob@nda.agric.za
Enquiries: Help Desk Ref: 2016_01_0117

Sivest Environmental Division
P. O. Box 2921
RIVONIA
2128

Attention: Andrea Gibb

APPLICATION IN TERMS OF THE SUBDIVISION OF AGRICULTURAL LAND ACT, ACT 70 OF 1970: PROPOSED DEVELOPMENT OF THE TWO TLISITSENG 75MW SOLAR PHOTOVOLTAIC ENERGY FACILITIES NEAR LICHTENBURG ON PORTION 25 OF THE FARM HOUTHAALBOOMEN NO.31, NORTH WEST PROVINCE

Your letter 13303 Tlisitseng dated 11 January 2016 refers.

The department herewith informs you that, in terms of Section 4 of Act, 70 of 1970, it does not grant consent for the above-mentioned application. The proposed project will affect the pivots in the area, therefore an alternative area should be identified. This is a unique agricultural land used for agricultural purposes with a clear agricultural character which must be preserved for food production. This will set a precedent that will compromise agricultural production in the area.

It is trusted that you will find the decision in order.

Yours faithfully

DR. M.E. TAU
**DEPUTY DIRECTOR-GENERAL: FORESTRY
AND NATURAL RESOURCES MANAGEMENT**
DELEGATE OF THE MINISTER
DATE: 28/07/2016

Andrea Gibb

From: CherityG <CherityG@daff.gov.za>
Sent: Thursday, September 01, 2016 1:01 PM
To: Andrea Gibb
Subject: Proposed Development of the two Tlisitseng 75MW Solar Photovoltaic energy facilities

Dear applicant

The Department received an application for the proposed development of the two Tlisitseng 75MW Solar Photovoltaic energy facilities. In order to enable us to process your application, kindly forward us a complete EIA so that we can be able to finalise it.

Your prompt response in this regard will be highly appreciated.

Kind regards

Cherity Gombela

Senior Administration Clerk
Land Use and Soil Management
Department of Agriculture, Forestry and Fisheries
Tel: 012 319 7538
Fax: 012 329 5938
Web: www.daff.gov.za
E-mail: CherityG@daff.gov.za



agriculture,
forestry & fisheries

Department:
Agriculture, Forestry and Fisheries
REPUBLIC OF SOUTH AFRICA

Andrea Gibb

From: ThokoB <ThokoB@daff.gov.za>
Sent: Wednesday, September 14, 2016 9:49 AM
To: Irene Bezuidenhout
Cc: Andrea Gibb; Siphелеle Dunga
Subject: RE: Tlisitseng 2x75MW Solar PV
Attachments: gg40247.pdf; Draft PDALB - Version 2.pdf; Written submission template for both Preservation and Development of Agr....docx

Importance: High

Attention Irene

This serves as confirmation of receipt of your request below. I have forwarded the request to a land use advisor Mabule to schedule a meeting with you regarding this matter. Unfortunately the department at this stage is currently busy with workshops for public comments on the new Preservation and Development of Agricultural Land Bill, and Mabule will only be in the office after the 28th of September and can only be in a position to schedule a meeting after that time. If for interest sake you would also like to partake in these workshops, kindly see attached documentation for dates and time for the different provinces.

Your attendance and feedback on the workshops will be highly appreciated.

I hope you find this in order.

Yours in service:

Thoko Buthelezi
Agriland Support Group
Tel: 012 319 7580
Fax: 012 329 5938
E-mail: thokob@daff.gov.za



Andrea Gibb

From: ThokoB <ThokoB@daff.gov.za>
Sent: Thursday, 06 October 2016 8:14 AM
To: Andrea Gibb; Sipehele Dunga (sdunga@biothermenergy.com)
Subject: FW: Tlisitseng 2x75MW Solar PV

Attention Sipehele

Kindly find response below with regards to scheduling a meeting with the department.

I hope you find this in order.

Yours in service:

Thoko Buthelezi
Agriland Support Group
Tel: 012 319 7580
Fax: 012 329 5938
E-mail: thokob@daff.gov.za



From: MabuleR
Sent: Wednesday, October 05, 2016 3:33 PM
To: iBezuidenhout@biothermenergy.com
Cc: ThokoB
Subject: FW: Tlisitseng 2x75MW Solar PV

Good day

Your e-mail request refers.

I Will be available on the 11th October 2016 as follows: (10h15-10h45; 10h50-11H30 and 11H35-12H00)
Please indicate if you will make it and indicate exact time that suit you so that I can book others between these times

Kind Regards

From: ThokoB
Sent: 05 October 2016 12:10 PM
To: MabuleR
Subject: FW: Tlisitseng 2x75MW Solar PV

Colleague

Kindly assist in the request below.

Kr
Thoko

From: Irene Bezuidenhout [<mailto:iBezuidenhout@biothermenergy.com>]
Sent: Wednesday, September 14, 2016 10:03 AM
To: ThokoB

Cc: Andrea Gibb; Siphелеle Dunga
Subject: RE: Tlisitseng 2x75MW Solar PV

Thank you Thoko,

We will await for further details on a meeting. Thanks also for sending the details for the workshops and the draft Bill. We would like to partake in this.

Kind Regards

Irene Bezuidenhout | Environmental Manager
BioTherm Energy (Pty) Ltd
Building 1, Leslie Ave East Design Quarter District, Fourways
P: +27 (0) 11 367 4600 | F: +27 (0) 11 367 4601 | M:+27 (0) 76 822 3484
E: ibezuidenhout@biothermenergy.com



www.biothermenergy.com



Please note that confidential information may be contained in this message. If you are not the addressee indicated in this message you may not copy or deliver this message to anyone. In that event, you should destroy this message and kindly notify the sender by reply e-mail. Any opinions, conclusions and other information contained in this message that do not relate to the official business of BioTherm Energy Group of Companies are neither given nor endorsed by it.

From: ThokoB [<mailto:ThokoB@daff.gov.za>]
Sent: Wednesday, September 14, 2016 9:49 AM
To: Irene Bezuidenhout <ibezuidenhout@biothermenergy.com>
Cc: Andrea Gibb <AndreaG@sivest.co.za>; Siphелеle Dunga <sdunga@biothermenergy.com>
Subject: RE: Tlisitseng 2x75MW Solar PV
Importance: High

Attention Irene

This serves as confirmation of receipt of your request below. I have forwarded the request to a land use advisor Mabule to schedule a meeting with you regarding this matter. Unfortunately the department at this stage is currently busy with workshops for public comments on the new Preservation and Development of Agricultural Land Bill, and Mabule will only be in the office after the 28th of September and can only be in a position to schedule a meeting after that time. If for interest sake you would also like to partake in these workshops, kindly see attached documentation for dates and time for the different provinces.

Your attendance and feedback on the workshops will be highly appreciated.

I hope you find this in order.

Yours in service:

Thoko Buthelezi
Agriland Support Group
Tel: 012 319 7580
Fax: 012 329 5938
E-mail: thokob@daff.gov.za



BEFORE PRINTING THIS E-MAIL
please consider the environment



Wayleave Section

P.O. Box 1772, Vereeniging, 1930

T: +27 16 451 9604 | F: +27 86 478 5977 | C: +27 83 688 1775 | FanieB1@openserve.co.za

October 26, 2016

Sivest SA (Pty) Ltd

P.O. Box 2921

RIVONIA

2128

OPENSERVE REFERENCE: WC457/10/16
APPLICANT REFERENCE: 13303-TLISITSENG
WAYLEAVE EXPIRE DATE: April 26, 2017

WAYLEAVE APPLICATION: ENVIRONMENTAL IMPACT ASSESSMENT FOR THE PROPOSED CONSTRUCTION OF TWO TLISITSENG 75MW SOLAR PHOTOVOLTAIC ENERGY FACILITIES, AND BASIC ASSESSMENTS FOR THE ASSOCIATED 132KV POWER LINES NEAR LICHTENBURG, NORTH WEST PROVINCE

This Company has no objections regarding this proposal. The above proposal is approved in terms of sections 22 of the Electronic Communication Act; act no. 36 of 2005, subject to the stipulations as indicated within this letter being met.

All Telkom SA SOC Limited's plant affected by your proposal has been indicated in **BLUE** on the attached plans, as accurately as possible. Due to various reasons such as the fact that the plans/drawings provided are not to scale, the position of the plant can't be indicated as exact and must be regarded as a guideline only. Our infrastructure depicted only serves to inform the presence of our plant. You are still requested to contact our Network Field Officer, **Mr. Moosa Mothobi at telephone 018 297 2289 or 081 366 1868 or e-mail MoosaM@openserve.co.za** prior to excavation to point out the location of our plant, on site. Any removal or repositioning of existing plant will be done on a repayable basis.

The Requester will duly be held responsible for all costs incurred, should any damages be caused to the Telkom services during construction.

Telkom do not guarantee that the information provided is complete in every respect, and the fact that the information was requested and provided, does not limit the responsibility of anyone who is working in the vicinity of Telkom SA SOC Limited's services, to ensure that no damage is caused to Telkom SA SOC Limited's network.

Approval of the proposed route is valid for **six months** only. If construction has not yet commenced within this time period then the file must be resubmitted for approval. Any changes/deviations from the original planning during or prior to construction must be immediately communicated to this office.

Should Telkom SA SOC Limited infrastructure be damaged while work is undertaken, kindly contact the Toll Free number: 0800 203 951 immediately.

All Telkom SA SOC LTD rights remain reserved.

Best regards,

A handwritten signature in black ink, appearing to read 'B.S. Bezuidenhout', written over a dotted horizontal line.

B.S. Bezuidenhout

Operational Manager

Telkom SA SOC Ltd

NER Access Pointing P.O. Box 1772, Verwoerdweg, 1550, 019 457 0000

Telkom Services: ~~NOT AFFECTED~~ / AFFECTED

Affected plant indicated in blue see legend.

Aerial cable/Pole  Buried cable 

UG pipe/Manhole  Street dish box 

Client ref: 13303 Tikitseng

Telkom ref: WC 457/10/16

Planner name: Ammette Signature: 

**SiVEST
Environmental**

51 Wessel Road, Rivonia
PO Box 2921, Rivonia
2128
Gauteng, South Africa

Phone + 27 11 798 0600
Fax + 27 11 803 7272
Email info@sivest.co.za
www.sivest.co.za



Established 1952

Your reference N/A
Our reference 13303 - Tlisitseng
Date 29 September 2016

Dear Interested and/or Affected Party

ENVIRONMENTAL IMPACT ASSESSMENTS (EIAs) FOR THE PROPOSED CONSTRUCTION OF THE TWO (2) TLISITSENG 75MW SOLAR PHOTOVOLTAIC (PV) ENERGY FACILITIES, AND BASIC ASSESSMENTS (BAs) FOR THE ASSOCIATED 132kV POWER LINES NEAR LICHTENBURG, NORTH WEST PROVINCE (DEA REFERENCE NUMBERS TO BE CONFIRMED)

- INVITATION TO PARTICIPATE IN THE EIA AND BA PROCESSES
- AVAILABILITY OF DRAFT SCOPING REPORTS FOR PUBLIC REVIEW

In terms of the EIA Regulations, 2014 and the National Environmental Management Act, 1998 (Act No. 107 of 1998), SiVEST SA (Pty) Ltd (hereafter referred to as SiVEST) has been appointed as the independent Environmental Assessment Practitioner (EAP) by BioTherm Energy (Pty) Ltd (hereafter referred to as BioTherm) to conduct the EIA processes for the proposed development of the two Tlisitseng 75MW solar photovoltaic (PV) energy facilities and the BA processes for the associated 132kV power lines. The proposed projects are located in the North West Province near Lichtenburg and will be referred to as Tlisitseng 1 Solar, Tlisitseng 2 Solar, Tlisitseng 1 Power Line, and Tlisitseng 2 Power Line.

SiVEST would like to invite you, as a potential Interested and/or Affected Party (I&AP), to become actively involved in the public participation process for this proposed projects. The aim of this process is as follows:

- to ensure that all the relevant environmental impacts are taken into consideration;
- to ensure public input; and
- provide decision-makers with sufficient information to make an informed decision on the proposed activities.

Attached is the Background Information Document (BID) which contains information regarding the proposed project as well as the EIA, BA and public participation process.

The Draft Scoping Reports (DSRs) for the proposed development of the two (2) proposed Tlisitseng 75MW solar PV energy facilities will also be available for public comment and review as from **Thursday 29 September 2016 to Monday 31 October 2016** (end of business day). Should you wish to receive an electronic copy of the DSRs (CD) please forward your request in writing to us. Hard copies of the DSRs can be reviewed at the following public place:

VENUE	STREET ADDRESS	HOURS	CONTACT NO
Lichtenburg Public Library	Nelson Mandela Drive, Lichtenburg	Mondays- Thursdays 09h00 – 17h30 Fridays 09h00 – 17h00 Saturdays 09h00 – 12h00	018 633 3904

The reports are also available on SiVEST's website: <http://www.sivest.co.za/>, then browse to the folder '13303 Tlisitseng PV Energy Development'.

It is important to note that these DSRs are the second versions which will be submitted to the DEA and made available for public comment. On the 18th of January 2016 applications for environmental authorisation (EA) and the

A Division of SiVEST SA (Pty) Ltd

Offices: South Africa Durban, Johannesburg, Ladysmith, Pietermaritzburg, Richards Bay, Cape Town. Africa Harare (Zimbabwe)

Part of the SiVEST Group

SiVEST SA (Pty) Ltd Registration No. 2000/006717/07 via SiVEST

CESA

GREEN BUILDING COUNCIL
MEMBER ORGANISATION 2015



DSRs for the two (2) proposed Tlisitseng 75MW solar PV energy facilities were received by the DEA and reference numbers were allocated to the proposed development (**DEA reference number: 14/12/16/3/3/2/889 and 14/12/16/3/3/2/890**). These original DSRs were made available for public review from the 11th of January 2016 to the 9th of February 2016. The DSRs were thereafter updated and the Final Scoping Reports (FSRs) were submitted to the DEA on the 19th of February 2016. After evaluating the FSRs the DEA issued letters indicating that the documents complied with the minimum requirements of the EIA Regulations, 2014 and that SiVEST could proceed with the EIA processes. The original FSRs were therefore accepted by the DEA. It should however be noted that due to a change in the layout of the two (2) proposed Tlisitseng 75MW solar PV energy facilities, SiVEST was not able to submit the Final Environmental Impact Assessment Reports (FEIARs) within the legislated timeframes. On the 20th of June 2016, SiVEST sent the DEA a letter requesting a sixty (60) day extension in terms of Regulation 3 (7) of the EIA Regulations, 2014, in order to provide the specialists with the opportunity to update their specialist reports in-line with the revised layouts. On the 20th of July 2016, the DEA issued a letter refusing the extension request. For this reason the applications for EA lapsed in accordance with Regulation 45 of the EIA Regulations, 2014 and the departmental files were closed for the project.

In order to reapply for EA for the two (2) proposed Tlisitseng 75MW solar PV energy facilities, BioTherm has appointed SiVEST to recommence with the EIA and BA processes. It should however be noted that all comments received by Interested and Affected Parties (I&APs) during the Public Participation Process (PPP) which was undertaken for the original EIA processes (including those received during meetings) will form part of this EIA process. The public participation process will be re-conducted in accordance with the EIA Regulations, 2014 and all I&APs, Stakeholders and Organs of State will be afforded an extra opportunity to review the DSRs and to provide comments.

By completing and submitting the accompanying registration and comment form, you will be registered as an I&AP on the project database.

We would like to thank you, in advance, for becoming part of the public participation process and are looking forward to receiving your valuable comments relating to the proposed project.

Yours sincerely

A handwritten signature in black ink, appearing to read "Andrea Gibb".

Andrea Gibb
Environmental Practitioner
SiVEST Environmental Division

encl: Background Information Document (BID)
Registration and Comment Form
DSR Executive Summaries



Wayleave Section

P.O. Box 1772, Vereeniging, 1930

T: +27 16 451 9604 | F: +27 86 478 5977 | C: +27 83 688 1775 | FanieB1@openserve.co.za

October 26, 2016

Sivest SA (Pty) Ltd

P.O. Box 2921

RIVONIA

2128

OPENSERVE REFERENCE: WC457/10/16
APPLICANT REFERENCE: 13303-TLISITSENG
WAYLEAVE EXPIRE DATE: April 26, 2017

WAYLEAVE APPLICATION: ENVIRONMENTAL IMPACT ASSESSMENT FOR THE PROPOSED CONSTRUCTION OF TWO TLISITSENG 75MW SOLAR PHOTOVOLTAIC ENERGY FACILITIES, AND BASIC ASSESSMENTS FOR THE ASSOCIATED 132KV POWER LINES NEAR LICHTENBURG, NORTH WEST PROVINCE

This Company has no objections regarding this proposal. The above proposal is approved in terms of sections 22 of the Electronic Communication Act; act no. 36 of 2005, subject to the stipulations as indicated within this letter being met.

All Telkom SA SOC Limited's plant affected by your proposal has been indicated in **BLUE** on the attached plans, as accurately as possible. Due to various reasons such as the fact that the plans/drawings provided are not to scale, the position of the plant can't be indicated as exact and must be regarded as a guideline only. Our infrastructure depicted only serves to inform the presence of our plant. You are still requested to contact our Network Field Officer, **Mr. Moosa Mothobi at telephone 018 297 2289 or 081 366 1868 or e-mail MoosaM@openserve.co.za** prior to excavation to point out the location of our plant, on site. Any removal or repositioning of existing plant will be done on a repayable basis.

The Requester will duly be held responsible for all costs incurred, should any damages be caused to the Telkom services during construction.

Telkom do not guarantee that the information provided is complete in every respect, and the fact that the information was requested and provided, does not limit the responsibility of anyone who is working in the vicinity of Telkom SA SOC Limited's services, to ensure that no damage is caused to Telkom SA SOC Limited's network.

Approval of the proposed route is valid for **six months** only. If construction has not yet commenced within this time period then the file must be resubmitted for approval. Any changes/deviations from the original planning during or prior to construction must be immediately communicated to this office.

Should Telkom SA SOC Limited infrastructure be damaged while work is undertaken, kindly contact the Toll Free number: 0800 203 951 immediately.

All Telkom SA SOC LTD rights remain reserved.

Best regards,

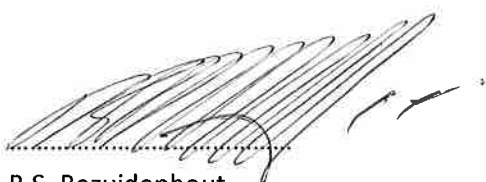
A handwritten signature in black ink, appearing to be 'B.S. Bezuidenhout', written over a dotted horizontal line. The signature is somewhat stylized and includes a small flourish at the end.

B.S. Bezuidenhout
Operational Manager

Telkom SA SOC Ltd

NER Access Pointing P.O. Box 1770, Veranoeng, 9300, 016 481 6900

Telkom Services: **NOT AFFECTED / AFFECTED**

Affected plant indicated in blue see legend.

Aerial cable/Pole  Buried cable 

UG pipe/Manhole  Street dist. box 

Client ref: 13303 Tivitseng

Telkom ref: WC 457/10/16

Planner name: Annette Signature: 



an agency of the
Department of Arts and Culture

T: +27 21 462 4502 | F: +27 21 462 4509 | E: info@sahra.org.za
South African Heritage Resources Agency | 111 Harrington Street | Cape Town
P.O. Box 4637 | Cape Town | 8001
www.sahra.org.za

Enquiries: Nokukhanya Khumalo

Tel: 021 462 4502

Email: nkhumalo@sahra.org.za

CaseID: 9119

Date: Thursday October 27, 2016

Page No: 1

Interim Comment

In terms of Section 38(8) of the National Heritage Resources Act (Act 25 of 1999)

Attention: Sivest - Gauteng

PO BOX 2921

Rivonia

2128

Proposed Construction of the Thlisitseng 1 and Thlisitsenf 2 75MW Solar Photovoltaic (PV) Energy Facilities near Lichtenburg, North West Province

PGS Heritage (Pty) Ltd has submitted an updated Heritage Scoping report to SAHRA via SAHRIS. *Fourie, W. September 2016. Heritage Scoping Report, Two 75MW Solar Photovoltaic (PV) Energy Facilities Thlisitseng Projects.*

The updated report still recommends a field assessment of the proposed Thlisitseng PV 1 and 2 project areas for heritage resources and a full field based Palaeontological Impact Assessment. The assessments are to be conducted by a suitably qualified archaeologist and palaeontologist respectively.

Interim Comment

The following requirements mentioned in SAHRA's comments published 10 March 2016 still stand:

SAHRA accepts the Heritage Scoping Report and its recommendations and requires the following studies:

- A full PIA is conducted to assess the development area as it is situated in a region of very high palaeontological significance.*
- A field survey is required during the EIA phase of the project. Should any finds be made during the field survey, they must be assessed according to the methodology stipulated in Appendix C of the Heritage Scoping Report (Fourie, 2014), and a HIA be submitted for comment.*

Final comments will be issued when the above has been completed. Please submit the Final Scoping Report and/or Environmental Impact Assessment upon completion.

Should you have any further queries, please contact the designated official using the case number quoted above in the case header.

Our Ref: 9119



an agency of the
Department of Arts and Culture

T: +27 21 462 4502 | F: +27 21 462 4509 | E: info@sahra.org.za
South African Heritage Resources Agency | 111 Harrington Street | Cape Town
P.O. Box 4637 | Cape Town | 8001
www.sahra.org.za

Enquiries: Nokukhanya Khumalo
Tel: 021 462 4502
Email: nkhumalo@sahra.org.za
CaseID: 9119

Date: Thursday October 27, 2016
Page No: 2

Yours faithfully

Nokukhanya Khumalo
Heritage Officer
South African Heritage Resources Agency

John Gribble
Manager: Maritime and Underwater Cultural Heritage Unit / Acting Manager: Archaeology, Palaeontology and
Meteorites Unit
South African Heritage Resources Agency

ADMIN:
Direct URL to case: <http://www.sahra.org.za/node/356388>
(DEA, Ref: To be confirmed)

Andrea Gibb

From: Natasha Higgitt <niggitt@sahra.org.za>
Sent: Monday, 14 November 2016 10:01 AM
To: Andrea Gibb
Cc: Nicolene Venter
Subject: Re: 13303 Two Proposed Tlitseng Solar Photovoltaic Energy Facilities – FSRs to DEA

Categories: Tlitseng and Sendawo

Good morning,

Thank you for the update to the case. Please ensure that the Final Scoping Report is uploaded to the SAHRIS Case file (Case ID: 9119). Please ensure that when the draft Environmental Impact Assessment (EIA) is completed that it is uploaded to the case file for review.

Kind Regards,

Natasha Higgitt
Heritage Officer: Archaeology, Palaeontology and Meteorites Unit

South African Heritage Resources Agency
- A nation united through heritage -

T: +27 21 462 4502 | F: +27 21 462 4509
E: niggitt@sahra.org.za | 111 Harrington Street | Cape Town

www.sahra.org.za

Natasha Higgitt
Heritage Officer: Archaeology, Palaeontology and Meteorites Unit

South African Heritage Resources Agency
- A nation united through heritage -

T: +27 21 462 4502 | C: +27 82 507 0378 | F: +27 21 462 4509
E: niggitt@sahra.org.za | 111 Harrington Street | Cape Town | 8001

www.sahra.org.za



From: "sivest_PPP" <sivest_ppp@sivest.co.za>
Cc: "Andrea Gibb" <AndreaG@sivest.co.za>, "Nicolene Venter" <nicolene@imaginativeafrica.co.za>
Sent: Friday, 11 November, 2016 2:54:36 PM
Subject: 13303 Two Proposed Tlitseng Solar Photovoltaic Energy Facilities – FSRs to DEA

***** Please note that this email was sent from a NO REPLY email address. Please do not reply to this address as it is an unmonitored email account.*****

Dear Interested and/or Affected Party,

Tlitseng 1 - DEA Ref. 14/12/16/3/3/2/974

Tisitseng 2 - DEA Ref. 14/12/16/3/3/2/975

Following the public comment and review period of the Draft Scoping Reports (DSRs) from Thursday 29 September 2016 to Monday 31 October 2016 (end of business day) the DSRs were updated, taking into consideration the issues and concerns raised by stakeholders, and the Final Scoping Reports (FSRs) were submitted to the Department of Environmental Affairs (DEA) on Friday 11 November 2016.

The reports are available on SiVEST's website: <http://www.sivest.co.za/>, then browse to the folder '13303 Tlisitseng PV Energy Development'.

We would like to thank you for your active and meaningful contribution to the EIA and Public Participation Process.

Kind Regards

Beste Belangstellende en/of Geaffekteerde Party,

Tisitseng 1 - DO Verw. No. 14/12/16/3/3/2/974

Tisitseng 2 - DO Verw. No. 14/12/16/3/3/2/975

Na aanleiding van die kommentaar deur die openbare oorsigtdperk van die Konsep Omvangsbepalingsverslae van Donderdag 29 September 2016 tot Maandag 31 Oktober 2016 (teen sluitingstyd), was die Konsep Omvangsbepalingsverslae bygewerk en gefinaliseer, met inagneming van die kwessies en kommentaar wat deur belanghebbendes uitgereik was, en die Finale Omvangsbepalingsverslae was op Vrydag 11 November 2016 aan die Departement van Omgewingsake (DO) ingedien vir oorweging.

Die Verslae is beskikbaar op SiVEST se webwerf by: <http://www.sivest.co.za/>, klik op 'Downloads' (regs bo), rol dan ondertoe na '13303 Tlisitseng PV Energy Development'.

Ons dank u vir u aktiewe en betekenisvolle bydrae tot die OIE-proses.

Vriendelike groete,

Kind Regards,

Andrea Gibb (B.Sc. Landscape Architecture; B.Sc.(Hons) Environmental Management)
Environmental Practitioner and Visual Specialist
SiVEST Environmental Division

SiVEST is a Level 3 BBBEE Contributor

Direct +27 11 798 0638 Tel +27 11 798 0600 fax +27 11 803 7272
email andreag@sivest.co.za website www.sivest.co.za

Consulting Engineers - Project Managers - Environmental Consultants - Town and Regional Planners
Durban - Johannesburg - Pietermaritzburg - Richards Bay - Ladysmith - Cape Town - Harare (Zimbabwe)

Disclaimer

The information contained in this communication from the sender is confidential. It is intended solely for use by the recipient and others authorized to receive it. If you are not the recipient, you are hereby notified that any disclosure, copying, distribution or taking action in relation of the contents of this information is strictly prohibited and may be unlawful.

This email has been scanned for viruses and malware, and automatically archived by **Mimecast SA (Pty) Ltd**, an innovator in Software as a Service (SaaS) for business. **Mimecast Unified Email Management ??? (UEM)** offers email continuity, security, archiving and compliance with all current legislation. To find out more, [contact Mimecast](#).

This electronic communication and its content(s) are subject to a disclaimer which can be accessed here: <http://mail.sahra.org.za/disclaimer.html>



Andrea Gibb

From: Jan Oliver (NR) <OliverJ@nra.co.za>
Sent: Wednesday, 08 March 2017 9:15 AM
To: Andrea Gibb
Subject: FW: 13303 Two Proposed Tlisitseng Solar PV Energy Facilities: EIA Newsletter
Attachments: 13303 EIA Newsletter rev1 06 March 2017 AG.PDF

Categories: Tlisitseng and Sendawo

Dear Andrea Gibb

Please email me the Site Layout Maps to see where the facilities are located. I cannot comment given the English and Afrikaans EIA Newsletter alone.

Best regards

Jan Oliver (SANRAL NR)

Tel: 012 426 6242 Fax: Mobile: 083 283 6083 Email: OliverJ@nra.co.za



From: sivist_PPP [mailto:sivist_ppp@sivist.co.za]
Sent: 07 March 2017 03:23 PM
Cc: Andrea Gibb <AndreaG@sivist.co.za>; Veronique Evans <VeroniqueE@sivist.co.za>
Subject: 13303 Two Proposed Tlisitseng Solar PV Energy Facilities: EIA Newsletter

******* Please note that this email was sent from a NO REPLY email address. Please do not reply to this address as it is an unmonitored email account.*******

Dear Stakeholders,

ENVIRONMENTAL IMPACT ASSESSMENT (EIA) FOR THE PROPOSED CONSTRUCTION OF THE TLISITSENG 1 AND TLISITSENG 2 75MW SOLAR PHOTOVOLTAIC (PV) ENERGY FACILITIES NEAR LICHTENBURG, NORTH WEST PROVINCE

- TLISITSENG 1 DEA EIA REF. NO: 14/12/16/3/3/2/974
- TLISITSENG 2 DEA EIA REF. NO: 14/12/16/3/3/2/975

We would like to take this opportunity to inform you that the Department of Environmental Affairs has accepted the Final Scoping Report (FSR) and approved the Plan of Study for the Environmental Impact Phase of the above mentioned projects.

Attached is the English and Afrikaans EIA Newsletter and Site Layout Maps for your information.

Kind Regards,

Andrea Gibb (*B.Sc. Landscape Architecture; B.Sc.(Hons) Environmental Management*)
Environmental Practitioner and Visual Specialist
SiVEST Environmental Division

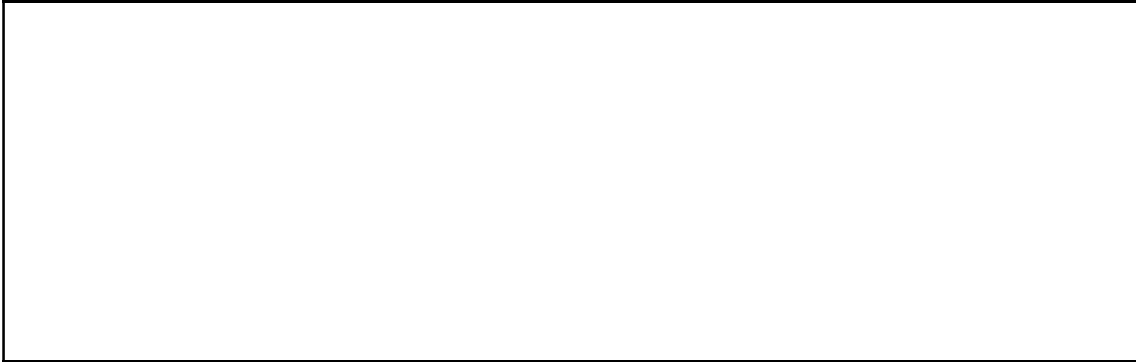

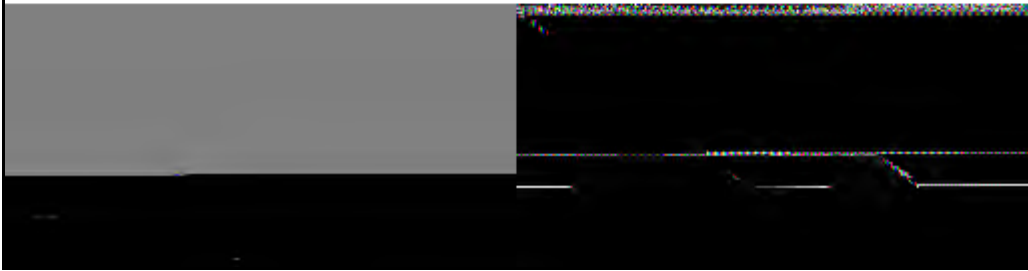

SIVEST is a Level 3 BBBEE Contributor

Direct +27 11 798 0638 **Tel** +27 11 798 0600 **fax** +27 11 803 7272

Consulting Engineers - Project Managers - Environmental Consultants - Town and Regional Planners
Durban - Johannesburg - Pietermaritzburg - Richards Bay - Ladysmith - Cape Town - Harare (Zimbabwe)

Disclaimer

The information contained in this communication from the sender is confidential. It is intended solely for use by the recipient and others authorized to receive it. If you are not the recipient, you are hereby notified that any disclosure, copying, distribution or taking action in relation of the contents of this information is strictly prohibited and may be unlawful.

This email has been scanned for viruses and malware, and automatically archived by **Mimecast SA (Pty) Ltd**, an innovator in Software as a Service (SaaS) for business. **Mimecast Unified Email Management ??? (UEM)** offers email continuity, security, archiving and compliance with all current legislation. To find out more, [contact Mimecast](#).

Disclaimer:

This message contains confidential information and is intended only for the individual named.

If you are not the named addressee you should not disseminate, distribute or copy this e-mail.

Please notify the sender immediately by e-mail if you have received this e-mail by mistake and delete this e-mail from your system. E-mail transmission cannot be guaranteed to be secure or without errors as information could be intercepted, corrupted, lost, destroyed, arrive late or incomplete, or contain viruses.

The sender therefore does not accept liability for any errors or omissions in the contents of this message, which arise as a result of e-mail transmission.

If verification is required please request a hard-copy version. The South African National Roads Agency SOC Ltd, PO Box 415, Pretoria, 0001, South Africa, Tel +27-(0)12 844 8000, www.nra.co.za

This Disclaimer is deemed to form part of the content of this email in terms of Section 11 of the Electronic Communications and Transactions Act, 25 of 2002.

Andrea Gibb

From: Jan Oliver (NR) <OliverJ@nra.co.za>
Sent: Wednesday, 08 March 2017 1:46 PM
To: sivist_PPP
Cc: Veronique Evans; Andrea Gibb; Hlengiwe Ntuli
Subject: RE: Subject: 13303 Two Proposed Tlisitseng Solar PV Energy Facilities: EIA Newsletter

Categories: Tlisitseng and Sendawo

Dear Andrea Gibb

Please email me the Site Layout Maps to see where the facilities are located. I cannot comment given the English and Afrikaans EIA Newsletter alone.

Best regards

Jan Oliver (SANRAL NR)

Tel: 012 426 6242 Fax: Mobile: 083 283 6083 Email: OliverJ@nra.co.za



From: sivist_PPP [mailto:sivist_ppp@sivest.co.za]
Sent: 08 March 2017 01:15 PM
Cc: Veronique Evans <VeroniqueE@sivest.co.za>; Andrea Gibb <AndreaG@sivest.co.za>; Hlengiwe Ntuli <HlengiweN@sivest.co.za>
Subject: Subject: 13303 Two Proposed Tlisitseng Solar PV Energy Facilities: EIA Newsletter
Importance: High

******* Please note that this email was sent from a NO REPLY email address. Please do not reply to this address as it is an unmonitored email account.*******

Dear Stakeholders,

ENVIRONMENTAL IMPACT ASSESSMENT (EIA) FOR THE PROPOSED CONSTRUCTION OF THE TLISITSENG 1 AND TLISITSENG 2 75MW SOLAR PHOTOVOLTAIC (PV) ENERGY FACILITIES NEAR LICHTENBURG, NORTH WEST PROVINCE

- TLISITSENG 1 DEA EIA REF. NO: 14/12/16/3/3/2/974
- TLISITSENG 2 DEA EIA REF. NO: 14/12/16/3/3/2/975

We would like to take this opportunity to inform you that the Department of Environmental Affairs has accepted the Final Scoping Report (FSR) and approved the Plan of Study for the Environmental Impact Phase of the above mentioned projects.

Attached is the English and Afrikaans EIA Newsletter and Site Layout Maps for your information.





Kind Regards,

Andrea Gibb (*B.Sc. Landscape Architecture; B.Sc.(Hons) Environmental Management*)
Environmental Practitioner and Visual Specialist
SiVEST Environmental Division

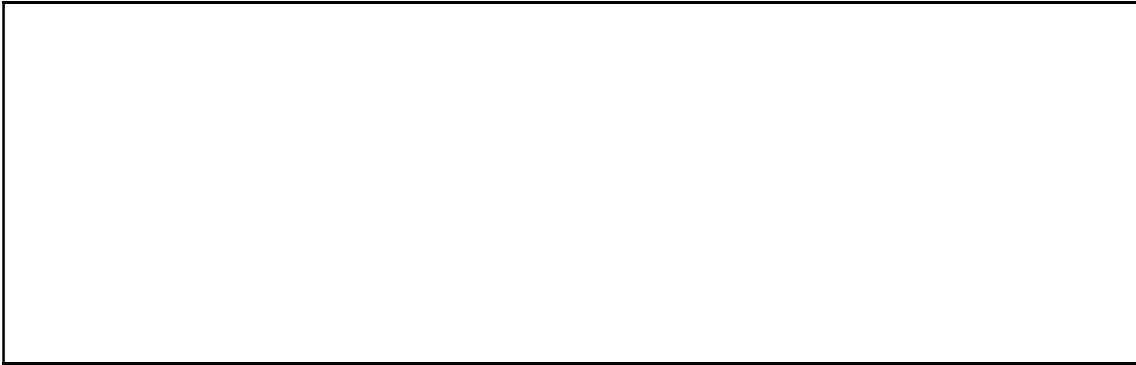

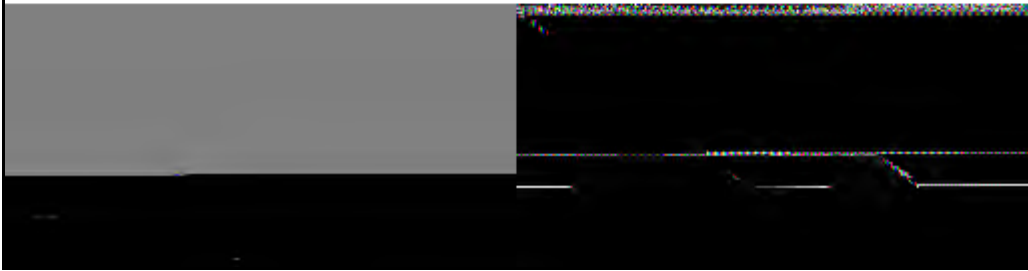

SIVEST is a Level 3 BBBEE Contributor

Direct +27 11 798 0638 **Tel** +27 11 798 0600 **fax** +27 11 803 7272

Consulting Engineers - Project Managers - Environmental Consultants - Town and Regional Planners
Durban - Johannesburg - Pietermaritzburg - Richards Bay - Ladysmith - Cape Town - Harare (Zimbabwe)

Disclaimer

The information contained in this communication from the sender is confidential. It is intended solely for use by the recipient and others authorized to receive it. If you are not the recipient, you are hereby notified that any disclosure, copying, distribution or taking action in relation of the contents of this information is strictly prohibited and may be unlawful.

This email has been scanned for viruses and malware, and automatically archived by **Mimecast SA (Pty) Ltd**, an innovator in Software as a Service (SaaS) for business. **Mimecast Unified Email Management ??? (UEM)** offers email continuity, security, archiving and compliance with all current legislation. To find out more, [contact Mimecast](#).

Disclaimer:

This message contains confidential information and is intended only for the individual named.

If you are not the named addressee you should not disseminate, distribute or copy this e-mail.

Please notify the sender immediately by e-mail if you have received this e-mail by mistake and delete this e-mail from your system. E-mail transmission cannot be guaranteed to be secure or without errors as information could be intercepted, corrupted, lost, destroyed, arrive late or incomplete, or contain viruses.

The sender therefore does not accept liability for any errors or omissions in the contents of this message, which arise as a result of e-mail transmission.

If verification is required please request a hard-copy version. The South African National Roads Agency SOC Ltd, PO Box 415, Pretoria, 0001, South Africa, Tel +27-(0)12 844 8000, www.nra.co.za.

This Disclaimer is deemed to form part of the content of this email in terms of Section 11 of the Electronic Communications and Transactions Act, 25 of 2002.

Andrea Gibb

From: Nokukhanya Khumalo <nkhumalo@sahra.org.za>
Sent: Thursday, 09 March 2017 4:50 PM
To: sivist_PPP
Cc: Andrea Gibb; Hlengiwe Ntuli; Veronique Evans
Subject: Re: 13303 Two Proposed Tlisitseng Solar PV PV Energy Facilities: DEIAr Availability and Comment Period

Categories: Tlisitseng and Sendawo

Good day

Please upload the Draft EIA report to the relevant case on SAHRIS

Kind Regards,

Nokukhanya Khumalo

Nokukhanya Khumalo

Heritage Officer: Archaeology, Palaeontology & Meteorites Unit

South African Heritage Resources Agency
- A nation united through heritage -

T: +27 21 462 4502 | C: | F: +27 21 4624509

E: nkhumalo@sahra.org.za | 111 Harrington Street | Cape Town | 8001

www.sahra.org.za



From: "sivist_PPP" <sivist_ppp@sivist.co.za>
Cc: "Andrea Gibb" <AndreaG@sivist.co.za>, "Hlengiwe Ntuli" <HlengiweN@sivist.co.za>, "Veronique Evans" <VeroniqueE@sivist.co.za>
Sent: Thursday, 9 March, 2017 2:36:49 PM
Subject: 13303 Two Proposed Tlisitseng Solar PV PV Energy Facilities: DEIAr Availability and Comment Period

******* Please note that this email was sent from a NO REPLY email address. Please do not reply to this address as it is an unmonitored email account.*******

Dear Stakeholder

ENVIRONMENTAL IMPACT ASSESSMENT (EIA) FOR THE PROPOSED CONSTRUCTION OF THE TLISITSENG 1 AND TLISITSENG 2 75MW SOLAR PHOTOVOLTAIC (PV) ENERGY FACILITY NEAR LICHTENBURG, NORTH WEST PROVINCE (TLISITSENG 1 DEA EIA REF. NO: 14/12/16/3/3/2/974; TLISITSENG 2 DEA EIA REF. NO: 14/12/16/3/3/2/975)

SiVEST is in the process of undertaking the Environmental Impact Assessment (EIA) for the proposed construction of the Tlisisteng 1 and Tlisitseng 2 Solar PV Energy Facilities near Lichtenburg, North West Province.

We would like to take this opportunity to inform you that, in accordance with the National Environmental Management Act (NEMA), the Draft Environmental Impact Assessment Report (DEIArs) will be made available for public comment and review as from **Thursday 09 March 2017 to Monday 10 April 2017** (end of business day).

An electronic copy (on CD) of the DEIArs as well as the accompanying appendices has been posted to you. The reports are also available on SiVEST's website: <http://www.sivest.co.za>, click on downloads and then browse to the folder '13303 Tlisitseng PV Energy Development'. We kindly request that you submit your comments to Public Participation Office at the below details, on or before **Monday 10 April 2017** (end of business day). SiVEST will forward any comments received after this comment and review period directly to the relevant case officer at the Department of Environmental Affairs (DEA).

Should you have any questions or queries please do not hesitate to contact us at:

Andrea Gibb
PO BOX 2921, Rivonia, 2128
Tel – (011) 798 0600
Fax – (011) 803 7272
Email – andreasivest@sivest.co.za

Kind Regards,

Andrea Gibb (*B.Sc. Landscape Architecture; B.Sc.(Hons) Environmental Management*)
Environmental Practitioner and Visual Specialist
SiVEST Environmental Division



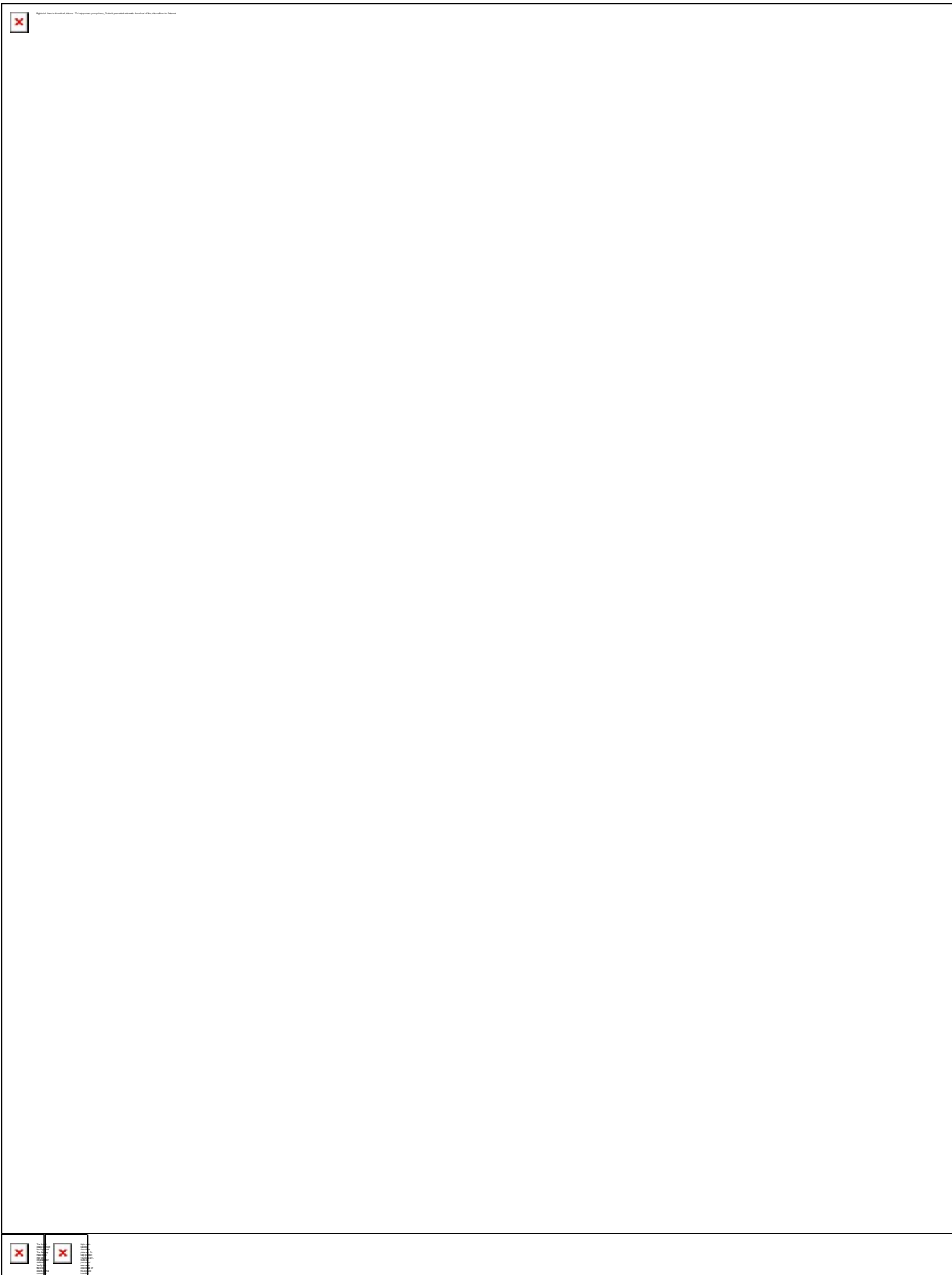

SIVEST is a Level 3 BBBEE Contributor

Direct +27 11 798 0638 **Tel** +27 11 798 0600 **fax** +27 11 803 7272
email andrea@sivest.co.za **website** www.sivest.co.za

Consulting Engineers - Project Managers - Environmental Consultants - Town and Regional Planners
Durban - Johannesburg - Pietermaritzburg - Richards Bay - Ladysmith - Cape Town - Harare (Zimbabwe)

Disclaimer

The information contained in this communication from the sender is confidential. It is intended solely for use by the recipient and others authorized to receive it. If you are not the recipient, you are hereby notified that any disclosure, copying, distribution or taking action in relation of the contents of this information is strictly prohibited and may be unlawful.

This email has been scanned for viruses and malware, and automatically archived by **Mimecast SA (Pty) Ltd**, an innovator in Software as a Service (SaaS) for business. **Mimecast Unified Email Management ??? (UEM)** offers email continuity, security, archiving and compliance with all current legislation. To find out more, [contact Mimecast](#).

This electronic communication and its content(s) are subject to a disclaimer which can be accessed here: <http://mail.sahra.org.za/disclaimer.html>





agriculture, forestry & fisheries

Department:
Agriculture, Forestry and Fisheries
REPUBLIC OF SOUTH AFRICA

Private Bag X120, Pretoria (Tshwane), 0001
Delpen Building, C/o Annie Botha & Union Street, Riviera, 0084

From: Directorate Land Use and Soil Management
Tel: 012-319-7634 Fax: 012-329-5938 E-mail: ThokoB@daff.gov.za
Enquiries: Helpdesk Ref: 2016_05_0164

Sivest
P O Box 2921
RIVONIA
2128

Attention: Andrea Gibb

PROPOSED CONSTRUCTION OF TWO TLISITSENG 75MW SOLAR PHOTOVOLTAIC (PV) ENERGY FACILITIES NEAR LICHTENBURG ON PORTION 25 OF THE FARM HOUTHAALBOOMEN NO. 31, NORTH WEST PROVINCE

Your letter bearing reference 13303-Tlisitseng dated 23 May 2016.

The Department herewith informs you that in terms of Section 4 of Act 70 of 1970, it still does not support the development of two Photovoltaic Solar Energy Facility on a portion measuring approximately 137 hectares and 234 hectares. As was mentioned in the previous letter dated 28 July 2016 the proposed project will affect the cultivation in the area. The Department noted that the layout plans in the draft scoping report shows that the area of the pivots will be affected. The proposal will therefore have a negative influence on the agricultural activities taking place on the property.

This is an agricultural land which can still be used for agricultural purposes with a clear agricultural character which must be preserved for food production. This will consequently set a precedent for future applications in the area that will compromise agricultural production. It is advised that an alternative site be considered for the proposed development.

It is trusted that you will find the above in order.

Yours faithfully

DR M.P. RAMPEDI
DEPUTY DIRECTOR-GENERAL:
FORESTRY AND NATURAL RESOURCES MANAGEMENT
DELEGATE OF THE MINISTER
DATE: 10-03-2017

Andrea Gibb

From: Andrea Gibb
Sent: Wednesday, 08 March 2017 8:52 PM
To: 'Jan Oliver (NR)'
Cc: Veronique Evans; Hlengiwe Ntuli
Subject: RE: Subject: 13303 Two Proposed Tlisitseng Solar PV Energy Facilities: EIA Newsletter
Attachments: A3_13303_T_Project1_SiteLocality_Reduced.jpg; A3_13303_T_Project2_SiteLocality_Reduced.jpg

Hi Jan

Attached are the site locality maps for the two proposed solar PV energy facilities.

Kind Regards

Andrea Gibb (B.Sc. Landscape Architecture; B.Sc.(Hons) Environmental Management)
Environmental Practitioner and Visual Specialist
SiVEST Environmental Division



SiVEST is a Level 3 BBBEE Contributor



Direct +27 11 798 0638 **Tel** +27 11 798 0600 **fax** +27 11 803 7272 **cell** +27 72 587 6525
email andreag@sivest.co.za **website** www.sivest.co.za



Consulting Engineers - Project Managers - Environmental Consultants - Town and Regional Planners
Durban - Johannesburg - Pietermaritzburg - Richards Bay - Ladysmith - Cape Town - Harare (Zimbabwe)

From: Jan Oliver (NR) [mailto:OliverJ@nra.co.za]
Sent: Wednesday, 08 March 2017 1:46 PM
To: sivest_PPP <sivest_ppp@sivest.co.za>
Cc: Veronique Evans <VeroniqueE@sivest.co.za>; Andrea Gibb <AndreaG@sivest.co.za>; Hlengiwe Ntuli <HlengiweN@sivest.co.za>
Subject: RE: Subject: 13303 Two Proposed Tlisitseng Solar PV Energy Facilities: EIA Newsletter

Dear Andrea Gibb

Please email me the Site Layout Maps to see where the facilities are located. I cannot comment given the English and Afrikaans EIA Newsletter alone.

Best regards

Jan Oliver (SANRAL NR)
Tel: 012 426 6242 Fax: Mobile: 083 283 6083 Email: OliverJ@nra.co.za



From: sivist_PPP [mailto:sivist_ppp@sivist.co.za]

Sent: 08 March 2017 01:15 PM

Cc: Veronique Evans <VeroniqueE@sivist.co.za>; Andrea Gibb <AndreaG@sivist.co.za>; Hlengiwe Ntuli <HlengiweN@sivist.co.za>

Subject: Subject: 13303 Two Proposed Tlisitseng Solar PV Energy Facilities: EIA Newsletter

Importance: High

******* Please note that this email was sent from a NO REPLY email address. Please do not reply to this address as it is an unmonitored email account. *******

Dear Stakeholders,

ENVIRONMENTAL IMPACT ASSESSMENT (EIA) FOR THE PROPOSED CONSTRUCTION OF THE TLISITSENG 1 AND TLISITSENG 2 75MW SOLAR PHOTOVOLTAIC (PV) ENERGY FACILITIES NEAR LICHTENBURG, NORTH WEST PROVINCE

- TLISITSENG 1 DEA EIA REF. NO: 14/12/16/3/3/2/974
- TLISITSENG 2 DEA EIA REF. NO: 14/12/16/3/3/2/975

We would like to take this opportunity to inform you that the Department of Environmental Affairs has accepted the Final Scoping Report (FSR) and approved the Plan of Study for the Environmental Impact Phase of the above mentioned projects.

Attached is the English and Afrikaans EIA Newsletter and Site Layout Maps for your information.





Kind Regards,

Andrea Gibb (*B.Sc. Landscape Architecture; B.Sc.(Hons) Environmental Management*)
Environmental Practitioner and Visual Specialist
SiVEST Environmental Division

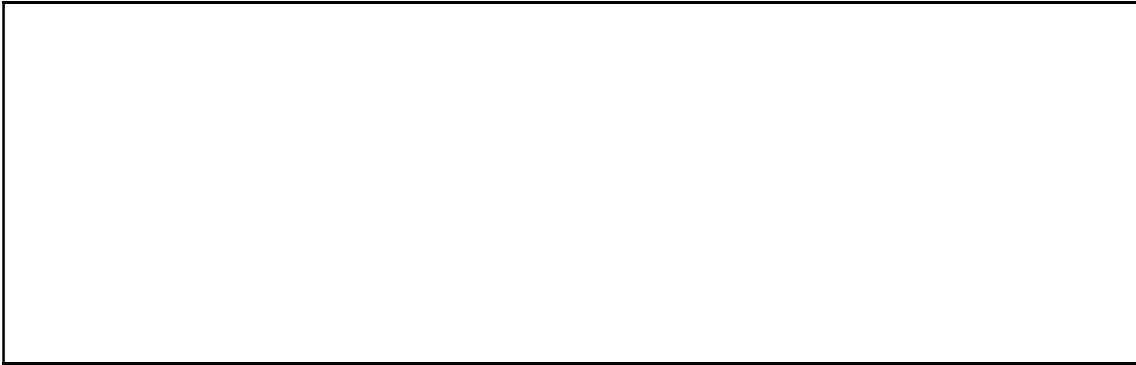

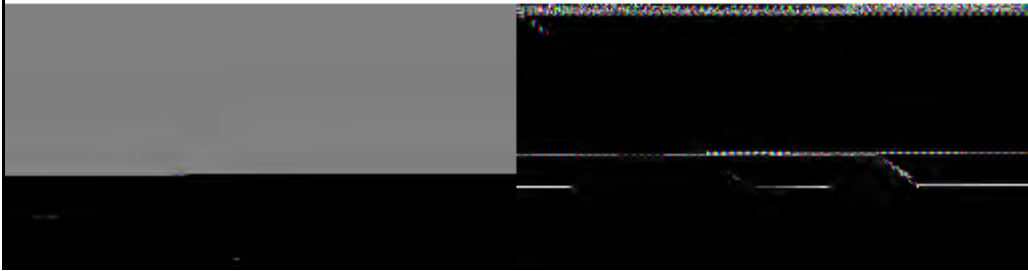

SIVEST is a Level 3 BBBEE Contributor

Direct +27 11 798 0638 **Tel** +27 11 798 0600 **fax** +27 11 803 7272

Consulting Engineers - Project Managers - Environmental Consultants - Town and Regional Planners
Durban - Johannesburg - Pietermaritzburg - Richards Bay - Ladysmith - Cape Town - Harare (Zimbabwe)

Disclaimer

The information contained in this communication from the sender is confidential. It is intended solely for use by the recipient and others authorized to receive it. If you are not the recipient, you are hereby notified that any disclosure, copying, distribution or taking action in relation of the contents of this information is strictly prohibited and may be unlawful.

This email has been scanned for viruses and malware, and automatically archived by **Mimecast SA (Pty) Ltd**, an innovator in Software as a Service (SaaS) for business. **Mimecast Unified Email Management ??? (UEM)** offers email continuity, security, archiving and compliance with all current legislation. To find out more, [contact Mimecast](#).

Disclaimer:

This message contains confidential information and is intended only for the individual named.
If you are not the named addressee you should not disseminate, distribute or copy this e-mail.

Please notify the sender immediately by e-mail if you have received this e-mail by mistake and delete this e-mail from your system. E-mail transmission cannot be guaranteed to be secure or without errors as information could be intercepted, corrupted, lost, destroyed, arrive late or incomplete, or contain viruses.

The sender therefore does not accept liability for any errors or omissions in the contents of this message, which arise as a result of e-mail transmission. If verification is required please request a hard-copy version. The South African National Roads Agency SOC Ltd, PO Box 415, Pretoria, 0001, South Africa, Tel +27-(0)12 844 8000, www.nra.co.za.

This Disclaimer is deemed to form part of the content of this email in terms of Section 11 of the Electronic Communications and Transactions Act, 25 of 2002.

Andrea Gibb

From: Andrea Gibb
Sent: Wednesday, 08 March 2017 9:59 AM
To: 'Jan Oliver (NR)'
Subject: RE: 13303 Two Proposed Tlisitseng Solar PV Energy Facilities: EIA Newsletter

Hi Jan

Apologies, we omitted to attach the maps. We will be resending everything this morning.

Kind Regards

Andrea Gibb (B.Sc. Landscape Architecture; B.Sc.(Hons) Environmental Management)

Environmental Practitioner and Visual Specialist

SiVEST Environmental Division



SiVEST is a Level 3 BBBEE Contributor

Direct +27 11 798 0638 **Tel** +27 11 798 0600 **fax** +27 11 803 7272 **cell** +27 72 587 6525
email andrea@sivest.co.za **website** www.sivest.co.za



Consulting Engineers - Project Managers - Environmental Consultants - Town and Regional Planners
Durban - Johannesburg - Pietermaritzburg - Richards Bay - Ladysmith - Cape Town - Harare (Zimbabwe)

From: Jan Oliver (NR) [mailto:OliverJ@nra.co.za]
Sent: Wednesday, 08 March 2017 9:15 AM
To: Andrea Gibb <AndreaG@sivest.co.za>
Subject: FW: 13303 Two Proposed Tlisitseng Solar PV Energy Facilities: EIA Newsletter

Dear Andrea Gibb

Please email me the Site Layout Maps to see where the facilities are located. I cannot comment given the English and Afrikaans EIA Newsletter alone.

Best regards

Jan Oliver (SANRAL NR)

Tel: 012 426 6242 Fax: Mobile: 083 283 6083 Email: OliverJ@nra.co.za



From: sivist_PPP [mailto:sivist_ppp@sivest.co.za]
Sent: 07 March 2017 03:23 PM
Cc: Andrea Gibb <AndreaG@sivest.co.za>; Veronique Evans <VeroniqueE@sivest.co.za>
Subject: 13303 Two Proposed Tlisitseng Solar PV Energy Facilities: EIA Newsletter

***** Please note that this email was sent from a NO REPLY email address. Please do not reply to this address as it is an unmonitored email account.*****

Dear Stakeholders,

ENVIRONMENTAL IMPACT ASSESSMENT (EIA) FOR THE PROPOSED CONSTRUCTION OF THE TLISITSENG 1 AND TLISITSENG 2 75MW SOLAR PHOTOVOLTAIC (PV) ENERGY FACILITIES NEAR LICHTENBURG, NORTH WEST PROVINCE

- TLISITSENG 1 DEA EIA REF. NO: 14/12/16/3/3/2/974
- TLISITSENG 2 DEA EIA REF. NO: 14/12/16/3/3/2/975

We would like to take this opportunity to inform you that the Department of Environmental Affairs has accepted the Final Scoping Report (FSR) and approved the Plan of Study for the Environmental Impact Phase of the above mentioned projects.

Attached is the English and Afrikaans EIA Newsletter and Site Layout Maps for your information.

Kind Regards,

Andrea Gibb (*B.Sc. Landscape Architecture; B.Sc.(Hons) Environmental Management*)
Environmental Practitioner and Visual Specialist
SiVEST Environmental Division





SIVEST is a Level 3 BBBEE Contributor

Direct +27 11 798 0638 **Tel** +27 11 798 0600 **fax** +27 11 803 7272

Consulting Engineers - Project Managers - Environmental Consultants - Town and Regional Planners
Durban - Johannesburg - Pietermaritzburg - Richards Bay - Ladysmith - Cape Town - Harare (Zimbabwe)

Disclaimer

The information contained in this communication from the sender is confidential. It is intended solely for use by the recipient and others authorized to receive it. If you are not the recipient, you are hereby notified that any disclosure, copying, distribution or taking action in relation of the contents of this information is strictly prohibited and may be unlawful.

This email has been scanned for viruses and malware, and automatically archived by **Mimecast SA (Pty) Ltd**, an innovator in Software as a Service (SaaS) for business. **Mimecast Unified Email Management ??? (UEM)** offers email continuity, security, archiving and compliance with all current legislation. To find out more, [contact Mimecast](#).

Disclaimer:

This message contains confidential information and is intended only for the individual named.

If you are not the named addressee you should not disseminate, distribute or copy this e-mail.

Please notify the sender immediately by e-mail if you have received this e-mail by mistake and delete this e-mail from your system. E-mail transmission cannot be guaranteed to be secure or without errors as information could be intercepted, corrupted, lost, destroyed, arrive late or incomplete, or contain viruses.

The sender therefore does not accept liability for any errors or omissions in the contents of this message, which arise as a result of e-mail transmission.

If verification is required please request a hard-copy version. The South African National Roads Agency SOC Ltd, PO Box 415, Pretoria, 0001, South Africa, Tel +27-(0)12 844 8000, www.nra.co.za

This Disclaimer is deemed to form part of the content of this email in terms of Section 11 of the Electronic Communications and Transactions Act, 25 of 2002.

Andrea Gibb

From: Sipehelele Dunga <sdunga@biothermenergy.com>
Sent: Thursday, October 06, 2016 8:26 AM
To: ThokoB; Andrea Gibb
Subject: RE: Tlisitseng 2x75MW Solar PV

Hi Thoko

Thank you for the mail. I have sent the meeting request already. Please advise if you want to be part of the meeting as well so I can send you an invite.

Kind Regards

From: ThokoB [mailto:ThokoB@daff.gov.za]
Sent: 06 October 2016 08:14 AM
To: Andrea Gibb (AndreaG@sivest.co.za) <AndreaG@sivest.co.za>; Sipehelele Dunga <sdunga@biothermenergy.com>
Subject: FW: Tlisitseng 2x75MW Solar PV

Attention Sipehelele

Kindly find response below with regards to scheduling a meeting with the department.

I hope you find this in order.

Yours in service:

Thoko Buthelezi
Agriland Support Group
Tel: 012 319 7580
Fax: 012 329 5938
E-mail: thokob@daff.gov.za



BEFORE PRINTING THIS E-MAIL
please consider the environment

From: MabuleR
Sent: Wednesday, October 05, 2016 3:33 PM
To: iBezuidenhout@biothermenergy.com
Cc: ThokoB
Subject: FW: Tlisitseng 2x75MW Solar PV

Good day

Your e-mail request refers.

I Will be available on the 11th October 2016 as follows: (10h15-10h45; 10h50-11H30 and 11H35-12H00)
Please indicate if you will make it and indicate exact time that suit you so that I can book others between these times

Kind Regards

From: ThokoB
Sent: 05 October 2016 12:10 PM
To: MabuleR
Subject: FW: Tlisitseng 2x75MW Solar PV

Colleague

Kindly assist in the request below.

Kr
Thoko

From: Irene Bezuidenhout [<mailto:iBezuidenhout@biothermenergy.com>]
Sent: Wednesday, September 14, 2016 10:03 AM
To: ThokoB
Cc: Andrea Gibb; Sipehelele Dunga
Subject: RE: Tlisitseng 2x75MW Solar PV

Thank you Thoko,

We will await for further details on a meeting. Thanks also for sending the details for the workshops and the draft Bill. We would like to partake in this.

Kind Regards

Irene Bezuidenhout | Environmental Manager
BioTherm Energy (Pty) Ltd
Building 1, Leslie Ave East Design Quarter District, Fourways
P: +27 (0) 11 367 4600 | F: +27 (0) 11 367 4601 | M:+27 (0) 76 822 3484
E: ibeazuidenhout@biothermenergy.com



www.biothermenergy.com



Please note that confidential information may be contained in this message. If you are not the addressee indicated in this message you may not copy or deliver this message to anyone. In that event, you should destroy this message and kindly notify the sender by reply e-mail. Any opinions, conclusions and other information contained in this message that do not relate to the official business of BioTherm Energy Group of Companies are neither given nor endorsed by it.

From: ThokoB [<mailto:ThokoB@daff.gov.za>]
Sent: Wednesday, September 14, 2016 9:49 AM
To: Irene Bezuidenhout <iBezuidenhout@biothermenergy.com>
Cc: Andrea Gibb <AndreaG@sivest.co.za>; Sipehelele Dunga <sdunga@biothermenergy.com>
Subject: RE: Tlisitseng 2x75MW Solar PV
Importance: High

Attention Irene

This serves as confirmation of receipt of your request below. I have forwarded the request to a land use advisor Mabule to schedule a meeting with you regarding this matter. Unfortunately the department at this stage is currently busy with workshops for public comments on the new Preservation and Development of Agricultural Land Bill, and Mabule will only be in the office after the 28th of September and can only be in a position to schedule a meeting after that time. If for interest sake you would also like to partake in these workshops, kindly see attached documentation for dates and time for the different provinces.

Your attendance and feedback on the workshops will be highly appreciated.

I hope you find this in order.

Yours in service:

Thoko Buthelezi

Agriland Support Group

Tel: 012 319 7580

Fax: 012 329 5938

E-mail: thokob@daff.gov.za



BEFORE PRINTING THIS E-MAIL
please consider the environment

Andrea Gibb

From: Irene Bezuidenhout <iBezuidenhout@biothermenergy.com>
Sent: Wednesday, September 14, 2016 10:03 AM
To: ThokoB
Cc: Andrea Gibb; Sipehelele Dunga
Subject: RE: Tlisitseng 2x75MW Solar PV

Thank you Thoko,

We will await for further details on a meeting. Thanks also for sending the details for the workshops and the draft Bill. We would like to partake in this.

Kind Regards

Irene Bezuidenhout | Environmental Manager
BioTherm Energy (Pty) Ltd
Building 1, Leslie Ave East Design Quarter District, Fourways
P: +27 (0) 11 367 4600 | F: +27 (0) 11 367 4601 | M:+27 (0) 76 822 3484
E: ibeuzidenhout@biothermenergy.com



www.biothermenergy.com



Please note that confidential information may be contained in this message. If you are not the addressee indicated in this message you may not copy or deliver this message to anyone. In that event, you should destroy this message and kindly notify the sender by reply e-mail. Any opinions, conclusions and other information contained in this message that do not relate to the official business of BioTherm Energy Group of Companies are neither given nor endorsed by it.

From: ThokoB [mailto:ThokoB@daff.gov.za]
Sent: Wednesday, September 14, 2016 9:49 AM
To: Irene Bezuidenhout <iBezuidenhout@biothermenergy.com>
Cc: Andrea Gibb <AndreaG@sivest.co.za>; Sipehelele Dunga <sdunga@biothermenergy.com>
Subject: RE: Tlisitseng 2x75MW Solar PV
Importance: High

Attention Irene

This serves as confirmation of receipt of your request below. I have forwarded the request to a land use advisor Mabule to schedule a meeting with you regarding this matter. Unfortunately the department at this stage is currently busy with workshops for public comments on the new Preservation and Development of Agricultural Land Bill, and Mabule will only be in the office after the 28th of September and can only be in a position to schedule a meeting after that time. If for interest sake you would also like to partake in these workshops, kindly see attached documentation for dates and time for the different provinces.

Your attendance and feedback on the workshops will be highly appreciated.

I hope you find this in order.

Yours in service:

Thoko Buthelezi
Agriland Support Group
Tel: 012 319 7580
Fax: 012 329 5938
E-mail: thokob@daff.gov.za



BEFORE PRINTING THIS E-MAIL
please consider the environment

Andrea Gibb

From: Irene Bezuidenhout <iBezuidenhout@biothermenergy.com>
Sent: Monday, September 12, 2016 9:44 AM
To: thokob@nda.agric.za
Cc: Andrea Gibb; Sipehelele Dunga
Subject: FW: Tlisitseng 2x75MW Solar PV
Attachments: Daff Response letter.pdf

Good day Thoko,

The below and attached refer. My colleague Sipehelele sent this to you 2 September 2016, I noticed that the e-mail address was incorrect. Please will you consider the attached letter and provide feedback at your earliest convenience.

Please contact me should you wish to discuss this further.

Kind Regards

Irene Bezuidenhout | Environmental Manager
BioTherm Energy (Pty) Ltd
Building 1, Leslie Ave East Design Quarter District, Fourways
P: +27 (0) 11 367 4600 | F: +27 (0) 11 367 4601 | M:+27 (0) 76 822 3484
E: ibezauidenhout@biothermenergy.com



www.biothermenergy.com



Please note that confidential information may be contained in this message. If you are not the addressee indicated in this message you may not copy or deliver this message to anyone. In that event, you should destroy this message and kindly notify the sender by reply e-mail. Any opinions, conclusions and other information contained in this message that do not relate to the official business of BioTherm Energy Group of Companies are neither given nor endorsed by it.

From: Sipehelele Dunga
Sent: Friday, September 2, 2016 3:52 PM
To: thokob@nda.agri.za
Cc: Andrea Gibb <AndreaG@sivest.co.za>; Irene Bezuidenhout <iBezuidenhout@biothermenergy.com>
Subject: Tlisitseng 2x75MW Solar PV

Dear Thoko

Attached for your records is a response to the letter that was sent by the Department on the 28th of July 2016 to SiVest Environmental with regards to the Proposed 2x75MW Tlisitseng Solar PV Energy Facilities near Lichtenburg, North West Province.

Kindly note that a hard copy has been sent via post to your offices addressed to the Deputy Director General.

Warm Regards

Sipehelele Dunga | Analyst

BioTherm Energy (Pty) Ltd

Building 1, Leslie Ave East, Design Quarter District, Fourways

P: +27 (0) 11 367 4614 | F: +27 (0) 11 367 4601 | M: 062 135 4336

E: sdunga@biothermenergy.com



www.biothermenergy.com



Please note that confidential information may be contained in this message. If you are not the addressee indicated in this message you may not copy or deliver this message to anyone. In that event, you should destroy this message and kindly notify the sender by reply e-mail. Any opinions, conclusions and other information contained in this message that do not relate to the official business of BioTherm Energy Group of Companies are neither given nor endorsed by it.

Andrea Gibb

From: Irene Bezuidenhout <iBezuidenhout@biothermenergy.com>
Sent: Wednesday, September 07, 2016 2:57 PM
To: Siphelele Dunga; thokob@nda.agri.za
Cc: Andrea Gibb
Subject: RE: Tlisitseng 2x75MW Solar PV

Good day Thoko,

Please can you confirm if whether you received the letter that was sent to you by Siphelele Dunga on Friday 2 September.

We would like to set up a meeting should you wish to discuss it in more detail.

Kind Regards

Irene Bezuidenhout | Environmental Manager
BioTherm Energy (Pty) Ltd
Building 1, Leslie Ave East Design Quarter District, Fourways
P: +27 (0) 11 367 4600 | F: +27 (0) 86 428 4746 | M:+27 (0) 76 822 3484
E: ibeazuidenhout@biothermenergy.com



www.biothermenergy.com



Please note that confidential information may be contained in this message. If you are not the addressee indicated in this message you may not copy or deliver this message to anyone. In that event, you should destroy this message and kindly notify the sender by reply e-mail. Any opinions, conclusions and other information contained in this message that do not relate to the official business of BioTherm Energy Group of Companies are neither given nor endorsed by it.

From: Siphelele Dunga
Sent: Friday, September 2, 2016 3:52 PM
To: thokob@nda.agri.za
Cc: Andrea Gibb <AndreaG@sivest.co.za>; Irene Bezuidenhout <iBezuidenhout@biothermenergy.com>
Subject: Tlisitseng 2x75MW Solar PV

Dear Thoko

Attached for your records is a response to the letter that was sent by the Department on the 28th of July 2016 to SiVest Environmental with regards to the Proposed 2x75MW Tlisitseng Solar PV Energy Facilities near Lichtenburg, North West Province.

Kindly note that a hard copy has been sent via post to your offices addressed to the Deputy Director General.

Warm Regards

Siphelele Dunga | Analyst
BioTherm Energy (Pty) Ltd
Building 1, Leslie Ave East, Design Quarter District, Fourways

P: +27 (0) 11 367 4614 | F: +27 (0) 11 367 4601 | M: 062 135 4336
E: sdunga@biothermenergy.com



www.biothermenergy.com



Please note that confidential information may be contained in this message. If you are not the addressee indicated in this message you may not copy or deliver this message to anyone. In that event, you should destroy this message and kindly notify the sender by reply e-mail. Any opinions, conclusions and other information contained in this message that do not relate to the official business of BioTherm Energy Group of Companies are neither given nor endorsed by it.

Andrea Gibb

From: Andrea Gibb
Sent: Friday, September 02, 2016 6:38 AM
To: 'CherityG'
Subject: RE: Proposed Development of the two Tlisitseng 75MW Solar Photovoltaic energy facilities

Dear Cherity

Please note the applications for environmental authorisation for the Tlisitseng Solar PV Facilities have lapsed as the legislated timeframes could not be adhered to due to a layout change which affected both projects.

As such, applications for environmental authorisation will be resubmitted to the DEA and the project will restart later this month.

You will be notified as the project progresses.

Kind Regards

Andrea Gibb (B.Sc. Landscape Architecture; B.Sc.(Hons) Environmental Management)
Environmental Practitioner and Visual Specialist
SiVEST Environmental Division



SiVEST is a Level 3 BBBEE Contributor

Direct +27 11 798 0638 **Tel** +27 11 798 0600 **fax** +27 11 803 7272 **cell** +27 72 587 6525
email andrea@sivest.co.za **website** www.sivest.co.za



Consulting Engineers - Project Managers - Environmental Consultants - Town and Regional Planners
Durban - Johannesburg - Pietermaritzburg - Richards Bay - Ladysmith - Cape Town - Harare (Zimbabwe)

From: CherityG [mailto:CherityG@daff.gov.za]
Sent: Thursday, September 01, 2016 1:01 PM
To: Andrea Gibb <AndreaG@sivest.co.za>
Subject: Proposed Development of the two Tlisitseng 75MW Solar Photovoltaic energy facilities

Dear applicant

The Department received an application for the proposed development of the two Tlisitseng 75MW Solar Photovoltaic energy facilities. In order to enable us to process your application, kindly forward us a complete EIA so that we can be able to finalise it.

Your prompt response in this regard will be highly appreciated.

Kind regards

Cherity Gombela

Senior Administration Clerk
Land Use and Soil Management
Department of Agriculture, Forestry and Fisheries

Tel: 012 319 7538
Fax: 012 329 5938
Web: www.daff.gov.za
E-mail: CherityG@daff.gov.za



agriculture,
forestry & fisheries

Department:
Agriculture, Forestry and Fisheries
REPUBLIC OF SOUTH AFRICA



BioTherm Energy (Pty) Ltd
Building 1, Ground Floor
Leslie Ave East
The Design Quarter District, Four ways
Gauteng, South Africa
P O Box 69408, Bryans ton, 2021
Tel: +27 11 367 4600
Fax: +27 11 367 4601
www.biothermenergy.com
Registration Number: 2003/020443/07
VAT Registration Number: 4620220261

31 August 2016

Dr. M.E.TAU
Deputy Director General
Directorate: Land Use and Soil Management
Delpen Building
C/o Annie Botha & Union Street
Riveria
0084

Dear Sir/ Madam

PROPOSED DEVELOPMENT OF THE TWO TLISITSENG 75MW SOLAR PHOTOVOLTAIC ENERGY FACILITIES NEAR LICHTENBURG ON PORTION 25 OF THE FARM HOUTHAAALBOOMEN NO 31, NORTH WEST PROVINCE

Your letter addressed to Andrea Gibb dated 28 July 2016 and attached hereto refers.

BioTherm Energy (Pty) Ltd ("**BioTherm**") acknowledges the presence of pivots on Portion 25 of the Farm Houthaalboomen No. 31 on which the proposed developments are planned to be located. BioTherm understands and respects the importance of agriculture and food production in the area and as such endeavor to protect this unique agricultural land by ensuring that it is a no-go area for development.

BioTherm would like to inform DAFF that the development of the two (2) 75MW Tlisitseng facilities will not disturb any of the pivots located on the proposed development site or in the larger area. We have made great effort to avoid the pivots in the planning of the development areas and as such, the pivots have been marked as no-go areas for the project. The project infrastructure will not cause any disturbance to the pivots. Please see attached to this letter a map of the development area in relation to the pivots.

Further to the above, BioTherm would like to request a meeting with DAFF in order to clarify details of the project development area and answer any questions that DAFF may have with regards to the proposed development.

Please contact Sipehelele Dunga on 011 367 4600 or on sdunga@biothermenergy.com for more details on the project and to set up a meeting time as BioTherm would greatly appreciate the support of DAFF in order for the development to proceed.

Yours Sincerely

A handwritten signature in black ink, appearing to be "Jasandra Nyker", written over a horizontal line.

Jasandra Nyker
Chief Executive Officer

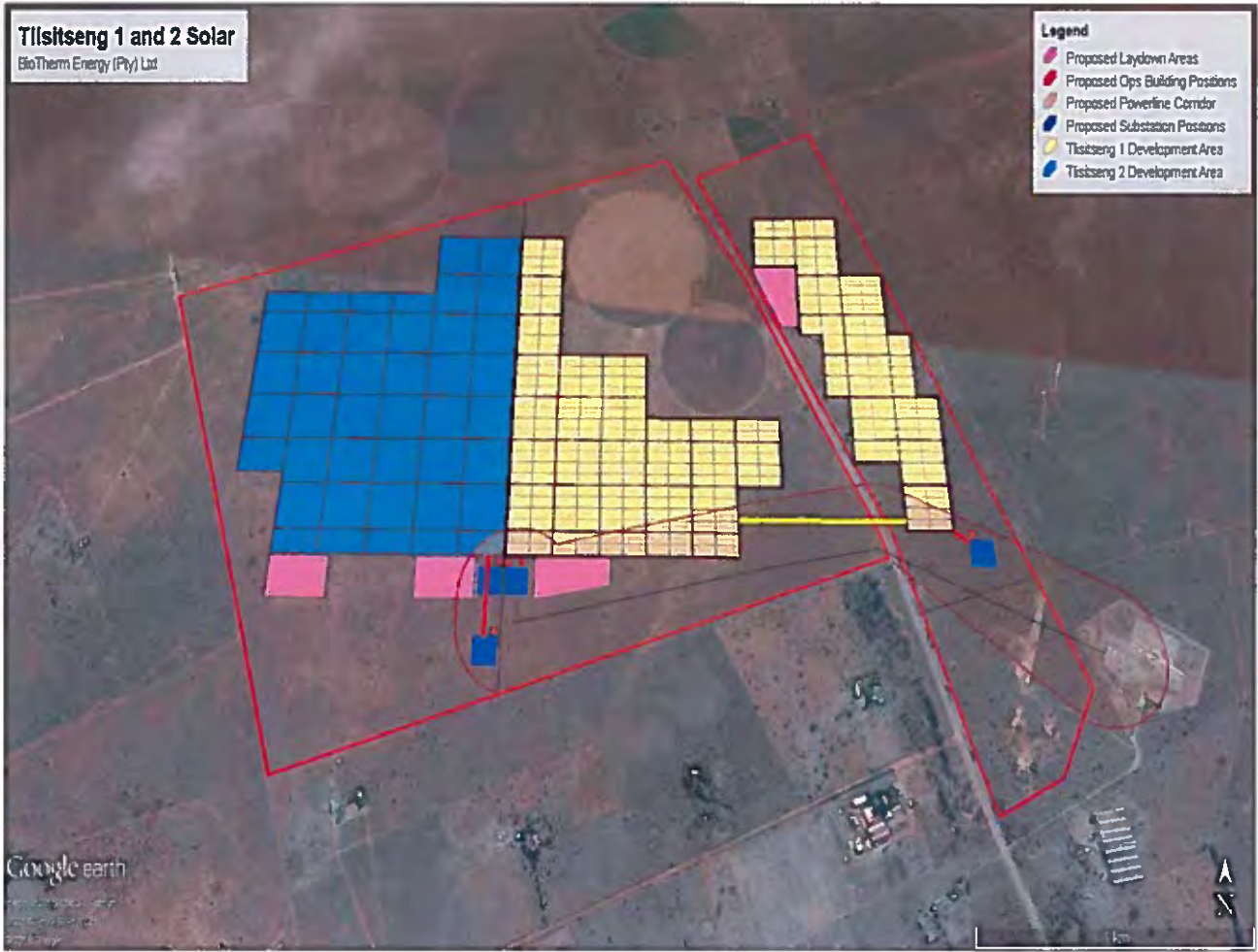

Figure 1. Development area of the proposed 2x75MW Tlitseng Solar Facilities in relation to the pivots.

Cc: DAFF Enquiries- Thoko Buthelezi
SiVest- Andrea Glbb

Lynsey Rimbault

From: Lynsey Rimbault
Sent: 12 April 2016 13:28
To: 'Jan Oliver (NR)'
Subject: RE: Tlisitseng PV Focus Group Meeting
Attachments: A3_13303_Tlisitseng_AllProjects_LowRes.pdf

Dear Jan Oliver,

Please see attached the locality map showing the location of the proposed Tlisitseng Solar PV energy facilities. Please let me know if there is any other information you require.

Kind Regards
Lynsey

Lynsey Rimbault (B.Sc.(Hons) Geography; M.Sc. Biodiversity, Conservation and Management)
Environmental Consultant
SiVEST Environmental



SiVEST is a Level 3 BBBEE Contributor

Direct +27 11 798 0631 **Tel** +27 11 798 0600 **fax** +27 11 803 7272 **cell** +27 82 669 9558
email lynseyr@sivest.co.za **website** www.sivest.co.za



Consulting Engineers - Project Managers - Environmental Consultants - Town and Regional Planners
Durban - Johannesburg - Pietermaritzburg - Richards Bay - Ladysmith - Cape Town - Harare (Zimbabwe)

From: Jan Oliver (NR) [mailto:OliverJ@nra.co.za]
Sent: 08 March 2016 09:24
To: Hlengiwe Ntuli <HlengiweN@sivest.co.za>
Subject: RE: Tlisitseng PV Focus Group Meeting

Dear Rebecca Thomas / Hlengiwe Ntuli

Please email me a locality map showing the location and extent of the two Tlisitseng Solar energy to see whether any national road is affected or not.

Yours sincerely,

Jan Oliver

Statutory Control Section

The South African National Road Agency SOC Limited

Northern Regional Office

38 Ida Street, Menlo Park, Pretoria, 0081

Private Bag X17, Lynnwood Ridge, 0040

Tel: (012) 426 - 6242

Fax: (012) 348 - 1512

Cell: 083 283 6083

e-Mail: oliverj@nra.co.za

www: www.sanral.co.za

From: Hlengiwe Ntuli [<mailto:HlengiweN@sivest.co.za>]

Sent: 07 March 2016 06:17 PM

To: Rebecca Thomas <RebeccaT@sivest.co.za>; Lynsey Rimbault <LynseyR@sivest.co.za>; nicolenev@zitholele.co.za

Cc: 'Kobus Visser' <kobus@agrisa.co.za>; 'Simphiwe Masilela' <SimphiweM@atns.co.za>; 'Johanna Morobane' <JohannaM@atns.co.za>; 'Simon Gear' <advocacy@birdlife.org.za>; 'Godfrey Samore' <gsamore@nwpg.gov.za>; 'Mashudu Marubini' <MashuduMa@daff.gov.za>; 'Anneliza Collett' <annelizac@nda.agric.za>; 'Thoko Buthelezi' <ThokoB@nda.agric.za>; 'Pheladi Masipa' <Pheladi.Masipa@energy.gov.za>; 'Lerato April' <Lerato.April@energy.gov.za>; 'Seoka Lekota' <slekota@environment.co.za>; 'Mmatlala Rabothata' <mrabothata@environment.co.za>; 'Pieter Swart' <Pieter.Swart@dmr.gov.za>; 'Doris Maumela' <MaumelaD@dws.gov.za>; 'Lesego Holele' <lerato.diseko@gmail.com>; 'Pogiso Maitshotlo' <pjmaitshotlo@gmail.com>; 'J Molefe' <digoamajel@mitsobotla.co.za>; 'KRJ Zandamela' <info@mitsobotla.co.za>; 'John Geeringh' <GeerinJH@eskom.co.za>; 'Lourens Leeuwner' <lourensl@ewt.org.za>; 'Mpho Phiri' <phirim@nwpg.gov.za>; 'M W Moholatsi' <fetshangm@moseskotane.co.za>; 'Lehlohonolo March' <matsosel@nmmdm.gov.za>; 'Nono Dince' <gopanel@nmmdm.gov.za>; 'Yoliswa Sechoaro' <msbole@nwpg.gov.za>; 'Alfred Mafune' <ddmogonediswa@nwpg.gov.za>; 'Matshediso Mahlaku' <Matshediso.mahlaku@energy.gov.za>; 'Tebogo Sethosa' <Tebogo.sethosa@energy.gov.za>; 'Bonolo Mohlakoana' <bmohlakoana@nwpg.gov.za>; 'SM Matsheka' <MatshekaS@dwa.gov.za>; 'Lizell Stroh' <strohl@caa.co.za>; 'Harry Roberts' <Robertsh@caa.co.za>; 'Jan Oliver (NR)' <OliverJ@nra.co.za>; 'Shaun Dyers (WR)' <DyersS@nra.co.za>; 'Johan Koegelenberg' <koegelenbergj@sentech.co.za>; 'Chris Nthaudi' <NthaudMC@telkom.co.za>; 'Annette Van Zyl-Swart' <VZylA7@telkom.co.za>; 'Sam Fiff' <Francis.Rahlapane@transnet.net>; 'Suzanne Erasmus' <info@wessa.co.za>; 'Morgan Griffiths' <morgan.griffiths@wessa.co.za>

Subject: Tlisitseng PV Focus Group Meeting

***** Please note that this email was sent from a NO REPLY email address. Please do not reply to this address as it is an unmonitored email account. *****

Dear Stakeholder,

ENVIRONMENTAL IMPACT ASSESSMENT (EIA) AND ENVIRONMENTAL MANAGEMENT PROGRAMME (EMPr) FOR THE TWO TLISITSENG SOLAR PHOTOVOLTAIC (PV) ENERGY FACILITIES, AND BASIC ASSESSMENTS (BA) FOR THE ASSOCIATED SUBSTATIONS AND POWER LINES, NEAR LICHTENBURG, NORTH WEST PROVINCE

DEA Ref. TLISITSENG PV SOLAR 1: 14/12/16/3/3/2/889

TLISITSENG PV SOLAR 2: 14/12/16/3/3/2/890

TLISITSENG 1 SUBSTATION AND POWER LINE: To be confirmed

TLISITSENG 2 SUBSTATION AND POWER LINE: To be confirmed

• INVITATION TO FOCUS GROUP MEETING

This letter serves to cordially invite you to attend a Focus Group Meeting (FGM) that will be held on:

DATE: Monday, 14 March 2016

TIME: 14h00

VENUE: Auditorium of the Ditsobotla Local Municipality Library, Civic Centre, Cnr Nelson Mandela and Transvaal Streets, Lichtenburg

This FGM is part of the Environmental Impact Assessment (EIA) processes being undertaken by SiVEST for the above mentioned projects.

As stakeholder we would value your attendance at the FGM. The purpose of this FGM is to:

- ♣ provide feedback on the impact phase environmental findings;
- ♣ provide the opportunity to raise any questions for clarifications regarding the environmental findings;
- ♣ provide the opportunity to raise any comments and/or concerns regarding this proposed project; and

♣ record your comments and/or concerns raised at the FGM.

To ensure that sufficient seating is provided at the venue, we kindly request that you complete the attached Registration Form and return it to the Public Participation team on or before Thursday, 10 March 2016.

Please also note that a Public Meeting is being held on the evening of Monday, 14 March 2016 at Lichtenburg Town Hall / Soepe Hall on Nelson Mandela Drive, Lichtenburg at 18h00.

Please feel free to pass this invitation to any other relevant officials from your Department as you deem necessary. We are looking forward to your attendance and meaningful contributions.

Kind Regards,

REBECCA THOMAS (B.Sc Env. Sc.; PDM Business Management) Senior Environmental Scientist
SiVEST Environmental Division

SiVEST is a Level 3 BBBEE Contributor

direct +27 11 798 0634 tel +27 11 798 0600 fax +27 11 803 7272 cell +27 82 302 9010
email rebeccat@sivest.co.za website www.sivest.co.za

Consulting Engineers - Project Managers - Environmental Consultants - Town and Regional Planners
Durban - Johannesburg - Pietermaritzburg - Richards Bay - Ladysmith - Cape Town - Harare (Zimbabwe)

SiVEST is a Level 3 BBBEE Contributor

Direct +27 11 798 0691 Tel +27 11 798 0600 fax +27 11 803 7272 cell +27 72 779 4899
email shaunt@sivest.co.za website www.sivest.co.za

Consulting Engineers - Project Managers - Environmental Consultants - Town and Regional Planners
Durban - Johannesburg - Pietermaritzburg - Richards Bay - Ladysmith - Cape Town - Harare (Zimbabwe)

Disclaimer

The information contained in this communication from the sender is confidential. It is intended solely for use by the recipient and others authorized to receive it. If you are not the recipient, you are hereby notified that any disclosure, copying, distribution or taking action in relation of the contents of this information is strictly prohibited and may be unlawful.

This email has been scanned for viruses and malware, and automatically archived by Mimecast SA (Pty) Ltd, an innovator in Software as a Service (SaaS) for business. Mimecast Unified Email Management ??? (UEM) offers email continuity, security, archiving and compliance with all current legislation. To find out more, [contact Mimecast](#).

Disclaimer:

This message contains confidential information and is intended only for the individual named.

If you are not the named addressee you should not disseminate, distribute or copy this e-mail.

Please notify the sender immediately by e-mail if you have received this e-mail by mistake and delete this e-mail from your system. E-mail transmission cannot be guaranteed to be secure or without errors as information could be intercepted, corrupted, lost, destroyed, arrive late or incomplete, or contain viruses.

The sender therefore does not accept liability for any errors or omissions in the contents of this message, which arise as a result of e-mail transmission.

If verification is required please request a hard-copy version. The South African National Roads Agency SOC Ltd, PO Box 415, Pretoria, 0001, South Africa, Tel +27-(0)12 844 8000, www.nra.co.za.

This Disclaimer is deemed to form part of the content of this email in terms of Section 11 of the Electronic Communications and Transactions Act, 25 of 2002.

Lynsey Rimbault

From: Lynsey Rimbault
Sent: 07 March 2016 14:47
To: 'VZylA7@telkom.co.za'; 'FerreiJP@telkom.co.za'
Cc: Hlengiwe Ntuli
Subject: RE: Tlisitseng Solar PV projects Final Scoping Reports submitted to the DEA
Attachments: 13303_T_Project1_PVArray_Alternatives.kml; 13303_T_Project2_PVArray_Alternatives.kml; A3_13303_Tlisitseng_Project2_ProposedLayout_Reduced.jpg; A3_13303_Tlisitseng_Project1_ProposedLayout_Reduced.jpg; Tlisitseng Notification FSR to DEA Rev1_19Feb2016 LR.PDF

Hi Annette,

Apologies for the delayed reply. Please see attached the notification letter, kmls and maps of the proposed Tlisitseng PV projects.

Let me know if you require any further information.

Kind Regards
Lynsey

Lynsey Rimbault (B.Sc.(Hons) Geography; M.Sc. Biodiversity, Conservation and Management)
Environmental Consultant
SiVEST Environmental



SiVEST is a Level 3 BBBEE Contributor

Direct +27 11 798 0631 Tel +27 11 798 0600 fax +27 11 803 7272 cell +27 82 669 9558
email lynseyr@sivest.co.za website www.sivest.co.za



Consulting Engineers - Project Managers - Environmental Consultants - Town and Regional Planners
Durban - Johannesburg - Pietermaritzburg - Richards Bay - Ladysmith - Cape Town - Harare (Zimbabwe)

From: Annette Van Zyl-Swart (A) [<mailto:VZylA7@telkom.co.za>]
Sent: 22 February 2016 09:15 AM
To: Hlengiwe Ntuli <HlengiweN@sivest.co.za>
Cc: Johan Ferreira (JP) <FerreijP@telkom.co.za>
Subject: FW: Tlisitseng Solar PV projects Final Scoping Reports submitted to the DEA

Goodday,

Can we have a sketch and letter for this application of yours.
Will you need indication of where our infrastructure is?

Regards,

Annette van Zyl-Swart
Planner (Highload Clearances, Wayleave & Poles SPOC MMB DSSU)

Openserve – 30 Electron Rd Uraniaville, Klerksdorp
Tel – 018 469 6517
Cell – 081 536 4727
Fax to Email – 086 569 8345
Office Fax – 018 469 6528
vzyla7@telkom.co.za



From: Chris Nthaudi (MC)
Sent: Friday, February 19, 2016 3:51 PM
To: Hlengiwe Ntuli; Annette Van Zyl-Swart (A)
Cc: Rebecca Thomas; Lynsey Rimbault; nicolenev@zitholele.co.za
Subject: RE: Tlisitseng Solar PV projects Final Scoping Reports submitted to the DEA

From: Hlengiwe Ntuli [<mailto:HlengiweN@sivest.co.za>]
Sent: 19 February 2016 03:48 PM
Cc: Rebecca Thomas; Lynsey Rimbault; nicolenev@zitholele.co.za
Subject: Tlisitseng Solar PV projects Final Scoping Reports submitted to the DEA

***** Please note that this email was sent from a NO REPLY email address. Please do not reply to this address as it is an unmonitored email account. *****

Dear Interested and/or Affected Party

ENVIRONMENTAL IMPACT ASSESSMENT (EIA) AND ENVIRONMENTAL MANAGEMENT PROGRAMME (EMPr) FOR THE TWO TLISITSENG SOLAR PHOTOVOLTAIC (PV) ENERGY FACILITIES NEAR LICHTENBURG, NORTH WEST PROVINCE

DEA Ref. TLISITSENG PV SOLAR 1: 14/12/16/3/3/2/889
TLISITSENG PV SOLAR 2: 14/12/16/3/3/2/890

* FSR AVAILABLE FOR REVIEW

We wish to express our appreciation to the stakeholders who submitted comments on the Draft Scoping Reports (DSRs) for the above mentioned proposed projects during the public review period (Monday 11 January 2016 to Tuesday 9 February 2016). After the public review period, the DSRs were updated, taking into consideration the issues and concerns raised by stakeholders.

The Final Scoping Reports (FSRs) were submitted to the Department of Environmental Affairs (DEA) for their consideration on Friday 19 February 2016.

In accordance with the National Environmental Management Act (NEMA), the FSRs will be available for public comment and review from Monday 22 February 2016 to Monday 7 March 2016 (end of business day). The FSRs are available on SiVEST's website: <http://www.sivest.co.za/> click on 'Downloads' (top right), then scroll down to 13303 Tlisitseng PV Energy Development. Alternatively, please contact SiVEST to obtain an electronic copy of the reports on CD.

Should you have any comments on the FSRs, please submit these in writing directly to the DEA on or before Monday 7 March 2016 (close of business day):

Department of Environmental Affairs (DEA)
Ms. Mmamohale Kabasa
Private Bag X447
PRETORIA
0001
Tel: 012 399 9420
Email: MKabasa@environment.gov.za

As per the EIA Regulations, please send a copy of your comments to the SiVEST Office at the following address:

SiVEST Environmental
Lynsey Rimbault
PO BOX 2921
Rivonia
2128
Tel: 011 798 0600
Fax: 011 803 7272
Email: lynseyr@sivest.co.za

Kind Regards,

REBECCA THOMAS (B.Sc Env. Sc.; PDM Business Management)
Senior Environmental Scientist
SiVEST Environmental Division

SiVEST is a Level 3 BBBEE Contributor

direct +27 11 798 0634 tel +27 11 798 0600 fax +27 11 803 7272 cell +27 82 302 9010
email rebeccat@sivest.co.za website www.sivest.co.za

Consulting Engineers - Project Managers - Environmental Consultants - Town and Regional Planners
Durban - Johannesburg - Pietermaritzburg - Richards Bay - Ladysmith - Cape Town - Harare (Zimbabwe)

Disclaimer

The information contained in this communication from the sender is confidential. It is intended solely for use by the recipient and others authorized to receive it. If you are not the recipient, you are hereby notified that any disclosure, copying, distribution or taking action in relation of the contents of this information is strictly prohibited and may be unlawful.

This email has been scanned for viruses and malware, and automatically archived by Mimecast SA (Pty) Ltd, an innovator in Software as a Service (SaaS) for business. Mimecast Unified Email Management ??? (UEM) offers email continuity, security, archiving and compliance with all current legislation. To find out more, [contact Mimecast](#).

~~~~~  
This e-mail is subject to the Telkom SA SOC Ltd electronic communication legal notice,  
available at : <http://www.telkom.co.za/TelkomEMailLegalNotice.PDF>  
~~~~~

Lynsey Rimbault

From: Lynsey Rimbault
Sent: 07 March 2016 14:59
To: 'GeerinJH@eskom.co.za'
Cc: Hlengiwe Ntuli
Subject: RE: Tlisitseng Solar PV projects Final Scoping Reports submitted to the DEA
Attachments: 13303_S_Project2_PVArray.kml; 13303_S_Project3_PVArray.kml; 13303_S_Project1_PVArray.kml; 13303_T_Project2_PVArray_Alternatives.kml; 13303_T_Project1_PVArray_Alternatives.kml; 13303_Tlisitseng_PL_Project2_08Feb2016.kml; 13303_Tlisitseng_PL_Project1_08Feb2016.kml; 13303_Sendawo_EIAPhase_Alternatives.kml

Dear John,

Apologies for the delayed reply.

Please see attached the kmls for the site boundaries for the 5 PV projects. The layout alternatives have not yet been finalised, this will be done during the EIA phase of the projects. Please also find kmls for the power line corridors and proposed substation sites for the 3 Grid connection projects.

Kind Regards
Lynsey Rimbault

Lynsey Rimbault *(B.Sc.(Hons) Geography; M.Sc. Biodiversity, Conservation and Management)*
Environmental Consultant
SiVEST Environmental



SiVEST is a Level 3 BBBEE Contributor

Direct +27 11 798 0631 Tel +27 11 798 0600 fax +27 11 803 7272 cell +27 82 669 9558
email lynseyr@sivest.co.za website www.sivest.co.za



Consulting Engineers - Project Managers - Environmental Consultants - Town and Regional Planners
Durban - Johannesburg - Pietermaritzburg - Richards Bay - Ladysmith - Cape Town - Harare (Zimbabwe)

From: John Geeringh [<mailto:GeerinJH@eskom.co.za>]
Sent: 22 February 2016 10:51 AM
To: Hlengiwe Ntuli <HlengiweN@sivest.co.za>
Subject: RE: Tlisitseng Solar PV projects Final Scoping Reports submitted to the DEA

Can you please send me KMZ files of the sites, layouts and line routes for the proposed power lines for my records and proper checking against our plans. Can you also send me the Sendawo KMZ files? I would appreciate it very much.

Regards
John

From: Hlengiwe Ntuli [<mailto:HlengiweN@sivest.co.za>]
Sent: 19 February 2016 03:48 PM
Cc: Rebecca Thomas; Lynsey Rimbault; nicolenev@zitholele.co.za
Subject: Tlisitseng Solar PV projects Final Scoping Reports submitted to the DEA

***** Please note that this email was sent from a NO REPLY email address. Please do not reply to this address as it is an unmonitored email account. *****

Dear Interested and/or Affected Party

ENVIRONMENTAL IMPACT ASSESSMENT (EIA) AND ENVIRONMENTAL MANAGEMENT PROGRAMME (EMPr) FOR THE TWO TLISITSENG SOLAR PHOTOVOLTAIC (PV) ENERGY FACILITIES NEAR LICHTENBURG, NORTH WEST PROVINCE

DEA Ref. TLISITSENG PV SOLAR 1: 14/12/16/3/3/2/889

TLISITSENG PV SOLAR 2: 14/12/16/3/3/2/890

* FSR AVAILABLE FOR REVIEW

We wish to express our appreciation to the stakeholders who submitted comments on the Draft Scoping Reports (DSRs) for the above mentioned proposed projects during the public review period (Monday 11 January 2016 to Tuesday 9 February 2016). After the public review period, the DSRs were updated, taking into consideration the issues and concerns raised by stakeholders.

The Final Scoping Reports (FSRs) were submitted to the Department of Environmental Affairs (DEA) for their consideration on Friday 19 February 2016.

In accordance with the National Environmental Management Act (NEMA), the FSRs will be available for public comment and review from Monday 22 February 2016 to Monday 7 March 2016 (end of business day). The FSRs are available on SiVEST's website: <http://www.sivest.co.za/> click on 'Downloads' (top right), then scroll down to 13303 Tlisitseng PV Energy Development. Alternatively, please contact SiVEST to obtain an electronic copy of the reports on CD.

Should you have any comments on the FSRs, please submit these in writing directly to the DEA on or before Monday 7 March 2016 (close of business day):

Department of Environmental Affairs (DEA)
Ms. Mmamohale Kabasa
Private Bag X447
PRETORIA
0001
Tel: 012 399 9420
Email: MKabasa@environment.gov.za

As per the EIA Regulations, please send a copy of your comments to the SiVEST Office at the following address:

SiVEST Environmental
Lynsey Rimbault
PO BOX 2921
Rivonia
2128
Tel: 011 798 0600
Fax: 011 803 7272
Email: lynseyr@sivest.co.za

Kind Regards,

REBECCA THOMAS (B.Sc Env. Sc.; PDM Business Management)
Senior Environmental Scientist
SiVEST Environmental Division

SiVEST is a Level 3 BBBEE Contributor

direct +27 11 798 0634 tel +27 11 798 0600 fax +27 11 803 7272 cell +27 82 302 9010
email rebeccat@sivest.co.za website www.sivest.co.za

Consulting Engineers - Project Managers - Environmental Consultants - Town and Regional Planners
Durban - Johannesburg - Pietermaritzburg - Richards Bay - Ladysmith - Cape Town - Harare (Zimbabwe)

Disclaimer

The information contained in this communication from the sender is confidential. It is intended solely for use by the recipient and others authorized to receive it. If you are not the recipient, you are hereby notified that any disclosure, copying, distribution or taking action in relation of the contents of this information is strictly prohibited and may be unlawful.

This email has been scanned for viruses and malware, and automatically archived by Mimecast SA (Pty) Ltd, an innovator in Software as a Service (SaaS) for business. Mimecast Unified Email Management ??? (UEM) offers email continuity, security, archiving and compliance with all current legislation. To find out more, [contact Mimecast](#).

I'm part of the 49Million initiative...
<http://www.49Million.co.za>

NB: This Email and its contents are subject to the Eskom Holdings SOC Limited EMAIL LEGAL NOTICE which can be viewed at http://www.eskom.co.za/Pages/Email_Legal_Spam_Disclaimer.aspx

Andrea Gibb

From: Carmen Barends <carmenb@l2b.co.za>
Sent: Friday, 24 February 2017 12:29 PM
To: Hlengiwe Ntuli; Andrea Gibb
Subject: Tlisitseng Solar 1 & 2 and Powerlines

Hello Hlengiwe,

I hope you are well.

Please could you advise whether the amended EA has been approved as yet?

Thank you kindly.

--

Kind Regards,

Carmen Barends
Regional Content Researcher
Private Projects

Leads 2 Business (www.L2B.co.za)

Tel: 033 343 1130 or 0860 836337 (0860 TENDER)

Fax: 033 343 5882

This e-mail is for the intended addressee only. If you have received it in error, please notify the sender by e-mail. Dissemination or copying is prohibited unless permitted by the sender, and then only by the intended addressee. Whilst reasonable measures are used to guard against the transmission of malicious code, no liability is accepted for its transmission. If this e-mail is not related to the business of Cedrus Internet Solutions (Pty) Ltd, it is sent by the above mentioned in their individual capacity and not on behalf of Cedrus Internet Solutions (Pty) Ltd.

Please note that any views expressed in this email may be those of the originator and do not necessarily reflect those of Cedrus Internet

EIAs FOR THE PROPOSED DEVELOPMENT OF THE TWO (2) TLISITSENG 75MW SOLAR PHOTOVOLTAIC (PV) ENERGY FACILITIES, AND BAs FOR THE ASSOCIATED 132kV POWER LINES NEAR LICHTENBURG, NORTH WEST PROVINCE

Public Participation Office



Andrea Gibb
 SIVEST Environmental
 PO Box 2921, RIVONIA, 2128
 Tel (011) 798 0600
 Fax (011) 803 7272
 Email andreag@sivest.co.za

REGISTRATION AND COMMENT FORM

Draft Scoping Reports (DSRs)
 29 September 2016 – 31 October 2016



WE WOULD WELCOME YOUR COMMENTS ON THE DSRs

Please complete by Monday 31 October 2016 (end of business day), and return to the Public Participation Office (as above)

TITLE	MR	FIRST NAME	MARK
INITIALS	M.A.	SURNAME	HECHTER
ORGANISATION	NEIGHBOUR	EMAIL	mhechter@sepcew.co.za
POSTAL ADDRESS	P.O. BOX 1631, LICHTENBURG, 2740		
		POSTAL CODE	2740
TEL NO	083 651 7659	FAX NO	

COMMENTS: (You are welcome to use a separate sheet if required)

I have the following issues and concerns regarding the DSRs – Please refer to the relevant section in the report.

PROXIMITY OF ACTIVITY
 VISUAL ISSUES AFFECTING LIFESTYLE AS WELL
 AS BUSINESS
 PLEASE REFER TO LETTER SUBMITTED BY MYSELF
 ON 23 JUNE 2016. THIS LETTER WAS SUBMITTED
 TO EXPLAIN MY ISSUES WITH THE PROJECT

Signature

THANK YOU FOR YOUR CONTRIBUTION

Date

Andrea Gibb

From: Carmen Barends <carmenb@l2b.co.za>
Sent: Wednesday, August 24, 2016 9:10 AM
To: Andrea Gibb
Subject: Tlitseng Solar 1 & 2 and Powerlines

Good day Andrea,

I hope you are well.

Please could you advise whether the final EIA report is available as yet for the above projects or what progress has been made?

Thank you kindly.

--

Kind Regards,

Carmen Barends
Regional Content Researcher
Private Projects

Leads 2 Business (www.L2B.co.za)

Tel: 033 343 1130 or 0860 836337 (0860 TENDER)

Fax: 033 343 5882

This e-mail is for the intended addressee only. If you have received it in error, please notify the sender by e-mail. Dissemination or copying is prohibited unless permitted by the sender, and then only by the intended addressee. Whilst reasonable measures are used to guard against the transmission of malicious code, no liability is accepted for its transmission. If this e-mail is not related to the business of Cedrus Internet Solutions (Pty) Ltd, it is sent by the above mentioned in their individual capacity and not on behalf of Cedrus Internet Solutions (Pty) Ltd.

Please note that any views expressed in this email may be those of the originator and do not necessarily reflect those of Cedrus Internet

Andrea Gibb

From: Mark Hechter <mhechter@sepcem.co.za>
Sent: Thursday, June 30, 2016 5:06 PM
To: Andrea Gibb
Subject: Proposed solar Farm Project
Attachments: Andries brief.rtf; Appeal against Solar Project - 23 June 2016.pdf; Vrae Nagaande Die Projek.rtf

Dear Andrea

Attached are letters of appeal against the proposed solar farm project in the Lichtenburg area. There are still one or two letters to come, but I will send them tomorrow. Would like to try and get them signed.

Attached is a letter from myself as well as one other owner. The list of questions are from the other owners adjacent to the proposed project. They would like these answered please.

Hoping for your fair consideration

Regards

Mark Hechter
Aganang Plant Manager

M : +27 83 651 7659
T : +27 18 633 4400 (Switchboard)
T : +27 18 633 4410 (Direct)
F : +27 18 633 4695

mhechter@sepcem.co.za
www.sephakucement.co.za



Navrae oor die projek

1. Watse profeit word voorspel vir die lang termyn?
2. Indien ons van ons grond sou wou verkoop, watse persoon sal verantwoordelik wees vir die waardering van die grond en wie gaan die kostes dek? Die waarde van die grond gaan afneem.
3. Hoe gaan die projek die huidige werknemers, wat naby die geïdentifiseerde area woon, beïnvloed? Aangesien die woon area van die werknemers deur die projek beperk word.
4. Indien daar toekomstig verdere uitbreidings gaan wees, hoe sal dit die plot eienaars affekteer?

Van: Gys Goedhals ^① Dat: 25 Junie 2016
Posbus 630
Lichtenburg
2740

Aandag: Vir die persoon wat dit mag raangaan.

Is: Konstruksie van 'n Skopplaas op 'n gedeelte van my plaas. (P.J.N. 25 van Houtkwaliteitswettiging nō 31)

Geagte Andrea Gibb,

"Hoe" staalstrukture wat opgerig sal word veroorsaak die volgende gevolge.

- 1 a) Onooglike uitsig van die natuur op my plaas.
- b) Veroorsaak wrektes van wildlewe soos bv. aasvoëls wat in oorhoofse kabele vas stieg.
- c) Verwilder klein wild bv. Bakoorjakkalsies, duikers en steenbokkies.
- d) Veroorsaak veldbrande
- e) Indien ek dit vir enige koper van my grond soos oopbaar, soos die goeie praktyk is, sal dit hom afskrik. Die waarde van die grond sal dus aangetas word.

2. Daar word gemeld dat daar 'n publieke vergadering gehou is. Watter insette is gelever en ek versoek dat punte wat geopper is aan my oopbaar word. (In AFRIKAANS)

3. Dit sal toegang gee aan ongewenste persone en werkers wat ons privaatheid en veiligheid bedreig.

Bl. 2

- 4a) Hiermee versoek ek, ⁽²⁾ dat in Natuur impak-studie in Afrikaans aan ons beskikbaar gestel moet word.
- 4b) Waar is die publieke vergadering gêduurteer (in watter korant)
- 5) Dit sal toekomstige ontwikkeling hierdie hoeve aantas, omdat daar nie 'n heining opgerig kan word sonder tekke nie, en wat gereeld deur werkers oopgelaat sal word nie.
6. Die sekuriteitsaspek bekommer my ook. Ons woon sedert 1980 op die perseel. Ons het hierheen verhuis vir die rus en vrede van die omgewing om die geraas en verkeer van die dorp te ontduik, en die skoonheid van die natuur te waardeer.
7. Oprigting van tydelike woonkwartiere en tielt-te? Wat is impak gaan dit op die grond en water hê?
8. Indien sonpannele sou breek wat gebeur met die afval en maandelike skoei stouwe wat die grondwater besoedel?
9. Die diagramme wat beskikbaar gestel is, is veroudend en nie betroubaar nie
10. Ons vereis dat 'n vergadering belê word, sodat betrokke persone insette kan lewer en vernoemde punte bespreek kan word.
11. Wat is effek sal die uitstraling op die gesondheid van die bewoners hê?
12. Ek wil dit baie duidelik stel dat ek ten gunste van so 'n ontwikkeling is,
- Volg bl. 3.

(3)

Hierdie ontwikkeling kan verskuif word die korridor en die res van die mooglike ontwikkeling op PTM 25 Van Houtkoolboomen geleë is.

(13) Hiermee verklaar ek as eienaar van houe 3 van die plaas Talene 25 IP Dist Ktx is en dat ek geensins my toestemming gee vir die ontwikkeling soos dit huidige daar uitsien nie.

14. Aangesien d. ontwikkeling op 'n gedeelte van my grond val, stel ek voor dat julle die hele houe moet koop teen die prys deur ons bepaal.

Byvoorbaat dankie



Gys Goedhals

Postbus 630 Richtenburg 2740

Faks 086 690 0184 E-pos

Tel: 082-636-7902. gysgoedhals@gmail.com

Erken asseblief ontvangs van hierdie brief.

ANDRIES VAN ROOYEN

Sel. 083 448 9078

24 Junie 2016

Goeie dag ANDREA

Re: *Ontwikkeling op **(P.T.N. 25 VAN HOUTHAALBOOMEN NO.31)**

Ek maak beslis beswaar teen hierdie ontwikkeling van die Power line Corridor (Projek 1). Dit is op n gedeelte van my eiendom.

1. Indien ek dit vir enige koper van my grond sal openbaar, soos die praktyk is, sal dit hom afskrik. Die waarde van my grond word dus aangetas deur die voorgestelde kraglyne wat daarvoor sal loop. Die Korridor sal dus veroorsaak dat die algemene gebruik van die grond sal daal.
2. Dit sal toegang gee aan ongewenste persone en werkers wat ons privaatheid kan bedreig
3. Dit sal die toegekende ontwikkeling op hierdie perseel aantas omdat daar nie n heining opgerig kan word sonder hekke nie.
4. Die sekuriteitsaspek bekommer my ook. Ons woon al baie lank op die perseel. Ons het hierheen verhuis om in 'n rustige omgewing te verkeer en die natuur te waardeer.
5. Ek wil dit baie duidelik stel ek is ten gunste van so ontwikkeling, maar nie op my grond nie. Hierdie ontwikkeling kan verskuif word dat die korridor en die res van die onooglike ontwikkeling op PTN 25 VAN HOUTHAALBOOMEN gelee is.

6. Hiermee verklaar ek dat ek die eienaar is van Hoewe 2 van die plaas Talene 25 IP, Dist. Lichtenburg en dat ek geensins toestemming gee vir die ontwikkeling soos dit huidiglik is nie.

Dankie

Andries van Rooyen

FROM : Mark Hechter

DATE : 2011-07-25

ATTENTION : To Whome it May Concern

SUBJECT : **Proposed Construction of Solar Farm close to
Talene Small Holdings**

Herewith I would like to formally appeal against the building of above-mentioned Project.

My property is 1 Talene, which is adjacent to the above-mentioned project, and is thus directly impacted by the building of the proposed solar farm.

I purchased this property some 12 odd years ago. I did this as was interested in living outside of town to the get the tranquillity of the outside life, and also to begin building a business on the property.

If this solar project were to continue this would impact my view of the veld around me, and would negate one of the reasons I moved out to the farm in the first place.

We are also in the process of building an entertainment business on the property. I have already secured business rights for a portion of the property where we are developing it. We have, thusfar, built the pub, and expanded it to the point where it is now a going concern, with a regular customer base. There is also a well-established pool club at the venue, which is one of the biggest Clubs in North West. There is also a kitchen for visitors to eat from, and we have also developed a paintball course in the veld close to where the proposed solar farm is to be built.

It is our full intention to further develop this business to include the following:

1. A Boma area for visitors to use and which we will rent out to prospective customers and smaller business's in the Lichtenburg area. This will be in the veld and will be available as a function venue for private persons as well as business's. Part of the draw for this will be the outside veld, and rustic atmosphere so created.
2. Chalets. These will be self-catering chalets for persons staying over for a longer or shorter period. Again, the main attraction for these will be the outside life, and the view of the veld and the sunsets which Are absolutely spectacular in the area.
3. We intend to eventually increasing the size of the pub to have an viewing area toward the paintball, which will

include the veld, and will be a great spot for sundowners, and a relaxing atmosphere.

The above will not be possible if the solar farm is built in the area.

A further negative impact on myself would be the extra feet which would now be close to our area. I have sheep and cattle, which are part of my and my son's developing business. With extra feet adjacent to our property this is going to increase our security risk, and could possibly put our animals and our visitors at risk. The current environment in South Africa makes this a reality, and being able to give people a safe getaway area is absolutely crucial to the business development working.

The installation of the solar farm would negatively impact the value of my property, as the main reasons for having the property would be in jeopardy, the view, safety and tranquillity of the area.

I am also in the process of developing an African Grey farming business. We have built 4 cages, and are currently expanding these into 8 cages. We have ordered our first two pairs of African Greys. The extra activity in the area could negatively impact on this business.

Above are my main reasons for NOT supporting the Solar Farm initiative in our area.

We, as landowners, should be given a fair opportunity to develop our own business's as well. The solar farm project will negatively impact our ability to develop our own business's. And quite honestly, we were here first!

There are many other areas to develop the solar project. For example, it could be built deeper into the property of the current owner, so that it could not be seen at all by our property owners, and would not have as big an effect on our security concerns.

I genuinely hope that we as, landowners will be taken seriously with our concerns. We enjoy where we live, and want to stay on and develop the properties. Please do not destroy this opportunity for us.

Yours Sincerely

A handwritten signature in black ink, appearing to read 'Mark Hechter', with a long horizontal flourish extending to the right.

MARK HECHTER
OWNER OF 1 TALENE

Dear Andrea Gibb

22 June 2016

Environmental impact phase of the Tlisitseng phase 1 and 2 Solar Photovoltaic Energy Facilities

With regard to the above mentioned I would like to express my dissatisfaction regarding the proposed Power line Corridor (Project 1) crossing through a portion of my property.

Thus it will cover ,plus minus, one third of my property influencing future plans I have for that specific section.

NB!! I Fazel Variawa here by do not give consent towards any development such as the powerlines and servitude road through my property.

Proposal

I suggest that the power lines be established on property (PTN 25 of Houthaalboomen No.31). Seeing that the project as a whole is going to be established on the fore said property.

Kind regards

Fazel VarVariawa

Andrea Gibb

From: Andrea Gibb
Sent: Wednesday, 08 March 2017 2:36 PM
To: 'Gys Goedhals'
Subject: 13303: Tlitseng Power Line Maps
Attachments: A3_13303_T1PL_RouteOverview_Reduced.jpg; A3_13303_T2PL_RouteOverview_Reduced.jpg

Hi Gys

As per your request, attached are the maps showing the power line assessment corridors in relation to the neighbouring farms. As indicated the corridors have been adjusted so that they do not traverse the neighbouring Talene Farms.

Kind Regards

Andrea Gibb (B.Sc. Landscape Architecture; B.Sc.(Hons) Environmental Management)

Environmental Practitioner and Visual Specialist

SiVEST Environmental Division



SiVEST is a Level 3 BBBEE Contributor

Direct +27 11 798 0638 **Tel** +27 11 798 0600 **fax** +27 11 803 7272 **cell** +27 72 587 6525
email andreaq@sivest.co.za **website** www.sivest.co.za



Consulting Engineers - Project Managers - Environmental Consultants - Town and Regional Planners
Durban - Johannesburg - Pietermaritzburg - Richards Bay - Ladysmith - Cape Town - Harare (Zimbabwe)

Andrea Gibb

From: Andrea Gibb
Sent: Monday, 27 February 2017 10:02 AM
To: Carmen Barends
Cc: Hlengiwe Ntuli
Subject: RE: Tlisitseng Solar 1 & 2 and Powerlines

Importance: High

Follow Up Flag: Follow up
Flag Status: Completed

Hi Carmen

The process is still underway. The Final Scoping Reports for the solar facilities were accepted by the DEA and the Draft Environmental Impact Assessment Reports and Draft Basic Assessment Reports for the power lines will be released for public review in March 2017. You will be notified accordingly once the reports are available for review.

Kind Regards

Andrea Gibb (*B.Sc. Landscape Architecture; B.Sc.(Hons) Environmental Management*)
Environmental Practitioner and Visual Specialist
SiVEST Environmental Division



SiVEST is a Level 3 BBBEE Contributor

Direct +27 11 798 0638 **Tel** +27 11 798 0600 **fax** +27 11 803 7272 **cell** +27 72 587 6525
email andrea@sivest.co.za **website** www.sivest.co.za



Consulting Engineers - Project Managers - Environmental Consultants - Town and Regional Planners
Durban - Johannesburg - Pietermaritzburg - Richards Bay - Ladysmith - Cape Town - Harare (Zimbabwe)

From: Carmen Barends [mailto:carmenb@l2b.co.za]
Sent: Friday, 24 February 2017 12:29 PM
To: Hlengiwe Ntuli <HlengiweN@sivest.co.za>; Andrea Gibb <AndreaG@sivest.co.za>
Subject: Tlisitseng Solar 1 & 2 and Powerlines

Hello Hlengiwe,

I hope you are well.

Please could you advise whether the amended EA has been approved as yet?

Thank you kindly.

--

Kind Regards,

Carmen Barends
Regional Content Researcher
Private Projects

Leads 2 Business (www.L2B.co.za)

Tel: 033 343 1130 or 0860 836337 (0860 TENDER)

Fax: 033 343 5882

This e-mail is for the intended addressee only. If you have received it in error, please notify the sender by e-mail. Dissemination or copying is prohibited unless permitted by the sender, and then only by the intended addressee. Whilst reasonable measures are used to guard against the transmission of malicious code, no liability is accepted for its transmission. If this e-mail is not related to the business of Cedrus Internet Solutions (Pty) Ltd, it is sent by the above mentioned in their individual capacity and not on behalf of Cedrus Internet Solutions (Pty) Ltd.

Please note that any views expressed in this email may be those of the originator and do not necessarily reflect those of Cedrus Internet

Andrea Gibb

From: Andrea Gibb
Sent: Wednesday, August 24, 2016 12:37 PM
To: 'Carmen Barends'
Subject: RE: Tlisitseng Solar 1 & 2 and Powerlines

Gooday Carmen

Please note the applications for environmental authorisation for the Tlisitseng Solar PV Facilities have lapsed as the legislated timeframes could not be adhered to due to a layout change which affected both projects.

As such, applications for environmental authorisation will be resubmitted to the DEA and the project will restart in September 2016.

You will be notified as the project progresses.

Kind Regards

Andrea Gibb (B.Sc. Landscape Architecture; B.Sc.(Hons) Environmental Management)
Environmental Practitioner and Visual Specialist
SIVEST Environmental Division



SIVEST is a Level 3 BBBEE Contributor

Direct +27 11 798 0638 **Tel** +27 11 798 0600 **fax** +27 11 803 7272 **cell** +27 72 587 6525
email andrea@sivest.co.za **website** www.sivest.co.za



Consulting Engineers - Project Managers - Environmental Consultants - Town and Regional Planners
Durban - Johannesburg - Pietermaritzburg - Richards Bay - Ladysmith - Cape Town - Harare (Zimbabwe)

From: Carmen Barends [mailto:carmenb@l2b.co.za]
Sent: Wednesday, August 24, 2016 9:10 AM
To: Andrea Gibb <AndreaG@sivest.co.za>
Subject: Tlisitseng Solar 1 & 2 and Powerlines

Good day Andrea,

I hope you are well.

Please could you advise whether the final EIA report is available as yet for the above projects or what progress has been made?

Thank you kindly.

--

Kind Regards,

Carmen Barends
Regional Content Researcher
Private Projects

Leads 2 Business (www.L2B.co.za)

Tel: 033 343 1130 or 0860 836337 (0860 TENDER)

Fax: 033 343 5882

This e-mail is for the intended addressee only. If you have received it in error, please notify the sender by e-mail. Dissemination or copying is prohibited unless permitted by the sender, and then only by the intended addressee. Whilst reasonable measures are used to guard against the transmission of malicious code, no liability is accepted for its transmission. If this e-mail is not related to the business of Cedrus Internet Solutions (Pty) Ltd, it is sent by the above mentioned in their individual capacity and not on behalf of Cedrus Internet Solutions (Pty) Ltd.

Please note that any views expressed in this email may be those of the originator and do not necessarily reflect those of Cedrus Internet

Andrea Gibb

From: Nicolene Venter <nicolenev@zitholele.co.za>
Sent: Thursday, June 30, 2016 6:44 PM
To: gysgoedhals@gmail.com
Cc: Lynsey Rimbault; Andrea Gibb; iafrica@icon.co.za
Subject: TLISITSENG SOLAR PROJEK - Ontvangserkenning van Skrywe

Goeie naand Gys,

Namens die projekspan erken ons ontvangs van jou skrywe soos aangeheg by jou e-pos gedateer 30 Junie 2016 (om 15h05).

Soos per Andrea se ondergenoemde e-pos sal die projekspan binnekort antwoorde op jou skrywe deurstuur.

Moet asseblief nie huiwer om ons te kontak indien jy enige verdere inligting rakende die voorgestelde Tlisitseng Projek verlang nie

Vriendelike groete

Nicolene Venter
Publieke Deelname Konsultant
Selfoon: 083 377 9112

From: Andrea Gibb
Sent: 30 June 2016 11:20
To: Gys Goedhals <gysgoedhals@gmail.com>
Cc: Lynsey Rimbault <LynseyR@sivest.co.za>
Subject: RE: TLISITSENGSOLAR I

Dear Gys

Thank you, we have received your comments and will include them in our issues trail and respond to them in due course.

Kind Regards

Andrea Gibb (B.Sc. Landscape Architecture; B.Sc.(Hons) Environmental Management)
Environmental Practitioner and Visual Specialist
SiVEST Environmental Division



SiVEST is a Level 3 BBBEE Contributor

Direct +27 11 798 0638 **Tel** +27 11 798 0600 **fax** +27 11 803 7272 **cell** +27 72 587 6525
email andreag@sivest.co.za **website** www.sivest.co.za

Consulting Engineers - Project Managers - Environmental Consultants - Town and Regional Planners
Durban - Johannesburg - Pietermaritzburg - Richards Bay - Ladysmith - Cape Town - Harare (Zimbabwe)

From: Gys Goedhals [<mailto:gysgoedhals@gmail.com>]
Sent: Thursday, June 30, 2016 11:08 AM
To: Andrea Gibb <AndreaG@sivest.co.za>
Cc: Lynsey Rimbault <LynseyR@sivest.co.za>
Subject: TLISITSENGSOLAR I

**HALLO ANDREA.AANGEHEG BESWAAR TEEN VOORGESTELDE ONTWIKKELING VAN SONPLAAS SOOS
VOORGESTEL**
Gys Goedhals

Cell : 082 636 7902
Fax : 086 690 0184
Email : gysgoedhals@live.co.za
Email2 : gysgoedhals@gmail.com

Disclaimer

The information contained in this communication from the sender is confidential. It is intended solely for use by the recipient and others authorized to receive it. If you are not the recipient, you are hereby notified that any disclosure, copying, distribution or taking action in relation of the contents of this information is strictly prohibited and may be unlawful.

This email has been scanned for viruses and malware, and automatically archived by Mimecast SA (Pty) Ltd, an innovator in Software as a Service (SaaS) for business. Mimecast Unified Email Management ??? (UEM) offers email continuity, security, archiving and compliance with all current legislation. To find out more, [contact Mimecast](#).

Lynsey Rimbault

From: Nicolene Venter <nicolenev@zitholele.co.za>
Sent: 28 April 2016 15:45
To: gysgoedhals@gmail.com
Cc: Lynsey Rimbault; Rebecca Thomas
Subject: OIEs: Beogde Tlisitseng Fotovoltaïese en Sonkragaanlegte en BEs vir die Gepaardgaande 132kV Kraglyne
Attachments: Goedhals.pdf

Goeie middag Gys,

Soos belowe tydens my en Mariette Steynberg se besoek op 1 Desember 2015 en jou telefoniese versoek vanoggend, vind asseblief aangeheg die getekende brief en vorm.

Moet asseblief nie huiwer om my te kontak indien jy enige addisionele inligting rakende die voorgestelde projek verlang nie.

Vriendelike Groete,

Nicolene Venter [Cert. Public Relations]

Senior Public Participation Practitioner

Building 1, Maxwell Office Park, Magwa Crescent West, cnr Allandale Road & Maxwell Drive, Waterfall City, Midrand, RSA

T: +27 11 207 2060 **D:** +27 11 207 2077 **F:** +27 86 676 9950 **C:** +27 83 377 9112

E: nicolenev@zitholele.co.za **W:** www.zitholele.co.za



Please consider the environment before printing this e-mail!



