

# WINDOW SCHEDULE



-	MRA	01.08.2013	ISSUED FOR INFORMATION
REV	BY	DATE	DESCRIPTION

## GENERAL

- All glazing to comply with SANS 10400-N:2012 Edition 3
- All dimensions and levels to be checked on site and any discrepancies is to be referred to the author prior to any manufacturing.
- Frames to be manufactured and supplied by 'Swartland'
- Supplier to inspect all existing windows on site.
- All new windows to match existing windows in proportion and opening sections.
- Retain all existing aluminium and steel frame windows.

NOTE: All windows marked as 'R' and 'RB' to be replaced with PURPOSE MADE WOODEN FRAMES to suit as per schedule.

NOTE: CONTRACTOR TO CONFIRM QUANTITIES ON SITE

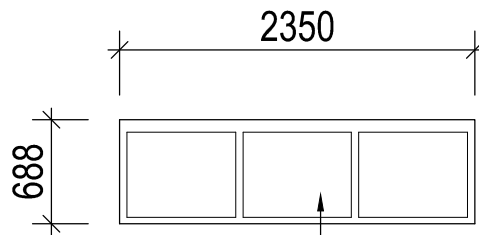

professional team	project description	revisions		SHEET 01						
 <p>ARCHITECT: MKHLON IYAVOO 22 Canford Park, 83 Anthony Road, Umgeni Park, Durban North, 4001 Tel: 031 552 7476   F: 031 966 4992 info@designscape.co.za   www.designscape.co.za</p>	REFURBISHMENT OF EXISTING ROOF FOR DRAMA STUDIES RITSON CAMPUS	<table border="1"> <tr> <td>REV</td> <td>-</td> </tr> <tr> <td>BY</td> <td>MRA</td> </tr> <tr> <td>DATE</td> <td>01.08.2013</td> </tr> </table>	REV		-	BY	MRA	DATE	01.08.2013	
REV	-									
BY	MRA									
DATE	01.08.2013									
client details	drawing description	DESCRIPTION								
 <p>PHYSICAL PLANING - D.U.T. Steve Biko Campus, Mansfield Road, Durban, 4023 tel. 031 373 2286 fax. 031 373 2896</p>	WINDOW SCHEDULE	project file								
		DATE: 19.07.2013	DRAWN BY MRA	SCALE 1:50						
		PROJECT No: 1009-11	DRAWING No: TD 03 - 1	REV. -						

# W-01



timber panels to be fitted into wooden frame

WINDOW TYPE	W1	QUANTITY	3
LOCATION	Roof along walkway		
FRAME	Purpose made wooden frame: 2350 x 688mm supplied by 'Swartland'		
PANEL	3x Timber panels to be fitted into wooden frame		
FINISH	Sand and dust then apply 2 coats of 'Plascon' Velvagro paint: White		
GENERAL	<ul style="list-style-type: none"> <li>- All dimensions and levels to be checked on site and any discrepancies is to be referred to the author prior to any manufacturing.</li> <li>- Supplier to inspect all existing windows on site.</li> <li>- All new windows to match existing windows in proportion and opening sections.</li> </ul>		

professional team  <small>ARCHITECT: MERELYN HAYWOOD 22 Conford Park, 63 Anthony Road, Urgents Plaza, Durban North, 4001 Tel: 031 262 7478   F: 031 263 4982 info@designscape.co.za   www.designscape.co.za</small>	project description REFURBISHMENT OF EXISTING ROOF FOR DRAMA STUDIES RITSON CAMPUS	revisions <table border="1"> <tr> <td>REV</td> <td>-</td> </tr> <tr> <td>BY</td> <td>MRA</td> </tr> <tr> <td>DATE</td> <td>01.08.2013</td> </tr> <tr> <td>DESCRIPTION</td> <td>ISSUED FOR INFORMATION</td> </tr> </table>	REV	-	BY	MRA	DATE	01.08.2013	DESCRIPTION	ISSUED FOR INFORMATION	SHEET 02				
REV	-														
BY	MRA														
DATE	01.08.2013														
DESCRIPTION	ISSUED FOR INFORMATION														
client details  <small>PHYSICAL PLANING – D.U.T. Steve Biko Campus, Mansfield Road, Durban, 4023 tel. 031 373 2286 fax. 031 373 2896</small>	drawing description WINDOW SCHEDULE	project file <table border="1"> <tr> <td>DATE:</td> <td>19.07.2013</td> <td>DRAWN BY:</td> <td>MRA</td> <td>SCALE:</td> <td>1:50</td> </tr> <tr> <td>PROJECT No:</td> <td>1009-11</td> <td>DRAWING No:</td> <td>TD 03 - 1</td> <td>REV.</td> <td>-</td> </tr> </table>	DATE:	19.07.2013	DRAWN BY:	MRA	SCALE:	1:50	PROJECT No:	1009-11	DRAWING No:	TD 03 - 1	REV.	-	
DATE:	19.07.2013	DRAWN BY:	MRA	SCALE:	1:50										
PROJECT No:	1009-11	DRAWING No:	TD 03 - 1	REV.	-										

# W-02

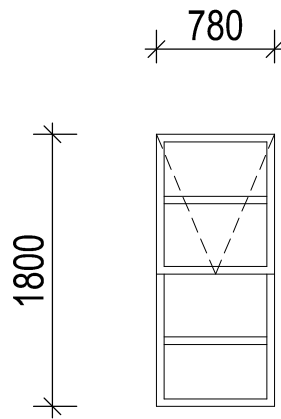



WINDOW TYPE	W2	QUANTITY	5
LOCATION	Upper Ground Floor: Dressing room & Stage		
FRAME	Purpose made wooden frame: 780 x 1800mm supplied by 'Swartland'		
GLAZING	4mm Clear Toughened Safety Glass puttied in with window putty as per N.B.R. NB: Use obscure glass at toilet.		
FINISH	Sand and dust then apply 2 coats of 'Plascon' Velvagro paint: White		
GENERAL	<ul style="list-style-type: none"> <li>- All glazing to comply with SANS 10400-N:2012 Edition 3</li> <li>- All dimensions and levels to be checked on site and any discrepancies is to be referred to the author prior to any manufacturing.</li> <li>- Supplier to inspect all existing windows on site.</li> <li>- All new windows to match existing windows in proportion and opening sections.</li> </ul>		

<b>DESIGNSCAPE</b> architects <small>ARCHITECT: MORGAN NYAVOO Reg No: 6628 22 Canford Park, 68 Anthony Road, Umgeni Park, Durban North, 4001 t: 031 7269 4410 f: 031 283 4092 info@designscape.co.za   www.designscape.co.za</small>	project description REFURBISHMENT OF EXISTING ROOF FOR DRAMA STUDIES RITSON CAMPUS	revisions <table border="1"> <tr> <td>REV</td> <td>-</td> </tr> <tr> <td>BY</td> <td>MRA</td> </tr> <tr> <td>DATE</td> <td>01.08.2013</td> </tr> <tr> <td>DESCRIPTION</td> <td>ISSUED FOR INFORMATION</td> </tr> </table>	REV	-	BY	MRA	DATE	01.08.2013	DESCRIPTION	ISSUED FOR INFORMATION	SHEET 03				
REV	-														
BY	MRA														
DATE	01.08.2013														
DESCRIPTION	ISSUED FOR INFORMATION														
<b>DUT DURBAN</b> UNIVERSITY OF TECHNOLOGY PHYSICAL PLANING – D.U.T. Steve Biko Campus, Mansfield Road, Durban, 4023 tel. 031 373 2286 fax. 031 373 2896	drawing description WINDOW SCHEDULE	project file <table border="1"> <tr> <td>DATE:</td> <td>DRAWN BY</td> <td>SCALE</td> </tr> <tr> <td>19.07.2013</td> <td>MRA</td> <td>1:50</td> </tr> <tr> <td>PROJECT No:</td> <td>DRAWING No:</td> <td>REV.</td> </tr> <tr> <td>1009-11</td> <td>TD 03 - 1</td> <td>-</td> </tr> </table>	DATE:	DRAWN BY	SCALE	19.07.2013	MRA	1:50	PROJECT No:	DRAWING No:	REV.	1009-11	TD 03 - 1	-	
DATE:	DRAWN BY	SCALE													
19.07.2013	MRA	1:50													
PROJECT No:	DRAWING No:	REV.													
1009-11	TD 03 - 1	-													

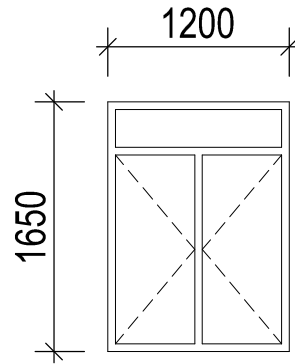
# W-03





WINDOW TYPE	W3	QUANTITY	7
LOCATION	Kitchen, Office 3, 5 & 6		
FRAME	Purpose made wooden frame: 1200 x 1650mm supplied by 'Swartland'		
GLAZING	4mm Clear Toughened Safety Glass puttied in with window putty as per N.B.R.		
FINISH	Sand and dust then apply 2 coats of 'Plascon' Velvagro paint: White		
GENERAL	<ul style="list-style-type: none"> <li>- All glazing to comply with SANS 10400-N:2012 Edition 3</li> <li>- All dimensions and levels to be checked on site and any discrepancies is to be referred to the author prior to any manufacturing.</li> <li>- Supplier to inspect all existing windows on site.</li> <li>- All new windows to match existing windows in proportion and opening sections.</li> </ul>		

professional team  <small>ARCHITECT: MGRLEN NYVVOO 22 Canford Park, 58 Anthony Road, Umgeni Park, Durban North, 4001 Reg No: 0828 t: 031 252 7476 f: 031 252 4952 info@designscape.co.za   www.designscape.co.za</small>	project description REFURBISHMENT OF EXISTING ROOF FOR DRAMA STUDIES RITSON CAMPUS	revisions <table border="1"> <tr> <td>REV</td> <td>-</td> </tr> <tr> <td>BY</td> <td>MRA</td> </tr> <tr> <td>DATE</td> <td>01.08.2013</td> </tr> <tr> <td>DESCRIPTION</td> <td>ISSUED FOR INFORMATION</td> </tr> </table>	REV	-	BY	MRA	DATE	01.08.2013	DESCRIPTION	ISSUED FOR INFORMATION	SHEET 04				
REV	-														
BY	MRA														
DATE	01.08.2013														
DESCRIPTION	ISSUED FOR INFORMATION														
client details  <small>PHYSICAL PLANING - D.U.T. Steve Biko Campus, Mansfield Road, Durban, 4023 tel. 031 373 2286 fax. 031 373 2896</small>	drawing description WINDOW SCHEDULE	project file <table border="1"> <tr> <td>DATE:</td> <td>19.07.2013</td> <td>DRAWN BY:</td> <td>MRA</td> <td>SCALE:</td> <td>1:50</td> </tr> <tr> <td>PROJECT No:</td> <td>1009-11</td> <td>DRAWING No:</td> <td>TD 01 - 20</td> <td>REV.:</td> <td>-</td> </tr> </table>	DATE:	19.07.2013	DRAWN BY:	MRA	SCALE:	1:50	PROJECT No:	1009-11	DRAWING No:	TD 01 - 20	REV.:	-	
DATE:	19.07.2013	DRAWN BY:	MRA	SCALE:	1:50										
PROJECT No:	1009-11	DRAWING No:	TD 01 - 20	REV.:	-										

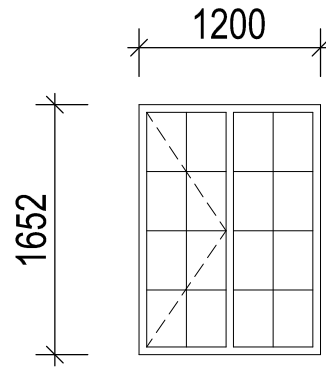
# W-04





WINDOW TYPE	W4	QUANTITY	3
LOCATION	Lower floor: Computer lab		
FRAME	Purpose made wooden frame: 1200 x 1652mm supplied by 'Swartland'		
GLAZING	4mm Clear Toughened Safety Glass puttied in with window putty as per N.B.R.		
FINISH	Sand and dust then apply 2 coats of 'Plascon' Velvago paint: White		
GENERAL	<ul style="list-style-type: none"> <li>- All glazing to comply with SANS 10400-N:2012 Edition 3</li> <li>- All dimensions and levels to be checked on site and any discrepancies is to be referred to the author prior to any manufacturing.</li> <li>- Supplier to inspect all existing windows on site.</li> <li>- All new windows to match existing windows in proportion and opening sections.</li> </ul>		

professional team  <small>ARCHITECT: MARLON NYAVO 22 Canford Park, 43 Anthony Road, Umgeni Park, Durban North, 4001 Reg No: 0528 t: 031 252 7476   f: 031 253 4982 info@designscape.co.za   www.designscape.co.za</small>	project description REFURBISHMENT OF EXISTING ROOF FOR DRAMA STUDIES RITSON CAMPUS	revisions <table border="1"> <tr> <td>REV</td> <td>-</td> </tr> <tr> <td>BY</td> <td>MRA</td> </tr> <tr> <td>DATE</td> <td>01.08.2013</td> </tr> <tr> <td>DESCRIPTION</td> <td>ISSUED FOR INFORMATION</td> </tr> </table>	REV	-	BY	MRA	DATE	01.08.2013	DESCRIPTION	ISSUED FOR INFORMATION	SHEET 05				
REV	-														
BY	MRA														
DATE	01.08.2013														
DESCRIPTION	ISSUED FOR INFORMATION														
client details  <small>PHYSICAL PLANING – D.U.T. Steve Biko Campus, Mansfield Road, Durban, 4023 tel. 031 373 2286 fax. 031 373 2896</small>	drawing description WINDOW SCHEDULE	project file <table border="1"> <tr> <td>DATE:</td> <td>19.07.2013</td> <td>DRAWN BY:</td> <td>MRA</td> <td>SCALE:</td> <td>1:50</td> </tr> <tr> <td>PROJECT No:</td> <td>1009-11</td> <td>DRAWING No:</td> <td>TD 03 - 1</td> <td>REV.:</td> <td>-</td> </tr> </table>	DATE:	19.07.2013	DRAWN BY:	MRA	SCALE:	1:50	PROJECT No:	1009-11	DRAWING No:	TD 03 - 1	REV.:	-	
DATE:	19.07.2013	DRAWN BY:	MRA	SCALE:	1:50										
PROJECT No:	1009-11	DRAWING No:	TD 03 - 1	REV.:	-										

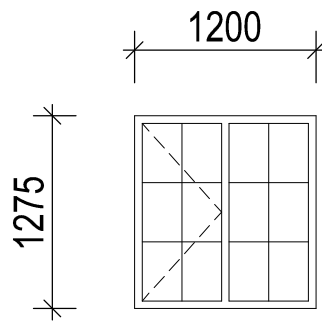
# W-05





WINDOW TYPE	W5	QUANTITY	1
LOCATION	Lower floor: Office		
FRAME	Purpose made wooden frame: 1200 x 1275mm supplied by 'Swartland'		
GLAZING	4mm Obscure Toughened Safety Glass puttied in with window putty as per N.B.R.		
FINISH	Sand and dust then apply 2 coats of 'Plascon' Velvagro paint: White		
GENERAL	<ul style="list-style-type: none"> <li>- All glazing to comply with SANS 10400-N:2012 Edition 3</li> <li>- All dimensions and levels to be checked on site and any discrepancies is to be referred to the author prior to any manufacturing.</li> <li>- Supplier to inspect all existing windows on site.</li> <li>- All new windows to match existing windows in proportion and opening sections.</li> </ul>		

professional team  <small>ARCHITECT: MRS. L. N. YAVOO 22 Canford Park, 53 Anthony Road, Umgeni Park, Durban North, 4061 Reg No: 6828 Tel: 031 282 7478   Fax: 031 284 4992 info@designscape.co.za   www.designscape.co.za</small>	project description REFURBISHMENT OF EXISTING ROOF FOR DRAMA STUDIES RITSON CAMPUS	revisions <table border="1"> <tr> <td>REV</td> <td>-</td> </tr> <tr> <td>BY</td> <td>MRA</td> </tr> <tr> <td>DATE</td> <td>01.08.2013</td> </tr> <tr> <td>DESCRIPTION</td> <td>ISSUED FOR INFORMATION</td> </tr> </table>	REV	-	BY	MRA	DATE	01.08.2013	DESCRIPTION	ISSUED FOR INFORMATION	SHEET 06			
REV	-													
BY	MRA													
DATE	01.08.2013													
DESCRIPTION	ISSUED FOR INFORMATION													
client details  PHYSICAL PLANING - D.U.T. <small>Steve Biko Campus, Mansfield Road, Durban, 4023 tel. 031 373 2286 fax. 031 373 2896</small>	drawing description WINDOW SCHEDULE	project file <table border="1"> <tr> <td>DATE:</td> <td>19.07.2013</td> <td>DRAWN BY:</td> <td>MRA</td> <td>SCALE:</td> <td>1:50</td> </tr> <tr> <td>PROJECT No:</td> <td>1009-11</td> <td>DRAWING No:</td> <td>TD 03 - 1</td> <td>REV.</td> <td>-</td> </tr> </table>	DATE:	19.07.2013	DRAWN BY:	MRA	SCALE:	1:50	PROJECT No:	1009-11	DRAWING No:	TD 03 - 1	REV.	-
DATE:	19.07.2013	DRAWN BY:	MRA	SCALE:	1:50									
PROJECT No:	1009-11	DRAWING No:	TD 03 - 1	REV.	-									

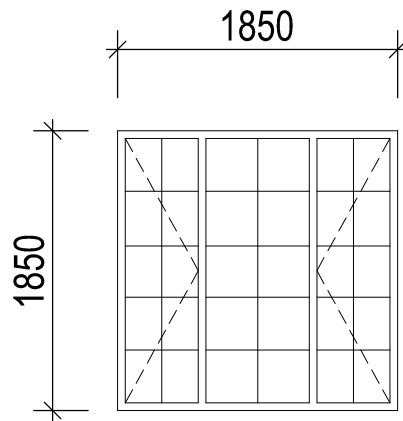
# W-06





WINDOW TYPE	W6	QUANTITY	2
LOCATION	UPPER FLOOR: CLASSROOM 1		
FRAME	Purpose made wooden frame: 2250 x 1652mm supplied by 'Swartland'		
GLAZING	4mm Clear Toughened Safety Glass puttied in with window putty as per N.B.R.		
FINISH	Sand and dust then apply 2 coats of 'Plascon' Velvagro paint: White		
GENERAL	<ul style="list-style-type: none"> <li>- All glazing to comply with SANS 10400-N:2012 Edition 3</li> <li>- All dimensions and levels to be checked on site and any discrepancies is to be referred to the author prior to any manufacturing.</li> <li>- Supplier to inspect all existing windows on site.</li> <li>- All new windows to match existing windows in proportion and opening sections.</li> </ul>		

<b>professional team</b>  <small>ARCHITECT: MERRICK MVAUO 22 Canford Park, 63 Anthony Road, Umgeni Park, Durban North, 4091 Tel: 031 262 4776   F: 031 263 4952 info@designscape.co.za   www.designscape.co.za</small>	<b>project description</b> REFURBISHMENT OF EXISTING ROOF FOR DRAMA STUDIES RITSON CAMPUS	<b>revisions</b> <table border="1"> <tr> <td>REV</td> <td>-</td> </tr> <tr> <td>BY</td> <td>MRA</td> </tr> <tr> <td>DATE</td> <td>01.08.2013</td> </tr> <tr> <td>DESCRIPTION</td> <td>ISSUED FOR INFORMATION</td> </tr> </table>	REV	-	BY	MRA	DATE	01.08.2013	DESCRIPTION	ISSUED FOR INFORMATION	<b>SHEET 07</b>			
REV	-													
BY	MRA													
DATE	01.08.2013													
DESCRIPTION	ISSUED FOR INFORMATION													
<b>client details</b>  PHYSICAL PLANING - D.U.T. Steve Biko Campus, Mansfield Road, Durban, 4023 tel. 031 373 2286 fax. 031 373 2896	<b>drawing description</b> WINDOW SCHEDULE	<b>project file</b> <table border="1"> <tr> <td>DATE:</td> <td>19.07.2013</td> <td>DRAWN BY:</td> <td>MRA</td> <td>SCALE:</td> <td>1:50</td> </tr> <tr> <td>PROJECT No:</td> <td>1009-11</td> <td>DRAWING No:</td> <td>TD 03 - 1</td> <td>REV.:</td> <td>-</td> </tr> </table>	DATE:	19.07.2013	DRAWN BY:	MRA	SCALE:	1:50	PROJECT No:	1009-11	DRAWING No:	TD 03 - 1	REV.:	-
DATE:	19.07.2013	DRAWN BY:	MRA	SCALE:	1:50									
PROJECT No:	1009-11	DRAWING No:	TD 03 - 1	REV.:	-									

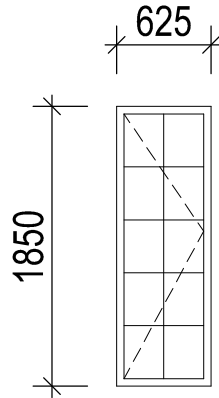
# W-07



WINDOW TYPE	W7	QUANTITY	1
LOCATION	Upper Ground Floor: Classroom 1		
FRAME	Purpose made wooden frame: 625 x 1850mm supplied by 'Swartland'		
GLAZING	4mm Clear Toughened Safety Glass puttied in with window putty as per N.B.R. &		
FINISH	Sand and dust then apply 2 coats of 'Plascon' Velvaglo paint: White		
GENERAL	<ul style="list-style-type: none"> <li>- All glazing to comply with SANS 10400-N:2012 Edition 3</li> <li>- All dimensions and levels to be checked on site and any discrepancies is to be referred to the author prior to any manufacturing.</li> <li>- Supplier to inspect all existing windows on site.</li> <li>- All new windows to match existing windows in proportion and opening sections.</li> </ul>		



<p>professional team</p>  <p>ARCHITECT: MARLON HYWOOD Reg No: 0828 22 Canford Park, 58 Anthony Road, Umegeni Park, Durban North, 4001 t: 031 252 7476   f: 031 063 4952 info@designscape.co.za   www.designscape.co.za</p>	<p>project description</p> <p>REFURBISHMENT OF EXISTING ROOF FOR DRAMA STUDIES RITSON CAMPUS</p>	<p>revisions</p> <table border="1"> <tr> <td>REV</td> <td>-</td> </tr> <tr> <td>BY</td> <td>MRA</td> </tr> <tr> <td>DATE</td> <td>01.08.2013</td> </tr> <tr> <td>DESCRIPTION</td> <td>ISSUED FOR INFORMATION</td> </tr> </table> <p style="text-align: right;">SHEET 08</p>	REV	-	BY	MRA	DATE	01.08.2013	DESCRIPTION	ISSUED FOR INFORMATION				
REV	-													
BY	MRA													
DATE	01.08.2013													
DESCRIPTION	ISSUED FOR INFORMATION													
<p>client details</p>  <p>PHYSICAL PLANING - D.U.T. Steve Biko Campus, Mansfield Road, Durban, 4023 tel. 031 373 2286 fax. 031 373 2896</p>	<p>drawing description</p> <p>WINDOW SCHEDULE</p>	<p>project file</p> <table border="1"> <tr> <td>DATE:</td> <td>DRAWN BY</td> <td>SCALE</td> </tr> <tr> <td>19.07.2013</td> <td>MRA</td> <td>1:50</td> </tr> <tr> <td>PROJECT No:</td> <td>DRAWING No:</td> <td>REV.</td> </tr> <tr> <td>1009-11</td> <td>TD 03 - 1</td> <td>-</td> </tr> </table>	DATE:	DRAWN BY	SCALE	19.07.2013	MRA	1:50	PROJECT No:	DRAWING No:	REV.	1009-11	TD 03 - 1	-
DATE:	DRAWN BY	SCALE												
19.07.2013	MRA	1:50												
PROJECT No:	DRAWING No:	REV.												
1009-11	TD 03 - 1	-												

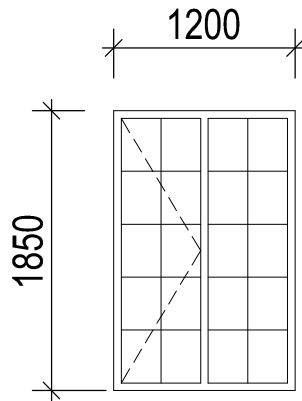

# W-08





WINDOW TYPE	W8	QUANTITY	3
LOCATION	Upper Ground Floor: Classroom 1, Store 129 & Printing and props store		
FRAME	Purpose made wooden frame: 1200 x 1850mm supplied by 'Swartland'		
GLAZING	4mm Clear Toughened Safety Glass puttied in with window putty as per N.B.R.		
FINISH	Sand and dust then apply 2 coats of 'Plascon' Velvagro paint: White		
GENERAL	<ul style="list-style-type: none"> <li>- All glazing to comply with SANS 10400-N:2012 Edition 3</li> <li>- All dimensions and levels to be checked on site and any discrepancies is to be referred to the author prior to any manufacturing.</li> <li>- Supplier to inspect all existing windows on site.</li> <li>- All new windows to match existing windows in proportion and opening sections.</li> </ul>		

<b>professional team</b>  <small>ARCHITECT: MERLON IYK'00 22 Carlford Park, 53 Anthony Road, Umgeni Park, Durban North, 4051 Tel: 031 263 7470   F: 031 263 4952 info@designscape.co.za   www.designscape.co.za</small>	<b>project description</b> REFURBISHMENT OF EXISTING ROOF FOR DRAMA STUDIES RITSON CAMPUS	<b>revisions</b> <table border="1"> <tr> <td>REV</td> <td>-</td> </tr> <tr> <td>BY</td> <td>MRA</td> </tr> <tr> <td>DATE</td> <td>01.08.2013</td> </tr> <tr> <td>DESCRIPTION</td> <td>ISSUED FOR INFORMATION</td> </tr> </table>	REV	-	BY	MRA	DATE	01.08.2013	DESCRIPTION	ISSUED FOR INFORMATION	<b>SHEET 09</b>				
REV	-														
BY	MRA														
DATE	01.08.2013														
DESCRIPTION	ISSUED FOR INFORMATION														
<b>client details</b>  PHYSICAL PLANNING - D.U.T. Steve Biko Campus, Mansfield Road, Durban, 4023 tel. 031 373 2286 fax. 031 373 2896	<b>drawing description</b> WINDOW SCHEDULE	<b>project file</b> <table border="1"> <tr> <td>DATE:</td> <td>DRAWN BY</td> <td>SCALE</td> </tr> <tr> <td>19.07.2013</td> <td>MRA</td> <td>1:50</td> </tr> <tr> <td>PROJECT No:</td> <td>DRAWING No:</td> <td>REV.</td> </tr> <tr> <td>1009-11</td> <td>TD 03 - 1</td> <td>-</td> </tr> </table>	DATE:	DRAWN BY	SCALE	19.07.2013	MRA	1:50	PROJECT No:	DRAWING No:	REV.	1009-11	TD 03 - 1	-	
DATE:	DRAWN BY	SCALE													
19.07.2013	MRA	1:50													
PROJECT No:	DRAWING No:	REV.													
1009-11	TD 03 - 1	-													

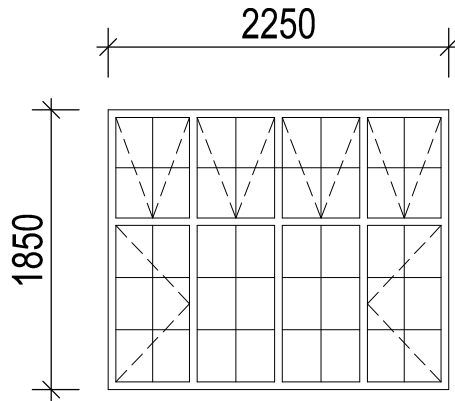
# W-09



WINDOW TYPE	W9	QUANTITY	1
LOCATION	Upper Ground Floor: Male / Female Ablutions		
FRAME	Purpose made wooden frame: 2250 x 1850mm supplied by 'Swartland'		
GLAZING	4mm Obscure Toughened Safety Glass puttied in with window putty as per N.B.R.		
FINISH	Sand and dust then apply 2 coats of 'Plascon' Velvagro paint: White		
GENERAL	<ul style="list-style-type: none"> <li>- All glazing to comply with SANS 10400-N:2012 Edition 3</li> <li>- All dimensions and levels to be checked on site and any discrepancies is to be referred to the author prior to any manufacturing.</li> <li>- Supplier to inspect all existing windows on site.</li> <li>- All new windows to match existing windows in proportion and opening sections.</li> </ul>		

<b>professional team</b>  <small>ARCHITECT: MIBELON NYAVOO Reg No: 6028</small>	<b>project description</b> REFURBISHMENT OF EXISTING ROOF FOR DRAMA STUDIES RITSON CAMPUS	<b>revisions</b> <table border="1"> <tr> <td>REV</td> <td>-</td> </tr> <tr> <td>BY</td> <td>MRA</td> </tr> <tr> <td>DATE</td> <td>01.08.2013</td> </tr> <tr> <td>DESCRIPTION</td> <td>ISSUED FOR INFORMATION</td> </tr> </table>	REV	-	BY	MRA	DATE	01.08.2013	DESCRIPTION	ISSUED FOR INFORMATION	<b>SHEET 10</b>			
REV	-													
BY	MRA													
DATE	01.08.2013													
DESCRIPTION	ISSUED FOR INFORMATION													
<b>client details</b>  PHYSICAL PLANING - D.U.T. <small>Steve Biko Campus, Mansfield Road, Durban, 4023</small>	<b>drawing description</b> WINDOW SCHEDULE	<b>project file</b> <table border="1"> <tr> <td>DATE:</td> <td>19.07.2013</td> <td>DRAWN BY:</td> <td>MRA</td> <td>SCALE:</td> <td>1:50</td> </tr> <tr> <td>PROJECT No:</td> <td>1009-11</td> <td>DRAWING No:</td> <td>TD 03 - 1</td> <td>REV.:</td> <td>-</td> </tr> </table>	DATE:	19.07.2013	DRAWN BY:	MRA	SCALE:	1:50	PROJECT No:	1009-11	DRAWING No:	TD 03 - 1	REV.:	-
DATE:	19.07.2013	DRAWN BY:	MRA	SCALE:	1:50									
PROJECT No:	1009-11	DRAWING No:	TD 03 - 1	REV.:	-									

# W-10

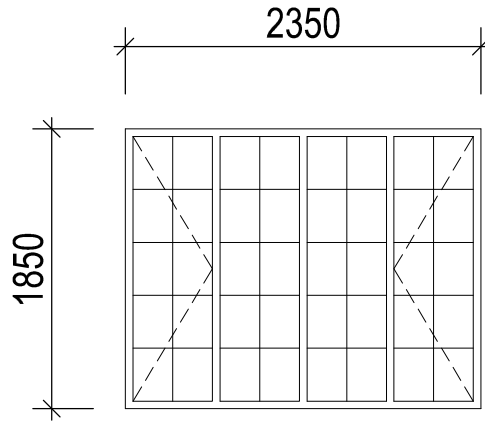

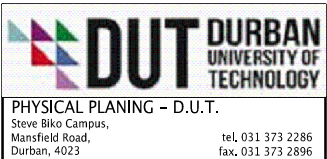

WINDOW TYPE	W10	QUANTITY	1
LOCATION	Upper Ground Floor: Printing room & Props Store		
FRAME	Purpose made wooden frame: 2350 x 1850mm supplied by 'Swartland'		
GLAZING	4mm Clear Toughened Safety Glass puttied in with window putty as per N.B.R.		
FINISH	Sand and dust then apply 2 coats of 'Plascon' Velvago paint: White		
GENERAL	<ul style="list-style-type: none"> <li>- All glazing to comply with SANS 10400-N:2012 Edition 3</li> <li>- All dimensions and levels to be checked on site and any discrepancies is to be referred to the author prior to any manufacturing.</li> <li>- Supplier to inspect all existing windows on site.</li> <li>- All new windows to match existing windows in proportion and opening sections.</li> </ul>		

<b>professional team</b>  <small>ARCHITECT: MERLON HYWOOD 22 Conford Park, 69 Anthony Road, Urgent Park, Durban North, 4051 Tel: 031 553 4478   F: 031 263 4952 info@designscape.co.za   www.designscape.co.za</small>	<b>project description</b> REFURBISHMENT OF EXISTING ROOF FOR DRAMA STUDIES RITSON CAMPUS	<b>revisions</b> <table border="1"> <tr> <td>REV</td> <td>-</td> </tr> <tr> <td>BY</td> <td>MRA</td> </tr> <tr> <td>DATE</td> <td>01.08.2013</td> </tr> <tr> <td>DESCRIPTION</td> <td>ISSUED FOR INFORMATION</td> </tr> </table>	REV	-	BY	MRA	DATE	01.08.2013	DESCRIPTION	ISSUED FOR INFORMATION	<b>SHEET 11</b>			
REV	-													
BY	MRA													
DATE	01.08.2013													
DESCRIPTION	ISSUED FOR INFORMATION													
<b>client details</b>  <small>PHYSICAL PLANING - D.U.T. Steve Biko Campus, Mansfield Road, Durban, 4023 tel. 031 373 2286 fax. 031 373 2896</small>	<b>drawing description</b> WINDOW SCHEDULE	<b>project file</b> <table border="1"> <tr> <td>DATE:</td> <td>DRAWN BY</td> <td>SCALE</td> </tr> <tr> <td>19.07.2013</td> <td>MRA</td> <td>1:50</td> </tr> <tr> <td>PROJECT No:</td> <td>DRAWING No:</td> <td>REV.</td> </tr> <tr> <td>1009-11</td> <td>TD 03 - 1</td> <td>-</td> </tr> </table>	DATE:	DRAWN BY	SCALE	19.07.2013	MRA	1:50	PROJECT No:	DRAWING No:	REV.	1009-11	TD 03 - 1	-
DATE:	DRAWN BY	SCALE												
19.07.2013	MRA	1:50												
PROJECT No:	DRAWING No:	REV.												
1009-11	TD 03 - 1	-												

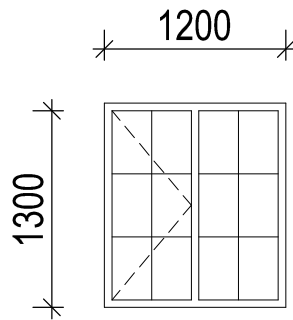
# W-11



WINDOW TYPE	W11	QUANTITY	2
LOCATION	Upper Ground Floor: Store 127 & Office 8		
FRAME	Purpose made wooden frame: 1200 x 1300mm supplied by 'Swartland'		
GLAZING	4mm Clear Toughened Safety Glass puttied in with window putty as per N.B.R.		
FINISH	Sand and dust then apply 2 coats of 'Plascon' Velvago paint: White		
GENERAL	<ul style="list-style-type: none"> <li>- All glazing to comply with SANS 10400-N:2012 Edition 3</li> <li>- All dimensions and levels to be checked on site and any discrepancies is to be referred to the author prior to any manufacturing.</li> <li>- Supplier to inspect all existing windows on site.</li> <li>- All new windows to match existing windows in proportion and opening sections.</li> </ul>		

professional team  <small>ARCHITECT: MARLON NYAVOO Reg No: 6528 22 Canford Park, 68 Anthony Road, Umhlanga Park, Durban North, 4051 T: 031 263 4476   F: 031 263 4992 info@dscape.co.za   www.dscape.co.za</small>	project description REFURBISHMENT OF EXISTING ROOF FOR DRAMA STUDIES RITSON CAMPUS	revisions <table border="1"> <tr> <td>REV</td> <td>-</td> </tr> <tr> <td>BY</td> <td>MRA</td> </tr> <tr> <td>DATE</td> <td>01.08.2013</td> </tr> <tr> <td>DESCRIPTION</td> <td>ISSUED FOR INFORMATION</td> </tr> </table>	REV	-	BY	MRA	DATE	01.08.2013	DESCRIPTION	ISSUED FOR INFORMATION	SHEET 12				
REV	-														
BY	MRA														
DATE	01.08.2013														
DESCRIPTION	ISSUED FOR INFORMATION														
client details  <small>PHYSICAL PLANING – D.U.T. Steve Biko Campus, Mansfield Road, Durban, 4023 tel. 031 373 2286 fax. 031 373 2896</small>	drawing description WINDOW SCHEDULE	project file <table border="1"> <tr> <td>DATE:</td> <td>DRAWN BY</td> <td>SCALE</td> </tr> <tr> <td>19.07.2013</td> <td>MRA</td> <td>1:50</td> </tr> <tr> <td>PROJECT No:</td> <td>DRAWING No:</td> <td>REV.</td> </tr> <tr> <td>1009-11</td> <td>TD 03 - 1</td> <td>-</td> </tr> </table>	DATE:	DRAWN BY	SCALE	19.07.2013	MRA	1:50	PROJECT No:	DRAWING No:	REV.	1009-11	TD 03 - 1	-	
DATE:	DRAWN BY	SCALE													
19.07.2013	MRA	1:50													
PROJECT No:	DRAWING No:	REV.													
1009-11	TD 03 - 1	-													

# W-12

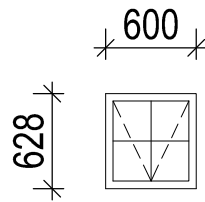

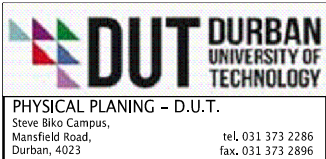

WINDOW TYPE	W12	QUANTITY	6
LOCATION	Upper Ground Floor: Male & Female ablution		
FRAME	Purpose made wooden frame: 600 x 628mm supplied by 'Swartland'		
GLAZING	4mm Obscure Toughened Safety Glass puttied in with window putty as per N.B.R.		
FINISH	Sand and dust then apply 2 coats of 'Plascon' Velvagro paint: White		
GENERAL	<ul style="list-style-type: none"> <li>- All glazing to comply with SANS 10400-N:2012 Edition 3</li> <li>- All dimensions and levels to be checked on site and any discrepancies is to be referred to the author prior to any manufacturing.</li> <li>- Supplier to inspect all existing windows on site.</li> <li>- All new windows to match existing windows in proportion and opening sections.</li> </ul>		

professional team  <small>ARCHITECT: MQRLEN NYAVOO Reg No: 6528</small>	project description REFURBISHMENT OF EXISTING ROOF FOR DRAMA STUDIES RITSON CAMPUS	revisions <table border="1"> <tr> <td>REV</td> <td>-</td> </tr> <tr> <td>BY</td> <td>MRA</td> </tr> <tr> <td>DATE</td> <td>01.08.2013</td> </tr> <tr> <td>DESCRIPTION</td> <td>ISSUED FOR INFORMATION</td> </tr> </table>	REV	-	BY	MRA	DATE	01.08.2013	DESCRIPTION	ISSUED FOR INFORMATION	<b>SHEET 13</b>			
REV	-													
BY	MRA													
DATE	01.08.2013													
DESCRIPTION	ISSUED FOR INFORMATION													
client details  <small>PHYSICAL PLANING – D.U.T. Steve Biko Campus, Mansfield Road, Durban, 4023</small>	drawing description WINDOW SCHEDULE	project file <table border="1"> <tr> <td>DATE:</td> <td>DRAWN BY:</td> <td>SCALE</td> </tr> <tr> <td>19.07.2013</td> <td>MRA</td> <td>1:50</td> </tr> <tr> <td>PROJECT No:</td> <td>DRAWING No:</td> <td>REV.</td> </tr> <tr> <td>1009-11</td> <td>TD 03 - 1</td> <td>-</td> </tr> </table>	DATE:	DRAWN BY:	SCALE	19.07.2013	MRA	1:50	PROJECT No:	DRAWING No:	REV.	1009-11	TD 03 - 1	-
DATE:	DRAWN BY:	SCALE												
19.07.2013	MRA	1:50												
PROJECT No:	DRAWING No:	REV.												
1009-11	TD 03 - 1	-												

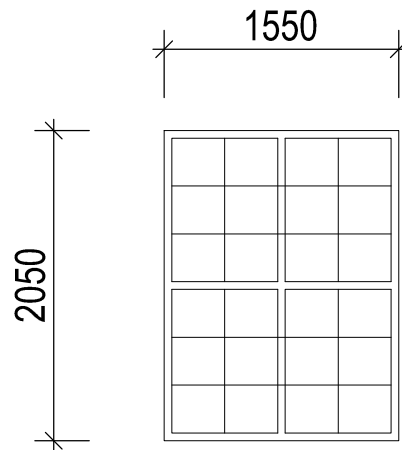
# W-13





WINDOW TYPE	W13	QUANTITY	2
LOCATION	FIRST FLOOR: STAIRCASE 1 & STAIRCASE 2		
FRAME	Repair wooden frame: 2250 x 1652mm supplied by 'Swartland'		
GLAZING	4mm Clear Toughened Safety Glass puttied in with window putty as per N.B.R.		
FINISH	Sand and dust then apply 2 coats of 'Plascon' Velvagro paint: White		
GENERAL	<ul style="list-style-type: none"> <li>- All glazing to comply with SANS 10400-N:2012 Edition 3</li> <li>- All dimensions and levels to be checked on site and any discrepancies is to be referred to the author prior to any manufacturing.</li> <li>- Supplier to inspect all existing windows on site.</li> <li>- All new windows to match existing windows in proportion and opening sections.</li> </ul>		

professional team  <small>ARCHITECT: MARLON NYAVO Reg. No: 0508 22 Conford Park, 58 Anthony Road, Umhlanga Estate, Durban North, 4001 T: 031 552 7478   F: 031 653 4992 info@designscape.co.za   www.designscape.co.za</small>	project description REFURBISHMENT OF EXISTING ROOF FOR DRAMA STUDIES RITSON CAMPUS	revisions <table border="1"> <tr> <td>REV</td> <td>-</td> </tr> <tr> <td>BY</td> <td>MRA</td> </tr> <tr> <td>DATE</td> <td>01.08.2013</td> </tr> <tr> <td>DESCRIPTION</td> <td>ISSUED FOR INFORMATION</td> </tr> </table>	REV	-	BY	MRA	DATE	01.08.2013	DESCRIPTION	ISSUED FOR INFORMATION	SHEET 14			
REV	-													
BY	MRA													
DATE	01.08.2013													
DESCRIPTION	ISSUED FOR INFORMATION													
client details  <small>PHYSICAL PLANING – D.U.T. Steve Biko Campus, Mansfield Road, Durban, 4023 tel. 031 373 2286 fax. 031 373 2896</small>	drawing description WINDOW SCHEDULE	project file <table border="1"> <tr> <td>DATE:</td> <td>DRAWN BY</td> <td>SCALE</td> </tr> <tr> <td>19.07.2013</td> <td>MRA</td> <td>1:50</td> </tr> <tr> <td>PROJECT No:</td> <td>DRAWING No:</td> <td>REV.</td> </tr> <tr> <td>1009-11</td> <td>TD 03 - 1</td> <td>-</td> </tr> </table>	DATE:	DRAWN BY	SCALE	19.07.2013	MRA	1:50	PROJECT No:	DRAWING No:	REV.	1009-11	TD 03 - 1	-
DATE:	DRAWN BY	SCALE												
19.07.2013	MRA	1:50												
PROJECT No:	DRAWING No:	REV.												
1009-11	TD 03 - 1	-												

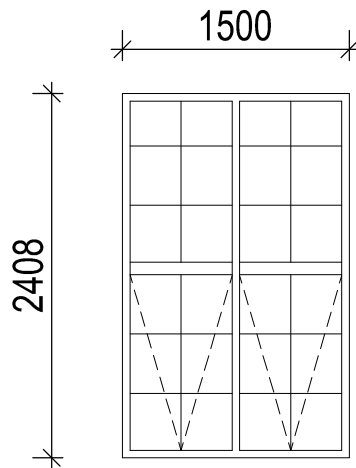
# W-14



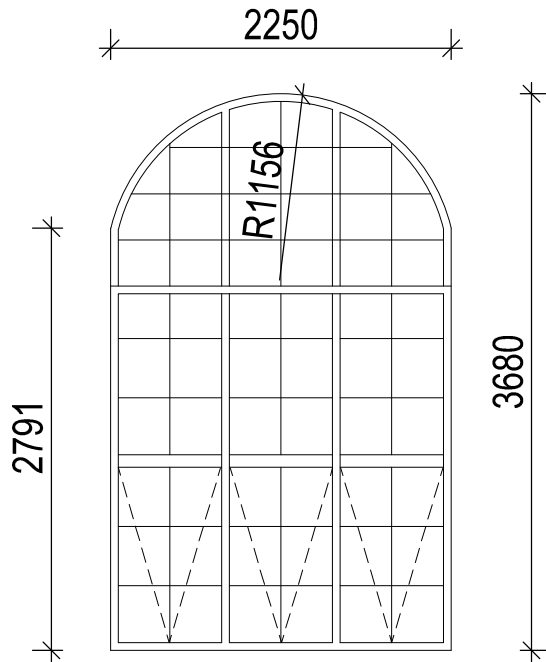

WINDOW TYPE	W14	QUANTITY	2
LOCATION	First Floor: Lecture room 1 & Rehearsal room 215		
FRAME	Purpose made wooden frame: 1500 x 2408mm supplied by 'Swartland'		
GLAZING	4mm Clear Toughened Safety Glass puttied in with window putty as per N.B.R.		
FINISH	Sand and dust then apply 2 coats of 'Plascon' Velvagio paint: White		
GENERAL	<ul style="list-style-type: none"> <li>- All glazing to comply with SANS 10400-N:2012 Edition 3</li> <li>- All dimensions and levels to be checked on site and any discrepancies is to be referred to the author prior to any manufacturing.</li> <li>- Supplier to inspect all existing windows on site.</li> <li>- All new windows to match existing windows in proportion and opening sections.</li> </ul>		

professional team  <small>ARCHITECT: MURILYN NYAVOJO 22 Canford Park, 53 Anthony Road, Umgeni Park, Durban North, 4001 Reg No: 2528 t: 031 252 7470 f: 031 252 4092 info@descape.co.za   www.descape.co.za</small>	project description REFURBISHMENT OF EXISTING ROOF FOR DRAMA STUDIES RITSON CAMPUS	revisions <table border="1"> <tr> <td>REV</td> <td>-</td> </tr> <tr> <td>BY</td> <td>MRA</td> </tr> <tr> <td>DATE</td> <td>01.08.2013</td> </tr> <tr> <td>DESCRIPTION</td> <td>ISSUED FOR INFORMATION</td> </tr> </table>	REV	-	BY	MRA	DATE	01.08.2013	DESCRIPTION	ISSUED FOR INFORMATION	SHEET 15				
REV	-														
BY	MRA														
DATE	01.08.2013														
DESCRIPTION	ISSUED FOR INFORMATION														
client details  <small>PHYSICAL PLANING - D.U.T. Steve Biko Campus, Mansfield Road, Durban, 4023 tel. 031 373 2286 fax. 031 373 2896</small>	drawing description WINDOW SCHEDULE	project file <table border="1"> <tr> <td>DATE:</td> <td>DRAWN BY</td> <td>SCALE</td> </tr> <tr> <td>19.07.2013</td> <td>MRA</td> <td>1:50</td> </tr> <tr> <td>PROJECT No:</td> <td>DRAWING No:</td> <td>REV.</td> </tr> <tr> <td>1009-11</td> <td>TD 03 - 1</td> <td>-</td> </tr> </table>	DATE:	DRAWN BY	SCALE	19.07.2013	MRA	1:50	PROJECT No:	DRAWING No:	REV.	1009-11	TD 03 - 1	-	
DATE:	DRAWN BY	SCALE													
19.07.2013	MRA	1:50													
PROJECT No:	DRAWING No:	REV.													
1009-11	TD 03 - 1	-													



# W-15

WINDOW TYPE	W15	QUANTITY	4
LOCATION	First Floor: Lecture room 1 & 2 and Rehearsal room 215		
FRAME	Purpose made wooden frame: 2250 x 3680mm supplied by 'Swartland'		
GLAZING	4mm Clear Toughened Safety Glass puttied in with window putty as per N.B.R.		
FINISH	Sand and dust then apply 2 coats of 'Plascon' Velvagro paint: White		
GENERAL	<ul style="list-style-type: none"> <li>- All glazing to comply with SANS 10400-N:2012 Edition 3</li> <li>- All dimensions and levels to be checked on site and any discrepancies is to be referred to the author prior to any manufacturing.</li> <li>- Supplier to inspect all existing windows on site.</li> <li>- All new windows to match existing windows in proportion and opening sections.</li> </ul>		

professional team  <small>ARCHITECT: MERLON NYAVOZI 22 Canford Park, 59 Anthony Road, Umganga Park, Durban North, 4001 Tel: 031 662 1111 info@designscape.co.za   www.designscape.co.za</small>	project description REFURBISHMENT OF EXISTING ROOF FOR DRAMA STUDIES RITSON CAMPUS	revisions <table border="1"> <tr> <td>REV</td> <td>-</td> </tr> <tr> <td>BY</td> <td>MRA</td> </tr> <tr> <td>DATE</td> <td>01.08.2013</td> </tr> <tr> <td>DESCRIPTION</td> <td>ISSUED FOR INFORMATION</td> </tr> </table>	REV	-	BY	MRA	DATE	01.08.2013	DESCRIPTION	ISSUED FOR INFORMATION	SHEET 16			
REV	-													
BY	MRA													
DATE	01.08.2013													
DESCRIPTION	ISSUED FOR INFORMATION													
client details  <small>PHYSICAL PLANING – D.U.T. Steve Biko Campus, Mansfield Road, Durban, 4023 tel. 031 373 2286 fax. 031 373 2896</small>	drawing description WINDOW SCHEDULE	project file <table border="1"> <tr> <td>DATE:</td> <td>DRAWN BY</td> <td>SCALE</td> </tr> <tr> <td>19.07.2013</td> <td>MRA</td> <td>1:50</td> </tr> <tr> <td>PROJECT No:</td> <td>DRAWING No:</td> <td>REV.</td> </tr> <tr> <td>1009-11</td> <td>TD 03 - 1</td> <td>-</td> </tr> </table>	DATE:	DRAWN BY	SCALE	19.07.2013	MRA	1:50	PROJECT No:	DRAWING No:	REV.	1009-11	TD 03 - 1	-
DATE:	DRAWN BY	SCALE												
19.07.2013	MRA	1:50												
PROJECT No:	DRAWING No:	REV.												
1009-11	TD 03 - 1	-												



# W-16

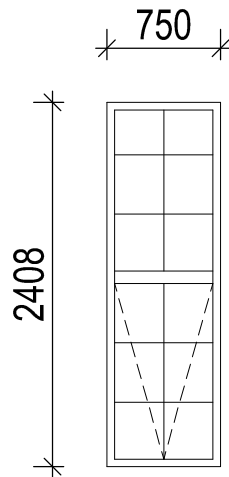

WINDOW TYPE	W16	QUANTITY	6
LOCATION	First Floor: Lecture room 1 & 2 and Rehearsal room 215		
FRAME	Purpose made wooden frame: 750 x 2408mm supplied by 'Swartland'		
GLAZING	4mm Clear Toughened Safety Glass puttied in with window putty as per N.B.R.		
FINISH	Sand and dust then apply 2 coats of 'Plascon' Velvago paint: White		
GENERAL	<ul style="list-style-type: none"> <li>- All glazing to comply with SANS 10400-N:2012 Edition 3</li> <li>- All dimensions and levels to be checked on site and any discrepancies is to be referred to the author prior to any manufacturing.</li> <li>- Supplier to inspect all existing windows on site.</li> <li>- All new windows to match existing windows in proportion and opening sections.</li> </ul>		

professional team



client details

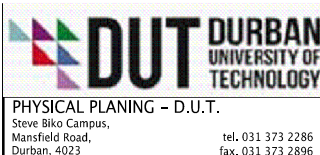

project description

REFURBISHMENT OF EXISTING ROOF FOR DRAMA STUDIES :  
RITSON CAMPUS

drawing description

WINDOW SCHEDULE

revisions

REV	-
BY	MRA
DATE	01.08.2013
DESCRIPTION	ISSUED FOR INFORMATION

project file



DATE:	DRAWN BY	SCALE
19.07.2013	MRA	1:50
PROJECT No:	DRAWING No:	REV.
1009-11	TD 03 - 1	-

SHEET 17

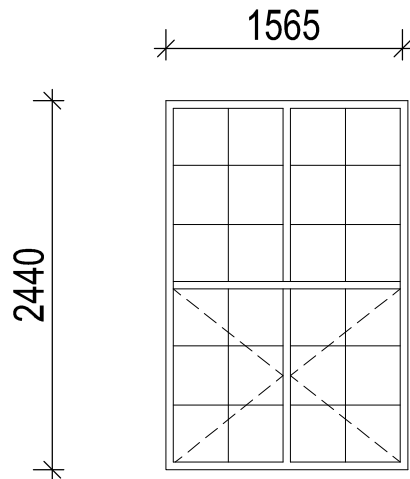
# W-17



WINDOW TYPE	W17	QUANTITY	2
LOCATION	First floor: Corridor 3 & Corridor 4		
FRAME	Repair existing wooden frame: 1565x 2440mm		
GLAZING	4mm Clear Toughened Safety Glass puttied in with window putty as per N.B.R.		
FINISH	Sand and dust then apply 2 coats of 'Plascon' Velvaglo paint: White		
GENERAL	<ul style="list-style-type: none"> <li>- All glazing to comply with SANS 10400-N:2012 Edition 3</li> <li>- All dimensions and levels to be checked on site and any discrepancies is to be referred to the author prior to any manufacturing.</li> <li>- Supplier to inspect all existing windows on site.</li> <li>- All new windows to match existing windows in proportion and opening sections.</li> </ul>		

professional team  <small>ARCHITECT: MARLON HYWOOD Reg No: 6826 22 Canford Park, 58 Anthony Road, Umgeni Park, Durban North, 4091 t: 031 252 7476   f: 031 263 4982 info@designscape.co.za   www.designscape.co.za</small>	project description REFURBISHMENT OF EXISTING ROOF FOR DRAMA STUDIES RITSON CAMPUS	revisions <table border="1"> <tr> <td>REV</td> <td>-</td> </tr> <tr> <td>BY</td> <td>MRA</td> </tr> <tr> <td>DATE</td> <td>01.08.2013</td> </tr> <tr> <td>DESCRIPTION</td> <td>ISSUED FOR INFORMATION</td> </tr> </table>	REV	-	BY	MRA	DATE	01.08.2013	DESCRIPTION	ISSUED FOR INFORMATION	<b>SHEET 18</b>			
REV	-													
BY	MRA													
DATE	01.08.2013													
DESCRIPTION	ISSUED FOR INFORMATION													
client details  <small>PHYSICAL PLANING - D.U.T. Steve Biko Campus, Mansfield Road, Durban, 4023 tel. 031 373 2286 fax. 031 373 2896</small>	drawing description WINDOW SCHEDULE	project file <table border="1"> <tr> <td>DATE:</td> <td>DRAWN BY:</td> <td>SCALE:</td> </tr> <tr> <td>19.07.2013</td> <td>MRA</td> <td>1:50</td> </tr> <tr> <td>PROJECT No:</td> <td>DRAWING No:</td> <td>REV.</td> </tr> <tr> <td>1009-11</td> <td>TD 03 - 1</td> <td>-</td> </tr> </table>	DATE:	DRAWN BY:	SCALE:	19.07.2013	MRA	1:50	PROJECT No:	DRAWING No:	REV.	1009-11	TD 03 - 1	-
DATE:	DRAWN BY:	SCALE:												
19.07.2013	MRA	1:50												
PROJECT No:	DRAWING No:	REV.												
1009-11	TD 03 - 1	-												

# W-17

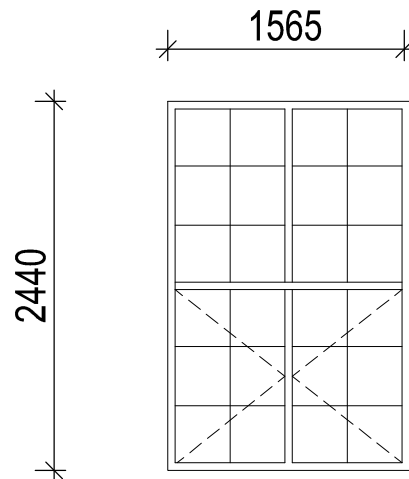

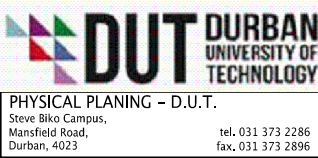

WINDOW TYPE	W17	QUANTITY	2
LOCATION	First floor: Corridor 3 & Corridor 4		
FRAME	Repair existing wooden frame: 1565x 2440mm		
GLAZING	4mm Clear Toughened Safety Glass puttied in with window putty as per N.B.R.		
FINISH	Sand and dust then apply 2 coats of 'Plascon' Velvagro paint: White		
GENERAL	<ul style="list-style-type: none"> <li>- All glazing to comply with SANS 10400-N:2012 Edition 3</li> <li>- All dimensions and levels to be checked on site and any discrepancies is to be referred to the author prior to any manufacturing.</li> <li>- Supplier to inspect all existing windows on site.</li> <li>- All new windows to match existing windows in proportion and opening sections.</li> </ul>		

professional team  <small>ARCHITECT: MURILYN YASVOO Reg No: 6928 22 Canford Park, 53 Anthony Road, Umgeni Park, Durban North, 4051 T: 031 250 1419/11 F: 031 250 4952 info@designscape.co.za   www.designscape.co.za</small>	project description REFURBISHMENT OF EXISTING ROOF FOR DRAMA STUDIES RITSON CAMPUS	revisions <table border="1"> <tr> <td>REV</td> <td>-</td> </tr> <tr> <td>BY</td> <td>MRA</td> </tr> <tr> <td>DATE</td> <td>01.08.2013</td> </tr> <tr> <td>DESCRIPTION</td> <td>ISSUED FOR INFORMATION</td> </tr> </table>	REV	-	BY	MRA	DATE	01.08.2013	DESCRIPTION	ISSUED FOR INFORMATION	SHEET 18			
REV	-													
BY	MRA													
DATE	01.08.2013													
DESCRIPTION	ISSUED FOR INFORMATION													
client details  <small>PHYSICAL PLANING - D.U.T. Steve Biko Campus, Mansfield Road, Durban, 4023 tel. 031 373 2286 fax. 031 373 2896</small>	drawing description WINDOW SCHEDULE	project file <table border="1"> <tr> <td>DATE:</td> <td>DRAWN BY</td> <td>SCALE</td> </tr> <tr> <td>19.07.2013</td> <td>MRA</td> <td>1:50</td> </tr> <tr> <td>PROJECT No:</td> <td>DRAWING No:</td> <td>REV.</td> </tr> <tr> <td>1009-11</td> <td>TD 03 - 1</td> <td>-</td> </tr> </table>	DATE:	DRAWN BY	SCALE	19.07.2013	MRA	1:50	PROJECT No:	DRAWING No:	REV.	1009-11	TD 03 - 1	-
DATE:	DRAWN BY	SCALE												
19.07.2013	MRA	1:50												
PROJECT No:	DRAWING No:	REV.												
1009-11	TD 03 - 1	-												

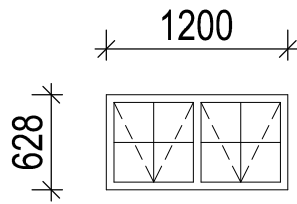
# W-18



WINDOW TYPE	W18	QUANTITY	2
LOCATION	Upper Floor: Changeroom 104		
FRAME			
GLAZING			
FINISH			
GENERAL	Fit new blinds		

professional team	project description	revisions		SHEET 19
 <small>ARCHITECT: MERLON IYAVOO Reg No: 6828</small>	REFURBISHMENT OF EXISTING ROOF FOR DRAMA STUDIES RITSON CAMPUS	REV	-	
<small>22 Canford Park, 59 Anthony Road, Umgeni Park, Durban North, 4061 t: 031 263 7470   f: 031 263 4952 info@designscape.co.za   www.designscape.co.za</small>	drawing description	BY	MRA	
client details	WINDOW SCHEDULE	DATE	01.08.2013	
 <small>PHYSICAL PLANING - D.U.T. Steve Biko Campus, Mansfield Road, Durban, 4023</small>		DESCRIPTION	ISSUED FOR INFORMATION	
<small>tel. 031 373 2286 fax. 031 373 2896</small>		project file		
DATE: 19.07.2013	DRAWN BY MRA	SCALE 1:50	PROJECT No: 1009-11	
	DRAWING No: TD 03 - 1	REV. -		

# W-19

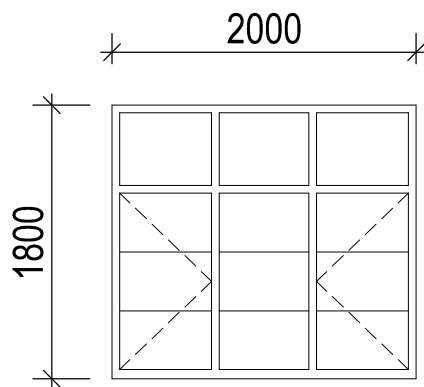



WINDOW TYPE	W19	QUANTITY	2
LOCATION	First floor: Office 1 - 203 & Store 209		
FRAME	Purpose made wooden frame: 2000x 1800mm supplied by 'Swartland'		
GLAZING	4mm Clear Toughened Safety Glass puttied in with window putty as per N.B.R.		
FINISH	Sand and dust then apply 2 coats of 'Plascon' Velvagro paint: White		
GENERAL	<ul style="list-style-type: none"> <li>- All glazing to comply with SANS 10400-N:2012 Edition 3</li> <li>- All dimensions and levels to be checked on site and any discrepancies is to be referred to the author prior to any manufacturing.</li> <li>- Supplier to inspect all existing windows on site.</li> <li>- All new windows to match existing windows in proportion and opening sections.</li> </ul>		

professional team  <small>ARCHITECT: MARLON NYAVOC 22 Carford Park, 53 Anthony Road, Umqeni Park, Durban North, 4291 Reg No: 6525 t: 031 563 7475   f: 031 563 4852 info@designscape.co.za   www.designscape.co.za</small>	project description REFURBISHMENT OF EXISTING ROOF FOR DRAMA STUDIES RITSON CAMPUS	revisions <table border="1"> <tr> <td>REV</td> <td>-</td> </tr> <tr> <td>BY</td> <td>MRA</td> </tr> <tr> <td>DATE</td> <td>01.08.2013</td> </tr> <tr> <td>DESCRIPTION</td> <td>ISSUED FOR INFORMATION</td> </tr> </table>	REV	-	BY	MRA	DATE	01.08.2013	DESCRIPTION	ISSUED FOR INFORMATION	SHEET 20				
REV	-														
BY	MRA														
DATE	01.08.2013														
DESCRIPTION	ISSUED FOR INFORMATION														
client details PHYSICAL PLANING – D.U.T. <small>Steve Biko Campus, Mansfield Road, Durban, 4023 tel. 031 373 2286 fax. 031 373 2896</small>	drawing description WINDOW SCHEDULE	project file <table border="1"> <tr> <td>DATE:</td> <td>19.07.2013</td> <td>DRAWN BY:</td> <td>MRA</td> <td>SCALE:</td> <td>1:50</td> </tr> <tr> <td>PROJECT No:</td> <td>1009-11</td> <td>DRAWING No:</td> <td>TD 03 - 1</td> <td>REV.:</td> <td>-</td> </tr> </table>	DATE:	19.07.2013	DRAWN BY:	MRA	SCALE:	1:50	PROJECT No:	1009-11	DRAWING No:	TD 03 - 1	REV.:	-	
DATE:	19.07.2013	DRAWN BY:	MRA	SCALE:	1:50										
PROJECT No:	1009-11	DRAWING No:	TD 03 - 1	REV.:	-										

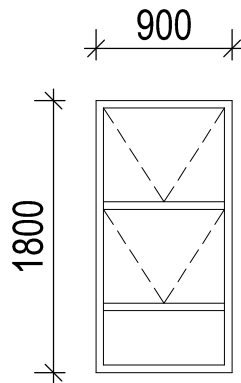
# W-20



WINDOW TYPE	W20	QUANTITY	4
LOCATION	Upper ground floor: Workshop and Storage		
FRAME			
GLAZING			
FINISH			
GENERAL	Fit new blinds		

professional team  ARCHITECT: MRS LONNYA VOO Reg No: 6828 22 Canford Park, 53 Anthony Road, Umgeni Park, Durban North, 4061 t. 031 282 7476   f. 031 284 4962 info@designscape.co.za   www.designscape.co.za	project description REFURBISHMENT OF EXISTING ROOF FOR DRAMA STUDIES RITSON CAMPUS	revisions <table border="1"> <tr> <td>REV</td> <td>-</td> </tr> <tr> <td>BY</td> <td>MRA</td> </tr> <tr> <td>DATE</td> <td>01.08.2013</td> </tr> <tr> <td>DESCRIPTION</td> <td>ISSUED FOR INFORMATION</td> </tr> </table>	REV	-	BY	MRA	DATE	01.08.2013	DESCRIPTION	ISSUED FOR INFORMATION	SHEET 21			
REV	-													
BY	MRA													
DATE	01.08.2013													
DESCRIPTION	ISSUED FOR INFORMATION													
client details  PHYSICAL PLANING - D.U.T. Steve Biko Campus, Mansfield Road, Durban, 4023 tel. 031 373 2286 fax. 031 373 2896	drawing description WINDOW SCHEDULE	project file <table border="1"> <tr> <td>DATE:</td> <td>DRAWN BY:</td> <td>SCALE:</td> </tr> <tr> <td>19.07.2013</td> <td>MRA</td> <td>1:50</td> </tr> <tr> <td>PROJECT No:</td> <td>DRAWING No:</td> <td>REV.</td> </tr> <tr> <td>1009-11</td> <td>TD 03 - 1</td> <td>-</td> </tr> </table>	DATE:	DRAWN BY:	SCALE:	19.07.2013	MRA	1:50	PROJECT No:	DRAWING No:	REV.	1009-11	TD 03 - 1	-
DATE:	DRAWN BY:	SCALE:												
19.07.2013	MRA	1:50												
PROJECT No:	DRAWING No:	REV.												
1009-11	TD 03 - 1	-												

# W-21

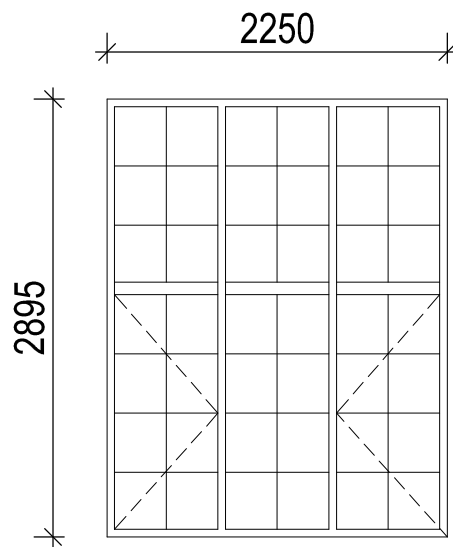

WINDOW TYPE	W21	QUANTITY	5
LOCATION	Upper ground floor: Workshop & Storage and Rehearsal room 112 & 113		
FRAME			
GLAZING			
FINISH			
GENERAL	Fit new blinds		

professional team



ARCHITECT: M/ROLON NYAVOO 22 Canford Park, 53 Anthony Road,  
Umgeni Park, Durban North, 4081  
Reg No: 6628 t: 031 252 7475 | f: 031 263 4982  
info@designscape.co.za | www.designscape.co.za

project description

REFURBISHMENT OF EXISTING ROOF FOR DRAMA STUDIES :  
RITSON CAMPUS

revisions

REV	-
BY	MRA
DATE	01.08.2013
DESCRIPTION	ISSUED FOR INFORMATION

SHEET 22

client details



PHYSICAL PLANING - D.U.T.  
Steve Biko Campus,  
Mansfield Road,  
Durban, 4023  
tel. 031 373 2286  
fax. 031 373 2896

drawing description

WINDOW SCHEDULE



project file

DATE: 19.07.2013	DRAWN BY MRA	SCALE 1:50
PROJECT No: 1009-11	DRAWING No: TD 03 - 1	REV. -

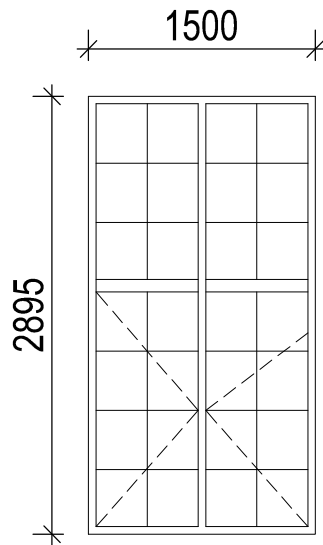
# W-22



WINDOW TYPE	W22	QUANTITY	1
LOCATION	Upper ground floor: Rehearsal room 112		
FRAME			
GLAZING			
FINISH			
GENERAL	Fit new blinds		



<p>professional team</p>  <p>ARCHITECT: MRS LON YIYAVOO Reg No: 6828</p> <p>22 Canford Park, 53 Anthony Road, Umgeni Park, Durban North, 4061 t: 031 262 7476   f: 031 264 4962 info@designscape.co.za   www.designscape.co.za</p>	<p>project description</p> <p>REFURBISHMENT OF EXISTING ROOF FOR DRAMA STUDIES RITSON CAMPUS</p>	<p>revisions</p> <table border="1"> <tr> <td>REV</td> <td>-</td> </tr> <tr> <td>BY</td> <td>MRA</td> </tr> <tr> <td>DATE</td> <td>01.08.2013</td> </tr> <tr> <td>DESCRIPTION</td> <td>ISSUED FOR INFORMATION</td> </tr> </table> <p>SHEET 23</p>	REV	-	BY	MRA	DATE	01.08.2013	DESCRIPTION	ISSUED FOR INFORMATION				
REV	-													
BY	MRA													
DATE	01.08.2013													
DESCRIPTION	ISSUED FOR INFORMATION													
<p>client details</p>  <p>PHYSICAL PLANING - D.U.T. Steve Biko Campus, Mansfield Road, Durban, 4023</p> <p>tel. 031 373 2286 fax. 031 373 2896</p>	<p>drawing description</p> <p>WINDOW SCHEDULE</p>	<p>project file</p> <table border="1"> <tr> <td>DATE:</td> <td>DRAWN BY:</td> <td>SCALE:</td> </tr> <tr> <td>19.07.2013</td> <td>MRA</td> <td>1:50</td> </tr> <tr> <td>PROJECT No:</td> <td>DRAWING No:</td> <td>REV.</td> </tr> <tr> <td>1009-11</td> <td>TD 03 - 1</td> <td>-</td> </tr> </table>	DATE:	DRAWN BY:	SCALE:	19.07.2013	MRA	1:50	PROJECT No:	DRAWING No:	REV.	1009-11	TD 03 - 1	-
DATE:	DRAWN BY:	SCALE:												
19.07.2013	MRA	1:50												
PROJECT No:	DRAWING No:	REV.												
1009-11	TD 03 - 1	-												

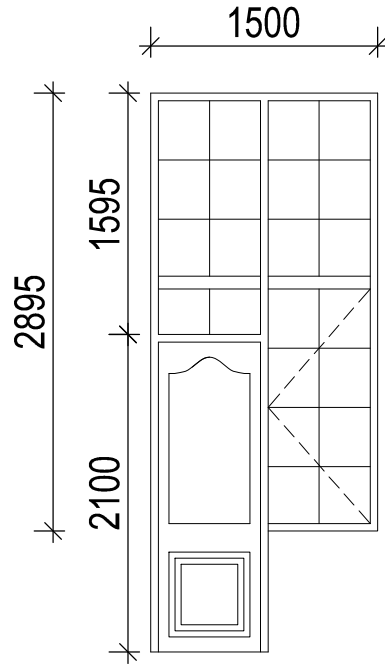

# W-23





WINDOW TYPE	W23	QUANTITY	3
LOCATION	Upper ground floor: Rehearsal room 113		
FRAME			
GLAZING			
FINISH			
GENERAL	Fit new blinds		

<p>professional team</p>  <p>ARCHITECT: MKRGLGN IYAVOO 22 Canford Park, 58 Anthony Road, Umhlanga Park, Durban North, 4091 T: 031 652 4476   F: 031 652 4992 info@designscape.co.za   www.designscape.co.za</p>	<p>project description</p> <p>REFURBISHMENT OF EXISTING ROOF FOR DRAMA STUDIES RITSON CAMPUS</p>	<p>revisions</p> <table border="1"> <tr> <td>REV</td> <td>-</td> </tr> <tr> <td>BY</td> <td>MRA</td> </tr> <tr> <td>DATE</td> <td>01.08.2013</td> </tr> <tr> <td>DESCRIPTION</td> <td>ISSUED FOR INFORMATION</td> </tr> </table> <p>SHEET 24</p>	REV	-	BY	MRA	DATE	01.08.2013	DESCRIPTION	ISSUED FOR INFORMATION				
REV	-													
BY	MRA													
DATE	01.08.2013													
DESCRIPTION	ISSUED FOR INFORMATION													
<p>client details</p>  <p>PHYSICAL PLANING – D.U.T. Steve Biko Campus, Mansfield Road, Durban, 4023 tel. 031 373 2286 fax. 031 373 2896</p>	<p>drawing description</p> <p>WINDOW SCHEDULE</p>	<p>project file</p> <table border="1"> <tr> <td>DATE:</td> <td>19.07.2013</td> <td>DRAWN BY:</td> <td>MRA</td> <td>SCALE:</td> <td>1:50</td> </tr> <tr> <td>PROJECT No:</td> <td>1009-11</td> <td>DRAWING No:</td> <td>TD 03 - 1</td> <td>REV.:</td> <td>-</td> </tr> </table>	DATE:	19.07.2013	DRAWN BY:	MRA	SCALE:	1:50	PROJECT No:	1009-11	DRAWING No:	TD 03 - 1	REV.:	-
DATE:	19.07.2013	DRAWN BY:	MRA	SCALE:	1:50									
PROJECT No:	1009-11	DRAWING No:	TD 03 - 1	REV.:	-									

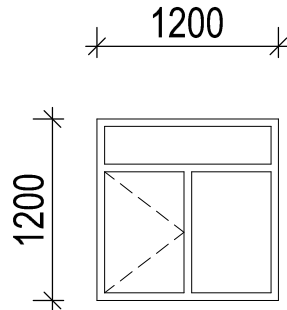
# W-24





WINDOW TYPE	W24	QUANTITY	1
LOCATION	First floor: Passage		
FRAME			
GLAZING			
FINISH			
GENERAL	Fit new blinds		

professional team  <small>ARCHITECT: MGR/CLN/174/000 Reg No: 6628</small> <small>22 Canford Park, 68 Anthony Road, Umgeni Park, Durban North, 4061 T: 031 662 7476   F: 031 664 4992 info@designscape.co.za   www.designscape.co.za</small>	project description REFURBISHMENT OF EXISTING ROOF FOR DRAMA STUDIES RITSON CAMPUS	revisions <table border="1"> <tr> <td>REV</td> <td>-</td> </tr> <tr> <td>BY</td> <td>MRA</td> </tr> <tr> <td>DATE</td> <td>01.08.2013</td> </tr> <tr> <td>DESCRIPTION</td> <td>ISSUED FOR INFORMATION</td> </tr> </table>	REV	-	BY	MRA	DATE	01.08.2013	DESCRIPTION	ISSUED FOR INFORMATION	SHEET 25			
REV	-													
BY	MRA													
DATE	01.08.2013													
DESCRIPTION	ISSUED FOR INFORMATION													
client details  PHYSICAL PLANING - D.U.T. <small>Steve Biko Campus, Mansfield Road, Durban, 4023</small> <small>tel. 031 373 2286 fax. 031 373 2896</small>	drawing description WINDOW SCHEDULE	project file <table border="1"> <tr> <td>DATE:</td> <td>DRAWN BY:</td> <td>SCALE:</td> </tr> <tr> <td>19.07.2013</td> <td>MRA</td> <td>1:50</td> </tr> <tr> <td>PROJECT No:</td> <td>DRAWING No:</td> <td>REV.</td> </tr> <tr> <td>1009-11</td> <td>TD 03 - 1</td> <td>-</td> </tr> </table>	DATE:	DRAWN BY:	SCALE:	19.07.2013	MRA	1:50	PROJECT No:	DRAWING No:	REV.	1009-11	TD 03 - 1	-
DATE:	DRAWN BY:	SCALE:												
19.07.2013	MRA	1:50												
PROJECT No:	DRAWING No:	REV.												
1009-11	TD 03 - 1	-												

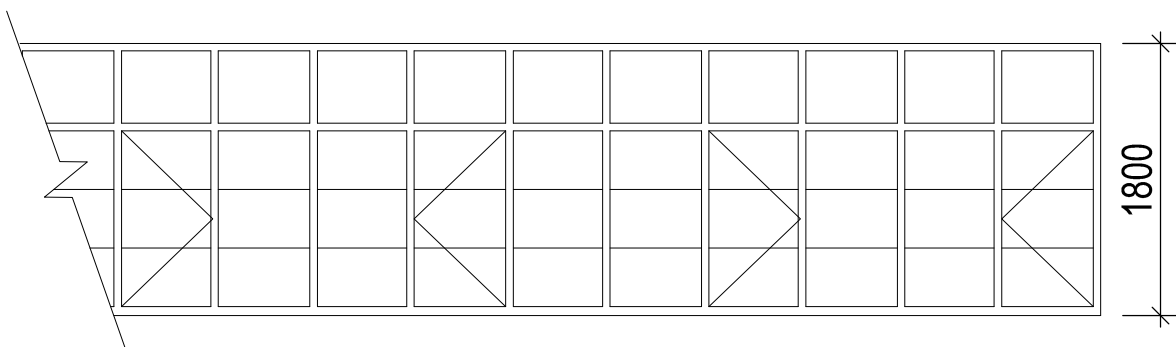
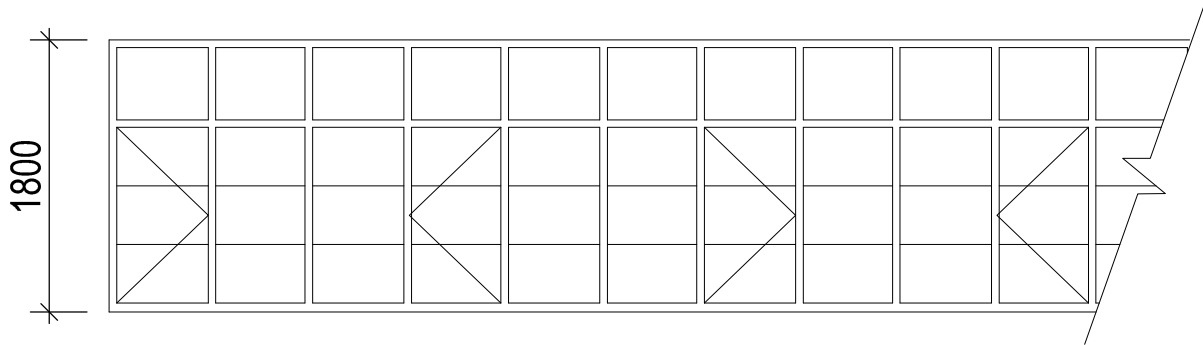
# W-26



WINDOW TYPE	W26	QUANTITY	1
LOCATION	First floor: Computer room 210 & Costume room 212		
FRAME	White powder coated epoxy frame: 21242mm x 1800mm		
GLAZING	4mm Clear Toughened Safety Glass puttied in with steel window putty as per N.B.R.		
FINISH	'Plascon' Velvaglo paint: White		
GENERAL	All glazing to comply with part 'n' of SANS 10400-A:2010 Edition 3.1 All dimensions and levels to be checked on site and any discrepancies is to be referred to the author prior to any manufacturing.		

<b>professional team</b>  <small>ARCHITECT: MARILYN NYIWOO 22 Canford Park, 55 Anthony Road, Umqeni Park, Durban North, 4091 Reg No: 6626 t: 031 252 7478   f: 031 263 4992 info@designscape.co.za   www.designscape.co.za</small>	<b>project description</b> REFURBISHMENT OF EXISTING ROOF FOR DRAMA STUDIES RITSON CAMPUS	<b>revisions</b> <table border="1"> <tr> <td>REV</td> <td>-</td> </tr> <tr> <td>BY</td> <td>MRA</td> </tr> <tr> <td>DATE</td> <td>09.08.2013</td> </tr> <tr> <td>DESCRIPTION</td> <td>ISSUED FOR INFORMATION</td> </tr> </table>	REV	-	BY	MRA	DATE	09.08.2013	DESCRIPTION	ISSUED FOR INFORMATION	<b>SHEET 27</b>				
REV	-														
BY	MRA														
DATE	09.08.2013														
DESCRIPTION	ISSUED FOR INFORMATION														
<b>client details</b>  <small>PHYSICAL PLANING - D.U.T. Steve Biko Campus, Mansfield Road, Durban, 4023 tel. 031 373 2286 fax. 031 373 2896</small>	<b>drawing description</b> WINDOW SCHEDULE	<b>project file</b> <table border="1"> <tr> <td>DATE:</td> <td>DRAWN BY:</td> <td>SCALE:</td> </tr> <tr> <td>19.07.2013</td> <td>MRA</td> <td>1:50</td> </tr> <tr> <td>PROJECT No:</td> <td>DRAWING No:</td> <td>REV.</td> </tr> <tr> <td>1009-11</td> <td>TD 03 - 1</td> <td>-</td> </tr> </table>	DATE:	DRAWN BY:	SCALE:	19.07.2013	MRA	1:50	PROJECT No:	DRAWING No:	REV.	1009-11	TD 03 - 1	-	
DATE:	DRAWN BY:	SCALE:													
19.07.2013	MRA	1:50													
PROJECT No:	DRAWING No:	REV.													
1009-11	TD 03 - 1	-													

	R	RB	K	KB	G	N	SIZE:
W01		6					2350 x 688
W02		1	4				780 x 1800
W03					7	1	1200 x 1650
W04			3				1517 x 1652
W05			1				1517 x 1275
W06			2			2	2250 x 1652
W07			1				625 x 1650
W08		2	1				1200 x 1650
W09		1					2250 x 1652
W10		1					2350 x 1650
W11		1	1				1200 x 1300
W12		6		12			600 x 628
W13						2	2250x1652
W14			2				1500 x 2408
W15			4				2250 x 3680
W16			6				750 x 2408
W17						2	1600 x 2440
W18				2			1200 x 628
W19		1	1				2000 x 2210
W20				4	1		900 x 1800
W21				1	3		2250 x 3426
W22					1		1500 x 3426
W23					3		740 x 3426
W24					1		1200 x 1200
W25			1				2200 x 400
W26			1				21245x1800
W27					14		1200 x 1650
W28					1		1700 x 1650
W29					4		1200 x 1300
W30					1		1200 x 1100
W31		1					1200 x 1850

professional team



client details

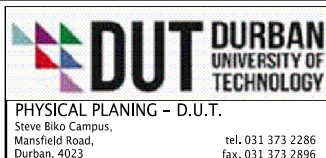

project description

REFURBISHMENT OF EXISTING ROOF FOR DRAMA STUDIES  
 RITSON CAMPUS

drawing description

WINDOW DATA SHEET

revisions

REV	DESCRIPTION
-	ISSUED FOR INFORMATION
BY	MRA
DATE	01.08.2013

SHE



project file

DATE:	DRAWN BY	SCALE
19.07.2013	MRA	-
PROJECT No:	DRAWING No:	REV.
1009-11	TD 03 - 1	-

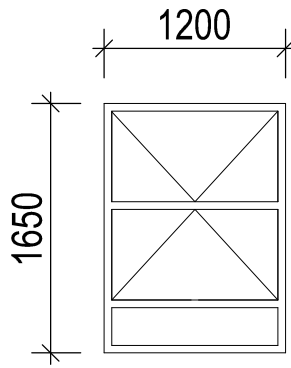
# W-27



WINDOW TYPE	W27	QUANTITY	14
LOCATION	Upper ground floor: Office 1,Dressing Room, Change Room, Computer Lab,Laundry Room, Showers		
FRAME			
GLAZING			
FINISH			
GENERAL	Fit new blinds		

professional team  <small>ARCHITECT: MARLON IYAVOO 22 Canford Park, 53 Anthony Road, Umhlanga Park, Durban North, 4001 Reg No: 2626 : 031 363 1410/11 : 031 963 4992 info@dscape.co.za   www.dscape.co.za</small>	project description REFURBISHMENT OF EXISTING ROOF FOR DRAMA STUDIES RITSON CAMPUS	revisions <table border="1"> <tr> <td>REV</td> <td>-</td> </tr> <tr> <td>BY</td> <td>MRA</td> </tr> <tr> <td>DATE</td> <td>01.08.2013</td> </tr> <tr> <td>DESCRIPTION</td> <td>ISSUED FOR INFORMATION</td> </tr> </table>	REV	-	BY	MRA	DATE	01.08.2013	DESCRIPTION	ISSUED FOR INFORMATION	SHEET 28				
REV	-														
BY	MRA														
DATE	01.08.2013														
DESCRIPTION	ISSUED FOR INFORMATION														
client details  <small>PHYSICAL PLANING – D.U.T. Steve Biko Campus, Mansfield Road, Durban, 4023 tel. 031 373 2286 fax. 031 373 2896</small>	drawing description WINDOW SCHEDULE	project file <table border="1"> <tr> <td>DATE:</td> <td>19.07.2013</td> <td>DRAWN BY</td> <td>MRA</td> <td>SCALE</td> <td>1:50</td> </tr> <tr> <td>PROJECT No:</td> <td>1009-11</td> <td>DRAWING No:</td> <td>TD 01 - 20</td> <td>REV.</td> <td>-</td> </tr> </table>	DATE:	19.07.2013	DRAWN BY	MRA	SCALE	1:50	PROJECT No:	1009-11	DRAWING No:	TD 01 - 20	REV.	-	
DATE:	19.07.2013	DRAWN BY	MRA	SCALE	1:50										
PROJECT No:	1009-11	DRAWING No:	TD 01 - 20	REV.	-										

# W-28

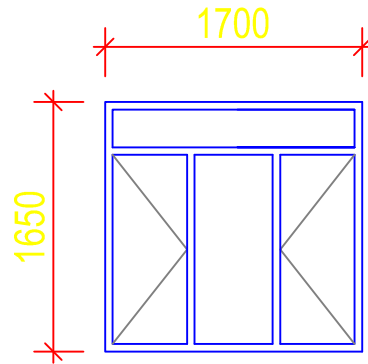

WINDOW TYPE	W28	QUANTITY	1
LOCATION	Upper ground floor: Office 6		
FRAME			
GLAZING			
FINISH			
GENERAL	Fit new blinds		

professional team



project description

REFURBISHMENT OF EXISTING ROOF FOR DRAMA STUDIES  
RITSON CAMPUS

revisions

REV	-
BY	MRA
DATE	01.08.2013
DESCRIPTION	ISSUED FOR INFORMATION

SHEET 29

client details



drawing description

WINDOW SCHEDULE

project file

DATE:	19.07.2013	DRAWN BY:	MRA	SCALE:	1:50
PROJECT No:	1009-11	DRAWING No:	TD 01 - 20	REV:	-

# W-29

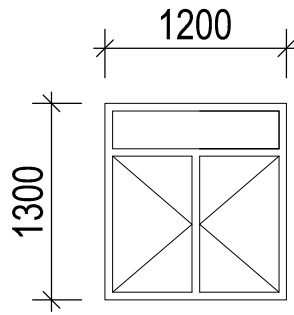

WINDOW TYPE	W29	QUANTITY	4
LOCATION	First floor: Passage, Classroom 202, Store 1		
FRAME			
GLAZING			
FINISH			
GENERAL	Fit new blinds		

professional team



project description

REFURBISHMENT OF EXISTING ROOF FOR DRAMA STUDIES :  
RITSON CAMPUS

revisions

REV	-
BY	MRA
DATE	01.08.2013
DESCRIPTION	ISSUED FOR INFORMATION

SHEET 30

client details

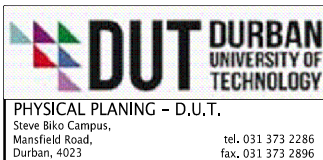

drawing description

WINDOW SCHEDULE



project file

DATE:	19.07.2013	DRAWN BY:	MRA	SCALE:	1:50
PROJECT No:	1009-11	DRAWING No:	TD 01 - 20	REV.:	-

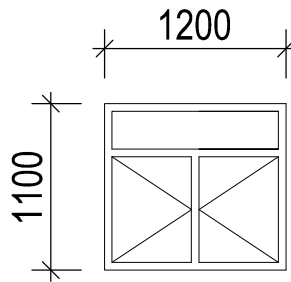
# W-30



WINDOW TYPE	W30	QUANTITY	1
LOCATION	First floor: Passage		
FRAME			
GLAZING			
FINISH			
GENERAL	Fit new blinds		

<p>professional team</p>  <p>ARCHITECT: MARILYN HYWOOD Reg No: 6528</p> <p>22 Canford Park, 63 Anthony Road, Umgeni Park, Durban North, 4001 t. 031 263 7476   f. 031 263 4992 info@designscape.co.za   www.designscape.co.za</p>	<p>project description</p> <p>REFURBISHMENT OF EXISTING ROOF FOR DRAMA STUDIES RITSON CAMPUS</p>	<p>revisions</p> <table border="1"> <tr> <td>REV</td> <td>-</td> </tr> <tr> <td>BY</td> <td>MRA</td> </tr> <tr> <td>DATE</td> <td>01.08.2013</td> </tr> </table> <p>DESCRIPTION ISSUED FOR INFORMATION</p>	REV	-	BY	MRA	DATE	01.08.2013	SHEET 31						
REV	-														
BY	MRA														
DATE	01.08.2013														
<p>client details</p>  <p>PHYSICAL PLANING – D.U.T. Steve Biko Campus, Mansfield Road, Durban, 4023</p> <p>tel. 031 373 2286 fax. 031 373 2896</p>	<p>drawing description</p> <p>WINDOW SCHEDULE</p>	<p>project file</p> <table border="1"> <tr> <td>DATE:</td> <td>19.07.2013</td> <td>DRAWN BY:</td> <td>MRA</td> <td>SCALE:</td> <td>1:50</td> </tr> <tr> <td>PROJECT No:</td> <td>1009-11</td> <td>DRAWING No:</td> <td>TD 01 - 20</td> <td>REV.:</td> <td>-</td> </tr> </table>	DATE:	19.07.2013	DRAWN BY:	MRA	SCALE:	1:50	PROJECT No:	1009-11	DRAWING No:	TD 01 - 20	REV.:	-	
DATE:	19.07.2013	DRAWN BY:	MRA	SCALE:	1:50										
PROJECT No:	1009-11	DRAWING No:	TD 01 - 20	REV.:	-										



# W-31

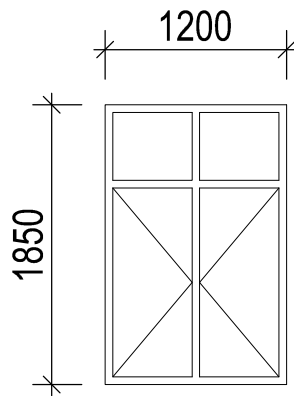

WINDOW TYPE	W31	QUANTITY	1
LOCATION	Upper Ground Floor: Printing Room & Props Store		
FRAME			
GLAZING			
FINISH			
GENERAL	Fit new blinds		

<b>DESIGNSCAPE</b> architects <small>ARCHITECT: MARLON HAYWOOD 22 Conford Park, 63 Anthony Road, Umgans Park, Durban North, 4051          Reg No: 6528          T: 031 282 7478   F: 031 263 4952          info@designscape.co.za   www.designscape.co.za</small>	<b>project description</b> REFURBISHMENT OF EXISTING ROOF FOR DRAMA STUDIES RITSON CAMPUS	<b>revisions</b> <table border="1"> <tr> <td>REV</td> <td>-</td> </tr> <tr> <td>BY</td> <td>MRA</td> </tr> <tr> <td>DATE</td> <td>01.08.2013</td> </tr> <tr> <td>DESCRIPTION</td> <td>ISSUED FOR INFORMATION</td> </tr> </table>	REV	-	BY	MRA	DATE	01.08.2013	DESCRIPTION	ISSUED FOR INFORMATION	<b>SHEET 32</b>			
REV	-													
BY	MRA													
DATE	01.08.2013													
DESCRIPTION	ISSUED FOR INFORMATION													
<b>client details</b>  <b>DUT DURBAN</b> UNIVERSITY OF TECHNOLOGY PHYSICAL PLANING – D.U.T. Steve Biko Campus, Mansfield Road, Durban, 4023 tel. 031 373 2286 fax. 031 373 2896	<b>drawing description</b> WINDOW SCHEDULE	<b>project file</b> <table border="1"> <tr> <td>DATE:</td> <td>19.07.2013</td> <td>DRAWN BY:</td> <td>MRA</td> <td>SCALE:</td> <td>1:50</td> </tr> <tr> <td>PROJECT No:</td> <td>1009-11</td> <td>DRAWING No:</td> <td>TD 01 - 20</td> <td>REV.</td> <td>-</td> </tr> </table>	DATE:	19.07.2013	DRAWN BY:	MRA	SCALE:	1:50	PROJECT No:	1009-11	DRAWING No:	TD 01 - 20	REV.	-
DATE:	19.07.2013	DRAWN BY:	MRA	SCALE:	1:50									
PROJECT No:	1009-11	DRAWING No:	TD 01 - 20	REV.	-									



4517

**W-32**

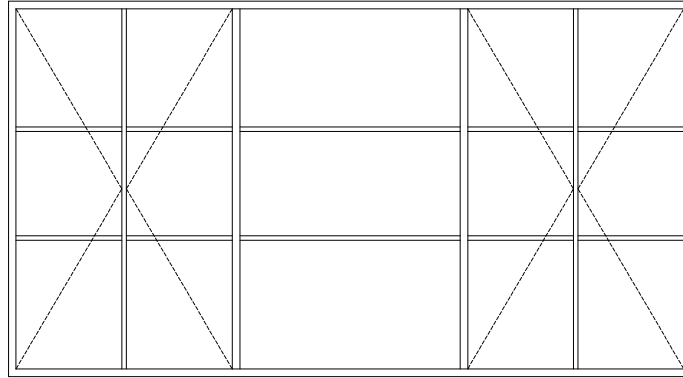
2482



WINDOW TYPE	W32	QUANTITY	1
LOCATION	Upper Ground Floor: Store & Kitchen		
FRAME	White epoxy aluminium frame: 1200 x 1650mm supplied by 'Pro Aluminium'		
GLAZING	4mm Clear Toughened Safety Glass puttied in with window putty as per N.B.R.		
FINISH	White epoxy aluminium frame		
GENERAL	<ul style="list-style-type: none"> <li>- All glazing to comply with SANS 10400-N:2012 Edition 3</li> <li>- All dimensions and levels to be checked on site and any discrepancies is to be referred to the author prior to any manufacturing.</li> <li>- Supplier to inspect all existing windows on site.</li> <li>- All new windows to match existing windows in proportion and opening sections.</li> </ul>		



<p>professional team</p>  <p>ARCHITECT: MURILYN NYAVOO Reg No: 2828</p> <p>22 Canford Park, 53 Anthony Road, Umgent Park, Durban North, 4051 t: 031 282 7478 f: 031 283 4952 info@designscape.co.za   www.designscape.co.za</p>	<p>project description</p> <p>REFURBISHMENT OF EXISTING ROOF FOR DRAMA STUDIES RITSON CAMPUS</p>	<p>revisions</p> <table border="1"> <tr> <td>REV</td> <td>-</td> </tr> <tr> <td>BY</td> <td>MRA</td> </tr> <tr> <td>DATE</td> <td>01.08.2013</td> </tr> <tr> <td>DESCRIPTION</td> <td>ISSUED FOR INFORMATION</td> </tr> </table>	REV	-	BY	MRA	DATE	01.08.2013	DESCRIPTION	ISSUED FOR INFORMATION				
REV	-													
BY	MRA													
DATE	01.08.2013													
DESCRIPTION	ISSUED FOR INFORMATION													
<p>client details</p>  <p>PHYSICAL PLANING - D.U.T. Steve Biko Campus, Mansfield Road, Durban, 4023</p> <p>tel. 031 373 2286 fax. 031 373 2896</p>	<p>drawing description</p> <p>WINDOW SCHEDULE</p>	<p>project file</p> <table border="1"> <tr> <td>DATE:</td> <td>DRAWN BY:</td> <td>SCALE:</td> </tr> <tr> <td>19.07.2013</td> <td>MRA</td> <td>1:50</td> </tr> <tr> <td>PROJECT No:</td> <td>DRAWING No:</td> <td>REV.</td> </tr> <tr> <td>1009-11</td> <td>TD 01 - 20</td> <td>-</td> </tr> </table>	DATE:	DRAWN BY:	SCALE:	19.07.2013	MRA	1:50	PROJECT No:	DRAWING No:	REV.	1009-11	TD 01 - 20	-
DATE:	DRAWN BY:	SCALE:												
19.07.2013	MRA	1:50												
PROJECT No:	DRAWING No:	REV.												
1009-11	TD 01 - 20	-												

SHEET 33

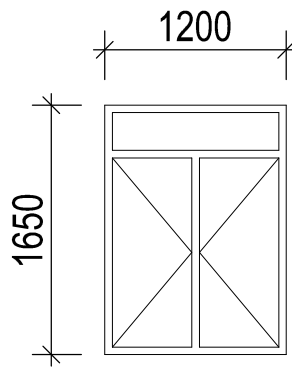
# W-33



WINDOW TYPE	W33	QUANTITY	1
LOCATION	Upper ground floor: Corridor 1		
FRAME	White epoxy aluminium frame: 1200 x 1650mm supplied by 'Pro Aluminium'		
GLAZING	4mm Clear Toughened Safety Glass puttied in with window putty as per N.B.R.		
FINISH	White epoxy aluminium frame		
GENERAL	<ul style="list-style-type: none"> <li>- All glazing to comply with SANS 10400-N:2012 Edition 3</li> <li>- All dimensions and levels to be checked on site and any discrepancies is to be referred to the author prior to any manufacturing.</li> <li>- Supplier to inspect all existing windows on site.</li> <li>- All new windows to match existing windows in proportion and opening sections.</li> </ul>		

professional team  <small>ARCHITECT: MIRON NIKOVIC 22 Carford Park, 53 Anthony Road, Umgeni Park, Durban North, 4061 Reg No: 5628 t: 031 553 7419   f: 031 263 4992 info@designscape.co.za   www.designscape.co.za</small>	project description REFURBISHMENT OF EXISTING ROOF FOR DRAMA STUDIES RITSON CAMPUS	revisions <table border="1"> <tr> <td>REV</td> <td>-</td> </tr> <tr> <td>BY</td> <td>MRA</td> </tr> <tr> <td>DATE</td> <td>01.08.2013</td> </tr> <tr> <td>DESCRIPTION</td> <td>ISSUED FOR INFORMATION</td> </tr> </table>	REV	-	BY	MRA	DATE	01.08.2013	DESCRIPTION	ISSUED FOR INFORMATION	SHEET 34				
REV	-														
BY	MRA														
DATE	01.08.2013														
DESCRIPTION	ISSUED FOR INFORMATION														
client details  PHYSICAL PLANING - D.U.T. Steve Biko Campus, Mansfield Road, Durban, 4023 tel. 031 373 2286 fax. 031 373 2896	drawing description WINDOW SCHEDULE	project file <table border="1"> <tr> <td>DATE:</td> <td>19.07.2013</td> <td>DRAWN BY:</td> <td>MRA</td> <td>SCALE:</td> <td>1:50</td> </tr> <tr> <td>PROJECT No:</td> <td>1009-11</td> <td>DRAWING No:</td> <td>TD 01 - 20</td> <td>REV.</td> <td>-</td> </tr> </table>	DATE:	19.07.2013	DRAWN BY:	MRA	SCALE:	1:50	PROJECT No:	1009-11	DRAWING No:	TD 01 - 20	REV.	-	
DATE:	19.07.2013	DRAWN BY:	MRA	SCALE:	1:50										
PROJECT No:	1009-11	DRAWING No:	TD 01 - 20	REV.	-										