

**HERITAGE IMPACT ASSESSMENT:
PROPOSED PROSPECTING ON PORTION 1 & REMAINDER
OF KAROETJIES KOP 150, VREDENDAL MAGISTERIAL
DISTRICT, WESTERN CAPE (10430PR)**

Required under Section 38(8) of the National Heritage Resources Act (No. 25 of 1999)

HWC Case No.: HWC23052609AM0529

Report for:

N.J. van Zyl

P.O. Box 255, Springbok, 8240
Email: klaaskraalbos@gmail.com

On behalf of:

Richwill Diamonds (Pty) Ltd



Dr Jayson Orton

ASHA Consulting (Pty) Ltd

40 Brassie Street, Lakeside, 7945
Tel: (021) 788 1025 | 083 272 3225
Email: jayson@asha-consulting.co.za

03 July 2023

SUMMARY

1. Site Name

Portion 1 and Remainder of Karoetjies Kop 150

2. Location

- Off local unnamed gravel access roads some 15 km south of Lepelfontein (in Northern Cape), 60 km west of Nuwerus and 60 km northwest of Koekenaap (both in Western Cape)
- Portion 1 and Remainder of Karoetjies Kop 150
- Centre point at S31° 11' 00" E17° 46' 10"

3. Locality Plan



Green polygon is prospecting right area, white polygon = Farm 150/RE, black line = provincial boundary. Local towns and places labelled.

4. Description of Proposed Development

The following is a general description of the proposed project:

PHASE 1a – Desk top Study (Literature Study, Imagery Analysis, Geological Mapping)

PHASE 1b: Geophysical Survey to supplement desktop work

PHASE 2 – Preliminary evaluation via prospecting pits (6x3 m) and reverse circulation drilling where bedrock is between 5 and 10 meters deep. Bulk sampling is excluded from this application but may be added in later if deemed appropriate.

PHASE 3 - Analytical Desktop Studies involving interpretation and modelling of all data gathered.

5. **Heritage Resources Identified**

The palaeontological specialist noted that although finds of bones and/or teeth in most formations would be scientifically important, such buried fossils are rare and their locations cannot be predicted. The main exception is the raised beach deposits which comprise mostly of extant species and are thus not of high sensitivity. The types of fossils most likely to occur in most of the study area are the bones of tortoises, moles, marine shells, shark and other fish teeth and casts of shells (steinkerns). Mammal bones and teeth are rare and far less likely to be encountered.

Many significant archaeological sites were recorded during the survey with a focus on the area within about 200 m of the beach. Sites were generally not present very close to the beach but a few exceptions were found. All were considered Grade IIIC.

The maritime archaeology assessment shows that a number of ships could potentially be wrecked in the area but, due to very limited information about most of them, the chances of encountering any are very low. While most wrecks are probably in the water, there is a chance of finding lifeboat debris or even graves of drowned sailors on land. Most ships are not culturally significant but potentially more significant ones would include the older ones, wartime losses and certain others with specific (and potentially unknown) reasons for higher significance.

The possibility of graves occurring in the study area was identified and a grave is known to occur at the farm complex. The complex is far from the study area and of no concern, while the locations of unmarked precolonial graves and the graves of sailors closer to the coast cannot be predicted.

The landscape is also a heritage resource and is mostly characterised by a very low level of anthropogenic modification. It is largely a natural landscape but extensive mining already occurs in the area to the south of Karoetjieskop and old prospecting pits occur sporadically in the study area. Furthermore, the immediate coastal zone has been heavily disturbed by the illegal use of off-road vehicles and many campsites have been constructed (platforms and fireplaces). Litter is common along the coast.

6. **Anticipated Impacts on Heritage Resources**

The palaeontological specialist noted that significant impacts to fossils would be unlikely due to the small areas to be disturbed and the relative scarcity of buried fossils.

Archaeological sites may be impacted by driving over them with the excavator or drill rig. Such impacts are likely to be of low significance and likely avoidable because of the many existing tracks that can be used. Although sites occur in section along the coastal road, such sites should not be impacted. If excavation occurs behind the beaches then impacts may occur.

The chances of any impacts on maritime archaeological resources are very small, but not impossible. The possibility of lifeboat debris or graves of sailors being found must also be borne in mind.

Graves may be impacted during excavation or drilling, but the chances are extremely small and grave locations cannot be predicted.

Impacts to the landscape are considered to be minimal as the excavator and/or drill rig will not visually dominate the landscape and the work will be temporary.

7. **Recommendations**

It is recommended that the proposed prospecting be authorised, but subject to the following recommendations which should be included as conditions of authorisation:

- A Fossil Chance Finds Procedure must be incorporated in the EMPr for the project and project staff must be made aware of the possibility of finding fossil bones during prospecting;
- The identified archaeologically sensitive areas (including the buffer zones) must be avoided as far as possible by all project activities;
- If avoidance is not possible then an archaeologist must be consulted with regards to the need for mitigation. It may be feasible to work within some of the buffers but if archaeological material will be at risk then mitigation excavations must be carried out in advance of prospecting;
- Project staff must be made aware of the possibility of finding further Stone Age sites in between those recorded and, should any shell scatters be seen, these must be avoided;
- Project staff must be made aware of the possibility of finding buried wreckage debris or even graves related to shipwrecks;
- No road widening may take place;
- Existing tracks should be used for access as far as possible;
- All prospecting sites must be rehabilitated; and
- If any archaeological terrestrial or maritime material, fossils or human burials are uncovered during the course of development then work in the immediate area should be halted. The find would need to be reported to the heritage authorities and may require inspection by an archaeologist or palaeontologist. Such heritage is the property of the state and may require excavation and curation in an approved institution.

8. **Author/s and Date**

Heritage Impact Assessment: Jayson Orton, ASHA Consulting (Pty) Ltd, 3 July 2023

Archaeological specialist study: Jayson Orton, ASHA Consulting (Pty) Ltd, 3 July 2023

Palaeontological specialist study: John Pether, 29 June 2023

Maritime archaeological study: Vanessa Maitland, 27 June 2023

Glossary

Acheulean: An archaeological name for the period comprising the later part of the Early Stone Age. This period started about 1.7-1.5 million years ago and ended about 250-200 thousand years ago.

Background scatter: Artefacts whose spatial position is conditioned more by natural forces than by human agency.

Cleaver: A bifacially flaked tool that has a sharp flat edge opposing the bulb.

Early Stone Age: Period of the Stone Age extending approximately between 2 million and 200 000 years ago.

Handaxe: A bifacially flaked, pointed stone tool type typical of the Early Stone Age Acheulian Industry. It is also referred to as a large cutting tool.

Holocene: The geological period spanning the last approximately 10-12 000 years.

Hominid: a group consisting of all modern and extinct great apes (i.e. gorillas, chimpanzees, orangutans and humans) and their ancestors.

Later Stone Age: Period of the Stone Age extending over the last approximately 20 000 years.

Middle Stone Age: Period of the Stone Age extending approximately between 200 000 and 20 000 years ago.

Pleistocene: The geological period beginning approximately 2.5 million years ago and preceding the Holocene.

Abbreviations

APHP: Association of Professional Heritage Practitioners

ASAPA: Association of Southern African Professional Archaeologists

BA: Basic Assessment

CRM: Cultural Resources Management

DMRE: Department of Mineral Resources and Energy

EMPr: Environmental Management Program

ESA: Early Stone Age

GPS: global positioning system

HIA: Heritage Impact Assessment

HWC: Heritage Western Cape

LSA: Later Stone Age

MSA: Middle Stone Age

NCW: Not Conservation Worthy

NEMA: National Environmental Management Act (No. 107 of 1998)

NHRA: National Heritage Resources Act (No. 25) of 1999

NID: Notification of Intent to Develop

PPP: Public Participation Process

SAHRA: South African Heritage Resources Agency

SAHRIS: South African Heritage Resources Information System

Contents

Glossary	v
Abbreviations	vi
1. INTRODUCTION	1
1.1. The proposed project	1
1.1.1. Project description	1
1.1.2. Identification of alternatives.....	4
1.1.3. Aspects of the project relevant to the heritage study.....	4
1.2. Terms of reference	4
1.3. Scope and purpose of the report	5
1.4. The author	5
1.5. Declaration of independence	6
2. LEGISLATIVE CONTEXT	6
2.1. National Heritage Resources Act (NHRA) No. 25 of 1999	6
2.2. Approvals and permits.....	7
2.2.1. Assessment Phase	7
2.2.2. Construction Phase	7
2.3. Guidelines	7
2.4. Application timeline.....	8
3. METHODS	8
3.1. Literature survey and information sources	8
3.2. Field survey	9
3.3. Specialist studies.....	10
3.4. Grading	10
3.5. Consultation.....	11
3.6. Assumptions and limitations	11
4. PHYSICAL ENVIRONMENTAL CONTEXT	11
4.1. Site context	11
4.2. Site description	11
5. FINDINGS OF THE HERITAGE STUDY	16
5.1. Palaeontology	16
5.2. Archaeology	36
5.2.1. Desktop study.....	36
5.2.2. Site visit	38
5.3. Maritime heritage.....	45
5.4. Graves	45
5.5. Historical aspects and the Built environment	45
5.5.1. Desktop study.....	45
5.5.2. Site visit	46
5.6. Cultural landscapes and scenic routes	46
5.7. Statement of significance and provisional grading	47
5.8. Summary of heritage indicators	53

6. ASSESSMENT OF IMPACTS	54
6.1. Impacts to archaeological resources	54
6.2. Impacts to graves.....	55
6.3. Impacts to the cultural landscape	55
6.4. Cumulative impacts	56
6.5. Evaluation of impacts relative to sustainable social and economic benefits.....	56
6.6. Existing impacts to heritage resources.....	56
6.7. The No-Go alternative	57
6.8. Levels of acceptable change	57
7. INPUT TO THE ENVIRONMENTAL MANAGEMENT PROGRAMME	57
8. CONSULTATION WITH HERITAGE CONSERVATION BODIES	58
9. CONCLUSIONS	58
9.1. Reasoned opinion of the specialist.....	59
10. RECOMMENDATIONS	59
11. REFERENCES	60
APPENDIX 1 – Curriculum Vitae	66
APPENDIX 2 – Mapping	68
APPENDIX 3 – Palaeotological specialist study	79

1. INTRODUCTION

ASHA Consulting (Pty) Ltd was appointed by N.J. van Zyl to conduct an assessment of the potential impacts to heritage resources that might occur through proposed prospecting on Portion 1 and the remainder of the farm Karoetjies Kop 150, Vredendal Magisterial District. The site is located off local unnamed gravel access roads some 15 km south of Lepelsfontein (in Northern Cape), 54 km west of Nuwerus and 60 km northwest of Koekenaap (both in Western Cape; Figure 1). The study area lies along the south-western side of the farm (adjacent to the coastline; Figure 2) and is centred on $S31^{\circ} 11' 00'' E17^{\circ} 46' 10''$.

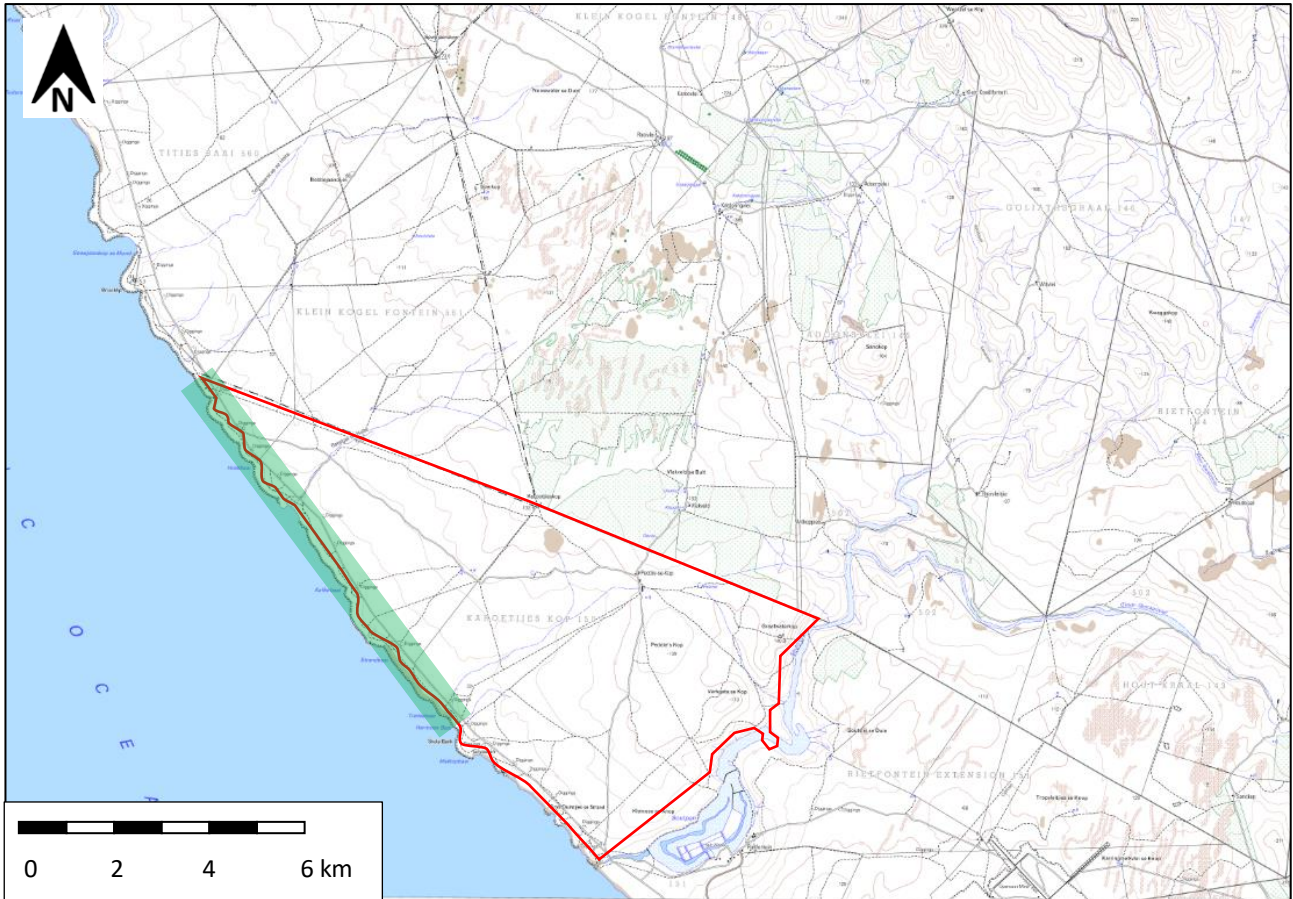

Figure 1: Extract from 1:50 000 topographic map 3117BB_BA (dated 2003) showing the location of the site (red polygon = farm boundary, green shading = prospecting area). Source of basemap: Chief Directorate: National Geo-Spatial Information. Website: www.ngi.gov.za.

1.1. The proposed project

1.1.1. Project description

PHASE 1a – Desk top Study (Literature Study, Imagery Analysis, Geological Mapping)

This will comprise a desktop review of all information and data gathered by previous exploration in the surrounding area as well as review of aerial photography and satellite imagery to aid with structural and geological mapping of the prospecting area and surrounds.



Figure 2: Aerial view showing the study area (green polygon) in its local context. The remainder of Karoetjieskop is shown by the white polygon, while the narrow strip along the coast is Portion 1.

PHASE 1b: Geophysical Survey

During this phase the desktop studies will be supplemented by field observations. Ground Resistivity measurements will also be used to “home in” on target areas. Any anomalous features identified will be mapped in detail. The final purpose of phase 1 will be to determine bedrock elevation contours and potential diamond traps.

PHASE 2 – Preliminary evaluation

This phase will determine a ballpark estimate of grade and size and thus possible in-situ value of the deposit. This is normally established by collecting mini samples by the most cost-effective method available. Due to the relative shallow overburden prospecting pits is the most common technique, and will be employed on areas where bedrock depth is less than 5 meters (e.g. in the historic diggings where overburden has already been removed). Provision is, however, also made for reverse circulation drilling where bedrock depth is more than 5 meters and up to 10 meters.

Prospecting Pits

Pit development will be the same as for trench development (Bulk Sampling) as shown in Figure 3 but on a much smaller scale. There will only ever be three prospecting pits open at any given time, one in the process of rehabilitation, one that is operational and one in the process of development and it is anticipated that no more than 10 such pits will be developed. After results are logged the pit will be backfilled immediately for security and safety reasons before the project moves to the next pit position. In case of sudden closure of the project there will only be one open pit to be dealt with as part of final decommissioning and rehabilitation. The pits would be 2-5 m deep and 6 m by 3 m in size.

Total footprint of surface disturbance from 10 Prospecting pits: 180m² plus the work areas around the pits. Note that gravel from the pits is not taken out and treated but left intact and closed after logging of results.

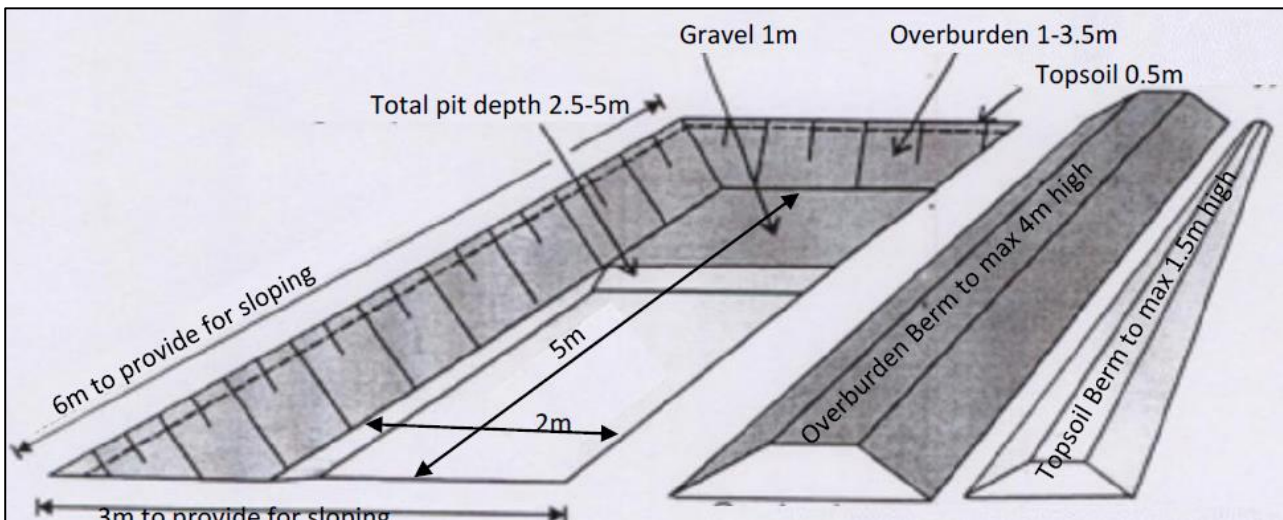

Figure 3: Schematic Pit Development.

LDA (378mm) Exploration Drilling

Drill holes will be positioned at targets identified during Phase 1 where bedrock is between 5 and 10 m below the surface. For each target identified only one hole is required and chip samples from the cyclone will be collected every metre and logging will be done by a geologist who will also record the lithology.

Bulk Sampling

If the results of this preliminary evaluation phase are favourable, the project may move on to the evaluation phase (bulk sampling), where local grades and macro diamond values are established to arrive at a Measured Resource. The excavation and processing of bulk samples however requires a section 20 permission. Bulk sampling is also a separate listing activity under NEMA that require a different EA process and specialised studies that is not possible at this early stage. If this project moves on to the evaluation phase (bulk sampling) it will be done as an extension to the initial prospecting phase in terms of section 102 and is not included as part of this application.

PHASE 3 - Analytical Desktop Studies

The project geologist monitors the program, consolidates, and processes the data and amends the program depending on the results. This is a continuous process throughout the program and

continues even when no prospecting is done on the ground. Each physical phase of prospecting is followed by desktop studies involving interpretation and modelling of all data gathered. These studies will determine the manner in which the work program is to proceed in terms of activity, quantity, resources, expenditure and duration. A GIS based database will be constructed capturing all exploration data.

1.1.2. Identification of alternatives

No alternative sites or methods have been identified as the site is not currently being mined and has been identified as potentially of interest and the methods proposed are the most suitable to achieve the desired outcome.

1.1.3. Aspects of the project relevant to the heritage study

All aspects of the proposed development are relevant, since the drilling may impact on archaeological and/or palaeontological remains, while all above-ground aspects create potential visual (contextual) impacts to the cultural landscape and any significant heritage sites that might be visually sensitive.

1.2. Terms of reference

ASHA Consulting was asked to:

- Describe regional and local features of the receiving environment;
- Conduct a field survey to search for sensitive areas and sites of heritage significance;
- Map sensitive features and provide spatial data;
- Assess the potential impacts on identified heritage resources within a Heritage Impact Assessment (HIA) report;
- Identify relevant legislation and legal requirements; and
- Provide recommendations on possible mitigation measures and management guidelines.

A Notification of Intent to Develop (NID) was previously submitted to Heritage Western Cape (HWC) for any work above the high water mark. HWC responded on 26th June 2023 with the following:

NOTIFICATION OF INTENT TO DEVELOP: PROPOSED PROSPECTING FOR MINERALS ON REMAINDER AND PORTION 1 OF KAROETJIES KOP 150, VANRHYNSDORP, SUBMITTED IN TERMS OF SECTION 38(1) OF THE NATIONAL HERITAGE RESOURCES ACT (ACT 25 OF 1999)

CASE NUMBER: HWC23052609AM0529

The matter above has reference.

Heritage Western Cape is in receipt of your application for the above matter received. This matter was discussed at the Heritage Officers' Meeting (HOMs) Meeting held on 5 June 2023.

You are hereby notified that, since there is reason to believe that the proposed prospecting for minerals on Remainder and Portion 1 of Karoetjies Kop 150, Vanrhynsdorp will impact on heritage resources, HWC requires that a Heritage Impact Assessment (HIA) that satisfies the provisions of Section 38(3) of the NHRA be submitted. Section 38(3) of the NHRA provides

*(3) The responsible heritage resources authority must specify the information to be provided in a report required in terms of subsection (2)(a): **Provided that the following***

must be included:

- (a) *The identification and mapping of all heritage resources in the area affected;*
- (b) *an assessment of the significance of such resources in terms of the heritage assessment criteria set out in section 6(2) or prescribed under section 7;*
- (c) *an assessment of the impact of the development on such heritage resources;*
- (d) *an evaluation of the impact of the development on heritage resources relative to the sustainable social and economic benefits to be derived from the development;*
- (e) *the results of consultation with communities affected by the proposed development and other interested parties regarding the impact of the development on heritage resources;*
- (f) *if heritage resources will be adversely affected by the proposed development, The consideration of alternatives; and*
- (g) *plans for mitigation of any adverse effects during and after the completion of the proposed development.*

(Our emphasis)

This HIA must in addition have specific reference to the following:

- Archaeological Impact Assessment, &
- Palaeontological Impact Assessment.

The HIA must have an overall assessment of the impacts to heritage resources which are not limited to the specific studies referenced above.

The required HIA must have an integrated set of recommendations.

The comments of relevant registered conservation bodies; all Interested and Affected parties; and the relevant Municipality must be requested and included in the HIA where provided. Proof of these requests must be supplied.

1.3. Scope and purpose of the report

A HIA is a means of identifying any significant heritage resources before development begins so that these can be managed in such a way as to allow the development to proceed (if appropriate) without undue impacts to the fragile heritage of South Africa. This HIA report aims to fulfil the requirements of the heritage authorities such that a comment can be issued by them for consideration by the Department of Mineral Resources and Energy (DMRE) who will review the Basic Assessment (BA) and grant or refuse authorisation. The HIA report will outline any management and/or mitigation requirements that will need to be complied with from a heritage point of view and that should be included in the conditions of authorisation should this be granted.

1.4. The author

Dr Jayson Orton has an MA (UCT, 2004) and a D.Phil (Oxford, UK, 2013), both in archaeology, and has been conducting Heritage Impact Assessments and archaeological specialist studies in South Africa (primarily in the Western Cape and Northern Cape provinces) since 2004 (please see curriculum vitae included as Appendix 1). He has also conducted research on aspects of the Later Stone Age in these provinces and published widely on the topic. He is an accredited heritage practitioner with the Association of Professional Heritage Practitioners (APHP; Member #43) and also holds archaeological accreditation with the Association of Southern African Professional Archaeologists (ASAPA) CRM section (Member #233) as follows:

- Principal Investigator: Stone Age, Shell Middens & Grave Relocation; and
- Field Director: Colonial Period & Rock Art.

1.5. Declaration of independence

ASHA Consulting (Pty) Ltd and its consultants have no financial or other interest in the proposed development and will derive no benefits other than fair remuneration for consulting services provided.

2. LEGISLATIVE CONTEXT

2.1. National Heritage Resources Act (NHRA) No. 25 of 1999

The NHRA protects a variety of heritage resources as follows:

- Section 34: structures older than 60 years;
- Section 35: prehistoric and historical material (including ruins) more than 100 years old as well as military remains more than 75 years old, palaeontological material and meteorites;
- Section 36: graves and human remains older than 60 years and located outside of a formal cemetery administered by a local authority; and
- Section 37: public monuments and memorials.

Following Section 2, the definitions applicable to the above protections are as follows:

- Structures: “any building, works, device or other facility made by people and which is fixed to land, and includes any fixtures, fittings and equipment associated therewith”;
- Palaeontological material: “any fossilised remains or fossil trace of animals or plants which lived in the geological past, other than fossil fuels or fossiliferous rock intended for industrial use, and any site which contains such fossilised remains or trace”;
- Archaeological material: a) “material remains resulting from human activity which are in a state of disuse and are in or on land and which are older than 100 years, including artefacts, human and hominid remains and artificial features and structures”; b) “rock art, being any form of painting, engraving or other graphic representation on a fixed rock surface or loose rock or stone, which was executed by human agency and which is older than 100 years, including any area within 10m of such representation”; c) “wrecks, being any vessel or aircraft, or any part thereof, which was wrecked in South Africa, whether on land, in the internal waters, the territorial waters or in the maritime culture zone of the Republic, as defined respectively in sections 3, 4 and 6 of the Maritime Zones Act, 1994 (Act No. 15 of 1994), and any cargo, debris or artefacts found or associated therewith, which is older than 60 years or which SAHRA considers to be worthy of conservation”; and d) “features, structures and artefacts associated with military history which are older than 75 years and the sites on which they are found”;
- Grave: “means a place of interment and includes the contents, headstone or other marker of such a place and any other structure on or associated with such place”; and
- Public monuments and memorials: “all monuments and memorials a) “erected on land belonging to any branch of central, provincial or local government, or on land belonging to any organisation funded by or established in terms of the legislation of such a branch of government”; or b) “which were paid for by public subscription, government funds, or a public-spirited or military organisation, and are on land belonging to any private individual.”

Section 3(3) describes the types of cultural significance that a place or object might have in order to be considered part of the national estate. These are as follows:

- a) its importance in the community, or pattern of South Africa's history;
- b) its possession of uncommon, rare or endangered aspects of South Africa's natural or cultural heritage;
- c) its potential to yield information that will contribute to an understanding of South Africa's natural or cultural heritage;
- d) its importance in demonstrating the principal characteristics of a particular class of South Africa's natural or cultural places or objects;
- e) its importance in exhibiting particular aesthetic characteristics valued by a community or cultural group;
- f) its importance in demonstrating a high degree of creative or technical achievement at a particular period;
- g) its strong or special association with a particular community or cultural group for social, cultural or spiritual reasons;
- h) its strong or special association with the life or work of a person, group or organisation of importance in the history of South Africa; and
- i) sites of significance relating to the history of slavery in South Africa.

While landscapes with cultural significance do not have a dedicated Section in the NHRA, they are protected under the definition of the National Estate (Section 3). Section 3(2)(c) and (d) list "historical settlements and townscapes" and "landscapes and natural features of cultural significance" as part of the National Estate. Furthermore, some of the points in Section 3(3) speak directly to cultural landscapes.

2.2. Approvals and permits

2.2.1. Assessment Phase

Section 38(8) of the NHRA states that if an impact assessment is required under any legislation other than the NHRA then it must include a heritage component that satisfies the requirements of S.38(3). Furthermore, the comments of the relevant heritage authority must be sought and considered by the consenting authority prior to the issuing of a decision. Under the National Environmental Management Act (No. 107 of 1998; NEMA), as amended, the project is subject to a BA. The present report provides the heritage component. HWC is required to provide comment on the proposed project in order to facilitate final decision making by the DMRE.

2.2.2. Construction Phase

If archaeological or palaeontological mitigation is required prior to construction, then the appointed archaeologist or palaeontologist would need to obtain a Workplan approval from HWC. This would be issued in their name. This is so that the heritage authority can ensure that the appointed practitioner has proposed an appropriate methodology that will result in the mitigation being done properly.

2.3. Guidelines

HWC have issued minimum standards documents for HIAs and specialist studies. There is also a Western Cape Provincial guideline for heritage specialists working in an EIA context and which is generally useful. The reporting has been prepared in accordance with these guidelines. The relevant documents are as follows:

- Heritage Western Cape. 2016. Grading: purpose and management implications.
- Heritage Western Cape. 2019. Public consultation guidelines.
- Heritage Western Cape. 2021. Guide for Minimum Standards for Archaeology and Palaeontology reports submitted to Heritage Western Cape.
- Heritage Western Cape. 2021. Notification of Intent to Develop, Heritage Impact Assessment, (Pre-Application) Basic Assessment Reports, Scoping Reports and Environmental Impact Assessments, Guidelines for submission to Heritage Western Cape.
- Winter, S. & Baumann, N. 2005. Guideline for involving heritage specialists in EIA processes: Edition 1. CSIR Report No ENV-S-C 2005 053 E. Republic of South Africa, Provincial Government of the Western Cape, Department of Environmental Affairs & Development Planning, Cape Town.

2.4. Application timeline

The application to the DMRE under NEMA is currently in the application phase with submission estimated to be around late July 2023.

3. METHODS

3.1. Literature survey and information sources

A survey of available literature was carried out to assess the general heritage context into which the development would be set. The information sources used in this report are presented in Table 1 with relevant dates of each source referenced in the text as needed. Data were also collected via a field survey. The data quality is suitable for the purpose of informing this report.

Table 1: Information sources used in this assessment.

Data / Information	Source	Date	Type	Description
Maps	Chief Directorate: National Geo-Spatial Information	Various	Spatial	Historical and current 1:50 000 topographic maps of the study area and immediate surrounds
Aerial photographs	Chief Directorate: National Geo-Spatial Information	Various	Spatial	Historical aerial photography of the study area and immediate surrounds
Aerial photographs	Google Earth	Various	Spatial	Recent and historical aerial photography of the study area and immediate surrounds
Cadastral data	CapeFarmMapper (http://gis.elsenburg.com/apps/cfm/#)	Current	Spatial	Cadastral boundaries, extents and aerial photography

Cadastral data	Chief Directorate: National Geo-Spatial Information	Various	Survey diagrams	Historical and current survey diagrams, property survey and registration dates
Background data	South African Heritage Resources Information System (SAHRIS)	Various	Reports	Previous impact assessments for any developments in the vicinity of the study area
Palaeontological sensitivity	South African Heritage Resources Information System (SAHRIS)	Current	Spatial	Map showing palaeontological sensitivity and required actions based on the sensitivity.
Background data	Books, journals, websites	Various	Books, journals, websites	Historical and current literature describing the study area and any relevant aspects of cultural heritage.

3.2. Field survey

The site was subjected to a detailed foot survey on 1st, 4th and 5th June 2023, with an earlier survey on 27th March 2023 also covering part of the study area. This was during Autumn and early Winter but, in this dry area, the season makes no meaningful difference to vegetation covering and hence the ground visibility for the archaeological survey. Other heritage resources are not affected by seasonality. During the survey the positions of finds and survey tracks were recorded on a hand-held Garmin Global Positioning System (GPS) receiver set to the WGS84 datum (Figure 4). Photographs were taken at times in order to capture representative samples of both the affected heritage and the landscape setting of the proposed development.

It should be noted that the amount of time between the dates of the field inspection and final report do not materially affect the outcome of the report.



Figure 4: Aerial view of the study area (green polygon) showing the accumulated survey tracks (white lines).

3.3. Specialist studies

A specialist palaeontological study was carried out by John Pether. It is included in full as Appendix 3 of this HIA. The specialist archaeological study is included within the body of the HIA. The specialist maritime archaeological study was compiled by Vanessa Maitland and appears as Appendix 4 in this HIA.

3.4. Grading

S.7(1) of the NHRA provides for the grading of heritage resources into those of National (Grade I), Provincial (Grade II) and Local (Grade III) significance. Grading is intended to allow for the identification of the appropriate level of management for any given heritage resource. Grade I and II resources are intended to be managed by the national and provincial heritage resources authorities respectively, while Grade III resources would be managed by the relevant local planning authority. These bodies are responsible for grading, but anyone may make recommendations for grading.

It is intended under S.7(2) that the various provincial authorities formulate a system for the further detailed grading of heritage resources of local significance but this is generally yet to happen. Heritage Western Cape (2016), however, uses a system in which resources of local significance are divided into Grade IIIA, IIIB and IIIC. These approximately equate to high, medium and low local significance, while sites of very low or no significance (and generally not requiring mitigation or other interventions) are referred to as Not Conservation Worthy (NCW).

3.5. Consultation

The draft HIA was submitted to relevant interested and affected parties as required by HWC in their response to the NID application (Section 1.2). The report was also included in the main public participation process (PPP) required under NEMA as part of the BA.

3.6. Assumptions and limitations

The field study was carried out at the surface only and hence any completely buried archaeological sites would not be readily located. Similarly, it is not always possible to determine the depth of archaeological material visible at the surface.

4. PHYSICAL ENVIRONMENTAL CONTEXT

4.1. Site context

The site is in a very remote location and is served only by relatively informal gravel roads. Although one primary road runs all along the coast, many smaller tracks have been developed through the illegal use of off-road vehicles to access the beach and drive on the dunes. The site lies a short distance north of the Sout River which is used for salt production, while to the south again is the existing Tronox Namakwa Sands Mine. The surrounding farms are all used for small stock grazing. Diamond prospecting has already been undertaken in various areas of the local coastline and old prospecting trenches are commonly seen.

4.2. Site description

The site is generally quite flat and slopes very gently downhill towards the coast in the southwest. The main exception is a small river valley (Ratelgat se Holte) that bisects the study area, while along the immediate coast there are differences in gradient depending on the presence of bedrock or sand dunes. Vegetation is largely about ankle- to knee-high, but rarely plants up to waist-high do occur. The substrate throughout is sandy, although bedrock occasionally protruded close to the coast. Figures 4 to 11 illustrate the study area from north to south.



Figure 4: Looking southeast from near the north-western end of the study area.



Figure 5: Looking northwest showing a granite outcrop away from the coastline.



Figure 6: Looking south across one of the small sandy bays along the northern coastline of the study area.



Figure 7: Looking southeast along one of the larger sandy beaches in the centre of the study area.



Figure 8: Looking southwest along the small stream bed (pale sand in mid-picture) of the Ratelgat se Holte.



Figure 9: Looking south over the sandy beach at the mouth of the Ratelgat se Holte.



Figure 10: Looking southeast in the southern part of the study area showing the vegetation covering near the inland boundary of the study area.



Figure 11: Looking northwest along the southernmost sandy beach in the study area showing sporadic rock outcrops in the surf zone and the small coastal dunes.

5. FINDINGS OF THE HERITAGE STUDY

This section describes the heritage resources recorded in the study area during the course of the project. Table 2 lists all the sites recorded during the survey. They are mapped in Appendix 2.

5.1. Palaeontology

The SAHRIS Palaeosensitivity Map shows the site to be of variable palaeontological sensitivity. Most is very high, but sections along the coast are rated as low or unknown (Figure 12). For this reason, an independent palaeontological study was commissioned. John Pether (2023) found that a variety of geological formations are present in the study area, though all are covered at the surface by the aeolian sands of the Koekenaap Formation away from the coast or the Witzand Formation (recent dunes) close to the coast. The Curlew Strand Formation (raised beach deposits) are also occasionally exposed close to the beach. Pether notes that the high sensitivity relates to the Koekenaap Formation and is primarily due to the fossil bones and shells that occur within it and in fact largely at its base where they rest on the hard palaeosurface of the Dorbank Formation. He notes this material to often be associated with archaeological artefacts.

More common fossils from the area that may be intersected by drilling include the bones of tortoises, molerats, marine shells, shark and other fish teeth and casts of shells (steinkerns). However, bones and teeth of larger animals may also occur, but are very rare. The raised beach deposits of the Curlew Strand Formation will also be intersected by the proposed prospecting but these are comprised largely of extant taxa and are thus less important. It is notable, however, that the bones of marine mammals and birds may also be present within the raised beaches and these are of greater importance but are rare (Pether 2023).

Pether (2023) considers the potential impacts to fossils as being of low significance due to the scarcity of fossils and low likelihood of actually intersecting them.

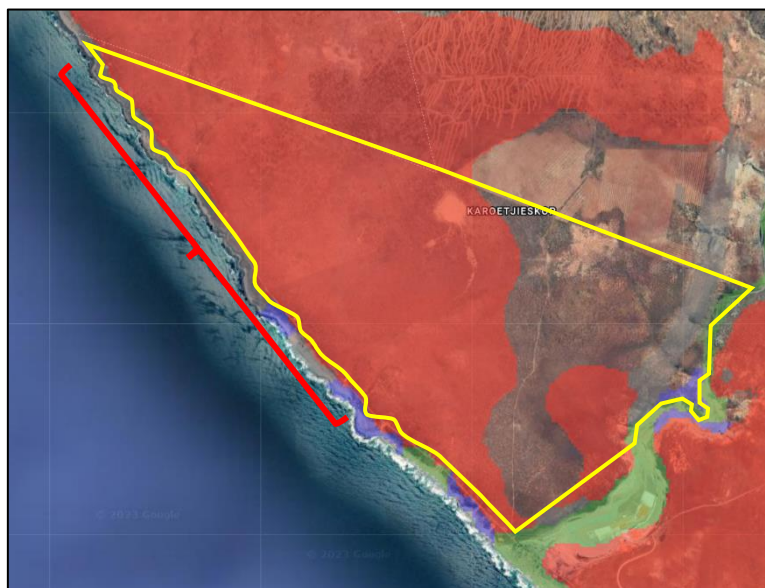

Figure 12: Extract from the SAHRIS Palaeosensitivity Map showing the study area (indicated by red brace) to be of very high sensitivity (red shading) with sections of low (blue) and unknown sensitivity (clear) along the immediate coastline.

Table 2: List of finds made during the survey. Mitigation is indicated regardless of impact, but in this instance no sites are at risk mitigation other than avoidance will not be required.

Way-point	Location	Density	Dimension 1	Dimension 2	C. granatina	S. granularis	S. argenvillei	S. barbara	S. cochlear	C. meridionalis	A. ater	Burnupena sp.	A. pustulosum	Oxystelesp.	Quartz	Quartzite	Silcrete	Quartz porphyry	Manuports	Ostrich eggshell	Pottery	Kreef	Bone	Comments	Grade	
853	S31 09 23.1 E17 45 54.0	L	8	8	x	x	x																	Very fragmented	NCW	
854	S31 09 22.5 E17 45 53.5	L	40	30	x	x	x	x																Less fragmented towards the west.	IIIC	
855	S31 09 21.5 E17 45 53.4																									
856	S31 09 21.0 E17 45 52.6	L	10	10	x	x	x																	Very fragmented	NCW	
857	S31 09 20.2 E17 45 53.6														x		x		x					ESA/MSA exposure	NCW	
858	S31 09 18.8 E17 45 54.2	M	100	20	x	x	x								x					x						IIIC
859	S31 09 20.7 E17 45 56.9																									
860	S31 09 21.5 E17 45 59.4	M/D	40	20	x	x	x			x	x													Two dense scatters of 10 m each. Site is among taller vegetation.	IIIC	
861	S31 09 22.4 E17 45 59.5																									
862	S31 09 23.3 E17 45 59.3	L	10	10	x	x	x																		IIIC	
863	S31 09 23.6 E17 46 00.2	L	10	20	x	x	x	x																	IIIC	
864	S31 09 21.6 E17 45 55.9		1.5	2																				A small, modern cement floor slab	n/a	
865	S31 09 18.9 E17 45 55.9	?	?	?	x	x	x																	Shell revealed in burrowed sand only.	IIIC	
866	S31 09 18.3 E17 45 55.1	M	20	20	x	x	x																		IIIC	
867	S31 09 17.8 E17 45 57.6	L	10	10	x	x	x																		IIIC	
868	S31 09 15.9 E17 45 55.7	E	10	10	x	x	x																	Very fragmented	NCW	
869	S31 09 13.2 E17 45 52.4	E	10	20	x	x																			NCW	

Way-point	Location	Density	Dimension 1	Dimension 2	C. granatina	S. granularis	S. argenvillei	S. barbara	S. cochlear	C. meridionalis	A. ater	Burnupena sp.	A. pustulosum	Oxysteles sp.	Quartz	Quartzite	Silcrete	Quartz porphyry	Manuports	Ostrich eggshell	Pottery	Kreef	Bone	Comments	Grade	
870	S31 09 12.4 E17 45 51.0	L	15	30	x	x	x								x				x							IIIC
871	S31 09 12.7 E17 45 49.9																									
872	S31 09 13.3 E17 45 49.6																									
873	S31 09 12.0 E17 45 46.7	L	20	20	x	x	x												x							IIIC
874	S31 09 13.6 E17 45 47.9	M	20	20	x	x	x																			IIIC
875	S31 09 14.8 E17 45 47.7	D	15	15	x	x	x													x					Much shell is revealed in a burrow and suggests the subsurface is likely a dense scatter.	IIIC
876	S31 09 15.4 E17 45 49.8	L	10	10	x	x	x					x							x							IIIC
877	S31 09 15.2 E17 45 50.9	M	20	?	x	x	x												x						Shell revealed in side of a trench. Seems to originate about 0.6 m below the surface.	IIIC
878	S31 09 14.4 E17 45 50.4	M	15	?	x	x	x												x						Shell revealed in side of a trench. Seems to originate about 0.3 m below the surface.	IIIC
879	S31 09 15.2 E17 45 52.2	M	10	10	x	x	x																			IIIC
880	S31 09 16.7 E17 45 52.7	M	15	20	x	x	x									x									Located on a rise.	IIIC
881	S31 09 16.9 E17 45 51.5	M	15	15	x	x	x												x						Also has a UG/HS and an HS.	IIIC
882	S31 09 17.2 E17 45 49.5	M	10	10	x	x	x					x						x							Very fragmented, located in jeep track.	NCW
883	S31 09 16.8 E17 45 48.3	L	3	3	x	x																				NCW
884	S31 09 15.0 E17 45 46.9	L	15	15	x	x	x					x			x				x							IIIC
885	S31 09 05.5 E17 45 38.1	L	20	20	x	x	x					x			x										Lots of Burnupena.	IIIC

Way-point	Location	Density	Dimension 1	Dimension 2	C. granatina	S. granularis	S. argenvillei	S. barbara	S. cochlear	C. meridionalis	A. ater	Burnupena sp.	A. pustulosum	Oxystelesp.	Quartz	Quartzite	Silcrete	Quartz porphyry	Manuports	Ostrich eggshell	Pottery	Kreef	Bone	Comments	Grade	
891	S31 09 03.2 E17 45 34.2	E	80	20	x	x	x																	Extensive ephemeral scatter parallel to the shoreline.	NCW	
892	S31 09 01.5 E17 45 32.6																									
886	S31 09 06.4 E17 45 36.9	L/M	730	80	x	x	x					x		x	x	x									Extensive, continuous shell scatter parallel to the shoreline. Some burrows and human excavations in this scatter revealed subsurface shell that suggests some areas of higher density beneath the surface.	IIIC
887	S31 09 06.2 E17 45 35.9																									
888	S31 09 11.4 E17 45 39.8																									
889	S31 09 10.3 E17 45 41.7																									
890	S31 09 07.4 E17 45 39.4																									
893	S31 09 12.4 E17 45 41.3																									
894	S31 09 12.1 E17 45 43.2																									
895	S31 09 14.4 E17 45 42.8																									
896	S31 09 14.7 E17 45 45.5																									
897	S31 09 15.9 E17 45 46.9																									
898	S31 09 16.6 E17 45 44.6																									
899	S31 09 17.1 E17 45 46.6																									
900	S31 09 18.8 E17 45 47.0																									
901	S31 09 18.8 E17 45 49.3																									
902	S31 09 20.5 E17 45 48.7																									
903	S31 09 21.2 E17 45 50.2																									
904	S31 09 22.7 E17 45 50.1																									

Way-point	Location	Density	Dimension 1	Dimension 2	C. granatina	S. granularis	S. argenvillei	S. barbara	S. cochlear	C. meridionalis	A. ater	Burnupena sp.	A. pustulosum	Oxysteie sp.	Quartz	Quartzite	Silcrete	Quartz porphyry	Manuports	Ostrich eggshell	Pottery	Kreef	Bone	Comments	Grade
905	S31 09 23.9 E17 45 51.1																								
906	S31 09 25.0 E17 45 50.8																								
907	S31 09 25.5 E17 45 53.3	L	10	10	x	x	x																		IIIC
908	S31 09 26.4 E17 45 52.0	L	15	15	x	x																			IIIC
909	S31 09 27.0 E17 45 50.1	M	20	30	x	x	x							x										There is a bedrock outcrop to the southwest and the site lies on the flat platform behind this outcrop.	IIIC
910	S31 09 30.7 E17 45 51.3	M	20	30	x	x	x							x				x	x				x	Bone is a whale bone fragment.	IIIC
915	S31 09 29.2 E17 45 55.7		1.5	2																				Modern cement floor	n/a
919	S31 09 32.6 E17 45 52.1	E	10	10	x	x	x																		NCW
920	S31 09 34.4 E17 45 50.3	2	4																					Modern cement floor and two stone fireplaces	n/a
911	S31 09 30.3 E17 45 53.8	L/M	240	90	x	x	x					x		x			x		x	x			x	One burnt bone fragment seen. There is a rubbish dump (mostly glass bottles) on the scatter at waypoint 914.	IIIC
912	S31 09 31.0 E17 45 54.9																								
913	S31 09 31.5 E17 45 55.9																								
914	S31 09 29.4 E17 45 54.5																								
916	S31 09 30.7 E17 45 55.6																								
917	S31 09 31.7 E17 45 56.8																								
918	S31 09 32.6 E17 45 56.8																								
921	S31 09 33.0 E17 45 58.2																								
922	S31 09 31.3 E17 45 57.7																								

Way-point	Location	Density	Dimension 1	Dimension 2	C. granatina	S. granularis	S. argenvillei	S. barbara	S. cochlear	C. meridionalis	A. ater	Burnupena sp.	A. pustulosum	Oxystelesp.	Quartz	Quartzite	Silcrete	Quartz porphyry	Manuports	Ostrich eggshell	Pottery	Kreef	Bone	Comments	Grade	
923	S31 09 30.4 E17 45 56.7																									
924	S31 09 29.7 E17 45 58.4																									
925	S31 09 29.1 E17 45 58.4																									
926	S31 09 29.4 E17 45 59.3																									
927	S31 09 30.4 E17 45 59.1																									
928	S31 09 31.8 E17 45 58.6																									
929	S31 09 33.5 E17 45 58.8																									
930	S31 09 34.1 E17 45 58.7																									
931	S31 09 33.6 E17 46 00.1																									
932	S31 09 34.6 E17 45 58.7																									
933	S31 09 35.3 E17 46 00.0																									
934	S31 09 36.5 E17 46 00.7	E	10	10	x	x	x													x					NCW	
935	S31 09 41.3 E17 46 00.5	L	50	15	x	x	x																		The scatter merges with the storm beach shell to the southwest. There are also some bottles and modern ceramics on this site.	NCW
936	S31 09 42.7 E17 46 01.3																									
937	S31 09 41.8 E17 46 05.2	L	15	35	x	x	x																		IIC	
938	S31 09 41.0 E17 46 04.6	L	15	45	x	x	x							x						x					IIC	
939	S31 09 41.0 E17 46 03.3																									
940	S31 09 41.4 E17 46 02.9																									

Way-point	Location	Density	Dimension 1	Dimension 2	C. granatina	S. granularis	S. argenvillei	S. barbara	S. cochlear	C. meridionalis	A. ater	Burnupena sp.	A. pustulosum	Oxysteles sp.	Quartz	Quartzite	Silcrete	Quartz porphyry	Manuports	Ostrich eggshell	Pottery	Kreef	Bone	Comments	Grade
941	S31 09 37.9 E17 46 01.4	E	5	5	x	x	x					x													NCW
942	S31 09 37.9 E17 46 03.1	L	15	15	x	x	x					x										x			IIC
943	S31 09 39.4 E17 46 04.0	M	20	20	x	x	x	x												x					IIC
944	S31 09 42.9 E17 46 08.3	?	15	?	x	x	x					x		x										Revealed in the wall of a trench. Shell seems to originate about 0.5 m below the surface.	IIC
945	S31 09 43.9 E17 46 08.8	M	20	20	x	x	x													x				An OES flask was buried here with the opening just level with the ground. The opening is in the side of the shell and the shell is undecorated. Many other OES fragments but no second aperture was seen.	IIC
946	S31 09 44.4 E17 46 04.8	E	5	5	x	x	x																		NCW
947	S31 09 46.7 E17 46 09.1	E	10	20	x	x	x																		NCW
948	S31 10 06.1 E17 46 22.1	E	20	20	x	x	x																		NCW
949	S31 09 55.6 E17 46 22.8	E	10	10	x	x	x																		NCW
950	S31 09 55.2 E17 46 21.5	E	10	10	x	x	x							x											NCW
951	S31 09 54.6 E17 46 18.4	L	20	30	x	x	x																	There is an ostrich nest on the site so any work would have to stay well clear of it to avoid modern OES.	IIC
952	S31 09 54.0 E17 46 17.6	L-D	30	50	x	x	x								x									Five moderate to dense shell patches in a large area of low density shell scatter.	IIC
953	S31 09 54.3 E17 46 17.1																								

Way-point	Location	Density	Dimension 1	Dimension 2	C. granatina	S. granularis	S. argenvillei	S. barbara	S. cochlear	C. meridionalis	A. ater	Burnupena sp.	A. pustulosum	Oxystelesp.	Quartz	Quartzite	Silcrete	Quartz porphyry	Manuports	Ostrich eggshell	Pottery	Kreef	Bone	Comments	Grade
954	S31 09 53.7 E17 46 16.9																								
955	S31 09 53.1 E17 46 17.2																								
956	S31 09 52.8 E17 46 16.7																								
957	S31 09 48.8 E17 46 16.2	L	30	30	x	x	x																		IIIC
958	S31 09 49.3 E17 46 15.1	E	15	15	x	x	x														x				NCW
959	S31 09 44.8 E17 46 11.4	E	20	20	x	x	x	x				x													NCW
960	S31 09 41.5 E17 46 09.0	M	10	20	x	x	x												x					It is possible that this site is a topsoil pile from the trench but it seems unlikely given the adjacent sites in similar context.	IIIC
961	S31 09 40.5 E17 46 08.2	L	30	30	x	x	x							x											IIIC
962	S31 09 39.9 E17 46 07.2	L	20	20	x	x	x												x						IIIC
963	S31 09 36.4 E17 46 06.0	L	30	30	x	x	x							x											IIIC
964	S31 09 37.2 E17 46 05.8																								
965	S31 09 35.4 E17 46 05.0																								
966	S31 09 31.1 E17 46 05.3	L	10	15	x	x	x																		NCW
967	S31 09 34.2 E17 46 03.2	L	10	25	x	x	x																		IIIC
968	S31 09 34.4 E17 46 02.5																								
969	S31 09 33.9 E17 46 02.0	M/D	10	20	x	x	x																	Two dense scatters of 3-5 m in a wider scatter of moderate density.	IIIC
970	S31 09 33.6 E17 46 01.9																								

Way-point	Location	Density	Dimension 1	Dimension 2	C. granatina	S. granularis	S. argenvillei	S. barbara	S. cochlear	C. meridionalis	A. ater	Burnupena sp.	A. pustulosum	Oxysteles sp.	Quartz	Quartzite	Silcrete	Quartz porphyry	Manuports	Ostrich eggshell	Pottery	Kreef	Bone	Comments	Grade	
971	S31 09 31.0 E17 46 01.9	E	15	15	x	x																			NCW	
972	S31 09 32.1 E17 46 01.0	L	20	20	x	x	x					x			x			x			x				Pottery is ochred on the outside.	IIIC
973	S31 09 31.7 E17 46 01.4																									
974	S31 09 31.6 E17 46 00.9																									
975	S31 09 29.0 E17 46 01.3	L	20	20	x	x	x												x						IIIC	
976	S31 09 28.7 E17 46 03.4	E	50	50	x	x	x																		No focus for the shell.	NCW
977	S31 09 26.1 E17 46 05.1	E	20	20	x	x	x																			NCW
978	S31 09 25.6 E17 46 01.1	E	20	20	x	x	x																			NCW
979	S31 09 25.1 E17 46 00.3	L	10	10	x	x	x																			IIIC
980	S31 09 27.0 E17 45 59.7	L	15	15	x	x	x							x												IIIC
981	S31 09 27.9 E17 45 59.6	D	10	20	x	x	x					x														IIIC
982	S31 09 27.6 E17 45 58.7	L	10	15	x	x	x							x	x										Most shell is revealed in a burrow, but the surface scatter extends about 15 m NE from the burrow.	IIIC
983	S31 09 25.0 E17 45 56.7	L/D	20	20	x	x	x					x	x					x							There is a dense scatter at 983 that is 3x6 m.	IIIC
984	S31 09 24.3 E17 45 56.4																									
985	S31 09 24.2 E17 45 54.7	L	5	5	x	x	x																			NCW
986	S31 09 59.5 E17 46 20.3	M	10	10	x	x	x																			IIIC
987	S31 10 00.3 E17 46 21.7	E	10	10	x	x	x																			NCW
988	S31 10 01.9 E17 46 22.7	E	15	15	x	x	x																			NCW

Way-point	Location	Density	Dimension 1	Dimension 2	C. granatina	S. granularis	S. argenvillei	S. barbara	S. cochlear	C. meridionalis	A. ater	Burnupena sp.	A. pustulosum	Oxysteles sp.	Quartz	Quartzite	Silcrete	Quartz porphyry	Manuports	Ostrich eggshell	Pottery	Kreef	Bone	Comments	Grade
989	S31 10 13.9 E17 46 28.2	E	5	5	x	x	x																		NCW
990	S31 10 12.8 E17 46 29.0	L	10	10	x	x	x																		IIIC
991	S31 10 10.6 E17 46 28.2	M	20	20	x	x	x																	Mostly very fragmented but some larger/whole shell has been brought up in burrows showing better shell below the surface.	IIIC
992	S31 10 09.9 E17 46 27.6	L	20	50	x	x	x													x	x			Pottery is a rim sherd that is plain, rounded and slightly everted.	IIIC
993	S31 10 09.0 E17 46 27.0																								
994	S31 10 08.3 E17 46 27.3																								
995	S31 10 07.6 E17 46 25.8	L	20	20	x	x	x					x													IIIC
996	S31 10 09.1 E17 46 29.0	E	5	5	x	x	x																		NCW
997	S31 10 09.7 E17 46 29.2	L	20	20	x	x	x					x													IIIC
998	S31 10 14.3 E17 46 31.5	L	20	50	x	x	x		x																IIIC
999	S31 10 15.6 E17 46 31.2																								
1000	S31 10 16.7 E17 46 34.4	D	30	30	x	x	x							x									x		IIIC
1001	S31 10 17.4 E17 46 36.0	E	8	8	x	x	x																		NCW
1002	S31 10 20.3 E17 46 39.6	E	8	8	x	x	x																		NCW
1003	S31 10 25.4 E17 46 54.2	E	5	5	x	x	x																		NCW
1004	S31 10 32.0 E17 46 55.3	L	15	15	x	x						x												On side of river valley. May well have shell going into the slope.	IIIC
1005	S31 10 33.8 E17 46 55.5	E	5	5	x	x	x							x										Several quartz artefacts seen here.	NCW

Way-point	Location	Density	Dimension 1	Dimension 2	C. granatina	S. granularis	S. argenvillei	S. barbara	S. cochlear	C. meridionalis	A. ater	Burnupena sp.	A. pustulosum	Oxysteles sp.	Quartz	Quartzite	Silcrete	Quartz porphyry	Manuports	Ostrich eggshell	Pottery	Kreef	Bone	Comments	Grade	
1006	S31 10 33.8 E17 46 52.8	E	10	10	x	x	x					x			x											NCW
1007	S31 10 33.2 E17 46 51.2	E	15	15	c	c	c			c																NCW
1008	S31 10 48.8 E17 47 04.0	L	10	10	x	x	x								x											IIIC
1009	S31 10 59.1 E17 47 14.2	E	5	5	x	x	x																			NCW
1010	S31 11 00.4 E17 47 14.7	L	10	10	x	x	x								x											IIIC
1011	S31 11 02.0 E17 47 15.7	L	10	30	x	x	x								x											IIIC
1012	S31 11 09.0 E17 47 23.6	M\D	30	30	x	x	x	x				x								x					Small dense area in the middle of the larger scatter.	IIIC
1013	S31 11 08.2 E17 47 23.5	L	10	20	x	x	x								x											IIC
1014	S31 11 05.4 E17 47 22.8	L	20	40	x	x	x																			IIIC
1015	S31 11 04.4 E17 47 22.2																									
1016	S31 11 02.3 E17 47 20.2	E	5	5	x	x	x																			NCW
1017	S31 10 56.4 E17 47 16.6	E	5	5	x		x																			NCW
1018	S31 10 51.1 E17 47 14.7	L	15	15	x	x	x																			IIIC
1126	S31 11 50.3 E17 47 54.2	E	20	40	x	x	x	x							x											NCW
1127	S31 11 49.9 E17 47 53.2																									
1128	S31 11 49.0 E17 47 51.6	E	30	30	x	x	x																			NCW
1129	S31 11 50.5 E17 47 51.7	E	15	15	x	x	x																			NCW
1130	S31 11 51.5 E17 47 51.6	E	20	20	x	x	x																			NCW
1131	S31 11 51.7 E17 47 50.6	L	30	30	x	x	x			x															Also some small moderate shell patches.	IIIC

Way-point	Location	Density	Dimension 1	Dimension 2	C. granatina	S. granularis	S. argenvillei	S. barbara	S. cochlear	C. meridionalis	A. ater	Burnupena sp.	A. pustulosum	Oxysteles sp.	Quartz	Quartzite	Silcrete	Quartz porphyry	Manuports	Ostrich eggshell	Pottery	Kreef	Bone	Comments	Grade	
1132	S31 11 52.7 E17 47 50.5	D	5	10	x	x	x																	Two dense patches a few meters apart.	IIIC	
1133	S31 11 53.0 E17 47 50.0	D	5	10	x	x	x																	Two dense patches a few meters apart.	IIIC	
1134	S31 11 51.0 E17 47 49.1	D	5	8	x	x	x					x														IIIC
1135	S31 11 51.1 E17 47 49.8	L	8	8	x	x	x																			IIIC
1136	S31 11 50.3 E17 47 50.1	E	10	10	x	x	x													x						NCW
1137	S31 11 50.0 E17 47 50.6	E	10	10	x	x	x																			NCW
1138	S31 11 48.4 E17 47 51.0	E	10	10	x	x	x													x						NCW
1139	S31 11 47.5 E17 47 52.0	E	10	10	x	x	x													x						NCW
1140	S31 11 46.3 E17 47 52.7	E	10	10	x	x	x																			NCW
1141	S31 11 46.7 E17 47 50.7	E	10	10	x	x	x							x												NCW
1142	S31 11 47.1 E17 47 50.1	E	10	10	x	x	x																			NCW
1143	S31 11 49.4 E17 47 49.2	L	15	15	x	x	x							x												IIIC
1144	S31 11 50.4 E17 47 47.6	M	10	10	x	x	x																			IIIC
1145	S31 11 47.0 E17 47 48.5	L	10	10	x	x	x																			IIIC
1146	S31 11 45.7 E17 47 49.2	E	10	10	x	x	x																			NCW
1147	S31 11 45.2 E17 47 49.7	E	10	10	x	x	x																			NCW
1148	S31 11 44.8 E17 47 48.1	L	15	15	x	x	x																			IIIC
1149	S31 11 39.8 E17 47 46.0	E	15	15	x	x	x																			NCW
1150	S31 11 42.1 E17 47 45.5	E	10	10	x	x	x																			NCW

Way-point	Location	Density	Dimension 1	Dimension 2	C. granatina	S. granularis	S. argenvillei	S. barbara	S. cochlear	C. meridionalis	A. ater	Burnupena sp.	A. pustulosum	Oxysteles sp.	Quartz	Quartzite	Silcrete	Quartz porphyry	Manuports	Ostrich eggshell	Pottery	Kreef	Bone	Comments	Grade	
1151	S31 11 44.4 E17 47 44.0	E	15	15	x	x	x					x												Also one <i>Bullia</i> seen.	NCW	
1152	S31 11 45.1 E17 47 43.0	L	20	50	x	x	x	x				x													Light scatter but also shell in mole heaps all over the area suggesting subsurface deposits.	IIIC
1153	S31 11 46.4 E17 47 43.3																									
1154	S31 11 43.4 E17 47 43.0	L	20	20	x	x	x								x											IIIC
1155	S31 11 36.5 E17 47 45.3	E	15	15	x	x	x																			NCW
1156	S31 11 34.5 E17 47 44.0	E	10	10	x	x	x																			NCW
1157	S31 11 25.7 E17 47 40.0	E	?	?	x	x	x																		This (and 1158) represents a widespread ephemeral scatter with no focus that stretches for a few hundred meters.	NCW
1158	S31 11 19.9 E17 47 35.7	E	10	10	x	x	x																		Essentially a slightly denser area of the 1157 scatter, but still ephemeral.	NCW
1159	S31 11 11.3 E17 47 29.9	E	10	10	x	x																				NCW
1160	S31 11 07.5 E17 47 25.3	L	10	50	x	x	x																			IIIC
1161	S31 11 08.7 E17 47 26.2																									
1162	S31 11 10.1 E17 47 23.8	E	10	10	x	x	x								x											NCW
1163	S31 11 11.4 E17 47 21.6	E	10	10	x	x	x																			NCW
1164	S31 11 12.6 E17 47 22.8	E	20	20	x	x	x																			NCW
1165	S31 11 12.2 E17 47 26.1	L	15	15	x	x	x								x											IIIC
1166	S31 11 12.3 E17 47 27.7	L	30	30	x	x	x																	x		IIIC

Way-point	Location	Density	Dimension 1	Dimension 2	C. granatina	S. granularis	S. argenvillei	S. barbara	S. cochlear	C. meridionalis	A. ater	Burnupena sp.	A. pustulosum	Oxysteles sp.	Quartz	Quartzite	Silcrete	Quartz porphyry	Manuports	Ostrich eggshell	Pottery	Kreef	Bone	Comments	Grade
1167	S31 11 15.2 E17 47 29.7	E	15	15	x	x	x								x					x					NCW
1168	S31 11 16.2 E17 47 29.5	E	10	10	x	x																			NCW
1169	S31 11 15.2 E17 47 27.0	E	10	10	x	x						x			x										NCW
1170	S31 11 22.5 E17 47 30.6	L	20	150	x	x	x								x										IIIC
1171	S31 11 26.2 E17 47 33.9																								
1172	S31 11 22.7 E17 47 33.3	E	20	20	x	x	x																		NCW
1173	S31 11 23.2 E17 47 35.3	E	15	15	x	x	x																		NCW
1174	S31 11 26.9 E17 47 37.6	E	10	10	x	x	x								x										NCW
1175	S31 11 28.3 E17 47 37.9	E	10	10	x	x	x	x											x						NCW
1176	S31 11 29.0 E17 47 38.4	E	15	15	x	x	x																		NCW
1177	S31 11 29.7 E17 47 38.5	E	10	10	x	x	x																		NCW
1178	S31 11 30.8 E17 47 38.5	E	10	10	x	x	x																		NCW
1179	S31 11 32.0 E17 47 37.5	L	5	5	x	x	x																		IIIC
1180	S31 11 30.2 E17 47 40.8	E	15	15	x	x	x																		NCW
1181	S31 11 33.6 E17 47 40.1	L	20	20	x	x	x								x										IIIC
1182	S31 11 34.7 E17 47 40.3	E	10	10	x	x	x								x										NCW
1183	S31 11 34.8 E17 47 42.0	E	10	10	x	x	x								x										NCW
1184	S31 11 51.2 E17 47 59.0	E	20	20	x	x	x																		NCW
1185	S31 11 53.7 E17 48 02.1	E	10	10	x	x				x															NCW

Way-point	Location	Density	Dimension 1	Dimension 2	C. granatina	S. granularis	S. argenvillei	S. barbara	S. cochlear	C. meridionalis	A. ater	Burnupena sp.	A. pustulosum	Oxysteles sp.	Quartz	Quartzite	Silcrete	Quartz porphyry	Manuports	Ostrich eggshell	Pottery	Kreef	Bone	Comments	Grade		
1186	S31 11 51.1 E17 47 55.7	E	5	5	x	x	x																	Shells revealed in burrow so there may be more dense material beneath the surface.	NCW		
1187	S31 11 51.6 E17 47 55.1	L	10	15	x	x	x													x						IIIC	
1188	S31 11 51.3 E17 47 53.7	L	15	15	x	x	x																			IIIC	
1189	S31 11 52.1 E17 47 53.4	E	5	5	x	x	x																			NCW	
1190	S31 11 52.9 E17 47 53.6	L	5	5	x	x	x					x	x													IIIC	
1191	S31 11 53.3 E17 47 53.2	L	5	10	x	x	x							x												IIIC	
1192	S31 11 53.6 E17 47 52.6	L	20	20	x	x	x					x								x		x				IIIC	
1193	S31 11 52.4 E17 47 51.1	D/L	15	15	x	x	x			x		x		x											Small dense scatter in the centre of a wider light scatter.	IIIC	
1194	S31 11 53.1 E17 47 51.3	D	10	10	x	x	x			x								x							Lots of shell in a burrow so subsurface deposits present.	IIIC	
1195	S31 11 54.1 E17 47 50.8	E	5	5	x	x	x																			NCW	
1196	S31 11 55.5 E17 47 51.4	L	5	10	x	x	x			x		x														IIIC	
1197	S31 11 49.4 E17 47 44.8	L	40	50	x	x	x								x										Most shell is in mole heaps. The scatter seems to merge with storm beach shell to the southwest.	IIIC	
1198	S31 11 49.7 E17 47 43.7																										
1199	S31 11 48.5 E17 47 43.5																										
1200	S31 11 46.9 E17 47 43.1	L	10	10	x	x	x					x													Most shell was visible in mole heaps.	IIIC	
1201	S31 11 45.3 E17 47 42.1																								These points lies on a wide bank of Holocene-aged storm beach shell that is higher than the land immediately inland	NCW	
1206	S31 11 51.1 E17 47 43.4																										

Way-point	Location	Density	Dimension 1	Dimension 2	C. granatina	S. granularis	S. argenvillei	S. barbara	S. cochlear	C. meridionalis	A. ater	Burnupena sp.	A. pustulosum	Oxystelesp.	Quartz	Quartzite	Silcrete	Quartz porphyry	Manuports	Ostrich eggshell	Pottery	Kreef	Bone	Comments	Grade		
																								of it. In places there may be some archaeological shell on top of it.			
1202	S31 11 41.9 E17 47 42.7	L	5	5	x	x	x																			IIIC	
1203	S31 11 39.9 E17 47 43.4	L	15	15	x	x	x																				IIIC
1204	S31 11 37.8 E17 47 43.4	L	10	20	x	x	x																				IIIC
1205	S31 11 37.0 E17 47 42.4	E	15	15	x	x	x																				NCW
1207	S31 11 54.2 E17 47 46.2	L	10	30	x	x	x																				IIIC
1208	S31 11 55.1 E17 47 46.3																										
1209	S31 11 55.6 E17 47 46.8																										
1210	S31 11 56.6 E17 47 48.0	L	10	10	x	x	x																				IIIC
1211	S31 11 57.5 E17 47 48.8	L	15	15x	x	x							x														IIIC
1212	S31 12 03.1 E17 47 53.6																										NCW
1213	S31 12 02.5 E17 47 56.1	L	5	5	x	x	x			x		x															IIIC
1214	S31 12 12.9 E17 48 12.5	L	?	?	x	x								x													NCW

Way-point	Location	Density	Dimension 1	Dimension 2	C. granatina	S. granularis	S. argenvillei	S. barbara	S. cochlear	C. meridionalis	A. ater	Burnupena sp.	A. pustulosum	Oxysteles sp.	Quartz	Quartzite	Silcrete	Quartz porphyry	Manuports	Ostrich eggshell	Pottery	Kreef	Bone	Comments	Grade	
																								extends beyond the churned area.		
1215	S31 12 21.2 E17 48 17.9	E	5	10	x	x	x					x			x				x							NCW
1216	S31 12 23.3 E17 48 19.8	L	10	20	x	x	x								x				x							IIIC
1217	S31 12 24.8 E17 48 22.4	E	10	10	x	x	x					x			x											NCW
1218	S31 12 08.2 E17 48 10.7	E	10	10	x	x				x																NCW
1219	S31 12 03.9 E17 48 09.2	?	?	?	x	x	x			x															Shell only revealed in a burrow, nothing on the surface.	IIIC
1220	S31 11 57.6 E17 47 57.0	E	10	10	x	x						x														NCW
1221	S31 11 56.1 E17 47 51.7	L	10	?	x	x	x																		Revealed in a track but not on the surface.	IIIC
1222	S31 11 52.9 E17 47 55.6	E	10	10	x	x	x																			NCW
1223	S31 11 52.2 E17 47 55.9	E	10	10	x	x	x																			NCW
1224	S31 11 51.4 E17 47 56.3	L/D	15	15	x	x	x																		Small dense scatter of 5 m diameter in the middle of the wider light scatter.	IIIC
1225	S31 11 53.2 E17 47 56.4	L	10	10	x	x	x								x											IIIC
1226	S31 11 54.3 E17 47 56.1	E	15	15	x	x	x																			NCW
1227	S31 11 55.3 E17 47 55.3	E	10	10	x	x	x					x														NCW
1228	S31 11 55.9 E17 47 56.3	E/D	10	20	x	x	x	x		x		x													Two dense patches in an area of 5 m by 10 m within the larger ephemeral scatter.	IIIC
1229	S31 11 56.9 E17 47 56.6	M/D	10	10	x	x	x			x		x													Two patches of moderate and dense scatter very close together.	IIIC

Way-point	Location	Density	Dimension 1	Dimension 2	C. granatina	S. granularis	S. argenvillei	S. barbara	S. cochlear	C. meridionalis	A. ater	Burnupena sp.	A. pustulosum	Oxystelesp.	Quartz	Quartzite	Silcrete	Quartz porphyry	Manuports	Ostrich eggshell	Pottery	Kreef	Bone	Comments	Grade		
1230	S31 11 57.9 E17 47 59.4	E	15	15	x	x	x																	Also a packed stone and cement (pieces of an old building) feature with three 5 m arms and a 1 m gap in the middle.	NCW		
1231	S31 11 59.4 E17 48 00.9	L	5	5	x	x	x			x																IIIC	
1232	S31 11 59.9 E17 48 00.7	L	10	10	x	x	x																			IIIC	
1233	S31 12 00.4 E17 48 00.6	D	5	5	x	x	x					x											x			IIIC	
1234	S31 11 55.6 E17 47 57.5	L	35	35	x	x	x																			IIIC	
1235	S31 11 54.7 E17 47 57.7																										
1236	S31 11 55.2 E17 47 58.2																										
1237	S31 11 55.7 E17 48 00.4	L	10	10	x	x	x																			IIIC	
1238	S31 11 54.3 E17 47 59.3																										
1239	S31 11 53.4 E17 47 58.1	E	3	3	x	x		x							x											NCW	
1240	S31 12 32.5 E17 48 29.5	E	20	20	x	x	x																			NCW	
1241	S31 12 33.5 E17 48 30.8	L	10	20	x	x	x					x														IIIC	
1242	S31 12 38.4 E17 48 33.7	?	?	?	x	x	x								x										There are shells and quartz artefacts exposed in narrow gullies between sand dunes here at least 2 m below their crests. Impossible to know the extent of material present.	IIIC	
1243	S31 12 43.5 E17 48 40.3	M	20	20	x	x	x																			IIIC	

Way-point	Location	Density	Dimension 1	Dimension 2	C. granatina	S. granularis	S. argenvillei	S. barbara	S. cochlear	C. meridionalis	A. ater	Burnupena sp.	A. pustulosum	Oxystelesp.	Quartz	Quartzite	Silcrete	Quartz porphyry	Manuports	Ostrich eggshell	Pottery	Kreef	Bone	Comments	Grade		
1244	S31 12 44.1 E17 48 42.3	L	15	100	x	x	x	x							x									There is a dense patch at waypoint 1248.	IIIC		
1245	S31 12 44.9 E17 48 44.4																										
1246	S31 12 46.1 E17 48 45.3																										
1247	S31 12 46.8 E17 48 46.4																										
1248	S31 12 47.3 E17 48 46.7																										
1249	S31 12 48.2 E17 48 46.9																										
1250	S31 12 48.6 E17 48 48.1	L	15	30	x	x	x					x			x									Very fragmented.	IIIC		
1251	S31 12 49.2 E17 48 48.2	M	10	10	x	x	x																		IIIC		
1252	S31 12 50.1 E17 48 49.4	D	15	15	x	x	x	x		x		x			x				x						IIIC		
1253	S31 12 51.6 E17 48 50.6	D	15	20	x	x	x	x		x			x		x				x						IIIC		
1254	S31 12 52.1 E17 48 50.2	M	5	5	x	x	x								x									Also a rifle cartridge here but it might be a later intrusion.	IIIC		
1255	S31 12 52.9 E17 48 50.0	M	5	10	x	x	x																		IIIC		
1256	S31 12 52.3 E17 48 51.9	L/M/ D	70	70	x	x	x			x		x			x										There is a large shell midden here along the crest of a dune. The shell runs down the seaward side of the dune as well and reduces in density there. Much of the site has been destroyed by off-road vehicles but sections of the dune crest remain intact.	IIIC	
1257	S31 12 52.9 E17 48 53.5																										
1258	S31 12 54.3 E17 48 55.8	L	10	20	x	x	x																		IIIC		

Way-point	Location	Density	Dimension 1	Dimension 2	C. granatina	S. granularis	S. argenvillei	S. barbara	S. cochlear	C. meridionalis	A. ater	Burnupena sp.	A. pustulosum	Oxysteles sp.	Quartz	Quartzite	Silcrete	Quartz porphyry	Manuports	Ostrich eggshell	Pottery	Kreef	Bone	Comments	Grade
1260	S31 12 52.3 E17 48 54.6	E	5	5	x	x						x													NCW
1261	S31 12 49.2 E17 48 51.1	E	10	30	x	x						x			x										NCW
1262	S31 12 47.0 E17 48 49.8	E	10	10	x	x				x															NCW
1263	S31 12 41.6 E17 48 38.5	M	15	15	x	x	x					x												Very fragmented.	IIIC
1264	S31 12 40.7 E17 48 37.3	E	10	10	x	x	x		x																NCW
1265	S31 12 38.2 E17 48 35.7	E	5	15	x	x	x																		NCW

5.2. Archaeology

5.2.1. Desktop study

All three Stone Ages are represented in the archaeological record of Namaqualand. Early Stone Age (ESA) stone artefacts, including the well-known Acheulean hand-axes and cleavers, are generally known from deflated or eroding areas throughout the region from the Richtersveld in the north to the Knersvlakte in the south and along the entire coastal stretch (Orton & Webley 2009; Halkett 2002a, 2006; Morris, 2004; Morris & Webley 2004; Orton & Halkett 2004; Halkett 2000a). These are usually isolated occurrences in secondary contexts, although sizeable scatters of ESA material have been located at Kleinsee, some 180 km north-northwest of Karoetjies Kop (Halkett 2002a), and in the Namakwa Sands Mine just to the southeast of Karoetjies Kop (Orton 2017a, 2022, in prep.). Along the coast here they accumulate on the hardpan deposits which underlie the sand dunes. A good scatter of ESA artefacts is also known from the Knersvlakte, some 70 km to the east-southeast (Orton, personal observation). One ESA artefact scatter and quarry site surrounding a silcrete outcrop was excavated in the Namakwa Sands Mine area (Hart & Halkett 1994) just south of the present study area.

Middle Stone Age (MSA) material is also widespread. Significant known sites include Spitzkloof in the Richtersveld (Dewar & Stewart 2012, 2017), sites with bifacial points from near Koingnaas (Halkett & Orton 2005) and from the Knersvlakte (Mackay *et al.* 2010) and the collapsed rock shelter deposit at VR003 (Steele *et al.* 2012, 2016). Rare and significant MSA sites containing shell and bone have been reported from the southern half of the Namaqualand coast (Halkett 2000b, 2001; Halkett *et al.* 1993; Hart & Halkett 1999), while a few other MSA sites are known from further north (Dewar 2008). One MSA occurrence has been excavated in the Namakwa Sands Mine (Halkett *et al.* 1993). Throughout the southern parts of the Namaqualand Sandveld MSA artefacts are found in areas where the unconsolidated sands have been removed (Hart 2007; Orton 2010a, personal observation). The artefacts have deflated downwards and collected on the harder layer beneath along with ESA materials. MSA finds from such a context have recently been sampled by Orton (in prep.).

Later Stone Age (LSA) sites are abundant throughout Namaqualand, particularly in areas close to the coast. Many surveys in the coastal region have revealed thousands of shell middens and scatters in various contexts including sand dunes, deflation hollows, cliff tops and in open, flat areas (Halkett 2000a, 2000b, 2002b, 2006, 2019; Halkett & Hart 1997; Hart 1999, 2003, 2007; Orton 2010b, 2010c, 2017a, 2017c, 2022; Orton & Halkett 2004; Orton & Webley 2012a, 2012b; Patrick & Manhire 2014; Parkington & Poggenpoel 1991; Van der Ryst *et al.* 2021). Sites with reasonable amounts of shell on them can be found as far as 10 km inland, although an extensive survey in an area some 12 km southeast of Karoetjies Kop showed that shell density dropped off rapidly anywhere between about 0.5 km and 1 km inland with areas further inland having virtually no shell visible. Significantly, however, Van der Ryst *et al.* (2021) found several shell scatters further inland in the low-lying basin known as Die Kom and located east of the ridge that forms the eastern edge of the current Graauw Duinen study area. Recent excavations there have shown the shell to be lower in density than at coastal sites (Orton in prep.). The density of archaeology in the coastal zone is also quite variable with Halkett's (2019) mapping illustrating this well. LSA sites include a wider variety of finds than earlier sites because their younger age means that preservation is better. Such finds include stone artefacts, bone tools, ostrich eggshell beads and water flask fragments, pottery and food waste

including animal bones, rock lobster mandibles and, of course, large quantities of shellfish. These sites offer excellent opportunities to explore and better understand the recent pre-colonial history of the area with certain richer sites being particularly informative (e.g. Dewar 2008; Dewar *et al.* 2004; Orton 2012, 2014). More ephemeral sites also have a story to tell because they might relate to a particular time period or segment of an annual migration cycle that is not recorded at larger sites (Orton 2007c). A peculiar aspect of the Namaqualand LSA record is the presence of deliberately buried tortoises at some sites. The animals were cooked and eaten and the bones were then buried in small pits. This appears to have happened at the start of occupation and is thought by Orton (2012b) to have been a consecration ritual of some sort. These burials are all dated within the last 800 years.

Archaeological work already carried out at Brand-se-Baai has resulted in the recording of many archaeological sites in the region. Some of these have been salvaged prior to mining but others have been lost, mainly in the inland areas. Several shell middens have been excavated from along the coastal strip (Halkett *et al.* 1993), while other sites from further inland have also been sampled (Hart & Halkett 1994; Hart & Lanham 1997; Orton 2015a, 2015b, 2015c, 2017b, in prep.). As expected, all the radiocarbon dates obtained on the LSA sites date to the latter half of the Holocene mirroring the pattern evident on the northern part of the coast (Orton 2012). It is surprising, however, that only two post-date 2000 years ago – such recent dates are dominant elsewhere. The oldest date from the area was obtained from a deflation hollow site, HBK2014/015, and showed occupation around 4500 BC (Orton 2015d).

Further inland LSA archaeological material is usually found associated with landscape features such as river valleys, deflation hollows, or rocky outcrops where these are present. Only one very rich deflation hollow has been located in Namaqualand and this was close to Kleinzee in the north (Orton 2007b). Near Elands Bay to the south of Namaqualand there are large numbers of hollows preserving much archaeological material (Manhire 1987a, 1987b). Along the Buffels River, near Kleinzee, Orton (2007b) excavated several hollows containing light traces of recent occupation – most sites had pottery demonstrating an age of less than 2000 years. None of these was particularly significant. In southern Namaqualand most recorded deflation hollows contain rather ephemeral artefact scatters (Hart 2007; Hart & Halkett 1994; Hart & Orton 2005), but in the Namakwa Sands East Mine several hollows have been found to contain very important sites. Further inland, the Knersvlakte has revealed a few LSA sites in rock shelters and in the open. Most are along the Varsche River valley (Orton 2012, 2018; Orton *et al.* 2011).

Rock art occurs in various parts of Namaqualand (Morris & Webley 2004; Rudner & Rudner 1968; Webley 1984; Orton 2013) with the nearest to the study area being in a valley some 17 km inland of Brand-se-baai (Orton 2012, 2013). Two painted sites exist on the north bank of the Oliphants River, southwest of Koekenaap, with the larger one once having contained an extremely significant archaeological deposit that has now been all but destroyed (Orton 2012, 2013).

Pre-colonial burials occur all over South Africa but are particularly frequently encountered in coastal dune systems, no doubt because of the soft sand that was easy to excavate by hand. Most burials are discovered accidentally during the course of development and are therefore wholly or partly disturbed without a proper record being made. Only one burial has been discovered in Namaqualand during archaeological excavations and this one, near Kleinzee, revealed grave goods in the form of an ostrich eggshell bead bracelet, two *Conus* shells (often used as decorative items) and a bone melon knife (Orton 2007a). None have yet been reported from the southern

Namaqualand coast, although one burial whose precise location is unknown has been found in the area (Morris 1992).

Although the extensive work carried out along the northern Namaqualand coastline has allowed a relatively robust cultural sequence to be described there (Dewar 2008; Orton2012), this sequence is very different to that documented to the south of Namaqualand. As a result, the intervening area is important because we do not yet know where the archaeological signature changes and why it does this. The region is critical to the understanding of the spread of domestic stock within the last 2000 years (Orton 2012) and more observations from southern Namaqualand may help to answer questions still remaining. The suite of known observations from the Brand-se-Baai area has yet to be incorporated into the broader archaeological record for the region.

One of the most important sites discovered at Namakwa Sands to the south of Karoetjies Kop is HK11, a small rock shelter site in the eastern part of the mine. This site has an extensive talus slope and contains a wide variety of archaeological materials (Hart & Orton 2007). It has yet to be excavated, but is protected within a no-go zone. Another important site is RFE2014/007. This site lies atop a dune ridge, also in the East Mine, and was found to contain many European trade goods including well more than 700 glass trade beads. Just seven glass beads had been recovered from the Namaqualand coastline before this site was excavated (Orton 2012, 2014). The excavation covered a few hundred square meters and has shown very strong spatial patterning. A third significant site is HBK2015/015 which contained a very spectacular mid-Holocene-aged stone artefact assemblage with large numbers of retouched tools (Orton 2015a).

5.2.2. Site visit

The archaeological sites recorded during the survey include mostly LSA materials, but some ESA finds – and probably some MSA – were also made. The oldest material is of Pleistocene age and rests upon the dorbank layer beneath the red aeolian sands. It is revealed in places where the sand has blown away after disturbance, either along the coastal road, around the margins of prospecting pits or in areas where natural erosion has exposed the harder layer. Figures 13 to 15 shows one of these areas. It is quite likely that some of the artefacts exposed on these deflated surfaces are in fact from the MSA but, in the absence of diagnostic materials, this cannot be confirmed. Handaxes, where present, are diagnostic ESA artefacts though (Figure 15; this scatter was reported in Orton [2023]). Very few such exposures were seen in the study area but the low density scatter is known to continue beneath the recent sand cover.

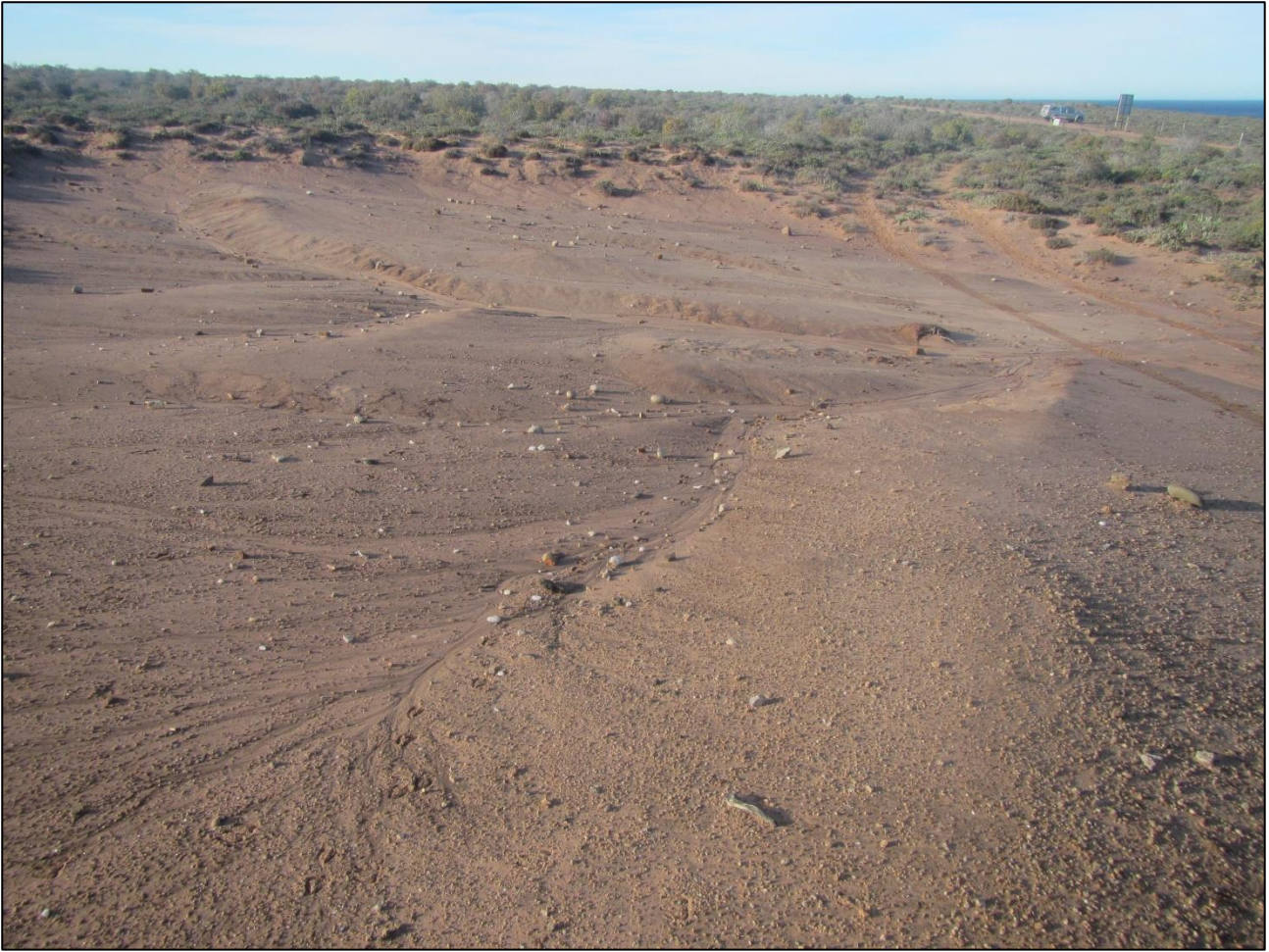

Figure 13: Exposed hardpan with ephemeral flaked artefacts and other stones on it in a previously disturbed area at waypoint 857.



Figure 14: Exposed hardpan with ephemeral flaked artefacts and other stones on it along the coastal road at waypoint 754.

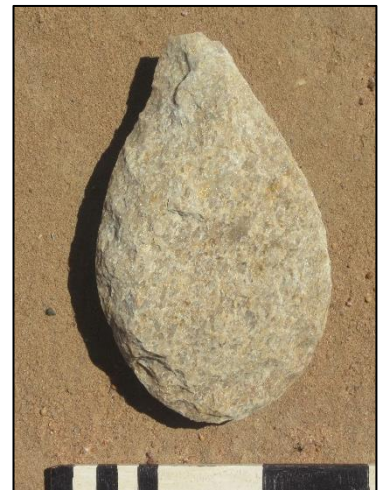

Figure 15: Handaxe at waypoint 754.

The remaining Stone Age sites are all Holocene-aged LSA shell scatters and shell middens. A number of sites were seen exposed in the coastal road cuttings to the south of the study area and in the sides of old prospecting trenches within the study area. These indicate that some sites are

completely buried under more recent aeolian sand deposits. Figure 16 shows a typical example, while Figure 17 shows a dense shell accumulation revealed by a burrow. This latter shows that a dense shell scatter is likely present beneath the surface in this area.



Figure 16: Shells revealed in section along the edge of an old prospecting trench at waypoint 877.



Figure 17: Dense shell revealed in a burrow at waypoint 875 suggesting dense buried shell.

Elsewhere, large numbers of shell scatters were seen with these varying from dense to ephemeral. Most sites were located on red sand with the white dunes tending to have fewer sites. Figures 18 to 23 show the nature and variability of these sites. The finding of an intact ostrich eggshell flask at waypoint 945 was of interest (Figures 21 & 22). It was buried shallow enough to be revealed at the surface and, unusually, its opening, which faced up, was on the side of the shell instead of on the narrow end. A few sites were located on white sand. Figure 24 shows an example and also shows the damage caused by the illegal use of off-road vehicles in the coastal dunes.



Figure 18: Dense shell scatter at waypoint 953.



Figure 19: Moderate density shell scatter at waypoint 880. Scale in 1 cm and 5 cm intervals.



Figure 20: Moderate density shell scatter at waypoint 945. A largely buried ostrich eggshell flask was found here.



Figure 21: Ostrich eggshell flask at waypoint 945 as found but with a small amount of sand scraped away just to confirm the find. Scale in 1 and 5 cm intervals.



Figure 22: The ostrich eggshell flask from waypoint 945 with its opening on the side of the egg. Scale in 1 and 5 cm intervals.



Figure 23: Low density shell at waypoint 961.



Figure 24: Shell midden deposits on a white coastal dune ridge behind the beach at waypoint 1256.

Figure 25 and 26 show examples of finds associated with these shell scatters. Included was a water worn *Conus mozambicus* shell. These shells were collected from the beach as decorative items rather than for food. Isolated stone artefacts were occasionally seen on the surface in a few places and are considered to be background scatter. These latter items are of no further concern.



Figure 25: Pottery and stone artefacts from waypoint 972. Scale in 1 and 5 cm intervals.



Figure 26: A water worn *Conus* shell at waypoint 1039. Scale in 1 and 5 cm intervals.

In the eastern part of the farm is the farmstead which is called Peddie-se-Kop. It contains the remains of two structures as well as four standing structures in variable condition. All have been reported on in Orton (2023) and, because they are far from the project area (4.8 km northeast of the south-eastern end of the prospecting right boundary), they are not discussed again here. It is noted, however, that none of the features is close to the edge of the farm road through the complex so even if this road were used for access there would be no impacts.

5.3. Maritime heritage

The maritime archaeology assessment shows that a number of ships could potentially be wrecked in the area but, due to very limited information about most of them, the chances of encountering any are very low (Maitland 2023). While most wrecks are probably in the water, there is a chance of finding lifeboat debris or even graves of drowned sailors on land. Most ships are not culturally significant but potentially more significant ones would include the older ones, wartime losses and certain others with specific (and potentially unknown) reasons for higher significance.

5.4. Graves

No graves were seen during the survey, but one grave has been documented to the southwest of the farmhouse (Halkett 2000a¹). This is far from the impact area and of no further concern. The archaeological desktop study noted the rarity of human remains from southern Namaqualand but, nonetheless, it remains a possibility that unmarked precolonial human burials or even the graves of sailors (Maitland 2023) may be present beneath the surface anywhere in the study area.

5.5. Historical aspects and the Built environment

5.5.1. Desktop study

This part of Namaqualand is very remote and bears few historical features and/or structures. Hart and Orton (2006) located a historical house in an old farm complex that was perhaps from the 1930s, while Orton (2017c) found similar-aged structures on a near-coastal farm further to the south. Some features at both these complexes suggested possible origins in the 19th century. The majority of houses and other farm buildings in the general area tend to be 20th century in age (personal observation). Farmsteads tend to be very widely spaced in the coastal zone, likely due to the very limited resources present and difficulty of access in the past.

Historical aerial photography can inform on some of the history of a place. The 1942 image shows that there were agricultural lands adjacent to a large patch of exposed hardpan to the northwest of the farmstead. There is barely any trace of these ploughed lands on modern aerial photography showing that they have long since fallen into disuse. A small dam that lies to the west looks as though it may have been a natural pan in the past. The current main house is not present in 1942, while the structure to its southeast is clearly visible. The ruins mentioned above, however, cannot be seen, possibly indicating that they were already in ruin. Interestingly, all the farm tracks present today seem to have already been in use by 1942. These features are discussed at greater length in Orton (2023) and are of no further relevance here.

¹ The co-ordinates provided lie at the coast so the exact location of the grave is unknown.

Mining in the area is relatively recent with the 1964 topographic map not showing any such features along the coast. The 1942 aerial photography shows that the coastal road was not yet there, and no prospecting can be seen. By 1958 a small track runs along near the coast but is not the modern coastal road. Prospecting still appears to be absent from the landscape. By 1966 the coastal road is still absent but a number of prospecting trenches are visible. The 1976 aerial photography shows these prospecting trenches and the modern coastal road.

5.5.2. Site visit

Aside from all the farm tracks which are more than 80 years old, the only historical resource on the farm is the Peddie-se-kop farmstead at waypoint 742. The archaeological aspects have been mentioned above but three standing structures are also present. Two are older and in relatively poor shape. One is a barn/outbuilding which was likely once a house as it has a hearth-and-chimney stack attached to it. It has a corrugated iron roof and cement-plastered walls and it stands on a stone plinth. The other structure is a small two-roomed cottage made of sundried mudbricks and plastered with cement. It has a corrugated iron roof and wooden joinery and also stands on a stone plinth. A small buttress supports one corner of the house. These structures have been reported on more fully in Orton (2023). The farmstead will not be affected by the proposed development and is thus of no further relevance.

5.6. Cultural landscapes and scenic routes

Cultural landscapes are the product of the interactions between humans and nature in a particular area. Sauer (1925) defined them thus: “The cultural landscape is fashioned from a natural landscape by a cultural group. Culture is the agent, the natural area is the medium, the cultural landscape the result”.

The cultural landscape of the study area is largely a natural landscape with minimal anthropogenic intervention. It is organic in nature having changed over the years, perhaps based on climate. It is evident that agriculture was practised on the farm during the mid-20th century (as noted above) but no sign of this remains today with the vegetation having recovered, assisted perhaps by the strong southerly winds that move sand across the surface. As already noted, all the farm tracks, including one track close to and parallel with the coast, are historic and form part of the cultural landscape. Only the main coastal road and myriad tracks between it and the coast are new, the latter having been created by modern campers with off-road vehicles.

Namaqualand is well-known for its remoteness. The study area is typical of much of the Namaqualand coastline and is an area frequented by campers (along the public coastal zone). The landscape certainly has scenic value but has been disturbed by prospecting activities over the last 60 years which have left trenches open and unrehabilitated. Mining is very much an entrenched part of the Namaqualand landscape. Winter and Oberholzer (2013) identify the Sout River estuary as having scenic value at the local level, although it is noted here that it has been heavily compromised by its long history of commercial salt production. The Namaqua National Park lies to the north but its southernmost edge is some 36 km northwest of the study area and the park is thus not a concern.

The study area is far from any major public roads with the coastal track generally being an infrequently used public access. In summer many campers descend on the coastline and leave

significant quantities of rubbish. The coastal area has been damaged by illegal off-road vehicle activities and numerous camping areas have been constructed (platforms and fireplaces). These detract from the wilderness qualities of the area. There are thus no scenic route concerns.

5.7. Statement of significance and provisional grading

Section 38(3)(b) of the NHRA requires an assessment of the significance of all heritage resources. In terms of Section 2(vi), “cultural significance” means aesthetic, architectural, historical, scientific, social, spiritual, linguistic or technological value or significance. The reasons that a place may have cultural significance are outlined in Section 3(3) of the NHRA (see Section 2 above).

The palaeontological resources are deemed to have up to medium-high cultural significance at the local level for their scientific value and can be graded up to IIIB or even IIIA. Finds of these grades are expected to be extremely rare and their locations cannot be predicted. The majority of finds, however, are of lower significance and can be graded IIIC or NCW.

The archaeological resources are deemed to have low cultural significance at the local level for their scientific value and can be graded IIIC. Many sites, however, are of even lower significance and can be graded NCW. It should be noted that these grades are based on surface observations and there is a high likelihood that more significant materials may lie buried beneath the surface. Nonetheless, from experience in the wider area, grades above IIIB are not expected.

Graves are deemed to have high cultural significance at the local level for their social value. They are allocated a grade of IIIA.

The cultural landscape is largely a natural landscape with aesthetic value and is rated as having medium cultural significance at the local level. It can be graded IIIB.

Figures 27 to 32 show the locations of all significant sites within the properties concerned. Note that the proposed project layout cannot be shown as the locations of prospecting pits and drilling will only be determined during the first phase of the project.

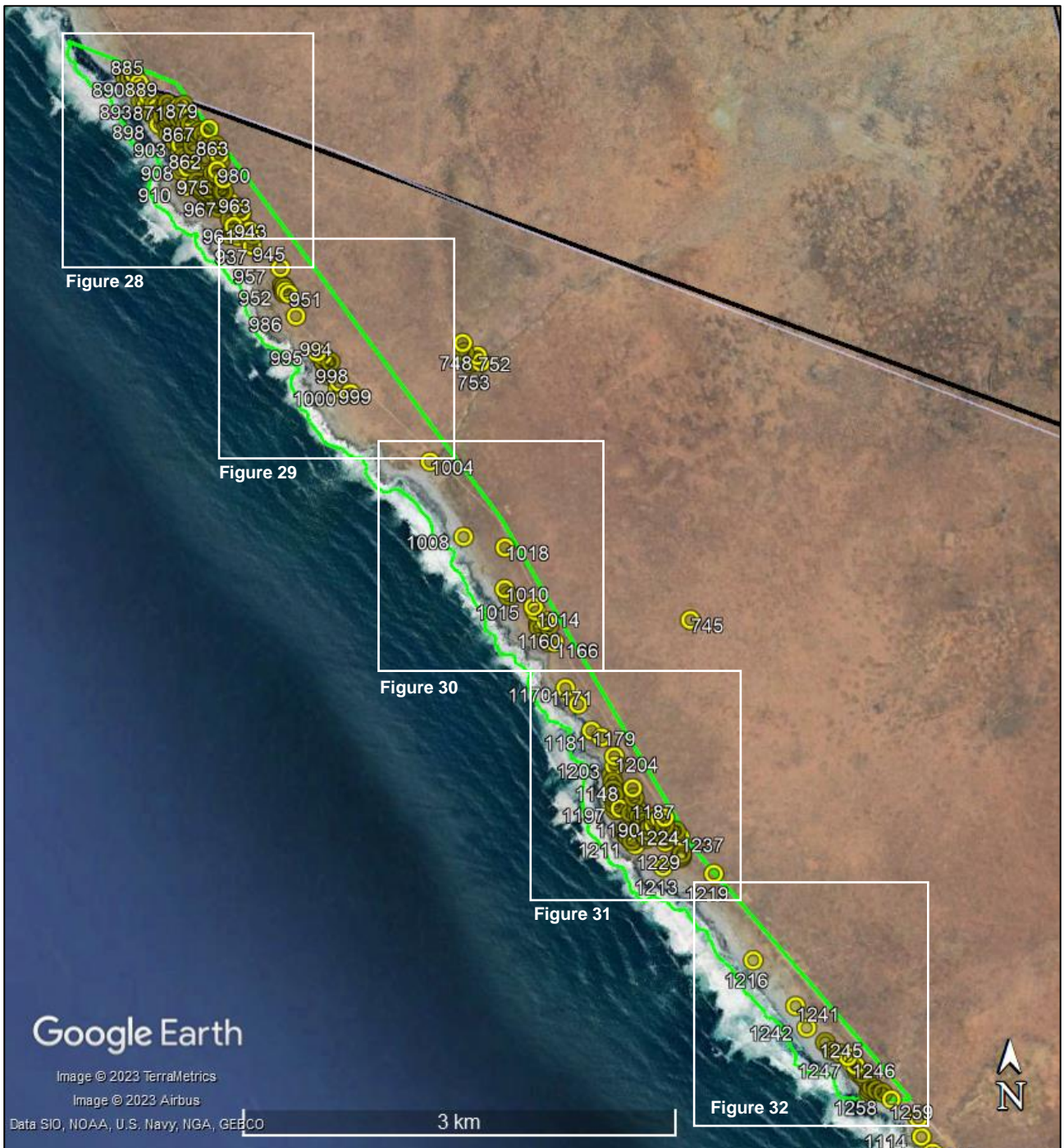

Figure 27: Aerial view of the Karoetjies Kop area showing the locations of all significant heritage resources on the properties concerned. In this and the subsequent maps, yellow are Grade IIIC. NCW sites are not shown. All buffers are 50 m.

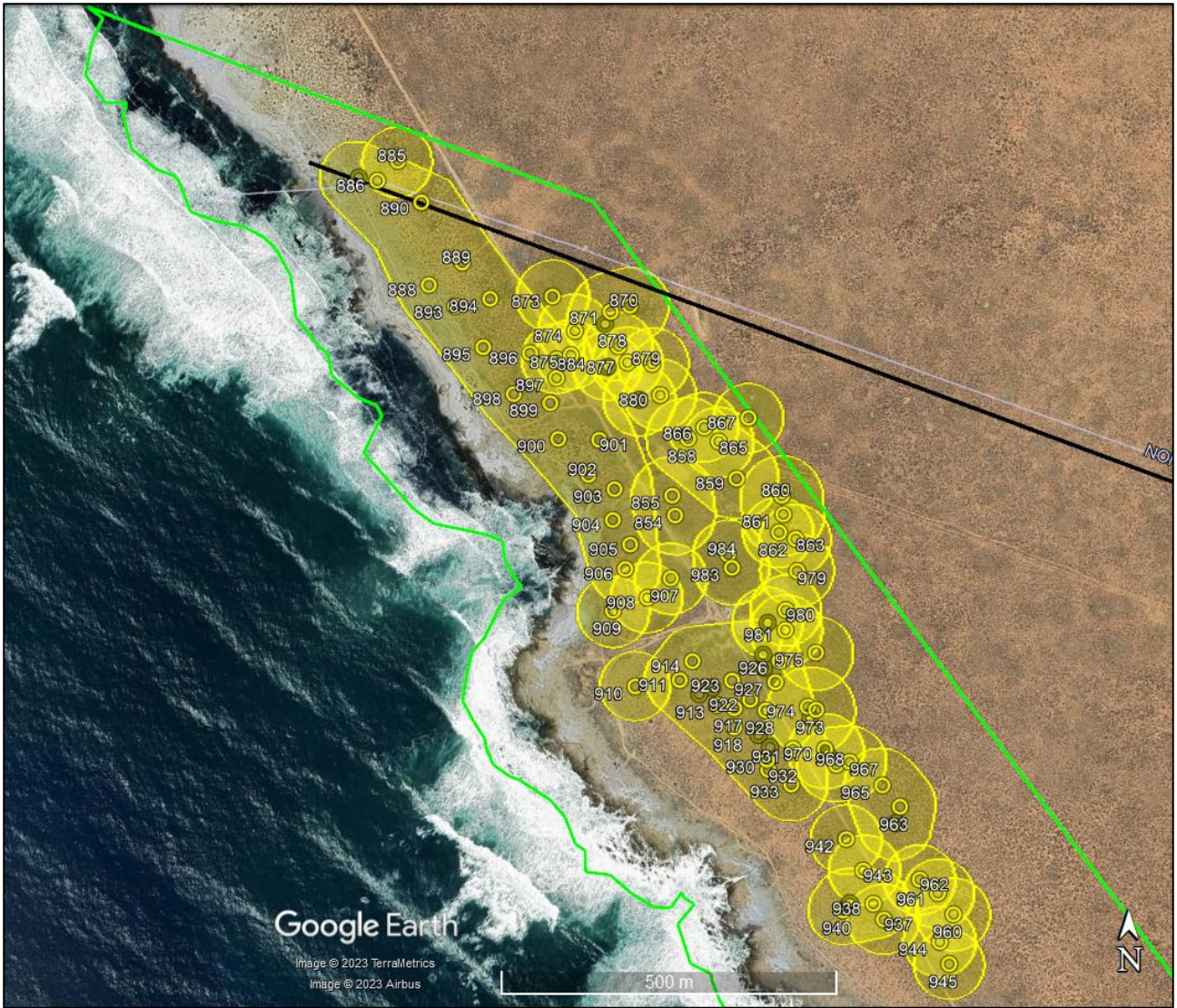

Figure 28: Enlargement from Figure 27.

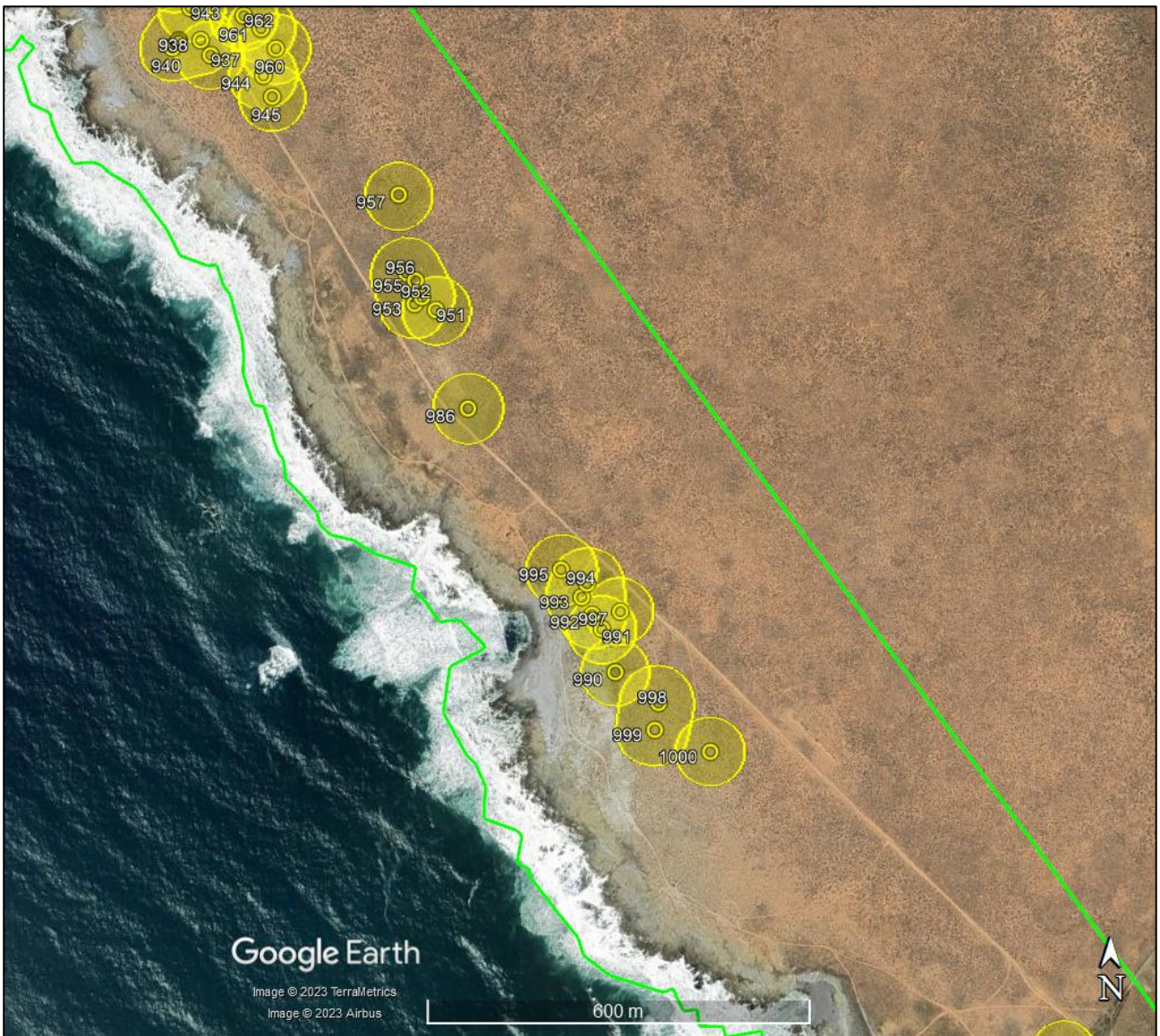

Figure 29: Enlargement from Figure 27.

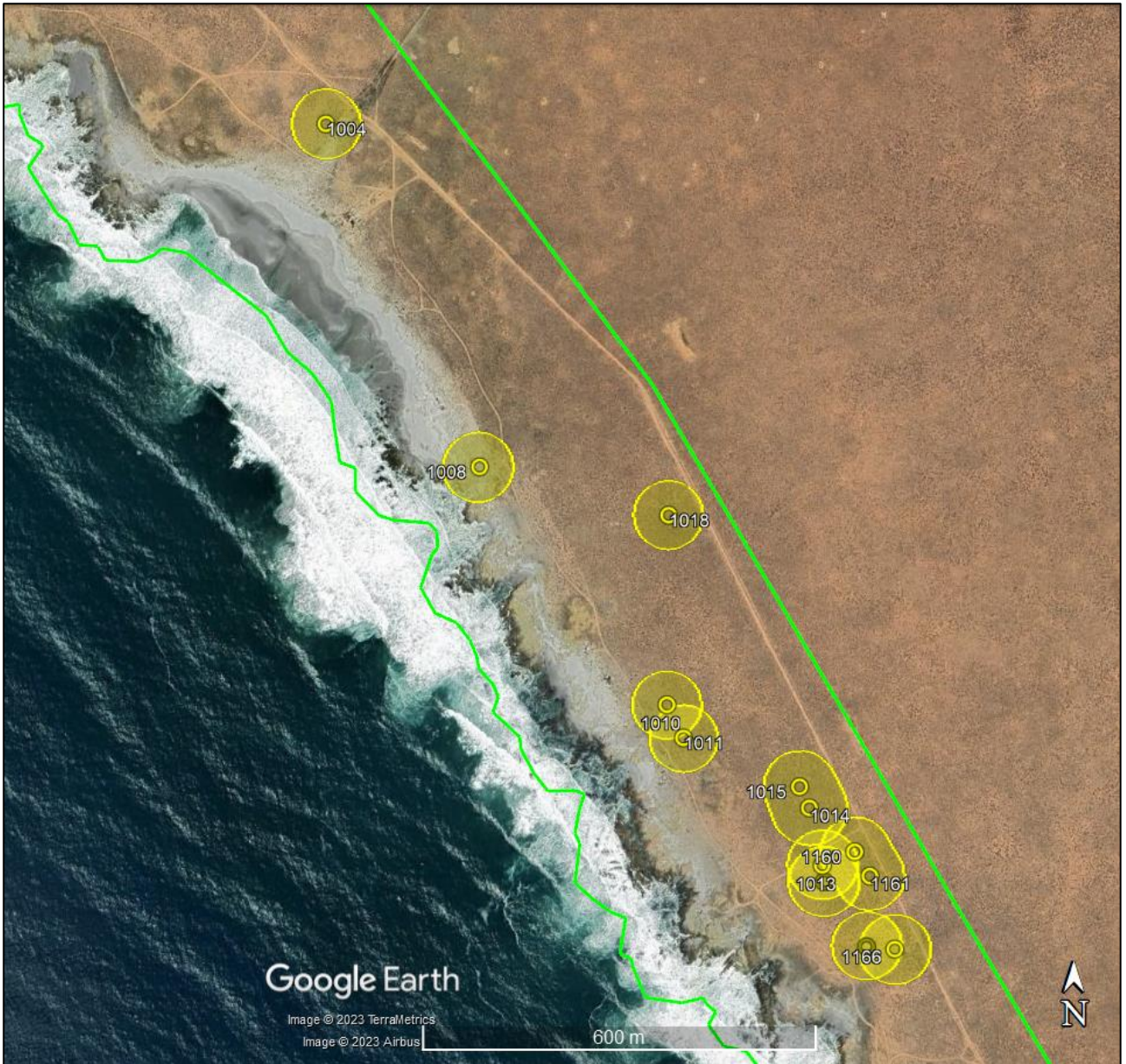

Figure 30: Enlargement from Figure 27.

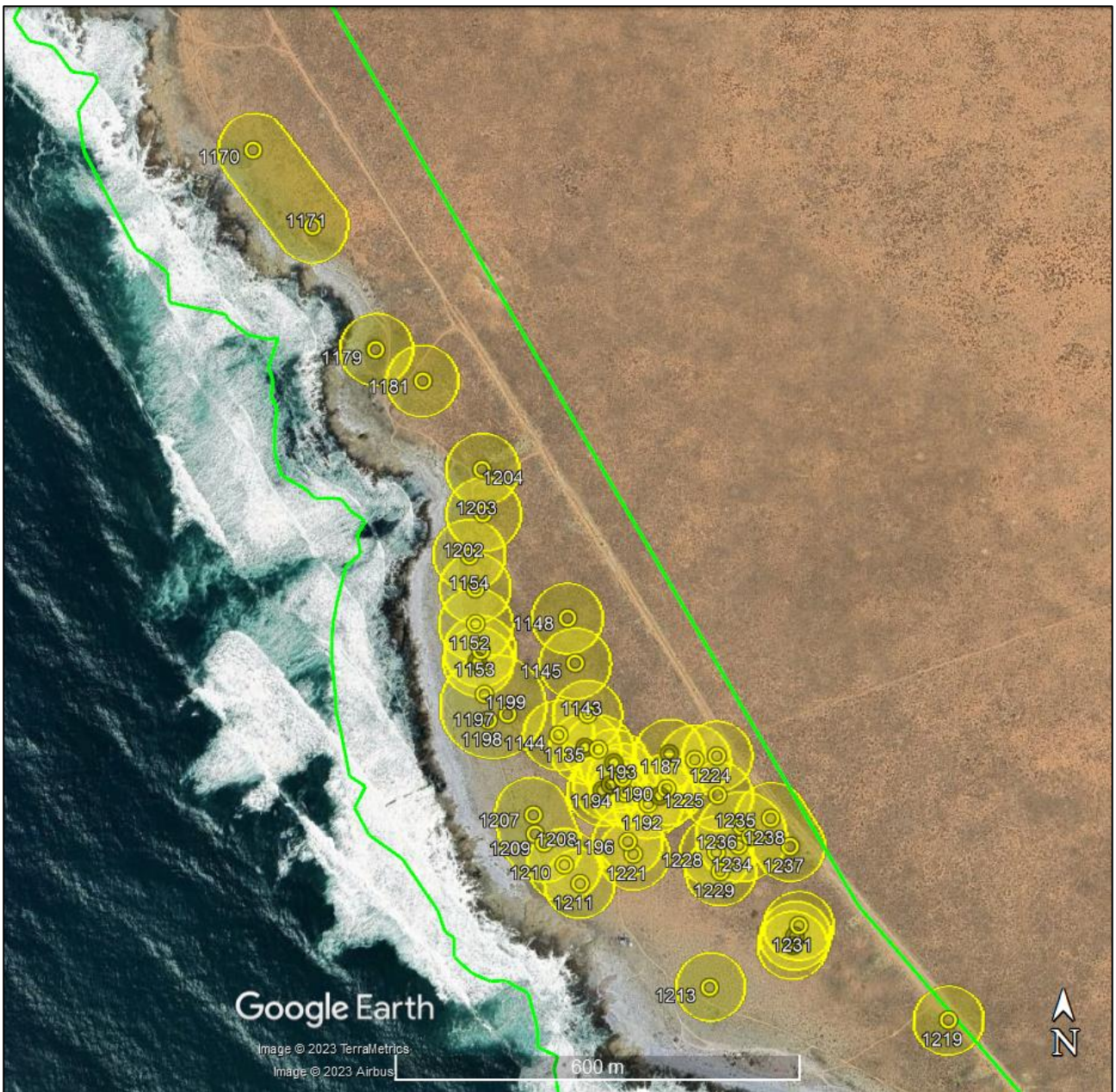

Figure 31: Enlargement from Figure 27.

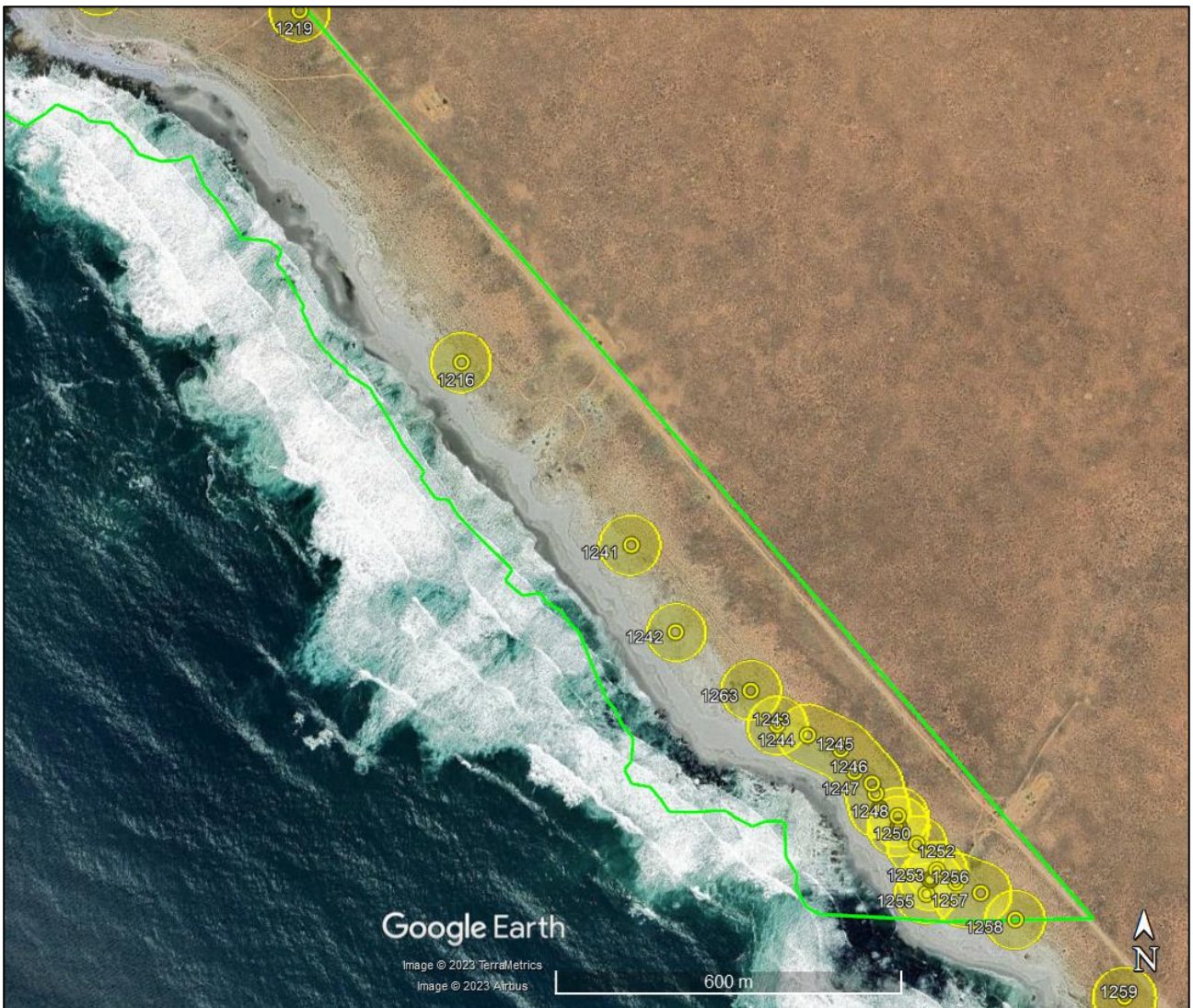

Figure 32: Enlargement from Figure 27.

5.8. Summary of heritage indicators

- Significant fossils should not be damaged or disturbed.
- Significant terrestrial archaeological sites should not be damaged or disturbed.
- Significant maritime archaeological sites should not be damaged or disturbed.
- Graves should not be damaged or disturbed.
- The landscape should not be dominated by the proposed work.

6. ASSESSMENT OF IMPACTS

The impacts identified for this project are:

- Impacts to palaeontology
- Impacts to terrestrial archaeology
- Impacts to maritime archaeology
- Impacts to graves
- Impacts to the cultural landscape

While palaeontological heritage and maritime archaeology are assessed in the separate specialist studies (appended to this HIA), all the other impacts are considered here. All phases are assessed as one since impacts could occur during preparation for test pits and/or drilling (construction phase), during excavation and/or drilling (operation phase) and during rehabilitation (decommissioning phase).

6.1. Impacts to archaeological resources

Direct impacts to archaeological resources could occur (1) when the mechanical excavator and/or drilling rig is driven to the site, (2) during prospecting when the surrounding surface gets disturbed, and (3) during rehabilitation when topsoil is spread around the area. It is noted that most impacts will occur on the beach where archaeological sites are lacking. However, promising finds may be followed inland where archaeology could then be intersected. Because the cultural significance of the identified sites is low on surface observations but could reach medium below surface, the impact intensity is anticipated to be up to medium and the overall significance before mitigation is rated as **medium negative** (Table 3). Mitigation will entail avoiding sensitive areas or, if not avoidable, commissioning archaeological mitigation work (excavations and sampling). Known sensitive areas have been mapped in this report but, because of their great frequency, the workers on site will need to be aware of any scatters of shell on the surface and should avoid those as far as possible. Existing roads should be used to access the beaches and none of the roads in the area should be widened; the cutting through the north bank of the Sout River is most important in this regard. Driving over a site once is not likely to cause significant impact but avoiding such sites is still best practice. With mitigation the significance is expected to be **low negative**.

There are no fatal flaws in terms of impacts to archaeology.

Table 3: Assessment of archaeological impacts (all phases).

Potential impacts on archaeological resources	
Nature and status of impact:	Direct, negative
Extent and duration of impact:	Local, permanent
Intensity	Medium
Probability of occurrence:	Probable
Degree to which the impact can be reversed:	Low
Degree to which the impact may cause irreplaceable loss of resources:	High
Cumulative impact prior to mitigation:	Low
Significance rating of impact prior to mitigation (Low, Medium, Medium-High, High, or Very-High)	Medium

Degree to which the impact can be mitigated:	High
Proposed mitigation:	<ul style="list-style-type: none"> • Avoid identified sensitive areas. • Make use of existing tracks as far as possible. • No widening of existing roads. • Be alert for shell scatters and avoid while on site.
Cumulative impact post mitigation:	Low
Significance rating of impact after mitigation (Low, Medium, Medium-High, High, or Very-High)	Low

6.2. Impacts to graves

Direct impacts to graves could occur (1) when the mechanical excavator and/or drilling rig is driven to the site, (2) during prospecting when the surrounding surface gets disturbed, and (3) during rehabilitation when topsoil is spread around the area. Because the cultural significance of graves is high, the impact intensity is anticipated to be high if graves are disturbed. The overall significance before mitigation is rated as **low negative**, however, because of the very low probability of graves being intersected during the work on site (Table 4). Mitigation will entail protecting and reporting any graves discovered accidentally during prospecting. Such graves would then need to be exhumed by an archaeologist. With mitigation the significance is expected to remain **low negative**.

There are no fatal flaws in terms of impacts to graves.

Table 4: Assessment of impacts to graves (all phases).

Potential impacts on archaeological resources	
Nature and status of impact:	Direct, negative
Extent and duration of impact:	Local, permanent
Intensity	High
Probability of occurrence:	Improbable
Degree to which the impact can be reversed:	Low
Degree to which the impact may cause irreplaceable loss of resources:	High
Cumulative impact prior to mitigation:	Low
Significance rating of impact prior to mitigation (Low, Medium, Medium-High, High, or Very-High)	Low
Degree to which the impact can be mitigated:	High
Proposed mitigation:	<ul style="list-style-type: none"> • Protect and report any chance finds of graves.
Cumulative impact post mitigation:	Low
Significance rating of impact after mitigation (Low, Medium, Medium-High, High, or Very-High)	Low

6.3. Impacts to the cultural landscape

Direct impacts to the cultural landscape would occur through the presence of the excavator/drilling rig and all prospecting-related activity in the landscape. The impacts will be of very low intensity but would definitely occur if the project goes ahead. Because the landscape has already been scarred by mining this is not a significant concern and the impact before mitigation is rated as **low negative** (Table 5). Mitigation will involve minimising the duration of all activities on site and ensuring

effective rehabilitation of all disturbed areas. The significance, however, will not change and remains **low negative**.

There are no fatal flaws in terms of construction phase impacts to the cultural landscape.

Table 5: Assessment of impacts to the cultural landscape (all phases).

Potential impacts on the cultural landscape	
Nature and status of impact:	Direct, negative
Extent and duration of impact:	Local, short term
Intensity	Low
Probability of occurrence:	Definite
Degree to which the impact can be reversed:	High
Degree to which the impact may cause irreplaceable loss of resources:	Low
Cumulative impact prior to mitigation:	Low
Significance rating of impact prior to mitigation (Low, Medium, Medium-High, High, or Very-High)	Low
Degree to which the impact can be mitigated:	Medium
Proposed mitigation:	<ul style="list-style-type: none"> • Minimise duration of drilling. • Ensure effective rehabilitation of all areas.
Cumulative impact post mitigation:	Low
Significance rating of impact after mitigation (Low, Medium, Medium-High, High, or Very-High)	Low

6.4. Cumulative impacts

Cumulative impacts to archaeology are not expected to be of concern since very little impact is likely to happen during the course of this project and archaeological resources are very widespread. Many other archaeological sites have been disturbed by the adjacent mining operation to the south, but in recent years mitigation excavations have been carried out, thereby rescuing some of the significant archaeological data and remains present on the landscape. Maritime archaeological remains are expected to be extremely rare with the result that impacts of any sort will be minimal. Impacts to fossils are unlikely and, in any case, would be minimal due to the small size of the disturbance. Cumulative impacts to the landscape are likely to be minimal since the presence of an excavator or drilling rig is very minor compared to the impact of the existing mining operation to the south of the study area and the proposed prospecting will be a temporary activity.

6.5. Evaluation of impacts relative to sustainable social and economic benefits

Section 38(3)(d) of the NHRA requires an evaluation of the impacts on heritage resources relative to the sustainable social and economic benefits to be derived from the development.

The project is seeking new mineral deposits. While the project itself will not have much socio-economic benefit, should a feasible resource be discovered and mining proceeds then considerable socio-economic benefits could accrue for the surrounding communities through jobs. If mitigation is applied as suggested above, then the socio-economic benefits outweigh the residual impacts.

6.6. Existing impacts to heritage resources

The main threat to heritage resources on the site is the illegal use of off-road vehicles which damage archaeological sites. Aside from this, natural weathering and erosion will also affect exposed archaeological materials. These impacts would be of **low negative** significance. There are no current impacts to fossils. The cultural landscape has been significantly altered by the existing mining operation to the south of the Karoetjieskop study area but, as one moves further north, that mine recedes into the distance and the landscape integrity increases with scarring from off-road vehicles and modification of the coastal strip and littering being the main concerns. Existing cultural landscape impacts in the wider area are rated as **medium negative** but on site they can be seen as generally **low negative** but with **medium negative** impacts in places along the shoreline.

6.7. The No-Go alternative

If the project were not implemented then the site would stay as it currently is (impact significance of **low negative**). Although the heritage impacts with implementation could be greater than the existing impacts, the loss of socio-economic benefits is more significant and suggests that the No-Go option is less desirable in heritage terms.

6.8. Levels of acceptable change

Any impact to an archaeological or palaeontological resource or a grave is deemed unacceptable until such time as the resource has been inspected and studied further if necessary. Impacts to the landscape are difficult to quantify but in general a development that visually dominates the landscape from many publicly accessible vantage points is undesirable. Because of the nature of the proposed development, such an impact to the landscape is not envisaged.

7. INPUT TO THE ENVIRONMENTAL MANAGEMENT PROGRAMME

The actions recorded in Table 6 should be included in the environmental management programme (EMPr) for the project.

Table 6: Heritage considerations for inclusion in the EMPr.

Impact	Mitigation / management objectives & outcomes	Mitigation / management actions	Monitoring		
			Methodology	Frequency	Responsibility
Impacts to palaeontology					
Damage or destruction of fossils	Locate and rescue fossils during prospecting	Inform project staff to be aware of the possibility of finding fossil bones and how to rescue them using the Chance Finds Procedure	Implementation of Chance Finds Procedure	Ongoing basis as required	Project Manager or Contractor
Impacts to archaeology and graves					
Damage or destruction of	Avoid impacts (preferred) or locate and sample or	Avoid known sensitive areas	Plot sensitive areas on project maps/plans	Once-off	Project developer

archaeological sites or graves	rescue sites/burials before disturbance	Be aware of surface shell scatters and avoid them during work	Inform staff to be vigilant	Ongoing basis	Project Manager or Contractor
		Reporting chance finds as early as possible, protect <i>in situ</i> and stop work in immediate area.	Inform staff to be vigilant	Ongoing basis	Project Manager or Contractor
Damage or destruction of archaeological sites or graves	Avoid impacts (preferred) or locate and sample or rescue sites	Plan onshore work well in advance and appoint archaeologist to conduct mitigation work if required.	Ensure that archaeological work is conducted and HWC approval is received.	Once-off	Project developer
Impacts to the cultural landscape					
Visible landscape scarring	Minimise landscape scarring	Ensure disturbance is kept to a minimum and does not exceed project requirements.	Monitoring of surface clearance relative to approved layout	Ongoing basis	Project Manager or Contractor
		Rehabilitate all areas on completion.	Monitoring of rehabilitation process	Once-off	Project Manager or Contractor

8. CONSULTATION WITH HERITAGE CONSERVATION BODIES

This report will be sent to the local municipality for heritage comment as required by HWC. The results will be submitted to HWC on completion.

9. CONCLUSIONS

The main concern for this project is archaeology. Significant palaeontological impacts are unlikely due to the scarcity of fossils and impacts to maritime archaeological resources are highly unlikely. However, a large number of terrestrial archaeological sites were found within the study area. These have been mapped in this report and the relevant areas must be avoided during the prospecting work on site or else subjected to archaeological mitigation as needed. Landscape impacts have also been found to be of no concern. Table 7 lists the heritage indicators and project responses.

Table 7: Heritage indicators and project responses.

Indicator	Project Response
Significant fossils should not be damaged or disturbed.	Significant impacts are not expected.
Significant terrestrial archaeological sites should not be damaged or disturbed.	Significant sites should be easily avoided by the prospecting (recommendations are made in this regard) but project staff will need to be vigilant during moving of the excavator and drilling rig.
Significant maritime archaeological sites should not be damaged or disturbed.	Significant impacts are not expected.

Graves should not be damaged or disturbed.	Impacts to graves are extremely unlikely and, in any case, they cannot be predicted.
The landscape should not be dominated by the proposed work.	The drilling rig will constitute only a very small visual intrusion and is of no further concern.

Although the impacts from driving over an archaeological site are unlikely to be of much significance, every effort should be made on site to avoid this happening. This will mean having all sites plotted onto project maps and only making use of existing tracks.

9.1. Reasoned opinion of the specialist

Given that it should be easy to avoid the identified sensitive areas on site, it is the opinion of the heritage specialist that the proposed prospecting on Portion 1 and the Remainder of Karoetjies Kop 151 may be authorised in full.

10. RECOMMENDATIONS

It is recommended that the proposed prospecting be authorised, but subject to the following recommendations which should be included as conditions of authorisation:

- A Fossil Chance Finds Procedure must be incorporated in the EMPr for the project and project staff must be made aware of the possibility of finding fossil bones during prospecting;
- The identified sensitive areas (including the buffer zones) must be avoided as far as possible by all project activities;
- If avoidance is not possible then an archaeologist must be consulted with regards to the need for mitigation. It may be feasible to work within some of the buffers but if archaeological material will be at risk then mitigation excavations must be carried out in advance of prospecting;
- Project staff must be made aware of the possibility of finding further Stone Age sites in between those recorded and, should any shell scatters be seen, these must be avoided;
- Project staff must be made aware of the possibility of finding buried wreckage debris or even graves related to shipwrecks;
- No road widening may take place;
- Existing tracks should be used for access as far as possible;
- All prospecting sites must be rehabilitated; and
- If any archaeological terrestrial or maritime material, fossils or human burials are uncovered during the course of development then work in the immediate area should be halted. The find would need to be reported to the heritage authorities and may require inspection by an archaeologist or palaeontologist. Such heritage is the property of the state and may require excavation and curation in an approved institution.

11. REFERENCES

- Dewar, G. 2008. *The archaeology of the coastal desert of Namaqualand, South Africa: a regional synthesis*. Oxford: British Archaeological Reports International Series 1761.
- Dewar, G., Halkett, D., Hart, T., Orton, J. and Sealy, J. 2006. Implications of a mass kill site of springbok (*Antidorcas marsupialis*) in South Africa: hunting practices, gender relations and sharing in the Later Stone Age. *Journal of Archaeological Science* 33: 1266-1275.
- Dewar, G. & Stewart, B.A. 2012. Preliminary results of excavations at Spitzkloof Rockshelter, Richtersveld, South Africa. *Quaternary International* 270: 30-39.
- Dewar, G. & Stewart, B. 2017. Early Maritime Desert Dwellers in Namaqualand, South Africa: A Holocene Perspective on Pleistocene Peopling. *Journal of Island and Coastal Archaeology* 12: 44-64.
- Ellis, F. & Schloms, B.H.A. 1980. Observations on the properties and genesis of dorbank soils in the Western Cape Province. Technical Communication, Department of Agricultural Technical Services, Republic of South Africa 165: 178-181.
- Halkett, D. 2000a. An assessment of the impacts on heritage resources of proposed mining on the farm Karoetjies Kop, Vredendal District. Unpublished report prepared for Metago Environmental Engineers (Pty) Ltd. Archaeology Contracts Office, University of Cape Town.
- Halkett, D. 2000b. An initial assessment of heritage resources within the Transhex west coast diamond concessions. Unpublished report prepared for Trans Hex Mining Ltd. Archaeology Contracts Office, University of Cape Town.
- Halkett, D. 2001. An inspection and assessment of a Middle Stone Age site at the Groen River mouth: Namaqualand. Unpublished report prepared for De Beers Consolidated Mines NM. Archaeology Contracts Office, University of Cape Town.
- Halkett, D. 2002a. An analysis of a randomly collected Early Stone Age artefact assemblage from the Sandkop Mining Area, Kleinsee, Namaqualand. Unpublished report prepared for De Beers Consolidated Mines NM. Archaeology Contracts Office, University of Cape Town.
- Halkett, D. 2002b. Phase 1 archaeological survey: assessment of mining blocks in the BMC and KN areas, Namaqualand. Unpublished report prepared for De Beers Consolidated Mines NM. Archaeology Contracts Office, University of Cape Town.
- Halkett, D. 2006. Phase 1 archaeological assessment of mining targets in the BMC and KNC mining areas, Namaqualand, April/May 2006. Unpublished report prepared for De Beers Consolidated Mines NM. Archaeology Contracts Office, University of Cape Town.
- Halkett, D. 2019. Archaeological Impact Assessment: proposed prospecting in the coastal setback zone at Namakwa Sands, Matzikama Municipality, Western Cape. Report prepared for SRK Consulting (South Africa) (Pty) Ltd. St James: ACO Associates cc.
- Halkett, D.J., Hart, T.J.G. & Parkington, J. 1993. Excavations at six archaeological sites in the near shore diamond mining area, Brandsebaai, Namaqualand. Unpublished report prepared for De Beers Namaqualand Mines Division. Archaeology Contracts Office, University of Cape Town.
- Halkett, D.J. & Hart, T.J.G. 1994. Report on Phase 2 archaeological excavations at the Namakwa Sands Project (first phase) Vredendal District. Unpublished report prepared for Namakwa Sands Ltd. Archaeology Contracts Office, University of Cape Town.
- Halkett, D.J. & Hart, T.J.G. 1997. An archaeological assessment of the coastal strip, and a proposed heritage management plan for: De Beers Namaqualand Mines. Unpublished report prepared for De Beers Consolidated Mines NM. Archaeology Contracts Office, University of Cape Town.

- Halkett, D., Hart, T.J.G. & Parkington J.E. 1993. Excavations at six archaeological sites in the near shore diamond mining area, Brand se Baai, Namaqualand. Unpublished report prepared for De Beers Namaqualand Mines Division. University of Cape Town: Archaeology Contracts Office.
- Halkett, D. & Orton, J. 2007. Phase 1 archaeological assessment of mining block extensions in the KNC mining area, Namaqualand, May 2007. Unpublished report prepared for De Beers Consolidated Mines NM. Archaeology Contracts Office, University of Cape Town.
- Halkett, D., Hart, T., Yates, R., Volman, T.P., Parkington, J., Orton, J., Klein, R.G., Cruz-Uribe, K. & Avery, G. 2003. First excavation of intact Middle Stone Age layers at Ysterfontein, Western Cape Province, South Africa: implications for Middle Stone Age ecology. *Journal of Archaeological Science* 30: 955-971.
- Harris, J. & Smith, I. 2005. The Te Hoe Shore Whaling Station Artefact Assemblage. Otago Archaeological Laboratory Report: Number 2. Otago Archaeological Laboratory, Anthropology Department, University of Otago.
- Hart, T. 1994. Phase 1 archaeological assessment of contractor's truck stop, Namakwa Sands Project. Unpublished report prepared for Namakwa Sands Ltd. Archaeology Contracts Office, University of Cape Town.
- Hart, T. 1999. A phase 1 archaeological assessment of the proposed Liebenbergs Bay Mine, Vredendal. Unpublished report prepared for Rency (Pty) Ltd. Archaeology Contracts Office, University of Cape Town.
- Hart, T. 2003. Phase 1 archaeological assessment of proposed diamond mining areas situated at the farms Geelwal Karoo, Klipvley Karoo Kop and Graauduinen, Vredendal District, Western Cape. Unpublished report prepared for SRK Consulting. University of Cape Town, Archaeology Contracts Office.
- Hart, T. 2006. Namakwa Sands EMPR Amendment specialist study report on heritage. Unpublished report prepared for Golder Associates. University of Cape Town, Archaeology Contracts Office.
- Hart, T. 2007. Heritage Impact Assessment (prepared as part of an EIA) of a proposed Wind Energy Facility to be situated at Olifants River Settlement 617, 620 and Grave Water Kop 158/5 situated on the Namaqualand Coast in the Vredendal District, South Western Cape. Unpublished report prepared for Savannah Environmental (Pty) Ltd. University of Cape Town, Archaeology Contracts Office.
- Hart, T. & Halkett, D. 1994. Report on Phase 2 archaeological excavations at the Namakwa Sands Project (First Phase) Vredendal District Namaqualand. Unpublished report prepared for Namakwa Sands Ltd. University of Cape Town, Archaeology Contracts Office.
- Hart, T. & Halkett, D. 1999. A phase one archaeological assessment of the proposed Liebenbergs Bay Mine, Vredendal. Unpublished report prepared for Rency (Pty) Ltd. University of Cape Town, Archaeology Contracts Office.
- Hart, T. & Lanham, J. 1997. Phase 2 archaeological excavations at two Late Stone Age sites in the Phase II (WOB) mining area, Namakwa Sands, Vredendal District, Western Cape. Unpublished report prepared for Namakwa Sands Ltd. University of Cape Town: Archaeology Contracts Office
- Heritage Western Cape. 2016. Grading: purpose and management implications. Document produced by Heritage Western Cape, 16 March 2016.
- Heritage Western Cape. 2019. Public consultation guidelines. Document produced by Heritage Western Cape, June 2019.

- Heritage Western Cape. 2021. Guide for Minimum Standards for Archaeology and Palaeontology reports submitted to Heritage Western Cape. Document produced by Heritage Western Cape, February 2021.
- Heritage Western Cape. 2021. Notification of Intent to Develop, Heritage Impact Assessment, (Pre-Application) Basic Assessment Reports, Scoping Reports and Environmental Impact Assessments, Guidelines for submission to Heritage Western Cape. Document produced by Heritage Western Cape, February 2021.
- Law, M. & Dalglish, C. 2015. Namakwa Sands: Expansion into Satellite Deposits Environmental Impact Assessment Report and Environmental Management Programme Report. Unpublished report prepared for Tronox Mineral Sands (Pty) Ltd. Rondebosch: SRK Consulting (South Africa) (Pty) Ltd.
- Lavin, J. & Wiltshire, N. 2018. Archaeological Report Addendum In terms of Section 38(8) of the NHRA for a Brand se Baai (West mine), Namaqualand. Report prepared for SRK. Plumstead: CTS Heritage.
- Mackay, A., Orton, J., Schwartz, S. & Steele, T. 2010. Soutfontein (SFT)-001: preliminary report on an open-air site rich in bifacial points, southern Namaqualand, South Africa. *South African Archaeological Bulletin* 65: 84-95.
- Manhire, A. 1987a. *Later Stone Age Settlement Patterns in the Sandveld of the South-Western Cape Province, South Africa*. Oxford: British Archaeological Reports International Series 351.
- Manhire, A. 1987b. Sandveld deflation hollows: a study of open site assemblages in the south-western Cape. In: Parkington, J. & Hall, M. (eds) *Papers in the prehistory of the western Cape, South Africa*: 326-3449. British Archaeological Reports International Series 332(ii).
- Morris, A. 1992. *A master catalogue: Holocene human skeletons from South Africa*. Johannesburg: Witwatersrand University Press.
- Morris, D. 2004. Archaeological resources inland from Kleinzee: a Phase 1 archaeological impact assessment. Unpublished report prepared for De Beers Consolidated Mines NM. McGregor Museum, Kimberley.
- Morris, D. & Webley, L. 2004. Cultural history in and adjacent to the Namaqua National Park. Unpublished report prepared for SAN Parks. Kimberley & Grahamstown, McGregor and Albany Museums.
- Orton, J. 2007a. Mitigation of archaeological sites within the Buffels Marine, Buffels Inland and Koingnaas Complexes, Namaqualand, August to September 2007. Unpublished report prepared for De Beers Consolidated Mines NM. Archaeology Contracts Office, University of Cape Town.
- Orton, J. 2007b. Phase 1 archaeological assessment of mining targets in the BIC and KNC mining areas, Namaqualand, August 2007. Unpublished report prepared for De Beers Consolidated Mines NM. Archaeology Contracts Office, University of Cape Town.
- Orton, J. 2007c. The sampling of ephemeral shell scatters in Namaqualand, South Africa. *South African Archaeological Bulletin* 62: 74-78.
- Orton, J. 2010a. Heritage impact assessment for the proposed above ground temporary water supply pipeline near Koekenaap, Vredendal Magisterial District, Western Cape. Unpublished report prepared for Savannah Environmental. Archaeology Contracts Office, University of Cape Town.
- Orton, J. 2010b. Heritage impact assessment for the proposed Exxaro West Coast Wind Energy Facility on the southern Namaqualand coast, Vredendal Magisterial District, Western Cape. Unpublished report prepared for Savannah Environmental. St James: ACO Associates cc.

- Orton, J. 2010c. Heritage Impact Assessment for the services upgrade in Alexander Bay, Namakwa Magisterial District, Northern Cape. Unpublished report prepared for Doug Jeffery Environmental Consultants (Pty) Ltd. Archaeology Contracts Office, University of Cape Town.
- Orton, J. 2011a. Heritage assessment of prospecting borehole locations near Klaver, Vanrhynsdorp Magisterial District, Western Cape. Unpublished report prepared for SitePlan. University of Cape Town, Archaeology Contracts Office.
- Orton, J. 2011b. Heritage impact assessment for the proposed Vredendal Inca Solar Energy Facility, Vredendal Magisterial District, Western Cape. Unpublished report prepared for Savannah Environmental (Pty) Ltd. Diep River: ACO Associates cc.
- Orton, J. 2012. Late Holocene archaeology in Namaqualand, South Africa: hunter-gatherers and herders in a semi-arid environment. Unpublished D.Phil. Dissertation. Oxford: University of Oxford.
- Orton, J. 2012b. Tortoise burials in Namaqualand: uncovering ritual behaviour on South Africa's west coast. *Azania: archaeological research in Africa* 47: 99-114.
- Orton, J. 2013. Geometric rock art in western South Africa and its implications for the spread of early herding. *South African Archaeological Bulletin* 68: 27-40.
- Orton, J. 2014. The late pre-colonial site of Komkans 2 (KK002) and an evaluation of the evidence for indigenous copper smelting in Namaqualand, southern Africa. *Azania: Archaeological Research in Africa* 49: 386-410.
- Orton, J. 2015a. Archaeological mitigation at Namakwa Sands, Brand-se-Baai, Vredendal Magisterial District, Western Cape: Langlaagte 3 & Soutpan 2. Unpublished report prepared for Tronox Mineral Sands (Pty) Ltd. Muizenberg: ASHA Consulting (Pty) Ltd.
- Orton, J. 2015b. Archaeological mitigation at Namakwa Sands, Brand-se-Baai, Vredendal Magisterial District, Western Cape: Langlaagte 3 Extension. Unpublished report prepared for Tronox Mineral Sands (Pty) Ltd. Muizenberg: ASHA Consulting (Pty) Ltd.
- Orton, J. 2015c. Archaeological mitigation at Namakwa Sands, Brand-se-Baai, Vredendal Magisterial District, Western Cape: Soutpan 1. Unpublished report prepared for Tronox Mineral Sands (Pty) Ltd. Muizenberg: ASHA Consulting (Pty) Ltd.
- Orton, J. 2015d. Radiocarbon dates from Hartebeeskom 156, Namakwa Sands. Unpublished letter to Tronox Mineral Sands (Pty) Ltd. Muizenberg: ASHA Consulting (Pty) Ltd.
- Orton, J. 2016. Prehistoric cultural landscapes in South Africa: a typology and discussion. *South African Archaeological Bulletin* 71: 119-129.
- Orton, J. 2017a. Archaeological survey of new mining blocks at the Namakwa Sands Mine, Brand-se-Baai, Vredendal Magisterial District, Western Cape. Unpublished report prepared for Tronox Mineral Sands (Pty) Ltd. Lakeside: ASHA Consulting (Pty) Ltd.
- Orton, J. 2017b. Archaeological mitigation at the Tronox Namakwa Sands Mine, Vredendal Magisterial District, Western Cape. Unpublished report prepared for Tronox Mineral Sands (Pty) Ltd. Lakeside: ASHA Consulting (Pty) Ltd.
- Orton, J. 2017c. Heritage Impact Assessment for new mining and prospecting areas at the Namakwasands Mine, Brand-se-Baai, Vredendal Magisterial District, Western Cape. Unpublished report prepared for Tronox Mineral Sands (Pty) Ltd. Lakeside: ASHA Consulting (Pty) Ltd.
- Orton, J. 2018. VR048: An open-air Later Stone Age site on the Knersvlakte of southern Namaqualand. *South African Archaeological Bulletin* 73: 126-137.
- Orton, J. 2023. Heritage Impact Assessment: proposed prospecting on Karoetjies Kop 150/RE, Vredendal Magisterial District, Western Cape. Report prepared for TPR Mining Resources (Pty) Ltd. Lakeside: ASHA Consulting (Pty) Ltd.

- Orton, J. & Halkett, D. 2004. Phase 1 archaeological survey: assessment of mining blocks and prospecting trenches in the BMC and KNC areas, Namaqualand. Unpublished report prepared for De Beers Consolidated Mines NM. Archaeology Contracts Office, University of Cape Town.
- Orton, J. & Halkett, D. 2006. Mitigation of archaeological sites within the Buffels Marine and Koingnaas Complexes, Namaqualand, September 2005 to May 2006. Unpublished report prepared for De Beers Consolidated Mines, NM. University of Cape Town, Archaeology Contracts Office.
- Orton, J., Klein, R.G., Mackay, A. Schwartz, S. & Steele, T.E. 2011. Two Holocene rock shelter deposits from the Knersvlakte, southern Namaqualand, South Africa. *Southern African Humanities* 23: 109-150.
- Orton, J. & Webley, L. 2009. Phase 1 archaeological impact assessment of mining areas in the Oena Mine, Richtersveld, Namakwaland Magisterial District, Northern Cape. Unpublished report prepared for Surf Zone Diamonds (Pty) Ltd. ACO Associates, St James.
- Orton, J. & Webley, L. 2012a. Heritage impact assessment for the proposed ESKOM Kleinsee Wind Energy Facility, Namakwaland Magisterial District, Northern Cape. Unpublished report prepared for Savannah Environmental (Pty) Ltd. Diep River: ACO Associates cc.
- Orton, J. & Webley, L. 2012b. Heritage impact assessment for the proposed Project Blue Wind Energy Facility, Kleinsee, Namakwa Magisterial District, Northern Cape. Unpublished report prepared for Savannah Environmental (Pty) Ltd. Diep River: ACO Associates cc.
- Patrick, M. & Manhire, A. 2014. Proposed Tronox Namakwa Sands Mine Expansion, Western Cape Province: archaeological desktop study, scoping site survey & impact assessment. Unpublished report prepared for SRK Consulting (Pty) Ltd. Rondebosch: Cape Archaeological Survey cc.
- Parkington, J. & Hart, T. 1993. Namakwa Sands Main Access Road archaeological survey. Unpublished report prepared for the Environmental Evaluation Unit, University of Cape Town. Archaeology Contracts Office, University of Cape Town.
- Parkington, J.E. & Poggenpoel, C. 1990. West coast heavy mineral sands project: archaeological report. Unpublished report prepared for the Environmental Evaluation Unit, University of Cape Town. Archaeology Contracts Office, University of Cape Town.
- Pether, J. 2023. Palaeontological Impact Assessment (Desktop Study) Proposed Richwill Diamonds Prospecting on the farm Karoetjies Kop 150 part of Portion 1/150 & seaward part of RE/150 Namaqualand, Matzikama Local Municipality, West Coast District Vredendal Magisterial District, Western Cape WC10430PRKommetjie: John Pether.
- Rudner, J. & Rudner, I. 1968. Rock-art in the thirstland areas. *South African Archaeological Bulletin* 23: 75-89
- Sauer, C.O. 1925. The Morphology of Landscape. University of California Publications on Geography 2(2): 19-54.
- Steele, T.E., Mackay, A., Orton, J. & Schwartz, S. 2012. Varsche Rivier 003, a new Middle Stone age site in southern Namaqualand, South Africa. *South African Archaeological Bulletin* 67: 108-119.
- Steele, T.E., Mackay, A., Fitzsimmons, K., Igreja, M., Marwick, B., Orton, J., Schwartz, S. & Stahlschmidt, M. 2016. Varsche Rivier 003: a Middle and Later Stone Age site with Still Bay and Howiesons Poort assemblages in southern Namaqualand, South Africa. *PaleoAnthropology* 2016: 100-163.
- Van der Ryst, M., Küsel, S. & Coetzee, F. Heritage Impact Assessment for the proposed expansion at Grouwduin Se Kop and Hartebeeste Kom as part of the Tronox Namakwa Sands Mine, Brand-Se-Baai, Vredendal Magisterial District, West Coast District Municipality. Report prepared

for Environmental Assurance (Pty) Ltd. Habitat Landscape Architects Pty (Ltd) & Francois P Coetzee Heritage Consultant.

Webley, L. 1984. Archaeology and ethnoarchaeology in the Leliefontein Reserve and surrounds, Namaqualand. Unpublished MA Dissertation, University of Stellenbosch.

Winter, S. & Baumann, N. 2005. Guideline for involving heritage specialists in EIA processes: Edition 1. CSIR Report No ENV-S-C 2005 053 E. Republic of South Africa, Provincial Government of the Western Cape, Department of Environmental Affairs & Development Planning, Cape Town.

Winter, S. & Oberholzer, B. 2013. Heritage and Scenic Resources: Inventory and Policy Framework for the Western Cape. Report prepared for the Provincial Government of the Western Cape Department of Environmental Affairs and Development Planning. Sarah Winter Heritage Planner, and Bernard Oberholzer Landscape Architect / Environmental Planner, in association with Setplan.

APPENDIX 1 – Curriculum Vitae



Curriculum Vitae

Jayson David John Orton

ARCHAEOLOGIST AND HERITAGE CONSULTANT

Contact Details and personal information:

Address: 23 Dover Road, Muizenberg, 7945
Telephone: (021) 788 1025
Cell Phone: 083 272 3225
Email: jayson@asha-consulting.co.za

Birth date and place: 22 June 1976, Cape Town, South Africa
Citizenship: South African
ID no: 760622 522 4085
Driver's License: Code 08
Marital Status: Married to Carol Orton
Languages spoken: English and Afrikaans

Education:

SA College High School	Matric	1994
University of Cape Town	B.A. (Archaeology, Environmental & Geographical Science) 1997	
University of Cape Town	B.A. (Honours) (Archaeology)*	1998
University of Cape Town	M.A. (Archaeology)	2004
University of Oxford	D.Phil. (Archaeology)	2013

*Frank Schweitzer memorial book prize for an outstanding student and the degree in the First Class.

Employment History:

Spatial Archaeology Research Unit, UCT	Research assistant	Jan 1996 – Dec 1998
Department of Archaeology, UCT	Field archaeologist	Jan 1998 – Dec 1998
UCT Archaeology Contracts Office	Field archaeologist	Jan 1999 – May 2004
UCT Archaeology Contracts Office	Heritage & archaeological consultant	Jun 2004 – May 2012
School of Archaeology, University of Oxford	Undergraduate Tutor	Oct 2008 – Dec 2008
ACO Associates cc	Associate, Heritage & archaeological consultant	Jan 2011 – Dec 2013
ASHA Consulting (Pty) Ltd	Director, Heritage & archaeological consultant	Jan 2014 –

Professional Accreditation:

Association of Southern African Professional Archaeologists (ASAPA) membership number: 233

CRM Section member with the following accreditation:

- Principal Investigator: Coastal shell middens (awarded 2007)
Stone Age archaeology (awarded 2007)
Grave relocation (awarded 2014)
- Field Director: Rock art (awarded 2007)
Colonial period archaeology (awarded 2007)

Association of Professional Heritage Practitioners (APHP) membership number: 43

- Accredited Professional Heritage Practitioner

➤ **Memberships and affiliations:**

South African Archaeological Society Council member	2004 – 2016
Assoc. Southern African Professional Archaeologists (ASAPA) member	2006 –
UCT Department of Archaeology Research Associate	2013 – 2017
Heritage Western Cape APM Committee member	2013 –
UNISA Department of Archaeology and Anthropology Research Fellow	2014 –
Fish Hoek Valley Historical Association	2014 –
Kalk Bay Historical Association	2016 –
Association of Professional Heritage Practitioners member	2016 –

Fieldwork and project experience:

Extensive fieldwork and experience as both Field Director and Principle Investigator throughout the Western and Northern Cape, and also in the western parts of the Free State and Eastern Cape as follows:

Feasibility studies:

- Heritage feasibility studies examining all aspects of heritage from the desktop

Phase 1 surveys and impact assessments:

- Project types
 - Notification of Intent to Develop applications (for Heritage Western Cape)
 - Desktop-based Letter of Exemption (for the South African Heritage Resources Agency)
 - Heritage Impact Assessments (largely in the Environmental Impact Assessment or Basic Assessment context under NEMA and Section 38(8) of the NHRA, but also self-standing assessments under Section 38(1) of the NHRA)
 - Archaeological specialist studies
 - Phase 1 archaeological test excavations in historical and prehistoric sites
 - Archaeological research projects
- Development types
 - Mining and borrow pits
 - Roads (new and upgrades)
 - Residential, commercial and industrial development
 - Dams and pipe lines
 - Power lines and substations
 - Renewable energy facilities (wind energy, solar energy and hydro-electric facilities)

Phase 2 mitigation and research excavations:

- ESA open sites
 - Duinefontein, Gouda, Namaqualand
- MSA rock shelters
 - Fish Hoek, Yzerfontein, Cederberg, Namaqualand
- MSA open sites
 - Swartland, Bushmanland, Namaqualand
- LSA rock shelters
 - Cederberg, Namaqualand, Bushmanland
- LSA open sites (inland)
 - Swartland, Franschoek, Namaqualand, Bushmanland
- LSA coastal shell middens
 - Melkbosstrand, Yzerfontein, Saldanha Bay, Paternoster, Dwarskersbos, Infanta, Knysna, Namaqualand
- LSA burials
 - Melkbosstrand, Saldanha Bay, Namaqualand, Knysna
- Historical sites
 - Franschoek (farmstead and well), Waterfront (fort, dump and well), Noordhoek (cottage), variety of small excavations in central Cape Town and surrounding suburbs
- Historic burial grounds
 - Green Point (Prestwich Street), V&A Waterfront (Marina Residential), Paarl

Awards:

Western Cape Government Cultural Affairs Awards 2015/2016: Best Heritage Project.

APPENDIX 2 – Mapping

In the maps that follow:

- The proposed prospecting right area is outlined in green;
- Grade IIIC sites are numbered yellow circles with 50 m buffers; and
- Grade NCW sites are numbered white circles without buffers.

The mapping proceeds from northwest to southeast along the length of the study area.

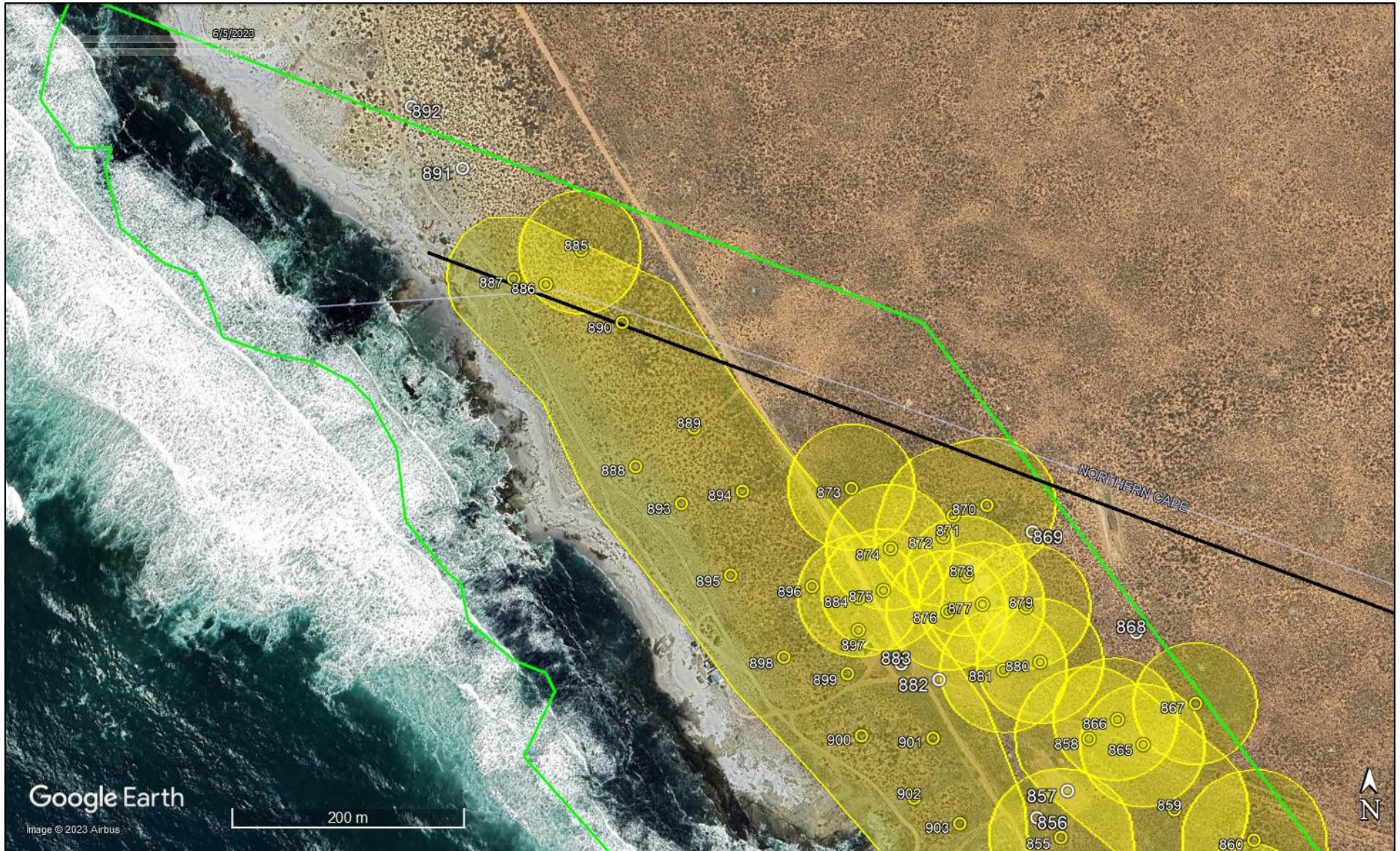

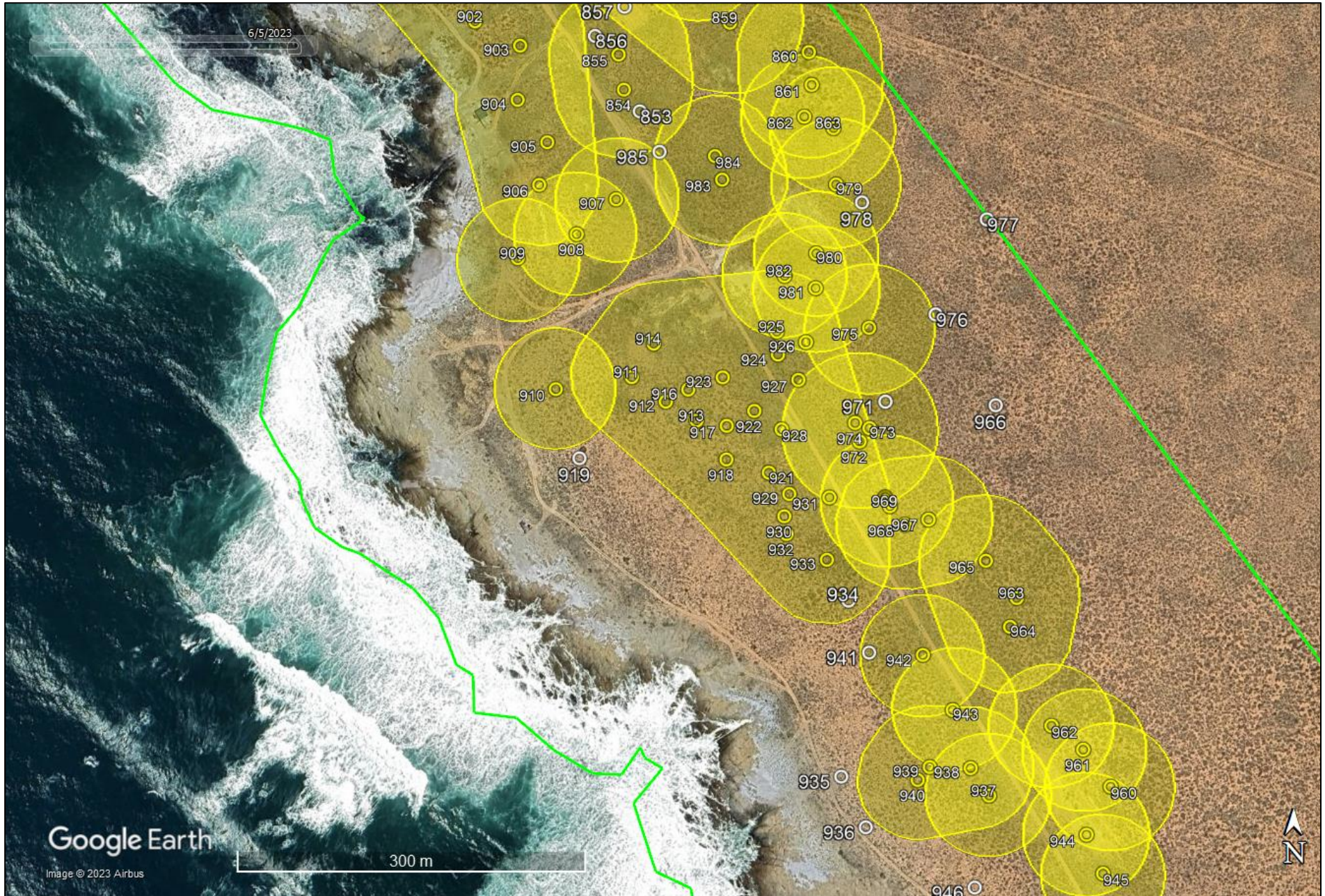

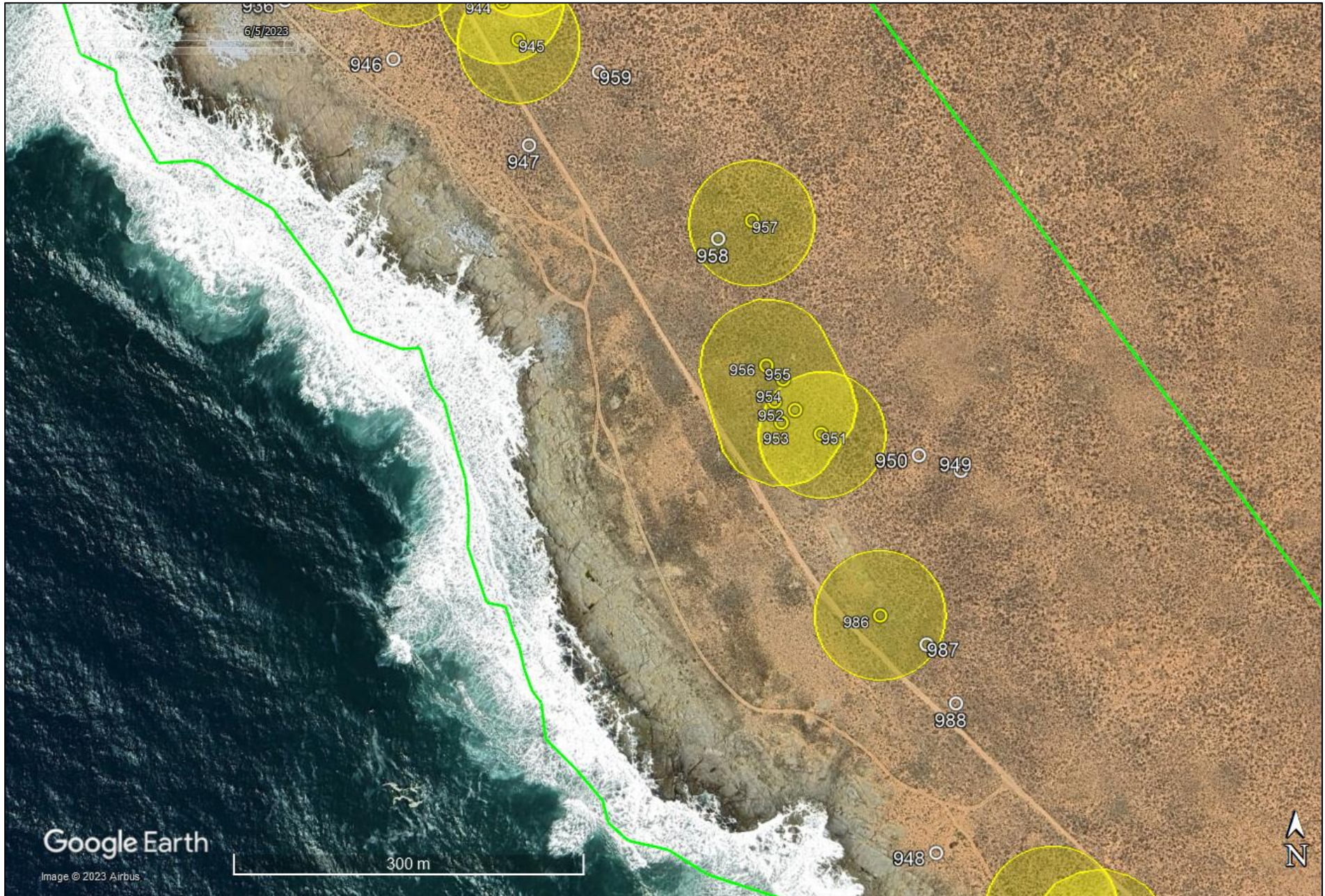

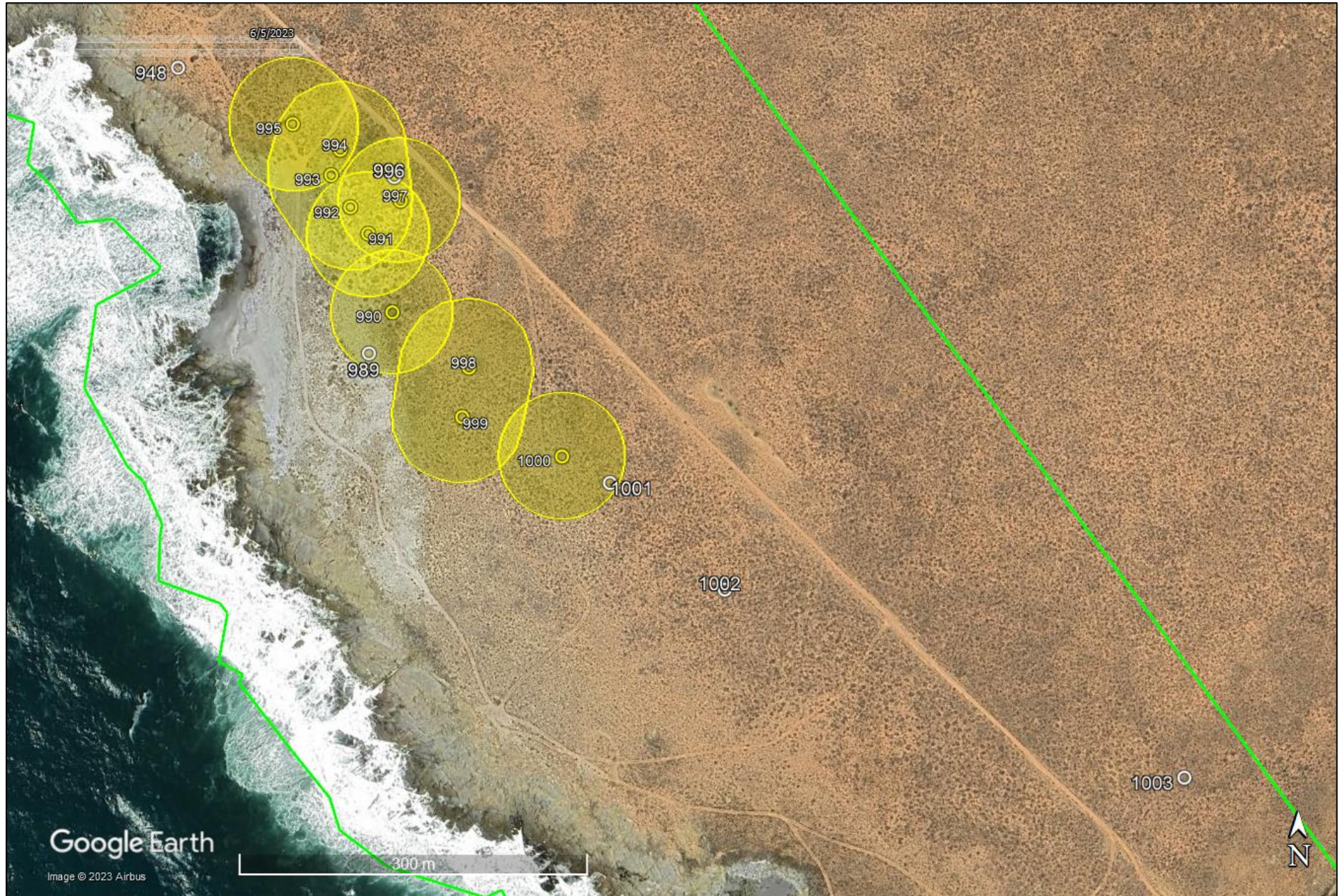

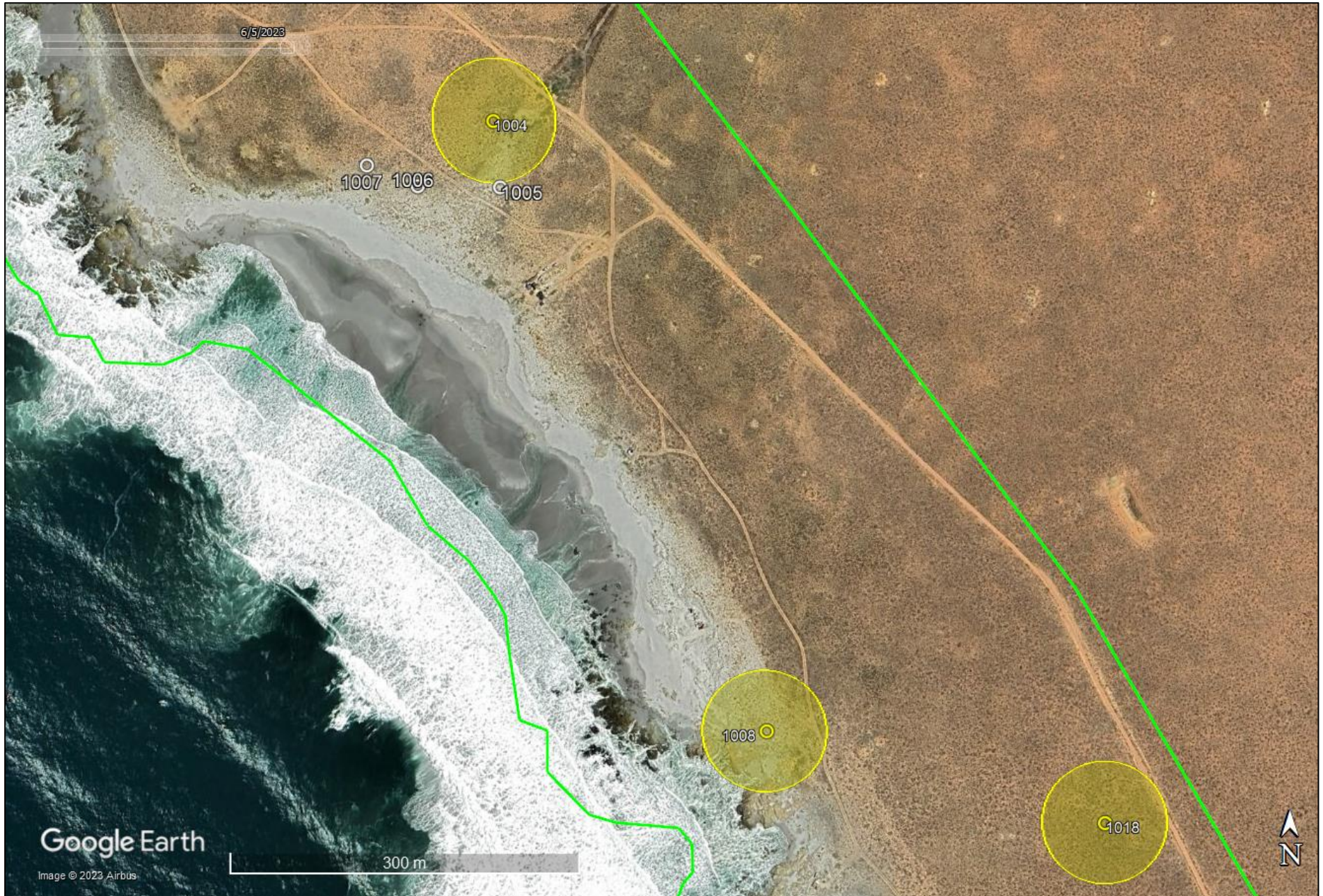

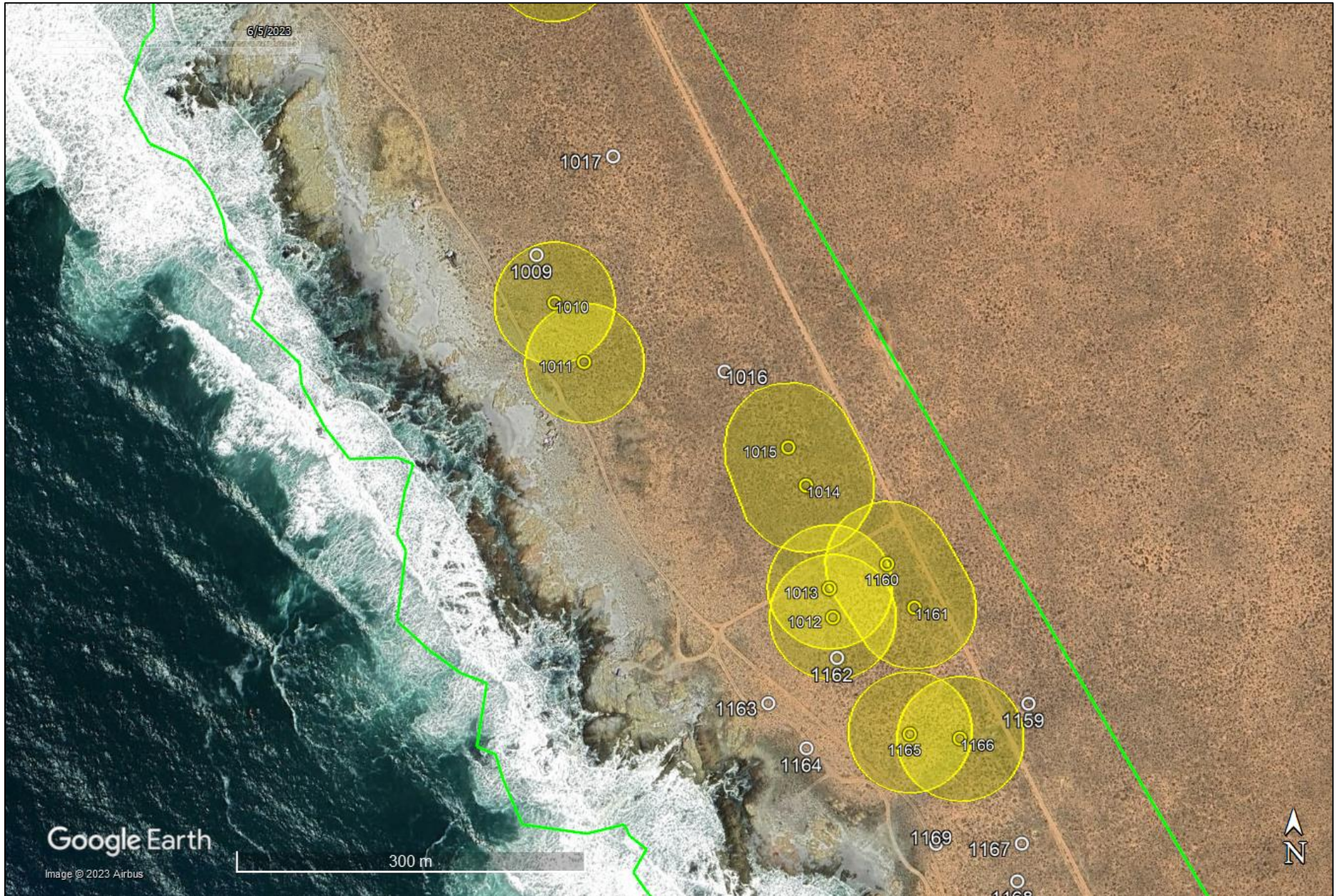

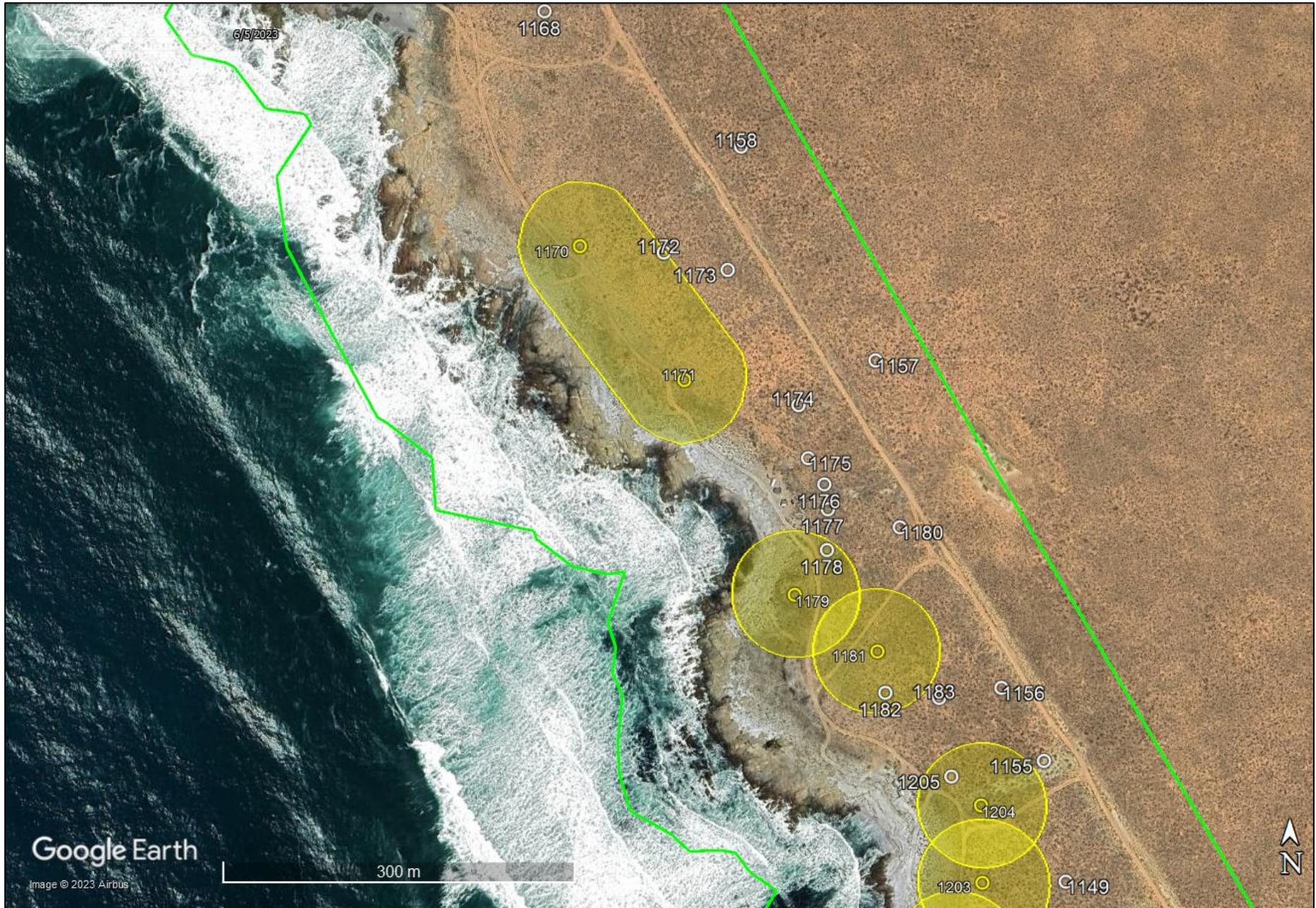

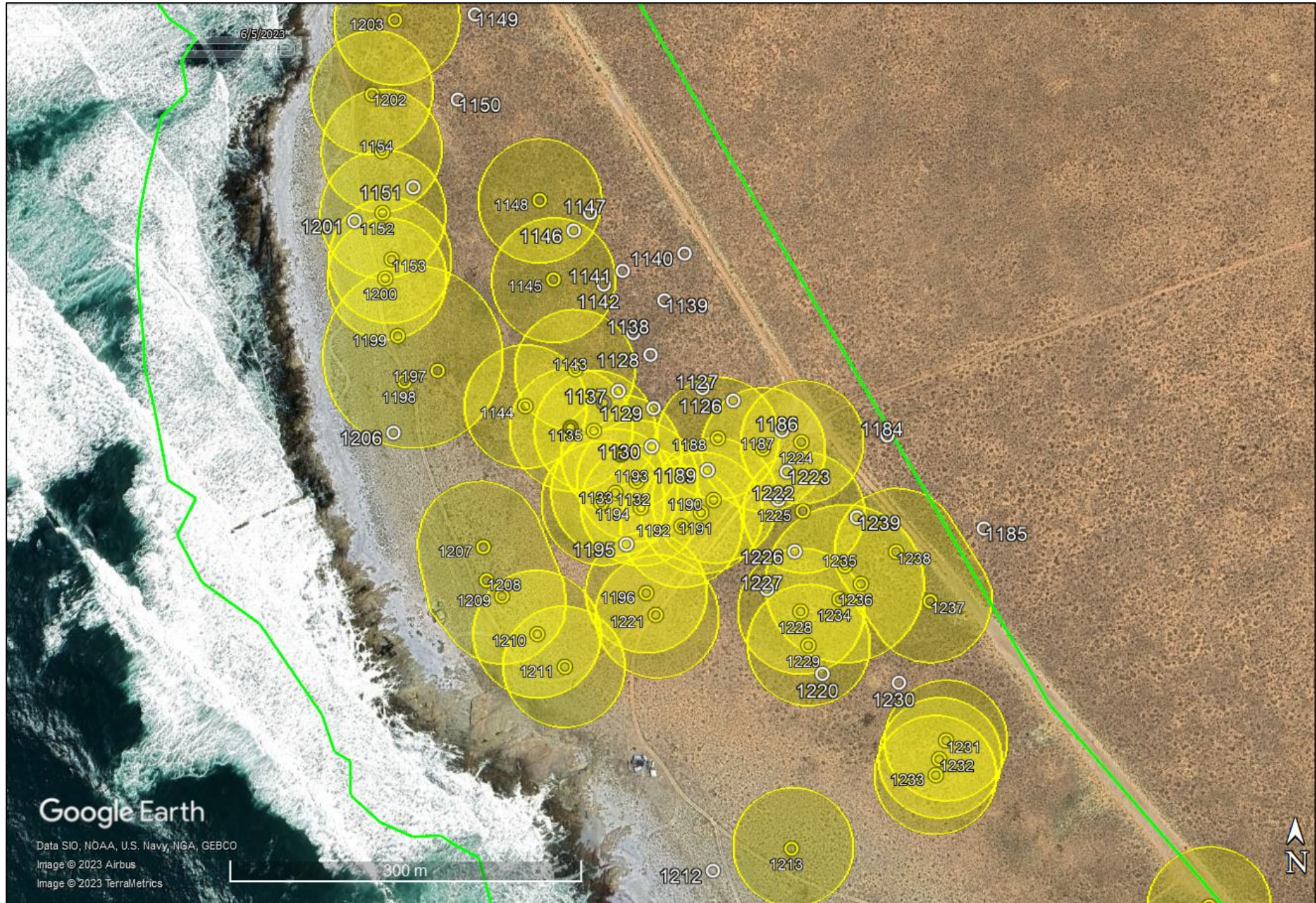



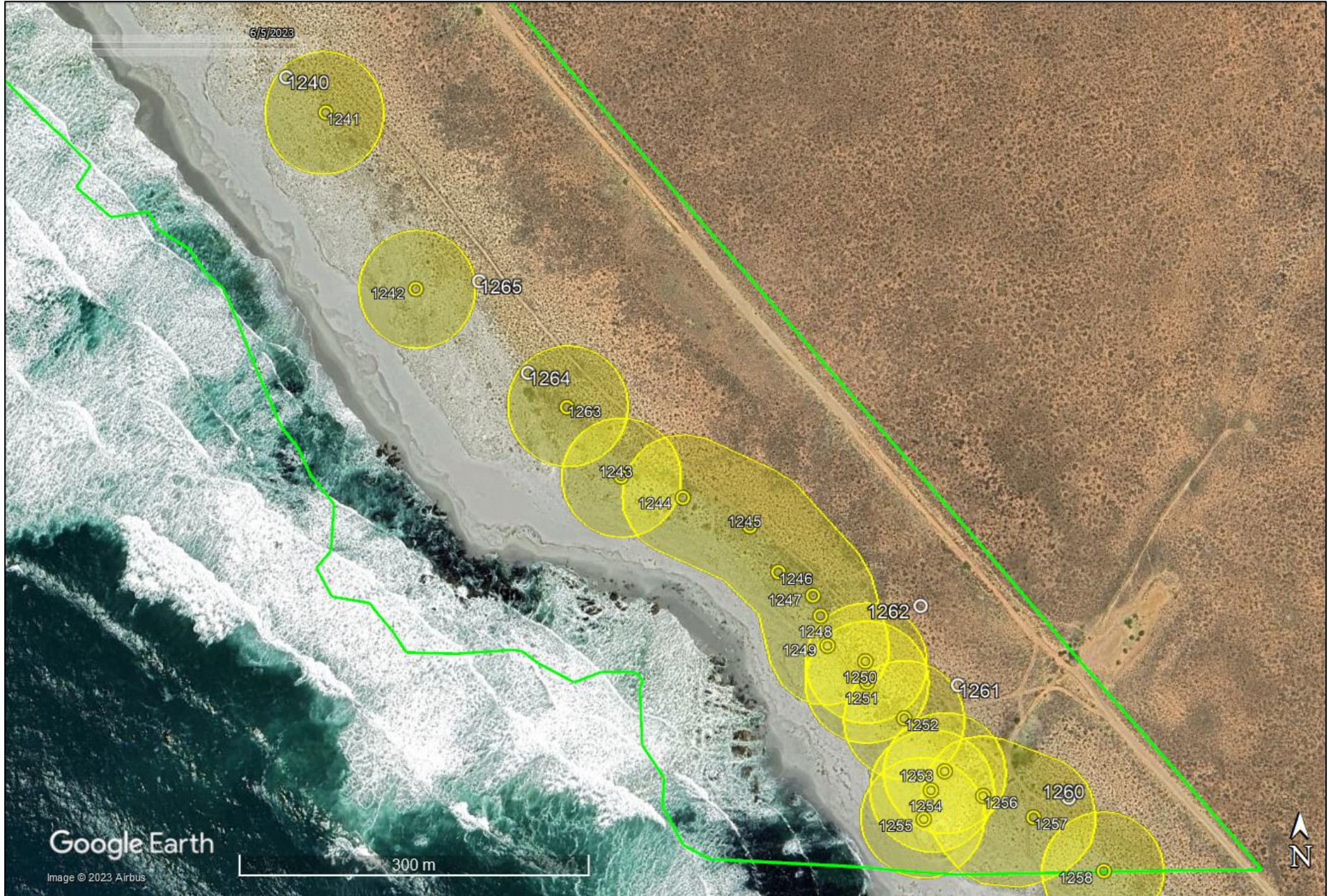

APPENDIX 3 – Palaeontological specialist study

APPENDIX 4 – Maritime archaeological specialist study