**DESKTOP HERITAGE SURVEY OF THE PROPOSED
MAMATWAN MANGANESE MINE**

FOR JEFFARES & GREEN

DATE: 8 APRIL 2016

By Gavin Anderson

**Umlando: Archaeological Surveys and Heritage
Management**

PO Box 102532, Meerensee, 3901

Phone/fax: 035-7531785 Fax: 0865445631

Cell: 0836585362



TABLE OF CONTENT

INTRODUCTION	3
NATIONAL HERITAGE RESOURCES ACT OF 1999	7
METHOD	9
DESKTOP STUDY	13
PALAEONTOLOGICAL IMPACT ASSESSMENT	18
CONCLUSION	18
REFERENCES	19
APPENDIX A	20
DECLARATION OF SPECIALIST	20
APPENDIX B	22
PALAEONTOLOGICAL DESKTOP REPORT	22

TABLE OF FIGURES

FIG. 1 GENERAL LOCATION OF THE MAMATWAN MANGANESE MINE	4
FIG. 2: AERIAL OVERVIEW OF THE MAMATWAN MANGANESE MINE	5
FIG. 3: TOPOGRAPHICAL MAP OF THE MAMATWAN MANGANESE MINE	6
TABLE 1: SAHRA GRADINGS FOR HERITAGE SITES	12
FIG. 4: KNOWN HERITAGE SITES IN THE AREA	14
FIG. 5: SURVEYOR GENEREAL MAP OF 1896	15
FIG. 6: 1898 MAP OF KING 561	16
FIG. 7: LOCALITY MAP IN 1974	17

INTRODUCTION

The Mamatwan Manganese Mine is situated approximately 21km south of the town of Hotazel. Mining areas include the Remaining Extent of Portion 3, Portion 8, Portion 18 and the Remaining Extent of the Farm Mamatwan No. 331 RD. The mining area falls within the municipal boundaries of the John Taolo Gaetsewe District and Joe Morelong Local Municipality.

Due to the Mamatwan Mine being located within the water scarce Northern Cape Province, South32 has embarked on a process with the design engineers, Knight Piesold, to design and establish a Slimes Handling and Bulk Water Storage Facility with the objective of optimizing the management of clean and low quality water. It is understood that the facility will make provision for the Slimes Facility that will allow for waste water from site facilities such as stormwater channels, oil separators and run-off from slimes facilities to be contained and recycled back into the water use of the processing plant. Similarly, the Bulk Water Storage Facility is to receive treated water pumped from the pit, as well as any excess water from the operations for further use on the mine.

The Mamatwan Mine is operating under an approved Environmental Management Programme Report (EMPr), now known as an Environmental Authorisation (EA) and an Integrated Water Use License (IWUL) to mine manganese by opencast mining methods. However, the mine's proposed handling of the slimes and bulk water storage will trigger requirements in terms of the National Environmental Management Act (Act 107 of 1998) (NEMA), the National Environmental Management: Waste Amendment Act (Act 26 of 2014) (NEM: WA) and the National Water Act (Act 36 of 1998) (NWA)."

As per a Pre-Application Meeting held with the Northern Cape Department of Minerals, a desktop Heritage Impact Assessment is to be undertaken for the proposed development, to be included as a Specialist Study in the EIA Process.

Figures 1 -3 show the location of the study area.

FIG. 1 GENERAL LOCATION OF THE MAMATWAN MANGANESE MINE

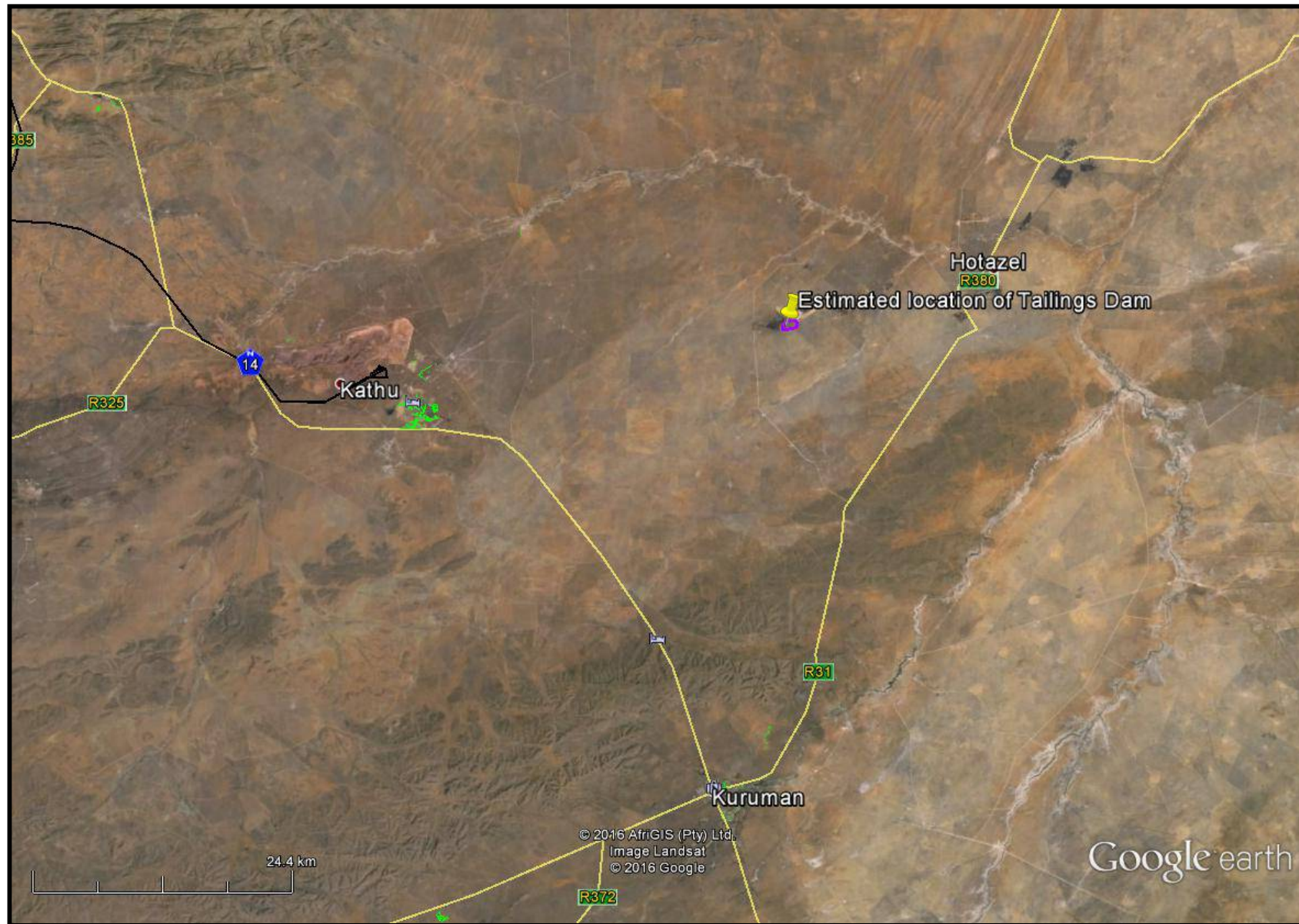

FIG. 2: AERIAL OVERVIEW OF THE MAMATWAN MANGANESE MINE

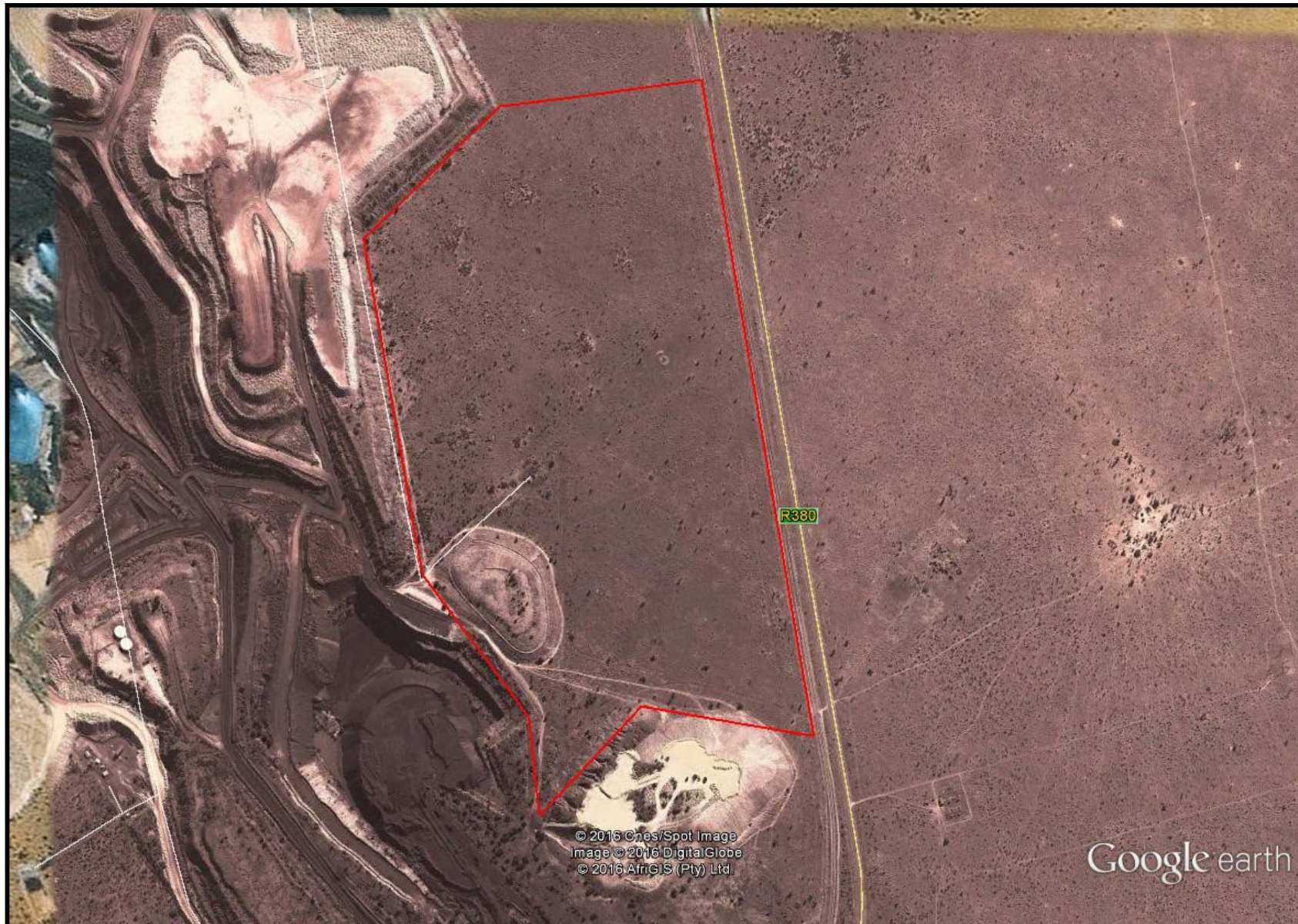
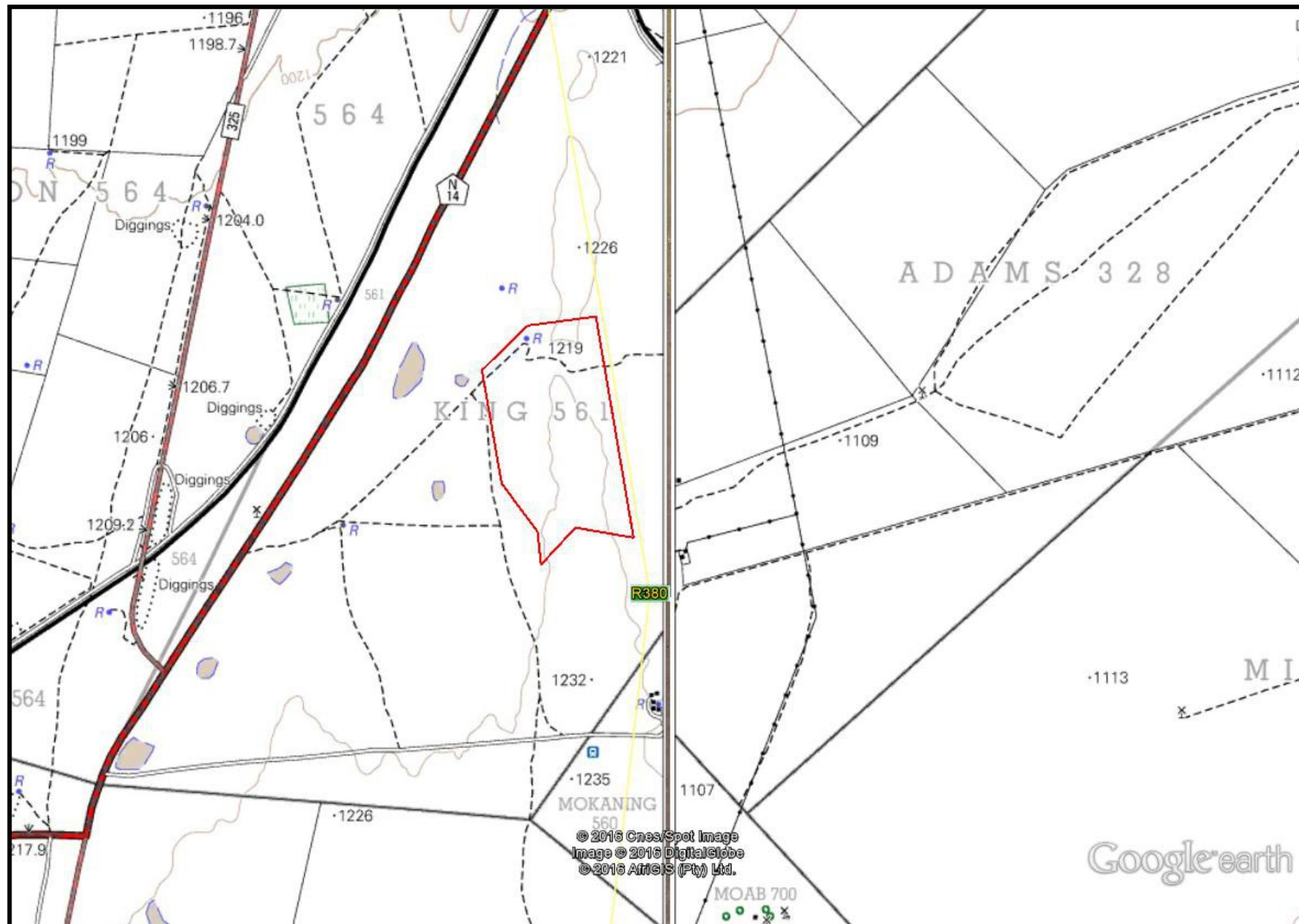

FIG. 3: TOPOGRAPHICAL MAP OF THE MAMATWAN MANGANESE MINE



NATIONAL HERITAGE RESOURCES ACT OF 1999

The National Heritage Resources Act of 1999 (pp 12-14) protects a variety of heritage resources. These resources are defined as follows:

1. “For the purposes of this Act, those heritage resources of South Africa which are of cultural significance or other special value for the present community and for future generations must be considered part of the national estate and fall within the sphere of operations of heritage resources authorities.
2. Without limiting the generality of subsection (1), the national estate may include—
 - 2.1. Places, buildings, structures and equipment of cultural significance;
 - 2.2. Places to which oral traditions are attached or which are associated with living heritage;
 - 2.3. Historical settlements and townscapes;
 - 2.4. Landscapes and natural features of cultural significance;
 - 2.5. Geological sites of scientific or cultural importance;
 - 2.6. Archaeological and palaeontological sites;
 - 2.7. Graves and burial grounds, including—
 - 2.7.1. Ancestral graves;
 - 2.7.2. Royal graves and graves of traditional leaders;
 - 2.7.3. Graves of victims of conflict;
 - 2.7.4. Graves of individuals designated by the Minister by notice in the Gazette;
 - 2.7.5. Historical graves and cemeteries; and
 - 2.7.6. Other human remains which are not covered in terms of the Human Tissue Act, 1983 (Act No. 65 of 1983);
3. Sites of significance relating to the history of slavery in South Africa;
 - 3.1. Movable objects, including—

4. Objects recovered from the soil or waters of South Africa, including archaeological and palaeontological objects and material, meteorites and rare geological specimens;
 - 4.1. Objects to which oral traditions are attached or which are associated with living heritage;
 - 4.2. Ethnographic art and objects;
 - 4.3. Military objects;
 - 4.4. objects of decorative or fine art;
 - 4.5. Objects of scientific or technological interest; and
 - 4.6. books, records, documents, photographic positives and negatives, graphic, film or video material or sound recordings, excluding those that are public records as defined in section 1(xiv) of the National Archives of South Africa Act, 1996 (Act No. 43 of 1996).
5. Without limiting the generality of subsections (1) and (2), a place or object is to be considered part of the national estate if it has cultural significance or other special value because of—
 - 5.1. Its importance in the community, or pattern of South Africa's history;
 - 5.2. Its possession of uncommon, rare or endangered aspects of South Africa's natural or cultural heritage;
 - 5.3. Its potential to yield information that will contribute to an understanding of South Africa's natural or cultural heritage;
 - 5.4. Its importance in demonstrating the principal characteristics of a particular class of South Africa's natural or cultural places or objects;
 - 5.5. Its importance in exhibiting particular aesthetic characteristics valued by a community or cultural group;
 - 5.6. Its importance in demonstrating a high degree of creative or technical achievement at a particular period;
 - 5.7. Its strong or special association with a particular community or cultural group for social, cultural or spiritual reasons;
 - 5.8. Its strong or special association with the life or work of a person, group or organisation of importance in the history of South Africa; and

5.9. sites of significance relating to the history of slavery in South Africa”

METHOD

The method for Heritage assessment consists of several steps.

The first step forms part of the desktop assessment. Here we would consult the database that has been collated by Umlando. These database contain archaeological site locations and basic information from several provinces (information from Umlando surveys and some colleagues), most of the national and provincial monuments and battlefields in Southern Africa (<http://www.vuvuzela.com/googleearth/monuments.html>) and cemeteries in southern Africa (information supplied by the Genealogical Society of Southern Africa). We use 1st and 2nd edition 1:50 000 topographical and 1937 aerial photographs where available, to assist in general location and dating of buildings and/or graves. The database is in Google Earth format and thus used as a quick reference when undertaking desktop studies. Where required we would consult with a local data recording centre, however these tend to be fragmented between different institutions and areas and thus difficult to access at times. We also consult with an historical architect, palaeontologist, and an historian where necessary.

The survey results will define the significance of each recorded site, as well as a management plan.

All sites are grouped according to low, medium, and high significance for the purpose of this report. Sites of low significance have no diagnostic artefacts or features. Sites of medium significance have diagnostic artefacts or features and these sites tend to be sampled. Sampling includes the collection of artefacts for future analysis. All diagnostic pottery, such as rims, lips, and decorated sherds are sampled, while bone, stone, and shell are mostly noted. Sampling usually

occurs on most sites. Sites of high significance are excavated and/or extensively sampled. Those sites that are extensively sampled have high research potential, yet poor preservation of features.

Defining significance

Heritage sites vary according to significance and several different criteria relate to each type of site. However, there are several criteria that allow for a general significance rating of archaeological sites.

These criteria are:

1. State of preservation of:

- 1.1. Organic remains:
 - 1.1.1. Faunal
 - 1.1.2. Botanical
- 1.2. Rock art
- 1.3. Walling
- 1.4. Presence of a cultural deposit
- 1.5. Features:
 - 1.5.1. Ash Features
 - 1.5.2. Graves
 - 1.5.3. Middens
 - 1.5.4. Cattle byres
 - 1.5.5. Bedding and ash complexes

2. Spatial arrangements:

- 2.1. Internal housing arrangements
- 2.2. Intra-site settlement patterns
- 2.3. Inter-site settlement patterns

3. Features of the site:

- 3.1. Are there any unusual, unique or rare artefacts or images at the site?

3.2. Is it a type site?

3.3. Does the site have a very good example of a specific time period, feature, or artefact?

4. Research:

4.1. Providing information on current research projects

4.2. Salvaging information for potential future research projects

5. Inter- and intra-site variability

5.1. Can this particular site yield information regarding intra-site variability, i.e. spatial relationships between various features and artefacts?

5.2. Can this particular site yield information about a community's social relationships within itself, or between other communities?

6. Archaeological Experience:

6.1. The personal experience and expertise of the CRM practitioner should not be ignored. Experience can indicate sites that have potentially significant aspects, but need to be tested prior to any conclusions.

7. Educational:

7.1. Does the site have the potential to be used as an educational instrument?

7.2. Does the site have the potential to become a tourist attraction?

7.3. The educational value of a site can only be fully determined after initial test-pit excavations and/or full excavations.

8. Other Heritage Significance:

8.1. Palaeontological sites

8.2. Historical buildings

8.3. Battlefields and general Anglo-Zulu and Anglo-Boer sites

8.4. Graves and/or community cemeteries

8.5. Living Heritage Sites

8.6. Cultural Landscapes, that includes old trees, hills, mountains, rivers, etc related to cultural or historical experiences.

The more a site can fulfill the above criteria, the more significant it becomes. Test-pit excavations are used to test the full potential of an archaeological deposit. This occurs in Phase 2. These test-pit excavations may require further excavations if the site is of significance (Phase 3). Sites may also be mapped and/or have artefacts sampled as a form of mitigation. Sampling normally occurs when the artefacts may be good examples of their type, but are not in a primary archaeological context. Mapping records the spatial relationship between features and artefacts.

TABLE 1: SAHRA GRADINGS FOR HERITAGE SITES

SITE SIGNIFICANCE	FIELD RATING	GRADE	RECOMMENDED MITIGATION
High Significance	National Significance	Grade 1	Site conservation / Site development
High Significance	Provincial Significance	Grade 2	Site conservation / Site development
High Significance	Local Significance	Grade 3A / 3B	
High Medium Significance	/ Generally Protected A		Site conservation or mitigation prior to development / destruction
Medium Significance	Generally Protected B		Site conservation or mitigation / test excavation / systematic sampling / monitoring prior to or during development / destruction
Low Significance	Generally Protected C		On-site sampling monitoring or no archaeological mitigation required prior to or during development / destruction

DESKTOP STUDY

The desktop study consisted of analysing various maps for evidence of prior habitation in the study area, as well as for previous archaeological surveys.

PREVIOUS ACHAEOLOGICAL & HERITAGE SURVEYS

There have been several HIA and AIA studies undertaken in the general area; however none occur in the study area (Archaetnos 2012; Matakoma Heritage Consultants. 2005; Pistorius. 2008; PGS Heritage 2009). Most of these surveys found no heritage sites, while one located isolated MSA tools and some recent historical structures. PGS Heritage (2009) gives a summary of the history of the area. Two of these surveys were on the adjacent farms.

No national monuments, battlefields, or historical cemeteries are known to occur in the study area. Historical cemeteries occur outside of the study area (fig. 4).

In summary, the various studies indicate that the neighbouring area has several interspersed Stone Age scatters and some historical buildings. The late Iron Age and Historical Period settlements tend to occur near riverbanks. There are also several transport roads running across the landscape and these may have associated temporary settlements.

The consensus is that there is low archaeological significance in this area.

FIG. 4: KNOWN HERITAGE SITES IN THE AREA

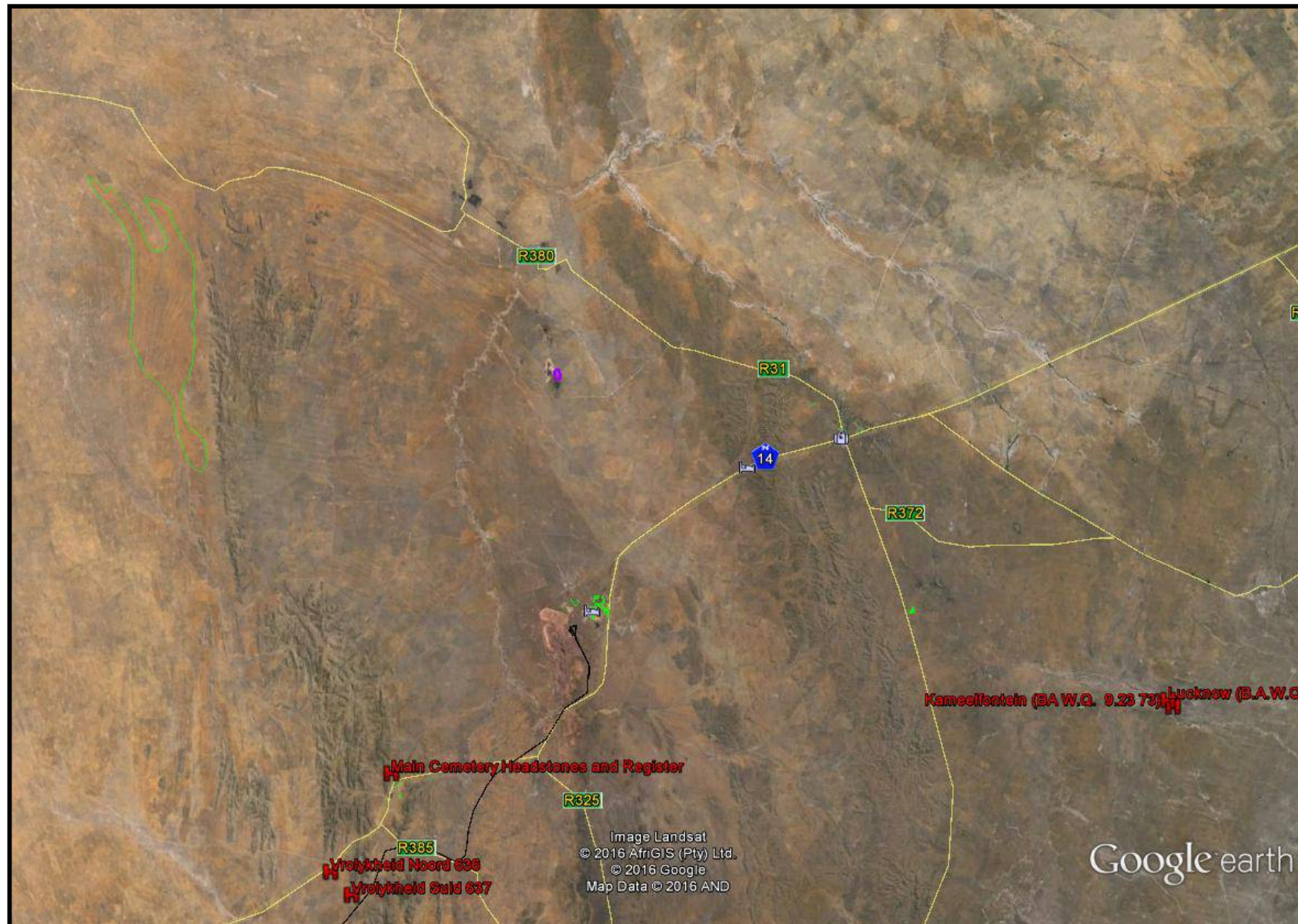

A brief search of the Surveyor General maps indicates that the study area formed part of the "Confiscated land" related to the Langeberg Rebellion (see PGS 2009). King .561 occurred in the southeastern part of this annexation (Fig.'s 5 – 6). No structures are shown on these maps.

FIG. 5: SURVEYOR GENERAL MAP OF 1896

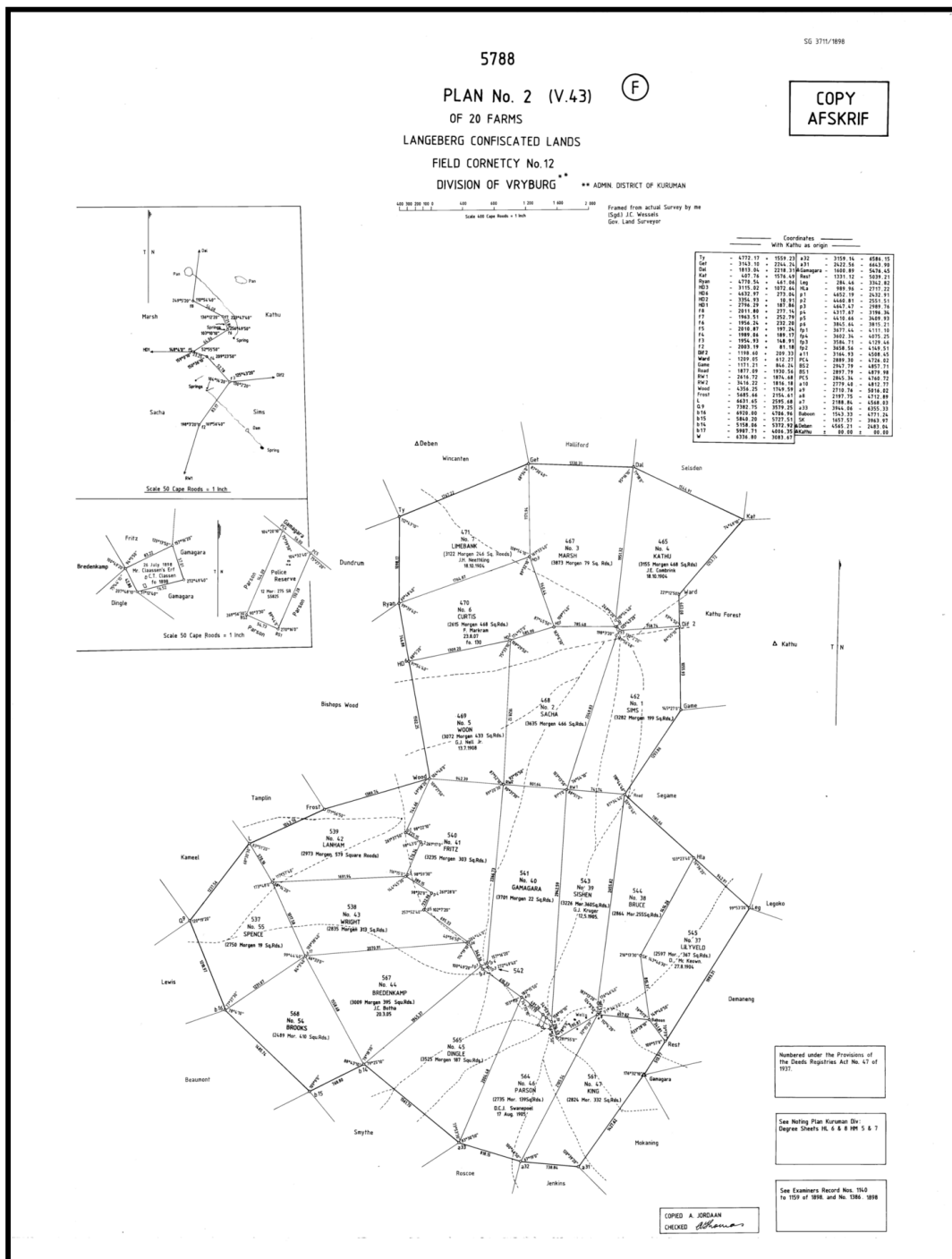

FIG. 6: 1898 MAP OF KING 561

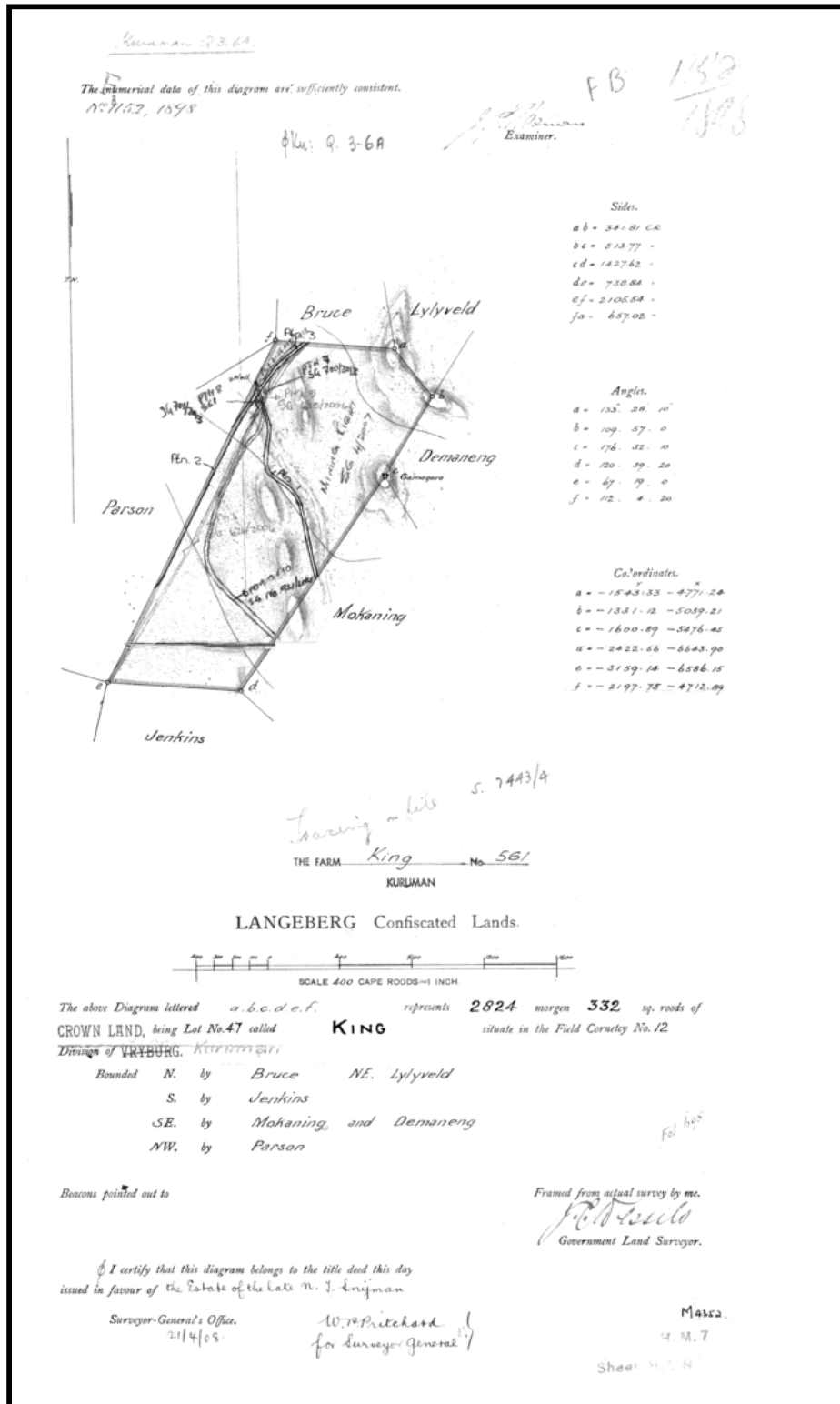
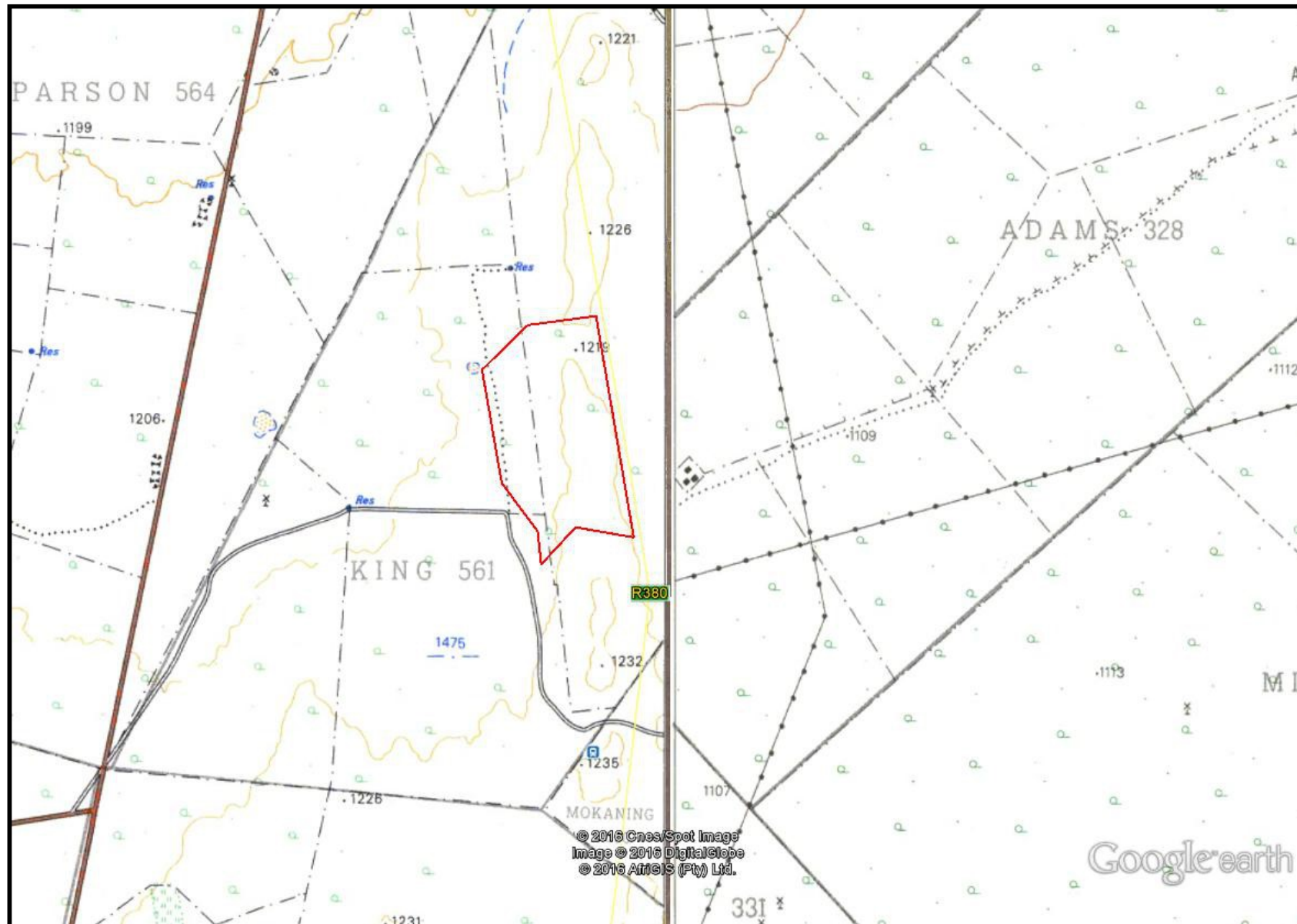

FIG. 7: LOCALITY MAP IN 1974



The 1974 topographical map indicates that there are no structures in the study area (fig. 7).

PALAEONTOLOGICAL IMPACT ASSESSMENT

A palaeontological desktop survey was undertaken by Dr. Gideon Groenewald. (Appendix B). In summary he states:

“The study area is underlain by windblown sand and possibly calcrete of the Quaternary Gordonia Formation. No fossils are expected to be obviously present in the Quaternary sediments and any recording of fossils will be highly significant. The underlying Vaalian aged sediments are known to contain significant examples of Stromatolites, but these structures will only be associated with the tailings of the mining operation and need to be reported to the HIA specialist by the ECO if observed”

Significance: The study area has been allocated a Moderate sensitivity.

Management plan: All sections of the development where trenching for infrastructure will be deeper than 1,5m, need to be inspected and recorded by a professional Palaeontologist. This is in accordance with SAHRA specifications as part of a Phase 1 Palaeontological Impact Assessment.

CONCLUSION

A desktop heritage survey was undertaken for the Mamatwan Manganese Mine. Several HIAs have occurred in the general area, and more specifically on two adjacent plots. The surveys noted the area for having historical significance in terms of annexed lands and the Langeberg Rebellion. In terms of the archaeology, the area is of low significance and is unlikely to yield anything more

than a few stone tools. No further mitigation in terms of archaeology is required. A palaeontological survey will be required if any excavations are deeper than 1.5m

REFERENCES

Archaetnos 2013. A Report On The Heritage Impact Assessment (Aia) For The Proposed Photovoltaic Solar Power Generation Plant On The Farm Adams 328 Near Hotazel In The Northern Cape.

PGS Heritage. 2009. Ntsimbintle Mining (Pty) Ltd On Portions 1, 2, 3 And 8 Of The Farm Mamatwan 331 And The Farm Moab 700 In The Kgalagadi District Municipality Of The Northern Cape Province

Matakoma Heritage Consultants. 2005. Hotazel Manganese Mines Wessels Mine On Section Of The Farms Wessels 227, Dibiaghomo 226 And Dikgathlong 268 Mamatwan Mine On Section Of The Farms Goold 329 And Mamatwan 331 Heritage Assessment

Pistorius, J.C.C. 2008. A Phase I Heritage Impact Assessment (HIA) Study For A Proposed New Power Line For The United Manganese Of Kalahari (UMK) Mine Near Hotazel In The Northern Cape Province Of South Africa

**APPENDIX A
DECLARATION OF SPECIALIST**

QUALIFICATIONS AND EXPERIENCE OF THE AUTHOR

Gavin Anderson has a M. Phil in Archaeology and Social Psychology from the University of Cape Town (1995). He specialised in the last 4000 years of the Western Cape studying social and gender identities of gatherer-hunters and herders, and their interactions. Gavin Anderson ran the Institute for Cultural Resource Management at the Natal Museum from 1995 – 2004. He is a co-director of Umlando from 2004 to the present. Gavin is a member of the Association of Southern African Professional Archaeologists, and the sub-section of the cultural resource management. He is accredited as being a Principle Investigator with expertise in Stone Age, Rock Art and Iron Age archaeology.

DECLARATION OF INDEPENDENCE

I, Gavin Anderson, declare that I am an independent specialist consultant and have no financial, personal or other interest in the proposed development, nor the developers or any of their subsidiaries, apart from fair remuneration for work performed in the delivery of palaeontological heritage assessment services. There are no circumstances that compromise the objectivity of my performing such work.



Gavin Anderson
Archaeologist and heritage Impact Assessor

APPENDIX B
PALAEONTOLOGICAL DESKTOP REPORT

**DESKTOP PALAEOLOGICAL ASSESSMENT
FOR THE PROPOSED TAILINGS DAM FOR
MAMATWAN MINE, SOUTH OF HOTAZEL, JOE
MORELONG LOCAL MUNICIPALITY, JOHN TAOLO
GAETSEWE DISTRICT MUNICIPALITY, NORTHERN
CAPE PROVINCE.**

**FOR
Umlando**

DATE: 07 April 2016

By

**Gideon Groenewald
Cell: 078 713 6377**

EXECUTIVE SUMMARY

Gideon Groenewald was appointed to undertake a desktop survey, assessing the potential palaeontological impact of the proposed new Tailings Dam at the Mamatwan Mine close to the Mamathwane station, south of Hotazel.

The Mamatwan Manganese Mine is situated approximately 21km south of the town of Hotazel. Mining areas include the Remaining Extent of Portion 3, Portion 8, Portion 18 and the Remaining Extent of the Farm Mamatwan No. 331 RD. The mining area falls within the municipal boundaries of the John Taolo Gaetsewe District and Joe Morelong Local Municipality.

This Palaeontological Assessment forms part of the Heritage Impact Assessment (HIA) and complies with the requirements of the South African National Heritage Resource Act No 25 of 1999. In accordance with Section 38 of the National Resources Act No 25 of 1999 (Heritage Resources Management), a HIA is required to assess any potential impacts to palaeontological heritage within the development footprint.

The study area is underlain by windblown sand and possibly calcrete of the Quaternary Gordonia Formation. No fossils are expected to be obviously present in the Quaternary sediments and any recording of fossils will be highly significant. The underlying Vaalian aged sediments are known to contain significant examples of Stromatolites, but these structures will only be associated with the tailings of the mining operation and need to be reported to the HIA specialist by the ECO if observed.

As a result, the study area has been allocated a Moderate sensitivity.

Recommendations:

1. The EAP and ECO of the project must be informed of the fact that significant fossils have been described from the Calcrete that might be present below

the windblown sand on site. The dolomite of the Hotazel Formation that is associated with the manganese ore might also contain very good examples of Stromatolite structures.

2. All sections of the development where trenching for infrastructure will be deeper than 1,5m, the trenches must be inspected and if fossils are recorded, a professional Palaeontologist must be appointed to record and collect the fossils according to SAHRA specifications as part of a Phase 1 Palaeontological Impact Assessment.

TABLE OF CONTENT

INTRODUCTION.....	3
NATIONAL HERITAGE RESOURCES ACT OF 1999.....	7
METHOD.....	9
DESKTOP STUDY.....	13
PALAEONTOLOGICAL IMPACT ASSESSMENT.....	18
CONCLUSION.....	18
REFERENCES.....	19
APPENDIX A.....	20
DECLARATION OF SPECIALIST.....	20
APPENDIX B.....	22
PALAEONTOLOGICAL DESKTOP REPORT.....	22

TABLE OF FIGURES

Figure 1 Talings dam proposed north of Mamathwane Station.....	27
Figure 2 Geology of the study area. The mine area is underlain by windblown sand of the Gordonia Formation.....	32
Figure 3 Palaeosensitivity of the study site. For colour coding see Table 1.....	35

LIST OF TABLES

Table 1 Palaeontological sensitivity analysis outcome classification.....	29
---	----

INTRODUCTION

Gideon Groenewald was appointed to undertake a desktop survey, assessing the potential palaeontological impact of the proposed new Tailings Dam at the Mamatwan Mine close to the Mamathwane station, south of Hotazel (Figure 1).



Figure 1 Tailings dam proposed north of Mamathwane Station

The Mamatwan Manganese Mine is situated approximately 21km south of the town of Hotazel. Mining areas include the Remaining Extent of Portion 3, Portion 8, Portion 18 and the Remaining Extent of the Farm Mamatwan No. 331 RD. The mining area falls within the municipal boundaries of the John Taolo Gaetsewe District and Joe Morelong Local Municipality.

Due to the Mamatwan Mine being located within the water scarce Northern Cape Province, South32 has embarked on a process with the design engineers, Knight Piesold, to design and establish a Slimes Handling and Bulk Water Storage Facility with the objective of optimizing the management of clean and low quality water. It is understood that the facility will make provision for the Slimes

Facility that will allow for waste water from site facilities such as stormwater channels, oil separators and run-off from slimes facilities to be contained and recycled back into the water use of the processing plant. Similarly, the Bulk Water Storage Facility is to receive treated water pumped from the pit, as well as any excess water from the operations for further use on the mine.

SOUTH AFRICAN NATIONAL HERITAGE RESOURCE ACT NO 25/1999

This Palaeontological Assessment forms part of the Heritage Impact Assessment (HIA) and complies with the requirements of the South African National Heritage Resource Act No 25 of 1999. In accordance with Section 38 of the National Resources Act No 25 of 1999 (Heritage Resources Management), a HIA is required to assess any potential impacts to palaeontological heritage within the development footprint.

Categories of heritage resources recognised as part of the National Estate in Section 3 of the Heritage Resources Act, and which therefore fall under its protection, include:

- geological sites of scientific or cultural importance;
- objects recovered from the soil or waters of South Africa, including archaeological and palaeontological objects and material, meteorites and rare geological specimens;
- objects with the potential to yield information that will contribute to an understanding of South Africa's natural or cultural heritage.

METHODOLOGY

Following the "SAHRA APM Guidelines: Minimum Standards for the Archaeological & Palaeontological Components of Impact Assessment Reports" the aims of the palaeontological impact assessment are:

- to identify exposed and subsurface rock formations that are considered to be palaeontologically significant;
- to assess the level of palaeontological significance of these formations;
- to comment on the impact of the development on these exposed and/or potential fossil resources and
- to make recommendations as to how the developer should conserve or mitigate damage to these resources.

In preparing a palaeontological desktop study the potential fossiliferous rock units (groups, formations etc) represented within the study area are determined from geological maps and Google Earth imagery. The known fossil heritage within each rock unit is inventoried from the published scientific literature, previous palaeontological impact studies in the same region and the author's field experience.

The likely impact of the proposed development on local fossil heritage is determined on the basis of the palaeontological sensitivity of the rock units concerned and the nature and scale of the development itself, most notably the extent of bedrock excavation envisaged. The different sensitivity classes used are explained in Table 1 below.

Table 1 Palaeontological sensitivity analysis outcome classification

PALAEONTOLOGICAL SIGNIFICANCE/VULNERABILITY OF ROCK UNITS
The following colour scheme is proposed for the indication of palaeontological sensitivity classes. This classification of sensitivity is adapted from that of Almond et al (2008, 2009) (Groenewald et al.,2014).

RED	<p>Very High Palaeontological sensitivity/vulnerability. Development will most likely have a very significant impact on the Palaeontological Heritage of the region. Very high possibility that significant fossil assemblages will be present in all outcrops of the unit. Appointment of professional palaeontologist, desktop survey, phase I Palaeontological Impact Assessment (PIA) (field survey and recording of fossils) and phase II PIA (rescue of fossils during construction) as well as application for collection and destruction permit compulsory.</p>
ORANGE	<p>High Palaeontological sensitivity/vulnerability. High possibility that significant fossil assemblages will be present in most of the outcrop areas of the unit. Fossils most likely to occur in associated sediments or underlying units, for example in the areas underlain by Transvaal Supergroup dolomite where Cenozoic cave deposits are likely to occur. Appointment of professional palaeontologist, desktop survey and phase I Palaeontological Impact Assessment (field survey and collection of fossils) compulsory. Early application for collection permit recommended. Highly likely that a Phase II PIA will be applicable during the construction phase of projects.</p>
GREEN	<p>Moderate Palaeontological sensitivity/vulnerability. High possibility that fossils will be present in the outcrop areas of the unit or in associated sediments that underlie the unit. For example areas underlain by the Gordonia Formation or undifferentiated soils and alluvium. Fossils described in the literature are visible with the naked eye and development can have a significant impact on the Palaeontological Heritage of the area. Recording of fossils will contribute significantly to the present knowledge of the development of life in the geological record of the region. Appointment of a professional palaeontologist, desktop survey and phase I PIA (ground proofing of desktop survey) recommended.</p>
BLUE	<p>Low Palaeontological sensitivity/vulnerability. Low possibility that fossils that are described in the literature will be visible to the naked eye or be recognized as fossils by untrained persons. Fossils of for example small domal Stromatolites as well as micro-bacteria are associated with these rock units. Fossils of micro-bacteria are extremely important for our understanding of the development of Life, but are only visible under large magnification. Recording of the fossils will contribute significantly to the present knowledge and understanding of the development of Life in the region. Where geological units are allocated a blue colour of significance, and the geological unit is surrounded by highly significant geological units (red or orange coloured units), a palaeontologist must be appointed to do a desktop survey and to make professional recommendations on the impact of development on significant palaeontological finds that might occur in the unit that is allocated a blue colour. An example of this scenario will be where the scale of mapping on the 1:250 000 scale maps excludes small outcrops of highly significant sedimentary rock units occurring in larger alluvium deposits. Collection of a representative sample of potential fossiliferous material is recommended.</p>

GRE Y	<p>Very Low Palaeontological sensitivity/vulnerability. Very low possibility that significant fossils will be present in the bedrock of these geological units. The rock units are associated with intrusive igneous activities and no life would have been possible during emplacement of the rocks. It is however essential to note that the geological units mapped out on the geological maps are invariably overlain by Cenozoic aged sediments that might contain significant fossil assemblages and archaeological material. Examples of significant finds occur in areas underlain by granite, just to the west of Hoedspruit in the Limpopo Province, where significant assemblages of fossils and clay-pot fragments are associated with large termite mounds. Where geological units are allocated a grey colour of significance, and the geological unit is surrounded by very high and highly significant geological units (red or orange coloured units), a palaeontologist must be appointed to do a desktop survey and to make professional recommendations on the impact of development on significant palaeontological finds that might occur in the unit that is allocated a grey colour. An example of this scenario will be where the scale of mapping on the 1:250 000 scale maps excludes small outcrops of highly significant sedimentary rock units occurring in dolerite sill outcrops. It is important that the report should also refer to archaeological reports and possible descriptions of palaeontological finds in Cenozoic aged surface deposits.</p>
------------------	--

When rock units of moderate to high palaeontological sensitivity are present within the development footprint, a field-based assessment by a professional palaeontologist is usually warranted.

The key assumption for this desktop study is that the existing geological maps and datasets used to assess site sensitivity are correct and reliable. However, the geological maps used were not intended for fine scale planning work and are largely based on aerial photographs alone, without ground-truthing.

These factors may have a major influence on the assessment of the fossil heritage significance of a given development and, without supporting field assessments, may lead to either:

- an underestimation of the palaeontological significance of a given study area due to ignorance of significant recorded or unrecorded fossils preserved there, or

- an overestimation of the palaeontological sensitivity of a study area, for example when originally rich fossil assemblages inferred from geological maps have in fact been destroyed by weathering, or are buried beneath a thick mantle of unfossiliferous “drift” (soil, alluvium etc).

GEOLOGY

The study area is underlain by Quaternary-aged rocks of the Gordonia Formation, Kalahari Supergroup (Figure 2).



Figure 2 Geology of the study area. The mine area is underlain by windblown sand of the Gordonia Formation.

Gordonia Formation (Qs)

The Quaternary aged Gordonia Formation consists mainly of windblown sand and is usually underlain by calcrete. In general the Gordonia Formation can be described as extensive sand dune deposits, with extensive outcrops of limestone along the banks of the GaMogara River. The sequence of dune sand, calcareous sand, limestone and red claystone was evident at the old York Mine to the north of the study area. The limestone is interbedded with prominent calcareous conglomerate beds with predominantly clasts of Ongeluk lava and scattered clasts of banded iron stone and Jaspelite.

Pre-Kalahari Formations

Where the Gordonia Formation is removed by mining, the underlying geology exposes rocks of the Manganese enriched Ghaap Group locally known as the Hotazel Formation (Van der Merwe, 1997), the mainly banded ironstone Kuruman Formation with subordinate dolomite and the Danielskuil Formation that is mainly characterized by banded jaspilite (Johnson et al 2006).

PALAEONTOLOGY

Gordonia Formation (Qs)

Historically known as the Kalahari Formation, the Gordonia Formation now forms part of the Kalahari Group. Palynomorphs, root casts (rhizomorphs / rhizoliths) and burrows (eg termitaria), rare vertebrate remains (mammals, fish, ostrich egg shell etc), diatoms, freshwater stromatolites, freshwater and terrestrial shells (gastropods, bivalves), ostracods and charophytes have been recorded from this formation (Groenewald et al, 2014; MacRae, 1999; McCarthy and Rubidge, 2005).

Pre-Kalahari aged Formations

During mining the pre-Kalahari aged rocks, notably the dolomitic rocks will be exposed. Stromatolites are associated with these dolomitic sediments and are an important source of information on the geological history of the area at Hotazel (Van der Merwe, 1997; MacRae, 1999, McCarthy and Rubidge, 2005).

DISCUSSION

The predicted palaeontological impact of the development is based on the initial mapping assessment and literature reviews. No significant fossils have up to date, been recorded from the windblown sand that overlies most of the study

area and it is unlikely that significant fossils will be present in the loose sand on site. Significant fossils have however been recorded from the Hotazel Formation (Ghaap Group) and the recording of Stromatolites fossils and other fossils from this mine will contribute significantly to our understanding of the palaeo-environments that existed during the Vaalian age. It is likely that stromatolitic dolomite will be exposed during excavation. The structures will be observed in the coarser grained tailings from the mine. The ECO must record the presence of Stromatolites and report the finding by informing the HIA specialist.

MANAGEMENT PLAN

The likely impact of the proposed development on local fossil heritage is determined on the basis of the palaeontological sensitivity of the rock units concerned and the nature and scale of the development itself, most notably the extent of unweathered bedrock excavation envisaged. The sensitivity class used is explained in Table 1.

The palaeontological sensitivity of the development is related to the specific geology that underlies the development footprints. For the sake of this desktop survey it is assumed that there will be significant excavation on site, and that trenching of up to 2m depth will in fact expose bedrock of all the geological formations recorded in the desktop survey. Due to the fact that the recording of fossils will have a significant impact on our understanding of the palaeo-environments in this part of the basin, a Moderate Palaeontological sensitivity is allocated to the study area and the ECO must inform the HIA specialist if any significant Stromatolite structures are recorded.

The palaeontological sensitivity of the study area is shown in Figure 3.

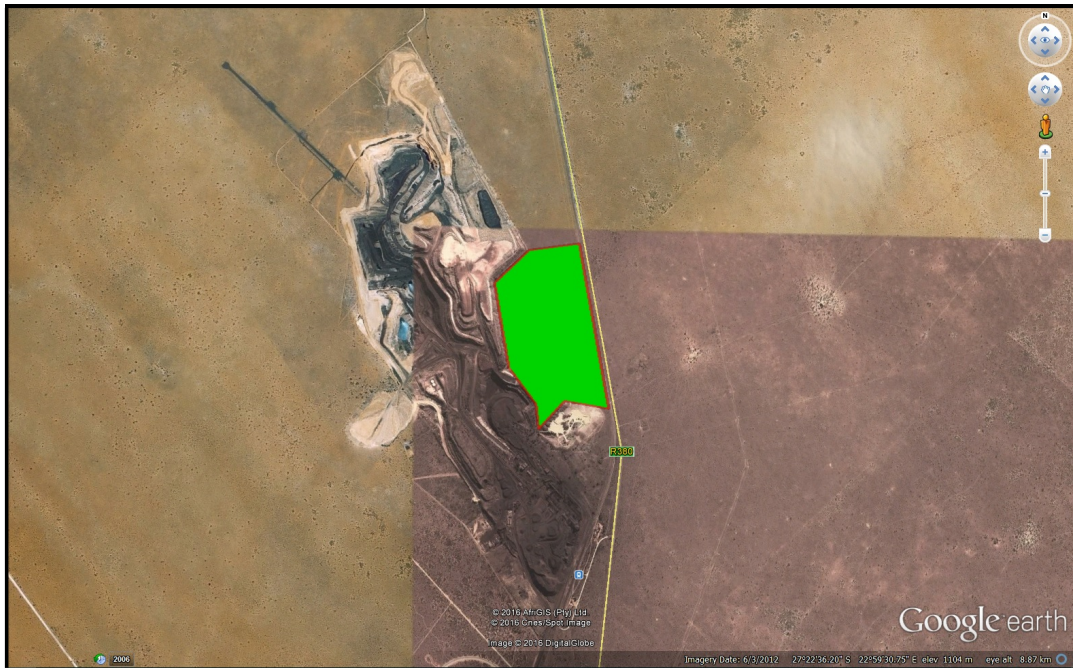

Figure 3 Palaeosensitivity of the study site. For colour coding see Table 1

CONCLUSION AND RECOMMENDATIONS

The study area is underlain by windblown sand and possibly calcrete of the Quaternary Gordonia Formation. No fossils are expected to be obviously present in the Quaternary sediments and any recording of fossils will be highly significant. The underlying Vaalian aged sediments are known to contain significant examples of Stromatolites, but these structures will only be associated with the tailings of the mining operation and need to be reported to the HIA specialist by the ECO if observed.

As a result, the study area has been allocated a Moderate sensitivity.

Recommendations:

3. The EAP and ECO of the project must be informed of the fact that significant fossils have been described from the Calcrete that might be present below the windblown sand on site. The dolomite of the Hotazel Formation that is associated with the manganese ore might also contain very good examples of Stromatolite structures.

4. All sections of the development where trenching for infrastructure will be deeper than 1,5m, the trenches must be inspected and if fossils are recorded, a professional Palaeontologist must be appointed to record and collect the fossils according to SAHRA specifications as part of a Phase 1 Palaeontological Impact Assessment.

REFERENCES

Almond J.E. and Pether J. 2008. *Palaeontological Heritage of the Western Cape.* Internal Report Heritage Western Cape.

Groenewald G.H., Groenewald D.P. and Groenewald S.M., 2014. *Palaeontological Heritage of the Free State, Gauteng, Limpopo, Mpumalanga and North West Provinces.* Internal Palaeotechnical Reports, SAHRA.

Johnson MR , Anhaeusser CR and Thomas RJ (Eds). 2009. *The Geology of South Africa.* GSSA, Council for Geoscience, Pretoria.

MacRae C. 1999. *Life Etched in Stone.* Geological Society of South Africa, Linden, South Africa.

McCarthy T and Rubidge BS. 2005. *Earth and Life.* 333pp. Struik Publishers, Cape Town.

Van der Merwe SJ. 1997. *Basin Analysis of the Kalahari Manganese Basin.* Unpublished MSc Thesis, UOFS.

QUALIFICATIONS AND EXPERIENCE OF THE AUTHOR

Dr Gideon Groenewald has a PhD in Geology from the University of Port Elizabeth (Nelson Mandela Metropolitan University) (1996) and the National Diploma in Nature Conservation from Technicon RSA (the University of South Africa) (1989). He specialises in research on South African Permian and Triassic sedimentology and macrofossils with an interest in biostratigraphy, and palaeo-ecological aspects. He has extensive experience in the locating of fossil material in the Karoo Supergroup and has more than 20 years of experience in locating, collecting and curating fossils, including exploration field trips in search of new localities in the southern, western, eastern and north-eastern parts of the country. His publication record includes multiple articles in internationally recognized journals. Dr Groenewald is accredited by the Palaeontological Society of Southern Africa (society member for 25 years).

DECLARATION OF INDEPENDENCE

I, Gideon Groenewald, declare that I am an independent specialist consultant and have no financial, personal or other interest in the proposed development, nor the developers or any of their subsidiaries, apart from fair remuneration for work performed in the delivery of palaeontological heritage assessment services. There are no circumstances that compromise the objectivity of my performing such work.



Dr Gideon Groenewald
Geologist